

GARRY ROGERS NISSAN



SUBARU[®]

LEGACY

1992
SERVICE
MANUAL
SECTION 1



SUBARU® 1992 SERVICE MANUAL

FOREWORD

This service manual has been prepared to provide SUBARU service personnel with the necessary information and data for the correct maintenance and repair of SUBARU vehicle.

This manual includes the procedures for maintenance, disassembling, reassembling, inspection and adjustment of components and troubleshooting for guidance of both the fully qualified and the less-experienced mechanics. Please peruse and utilize this manual fully to ensure complete repair work for satisfying our customers by keeping their vehicle in optimum condition. When replacement of parts during repair work is needed, be sure to use SUBARU genuine parts.

All information, illustration and specifications contained in this manual are based on the latest product information available at the time of publication approval.

FUJI HEAVY INDUSTRIES LTD.

All right reserved. This book may not be reproduced or copied, in whole or in part, without the written permission of
FUJI HEAVY INDUSTRIES LTD., TOKYO JAPAN.

SUBARU,  and  are trademarks of
FUJI HEAVY INDUSTRIES LTD.

© Copyright 1991 FUJI HEAVY INDUSTRIES LTD.

1 GENERAL SECTION

SPECIFICATIONS

GENERAL INFORMATION

PRE-DELIVERY INSPECTION

PERIODIC MAINTENANCE SERVICES

SPECIAL TOOLS

IMPORTANT SAFETY NOTICE

Providing appropriate service and repair is a matter of great importance in the serviceman's safety maintenance and safe operation, function and performance which the SUBARU vehicle possesses.

In case the replacement of parts or replenishment of consumables is required, genuine SUBARU parts whose parts numbers are designated or their equivalents must be utilized.

It must be made well known that the safety of the serviceman and the safe operation of the vehicle would be jeopardized if he used any service parts, consumables, special tools and work procedure manuals which are not approved or designated by SUBARU.

How to use this manual

- This Service Manual is divided into six volumes by section so that it can be used with ease at work. Refer to the Table of Contents, select and use the necessary section.
- Each chapter in the manual is basically made of the following five types of areas.

M : Mechanism and function

S : Specifications and service data

C : Component parts

W : Service procedure

(X : Service procedure)

(Y : Service procedure)

T : Troubleshooting

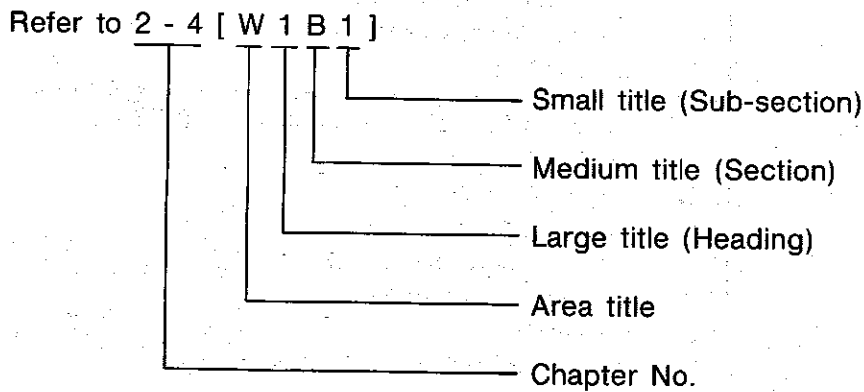
- The description of each area is provided with four types of titles different in size as shown below. The Title No. or Symbol prefixes each title in order that the construction of the article and the flow of explanation can be easily understood.

[Example of each title]

- Area title: W. Service procedure (one of the five types of areas)
- Large title (Heading): 1. Oil Pump (to denote the main item of explanation)
- Medium title (Section): A. REMOVAL (to denote the type of work in principle)
- Small title (Sub-section): 1. INNER ROTATOR (to denote a derivative item of explanation)

The Title Index No. is indicated on the top left (or right) side of the page as the book is opened. This is useful for retrieving the necessary portion.

(Example of usage)



Example of title placement

CLUTCH

2-10 [W 1 A 0]

W SERVICE PROCEDURE

1.General

A: PRECAUTION

When servicing clutch system, pay attention to the following items.

- 1) Check the routing of clutch cable for smoothness.
- 2) Excessive tightness or looseness of clutch cable have a bad influence upon the cable durability.
- 3) Apply grease sufficiently to the connecting portion of clutch pedal.
- 4) Apply grease sufficiently to the release lever portion.
- 5) Position clutch cable through the center of toeboard hole

Adjustment is done by

2.RELEASE LEVER

Check lever pivot portion and the point of contact with holder for wear.

2.Release Bearing and Lever

A: REMOVAL

2) Seal

In this manual, the following symbols are used.

: Should be lubricated with oil.

: Should be lubricated with grease.

: Sealing point

: Tightening torque

TABLE OF CONTENTS

1	GENERAL SECTION	<ul style="list-style-type: none"> 1-1 Specifications 1-2 ★★★★★★★★★★ 1-3 General Information 1-4 Pre-Delivery Inspection 1-5 Periodic Maintenance Services 1-6 Special Tools
2	ENGINE SECTION	<ul style="list-style-type: none"> 2-1 Emission Control System and Vacuum Fitting 2-2 On-Car Services 2-3a Engine (SOHC) 2-3b Engine (DOHC) 2-4 Engine Lubrication System 2-5 Engine Cooling System 2-6 Carburetor 2-7a Fuel Injection System (MPFI Non-TURBO) 2-7b Fuel Injection System (SPFI) 2-7c Fuel Injection System (MPFI TURBO) 2-8 Fuel System 2-9 Exhaust System 2-10 Clutch 2-11 Engine and Transmission Mounting System
3	TRANSMISSION AND DIFFERENTIAL SECTION	<ul style="list-style-type: none"> 3-1 Manual Transmission and Differential 3-2a Automatic Transmission and Differential (4AT) 3-2b ★★★★★★★★★★ 3-3 Transmission Control System 3-4 4WD System
4	MECHANICAL COMPONENTS SECTION	<ul style="list-style-type: none"> 4-1 Suspension 4-2 Wheels and Axles 4-3 Steering System 4-4 Brakes 4-5 Pedal System and Control Cables 4-6 Heater and Ventilator 4-7 ★★★★★★★★★★
5	BODY SECTION	<ul style="list-style-type: none"> 5-1 Body and Exterior 5-2 Doors and Windows 5-3 Seats, Seat Belts, and Interior 5-4 Instrument Panel
6	ELECTRICAL SECTION	<ul style="list-style-type: none"> 6-1 Engine Electrical System 6-2 Body Electrical System 6-3 Wiring Diagram and Trouble-shooting

SUBARU®

1992

**SERVICE
MANUAL**



	Page
S SPECIFICATIONS	2
1. Except Australia	2
2. Australia	10

SPECIFICATIONS

1 Except Australia

4-DOOR SEDAN

ITEM	MODEL	4-DOOR SEDAN						
		1600	1800	1600	1800	2200		
		FWD						
		DL		GL		GX		
		CARB. 5MT	CARB. 5MT	CARB. 5MT	CARB. 5MT	CARB. 4AT	MPFI 5MT	MPFI 4AT

1. DIMENSIONS

Overall length	mm (in)	4,545 (178.9)					
Overall width	mm (in)	1,690 (66.5)					
Overall height (at CW)	mm (in)	1,380 (54.3)			1,400 (55.1)		
Compartment	Length	1,875 (73.8)					
	Width	1,415 (55.7)					
	Height	1,155 (45.5)					
Wheelbase	mm (in)	2,580 (101.6)					
Tread	Front	1,475 (58.1)			1,465 (57.7)		
	Rear	1,465 (57.7)			1,455 (57.3)		
Minimum road clearance (at CW)	mm (in)	160 (6.3)					

2. WEIGHT

Curb weight (C.W.)	Front	kg (lb)	645 (1,420)	645 (1,420) 640 (1,410)*1	670 (1,475)	670 (1,475) 665 (1,465)*1	715 (1,575) 710 (1,565)*1	685 (1,510)	730 (1,610)
	Rear	kg (lb)	480 (1,060)	480 (1,060) 470 (1,040)*1	500 (1,105)	500 (1,105) 490 (1,080)*1	505 (1,115) 495 (1,090)*1	505 (1,115)	510 (1,125)
	Total	kg (lb)	1,125 (2,480)	1,125 (2,480) 1,110 (2,450)*1	1,170 (2,580)	1,170 (2,580) 1,155 (2,545)*1	1,220 (2,690) 1,205 (2,655)*1	1,190 (2,625)	1,240 (2,735)
Maximum permissible weight (M.P.W.)	Front	kg (lb)	950 (2,095)						
	Rear	kg (lb)	950 (2,095)						
	Total	kg (lb)	1,870 (4,125)						

3. ENGINE

Engine type	Horizontally opposed, liquid cooled, 4-cylinder, 4-stroke gasoline engine					
Valve arrangement	Overhead camshaft type					
Bore x Stroke	mm (in)	87.9 x 65.8 (3.461 x 2.591)	87.9 x 75 (3.461 x 2.95)	87.9 x 65.8 (3.461 x 2.591)	87.9 x 75 (3.461 x 2.95)	96.9 x 75 (3.815 x 2.95)
Displacement	cm ³ (cu in)	1,597 (97.45)	1,820 (111.06)	1,597 (97.45)	1,820 (111.06)	2,212 (135.0)
Compression ratio		8.9	9.7	8.9	9.7	9.2
Firing order		1-3-2-4				
Idling speed at N or P position	rpm	900±50	800±50	900±50	800±50	800±100
Maximum output	kW (PS)/rpm	70 (95)/6,400	76 (103)/6,000	70 (95)/6,400	76 (103)/6,000	100 (136)/6,000
Maximum torque	N·m (kg-m, ft-lb)/rpm	123 (12.5, 90)/3,200	145 (14.8, 107)/3,200	123 (12.5, 90)/3,200	145 (14.8, 107)/3,200	189 (19.3, 140)/4,800

4. ELECTRICAL

Ignition timing at idling speed	BTDC	8°±2° (without vacuum)	4°±2° (without vacuum)	8°±2° (without vacuum)	4°±2° (without vacuum)	8°±2° (without vacuum)	23°±10°
Spark plug	Type and manufacturer	NGK: BKR6E NIPPONDENSO: K20PR-U					
Alternator		12 V—70 A					
Battery	Type and capacity (5HR)	For Europe	5MT: 55D23L-MF (12 V—48 Ah) 4AT: 75D23L-MF (12 V—52 Ah)				
		Others	5MT: 34B19L-MF (12 V—27 Ah) 4AT: 46B24L-MF (12 V—36 Ah)				

*1: Except Europe

When any of the following optional parts are installed, add the weight to the curb weight.

Weight of optional parts

kg (lb)

	A.B.S.		Power door lock	Power window	Sunroof	Power steering
	1800 & 2000 MPFI	2200 & 2000 TURBO				
Front	15 (33)	16 (35)	0 (0)	1 (2)	6 (13)	1 (2)
Rear	7 (15)	0 (0)	1 (2)	1 (2)	15 (33)	4 (9)
Total	22 (49)	16 (35)	1 (2)	2 (4)	21 (46)	5 (11)

4-DOOR SEDAN						
1800		2000			2200	
4WD						
GL			TURBO		GX	
CARB. 5MT	CARB. 4AT	MPFI 5MT	MPFI 4AT	MPFI 5MT	MPFI 5MT	MPFI 4AT

4,545 (178.9)						
1,690 (66.5)						
1,390 (54.7)			1,400 (55.1)			
1,875 (73.8)						
1,415 (55.7)						
1,155 (45.5)						
2,580 (101.6)						
1,460 (57.5)			1,465 (57.7)		1,460 (57.5)	
1,455 (57.3)						
165 (6.5)					175 (6.9)	

700 (1,545) 695 (1,530)*1	730 (1,610)	710 (1,565)	740 (1,630)	785 (1,730)	725 (1,600) 715 (1,575)*1	755 (1,665) 745 (1,640)*1
565 (1,245) 555 (1,225)*1	570 (1,255)	565 (1,245)	570 (1,260)	590 (1,300)	580 (1,280) 570 (1,260)*1	585 (1,290) 575 (1,270)*1
1,265 (2,790) 1,250 (2,755)*1	1,300 (2,865)	1,275 (2,810)	1,310 (2,890)	1,375 (3,030)	1,305 (2,880) 1,285 (2,835)*1	1,340 (2,955) 1,320 (2,910)*1
950 (2,095)						
950 (2,095)						
1,870 (4,125)						

Horizontally opposed, liquid cooled, 4-cylinder, 4-stroke gasoline engine			
Overhead camshaft type			
87.9 x 75 (3.461 x 2.95)	92 x 75 (3.62 x 2.95)		96.9 x 75 (3.815 x 2.95)
1,820 (111.06)	1,994 (121.67)		2,212 (135.0)
9.7	9.2	9.5	8.0
1-3-2-4			
800±50	800±100	900±100	800±100
76 (103)/6,000	85 (116)/5,600	147 (200)/6,000	100 (136)/6,000
145 (14.8, 107)/3,200	164 (16.7, 121)/4,400	260 (26.5, 192)/3,600	189 (19.3, 140)/4,800

4°±2° (without vacuum)	8°±2° (without vacuum)	23°±10°	18°±10°	23°±10°
NGK: BKR6E NIPPONDENSO: K20PR-U	NGK: BKR6E-11 NIPPONDENSO: K20PR-U11	NGK: BKR6EVX PFR6B PFR6G	NGK: BKR6E, [BKR6E-11]*2 NIPPONDENSO: K20PR-U, [K20PR-U11]*2	
12 V—70 A				
5MT: 55D23L-MF (12 V—48 Ah) 4AT: 75D23L-MF (12 V—52 Ah)				
5MT: 34B19L-MF (12 V—27 Ah) 4AT: 46B24L-MF (12 V—36 Ah)				

*1: Except Europe

*2: Catalyst equipped vehicles

ITEM	MODEL	4-DOOR SEDAN						
		1600		1800		2200		
		FWD						
		DL		GL		GX		
		CARB. 5MT	CARB. 5MT	CARB. 5MT	CARB. 5MT	CARB. 4AT	MPFI 5MT	MPFI 4AT

5. TRANSMISSION

Clutch type		DSPD	DSPD	DSPD	DSPD	TC	DSPD	TC	
Transmission type		*3	*3	*3	*3	*4	*3	*4	
Gear ratio	1st	3.636	3.636	3.636	3.636	2.785	3.545	2.785	
	2nd	2.105	2.105	2.105	2.105	1.483	2.111	1.483	
	3rd	1.428	1.428	1.428	1.428	1.000	1.448	1.000	
	4th	1.093	1.093	1.093	1.093	0.729	1.088	0.729	
	5th	0.885	0.885	0.885	0.885	—	0.871	—	
	Reverse	3.583	3.583	3.583	3.583	2.696	3.416	2.696	
Auxiliary transmission gear ratio		High	—	—	—	—	—	—	
		Low	—	—	—	—	—	—	
Reduction gear (Front drive)	1st reduction	Type of gear	—	—	—	Helical	—	Helical	
		Gear ratio	—	—	—	1.000	—	1.000	
	Final reduction	Type of gear	Hypoid						
		Gear ratio	4.111	3.900	4.111	3.900	4.444	3.700	4.111
Reduction gear (Rear drive)	Transfer reduction	Type of gear	—	—	—	—	—	—	
		Gear ratio	—	—	—	—	—	—	
	Final reduction	Type of gear	—	—	—	—	—	—	
		Gear ratio	—	—	—	—	—	—	

6. STEERING

Type	Rack and pinion
Turns, lock to lock	Manual steering: 4.5, Power steering: 3.3
Minimum turning circle m (ft)	Wall to wall: 11.0 (36.1)/Curb to curb: 10.2 (33.5)

7. SUSPENSION

Front	Macpherson strut type, Independent, Coil spring
Rear	Dual link strut type, Independent, Coil spring

8. BRAKE

Service brake system	Dual circuit hydraulic with vacuum suspended power unit	
Front	Ventilated disc brake	
Rear	Drum brake (Leading and trailing type)*5	Disc brake
Parking brake	Mechanical on rear brakes	

9. TIRE

Size	165R13 82T	165R13 82T 165R13 82H	175/70R14 84S	165R13 82T 165R13 82H	185/70R14 87H 185/70R14 88H
Type	Steel belted radial, Tubeless				

10. CAPACITY

Fuel tank	ℓ (US gal, Imp gal)	60 (15.9, 13.2)						
Engine oil	Upper level ℓ (US qt, Imp qt)	4.5 (4.8, 4.0)						
	Lower level ℓ (US qt, Imp qt)	3.5 (3.7, 3.1)						
Transmission gear oil	ℓ (US qt, Imp qt)	2.6 (2.7, 2.3)	2.6 (2.7, 2.3)	2.6 (2.7, 2.3)	2.6 (2.7, 2.3)	—	3.3 (3.5, 2.9)	—
Automatic transmission fluid	ℓ (US qt, Imp qt)	—	—	—	—	8.3 (8.8, 7.3)	—	8.3 (8.8, 7.3)
AT differential gear oil	ℓ (US qt, Imp qt)	—	—	—	—	1.2 (1.3, 1.1)	—	1.2 (1.3, 1.1)
4WD rear differential gear oil	ℓ (US qt, Imp qt)	—						
Power steering fluid	ℓ (US qt, Imp qt)	0.7 (0.7, 0.6)						
Engine coolant	ℓ (US qt, Imp qt)	Approx. MT: 6.3 (6.7, 5.5) AT: 6.2 (6.6, 5.5)				Approx. MT: 5.9 (6.2, 5.2) AT: 5.8 (6.1, 5.1)		

DSPD: Dry Single Plate Diaphragm

TC: Torque Converter

*3: 5-forward speeds with synchromesh and 1-reverse speed

*4: Electronically controlled fully-automatic, 4-forward speeds and 1-reverse speed

*5: When optional ABS is equipped, rear brake shall be a disc brake.

SPECIFICATIONS

[S1A10] 1-1

4-DOOR SEDAN						
1800		2000			2200	
4WD						
GL				TURBO	GX	
CARB. 5MT	CARB. 4AT	MPFI 5MT	MPFI 4AT	MPFI 5MT	MPFI 5MT	MPFI 4AT

DSPD	TC	DSPD	TC	DSPD	DSPD	TC
*6	*4	*6	*4	*6	*6	*4
3.545	2.785	3.545	2.785	3.545	3.545	2.785
2.111	1.483	2.111	1.483	1.947	2.111	1.483
1.448	1.000	1.448	1.000	1.366	1.448	1.000
1.088	0.729	1.088	0.729	0.972	1.088	0.729
0.871	—	0.871	—	0.780	0.871	—
3.416	2.696	3.416	2.696	3.416	3.416	2.696
—	—	—	—	—	—	—
—	—	—	—	—	—	—
—	Helical	—	Helical	—	—	Helical
—	1.000	—	1.000	—	—	1.000
Hypoid						
4.111	4.444	4.111	4.444	3.900	3.900	4.111
Helical	—	Helical	—	Helical	Helical	—
1.000	—	1.000	—	1.100	1.000	—
Hypoid						
4.111	4.444	4.111	4.444	3.545	3.900	4.111

Rack and pinion
Manual steering: 4.5, Power steering: 3.3, 3.0 ... [TURBO]
Wall to wall: 11.0 (36.1)/Curb to curb: 10.1 (33.1), 10.6 (34.8) ... [TURBO]

Macpherson strut type, Independent, Coil spring
Dual link strut type, Independent, Coil spring

Dual circuit hydraulic with vacuum suspended power unit		
Ventilated disc brake		
Drum brake (Leading and trailing type)*5	Ventilated disc brake	Disc brake
Mechanical on rear brakes		

175/70R14 84T 175/70R14 84H	175/70R14 84T	205/60R15 91V	185/70R14 87H 185/70R14 88H
Steel belted radial, Tubeless			

60 (15.9, 13.2)						
4.5 (4.8, 4.0)						
3.5 (3.7, 3.1)						
3.5 (3.7, 3.1)	—	3.5 (3.7, 3.1)	—	3.5 (3.7, 3.1)	3.5 (3.7, 3.1)	—
—	8.3 (8.8, 7.3)	—	8.3 (8.8, 7.3)	—	—	8.3 (8.8, 7.3)
—	1.2 (1.3, 1.1)	—	1.2 (1.3, 1.1)	—	—	1.2 (1.3, 1.1)
0.8 (0.8, 0.7)						
0.7 (0.7, 0.6)						
Approx. MT: 6.3 (6.7, 5.5) AT: 6.2 (6.6, 5.5)		Approx. MT: 6.1 (6.4, 5.4) AT: 6.0 (6.3, 5.3)		Approx. 7.2 (7.6, 6.3)	Approx. MT: 5.9 (6.2, 5.2) AT: 5.8 (6.1, 5.1)	

*6: 5-forward speeds with synchromesh and 1-reverse speed — with center differential and viscous coupling

B: STATION WAGON AND TOURING WAGON

ITEM	MODEL	STATION WAGON						
		1600		1800		1800		
		FWD						4WD
		DL			GL			DL
		CARB. 5MT	CARB. 5MT	CARB. 5MT	CARB. 5MT	CARB. 4AT	SPFI 5MT	

1. DIMENSIONS

Overall length	mm (in)	4,620 (181.9)					
Overall width	mm (in)	1,690 (66.5)					
Overall height (at CW)	mm (in)	1,420 (55.9)					
Compartment	Length	mm (in)	1,820 (71.7)				
	Width	mm (in)	1,415 (55.7)				
	Height	mm (in)	1,165 (45.9)				
Wheelbase	mm (in)	2,585 (101.8)					
Tread	Front	mm (in)	1,475 (58.1)		1,465 (57.7)		1,460 (57.5)
	Rear	mm (in)	1,460 (57.5)		1,450 (57.1)		1,450 (57.1)
Minimum road clearance (at CW)	mm (in)	160 (6.3)					

2. WEIGHT

Curb weight (C.W.)	Front	kg (lb)	630 (1,390)	625 (1,380)	655 (1,445)	655 (1,445) 650 (1,430)*1	695 (1,530)	675 (1,490)
	Rear	kg (lb)	550 (1,210)	540 (1,190)	565 (1,245)	565 (1,245) 555 (1,225)*1	560 (1,235)	615 (1,355)
	Total	kg (lb)	1,180 (2,600)	1,165 (2,570)	1,220 (2,690)	1,220 (2,690) 1,205 (2,655)*1	1,255 (2,765)	1,290 (2,845)
Maximum permissible weight (M.P.W.)	Front	kg (lb)	950 (2,095)					950 (2,095)
	Rear	kg (lb)	950 (2,095)					1,000 (2,205)
	Total	kg (lb)	1,900 (4,190)					1,950 (4,300)

3. ENGINE

Engine type	Horizontally opposed, liquid cooled, 4-cylinder, 4-stroke gasoline engine						
Valve arrangement	Overhead camshaft type						
Bore x Stroke	mm (in)	87.9 x 65.8 (3.461 x 2.591)	87.9 x 75 (3.461 x 2.95)	87.9 x 65.8 (3.461 x 2.591)	87.9 x 75 (3.461 x 2.95)		
Displacement	cm ³ (cu in)	1,597 (97.45)	1,820 (111.06)	1,597 (97.45)	1,820 (111.06)		
Compression ratio		8.9	9.7	8.9	9.7	9.2	9.7
Firing order	1-3-2-4						
Idling speed at N or P position	rpm	900±50	800±50	900±50	800±50		850±100
Maximum output	kW (PS)/rpm	70 (95)/6,400	76 (103)/6,000	70 (95)/6,400	76 (103)/6,000		
Maximum torque	N·m (kg-m, ft-lb)/rpm	123 (12.5, 90)/ 3,200	145 (14.8, 107)/ 3,200	123 (12.5, 90)/ 3,200	145 (14.8, 107)/3,200		147 (15.0, 108)/3,200

4. ELECTRICAL

Ignition timing at idling speed	BTDC	8°±2° (without vacuum)	4°±2° (without vacuum)	8°±2° (without vacuum)	4°±2° (without vacuum)	8°±2° (without vacuum)	20°±10°
Spark plug	Type and manufacturer	NGK: BKR6E NIPPONDENSO: K20PR-U					NGK: BKR6E-11 NIPPONDENSO: K20PR-U11
Alternator	12 V—70 A						
Battery	Type and capacity (5HR)	For Europe	5MT: 55D23L-MF (12 V—48 Ah) 4AT: 75D23L-MF (12 V—52 Ah)				
		Others	5MT: 34B19L-MF (12 V—27 Ah) 4AT: 46B24L-MF (12 V—36 Ah)				

*1: Except Europe

When any of the following optional parts are installed, add the weight to the curb weight.

Weight of optional parts

kg (lb)

	A.B.S.		Power door lock	Power window	Air conditioner	Sunroof		Power steering	Roof rail
	1800 & 2000 MPFI	2200 & 2000 TURBO				Station wagon	Touring wagon		
Front	15 (33)	16 (35)	0 (0)	1 (2)	26 (57)	6 (13)	5 (11)	7 (15)	1 (2)
Rear	7 (15)	0 (0)	1 (2)	1 (2)	-2 (-4)	15 (33)	16 (35)	-1 (-2)	4 (9)
Total	22 (49)	16 (35)	1 (2)	2 (4)	24 (53)	21 (46)	21 (46)	6 (13)	5 (11)

STATION WAGON		TOURING WAGON								
1800	2000	1800		2000				2200		
DL		GL				TURBO		GX		
CARB. 5MT	MPFI 5MT	CARB. 5MT	CARB. 4AT	MPFI 5MT	MPFI 4AT	MPFI 5MT	MPFI 5MT	MPFI 5MT*7	MPFI 4AT	
4,620 (181.9)										
1,690 (66.5)										
1,430 (56.3)		1,480 (58.3)				1,470 (57.9)		1,480 (58.3)		1,470 (57.9)
1,820 (71.7)										
1,415 (55.7)										
1,165 (45.5)		1,205 (47.4)								
2,580 (101.6)										
1,460 (57.5)				1,465 (57.7)		1,460 (57.5)				
1,450 (57.1)				1,455 (57.3)		1,450 (57.1)		1,455 (57.3)		
165 (6.5)		175 (6.9)				165 (6.5)		175 (6.9)		

665 (1,465)	680 (1,500)	695 (1,535) 690 (1,520)*1	720 (1,590) 715 (1,575)*1	705 (1,555)	730 (1,610)	770 (1,700)	710 (1,565) 700 (1,545)*1	715 (1,575)	745 (1,640) 735 (1,620)*1
605 (1,335)	615 (1,355)	640 (1,410) 630 (1,390)*1	645 (1,420) 635 (1,400)*1	640 (1,410)	645 (1,420)	660 (1,455)	655 (1,445) 645 (1,420)*1	655 (1,445)	655 (1,445) 645 (1,425)*1
1,270 (2,800)	1,295 (2,855)	1,335 (2,945) 1,320 (2,910)*1	1,365 (3,010) 1,350 (2,975)*1	1,345 (2,965)	1,375 (3,030)	1,430 (3,155)	1,365 (3,010) 1,345 (2,965)*1	1,370 (3,020)	1,400 (3,085) 1,380 (3,045)*1
950 (2,095)		950 (2,095)							
1,000 (2,205)		1,030 (2,270)							
1,950 (4,300)		1,950 (4,300)							

Horizontally opposed, liquid cooled, 4-cylinder, 4-stroke gasoline engine					
Overhead camshaft type					
87.9 x 75 (3.461 x 2.95)	92 x 75 (3.62 x 2.95)	87.9 x 75 (3.461 x 2.95)		92 x 75 (3.62 x 2.95)	
1,820 (111.06)	1,994 (121.67)	1,820 (111.06)		1,994 (121.67)	
9.7	9.5	9.7	9.2	9.5	8.0
1-3-2-4					
800±50	800±100	800±50		800±100	900±100
76 (103)/6,000	85 (116)/5,600	76 (103)/6,000		85 (116)/5,600	147 (200)/6,000
145 (14.8, 107)/3,200	164 (16.7, 121)/4,400	145 (14.8, 107)/3,200		164 (16.7, 121)/4,400	260 (26.5, 192)/3,600
800±100					
100 (136)/6,000					
189 (19.3, 140)/4,800					

4°±2° (with-out vacuum)	8°±2° (with-out vacuum)	4°±2° (with-out vacuum)	8°±2° (with-out vacuum)	23°±10°	18°±10°	23°±10°
NGK: BKR6E NIPPON-DENSO: K20PR-U	NGK: BKR6E-11 NIPPON-DENSO: K20PR-U11	NGK: BKR6E NIPPONDENSO: K20PR-U		NGK: BKR6E-11 NIPPONDENSO: K20PR-U11	NGK: BKR6EVX PFR6B PFR6G	NGK: BKR6E, [BKR6E-11]*2 NIPPONDENSO: K20PR-U, [K20PR-U11]*2
12 V—70 A						
5MT: 55D23L-MF (12 V—48 Ah) 4AT: 75D23L-MF (12 V—52 Ah)						
5MT: 34B19L-MF (12 V—27 Ah) 4AT: 46B24L-MF (12 V—36 Ah)						

*1: Except Europe

*2: Catalyst equipped vehicles

*7: Pneumatic suspension equipped vehicles

ITEM	MODEL	STATION WAGON						
		1600		1800		1800		
		FWD						4WD
		DL			GL			DL
		CARB. 5MT	CARB. 5MT	CARB. 5MT	CARB. 5MT	CARB. 4AT	SPFI 5MT	

5. TRANSMISSION

Clutch type		DSPD				TC	DSPD	
Transmission type		*3				*4	*8	
Gear ratio	1st	3.636				2.785	3.545	
	2nd	2.105				1.438	2.111	
	3rd	1.428				1.000	1.448	
	4th	1.093				0.729	1.088	
	5th	0.885				—	0.871	
	Reverse	3.538				2.696	3.538	
Auxiliary transmission gear ratio		High				—	1.000	
		Low				—	1.592	
Reduction gear (Front drive)	1st reduction	Type of gear	—				Helical	—
		Gear ratio	—				1.000	—
	Final reduction	Type of gear	Hypoid				—	—
		Gear ratio	4.111	3.900	4.111	3.900	4.444	4.111
Reduction gear (Rear drive)	Transfer reduction	Type of gear	—				—	Helical
		Gear ratio	—				—	1.000
	Final reduction	Type of gear	—				—	Hypoid
		Gear ratio	—				—	4.111

6. STEERING

Type	Rack and pinion	
Turns, lock to lock	Manual steering: 4.5, Power steering: 3.3	
Minimum turning circle	m (ft) Wall to wall: 11.0 (36.1)/Curb to curb: 10.2 (33.5) ... FWD, Curb to curb: 10.1 (33.1) ... 4WD	

7. SUSPENSION

Front	Macpherson strut type, Independent, Coil spring
Rear	Dual link strut type, Independent, Coil spring

8. BRAKE

Service brake system	Dual circuit hydraulic with vacuum suspended power unit
Front	Ventilated disc brake
Rear	Drum brake (Leading and trailing type)*5
Parking brake	Mechanical on rear brakes

9. TIRE

Size	165R13 82T	175/70R14 84S	175/70R14 84S 175/70R14 84T
Type	Steel belted radial, Tubeless		

10. CAPACITY

Fuel tank	ℓ (US gal, Imp gal)	60 (15.9, 13.2)	
Engine oil	Upper level	ℓ (US qt, Imp qt) 4.5 (4.8, 4.0)	
	Lower level	ℓ (US qt, Imp qt) 3.5 (3.7, 3.1)	
Transmission gear oil	ℓ (US qt, Imp qt)	2.6 (2.7, 2.3)	3.3 (3.5, 2.9)
Automatic transmission fluid	ℓ (US qt, Imp qt)	—	8.3 (8.8, 7.3)
AT differential gear oil	ℓ (US qt, Imp qt)	—	1.2 (1.3, 1.1)
4WD rear differential gear oil	ℓ (US qt, Imp qt)	—	0.8 (0.8, 0.7)
Power steering fluid	ℓ (US qt, Imp qt)	0.7 (0.7, 0.6)	
Engine coolant	ℓ (US qt, Imp qt)	Approx. MT: 6.3 (6.7, 5.5) AT: 6.2 (6.6, 5.5)	

DSPD: Dry Single Plate Diaphragm

TC: Torque Converter

*3: 5-forward speeds with synchromesh and 1-reverse speed

*4: Electronically controlled fully-automatic, 4-forward speeds and 1-reverse speed

*5: When optional ABS is equipped, rear brake shall be a disc brake.

*8: 5x2-forward speeds with synchromesh and 1-reverse speed — with selective 4WD system

SPECIFICATIONS

[S1B10] 1-1

STATION WAGON		TOURING WAGON							
1800	2000	1800			2000			2200	
4WD									
DL		GL				TURBO		GX	
CARB. 5MT	MPFI 5MT	CARB. 5MT	CARB. 4AT	MPFI 5MT	MPFI 4AT	MPFI 5MT	MPFI 5MT	MPFI 5MT*7	MPFI 4AT

DSPD *8	DSPD *8	DSPD *9	TC *4	DSPD *9	TC *4	DSPD *6	DSPD *9	TC *4
3.545	3.545	3.545	2.785	3.545	2.785	3.545	3.545	2.785
2.111	2.111	2.111	1.438	2.111	1.483	1.947	2.111	1.483
1.448	1.448	1.448	1.000	1.448	1.000	1.366	1.448	1.000
1.088	1.088	1.088	0.729	1.088	0.729	0.972	1.088	0.729
0.871	0.871	0.871	—	0.871	—	0.780	0.871	—
3.416	3.416	3.416	2.696	3.416	2.696	3.416	3.416	2.696
1.000	1.000	1.000	—	1.000	—	—	1.000	—
1.592	1.196	1.592	—	1.196	—	—	1.196	—
—	—	—	Helical	—	Helical	—	—	Helical
—	—	—	1.000	—	1.000	—	—	1.000

Hypoid								
4.111	4.111	4.111	4.444	4.111	4.444	3.900	3.900	4.111
Helical	Helical	Helical	—	Helical	—	Helical	Helical	—
1.000	1.000	1.000	—	1.000	—	1.100	1.000	—
Hypoid								
4.111	4.111	4.111	4.444	4.111	4.444	3.545	3.900	4.111

Rack and pinion
 Manual steering: 4.5, Power steering: 3.3, 3.2 ... [TURBO]
 Wall to wall: 10.2 (33.5)/Curb to curb: 10.1 (33.1), 10.6 (34.8) ... [TURBO]

Macpherson strut type, Independent, Coil spring	*10
Dual link strut type, Independent, Coil spring	*11

Dual circuit hydraulic with vacuum suspended power unit		
Ventilated disc brake		
Drum brake (Leading and trailing type)*5	Ventilated disc brake	Disc brake
Mechanical on rear brakes		

175/70R14 84S 175/70R14 84T	175/70R14 84T	185/70R14 87H 185/70R14 88H	205/60R15 91V	185/70R14 87H 185/70R14 88H
Steel belted radial, Tubeless				

60 (15.9, 13.2)								
4.5 (4.8, 4.0)								
3.5 (3.7, 3.1)								
3.3 (3.5, 2.9)	3.3 (3.5, 2.9)	3.5 (3.7, 3.1)	—	3.5 (3.7, 3.1)	—	3.5 (3.7, 3.1)	3.5 (3.7, 3.1)	—
—	—	—	8.3 (8.8, 7.3)	—	8.3 (8.8, 7.3)	—	—	8.3 (8.8, 7.3)
—	—	—	1.2 (1.3, 1.1)	—	1.2 (1.3, 1.1)	—	—	1.2 (1.3, 1.1)
0.8 (0.8, 0.7)								
0.7 (0.7, 0.6)								
Approx. 6.3 (6.7, 5.5)	Approx. 6.1 (6.4, 5.4)	Approx. MT: 6.3 (6.7, 5.5) AT: 6.2 (6.6, 5.5)	Approx. MT: 6.1 (6.4, 5.4) AT: 6.0 (6.3, 5.3)	Approx. 7.2 (7.6, 6.3)	Approx. MT: 5.9 (6.2, 5.2) AT: 5.8 (6.1, 5.1)			

- *6: 5-forward speeds with synchromesh and 1-reverse speed — with center differential and viscous coupling
- *7: Pneumatic suspension equipped vehicle
- *9: 5x2-forward speeds with synchromesh and 1-reverse speed — with center differential and viscous coupling
- *10: Macpherson strut type, Independent, Pneumatic suspension with height control
- *11: Dual link strut type, Independent, Pneumatic suspension with height control

2. Australia

A: 4-DOOR SEDAN AND TOURING WAGON

ITEM	MODEL	4-DOOR SEDAN			
		2200			
		FWD			
		LX		GX	
		MPFI 5MT	MPFI 4AT	MPFI 5MT	MPFI 4AT

1. DIMENSIONS

Overall length	mm (in)	4,545 (178.9)	
Overall width	mm (in)	1,690 (66.5)	
Overall height (at CW)	mm (in)	1,400 (55.1)	
Compartment	Length	mm (in)	1,875 (73.8)
	Width	mm (in)	1,415 (55.7)
	Height	mm (in)	1,150 (45.3)
Wheelbase	mm (in)	2,580 (101.6)	
Tread	Front	mm (in)	1,465 (57.7)
	Rear	mm (in)	1,455 (57.3)
Minimum road clearance (at CW)	mm (in)	170 (6.7)	

2. WEIGHT

Curb weight (C.W.)	Front	kg (lb)	680 (1,500)	715 (1,575)	685 (1,510)	720 (1,590)
	Rear	kg (lb)	505 (1,115)	515 (1,135)	510 (1,125)	520 (1,145)
	Total	kg (lb)	1,185 (2,615)	1,230 (2,710)	1,195 (2,635)	1,240 (2,735)
Gross vehicle weight (G.V.W.)	Front	kg (lb)	935 (2,060)			
	Rear	kg (lb)	845 (1,865)			
	Total	kg (lb)	1,780 (3,925)			

3. ENGINE

Engine type	Horizontally opposed, liquid cooled, 4-cylinder, 4-stroke gasoline engine	
Valve arrangement	Overhead camshaft type	
Bore x Stroke	mm (in)	96.9 x 75 (3.815 x 2.95)
Displacement	cm ³ (cu in)	2,212 (135.0)
Compression ratio		9.5
Firing order		1-3-2-4
Idling speed at N or P position	rpm	800 ± 100
Maximum output	kW (PS)/rpm	100 (136)/6,000
Maximum torque	N·m (kg-m, ft-lb)/rpm	189 (19.3, 140)/4,800

4. ELECTRICAL

Ignition timing at idling speed	BTDC	23° ± 10°
Spark plug	Type and manufacturer	NGK: BKR6E-11 NIPPONDENSO: K20PR-U11
Alternator		12 V—70 A
Battery	Type and capacity (5HR)	5MT: 34B19L-MF (12 V—27 Ah) 4AT: 46B24L-MF (12 V—36 Ah)

When any of the following optional parts are installed, add the weight to the curb weight.

Weight of optional parts

kg (lb)

	Power door lock & power window	Power door lock & power window & cruise control	Sunroof		Leather seats	Front fog light
			4-DOOR SEDAN	TOURING WAGON		
Front	1 (2)	3 (7)	6 (13)	5 (11)	2 (4)	2 (4)
Rear	2 (4)	2 (4)	15 (33)	16 (35)	5 (11)	0 (0)
Total	3 (7)	5 (11)	21 (46)	21 (46)	7 (15)	2 (4)

4-DOOR SEDAN			TOURING WAGON			
2000	2200		2200			
4WD			FWD		4WD	
TURBO	GX		GX		GX	
MPFI 5MT	MPFI 5MT	MPFI 4AT	MPFI 5MT	MPFI 4AT	MPFI 5MT	MPFI 4AT

4,545 (178.9)			1,690 (66.5)			
1,400 (55.1)			1,480 (58.3)		1,470 (57.9)	
1,150 (45.3)			1,415 (55.7)		1,205 (47.4)	
			2,580 (101.6)			
1,465 (57.7)		1,460 (57.5)	1,465 (57.7)		1,460 (57.5)	
1,455 (57.3)			1,450 (57.1)		1,455 (57.3)	
165 (6.5)		175 (6.9)	180 (7.1)		175 (6.9)	

770 (1,700)	705 (1,550)	740 (1,630)	675 (1,490)	710 (1,565)	700 (1,545)	735 (1,620)
585 (1,290)	575 (1,270)	580 (1,280)	575 (1,265)	585 (1,290)	640 (1,410)	645 (1,425)
1,355 (2,990)	1,280 (2,820)	1,320 (2,910)	1,250 (2,755)	1,295 (2,855)	1,340 (2,955)	1,380 (3,045)
950 (2,095)			915 (2,020)		935 (2,065)	
915 (2,015)			960 (2,115)		1,030 (2,270)	
1,865 (4,110)			1,875 (4,135)		1,965 (4,335)	

Horizontally opposed, liquid cooled, 4-cylinder, 4-stroke gasoline engine	
Overhead camshaft type	
92 x 75 (3.62 x 2.95)	96.9 x 75 (3.815 x 2.95)
1,994 (121.67)	2,212 (135.0)
8.0	9.5
1-3-2-4	
900±100	800±100
147 (200)/6,000	100 (136)/6,000
260 (26.5, 192)/3,600	189 (19.3, 140)/4,800

18°±10°	23°±10°
NGK: BKR6EVX PFR6B PFR6G	NGK: BKR6E-11 NIPPONDENSO: K20PR-U11
12 V—70 A	
5MT: 34B19L-MF (12 V—27 Ah) 4AT: 46B24L-MF (12 V—36 Ah)	

ITEM	MODEL	4-DOOR SEDAN			
		2200			
		FWD			
		LX		GX	
		MPFI 5MT	MPFI 4AT	MPFI 5MT	MPFI 4AT

5. TRANSMISSION

Clutch type		DSPD	TC	DSPD	TC
Transmission type		*3	*4	*3	*4
Gear ratio	1st	3.545	2.785	3.545	2.785
	2nd	2.111	1.483	2.111	1.483
	3rd	1.448	1.000	1.448	1.000
	4th	1.088	0.729	1.088	0.729
	5th	0.871	—	0.871	—
	Reverse	3.416	2.696	3.416	2.696
Auxiliary transmission gear ratio		High	—	—	—
		Low	—	—	—
Reduction gear (Front drive)	1st reduction	Type of gear	—	Helical	—
		Gear ratio	—	1.000	—
	Final reduction	Type of gear	Hypoid		
		Gear ratio	3.700	4.111	3.700
Reduction gear (Rear drive)	Transfer reduction	Type of gear	—		
		Gear ratio	—		
	Final reduction	Type of gear	—		
		Gear ratio	—		

6. STEERING

Type	Rack and pinion	
Turns, lock to lock	3.3	
Minimum turning circle	m (ft)	Wall to wall: 11.0 (36.1)/Curb to curb: 10.2 (33.5)

7. SUSPENSION

Front	Macpherson strut type, Independent, Coil spring	
Rear	Dual link strut type, Independent, Coil spring	

8. BRAKE

Service brake system	Dual circuit hydraulic with vacuum suspended power unit	
Front	Ventilated disc brake	
Rear	Disc brake	
Parking brake	Mechanical on rear brakes	

9. TIRE

Size	185/70R14 87H 185/70R14 88H	
Type	Steel belted radial, Tubeless	

10. CAPACITY

Fuel tank	ℓ (US gal, Imp gal)	60 (15.9, 13.2)		
Engine oil	Upper level	ℓ (US qt, Imp qt) 4.5 (4.8, 4.0)		
	Lower level	ℓ (US qt, Imp qt) 3.5 (3.7, 3.1)		
Transmission gear oil	ℓ (US qt, Imp qt)	3.3 (3.5, 2.9)	—	3.3 (3.5, 2.9)
Automatic transmission fluid	ℓ (US qt, Imp qt)	—	8.3 (8.8, 7.3)	—
AT differential gear oil	ℓ (US qt, Imp qt)	—	1.2 (1.3, 1.1)	—
4WD rear differential gear oil	ℓ (US qt, Imp qt)	—		
Power steering fluid	ℓ (US qt, Imp qt)	0.7 (0.7, 0.6)		
Engine coolant	ℓ (US qt, Imp qt)	Approx. MT: 5.9 (6.2, 5.2) AT: 5.8 (6.1, 5.1)		

DSPD: Dry Single Plate Diaphragm

TC: Torque converter

*3: 5-forward speeds with synchromesh and 1-reverse speed

*4: Electronically controlled fully-automatic, 4-forward speeds and 1-reverse speed

SPECIFICATIONS

[S2A10] 1-1

4-DOOR SEDAN			TOURING WAGON			
2000	2200		2200			
4WD			FWD		4WD	
TURBO	GX		GX		GX	
MPFI 5MT	MPFI 5MT	MPFI 4AT	MPFI 5MT	MPFI 4AT	MPFI 5MT	MPFI 4AT

DSPD *6	DSPD *6	TC *4	DSPD *3	TC *4	DSPD *9	TC *4
3.545	3.545	2.785	3.545	2.785	3.545	2.785
1.947	2.111	1.483	2.111	1.483	2.111	1.483
1.366	1.448	1.000	1.448	1.000	1.448	1.000
0.972	1.088	0.729	1.088	0.729	1.088	0.729
0.780	0.871	—	0.871	—	0.871	—
3.416	3.416	2.696	3.416	2.696	3.416	2.696
—	—	—	—	—	1.000	—
—	—	—	—	—	1.196	—
—	—	Helical	—	Helical	—	Helical
—	—	1.000	—	1.000	—	1.000
Hypoid						
3.900	3.900	4.111	3.700	4.111	3.900	4.111
Helical	Helical	—	—	—	Helical	—
1.100	1.000	—	—	—	1.000	—
Hypoid			Hypoid			
3.545	3.900	4.111	—	—	3.900	4.111

Rack and pinion
3.3, 3.0 ... [TURBO]
Wall to wall: 11.0 (36.1)/Curb to curb: 10.2 (33.5) ... FWD, Curb to curb: 10.1 (33.1), 10.6 (34.8) [TURBO] ... 4WD

Macpherson strut type, Independent, Coil spring	*10
Dual link strut type, Independent, Coil spring	*11

Dual circuit hydraulic with vacuum suspended power unit	
Ventilated disc brake	Disc brake
Ventilated disc brake	Mechanical on rear brakes

205/60R15 91V	185/70R14 87H 185/70R14 88H
Steel belted radial, Tubeless	

60 (15.9, 13.2)						
4.5 (4.8, 4.0)						
3.5 (3.7, 3.1)						
3.5 (3.7, 3.1)	3.5 (3.7, 3.1)	—	3.3 (3.5, 2.9)	—	3.5 (3.7, 3.1)	—
—	—	8.3 (8.8, 7.3)	—	8.3 (8.8, 7.3)	—	8.3 (8.8, 7.3)
—	—	1.2 (1.3, 1.1)	—	1.2 (1.3, 1.1)	—	1.2 (1.3, 1.1)
0.8 (0.8, 0.7)			—		0.8 (0.8, 0.7)	
0.7 (0.7, 0.6)						
Approx. 7.2 (7.6, 6.3)		Approx. MT: 5.9 (6.2, 5.2) AT: 5.8 (6.1, 5.1)				

- *6: 5-forward speeds with synchromesh and 1-reverse speed — with center differential and viscous coupling
- *9: 5x2-forward speeds with synchromesh and 1-reverse speed — with center differential and viscous coupling
- *10: Macpherson strut type, Independent, Pneumatic suspension with height control
- *11: Dual link strut type, Independent, Pneumatic suspension with height control

SUBARU®

1992

**SERVICE
MANUAL**

	Page
1. GENERAL PRECAUTIONS	2
2. VEHICLE IDENTIFICATION NUMBER (V.I.N.)	9
3. IDENTIFICATION NUMBER AND LABEL LOCATIONS	12
4. RECOMMENDED FUEL, LUBRICANTS, SEALANTS AND ADHESIVES	14
5. TIGHTENING TORQUE OF STANDARD BOLTS AND NUTS	17
6. LIFTING, TOWING AND TIE-DOWN POINTS	18



1. General Precautions

A: BEFORE STARTING SERVICE

- 1) Be sure to perform the jobs listed in the Periodic Maintenance Schedule.
- 2) When a vehicle is brought in for maintenance, carefully listen to the owner's explanations of the symptoms exhibited by the vehicle. List the problems in your notebook, and refer to them when trying to diagnose the trouble.
- 3) All jewelry should be removed. Suitable work clothes should be worn.
- 4) Be sure to wear goggles.
- 5) Use fender, floor and seat covers to prevent the vehicle from being scratched or damaged.
- 6) Never smoke while working.
- 7) Before removing underfloor bolts (including the rear differential filler plug) coated with bituminous wax, remove old wax. Re-coat with new wax after reinstallation.

B: WHILE WORKING

- 1) When jacking up the vehicle, be sure to use safety stands.
- 2) When jacking up the front or rear end of the car body, be sure to chock the tires remaining in contact with the ground.
- 3) Keep the parking brake applied when working on the vehicle. Chock the tires remaining in contact with the ground (and set the selector lever to "P" position in AT vehicle), when the parking brake cannot be applied, such as when the brakes are being worked on.
- 4) Keep the ignition key turned "OFF" if at all possible.
- 5) Be cautious while working when the ignition key is "ON"; if the engine is hot, the cooling fan may start to operate.
- 6) While the engine is in operation, properly ventilate the workshop.
- 7) While the engine is in operation, be aware of any moving parts, such as the cooling fan and the drive belt.
- 8) Keep your hands off any metal parts such as the radiator, exhaust manifold, exhaust pipe, and muffler, to prevent burning yourself.
- 9) When servicing the electrical system or the fuel system, disconnect the ground cable from the battery.
- 10) When disassembling, arrange the parts in the order that they were disassembled.
- 11) When removing a wiring connector, do not pull the wire but pull the connector itself.
- 12) When removing a hose or tube, remove the clip first. Then, pull the hose or tube while holding its end fitting.
- 13) Replace gaskets, O-rings, snap rings, lock washers, etc. with new ones.

- 14) When tightening a bolt or nut, tighten it to the specified torque.
- 15) When performing work requiring special tools, be sure to use the designated ones.
- 16) After completing work, make certain that the hoses, tubes and wiring harnesses are securely connected.
- 17) After completing work, be sure to wash the vehicle.

C: TREATMENT FOR USED ENGINE OIL

1. ENGINE OILS

Prolonged and repeated contact with mineral oil will result in the removal of natural fats from the skin, leading to dryness, irritation and dermatitis. In addition, used engine oil contains potentially harmful contaminants which may cause skin cancer. Adequate means of skin protection and washing facilities should be provided.

2. HEALTH PROTECTION PRECAUTIONS

- 1) Avoid prolonged and repeated contact with oils, particularly used engine oils.
- 2) Wear protective clothing, including impervious gloves where practicable.
- 3) Do not put oily rags in pockets.
- 4) Avoid contaminating clothes, particularly underpants, with oil.
- 5) Overalls must be cleaned regularly. Discard unwashable clothing and oil impregnated footwear.
- 6) First Aid treatment should be obtained immediately for open cuts and wounds.
- 7) Use barrier creams, applying them before each work period, to help the removal of oil from the skin.
- 8) Wash with soap and water to ensure all oil is removed (skin cleansers and nail brushes will help). Preparations containing lanolin replace the natural skin oils which have been removed.
- 9) Do not use petrol, kerosene, diesel fuel, gas oil, thinners or solvents for washing skin.
- 10) If skin disorders develop, obtain medical advice.
- 11) Where practicable, degrease components prior to handling.
- 12) Where there is a risk of eye contact, eye protection should be worn, for example, chemical goggles or face shields; in addition an eye wash facility should be provided.

For the UK region, see also HSE Cautionary Notice SHW 397 Effects of Mineral Oil on the skin.

3. ENVIRONMENTAL PROTECTION PRECAUTIONS

It is illegal to pour used oil on to the ground, down sewers or drains, or into water courses. The burning of used engine oil in small space heaters or boilers is not recommended unless emission control equipment is

fit ted. If in doubt check with the Local Authority. Dispose of used oil through authorized waste disposal contractors, licensed waste disposal sites, or to the waste oil reclamation trade. If in doubt, contact the Local Authority for advice on disposal facilities.

D: PNEUMATIC SUSPENSION MODELS WITH HEIGHT CONTROL

These models are provided with height control mechanisms. Be sure to return the height control to "Normal" position (low) and support the vehicle with a jack before getting under it for servicing, etc. To check any system, other than electrical, under the vehicle, disconnect cables from battery in advance.

E: FULL-TIME 4WD MT MODELS

1. SPEEDOMETER TEST

■ Jack-up Method

- 1) Position vehicle so that front wheels are placed between rollers of speedometer test machine.
- 2) Jack up vehicle until rear wheels clear the floor, and support with safety stands.
- 3) Start engine with shift lever set in 2nd gear (for safety considerations). Perform speedometer tests.

a. Secure a rope or wire to the front towing hook to prevent the lateral runout of front wheels.

b. Do not abruptly depress/release clutch pedal or accelerator pedal during tests even when engine is operating at low speeds since this may cause vehicle to jump off test machine.

c. Avoid abrupt braking after tests.

d. In order to prevent the vehicle from slipping due to vibration, do not place any wooden blocks or similar items between the safety stands and the vehicle.

e. Since the rear wheels will also be rotating, do not place anything near them. Also, make sure that nobody goes in front of the vehicle.

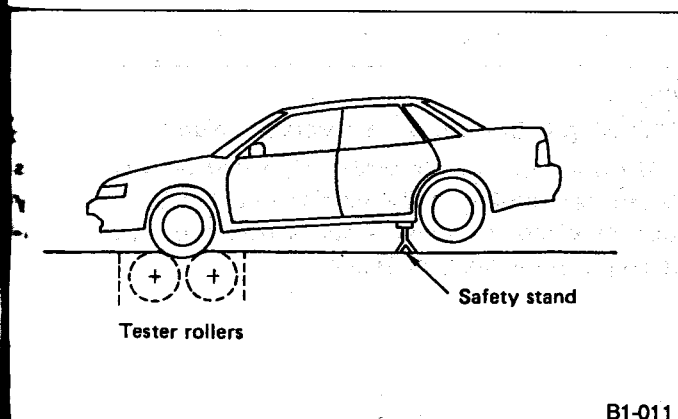


Fig. 1

■ Free roller method

- 1) Position vehicle so that front wheels are placed between rollers of test machine.
- 2) Scribe alignment mark corresponding with centerline of rear wheels on floor.
- 3) Back up vehicle so that centerline of free rollers are aligned with mark scribed in step 2 above.
- 4) Drive vehicle onto free rollers.
- 5) Perform speedometer tests.

a. Secure a rope or wire to the front towing hook to prevent the lateral runout of front wheels

b. Do not abruptly depress/release clutch pedal or accelerator pedal during tests even when engine is operating at low speeds since this may cause vehicle to jump off test machine.

c. Avoid abrupt braking after tests.

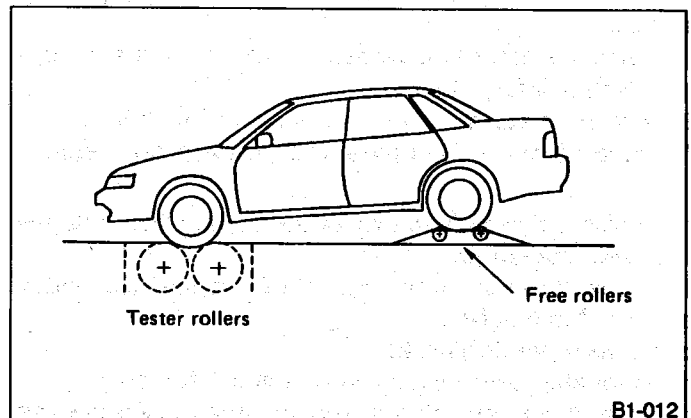


Fig. 2

2. BRAKE TEST

- 1) Drive vehicle for a distance of several kilometers (miles) to stabilize dragging force of viscous coupling.
- 2) Place vehicle onto brake tester.
- 3) Perform brake tests.

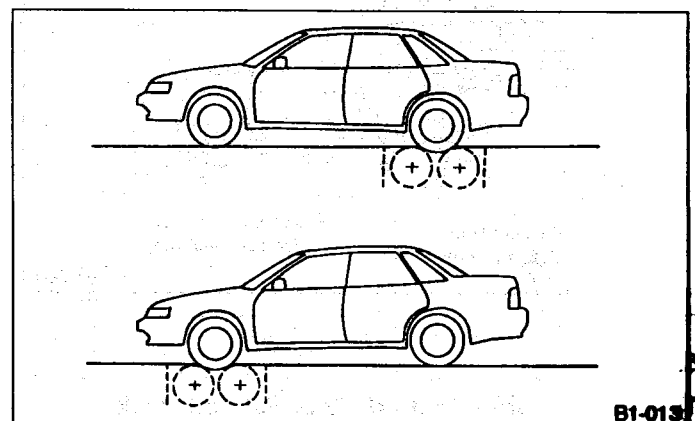


Fig. 3

If dragging force exceeds specifications, check brake pad or brake shoe for dragging. Abnormalities related to the viscous torque of viscous coupling unit

cause excessive dragging force. At this point, raise vehicle so that two front or rear wheels clear floor, remove cause of abnormality and check wheel rotation.

Effect of braking force on viscous coupling torque:

Approx. 245 N (25 kg, 55 lb)

3. CHASSIS DYNAMOMETER TEST

- 1) Locate vehicle onto chassis dynamometer tester.
- 2) Locate rear wheels onto free rollers.
- 3) Perform dynamic performance tests.
 - a. Do not abruptly depress/release clutch pedal or accelerator pedal during tests.
 - b. Avoid abrupt braking tests after tests.

4. TIRE BALANCE TEST (On-car machine)

- 1) Raise vehicle so that left and right wheels to be checked clear the floor. Support wheels using pick-up stands.
- 2) Raise the other two wheels off the ground and support with a safety stand.
- 3) Attach on-car machine to wheels to be checked.
- 4) Drive wheel with engine and perform tire balance tests.
 - a. Perform tire balance tests after each tire balance has been measured.
 - b. Locate the vehicle so that its front and rear sides are equal in height.
 - c. Release parking brake.
 - d. Manually rotate each tire and check for drag.
 - e. Do not operate clutch and do not accelerate the engine abruptly.
 - f. If error occurs due to engine operation, do not operate balance's motor.

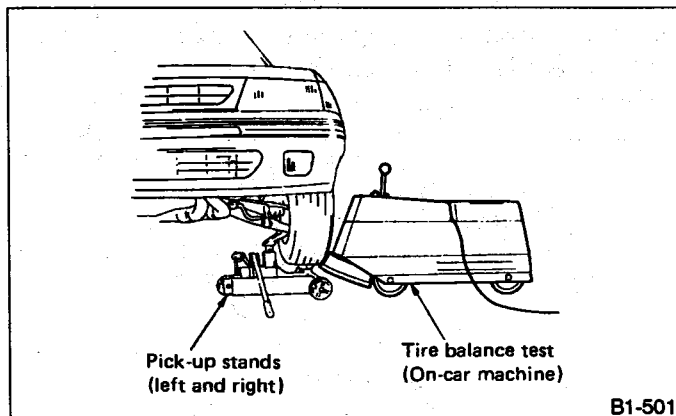


Fig. 4

5. TOWING

- 1) Loading vehicle onto dolly or flat-bed truck
 - a. Transport vehicle using a dolly or flat-bed truck whenever possible.
 - b. Move shift lever to "1st" and apply parking brake.

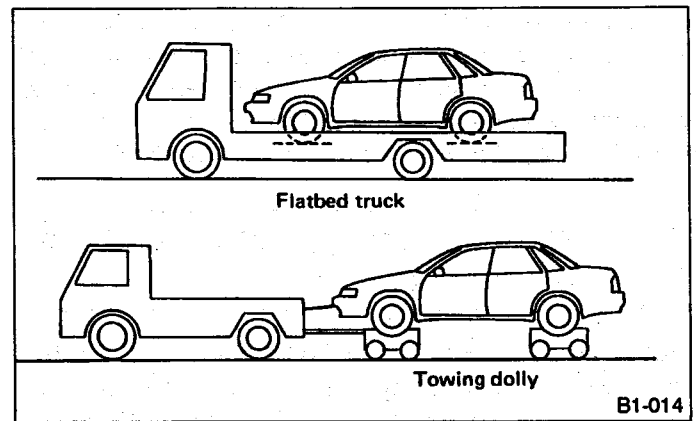


Fig. 5

- 2) Towing with a rope
 - a. Use a rope only when power train and all wheels are operating properly.
 - b. The ignition switch should be in the "ACC" position. Never have the ignition switch on "LOCK" while the vehicle is being towed because steering will not be possible, since the direction of the wheels will be locked.
 - c. Put the transmission in neutral.
 - d. Never use the tie down hooks for towing.
 - e. Remember that brake booster and power steering will not work when engine is "OFF". You will have to use greater effort for the brake pedal and steering wheel.
 - f. Before towing, check transmission oil and differential oil levels and top up to the specified level if necessary.

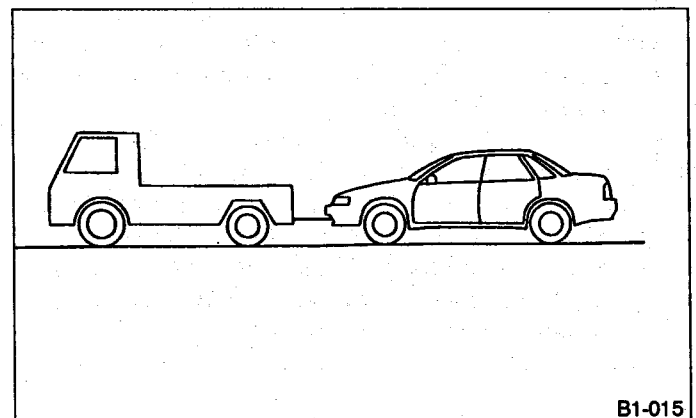
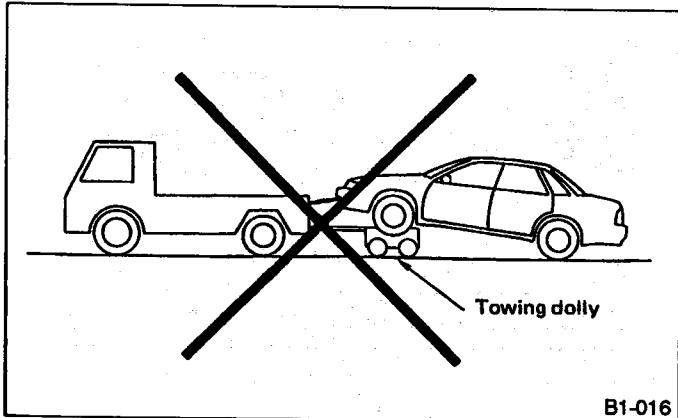


Fig. 6

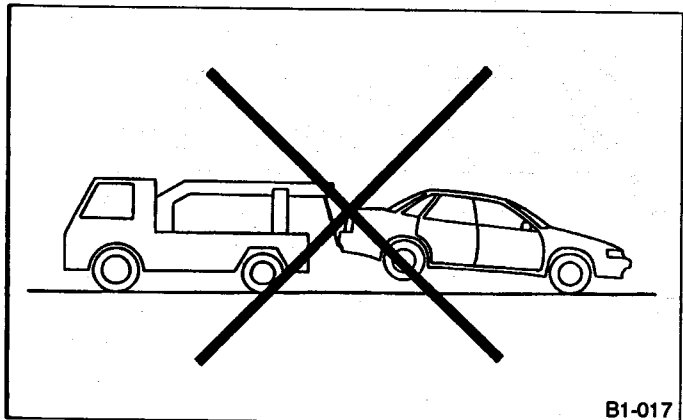
- 3) Towing with front or rear wheels raised
 - a. Do not tow vehicle with only front or rear wheels placed on towing dolly or flat-bed truck. This may degrade viscous coupling performance or cause vehicle to jump off dolly or truck.



B1-016

Fig. 7

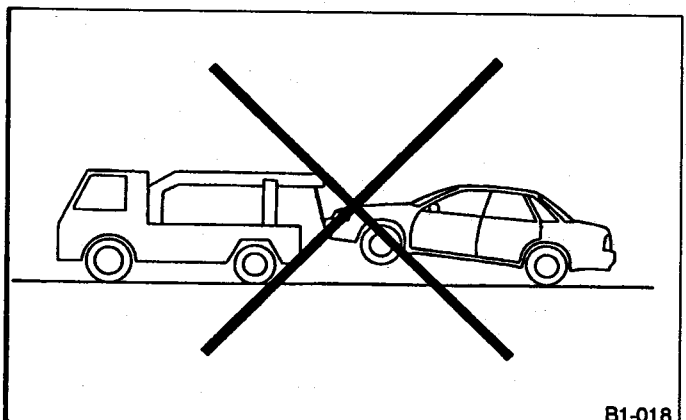
b. Do not tow vehicle with rear wheels raised under any circumstances since this will damage bumper.



B1-017

Fig. 8

c. Do not tow vehicle with front wheels raised under any circumstances since this will damage bumper.



B1-018

Fig. 9

F: FULL TIME 4WD AT MODELS

1. BEFORE CHECKING OR SERVICING CARS WITH THE FRONT WHEELS RAISED OR ON ROLLERS (BRAKE TESTER, CHASSIS DYNAMOMETER, ETC.)

Always set the car in the FWD mode.

To set the car in the FWD mode, disconnect the 4WD circuit by inserting a fuse in the FWD connector inside the engine compartment. Also chock the rear wheels firmly.

Ensure that the FWD pilot light is on. If the car is left in the 4WD mode, it will surge abruptly when the wheels turn, possibly damaging the transfer clutch.

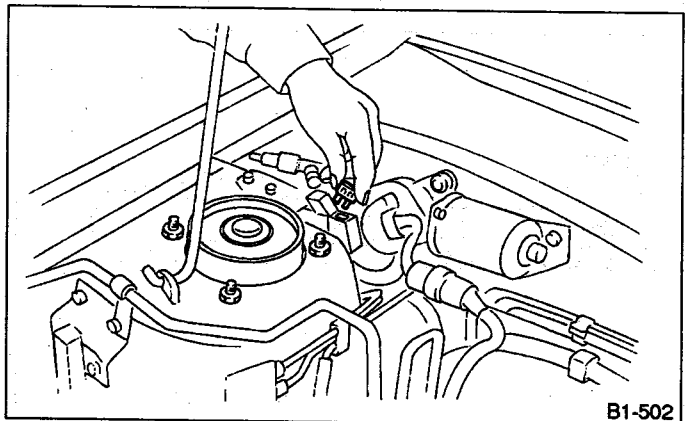


Fig. 10

2. TOWING

1) Loading vehicle onto dolly or flat-bed truck

a. Transport vehicle using a dolly or flat-bed truck whenever possible.

b. Place the selector lever in "P" position and apply the parking brake.

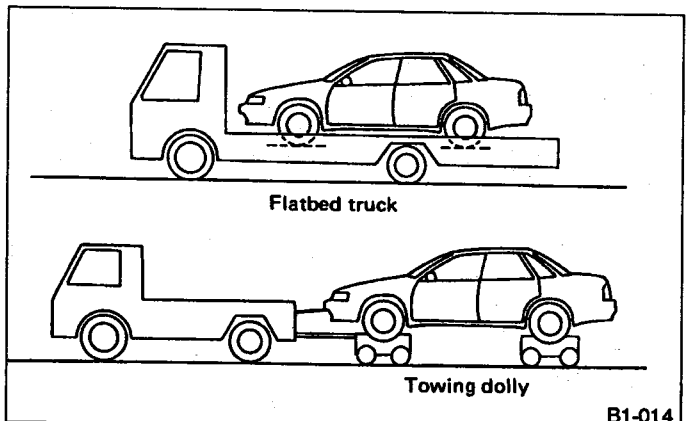


Fig. 11

2) Towing with a rope

a. Tow vehicle with a rope only when power train and all wheels are operating properly.

b. Put a spare fuse inside the FWD connector and never exceed 30 km/h (19 MPH). Also, do not tow for more than 10 km (6 miles).

c. Place the selector lever in "N" position.

d. The ignition switch should be in the "ACC" position while the vehicle is being towed. Never have the ignition switch on "LOCK" while the vehicle is being towed because steering will not be possible, since the direction of the wheels will be locked.

e. Never use the tie down hooks for towing.

f. Remember that brake booster and power steering will not work when the engine is "OFF". You will have to use greater effort for the brake pedal and steering wheel.

g. Before towing, check transmission oil and differential oil levels and top up to the specified level if necessary.

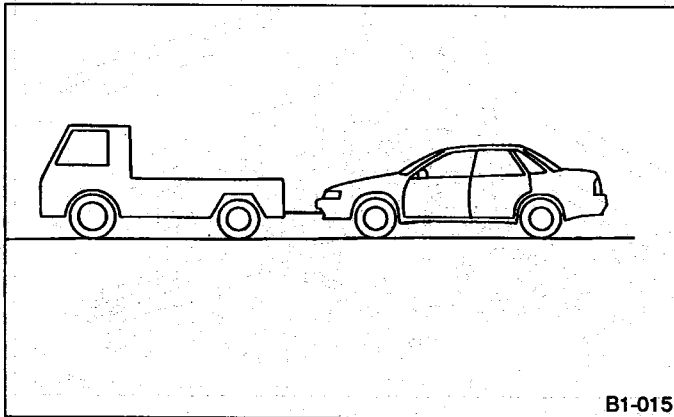


Fig. 12

3) Towing with front or rear wheels raised

Do not tow vehicle with front or rear wheels raised under any circumstances since this will damage bumper.

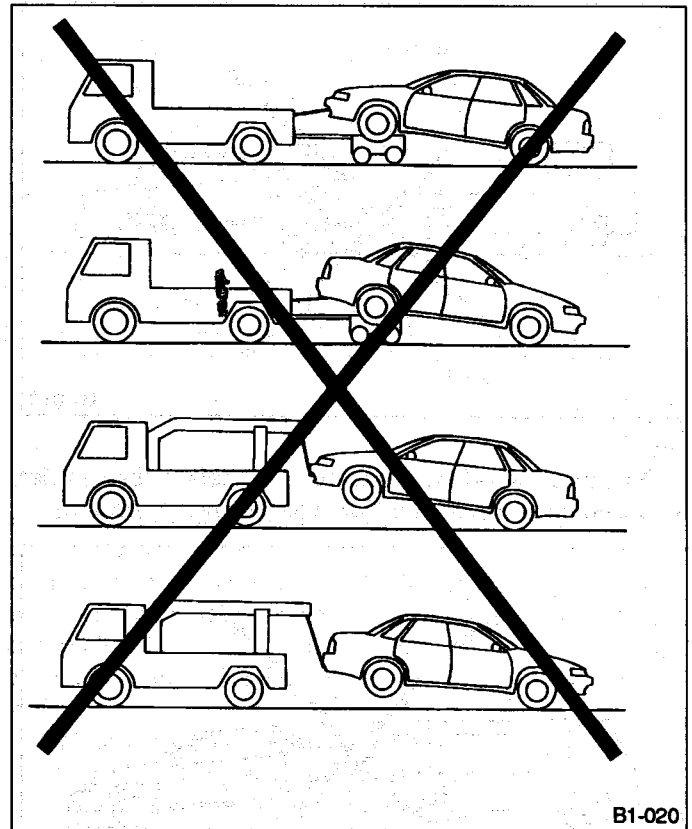


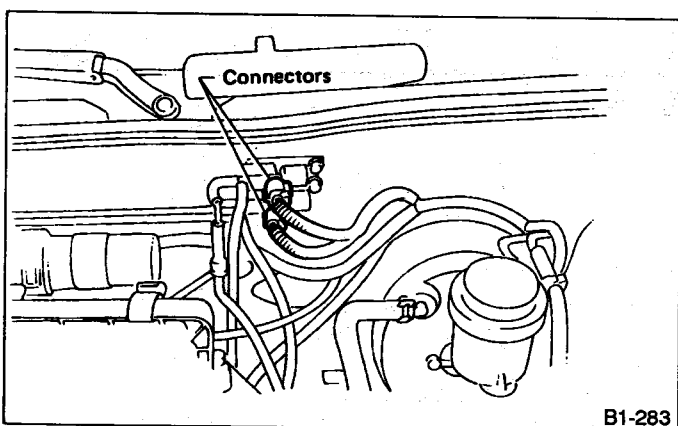
Fig. 13

G: SELECTIVE 4WD MT MODELS

1. BEFORE CHECKING OR SERVICING CARS WITH THE FRONT WHEELS RAISED OR ON ROLLERS (BRAKE TESTER, CHASSIS DYNAMOMETER, ETC.)

Always set the car in the FWD mode.

Be sure to set 4WD selector switch to OFF. In addition, disconnect harness connector for 4WD solenoid valve inside engine compartment and chock rear wheels firmly.



B1-283

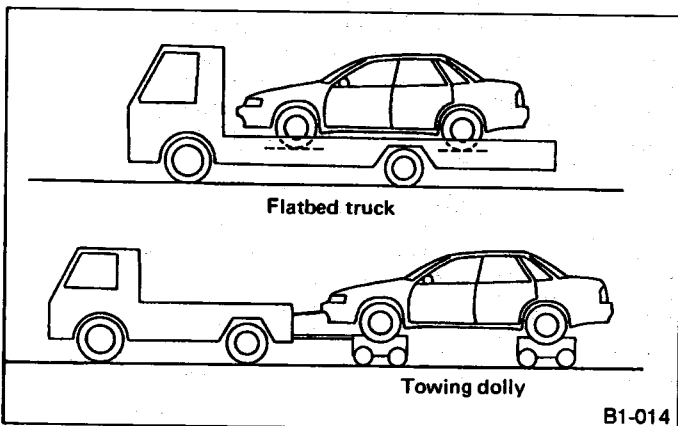
Fig. 14

2. TOWING

1) Loading vehicle onto dolly or flat-bed truck

a. Transport vehicle using a dolly or flat-bed truck whenever possible.

b. Move shift lever to "1st" position and apply parking brake.



B1-014

Fig. 15

2) Towing with a rope

a. Use a rope only when power train and all wheels are operating properly.

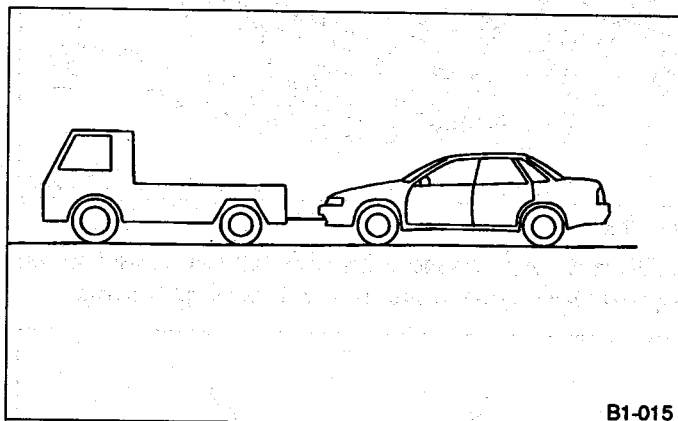
b. The ignition switch should be in the "ACC" position. Never have the ignition switch on "LOCK" while the vehicle is being towed because steering will not be possible, since the direction of the wheels will be locked.

c. Put the transmission in neutral.

d. Never use the tie down hooks for towing.

e. Remember that brake booster and power steering will not work when engine is "OFF". You will have to use greater effort for the brake pedal and steering wheel.

f. Before towing, check transmission oil and differential oil levels and top up to the specified level if necessary.

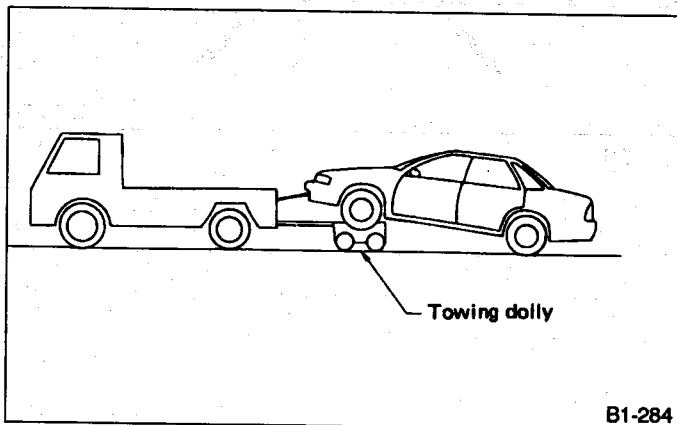


B1-015

Fig. 16

3) Towing with front or rear wheels raised

a. When towing vehicle with only front wheels placed on towing dolly or flat-bed truck, set the vehicle in the FWD mode.



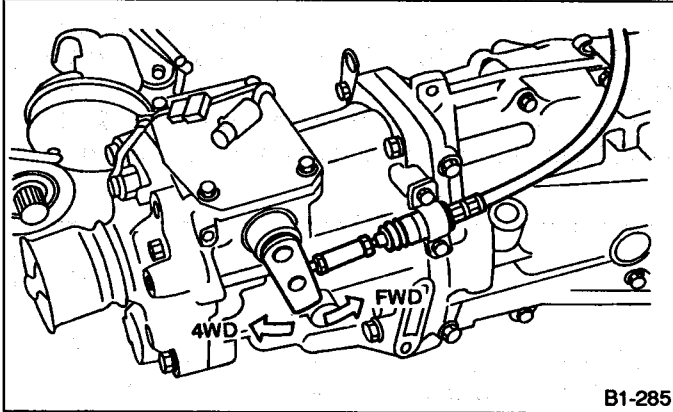
B1-284

Fig. 17

■4WD mode canceling method

1) Under normal circumstances, start the engine, turn the 4WD selector switch off and, with the tires pointed straight ahead, move the vehicle either forward or backward.

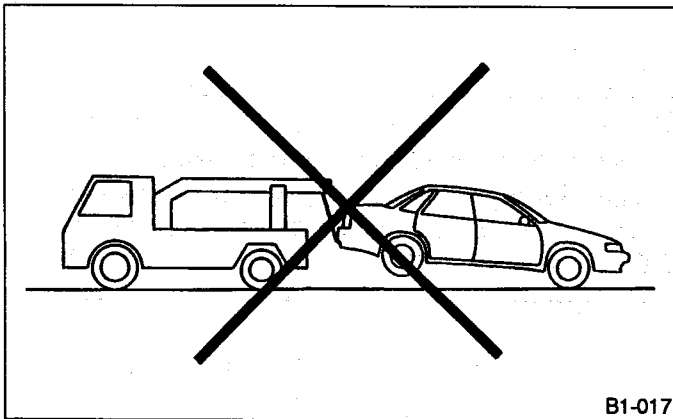
2) If the engine cannot be started, such as when the battery is dead or when the vacuum actuator is not working, raise the front (or rear) wheels and move the transfer shift lever, on the right side of the transmission, towards the rear of the vehicle.



B1-285

Fig. 18

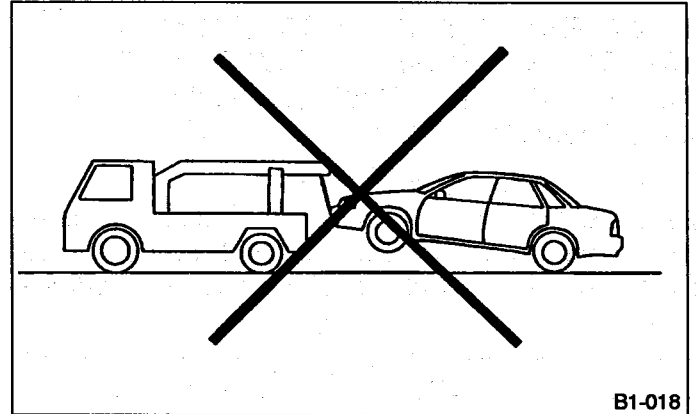
b. Do not tow vehicle with rear wheels raised under any circumstances since this will damage bumper.



B1-017

Fig. 19

c. Do not tow vehicle with front wheels raised under any circumstances since this will damage bumper.



B1-018

Fig. 20

2. Vehicle Identification Number (V.I.N.)

A: APPLICABLE V.I.N. IN THIS MANUAL

3. EXCEPT AUSTRALIA MODELS

4-DOOR SEDAN	1600 cc engine	DL	Carb., 5MT	J	F	1	B	C	H	C	R	O	C	B	0	1	5	0	0	1	and after
		GL	Carb., 5MT	J	F	1	B	C	H	C	R	O	C	B	0	1	5	0	0	1	and after
	1800 cc engine	DL	Carb., 5MT	J	F	1	B	C	2	C	R	O	C	B	0	1	5	0	0	1	and after
		GL	Carb., 5MT	J	F	1	B	C	2	C	R	O	C	B	0	1	5	0	0	1	and after
			Carb., 4AT	J	F	1	B	C	2	C	R	O	C	K	0	1	5	0	0	1	and after
		Full time 4WD GL	Carb., 5MT SR	J	F	1	B	C	3	C	R	O	C	G	0	1	5	0	0	1	and after
	Carb., 4AT		J	F	1	B	C	3	C	R	O	C	H	0	1	5	0	0	1	and after	
	2000 cc engine	Full time 4WD GL	MPFI, 5MT SR	J	F	1	B	C	5	C	R	O	E	G	0	1	5	0	0	1	and after
			MPFI, 4AT	J	F	1	B	C	5	C	R	O	E	H	0	1	5	0	0	1	and after
	2000 cc DOHC engine	Full time 4WD TURBO	MPFI, 5MT SR	J	F	1	B	C	5	C	R	O	B	G	0	1	5	0	0	1	and after
			MPFI, 5MT	J	F	1	B	C	6	C	R	O	E	B	0	1	5	0	0	1	and after
	2200 cc engine	GX	MPFI, 4AT	J	F	1	B	C	6	C	R	O	E	K	0	1	5	0	0	1	and after
MPFI, 5MT SR			J	F	1	B	C	7	C	R	O	E	G	0	1	5	0	0	1	and after	
Full time 4WD GX		MPFI, 4AT	J	F	1	B	C	7	C	R	O	E	H	0	1	5	0	0	1	and after	
		MPFI, 5MT SR	J	F	1	B	C	7	C	R	O	E	H	0	1	5	0	0	1	and after	
STATION WAGON	1600 cc engine	DL	Carb., 5MT	J	F	1	B	J	H	C	R	O	C	B	0	0	4	0	0	1	and after
		GL	Carb., 5MT	J	F	1	B	J	H	C	R	O	C	B	0	0	4	0	0	1	and after
	1800 cc engine	DL	Carb., 5MT	J	F	1	B	J	2	C	R	O	C	B	0	0	4	0	0	1	and after
		GL	Carb., 5MT	J	F	1	B	J	2	C	R	O	C	B	0	0	4	0	0	1	and after
			Carb., 4AT	J	F	1	B	J	2	C	R	O	C	K	0	0	4	0	0	1	and after
		Selective 4WD DL	Carb., 5MT DR	J	F	1	B	J	3	C	R	O	C	E	0	0	4	0	0	1	and after
	SPFI, 5MT DR		J	F	1	B	J	3	C	R	O	E	E	0	0	4	0	0	1	and after	
	2000 cc engine	Selective 4WD DL	MPFI, 5MT DR	J	F	1	B	J	5	C	R	O	E	E	0	0	4	0	0	1	and after
TOURING WAGON	1800 cc engine	Full time 4WD GL	Carb., 5MT DR	J	F	1	B	F	3	C	R	O	C	J	0	1	2	5	0	1	and after
			Carb., 4AT	J	F	1	B	F	3	C	R	O	C	H	0	1	2	5	0	1	and after
	2000 cc engine	Full time 4WD GL	MPFI, 5MT DR	J	F	1	B	F	5	C	R	O	E	J	0	1	2	5	0	1	and after
			MPFI, 4AT	J	F	1	B	F	5	C	R	O	E	H	0	1	2	5	0	1	and after
	2000 cc DOHC engine	Full time 4WD TURBO	MPFI, 5MT SR	J	F	1	B	F	5	C	R	O	B	G	0	1	2	5	0	1	and after
	2200 cc engine	Full time 4WD GX	MPFI, 5MT DR	J	F	1	B	F	7	C	R	O	E	J	0	1	2	5	0	1	and after
			MPFI, 5MT DR	J	F	1	B	F	B	C	R	O	E	J	0	1	2	5	0	1	and after
			MPFI, 4AT	J	F	1	B	F	B	C	R	O	E	H	0	1	2	5	0	1	and after

Single-range
Dual-range

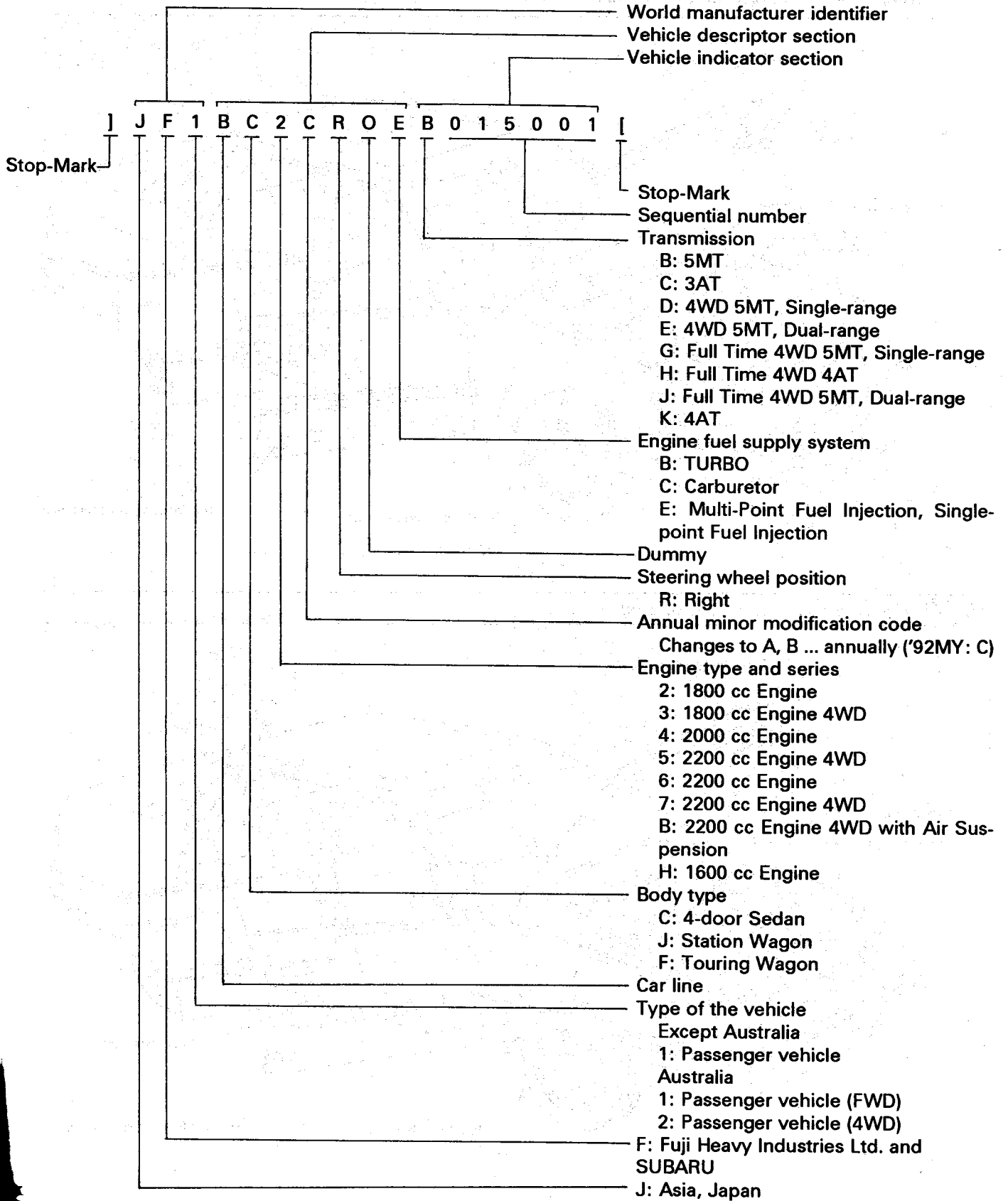
2. AUSTRALIA MODELS

4-DOOR SEDAN	2000 cc DOHC engine	Full time 4WD TURBO	MPFI, 5MT SR	J	F	2	B	C	5	C	R	O	B	G	0	1	5	0	0	1	and after
	2200 cc engine	LX	MPFI, 5MT	J	F	1	B	C	6	C	R	O	E	B	0	1	5	0	0	1	and after
			MPFI, 4AT	J	F	1	B	C	6	C	R	O	E	K	0	1	5	0	0	1	and after
		GX	MPFI, 5MT	J	F	1	B	C	6	C	R	O	E	B	0	1	5	0	0	1	and after
			MPFI, 4AT	J	F	1	B	C	6	C	R	O	E	K	0	1	5	0	0	1	and after
		Full time 4WD GX	MPFI, 5MT SR	J	F	2	B	C	7	C	R	O	E	J	0	1	5	0	0	1	and after
			MPFI, 4AT	J	F	2	B	C	7	C	R	O	E	H	0	1	5	0	0	1	and after
	TOURING WAGON	2200 cc engine	GX	MPFI, 5MT	J	F	1	B	F	6	C	R	O	E	B	0	1	2	5	0	1
MPFI, 4AT				J	F	1	B	F	6	C	R	O	E	K	0	1	2	5	0	1	and after
Full time 4WD GX			MPFI, 5MT DR	J	F	2	B	F	B	C	R	O	E	J	0	1	2	5	0	1	and after
			MPFI, 4AT	J	F	2	B	F	B	C	R	O	E	H	0	1	2	5	0	1	and after

SR: Single-range

DR: Dual-range

B: THE MEANING OF V.I.N.



3. Identification Number and Label Locations

Engine, transmission and vehicle identification numbers are used for factory communications such as Technical information, Service bulletins and other information.

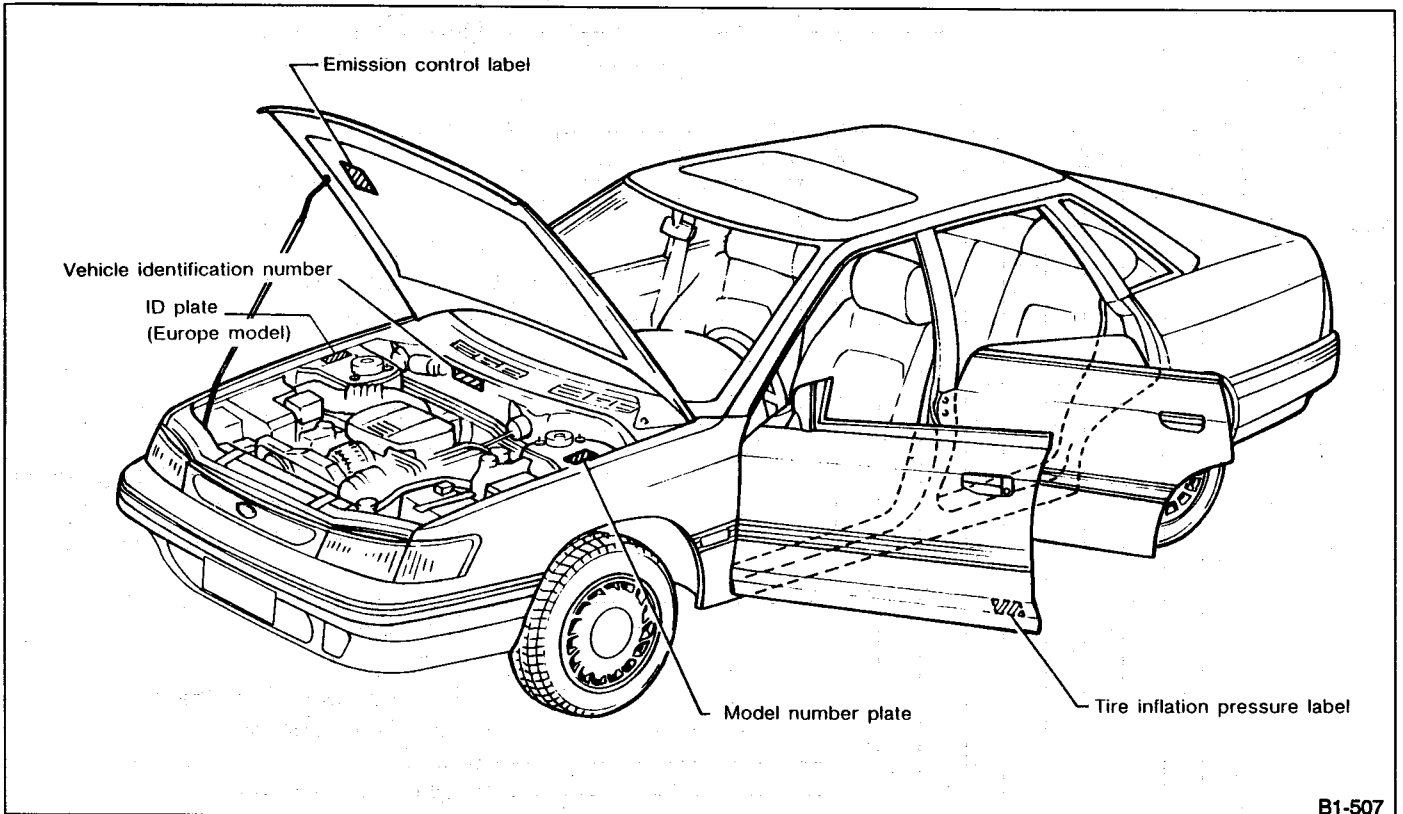


Fig. 21 For all models (except Australia)

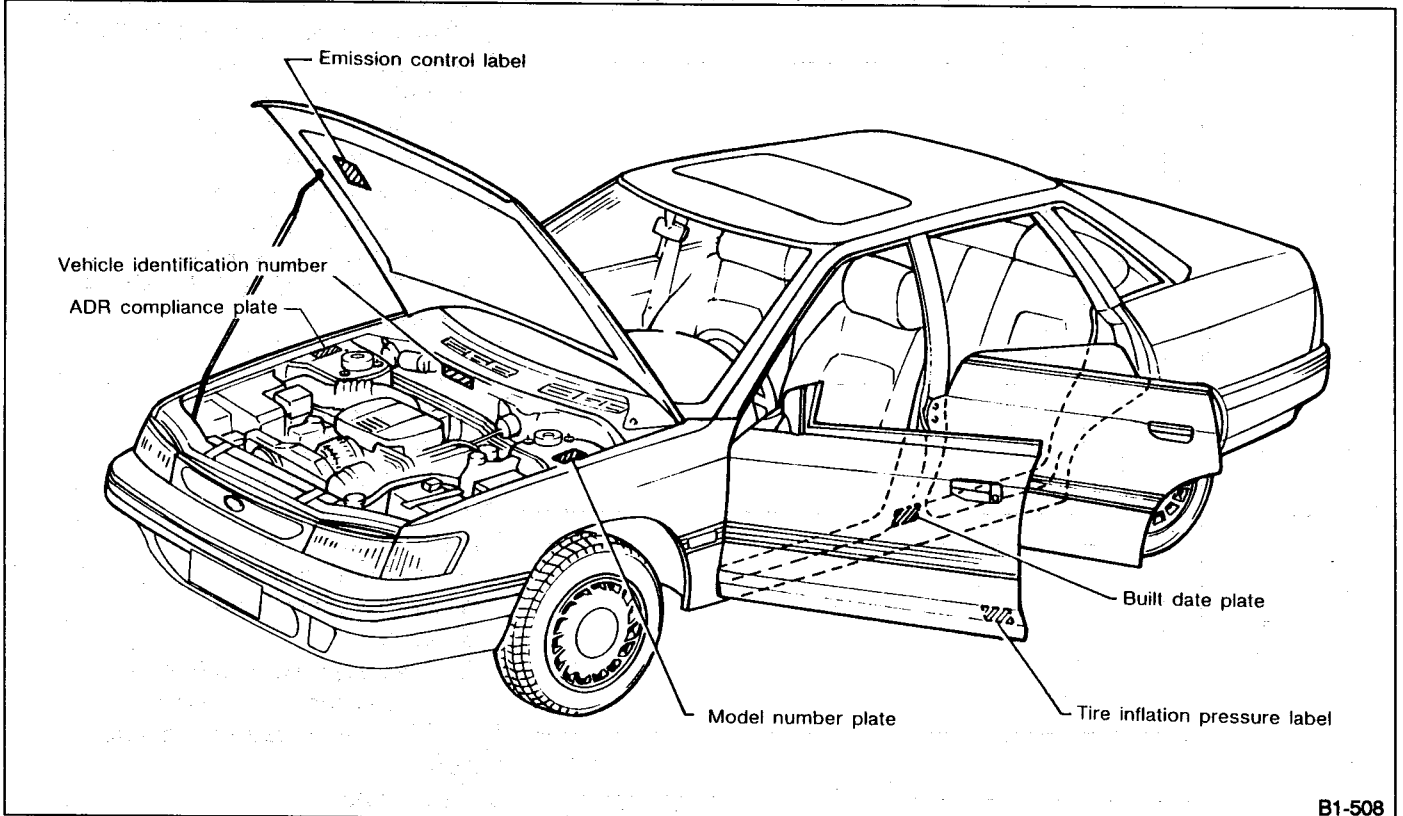


Fig. 22 For Australia model

GENERAL INFORMATION

[0300] 1-3

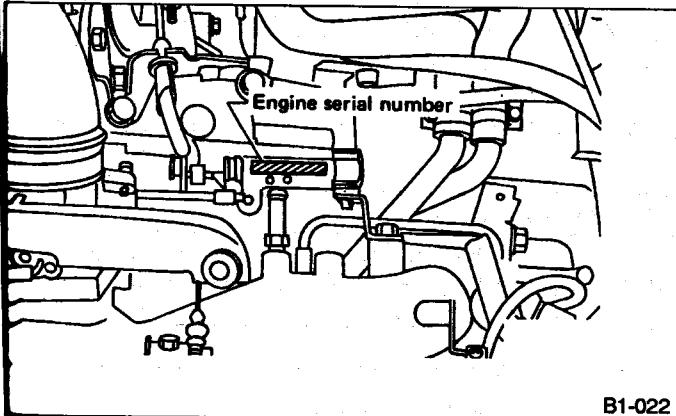


Fig. 23

B1-022

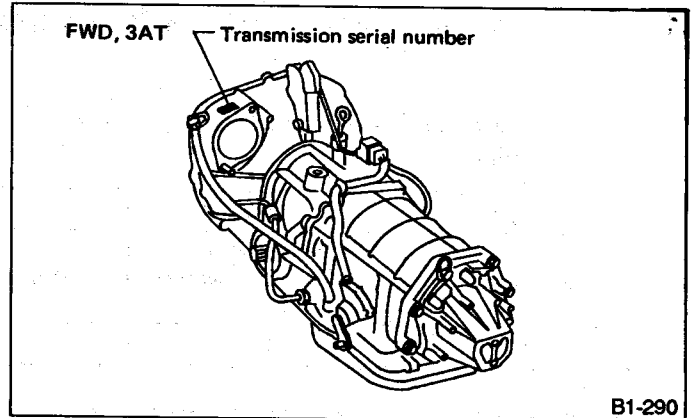


Fig. 26

B1-290

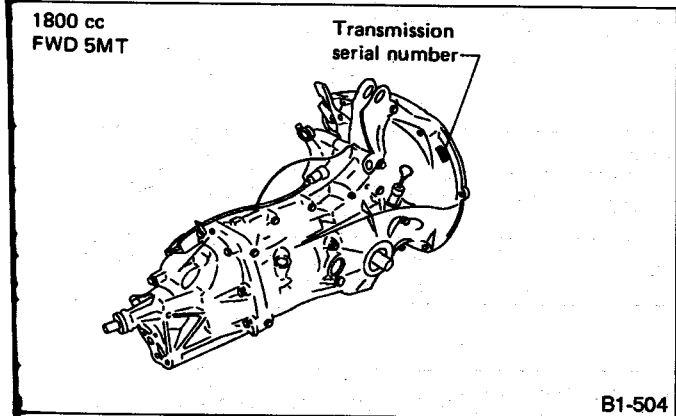


Fig. 24

B1-504

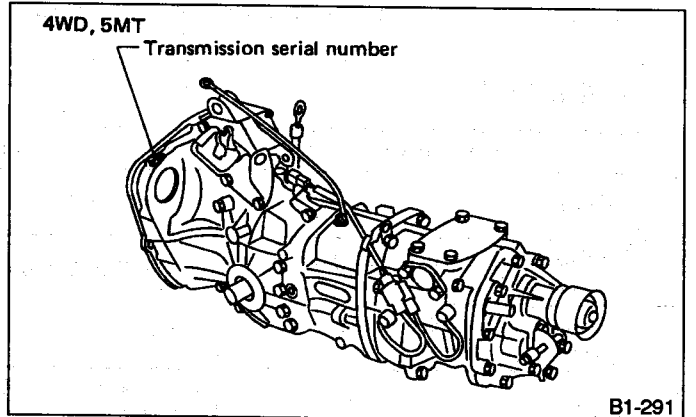


Fig. 27

B1-291

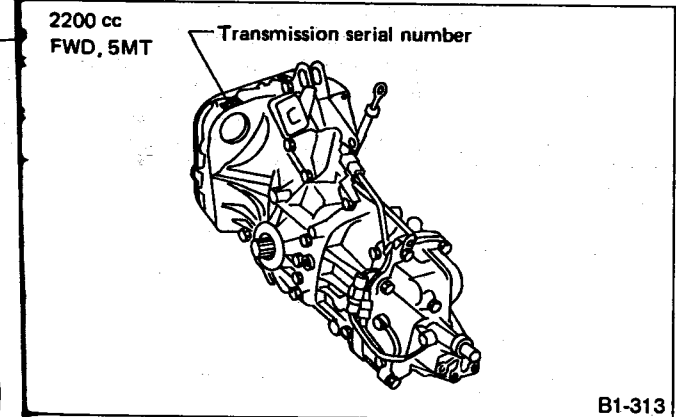


Fig. 25

B1-313

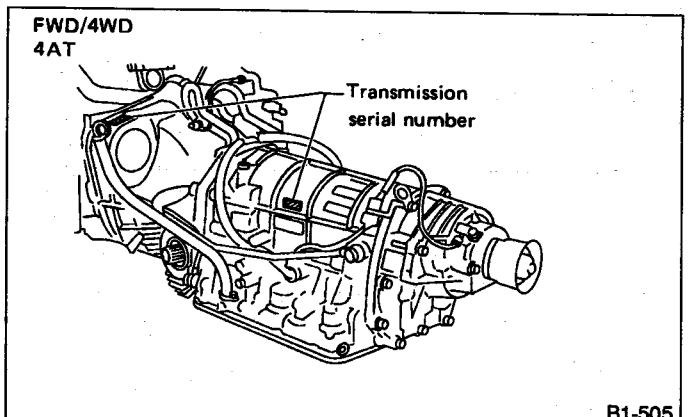


Fig. 28

B1-505

4. Recommended Fuel, Lubricants, Sealants and Adhesives

1. FUEL

The SUBARU engines are designed to give satisfactory engine performance and low exhaust emissions using the following gasoline.

Carburetor	SPFI	MPFI (NON-TURBO)		TURBO
Without catalyst	With catalyst (Use unleaded gasoline only)	Without catalyst	With catalyst (Use unleaded gasoline only)	With catalyst (Use unleaded gasoline only)
90*	90	90	90	95

*: If gasoline with an octane number between 83 and 89 is used, adjust ignition timing.

- a. Use gasoline of at least the octane number (RON) indicated in the table above.
- b. For models without catalyst, either leaded or unleaded gasoline may be used.

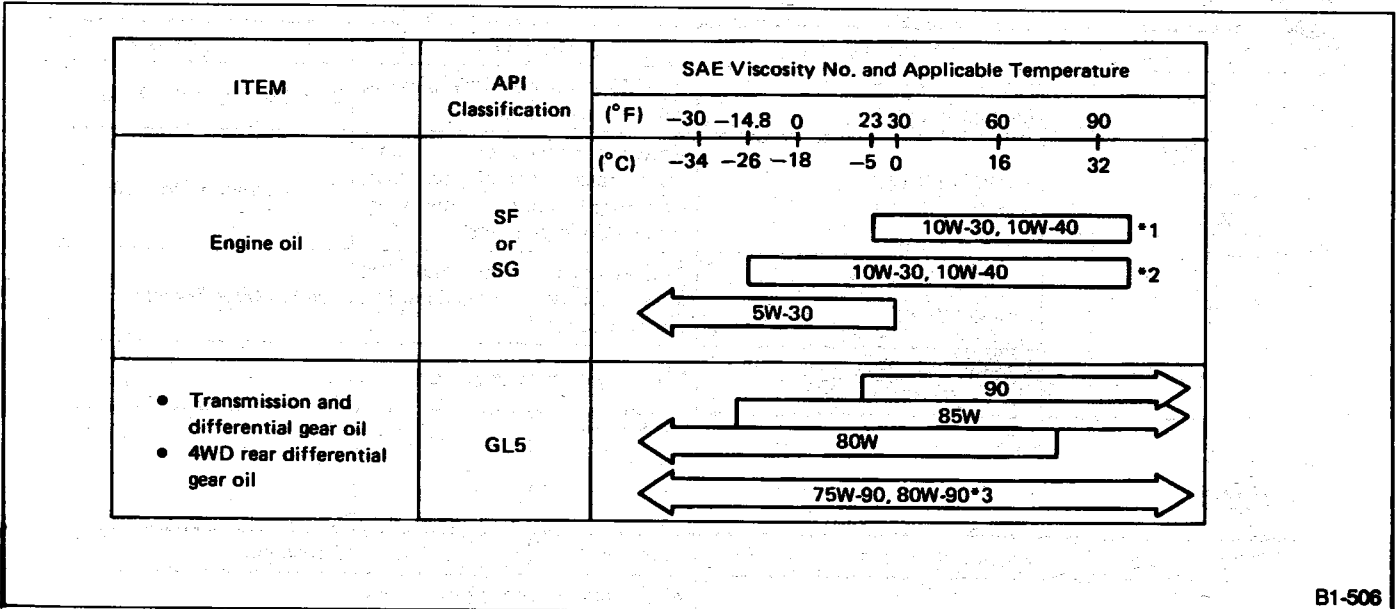
2. LUBRICANTS

Lubricants	Specifications	Remarks
<ul style="list-style-type: none"> • Engine oil 	<ul style="list-style-type: none"> • API Classification: SF or SG 	<ul style="list-style-type: none"> • For SAE viscosity number, refer to the following table.
<ul style="list-style-type: none"> • Transmission and differential gear oil • 4WD rear differential gear oil 	<ul style="list-style-type: none"> • API Classification: GL-5 	<ul style="list-style-type: none"> • For SAE viscosity number, refer to the following table.
<ul style="list-style-type: none"> • Automatic transmission and power steering fluid 	<ul style="list-style-type: none"> • DEXRON II 	—
<ul style="list-style-type: none"> • Coolant 	<ul style="list-style-type: none"> • Genuine SUBARU Coolant (Part No. 000016218) (Anti-freeze, anti-corrosive ethylene glycol base) 	<ul style="list-style-type: none"> • For further coolant specifications, refer to the following table.
<ul style="list-style-type: none"> • Brake fluid 	<ul style="list-style-type: none"> • DOT3 or DOT4 	<ul style="list-style-type: none"> • FMVSS NO. 116 • Avoid mixing brake fluid of different brands to prevent the fluid performance from degrading. • When brake fluid is added, be careful not to allow any dust into the reservoir.

GENERAL INFORMATION

[0402] 1-3

Lubricants	Recommended	Application	Equivalent
• Spray lubricants	SUBARU CRC (P/N 004301003)	O ₂ sensor, TURBO unit	
• Grease	SUNLIGHT 2 (P/N 003602010)	Steering shaft bearing, bushing for manual transmission gear shift system	—
	Valiant grease M-2 (P/N 003608001)	Steering gearbox	—
	Niglube RX-2 (P/N 003606000 or 725191040)	Piston boot of disc brake and sliding pin	—
	Molykote No. 7439 (P/N 725191460)	Contacting surfaces of drum brake shoes and shoe clearance adjuster	—
	Molylex No. 2 (P/N 723223010)	BJ and DOJ (for MT) joints of axle shafts	—
	VU-3A702 (P/N 623029980)	DOJ (for AT) joints of axle shafts	—
	FX clutch grease (P/N 000040901)	Splines of transmission main shaft	—
	Slicolube G-30M (P/N 004404002)	Control cables and carburetor linkages subject to cold weather, water-pump impeller, door latch, striker, battery terminals etc.	—



B1-506

Fig. 29

- *1: For Carburetor engine
- *2: For SPFI,MPFI and TURBO engine

- a. Each oil manufacturer has its base oil and additives. Thus, do not mix two or more brands (Except engine oil).
- b. When replenishing oil, it does not matter if the oil to be added is a different brand from that in the engine, however, use oil having the API classification and SAE viscosity No. designated by SUBARU.
- c. SAE 5W-30 is not recommended for sustained high speed driving.
- d. If vehicle is used in desert areas or areas with very high temperatures or for other heavy duty applications, the following viscosity oils may be used:
30,40,10W-50,20W-40,20W-50
- e. *3 For differential gear oil (AT)

Coolant Specifications							
Lowest anticipated atmospheric temperature	SUBARU coolant-to- *water ratio (Volume) %	Specification gravity					Freezing point
		at 10°C (50°F)	at 20°C (68°F)	at 30°C (86°F)	at 40°C (104°F)	at 50°C (122°F)	
Above - 30°C (- 22°F)	50 — 50	1.084	1.079	1.074	1.068	1.062	- 36°C (- 33°F)
Above - 15°C (- 5°F)	30 — 70	1.053	1.049	1.044	1.039	1.034	- 16°C (- 3°F)

* It is commended that distilled water be used.

- a. Avoid using any coolant or only water other than this designated type to prevent corrosion.
- b. SUBARU's engine is aluminum alloy, and so special care is necessary.

3. SEALANTS

	Recommended	Application	Equivalent
Sealant	Three Bond 1105 (P/N 004403010)	Rear differential oil drain plug, oil pressure switch, etc.	Dow Corning's No. 7038
	Three Bond 1215 (P/N 004403007)	Matching surface of oil pump, crank case, transmission case, etc. Engine service hole plug, coolant drain plug, etc.	Dow Corning's No. 7038
	Starcalking B-33A (P/N 000018901)	Sealing against water and dust entry through weatherstrips, grommets, etc.	Butyl Rubber Sealant
	Three Bond 1207C (P/N 004403012)	Matching surface of oil pan	—

4. ADHESIVES

	Recommended	Application	Equivalent
Adhesive	Cemedine 5430L	Weatherstrips and other rubber parts, plastics and textiles except soft vinyl parts.	3M's EC-1770 EC-1368
	Cemedine 540	Soft vinyl parts, and other parts subject to gasoline, grease or oil. e.g. trim leather, gear shift boot, door inner remote cover, etc.	3M's EC-776 EC-847 EC-1022 (Spray Type)
	Cemedine 3000	Bonding metals, glass, plastic and rubber parts. Repairing slightly torn weatherstrips, etc.	Armstrong's Eastman 910
	Essex Chemical Corp's Urethane E	Windshield to body panel.	Sunstar 580

GENERAL INFORMATION

[0502] 1-3

5. Tightening Torque of Standard Bolts and Nuts







1. ENGINE AND TRANSMISSION

Unit: N*m (kg-m, ft-lb)

Dia. x Pitch (mm)	5T	7T	9T	10T
4 x 0.75	1.0 — 1.5 (0.105 — 0.155, 0.8 — 1.1)	1.5 — 2.0 (0.155 — 0.205, 1.1 — 1.5)	2.5 — 3.0 (0.255 — 0.305, 1.8 — 2.2)	3.0 — 3.5 (0.305 — 0.355, 2.2 — 2.6)
5 x 0.9	2.5 — 3.0 (0.255 — 0.305, 1.8 — 2.2)	2.9 — 3.9 (0.30 — 0.40, 2.2 — 2.9)	4.9 — 5.9 (0.50 — 0.60, 3.6 — 4.3)	5.4 — 6.4 (0.55 — 0.65, 4.0 — 4.7)
6 x 1.0	4.4 — 5.4 (0.45 — 0.55, 3.3 — 4.0)	5.9 — 6.9 (0.60 — 0.70, 4.3 — 5.1)	9.4 — 10.8 (0.955 — 1.105, 6.9 — 8.0)	10 — 12 (1.0 — 1.2, 7 — 9)
8 x 1.25	12 — 14 (1.2 — 1.4, 9 — 10)	14.2 — 17.2 (1.45 — 1.75, 10.5 — 12.7)	23 — 26 (2.3 — 2.7, 17 — 20)	25 — 28 (2.5 — 2.9, 18 — 21)
10 x 1.25	25 — 28 (2.5 — 2.9, 18 — 21)	30 — 36 (3.1 — 3.7, 22 — 27)	46 — 54 (4.7 — 5.5, 34 — 40)	49.5 — 58.4 (5.05 — 5.95, 36.5 — 43.0)
12 x 1.5	41 — 49 (4.2 — 5.0, 30 — 36)	53 — 63 (5.4 — 6.4, 39 — 46)	84 — 98 (8.6 — 10.0, 62 — 72)	88 — 106 (9.0 — 10.8, 65 — 78)
14 x 1.6	71 — 84 (7.2 — 8.6, 52 — 62)	88 — 106 (9.0 — 10.8, 65 — 78)	139 — 165 (14.2 — 16.8, 103 — 122)	147 — 175 (15.0 — 17.8, 108 — 129)

BODY

Unit: N*m (kg-m, ft-lb)

		Dia. (mm)	4T	7T	9T
  	B1-026	4	1.7 — 2.6 (0.17 — 0.27, 1.2 — 2.0)	—	—
		5	2.9 — 5.9 (0.30 — 0.60, 2.2 — 4.3)	—	—
		6	5.4 — 9.3 (0.55 — 0.95, 4.0 — 6.9)	—	—
		8	12.7 — 22.6 (1.30 — 2.30, 9.4 — 16.6)	22.6 — 42.2 (2.30 — 4.30, 16.6 — 31.1)	31.4 — 51.0 (3.20 — 5.20, 23.1 — 37.6)
		10	27.5 — 47.1 (2.80 — 4.80, 20.3 — 34.7)	51.0 — 86.3 (5.20 — 8.80, 37.6 — 63.7)	62.8 — 107.9 (6.40 — 11.00, 46.3 — 79.6)
  	B1-027	4	1.2 — 2.2 (0.12 — 0.22, 0.9 — 1.6)	—	—
		5	2.5 — 4.4 (0.25 — 0.45, 1.8 — 3.3)	—	—
		6	4.4 — 7.4 (0.45 — 0.75, 3.3 — 5.4)	—	—
		8	9.8 — 17.7 (1.00 — 1.80, 7.2 — 13.0)	17.7 — 31.4 (1.80 — 3.20, 13.0 — 23.1)	23.5 — 39.2 (2.40 — 4.00, 17.4 — 28.9)
		10	22.6 — 36.3 (2.30 — 3.70, 16.6 — 26.8)	37.3 — 66.7 (3.80 — 6.80, 27.5 — 49.2)	48.1 — 83.4 (4.90 — 8.50, 35.4 — 61.5)
31		12	39.2 — 64.7 (4.00 — 6.60, 28.9 — 47.7)	68.6 — 117.7 (7.00 — 12.00, 50.6 — 86.8)	88.3 — 147.1 (9.00 — 15.00, 65.1 — 108.5)

mark is embossed on the bolt head as follows:

- 4 9T — 9
- 5 10T — 10
- 7

6. Lifting, Towing and Tie-down Points

Be sure to lift, tow and tie-down the vehicle at the designated positions.

1. GARAGE JACK

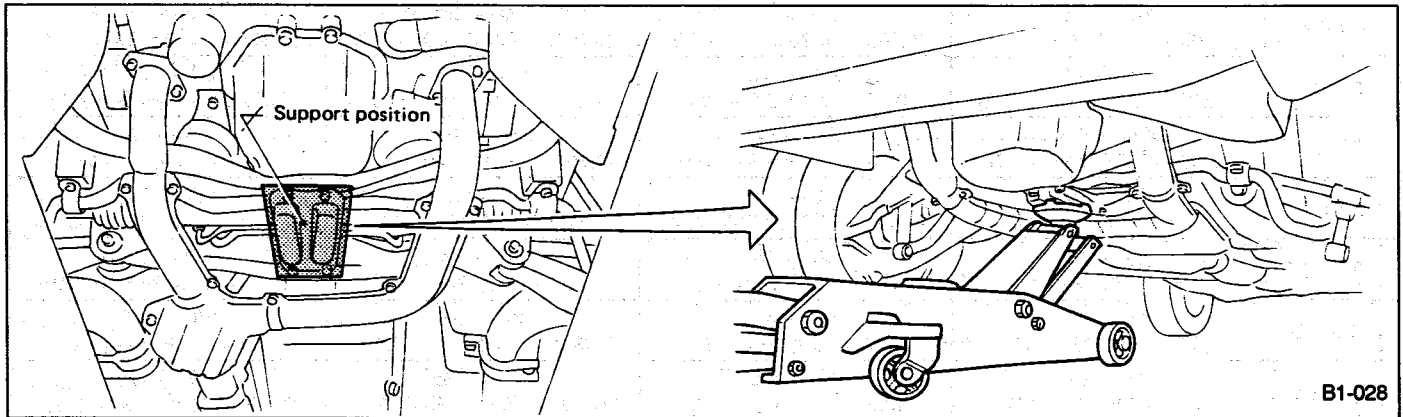


Fig. 32 Front

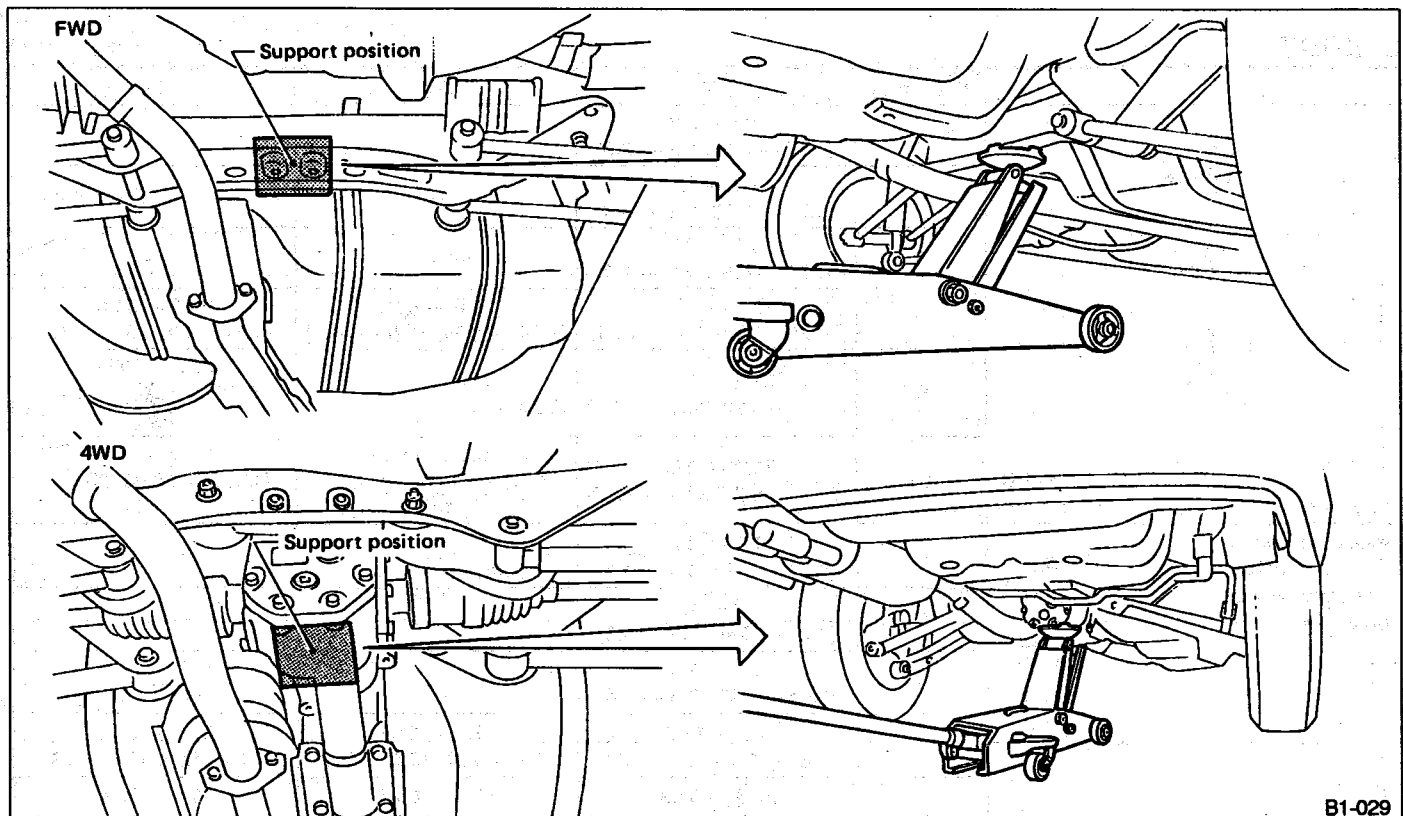
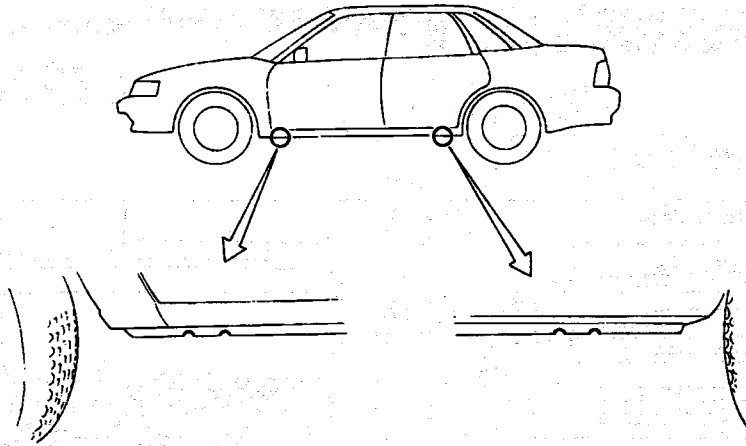


Fig. 33 Rear

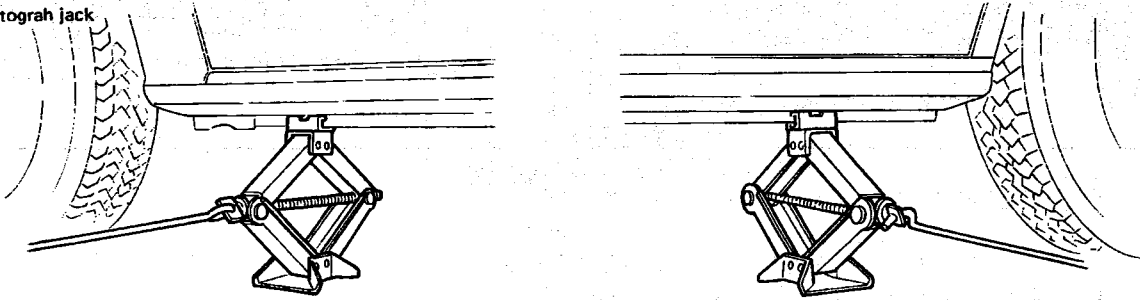
- a. Never get under the vehicle while it is supported by a jack.
- b. When jacking up the vehicle, place chocks to hold wheels.
- c. After jacking up the vehicle with garage jack, be sure to support the vehicle with stands for safety.
- d. Be sure to lift vehicle at the same four positions as those of pantograph jack.

PANTOGRAPH JACK, SAFETY STAND AND LIFT

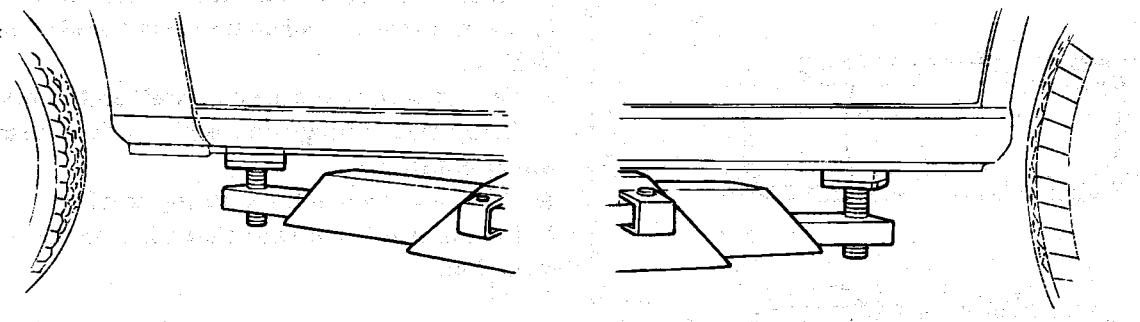
Support locations



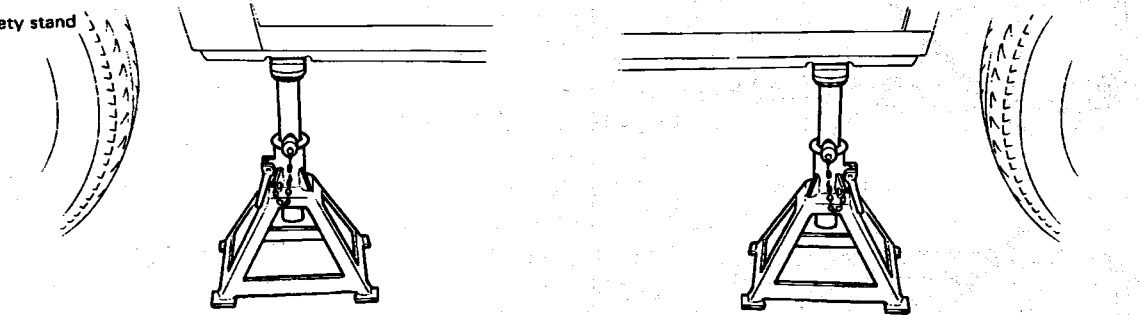
Pantograph jack



Lift



Safety stand



B1-028

-029

- a. Never get under the vehicle while it is supported only by the jack. Always use safety stands to support body when you have to get under the car.
- b. Block the wheels diagonally by wheel chocks.
- c. Make sure the jack is set at the correct position on the flange of side still.
- d. Be careful not to set the jack at the air flap portion.

3. TOWING AND TIE-DOWN HOOKS

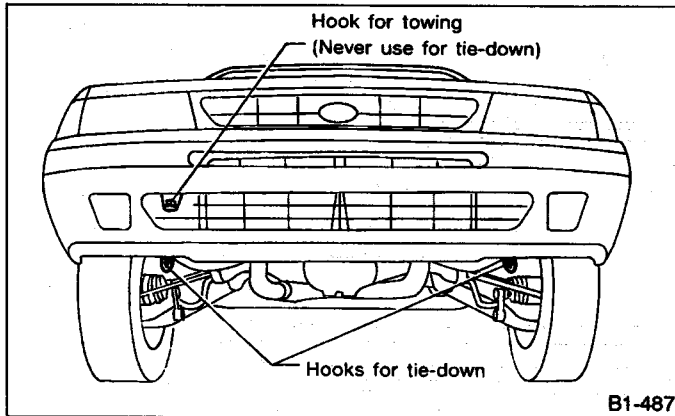


Fig. 35

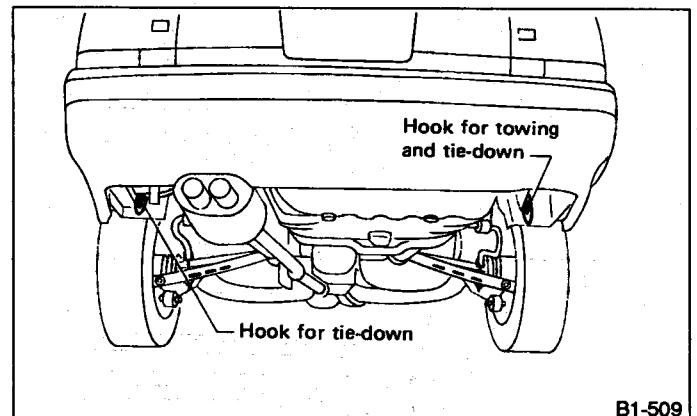


Fig. 36

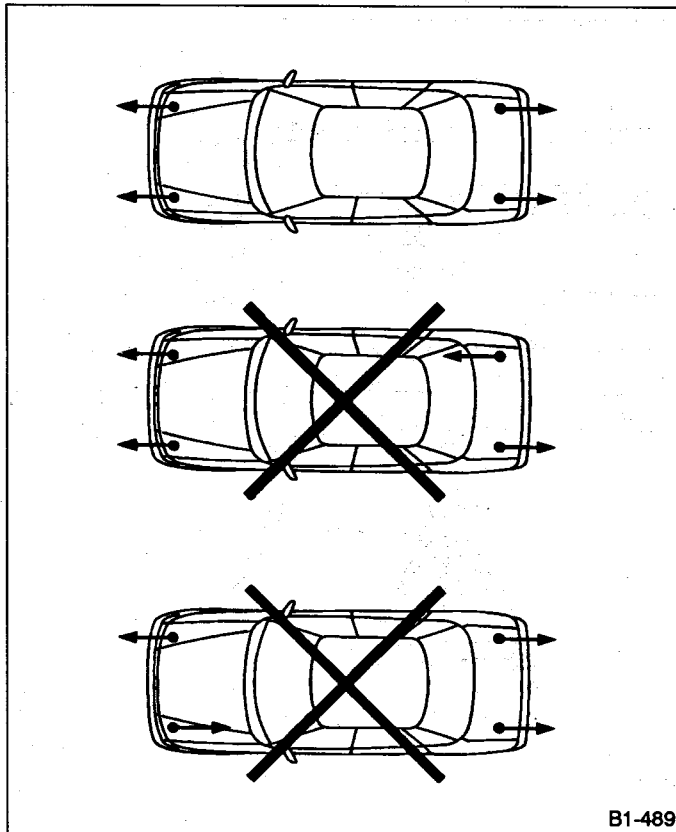


Fig. 37

- a. Avoid towing another car with front towing hooks.
- b. Do not tow a vehicle which is heavier than towing vehicle.
- c. Do not apply excessive lateral load to towing hook.
- d. Wrap the towing rope with cloth to prevent damaging bumper, etc.
- e. Keep the vehicle level during towing.
- f. Tie the front and rear tie-down hooks in the same direction.

rt body

PRE-DELIVERY INSPECTION

1-4

SUBARU®

1992

SERVICE MANUAL

1-509

books.
wing

look.
lam-

ame



	Page
1. Pre-road Test Inspection	2
A: HOOD OPERATION	2
B: DOOR OPERATION, DOOR LOCK AND REGULATOR	2
C: TRUNK LID, REAR GATE AND FUEL LID OPERATION	2
D: BRAKE FLUID LEVEL AND BRAKE PIPING INSTALLATION	2
E: BATTERY FLUID LEVEL AND BATTERY INSTALLATION	3
F: COOLANT LEVEL AND COOLING FAN INSTALLATION	3
G: ENGINE OIL LEVEL	4
H: TRANSMISSION AND DIFFERENTIAL GEAR OIL LEVEL	5
I: BELT TENSION ...Refer to 1-5 [01A0]	-
J: AIR CLEANER	6
K: JACK INSTALLATION	6
L: WINDSHIELD WASHER AND WINDSHIELD WIPERS	6
M: REAR WINDOW WASHER AND WIPER	7
N: WHEEL NUTS FOR LOOSENESS AND TIRE INFLA- TION PRESSURE	7
O: SEAT ADJUSTER AND SEAT BELTS	7
P: FUSES	7
Q: LIGHTS AND SWITCHES	7
R: PREPARATION FOR UNDERSIDE INSPECTION ...Refer to 1-3 [0602]	-
S: READ MEMORY CONNECTOR (MPFI & SPFI model)	7
T: INSTALLATION OF STEERING COMPONENTS	8
U: EXHAUST PIPE AND MUFFLER	8
V: FUEL SYSTEM FOR LEAKAGE	8
W: HEIGHT CONTROL SYSTEM	9
X: PROTECTOR	9
2. Road Test Inspection	9
A: OPERATION OF INDICATOR LIGHTS AND GAUGES	9
B: TACHOMETER, RADIO, ETC.	9
C: DRIVING TEST	10
3. Post-road Test Inspection	13
A: IGNITION TIMING ...Refer to 2-2 [02A0]	-
B: AUTOMATIC TRANSMISSION FLUID (ATF) LEVEL	13
C: POWER STEERING FLUID LEVEL	14
D: TOE	14
E: UNDERSIDE	14
F: WATER LEAKAGE	14
G: EXTERNAL APPEARANCE AND EQUIPMENT	15

1. Pre-road Test Inspection

A: HOOD OPERATION

CHECK POINTS

1. Operation of hood release and lock
2. Condition of lock
3. Fitting of hood

B: DOOR OPERATION, DOOR LOCK AND REGULATOR

CHECK POINTS

1. Door "Open-close" operation
2. Operation of door release and lock
3. Loose or damage parts
4. Regulator handle operation
5. Position of door window glass
6. Operation of power window switches
7. Power-door locking operation

C: TRUNK LID, REAR GATE AND FUEL LID OPERATION

CHECK POINTS

1. Trunk lid, rear gate and fuel lid "open-close" operation
2. Operation of trunk lid, rear gate (release and lock)
3. Fitting of trunk lid, rear gate and fuel lid
4. Operation of trunk lid opener cancel lever

D: BRAKE FLUID LEVEL AND BRAKE PIPING INSTALLATION

CHECK POINTS

1. Fluid level in brake reserve tank
2. Wiring of fluid leveller and its operation
3. Brake booster, master cylinder, hill holder and pressure control valve for proper installation; brake pipe, brake hose and connectors for proper fitting
4. Leakage in any of the above

- Check fluid leveller operation while pushing it down with a screwdriver.

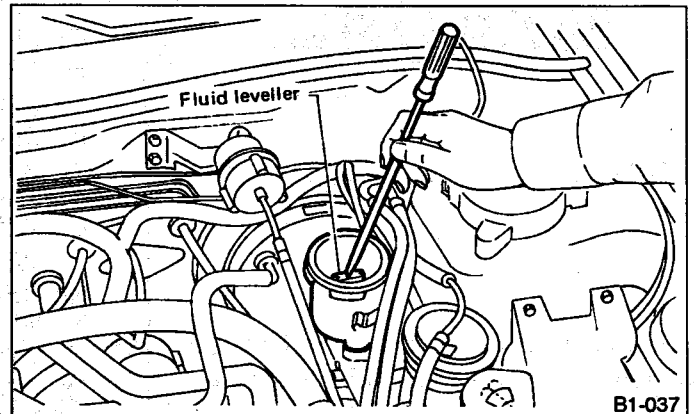


Fig. 1

Recommended brake fluid

FMVSS No. 116, fresh DOT3 or DOT4 brake fluid

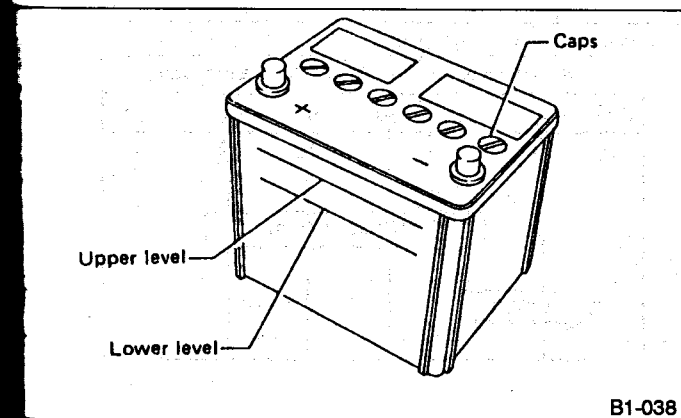
- a. The fluid level must be kept at "MAX" level.
- b. Do not mix different brands of brake fluid.
- c. When adding brake fluid, be careful not to allow any dirt, water, or oil around the fluid tank to enter it.
- d. Never use engine oil, gear oil, or any mineral oil.
- e. Use extreme care not to allow any water to get into the fluid; water in the brake fluid will lower the fluid's boiling point and cause vapor-lock.
- f. Use special care not to spill any brake fluid on the vehicle's painted surfaces, because it will quickly erode them. In case of an accident, wipe it off as quickly and as cleanly as possible.
- g. If too much brake fluid is missing, check the brake line for possible leakage.
- h. After adding brake fluid, any excess must be stored in a tightly sealed container.
- i. When checking the operation of leveller, use clean screwdriver or the like and be careful not to allow dirt or dust to get into the tank.

E: BATTERY FLUID LEVEL AND BATTERY INSTALLATION

CHECK POINTS

1. External parts
2. Electrolyte level
3. Specific gravity

1. Check for the existence of dirt or cracks on the battery case, top cover, vent plugs, and terminal posts. If necessary, clean with water and wipe with a dry cloth. Apply a thin coat of grease on the terminal posts to prevent corrosion.
2. Check the electrolyte level in each cell. If the level is below MIN LEVEL, bring the level to MAX LEVEL by pouring distilled water into the battery cell. Do not fill beyond MAX LEVEL.



B1-038

Fig. 2

Electrolyte has toxicity; be careful handling the acid.

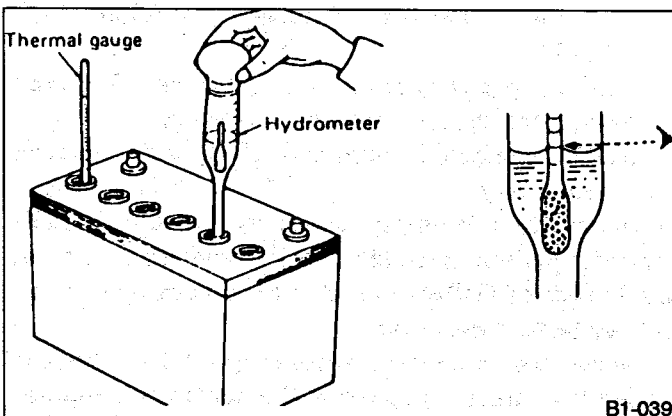
Avoid contact with skin, eyes or clothing. Especially contact with eyes, flush with water for 15 minutes and get prompt medical attention.

Batteries produce explosive gasses. Keep sparks, flames, cigarettes away.

Ventilate when charging or using in enclosed space.

The specific gravity of electrolyte can be measured with a hydrometer. Holding the glass tube vertically, slowly draw the liquid into the tube. Take the reading on the float scale at the highest point of the liquid.

When reading, the eye should be level with the surface of the liquid.



B1-039

Fig. 3

Serviceable specific gravity

1.220 — 1.280 at 20°C (68°F)

If the specific gravity reading is below 1.220 at 20°C (68°F), the battery must be recharged and, if necessary, the specific gravity of the electrolyte must be adjusted. The specific gravity changes according to temperature. The standard temperature is considered to be 20°C (68°F).

When measuring the specific gravity, calculate as follows:

$$S = St + 0.0007 (t - 20)$$

S = Specific gravity corrected for 20°C (68°F)

St = Measured specific gravity at t°C

t = Electrolyte temperature on centigrade scale (°C)

0.0007 = Temperature coefficient

[EXAMPLE]

A hydrometer reading of 1.273 at 30°C (86°F) is corrected to 1.280 at 20°C (68°F), indicating that the battery is fully charged. On the other hand, a reading of 1.251 at -10°C (14°F) is corrected to 1.230 at 20°C (68°F), indicating that the battery is partially charged.

F: COOLANT LEVEL AND COOLING FAN INSTALLATION

CHECK POINTS

1. Coolant level
2. Cooling fan motor and wiring
3. Water leakage and hose damage

a. Always inspect and add at reserve tank when engine is cold.

b. The level must be kept at "FULL" level.

- c. Use only genuine SUBARU Coolant (P/N000016218).
- d. Avoid using any coolant or only water other than this designated type to prevent corrosion.
- e. SUBARU's engine is aluminum alloy, and so special care is necessary.
- f. If reserve tank is empty, check coolant level in radiator. Add coolant up to filler neck of radiator, if necessary. In case of TURBO model, add coolant up to coolant filler tank, if necessary.
- g. The radiator is a high pressure type. Never attempt to open the radiator cap when the coolant's temperature is high; otherwise boiling water will spurt out. Be sure to wait until the engine cools down before opening the radiator cap.
- h. When retightening the hose clamps, be careful not to over-tighten them, as doing so could damage the hose.

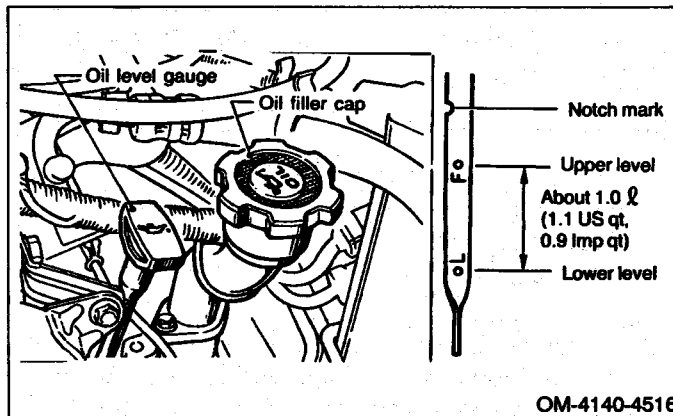


Fig. 5

- Recommended oil

API classification: SF or SG

G: ENGINE OIL LEVEL

CHECK POINTS

1. Engine oil level

- The level should be within the specified range marked on the gauge.
- a. Check engine oil level before starting the engine, when engine oil is cold, to obtain correct level reading. After stopping a hot engine, wait about 5 minutes until oil returns to oil pan before checking oil level. Oil level reading will be slightly higher than when engine is cold due to oil expansion. It is advisable to check oil level each time oil is replenished.
- b. Insert the oil level gauge into guide hole in proper direction as figure.

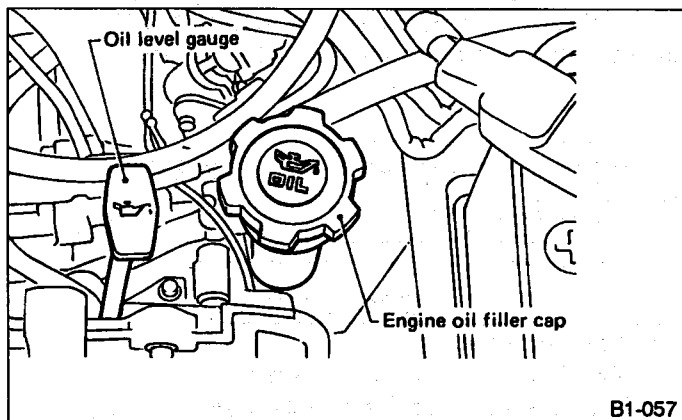


Fig. 4

• MPFI and SPFI and TURBO

SAE viscosity No. and Applicable Temperature					
(°F)	-30	0	30	60	90
(°C)	-34	-18	0	16	32
	10W-30, 10W-40				
	← 5W-30				

• CARBURETOR

SAE viscosity No. and Applicable Temperature					
(°F)	-30	0	30	60	90
(°C)	-34	-18	0	16	32
	10W-30, 10W-40				
	← 5W-30				

B1-510

Fig. 6

- a. When replenishing oil, it does not matter if the oil to be added is a different brand from that in the engine, however, use oil having the API classification and SAE viscosity No. designated by SUBARU.
- b. SAE 5W-30 is not recommended for sustained high speed driving.

H: TRANSMISSION AND DIFFERENTIAL GEAR OIL LEVEL

CHECK POINTS

1. Level of transmission gear oil for manual transmission
2. Level of differential gear oil for automatic transmission
3. Level of rear differential gear oil for 4WD model.

The level should be within the specified range marked on the gauge.

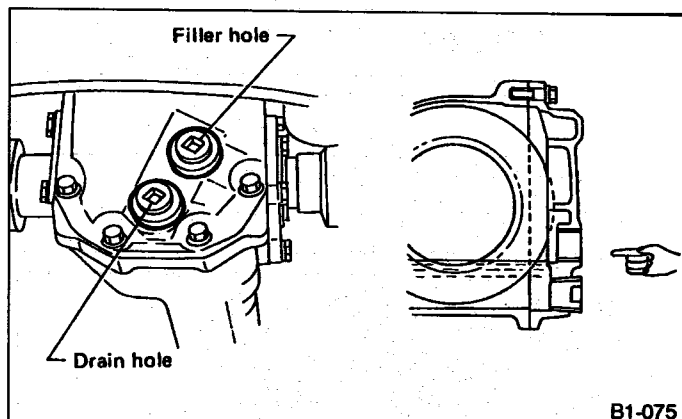
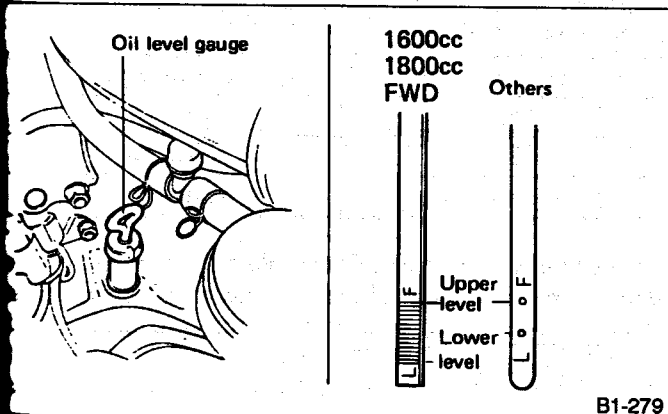


Fig. 9 4WD rear differential

- Recommended oil



B1-279

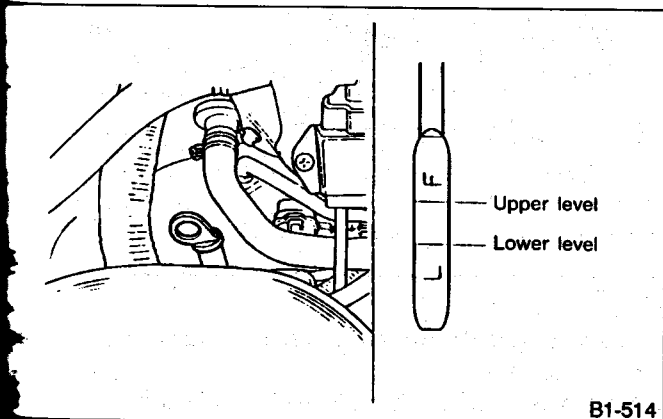
Fig. 7 Manual transmission

ITEM	API Classification	SAE Viscosity No. and Applicable Temperature				
		(°F) -30	0	30	60	90
<ul style="list-style-type: none"> ● Transmission and differential gear oil ● 4WD rear differential gear oil 	GL-5	(°C) -34	-18	0	16	32

Fig. 10

- a. Each manufacturer uses different base oils and additives. Thus, do not mix brands.
- b. *For differential gear oil (AT)

B1-041



B1-514

Fig. 8 Differential for automatic transmission (4AT)

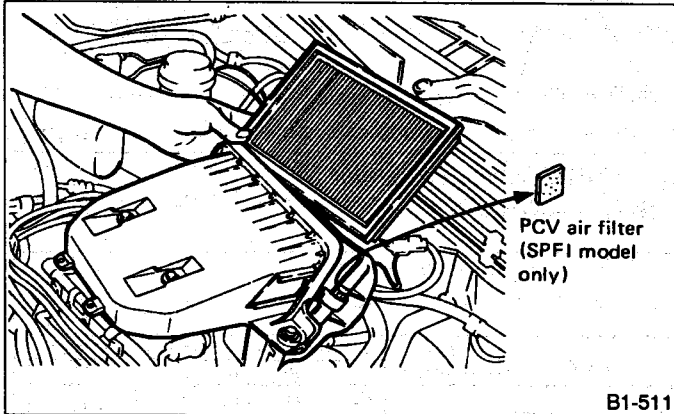
When inserting the level gauge into differential for automatic transmission, align the protrusion on the top part of the level gauge with the notch of the gauge hole.

Insert a finger into the filler port to determine whether the oil is level with the port opening.

J: AIR CLEANER

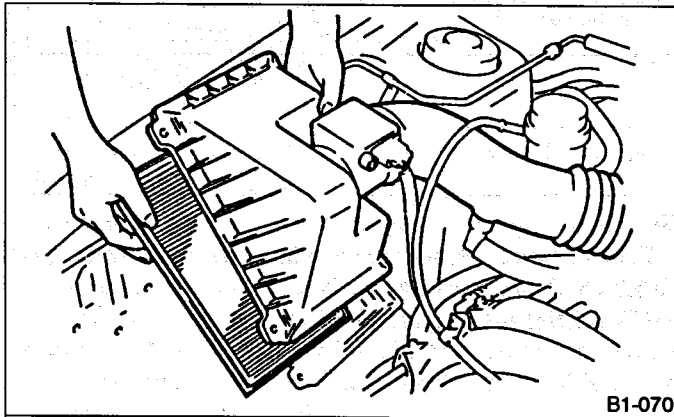
CHECK POINTS

1. Contamination of air cleaner element
2. Related parts



B1-511

Fig. 11 1800 cc and 1600 cc



B1-070

Fig. 12 2200 cc and 2000 cc

- a. The air cleaner element is a viscous type, which should not be washed or cleaned.
- b. If the air cleaner element is broken or damaged, replace it with a new one.

K: JACK INSTALLATION

CHECK POINTS

1. Installed condition of jack

L: WINDSHIELD WASHER AND WINDSHIELD WIPERS

CHECK POINTS

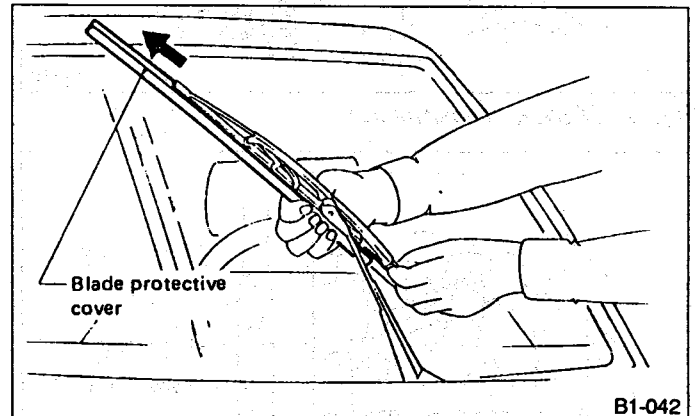
1. Installation of windshield washer tank
2. Checking of fluid level
3. Direction and quantity of windshield washer fluid sprayed
4. Operation of windshield wiper and washer

- In areas where water freezes in winter, use SUBARU windshield washer fluid (003406401) or an equivalent.

The relationship between fluid to water ratio and freezing point is as follows:

Fluid to water ratio (%)	Freezing point °C (°F)
30	-12 (10)
50	-20 (-4)
100	-45 (-49)

- a. Before checking the windshield wiper, remove the blade protective cover and clean the windshield glass.



B1-042

Fig. 13

- b. Do not operate the windshield wiper when the reservoir is empty.
- c. Before operating the windshield wipers, be sure to eject windshield washer fluid onto the windshield. If the windshield is dry, the wipers' operating speed and angle of operation will be different from when it is wet.
- d. If the position at which washer fluid is ejected is wrong: Using an eyelet or similar tool, adjust the direction of the nozzle, be careful not to damage the nozzle hole.
- e. Do not operate the windshield washer continuously for more than 10 seconds at a time.

M: REAR WINDOW WASHER AND WIPER

CHECK POINTS

1. Quantity of washer fluid
2. Direction and quantity of washer fluid sprayed
3. Operation of rear window washer and wiper

N: WHEEL NUTS FOR LOOSENESS AND TIRE INFLATION PRESSURE

CHECK POINTS

1. Wheel nut tightening torque
2. Tire inflation pressure and tire specification
3. Damage to tire and rim

Tightening torque:

78 — 98 N·m (8.0 — 10.0 kg-m, 58 — 72 ft-lb)

- a. When checking the wheel nuts, be sure to use a torque wrench, and tighten the nuts to the specified torque.
- a. After inspecting and adjusting the tire pressure, be sure to put the valve cap back.

O: SEAT ADJUSTER AND SEAT BELTS

CHECK POINTS

1. Front and rear seats, and their facing materials
2. Front seat operation
3. Rear seat folding operation
4. Seat belts and their fit

P: FUSES

CHECK POINTS

1. Fuse installation
2. Spare fuse

Use as shown in the figure is disconnected to avoid recharging the battery.
 Insert fuse (10A) in the main fuse box inside the engine compartment. Use spare fuse shown by arrow.

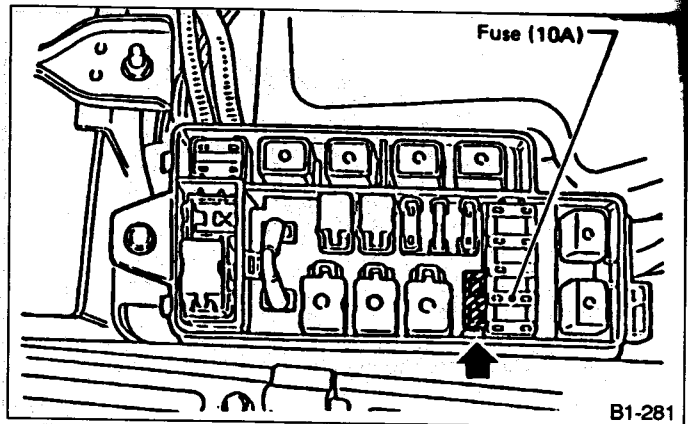


Fig. 14

Q: LIGHTS AND SWITCHES

CHECK POINTS

1. Visual inspection of lights (installation, damage, dirty lenses, water inside, etc.)
2. Operation of all lights and switches
3. Horn operation
4. Operation of heater and ventilator

S: READ MEMORY CONNECTOR (MPFI & SPFI model)

CHECK POINTS

1. Check engine light flashing.
2. Read memory connector disconnection.

- Check the check engine light flashing.
 - a. With the read memory connector connected, set the ignition switch to ON (with engine OFF and ON). Flashing of the check engine light indicates no trouble.
 - b. If the check engine light displays a trouble code when the ignition switch is set to ON (with engine OFF), or if the check engine light illuminates with engine ON, this indicates that a trouble has occurred. Check Troubleshooting. Refer to 2-7: FUEL INJECTION SYSTEM.
 - c. If engine fails to turn over when the ignition switch is set to START, check the spark plugs. Refer to 6-1: Spark Plug [W4A0].
- Check the read memory connector disconnection.
 - a. Disconnect the read memory connector after checking that there is no trouble in the engine.

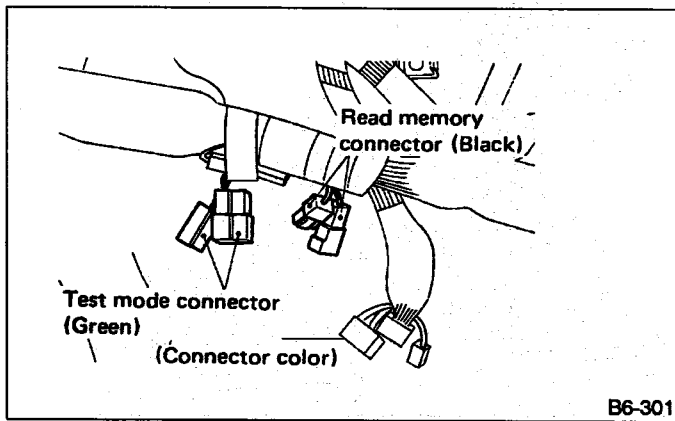


Fig. 15

T: INSTALLATION OF STEERING COMPONENTS

CHECK POINTS

1. Installation of universal joints
2. Steering gear box for looseness, play, or backlash, and boots for damage
3. Tie-rod and tie-rod end for proper installation, or damage

1) Check the universal joint for looseness.

When checking, turn ignition switch to "ACC" position.

Tightening torque:

21 — 26 N·m (2.1 — 2.7 kg-m, 15 — 20 ft-lb)

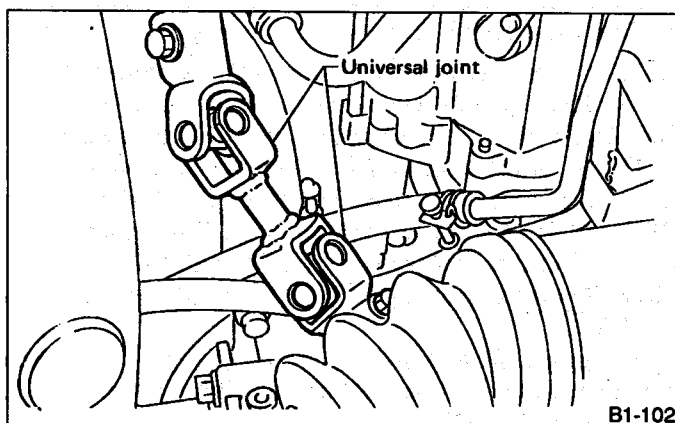


Fig. 16

2) Check the gear box mounting bolt for looseness.

Tightening torque:

47 — 71 N·m (4.8 — 7.2 kg-m, 35 — 52 ft-lb)

3) Check the tie-rod end lock nut for looseness.

Tightening torque:

78 — 88 N·m (8.0 — 9.0 kg-m, 58 — 65 ft-lb)

4) Carefully check the root portion of the boots, and the condition of the clips.

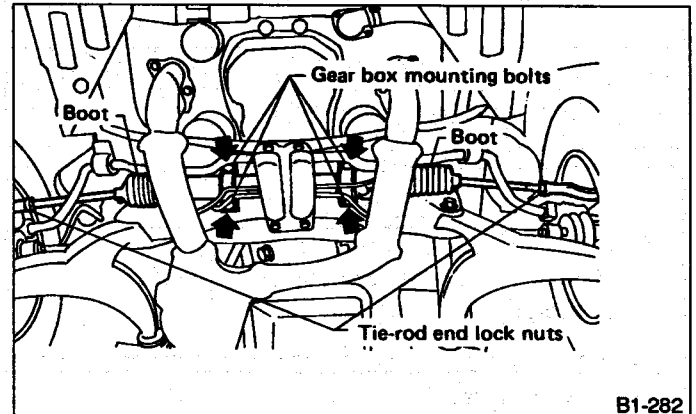


Fig. 17

U: EXHAUST PIPE AND MUFFLER

CHECK POINTS

1. Exhaust system's installation
2. Exhaust gas leakage

1) Check the exhaust system's installation for looseness, damage and possible interference with other parts. (Refer to Chapter 2-9 for tightening torque.)

When the engine is running, and for a short time after it is stopped, the exhaust system remains very hot; use extreme care and don't get burnt during this evolution.

V: FUEL SYSTEM FOR LEAKAGE

CHECK POINTS

1. Installation of fuel hose and pipe. And condition of clamps
2. Fuel system for leakage

1) Check the fuel hose's layout, and also search for interference with other parts, twists, or damage, check the condition of the clamps.

Check the fuel and air breather pipes visually or by feeling with your fingers from the underside. Retighten the clamps if necessary.

- a. When retightening the clamps, do not tighten them excessively
 - b. When checking the fuel system, use extreme care to prevent accidental fires.
- 2) Without starting the engine, turn the ignition switch to the ON position, and operate the fuel pump to pressurize the fuel system. Then check the fuel system for leakage.

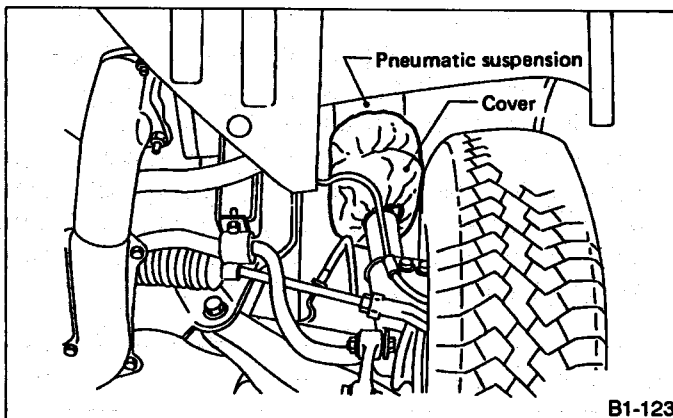


Fig. 18

Label of rear differential is covered by tape. Remove it.

2. Road Test Inspection

A: OPERATION OF INDICATOR LIGHTS AND GAUGES

- CHECK POINTS**
1. Operation of indicator lights
 2. Operation of gauges

Check the operation according to the "Owner's manual".

- a. Perform this inspection with the gear shift lever in the neutral position.
(For automatic transmission models: Set the select lever in the "P" position.)
- b. Set the parking brake.
- c. Do not race the engine excessively.

B: TACHOMETER, RADIO, ETC.

- CHECK POINTS**
1. Operation of tachometer, radio, cigarette lighter, etc.

- Tachometer
Race the engine two or three times, and check the tachometer's operation.

Do not race the engine more than necessary.

- Radio
Check the operation according to the "Owner's manual".

- Cigarette lighter
To operate, push in the knob completely and wait for a moment. The lighter will click out of holder automatically when ready to use.

W: HEIGHT CONTROL SYSTEMAir (Pneumatic) Suspension Vehicle

- CHECK POINTS**
1. Function of height control changeover

- Check the function of height control changeover.
 - 1) Unload the car to establish "curb weight" condition.
 - 2) Start engine and operate height control switch to "NORMAL".

Ensure ground clearance is automatically set to the NORMAL value as indicated in Chapter 4-1.

- 3) Check air suspension compressor to ensure it stops. If it still is in operation, wait until it stops.

The above procedure is required to determine whether or not, car height control is in good order and should not be omitted.

- 4) After compressor stops, set height control switch to "HIGH" and check the following:
 - a) Check if car attains the specified height within 80 seconds.
 - b) Check if the HIGH pilot lamp is on.
 - c) Check if compressor stops within five minutes after setting height control switch to "HIGH".
- 5) Set height control switch to "NORMAL" after compressor has stopped. Check if car returns to the specified NORMAL position within one minute.
- 6) If abnormality is noted in steps 1) through 5) above, refer to Chapter 4-1 and repair as necessary.

X: PROTECTOR

- CHECK POINTS**
1. Protector removal

The following parts are covered to prevent splashing of wax. Remove protector.

CAUTION:

- a. To avoid the possibility of being burned, do not hold the cigarette lighter in by hand. This may also cause damage to the lighter heating element.
- b. When replacing the knob, it is recommended that you use only a genuine part. If you use either non-genuine parts or any combination of parts different from original knob-and-socket combination, it may cause overheating due to a short circuit.

C: DRIVING TEST**CHECK POINTS**

1. Operation of foot brake and parking brake
2. Inspect the clutch free play.
3. Operation of hill holder (Manual transmission model only)
4. Operation of clutch and gear shift
5. Operation of selector lever (Automatic transmission models only)
6. Operation of 4WD selector lever and switch (4WD models only)
7. Operation of steering and position of steering wheel
8. Operation of turn signal cancel cam
9. Operation of ventilation system and heater
10. Operation of air conditioner
11. Abnormal noises or vibration
12. Function of automatic vehicle height resumption Air (pneumatic) suspension vehicle
13. Operation of cruise control

1. Check the foot and parking brakes' operation.

1) Drive on a dry, level, paved road, and apply normal braking. Look for uneven or improper operation, or pulling to one side.

Be sure to perform this test in a safe area.

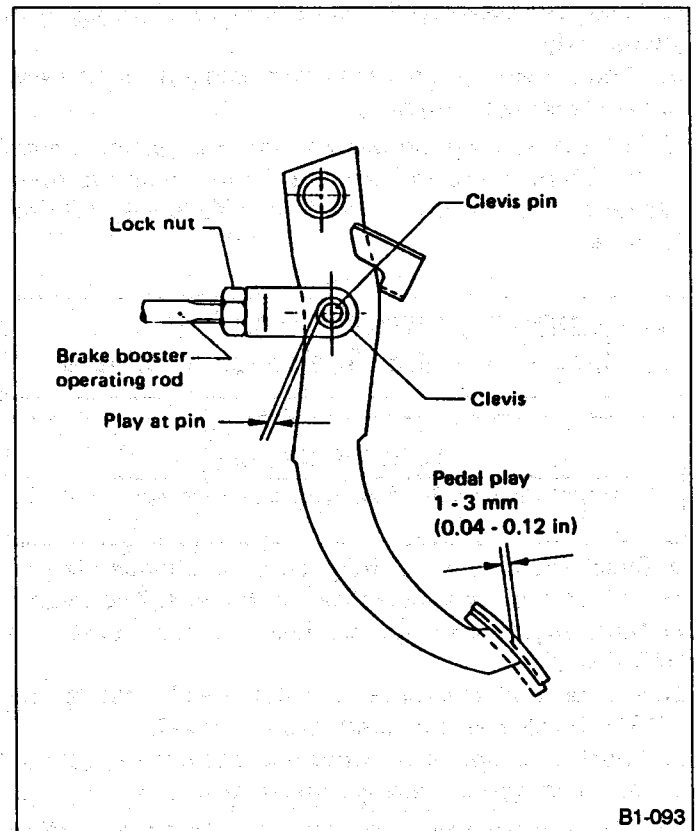
2) Press the brake pedal in two or three times, and keep it fully depressed. Make sure that the brake can be kept that way for at least five seconds. Also check for air in the brake system, or brake fluid leakage.

3) Perform the adjustment of operating rod ASSY as follows:

(1) Be sure engine is off. (No vacuum is applied to brake booster).

(2) There should be play between brake booster clevis and pin at brake pedal installing portion.

[Depress brake pedal pad with a force of less than 10 N (1 kg, 2 lb) to a stroke of 1 to 3 mm (0.04 to 0.12 in).]



B1-093

Fig. 19

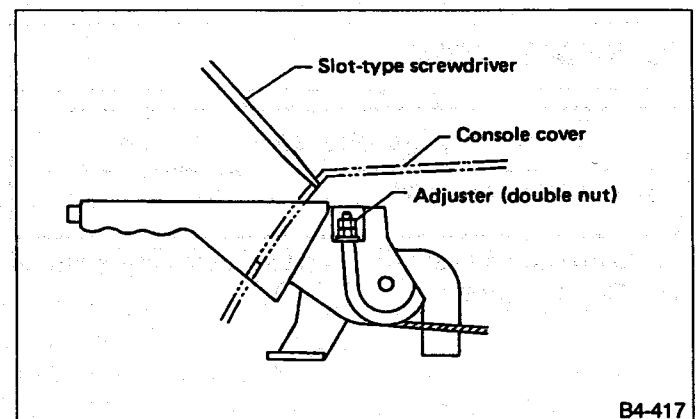
(3) Depress the surface of brake pad by hand.

(4) If there is no free play between clevis pin and clevis, loosen lock nut for operating rod and adjust operating rod by turning in the direction that shortens it.

(5) After adjustment, make sure there is no brake dragging.

4) Pull the parking brake lever completely out, and check its operation. Also check the ratchet for normal functioning.

Check the parking brake lever stroke. If it is out of specification, adjust it by turning adjusting nut at parking brake lever.



B4-417

Fig. 20

Parking brake lever stroke:

Standard

7 — 8 notches/196 N (20 kg, 44 lb)

Tightening torque (Adjusting nut):

5.4 — 9.3 N·m (0.55 — 0.95 kg·m, 4.0 — 6.9 ft·lb)

2. Inspect the clutch pedal free play.

1) Mechanical application type

(1) Lightly press the clutch pedal down with a finger to check the free play.

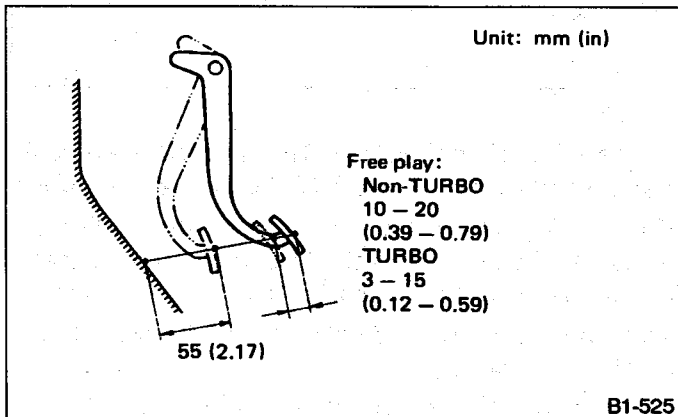


Fig. 21

(2) If it is out of specification, adjust it by turning adjusting nut on engine side end of clutch cable at release fork.

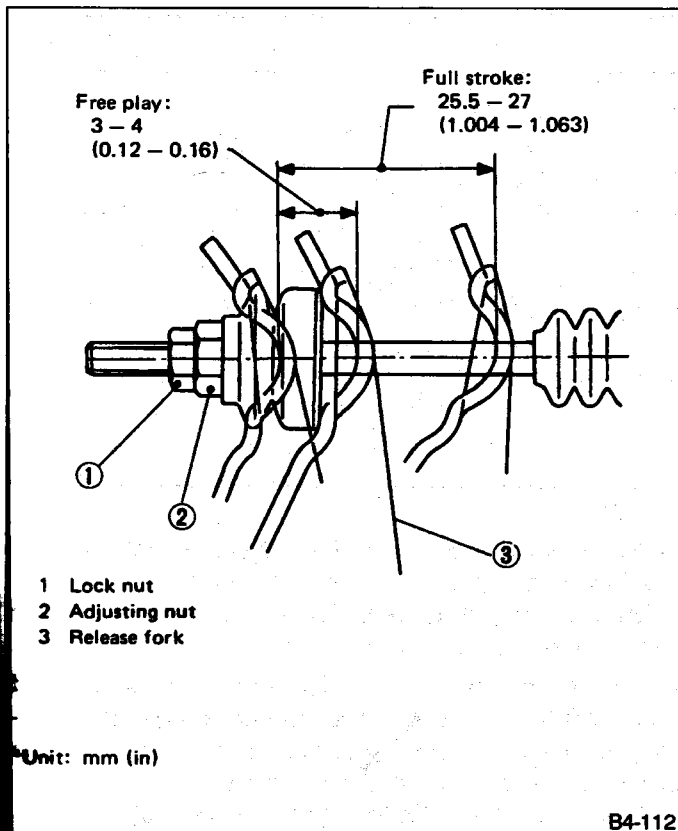


Fig. 22

2) Hydraulic application type

- (1) Lightly press the clutch pedal down with a finger to check the free play.
- (2) If it is out of specification, loosen lock nut for push rod and adjust push rod by turning in the direction that shortens or lengthens it.

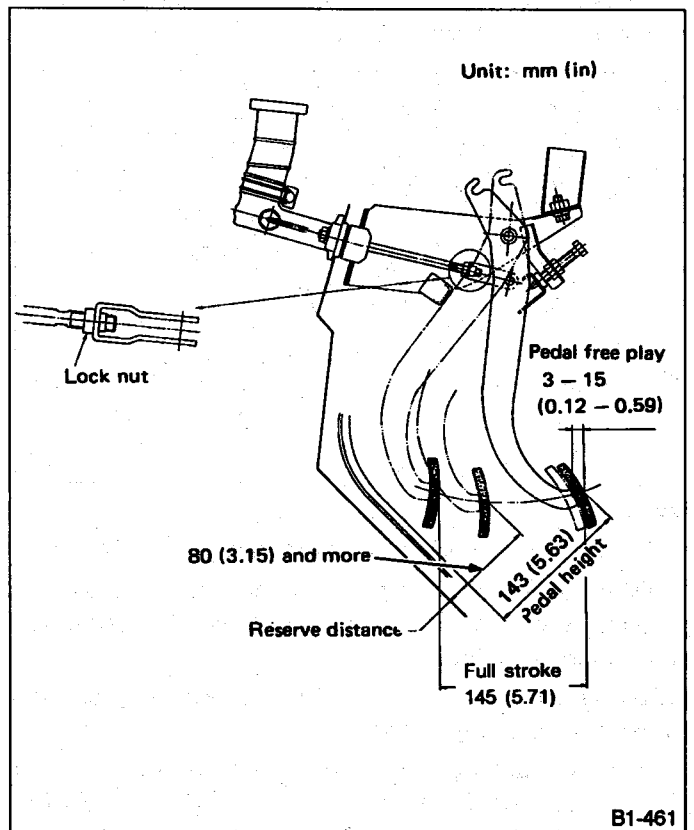


Fig. 23

Tightening torque (Adjusting nut):

9 — 11 N·m (0.9 — 1.1 kg·m, 6.5 — 8.0 ft·lb)

(3) Check the fluid level on the outside of the clutch master cylinder tank. If the level is below "MIN", add clutch fluid to bring it up to "MAX".

Recommended clutch fluid:

FMVSS No. 116, fresh DOT 3 or DOT 4 brake fluid

3. Check the hill holder operation.

1) Confirm stopping and starting performances by activating hill holder on an uphill road of 3° or higher inclination.

- If the vehicle does not stop, tighten adjusting nut of pressure holding valve (PHV) cable.

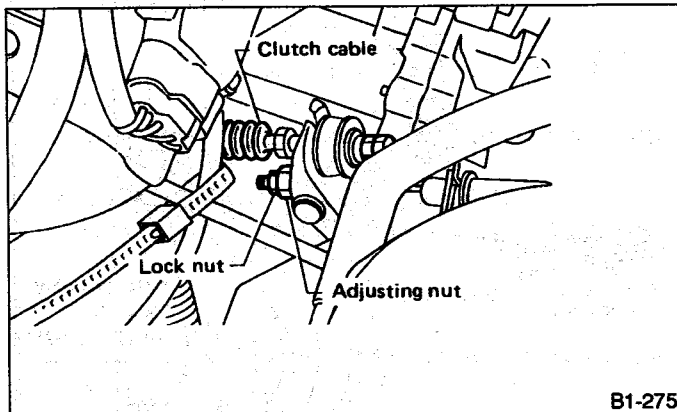
- If the vehicle does not start properly, it should be corrected by following case A or case B.

Case A: When the hill holder releases after the clutch pedal is engaged (the engine tends to stall), loosen the adjusting nut gradually until smooth starting is possible.

Case B: When the hill holder releases before the clutch pedal engages (the vehicle slips down slightly), tighten the adjusting nut so that the hill holder releases after the clutch pedal engages (case A).

Then make adjustment as in case A.

Whenever turning adjusting nut, hold inner cable with pliers so that it does not rotate.



B1-275

Fig. 24

4. Check the operation of clutch and gear shifting.

- 1) With the engine idling and the shift lever in neutral, gradually depress the clutch pedal, to see if it generates any abnormal noise.

Carefully compare a normal clutch's operating sounds to the clutch being tested.

- 2) Pull the parking brake lever completely out, and place wheel chocks under the tires. Then depress the clutch pedal completely, and place the shift lever in 4th speed.

Raise engine rpms a little, gradually engage the clutch, and see if the engine stalls.

If the engine stalls, it means that the clutch is not slipping.

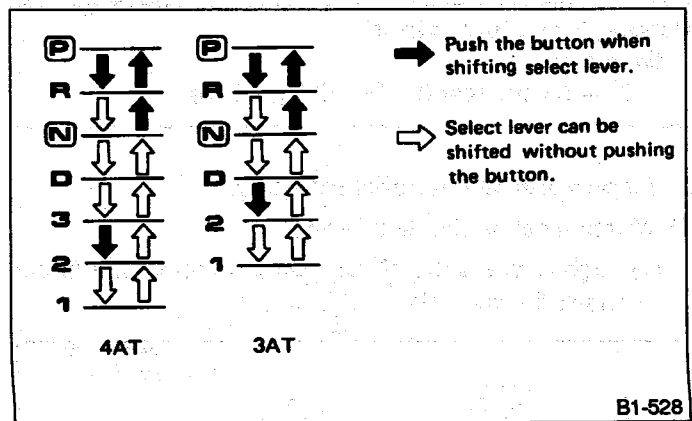
- a. Be sure to perform this test in a safe area.
- b. Do not repeat this test.

- 3) Remove the wheel chocks, and return the shift lever to neutral, then check the gear shifting mechanism for excessive play.

- 4) Drive the car at various speeds. While depressing the clutch pedal completely, move the gear shift lever into each position, and check for any unusual play or unusual resistance.

5. Operation of selector lever (Automatic transmission models only)

- 1) Place the selector lever in each position, and make sure that the pointer indicates the position of each range correctly.



B1-528

Fig. 25

6. Operation of 4WD drive selector (4WD dual-range models) and Selector switch (Selective 4WD models)

While driving, check the operation of the 4WD drive selector and selector switch. Also check that indicator light on instrument panel comes on.

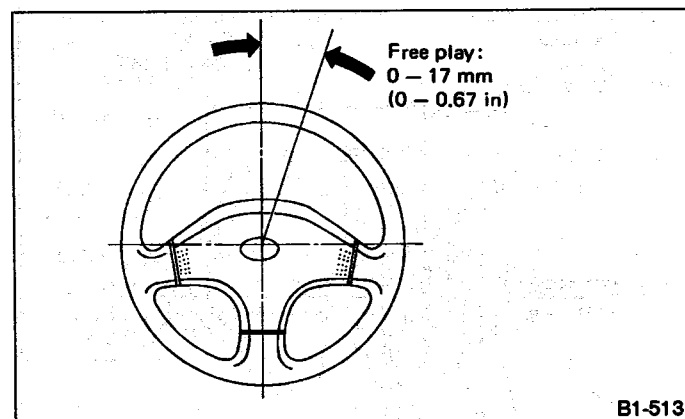
Never shift the drive selector while the wheels are spinning or slipping.

7. Operation of steering and position of steering wheel

- 1) Check the steering wheel for free play.

Steering wheel free play:

0 — 17 mm (0 — 0.67 in)



B1-513

Fig. 26

- 2) With the car moving straight ahead, check for hard steering, shimmy, or other abnormalities.

- 3) Make a turn, and check for hard or heavy steering wheel operation, or poor stability.

8. Make a right or left turn with the turn signal on, and make sure that the turn signal switch returns automatically to the OFF position when the steering wheel is returned to the straight ahead position.

9. Operation of ventilation system and heater

- 1) While driving, move the control lever and dial into each position, and check the ventilation system's operation. Also check for unusual vibration or noises.

2) Move the temperature control lever and fan switch, and make sure that warm air is discharged into the compartment.

10. Operation of air conditioner

Turn the air-conditioner switch "ON", and make sure that cool air is discharged into the compartment.

11. Abnormal noises or vibration

1) When starting the engine, and while driving the vehicle, check the engine, transmission, body, suspension, and steering system for any unusual noises or vibration.

Do this when idling the engine, accelerating, decelerating, and running at low, middle and high speeds.

2) Depress the accelerator pedal, and make sure that the engine rpms increase smoothly and that the vehicle accelerates smoothly.

3) While driving, turn the steering wheel right and left to test the vehicle's stability and response.

Be sure to perform this test in a safe area.

12. Check the function of automatic vehicle height resumption.

(1) Move height control switch to "HIGH" while operating car below 70 km (43 mile)/h to see if HIGH pilot lamp comes on.

(2) Operate car at speed higher than 90 km (56 mile)/h for at least five seconds to check if NORMAL pilot lamp instead of HIGH pilot lamp comes on.

(3) Operate car at speed lower than 56 km (35 mile)/h for at least five seconds to check if HIGH pilot lamp instead of "NORMAL" pilot lamp comes on again.

(4) Stop car and move height control switch to "NORMAL". Check if car is set to the NORMAL height position.

(5) If abnormality is noted in steps (1) through (4) above, refer to Chapter 4-1 and repair as necessary.

Be sure to conduct driving tests using a chassis dynamometer with front wheels set in operation, or test on an authorized race course or similar place.

13. Check the operation of the cruise control according to the "Owner's Manual" or "Instruction Manual".

3. Post-road Test Inspection

B: AUTOMATIC TRANSMISSION FLUID (ATF) LEVEL

CHECK POINTS

- Level of ATF

The ATF should be maintained at the proper level as follows:

- 1) Drive the car several miles to bring the transmission to the normal operating temperature. 60 to 80°C (140 to 176°F) is normal.
- 2) Park the car on a level surface.
- 3) While idling the engine, shift select lever to all positions. Then return it to "P".
- 4) Remove the level gauge and wipe it clean.
- 5) Reinsert the level gauge completely.
- 6) Remove it again and note its reading.

If the fluid level is at the lower mark or below on the "HOT" side, add the recommended automatic transmission fluid to bring the level to the high mark. ATF is added through the level gauge hole. When the fluid level has to be checked without time to warm up the automatic transmission, check to see that the fluid level is within the marks on the "COLD" side. If it is below the marks, add fluid.

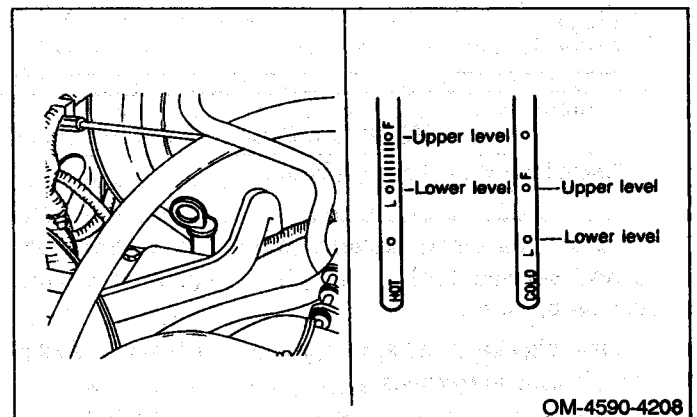


Fig. 27 4AT

Do not fill above the high mark level.

OM-4590-4208

C: POWER STEERING FLUID LEVEL**CHECK POINTS**

- Level of power steering fluid

The power steering fluid should be maintained at a proper level.

Check level as follows:

- 1) Drive the car several miles or kilometers to bring power steering system up to the normal operating temperature of about 60°C (140°F).
- 2) Park the car on a level surface and stop the engine.
- 3) Remove the level gauge and wipe it clean.
- 4) Reinstall the level gauge firmly.
- 5) Remove it again and read the level on the "HOT" side.

If the fluid level is at the lower level or below it, add recommended power steering fluid up to the high level. When the fluid level is to be checked without warming up the power steering system [at approximately 21°C (70°F)], read the fluid level at the "COLD" position of the level gauge.

- a. The available power steering fluid is ATF DEXRON II. Be sure to use the recommended fluid.
- b. When power steering fluid is added, be careful not to allow any dust into the tank.

D: TOE**CHECK POINTS**

- Toe of front and rear wheels

1) To check the toe, make sure that the spare tire, floor mats and service tool are in place. No other weight should be present.

a. Before checking wheel alignment with a sideslip tester, check the following:

- (1) Left and right tires are the same type and size.
- (2) Tires are inflated to specified pressure.

b. When driving over the sideslip tester, be sure to drive the vehicle slowly with the steering wheel fixed in the straight ahead position.

2) If the measured toe or sideslip value is not within the standard range, refer to Chapter 4-1 and adjust them.

E: UNDERSIDE**CHECK POINTS**

1. Leakage of engine oil, transmission gear oil, differential gear oil, etc.
2. Leakage of coolant
3. Leakage of brake fluid
4. Loose suspension mountings or steering mounting

Raise the vehicle body and perform these checks from the underside.

- 1) Visually check for any signs of engine oil, transmission gear oil, differential gear oil, etc. leakage.
- 2) Visually check for any sign of coolant leakage.
- 3) Visually check for any sign of brake fluid leakage.
- 4) Check the suspension mounting and steering mounting for any loose or unconnected parts.

F: WATER LEAKAGE**CHECK POINTS**

- Water leakage by pouring water

1) Before performing the water leakage test, remove anything that may obstruct the operation or which must be kept dry.

2) Close all of the windows completely, and then close all of the doors tightly. Close the hood and trunk lid before starting the test.

3) Connect a hose to a tap, and spray water on the vehicle. The rate of water discharge must be approx. 20 to 25 liters (5.3 to 6.6 US gal, 4.4 to 5.5 Imp gal) per minute. When spraying water on areas adjacent to the floor and wheel house, increase the pressure.

When directing water on areas other than the floor portion and wheel house, decrease the pressure. But the force of water must be made strong occasionally by pressing the end of the hose.

Be sure to keep the hose at least 10 cm (3.9 in) from the vehicle.

4) Check the following areas:

- (1) Front window and body framework mating portion
- (2) Door mating portions
- (3) Glass mating portions
- (4) Rear quarter windows mating portions
- (5) Rear window and body framework mating portion

- (6) Trunk lid mating portion
- (7) Around roof drips

If any dampness in the compartments is discovered after the water has been applied, check all areas that may have possibly contributed to the leak carefully.

G: EXTERNAL APPEARANCE AND EQUIPMENT

CHECK POINTS

1. Paint
2. Scratches or damage to glass
3. Rust formation
4. Contamination of interior parts
5. Installation of equipment

1) Check the paint after removing the paint protective agent and washing the vehicle.

Before removing the protective agent, be sure to wash the vehicle, because the painted surface may be scratched if the surface is rubbed with sand or other hard particles which may be attached to the protective agent.

- Check the whole vehicle body for stains, flaking, damage caused by transportation, rust, dirt, cracks, or blistering.

a. It is better to determine an inspection pattern in order to avoid missing an area, since the total area is not small.

b. It is desirable not to make corrections to the body paint unless absolutely needed. However, if any corrections are required to remove scratches or rust, the area to be corrected must be limited as much as possible. Re-painting and spray painting must be avoided whenever possible.

2) Carefully check each window glass for scratches. Slight damage may be removed by polishing with cerium oxide. (Half-fill a cup with cerium oxide, and add warm water to it. Then agitate the contents until it turns to wax. Apply this wax to a soft cloth, and polish the glass.)

3) Check each portion of the vehicle body and under-side components for the formation of rust. If rust is discovered, remove it with #80 — #180 emery paper, and treat the surface with rust preventive. After this treatment is completed, flush the portion thoroughly, and prepare the surface for repair painting.

Care should be taken not to apply paint, undercoating agent, anti-corrosive wax, etc. to the following parts of air-suspension equipped models while refinishing the undercarriage.

(1) Diaphragm and rolling surfaces

(2) Air suspension compressor and dryer ASSY

- Check each portion of the body and all of the chrome parts for deformation or distortion. Also check each lamp lens for cracks.

4) Check the following interior parts for contamination.

- 1) Instrument panel and meter glass
- 2) Glove box
- 3) Sun visor
- 4) Room mirror
- 5) Assist rail
- 6) Roof trim
- 7) Door trim
- 8) Inner trim
- 9) Front and rear seats
- 10) Luggage shelf
- 11) Floor mat
- 12) Others

If the meter glass is contaminated, wipe it gently with a clean soft cloth that has been dampened with water. Do not rub the meter glass hard; otherwise, the transparent resin plate on it may become clouded due to the formation of scratches.

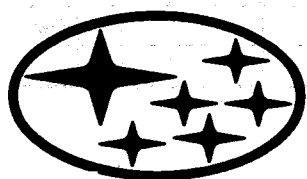
5) Check the interior and exterior equipment to make sure that they are installed securely. Also make sure that the equipment conforms to the vehicle's specifications.

Make sure that the spare tire, jack, spare key, tools, owner's manual, warranty & service booklet, etc. are all present.

SUBARU®

1992

**SERVICE
MANUAL**



SCHEDULE OF INSPECTION AND
MAINTENANCE SERVICES

	Page
SCHEDULE OF INSPECTION AND MAINTENANCE SERVICES	2
1. DRIVE BELT(S) [EXCEPT CAMSHAFT]	4
2. CAMSHAFT DRIVE BELT (TIMING BELT)	6
3. ENGINE OIL	9
4. ENGINE OIL FILTER	11
5. REPLACE ENGINE COOLANT AND INSPECT COOLING SYSTEM, HOSES AND CONNECTIONS	12
6. REPLACE FUEL FILTER AND INSPECT FUEL SYSTEM, LINES AND CONNECTIONS	16
7. AIR CLEANER ELEMENT	18
8. SPARK PLUGS	19
9. ENGINE IDLE SPEED (FOR CARBURETOR ENGINE ONLY) AND IDLE MIXTURE (NOT NECESSARY FOR CATALYTIC CONVERTER EQUIPPED VEHICLES)	20
10. TRANSMISSION/DIFFERENTIAL (FRONT AND REAR) GEAR OIL AND AUTOMATIC TRANSMISSION FLUID	22
11. BRAKE FLUID	25
12. DISC BRAKE PADS AND DISCS/FRONT AND REAR AXLE BOOTS AND AXLE SHAFT JOINT PORTIONS	27
13. BRAKE LININGS AND DRUMS	29
14. INSPECT BRAKE LINES AND CHECK OPERATION OF PARKING AND SERVICE BRAKE SYSTEM	31
15. CLUTCH AND HILL-HOLDER SYSTEM	33
16. STEERING AND SUSPENSION SYSTEM	36
17. FRONT AND REAR WHEEL BEARING LUBRICANT	42

SCHEDULE OF INSPECTION AND MAINTENANCE SERVICES

MAINTENANCE ITEM		MAINTENANCE INTERVAL (Number of months or km (miles), whichever occurs first)						REMARKS
		Months	12	24	36	48		
		x1,000 km	1.6	25	50	75	100	
		x1,000 miles	1	15	30	45	60	
1	Drive belt(s) [Except camshaft]		I	I	I	I		
2	Camshaft drive belt (Timing belt)					R		
3	Engine oil filter	Change every 12,500 km (7,500 miles) or 6 months whichever occurs first.						See NOTE 1)
4		Change every 12,500 km (7,500 miles) or 6 months whichever occurs first.						See NOTE 1)
5	Replace engine coolant and inspect cooling system, hoses and connections			P		P		
6	Replace fuel filter and inspect fuel system, line and connections			P		P	See NOTE 3)	
7	Air cleaner element		I	R	I	R	See NOTE 2)	
8	Spark plugs		R	R	R	R		
	For TURBO			R		R		
9	Engine idle speed (for carburetor engine only) and Idle mixture (not necessary for catalytic converter equipped vehicles)	I	I	I	I	I		
10	Transmission/Differential (Front & rear) gear oil and Automatic transmission fluid			R		R	See NOTE 4)	
11	Brake fluid			R		R	See NOTE 5)	
12	Disc brake pads and discs/Front and rear axle boots and axle shaft joint portions		I	I	I	I	See NOTE 3)	
13	Brake linings and drums			I		I	See NOTE 3)	
14	Inspect brake lines and check operation of parking and service brake system		P	P	P	P	See NOTE 3)	
15	Clutch and hill-holder system		I	I	I	I	Adjust pedal free play at 1,600 km (1,000 miles)	
16	Steering and suspension system		I	I	I	I	See NOTE 3)	
17	Front and rear bearing lubricant					(I)		

Symbols used:

R: Replace

I: Inspect, and then adjust, correct or replace if necessary.

P: Perform

(I) : Recommended service for safe vehicle operation

Continue periodic maintenance beyond 100,000 km (60,000 miles) or 48 months by returning to the first column of the maintenance schedule and adding 100,000 km (60,000 miles) or 48 months to the column headings.

NOTES:

- 1) When the vehicle is used under severe driving conditions mentioned below*, the engine oil and oil filter should be changed more frequently.
- 2) When the vehicle is used under severe driving conditions mentioned below*, the air filter elements should be replaced more frequently.
- 3) When the vehicle is used under severe driving conditions mentioned below*, inspection should be performed at every 12,500 km (7,500 miles) or 6 months whichever occurs first.
- 4) When the automatic transmission vehicle is frequently operated under severe conditions, such as pulling trailer or driving on sand, replacement of automatic transmission fluid and front differential gear oil should be performed more frequently.
- 5) When the vehicle is used under following areas, change fluid every 25,000 km (15,000 miles) or 12 months whichever occurs first.
 - (1) High humidity areas
 - (2) Mountainous areas

***Severe driving conditions:**

- (1) Operating in extremely cold weather (Items 3, 4 and 16 only)
- (2) Pulling trailer (Items 3, 4, 12 and 13 only)
- (3) Repeated short trips (Items 3, 4, 12 and 13 only)
- (4) Driving on dusty roads (Items 7, 12, 13 and 16 only)
- (5) Driving on rough and/or muddy roads (Items 12, 13 and 16 only)
- (6) Driving in areas using road salt or other corrosive materials (Items 6, 12, 13, 14 and 16 only)
- (7) Living in coastal areas (Items 6, 12, 13, 14 and 16 only)

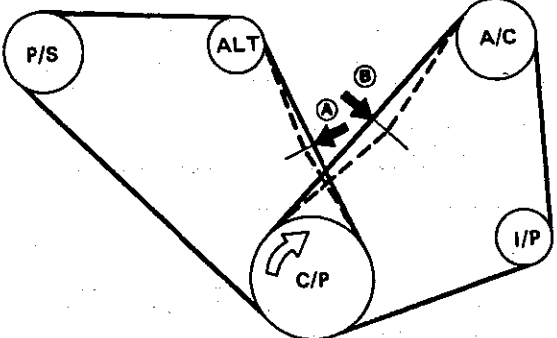
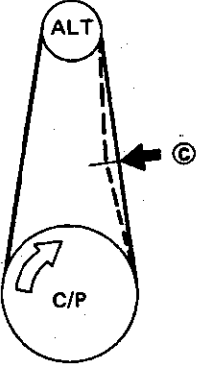
**1. Drive Belt(s)
[Except Camshaft]**

MAINTENANCE INTERVAL [Number of months or km (miles) whichever occurs first]					
Months		12	24	36	48
x1,000 km	1.6	25	50	75	100
x1,000 miles	1	15	30	45	60

A: INSPECTION

Apply a force 98 N (10 kg, 22 lb) midway between the pulleys.

- 1) Replace belts, if cracks, fraying or wear is found.
- 2) Check drive belt tension and adjust it if necessary by changing alternator installing position and/or idler pulley installing position.

Pulley arrangement	Tension mm (in)/98 N (10 kg, 22 lb)	
	A	B*
 <p><i>Fig. 1</i></p> <p>B1-294</p>	<p>New belt: 7.0 — 9.0 (0.276 — 0.354) Existing belt: 9.0 — 11.0 (0.354 — 0.433)</p>	<p>New belt: 7.5 — 8.5 (0.295 — 0.335) Existing belt: 9.0 — 10.0 (0.354 — 0.394)</p>
 <p><i>Fig. 2</i></p> <p>B1-295</p>	<p>C</p> <p>New belt: 7.0 — 9.0 (0.276 — 0.354) Existing belt: 9.0 — 11.0 (0.354 — 0.433)</p>	

C/P: Crankshaft pulley
ALT: Alternator pulley
P/S: Power steering oil pump pulley
A/C: Air conditioner compressor pulley

I/P: Idler pulley
*There is no belt [B] on models without an air conditioner.

B: REPLACEMENT

1. REMOVE V-BELT COVER.

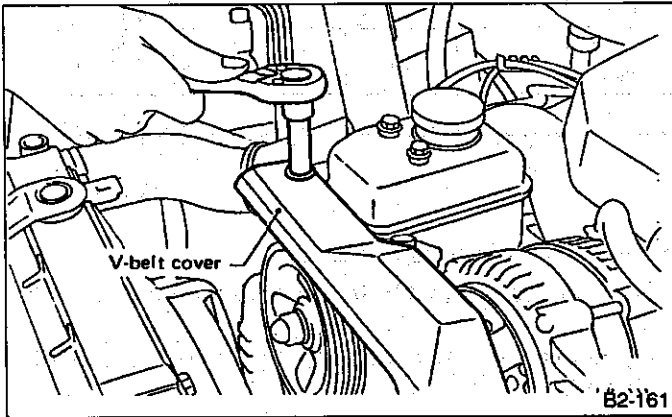


Fig. 3

**2. FRONT SIDE BELT
(Driving Power Steering Oil Pump and Alternator)**

- 1) Loosen the lock bolt on the slider bolt.
- 2) Loosen the slider bolt.

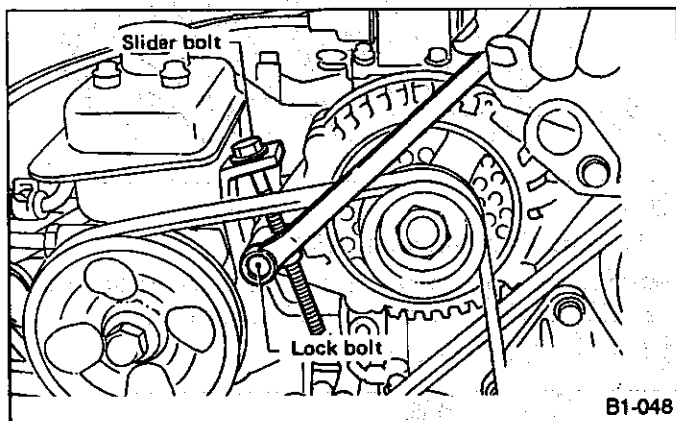


Fig. 4

- 3) Remove the front side belt.
- 4) Install a new belt, and tighten the slider bolt so as to obtain the specified belt tension shown in the above table.
- 5) Tighten the lock nut.

**Wipe off any oil or water on the belt and pulley.
(Driving Alternator only)**

- 1) Loosen alternator mounting bolts and remove belt.

- 2) Install a new belt and tighten alternator mounting bolts so as to obtain the specified belt tension shown in the above table.

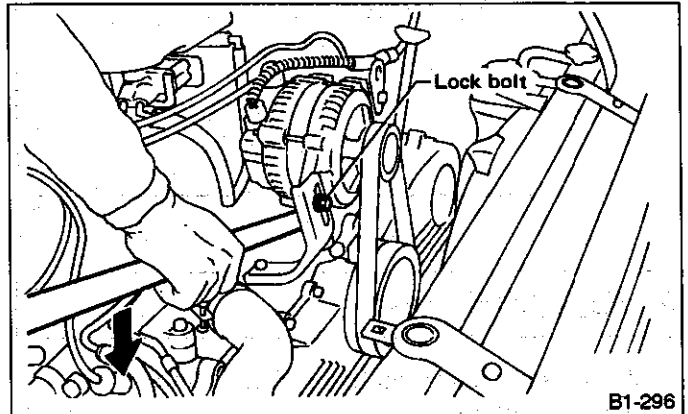


Fig. 5

- 3) Wipe off any oil or water on belt and pulleys.

**3. REAR SIDE BELT
(Driving Air Conditioner)**

Before removing the rear side belt, remove the front side belt.

- 1) Loosen the lock bolt on the slider bolt.
- 2) Loosen the slider bolt.

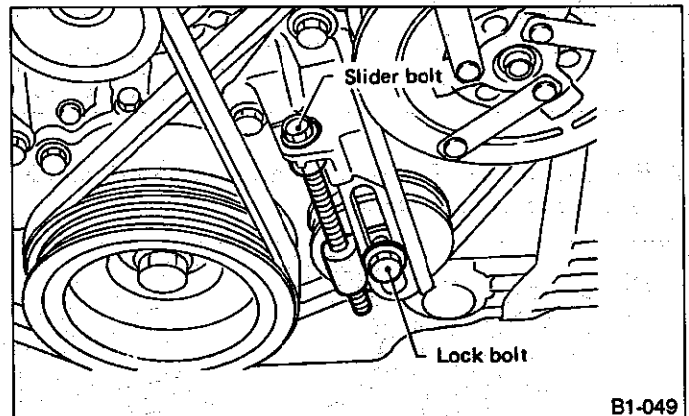


Fig. 6

- 3) Remove the rear side belt.
- 4) Install a new belt, and tighten the slider bolt so as to obtain the specified belt tension shown in the above table.
- 5) Tighten the lock nut.

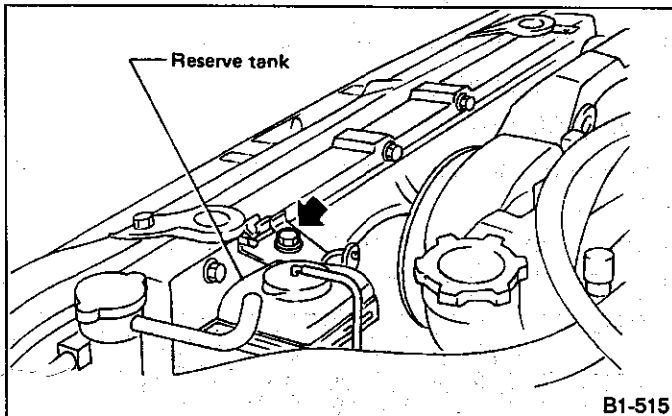
Wipe off any oil or water on the belt and pulley.

2. Camshaft Drive Belt (Timing Belt)

MAINTENANCE INTERVAL					
[Number of months or km (miles) whichever occurs first]					
Months		12	24	36	48
x1,000 km	1.6	25	50	75	100
x1,000 miles	1	15	30	45	60
					R

A: REPLACEMENT

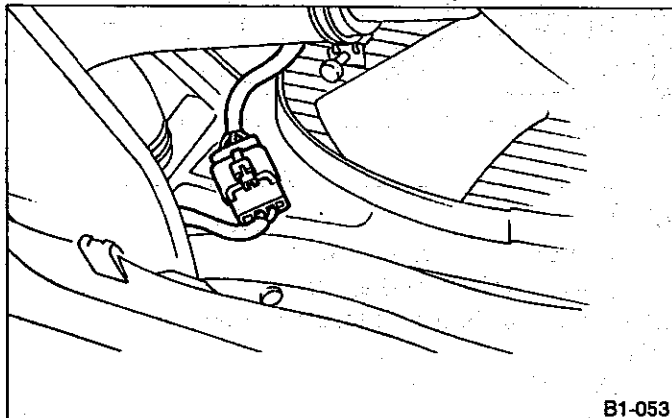
- 1) Disconnect ground cable (—) from battery.
- 2) Remove reserve tank.



B1-515

Fig. 7

- 3) Remove radiator fan motor connector and air conditioner fan motor connector.

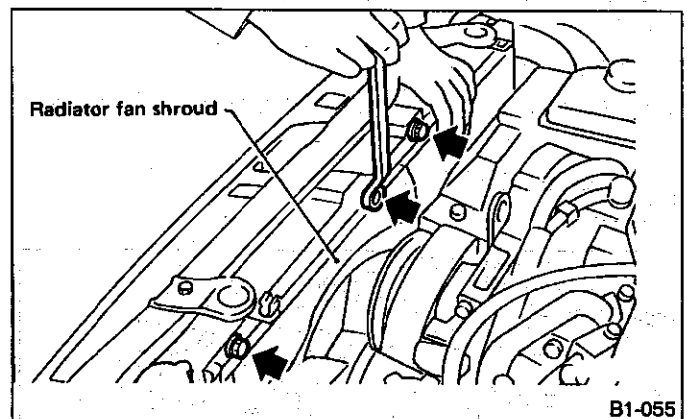


B1-053

Fig. 8

- 4) Remove radiator fan ASSY.

- (1) Remove the two bolts from the upper side of the shroud.
- (2) Loosen the two bolts at the lower side of the shroud.



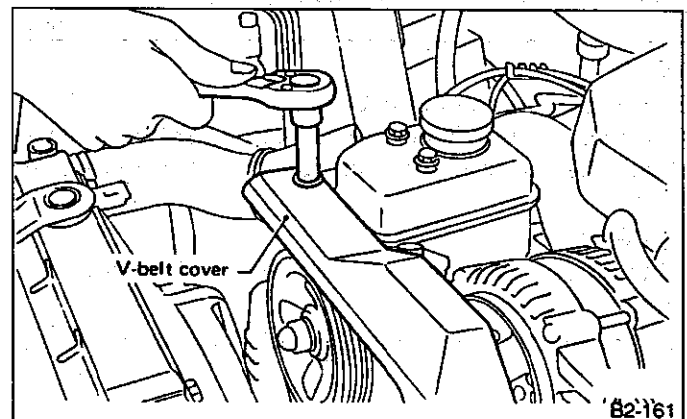
B1-055

Fig. 9

- (3) Remove radiator fan ASSY.

Remove air conditioner fan ASSY in same steps described in the removal of radiator ASSY.

- 5) Remove V-belt cover.



B2-161

Fig. 10

- 6) Remove V-belts.
[Refer to "Drive Belt(s)."]
- 7) Remove air conditioner compressor drive belt tensioner.
- 8) Remove crankshaft pulley.
- 9) Remove front belt covers.
- 10) Loosen the 2 tensioner adjuster bolts.

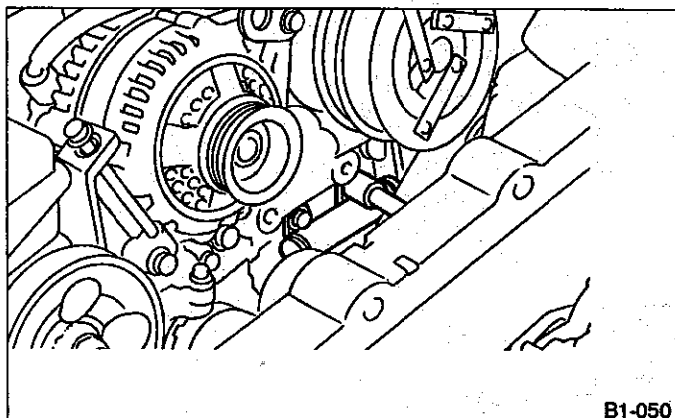


Fig. 11

- 11) Remove the 2 belt idlers.
- 12) Remove camshaft drive belt (timing belt).

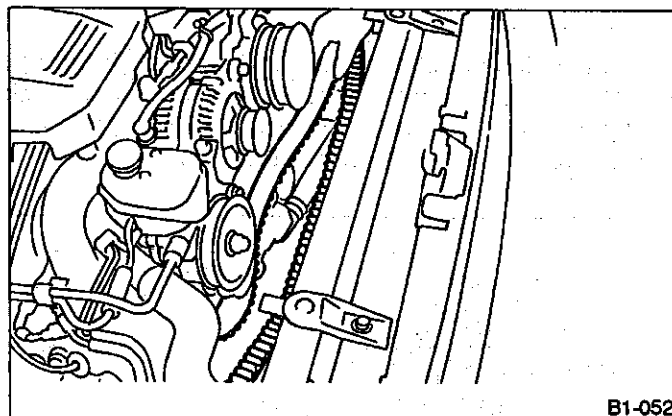


Fig. 12

For removal of camshaft drive belt, refer to "2-3 ENGINE" [W2A2].

B: INSTALLATION

To install, reverse order of removal procedures. For installation of tensioner adjuster and camshaft drive belt, refer to "2-3 ENGINE" [W2C2] [W2C3].

C: INSPECTION

1. SOHC MODEL

- 1) Remove left and right timing belt covers ① and ②.

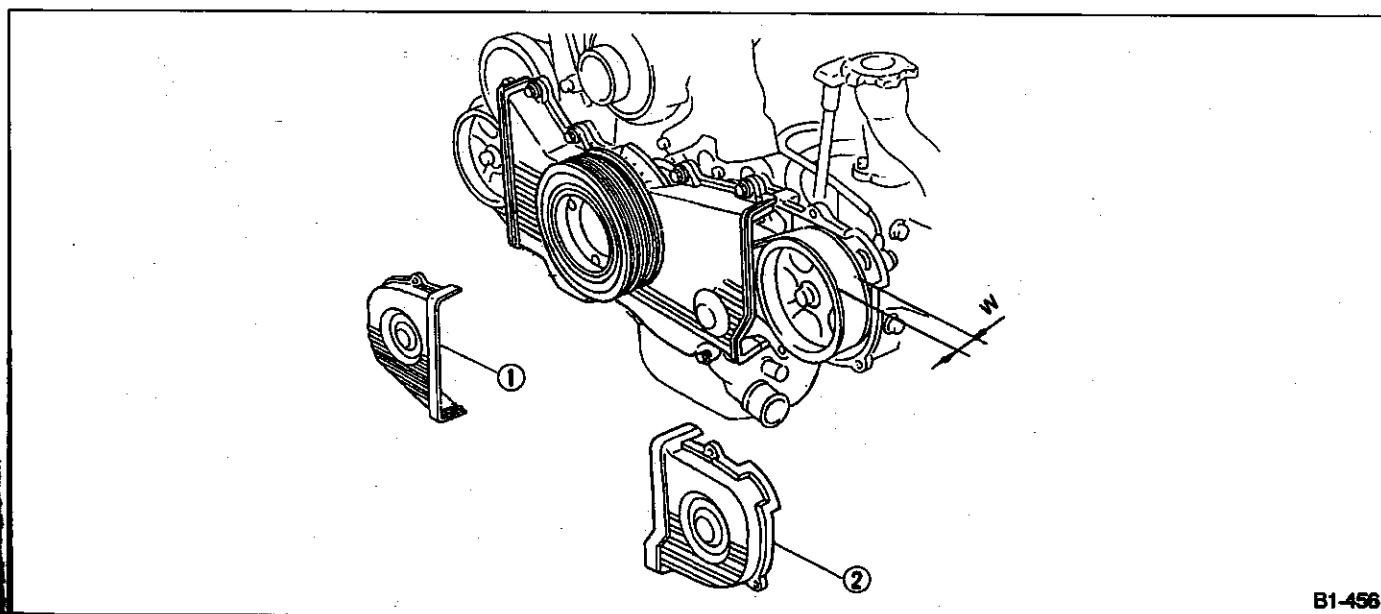


Fig. 13

- 2) While cranking engine at least four rotations, check timing belt back surface for cracks or damage. Replace faulty timing belt as needed.
- 3) Measure timing belt width W. If it is less than 27 mm (1.06 in), check idlers, tensioner, water pump pulley and

cam sprocket to determine idler alignment (squareness). Replace worn timing belt.

- 4) Install left and right timing belt covers ① and ②.

2. DOHC MODEL

- 1) Remove left and right timing belt covers ① and ②.
- 2) While cranking engine at least four rotations, check timing belt back surface for cracks or damage, if a fault is found replace the bolt with a new one.

- 3) Measure timing belt width W. If it is less than 30 mm (1.18 in), check idlers, tensioner, water pump pulley and cam sprocket to determine idler alignment (squareness). Replace worn timing belt.
- 4) Install left and right timing belt covers ① and ②.

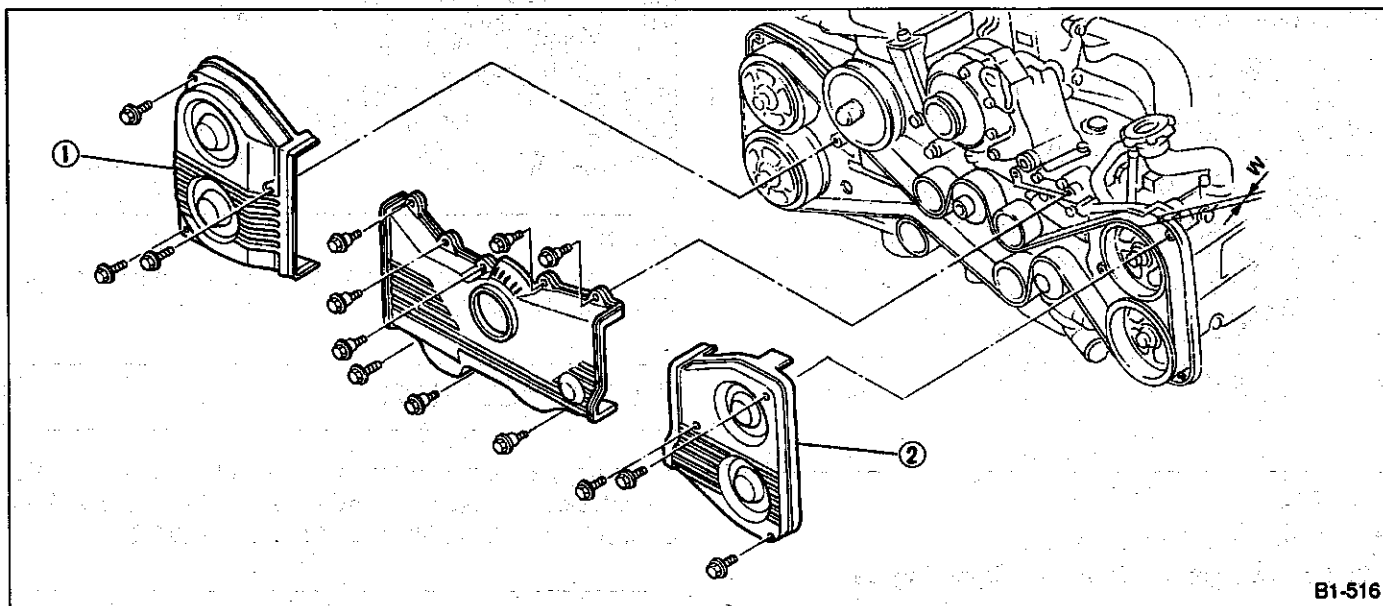


Fig. 14

3. Engine Oil

MAINTENANCE INTERVAL					
[Number of months or km (miles) whichever occurs first]					
Months		12	24	36	48
x1,000 km	1.6	25	50	75	100
x1,000 miles	1	15	30	45	60
Change every 12,500 km (7,500 miles) or 6 months, whichever occurs first.					

A: REPLACEMENT

1) Drain engine oil by loosening engine oil drain plug.

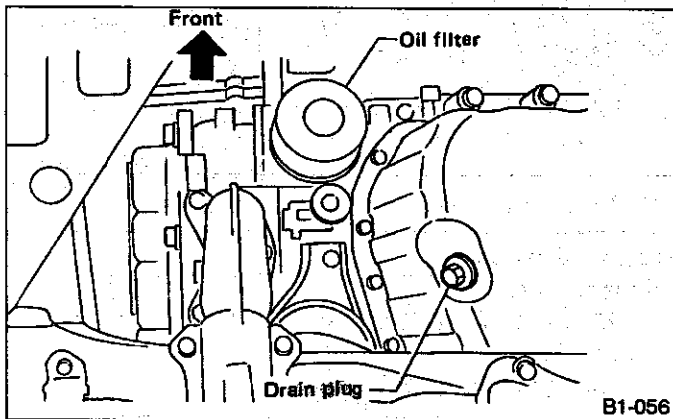


Fig. 15

2) Open engine oil filler cap for quick draining of the engine oil.

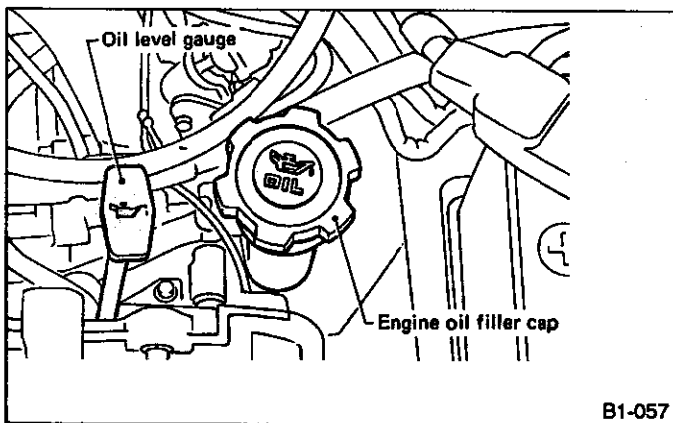


Fig. 16

3) Tighten engine oil drain plug after draining engine oil.

Tightening torque:

44 N·m (4.5 kg-m, 33 ft-lb)

4) Fill engine oil through filler pipe up to upper point on level gauge. Make sure that vehicle is placed level when checking oil level. Use engine oil of proper quality and viscosity, selected in accordance with the table below.

● Recommended oil

API classification: SF or SG

SAE Viscosity No. and Applicable Temperature							
(°F)	-30	-14.8	0	23	30	60	90
(°C)	-34	-26	-18	5	0	16	32
	10W-30, 10W-40						*1
	10W-30, 10W-40						*2
	5W-30						

Fig. 17

*1: For Carburetor engine

*2: For SPFI, MPFI and TURBO engine

The proper viscosity helps car get good cold and hot starting by reducing viscous friction and thus increasing cranking speed.

a. Insert the oil level gauge into gauge hole in proper direction as figure.

b. When replenishing oil, it does not matter if the oil to be added is a different brand from that in the engine, however, use oil having the API classification and SAE viscosity No. designated by SUBARU.

c. SAE 5W-30 is not recommended for sustained high speed driving.

d. If vehicle is used in desert areas or areas with very high temperatures or for other heavy duty applications, the following viscosity oils may be used:

"30, 40, 10W — 50, 20W — 40, 20W — 50"

5) Close engine oil filler cap.

6) Recheck the oil level when the engine is cold. If necessary, add oil up to the upper pain on level gauge.

B: INSPECTION

1) Park vehicle on a level surface.

2) Remove oil level gauge and wipe it clean.

3) Reinsert the level gauge all the way. Be sure that the level gauge is correctly inserted and in the proper orientation, with the symbol on the top appearing as shown in the figure.

4) Remove it again and note the reading. If the engine oil level is below the "L" line, add oil to bring the level up to the "F" line.

5) After turning off the engine, wait a few minutes for the oil to drain back into the oil pan before checking the level.

6) Just after driving or while the engine is warm, engine oil level may show in the range between the "F" line and the notch mark. This is caused by thermal expansion of the engine oil.

7) To prevent overfilling the engine oil, do not add oil above the "F" line when the engine is cold.

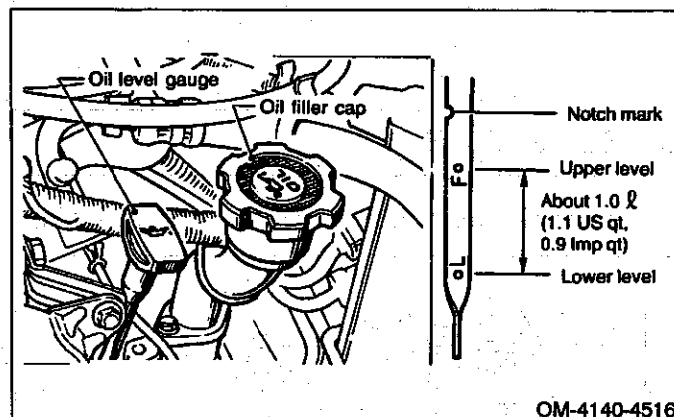


Fig. 18

Engine oil capacity:

Upper level

4.5 l (4.8 US qt, 4.0 Imp qt)

Lower level

3.5 l (3.7 US qt, 3.1 Imp qt)

4. Engine Oil Filter

MAINTENANCE INTERVAL [Number of months or km (miles) whichever occurs first]					
Months		12	24	36	48
x1,000 km	1.6	25	50	75	100
x1,000 miles	1	15	30	45	60
Change every 12,500 km (7,500 miles) or 6 months, whichever occurs first.					

A: REPLACEMENT

- 1) Remove oil filter with an oil filter wrench.
- 2) Get a new oil filter and apply a thin coat of engine oil to the seal rubber.
- 3) Install oil filter by turning it with hand, being careful not to damage seal rubber.
- 4) Tighten more approximately two thirds turn after the seal rubber contacts the oil pump case. Do not tighten excessively, or oil may leak.
- 5) After installing oil filter, run engine and make sure that no oil is leaking around seal rubber.

The filter element and filter case are permanently joined; therefore, interior cleaning is not necessary.

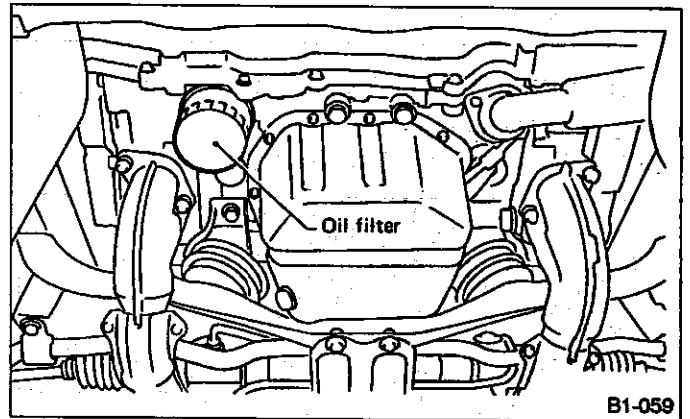


Fig. 19

B1-059

5. Replace Engine Coolant and Inspect Cooling System, Hoses and Connections

MAINTENANCE INTERVAL (Number of months or km (miles), whichever occurs first)									
Months	3	7.5	15	22.5	30	37.5	45	52.5	60
x1,000 km	4.8	12	24	36	48	60	72	84	96
x1,000 miles	3	7.5	15	22.5	30	37.5	45	52.5	60
					P				P

A: REPLACEMENT

1. REPLACEMENT OF COOLANT

• Non-TURBO model

- 1) Fit end of vinyl tube into drain pipe.

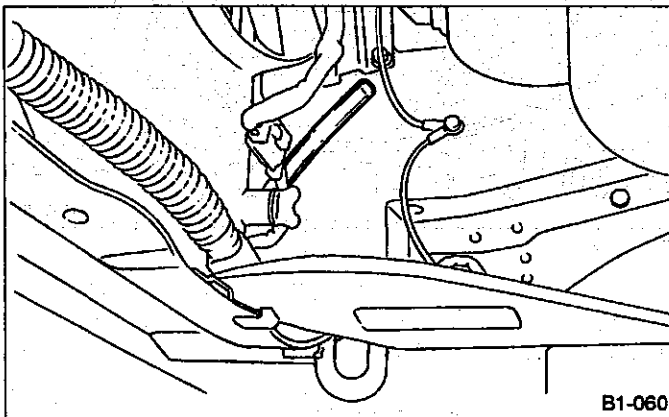


Fig. 20

- 2) Place a container under drain tube, and loosen drain plug.
- 3) Loosen radiator cap to drain coolant.
- 4) Drain coolant from reserve tank.
- 5) Remove two drain plugs on engine side, and drain coolant.

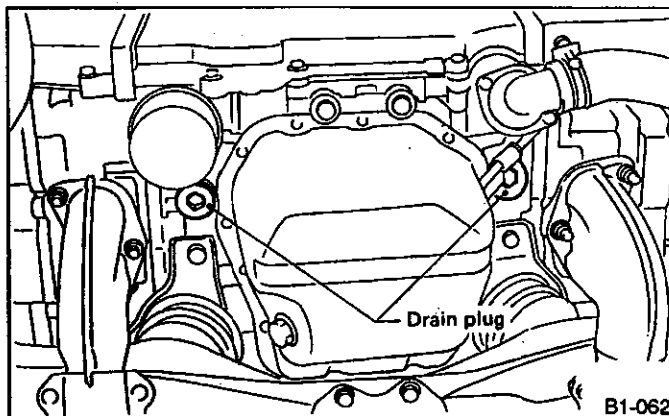


Fig. 21

- 6) Securely tighten engine side drain plugs.
 - 7) Tighten radiator drain plug securely after draining coolant. (Drain tube may face downward.)
 - 8) Install reserve tank to original position.
 - 9) Remove air vent plug.
 - 10) Slowly pour prepared coolant from radiator filler port to neck of filler, then pour into reserve tank up to "FULL" level.
 - 11) Install air vent plug.
 - 12) Securely install radiator cap.
 - 13) Run engine for more than five minutes at 2,000 to 3,000 rpm. (Run engine until radiator becomes hot in order to purge air trapped in cooling system.)
 - 14) Stop engine and wait until coolant temperature lowers. Then open radiator cap to check coolant level and add coolant up to radiator filler neck. Next, add coolant into reserve tank up to "FULL" level.
- The radiator is of the pressurized type. Do not attempt to open the radiator cap immediately after the engine has been stopped.**
- 15) After adding coolant, securely install radiator and reserve tank caps.

• TURBO model

- 1) Loosen radiator drain plug after following the same procedures 1) and 2) as described for the Non-TURBO engine.
- 2) Loosen coolant flow tank cap to drain coolant.
- 3) Remove the two drain plugs on engine side, and drain coolant.
- 4) Securely tighten engine side drain plugs after draining coolant.
- 5) Tighten radiator drain plug securely.
- 6) Slowly pour prepared coolant from coolant flow tank filler port up to the brim of port, and install cap, then pour coolant into reserve tank up to "FULL" level.
- 7) Run engine for about 15 minutes, not exceeding 2,000 rpm. (Run engine until radiator becomes hot in order to purge air trapped in cooling system.)
- 8) Stop engine and wait until coolant temperature lowers. [below 50°C (122°F) or 60°C (140°F)] Open coolant flow tank cap and add coolant up to the brim of the port.

PERIODIC MAINTENANCE SERVICES

9) Wait until coolant temperature lowers further [below 30°C (86°F)], then pour into reserve tank up to the "FULL" level.

10) Run the vehicle until the coolant temperature rises to 80°C (176°F) and check the level in the coolant flow tank, add coolant up to the "FULL" level.

The radiator for the turbo engine does not have an air vent plug.

Coolant capacity (fill up to "FULL" level):

1800 cc, 1600 cc

Approx. 6.3 ℓ (6.7 US qt, 5.5 Imp qt)

2000 cc

Approx. 6.1 ℓ (6.4 US qt, 5.4 Imp qt)

2000 cc TURBO

Approx. 7.2 ℓ (7.6 US qt, 6.3 Imp qt)

2200 cc

Approx. 5.9 ℓ (6.2 US qt, 5.2 Imp qt)

The SUBARU Genuine Coolant containing anti-freeze and anti-rust agents is especially made for SUBARU engine, which has an aluminum crankcase. Always use SUBARU Genuine Coolant, since other coolant may cause corrosion.

2. RELATIONSHIP OF SUBARU COOLANT CONCENTRATION AND FREEZING TEMPERATURE

The concentration and safe operating temperature of the SUBARU coolant is shown in the following diagram. Measuring the temperature and specific gravity of the coolant will provide this information.

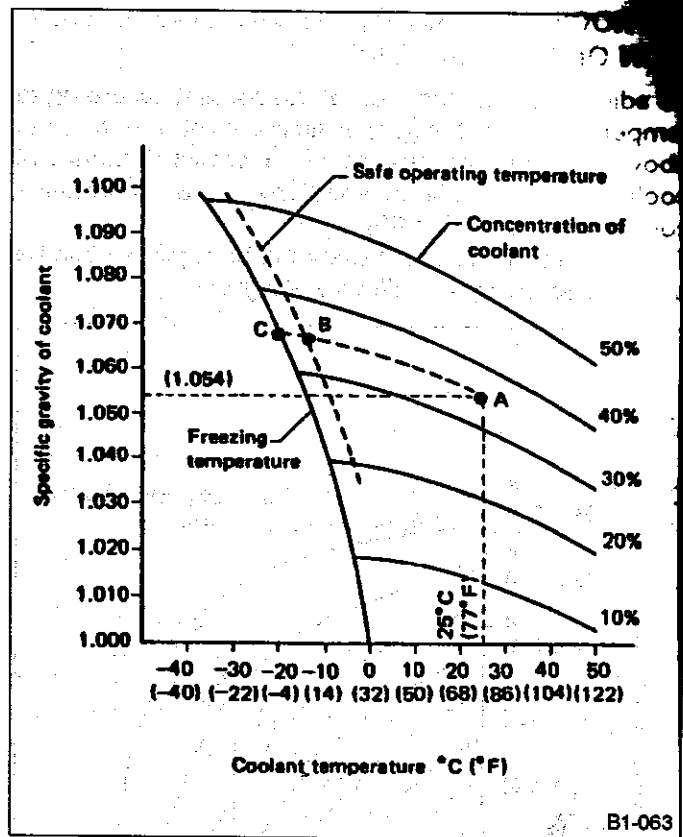


Fig. 22

[Example] If the coolant temperature is 25°C (77°F) and its specific gravity is 1.054, the concentration is 35% (point A), the safe operating temperature is -14°C (7°F) (point B), and the freezing temperature is -20°C (-4°F) (point C).

3. PROCEDURE TO ADJUST THE CONCENTRATION OF THE COOLANT

To adjust the concentration of the coolant according to temperature, find the proper fluid concentration in the above diagram and replace the necessary amount of coolant with an undiluted solution of SUBARU genuine coolant (concentration 50).

The amount of coolant that should be replaced can be determined using the following diagram.

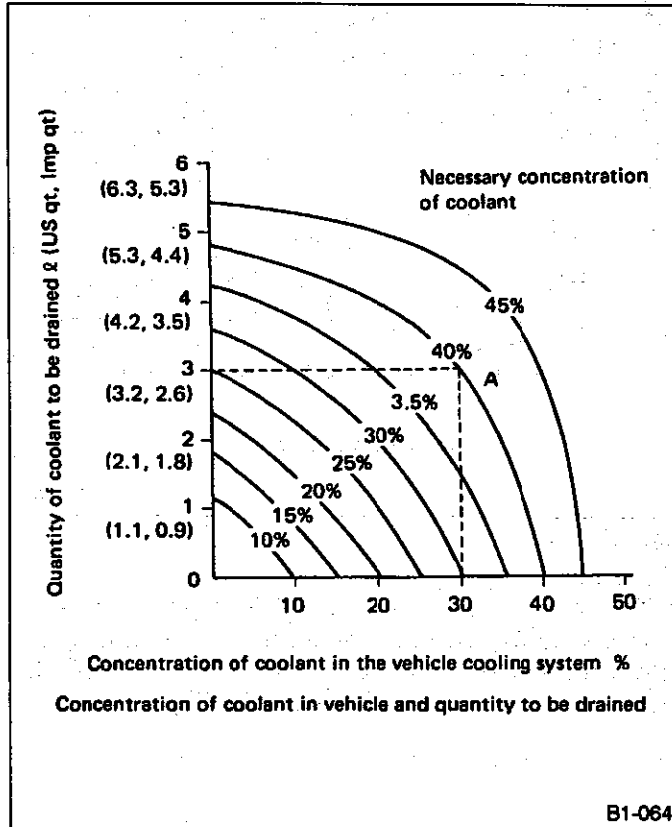


Fig. 23

[Example]

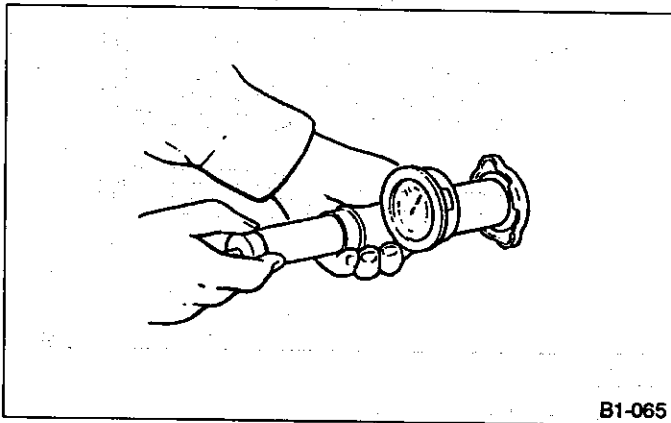
Assume that the coolant concentration must be increased from 30% to 40%. Find point A, where the 30 line of coolant concentration intersects with the 40% curve of the necessary coolant concentration, and read the scale on the vertical axis of the graph at height A. The quantity of coolant to be drained is 3.0 liters (3.2 US qt, 2.6 Imp qt). Drain 3.0 liters (3.2 US qt, 2.6 Imp qt) of coolant from the cooling system and add 3.0 liters (3.2 US qt, 2.6 Imp qt) of the undiluted solution of SUBARU coolant.

If a coolant concentration of 50% is needed, drain all the coolant and refill with the undiluted solution only.

B: INSPECTION

- 1) Check the radiator reserve tank and hoses for damage or clogging.
 - 2) Check the hose connections for leakage.
 - 3) Check the valve, spring and packing in the cap for damage.
 - 4) Check rubber seal on cap for tears, cracks or deterioration after cleaning it.
- Install the cap on a tester and if cap does not hold or does not release the specified pressure, replace cap.

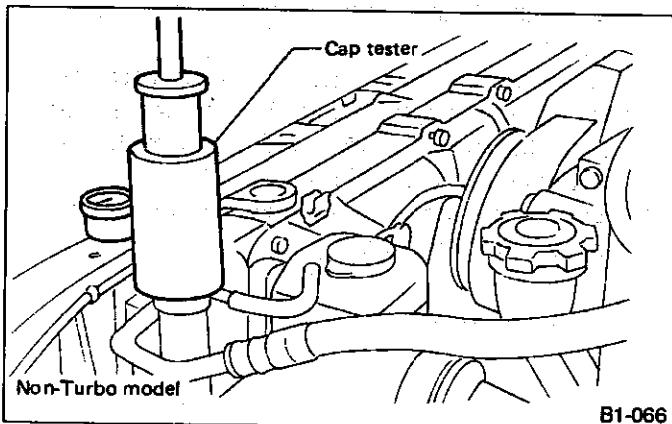
Cap relief pressure:
88 kPa (0.9 kg/cm², 13 psi)



B1-065

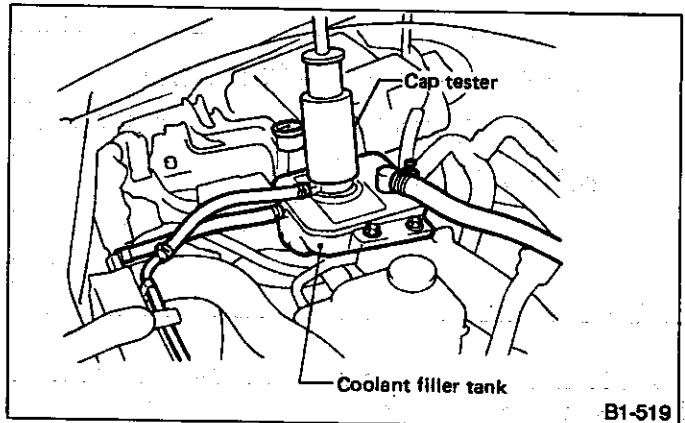
Fig. 24

- 5) Check the radiator for leakage. Inspect radiator for leakage using a cap tester and applying a pressure of 157 kPa (1.6 kg/cm², 23 psi). If a leakage is detected, repair or replace the radiator.



B1-066

Fig. 25



B1-519

Fig. 26

- 6) If the coolant temperature exceeds 76.0 to 80.0°C (169 to 176°F) while radiator is not so hot, check thermostat.
- 7) If thermostat does not open at 76.0 to 80.0°C (169 to 176°F), replace it with a new one.
- 8) If electric fan does not operate with coolant temperature above 90.0 to 94.0°C (194 to 201°F), check thermostat or fan motor. (carburetor equipped model only)

6. Replace Fuel Filter and Inspect Fuel System, Lines and Connections

MAINTENANCE INTERVAL					
[Number of months or km (miles) whichever occurs first]					
Months		12	24	36	48
x1,000 km	1.6	25	50	75	100
x1,000 miles	1	15	30	45	60
			P		P

A: REPLACEMENT

a. Before starting the job, be sure to carry out the following.

- Place "No fire" signs near the working area.
 - Disconnect ground cable from battery.
- b. Be careful not to spill fuel on the floor.

1. CARBURETOR

1) Removal

- (1) Remove the fuel filter from the holder.
- (2) Unfasten the clip which connects the fuel hose to the fuel filter, and disconnects the hose.

Fuel filter can not be disassembled as it is of the cartridge type.

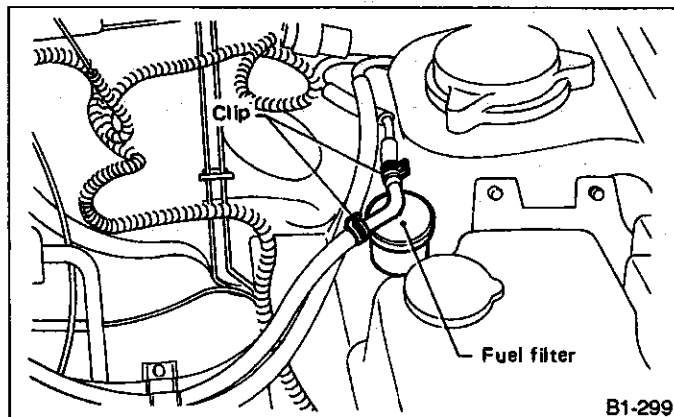
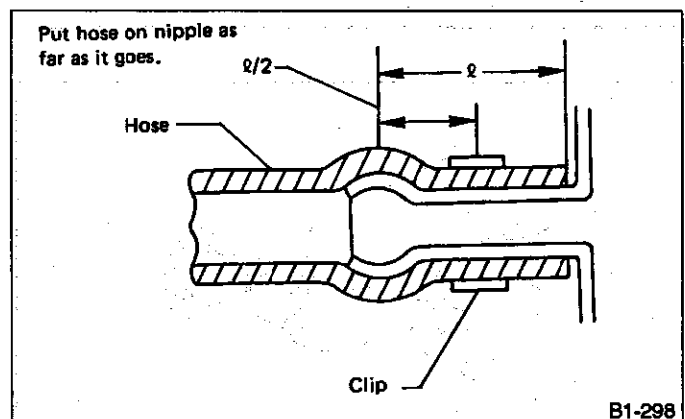


Fig. 27

B1-299

2) Installation

(1) Connect the hose as shown in the figure below:



B1-298

Fig. 28

(2) Install the filter to the holder.

2. SPFI AND MPFI

1) Removal

(1) Before removing the hose, filter, pump, etc., be sure to release the fuel pressure, as follows:

- Disconnect the wiring connector of the fuel pump.
- Crank the engine for more than five seconds. If the engine starts, let the engine run until it stops.
- After turning IG switch OFF, connect the wiring connector of the fuel pump.

(2) Loosen the screw of the hose clamp and pull off the hose from the filter.

(3) Remove the filter from the holder.

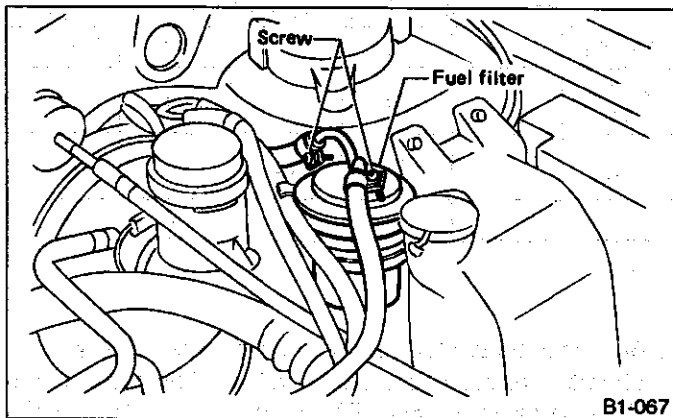


Fig. 29

2) Installation

- (1) Install the filter to the holder.
- (2) Connect the hose as illustrated below:

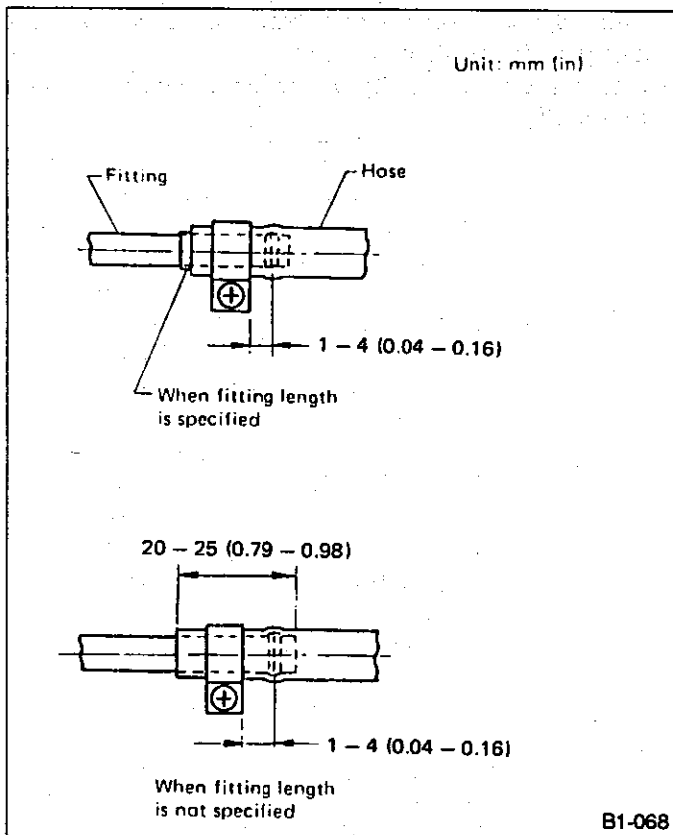


Fig. 30

(3) Tighten the hose clamp screw to the specified torque.

Tightening torque:

1.0 — 1.5 N·m (0.1 — 0.15 kg-m, 0.7 — 1.1 ft-lb)

- a. If the hose is damaged at the clamping portion, replace the hose with a new one.
- b. If the hose clamp is too deformed, replace with a new one.
- c. Correct the hose position by removing any twist so that it will not interfere with the filter body or washer tank, before tightening the screw of the hose clamp.

B: INSPECTION

1. FUEL PIPING AND CONNECTIONS

Check fuel piping and connections for leakage, scratches, swelling and corrosion.

7. Air Cleaner Element

MAINTENANCE INTERVAL					
[Number of months or km (miles) whichever occurs first]					
Months		12	24	36	48
x1,000 km	1.6	25	50	75	100
x1,000 miles	1	15	30	45	60
		I	R	I	R

A: INSPECTION

Inspect or change the elements at the specified intervals. Under extremely dusty conditions, inspect or change more often.

B: REPLACEMENT

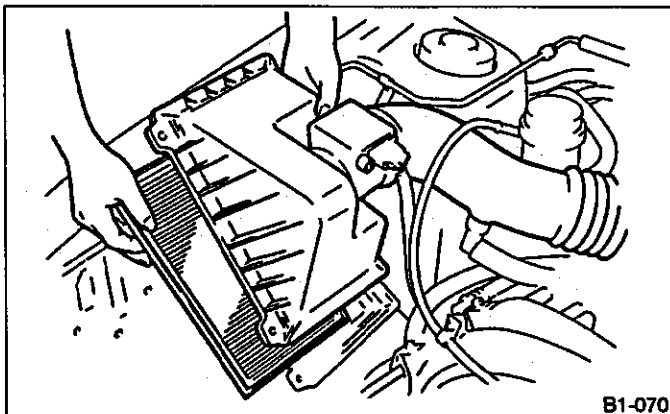


Fig. 31 2200 cc and 2000 cc

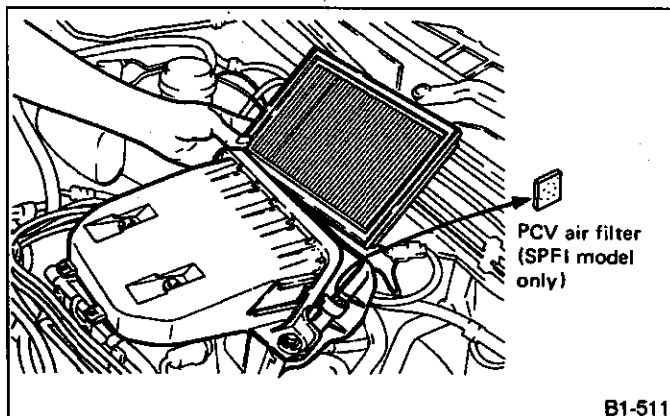


Fig. 32 1800 cc and 1600 cc

- a. Do not attempt to clean the air cleaner element. The filter paper of the element is wetted with a special non-inflammable slow-evaporating viscous liquid. It is resistant to cold weather and has a long service life. Dirt adhering to this filter paper forms porous laminations with the viscous liquid, which function as a filtration layer to reduce dust penetration into the filter paper. If this filter paper is cleaned, the filtration layer thus formed will be lost along with the viscous liquid.
- b. Under extremely dusty conditions, replace it more frequently.

8. Spark Plugs

MAINTENANCE INTERVAL					
[Number of months or km (miles) whichever occurs first]					
Months		12	24	36	48
x1,000 km	1.6	25	50	75	100
x1,000 miles	1	15	30	45	60
		R	R	R	R
For TURBO			R		R

A: REPLACEMENT

1800 cc, 1600 cc:

Carburetor

Recommended spark plug

NGK BKR6E

NIPPONDENSO K20PR-U

Spark plug gap

0.8 mm (0.031 in)

SPFI

Recommended spark plug

NGK BKR6E-11

NIPPONDENSO K20PR-U11

Spark plug gap

1.0 — 1.1 mm (0.039 — 0.043 in)

2000 cc (Turbo)

Recommended spark plug

NGK BKR6EVX

Spark plug gap

0.7 — 0.8 mm (0.028 — 0.031 in)

2200 cc, 2000 cc (Non-Turbo)

Without O₂ sensor

Recommended spark plug

NGK BKR6E

NIPPONDENSO K20PR-U

Spark plug gap

0.8 mm (0.031 in)

With O₂ sensor

Recommended spark plug

NGK BKR6E-11

NIPPONDENSO K20PR-U11

Spark plug gap

1.0 — 1.1 mm (0.039 — 0.043 in)

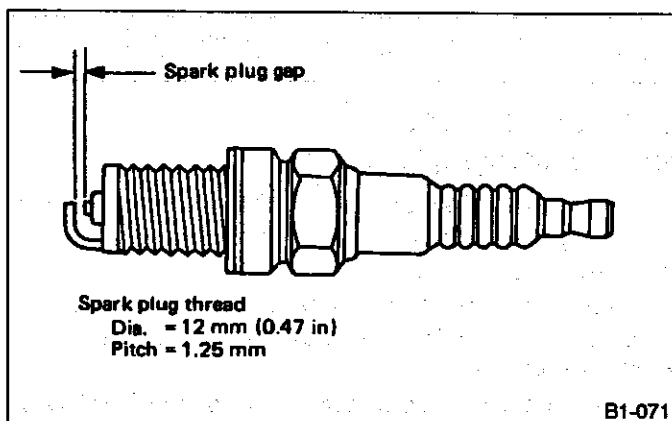


Fig. 33

When installing spark plugs on cylinder head, tighten to the specified torque.

Tightening torque:

18 — 24 N•m (1.8 — 2.4 kg-m, 13 — 17 ft-lb)

- Be sure to place the gasket between the cylinder head and spark plug.
- If torque wrench is not available, tighten spark plug until gasket contacts cylinder head; then tighten further 1/4 to 1/2 turns.

9. Engine Idle Speed (for carburetor engine only) and Idle Mixture (not necessary for catalytic converter equipped vehicles)

MAINTENANCE INTERVAL					
[Number of months or km (miles) whichever occurs first]					
Months		12	24	36	48
x1,000 km	1.6	25	50	75	100
x1,000 miles	1	15	30	45	60

A: INSPECTION AND ADJUSTMENT

1. ENGINE IDLE SPEED

(for carburetor engine only)

- Before measuring the engine idle speed, make sure that the ignition timing is within specifications. (Refer to C.2-2 [02A0].)
- Make sure that vacuum hoses, blow-by hoses and other hoses which are connected to the intake system, are tight and secure.
- Clog the purge hose to carburetor after disconnecting it.

- Set the gear position at "Neutral" for MT, or "N" or "P" for AT.
- Warm up engine sufficiently until cooling fan starts to operate.
- Measure the engine idle speed using the tachometer.

At this time, make sure that cooling fan, head light, air conditioner and heater are turned OFF.

Engine idle speed:

1800 cc	800 ± 50 rpm
1600 cc	900 ± 50 rpm

- If out of specifications, adjust using the throttle adjusting screw on carburetor.

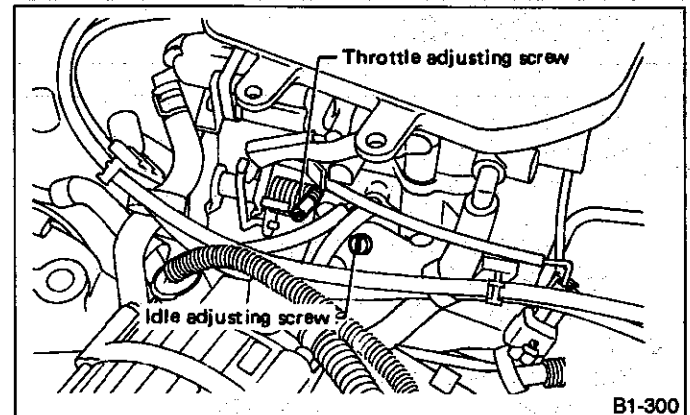


Fig. 34

2. IDLE MIXTURE

(not necessary for catalytic converter equipped vehicle)

[Carburetor model]

- Before measuring the idle mixture, make sure that the ignition timing and the engine idle speed are within specifications.
 - Make sure that vacuum hoses, blow-by hoses, and other hoses which are connected to the intake system, are tight and secure.
- Set the gear position at "Neutral" for MT, or "N" or "P" for AT.
 - Warm up engine sufficiently until cooling fan starts to operate.
 - Measure the idle mixture with the CO meter.

Engine idle speed	CO (%)
800 ± 50 rpm	1.0 ± 0.5

- If out of specification, adjust using the idle mixture adjusting screw on carburetor.

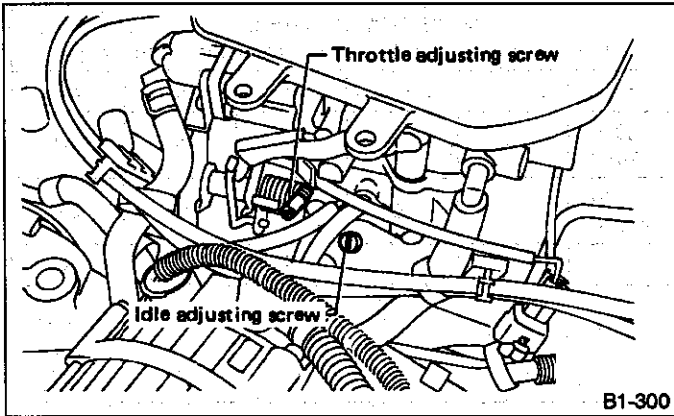


Fig. 35

[MPFI model]

Before measuring the idle mixture, make sure that the ignition timing and the engine idle speed are within specifications.

- 1) Set the gear position at "Neutral" for MT, or "N" or "P" at AT.
- 2) Warm up engine sufficiently until cooling fan starts to operate.

3) Measure the idle mixture with the CO meter.

Engine idle speed	CO (%)
800 ± 100 rpm	1.0 ± 0.5

4) If out of specification, adjust using the idle mixture adjusting screw on air flow meter.

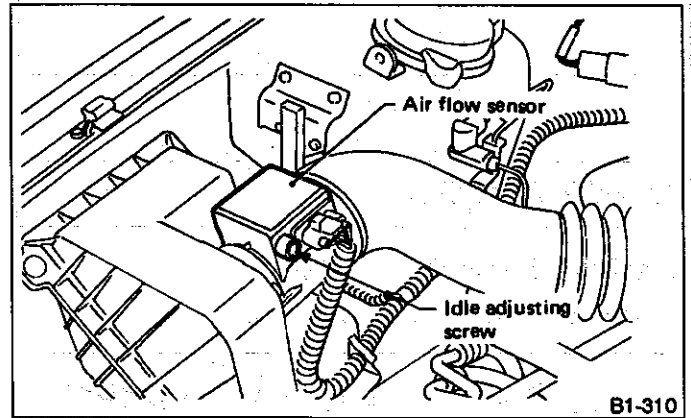


Fig. 36

10. Transmission/Differential (Front and Rear) Gear Oil and Automatic Transmission Fluid

MAINTENANCE INTERVAL [Number of months or km (miles) whichever occurs first]					
Months		12	24	36	48
x1,000 km	1.6	25	50	75	100
x1,000 miles	1	15	30	45	60
			R		R

A: REPLACEMENT

1. MANUAL TRANSMISSION

1) Drain oil by removing drain plug.

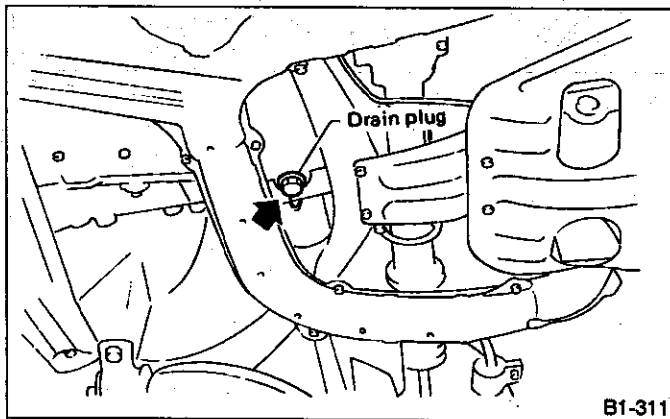


Fig. 37

2) Reinstall drain plug after draining oil and tighten it to the specified torque.

Tightening torque: N·m (kg-m, ft-lb)
41 — 47 (4.2 — 4.8, 30 — 35)

- a. Be sure to place a gasket between the transmission case and drain plug.
 - b. Replace the gasket with a new one.
- 3) Fill transmission gear oil through the oil level gauge hole up to upper point on level gauge.

Oil capacity

Unit: ℓ (US qt, Imp qt)

1800 cc 1600 cc	FWD	2.6 (2.7, 2.3)
1800 cc 2200 cc	4WD (Selective) FWD	3.3 (3.5, 2.9)
1800 cc 2000 cc 2200 cc	4WD (Center differential)	3.5 (3.7, 3.1)

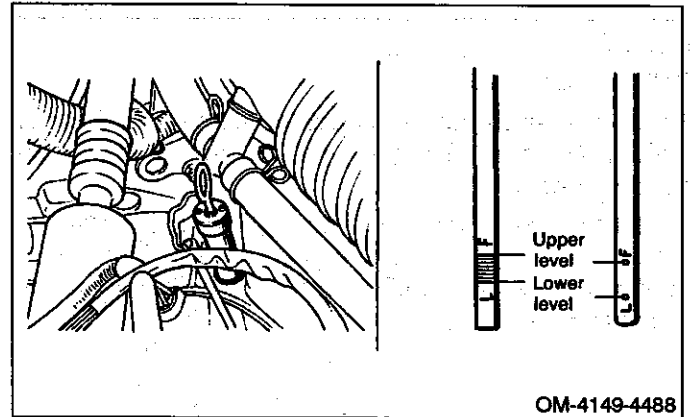


Fig. 38

2. AUTOMATIC TRANSMISSION

1) Drain fluid by removing drain plug after allowing the engine to cool for 3 to 4 hours.

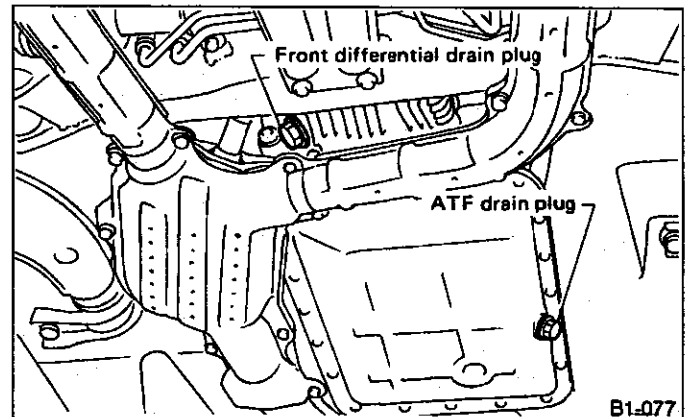


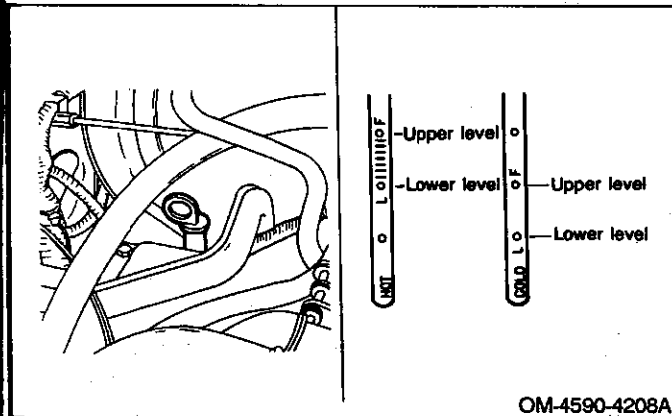
Fig. 39 4AT

2) Reinstall drain plug after draining fluid, and tighten it to the specified torque.

Tightening torque:
25 N·m (2.5 kg-m, 18 ft-lb)

- a. Be sure to place a gasket between oil pan and drain plug.
 - b. Replace the gasket with a new one.
- 3) Fill ATF through the fluid level gauge hole.

Fluid capacity: ℓ (US qt, Imp qt)
 4AT 8.0 — 8.6 (8.5 — 9.1, 7.0 — 7.6)



OM-4590-4208A

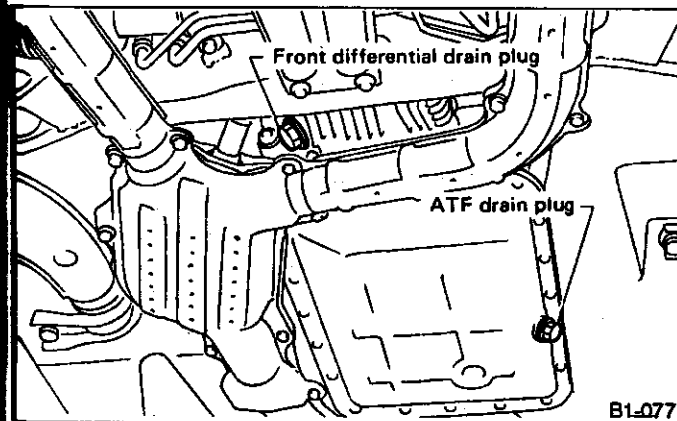
Fig. 40 4AT

4) Run the vehicle until the ATF temperature rises to 60 to 80°C (140 to 176°F) and the check the ATF level.

Recommended automatic transmission fluid:
 ATF Dexron II

**3. FRONT DIFFERENTIAL
 (Automatic Transmission)**

1) Drain oil by removing front differential drain plug.



B1-077

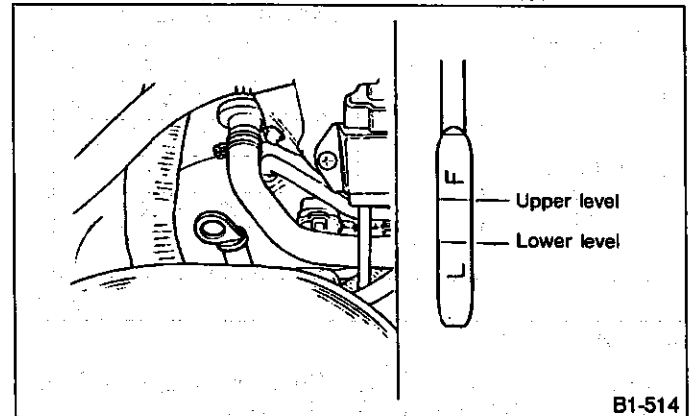
Fig. 41 4AT

2) Reinstall drain plug after draining oil, then tighten it to the specified torque.

Tightening torque:
 25 N•m (2.5 kg-m, 18 ft-lb)

- a. Be sure to place a gasket between the differential gear case and the drain plug.
 - b. Replace the gasket with a new one.
- 3) Fill differential gear oil through the oil level gauge hole up to upper point on the level gauge.

Oil capacity: ℓ (US qt, Imp qt)
 4AT 1.1 — 1.3 (1.2 — 1.4, 1.0 — 1.1)



B1-514

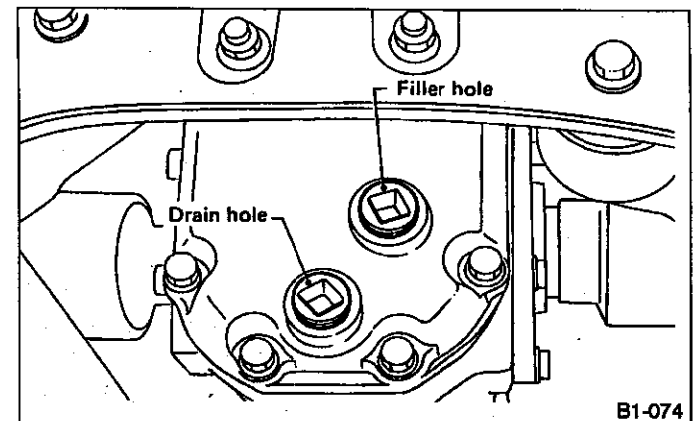
Fig. 42 4AT

**4. REAR DIFFERENTIAL
 (4WD Vehicle)**

- 1) Drain oil by removing drain plug.
- 2) After installing drain plug onto rear differential gear case firmly, fill oil up fully to the mouth of filler hole.

Oil capacity:
 0.8 ℓ (0.8 US qt, 0.7 Imp qt)

3) Install filler hole plug onto rear differential gear case firmly.



B1-074

Fig. 43

Recommended oil

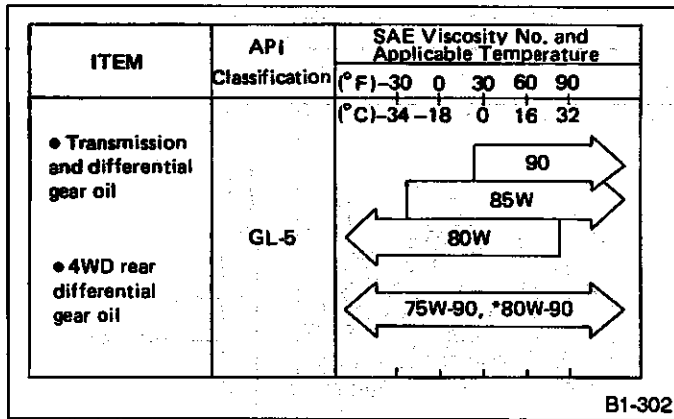


Fig. 44

- a. Each oil manufacturer has its base oil and additives. Thus, do not mix two or more brands.
- b. *For differential gear oil (AT)
- c. Apply fluid packing to drain plug threads before installation.

Fluid packing:

Three Bond 1105 or equivalent

Drain plug tightening torque:

44 N·m (4.5 kg-m, 33 ft-lb)

11. Brake Fluid

MAINTENANCE INTERVAL					
[Number of months or km (miles) whichever occurs first]					
Months		12	24	36	48
x1,000 km	1.6	25	50	75	100
x1,000 miles	1	15	30	45	60
			R		R

A: REPLACEMENT

- a. The FMVSS No. 116, fresh DOT3 or 4 brake fluid must be used.
 - b. Cover bleeder with waste cloth, when loosening it, to prevent brake fluid from being splashed over surrounding parts.
 - c. Avoid mixing different brands of brake fluid to prevent degrading the quality of the fluid.
 - d. Be careful not to allow dirt or dust to get into the reservoir tank.
 - e. During bleeding operation, keep the brake reserve tank filled with brake fluid to eliminate entry of air.
 - f. Brake pedal operating must be very slow.
 - g. For convenience and safety, it is advisable to have two man working.
 - h. The amount of brake fluid required is approximately 300 ml (10.1 US fl oz, 10.6 Imp fl oz) for total brake system.
- 1) Either jack up vehicle and place a safety stand under it, or left up vehicle.
 - 2) Remove both front and rear wheels.
 - 3) Draw out the brake fluid from master cylinder with syringe.
 - 4) Refill reservoir tank with recommended brake fluid.

Recommended brake fluid

FMVSS No. 116, fresh DOT3 or 4 brake fluid

- 5) Install one end of a vinyl tube onto the air bleeder of and insert the other end of the tube into a container to collect the brake fluid.

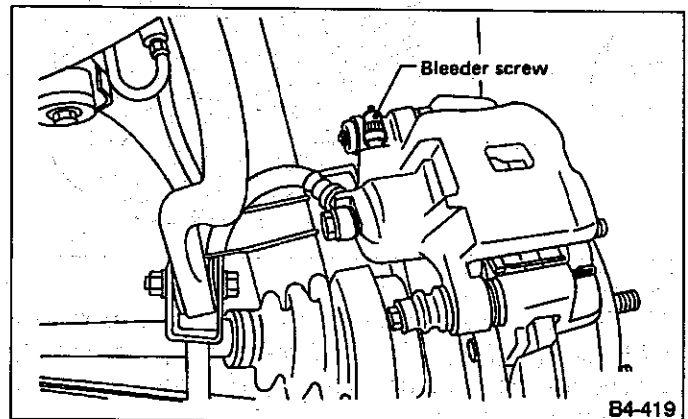


Fig. 45

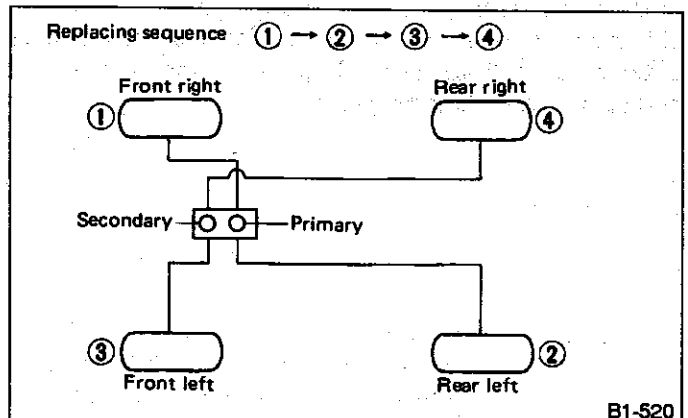


Fig. 46

- 6) Instruct your co-worker to depress the brake pedal slowly two or three times and then hold it depressed.
- 7) Loosen bleeder screw approximately 1/4 turn until a small amount of brake fluid drains into container, and then quickly tighten screw.
- 8) Repeat steps 6) and 7) above until there are no air bubbles in drained brake fluid and new fluid flows through vinyl tube.

Add brake fluid as necessary while performing the air bleed operation, in order to prevent the tank from running short of brake fluid.

- 9) After completing the bleeding operation, hold brake pedal depressed and tighten screw and install bleeder cap.

Tightening torque (Bleeder screw):**7 — 9 N·m (0.7 — 0.9 kg-m, 5.1 — 6.5 ft-lb)**

10) Bleed air from each wheel cylinder using the same procedures as described in steps 5) through 9) above.

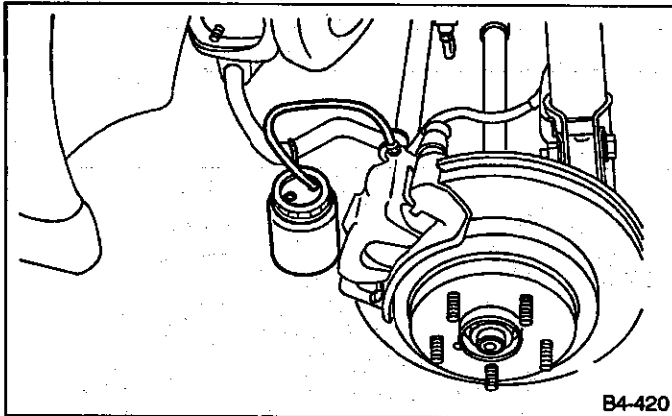


Fig. 47

11) Depress brake pedal with a force of approximately 294 N (30 kg, 66 lb) and hold it there for approximately 20 seconds. At this time check pedal to see if it shows any unusual movement.

Visually inspect bleeder screws and brake pipe joints to make sure that there is no fluid leakage.

12) Install wheels, and drive car for a short distance between 2 to 3 km (1 to 2 miles) to make sure that brakes are operating properly.

12. Disc Brake Pads and Discs /Front and Rear Axle Boots and Axle Shaft Joint Portions

MAINTENANCE INTERVAL					
[Number of months or km (miles) whichever occurs first]					
Months		12	24	36	48
x1,000 km	1.6	25	50	75	100
x1,000 miles	1	15	30	45	60

A: INSPECTION

1. DISC BRAKE PAD AND DISC (Front and Rear)

- 1) Jack up vehicle and support with rigid racks. Then remove wheels.
- 2) Visually check pad thickness through inspection hole of disc brake assembly. Replace pad if necessary.

FRONT

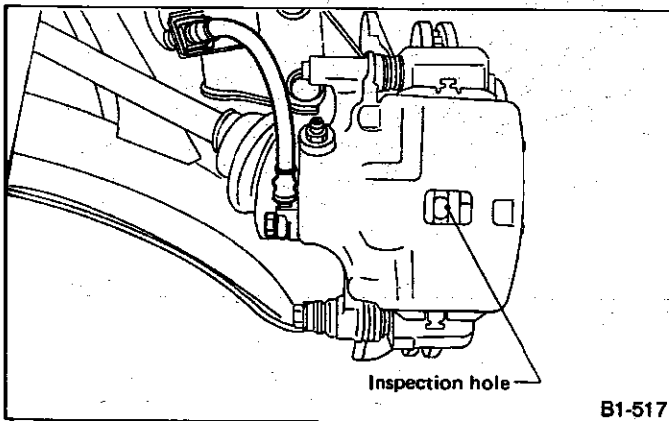


Fig. 48

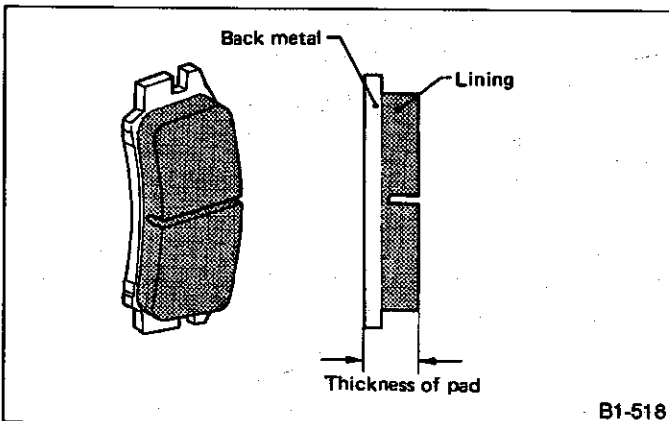


Fig. 49

REAR

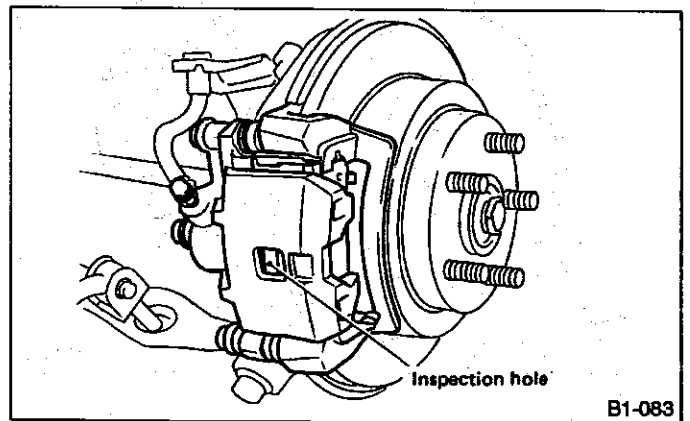


Fig. 50

Pad thickness including back metal mm (in)		
	Front	Rear
Standard	17 (0.67)	15 (0.59)
Wear limit	7.5 (0.295)	6.5 (0.256)
Wear limit (exclude back metal)	1.5 (0.059)	1.5 (0.059)

- When replacing a pad, always replace the pads for both the left and right wheels at the same time. Also replace pad clips if they are twisted or worn.
- The clip incorporated with pad is also used as a warning device for worn pads. When wear occurs on the pad to such an extent that the clip comes into contact with the rotor, unusual noise (squeak) is produced. If such a noise is noticed, replace the pads.

Inspect for wear and damage, and correct or replace if

Disc Code	Brake disc thickness mm (in)			
	Front		Rear	
	For 13" wheels	For 14" & 15" wheels	Solid	Ventilated
Standard	18 (0.71)	24 (0.94)	10 (0.39)	18 (0.71)
Wear limit	16 (0.63)	22 (0.87)	8.5 (0.335)	16 (0.63)

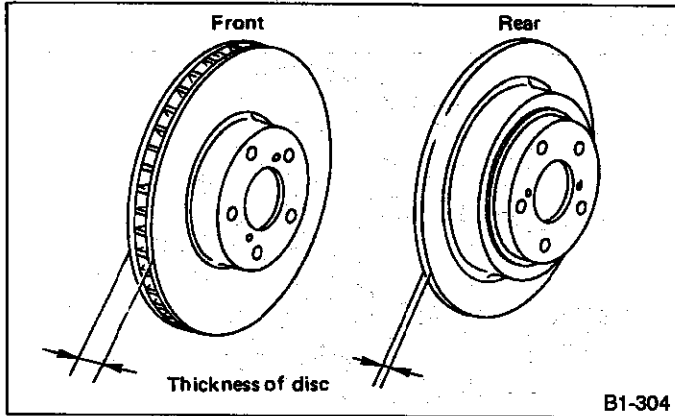


Fig. 51

Disc rotor runout:
Limit: 0.10 mm (0.0039 in)

Measure the disc rotor runout at a point less than 5 mm (0.20 in) from the outer periphery of the rotor.

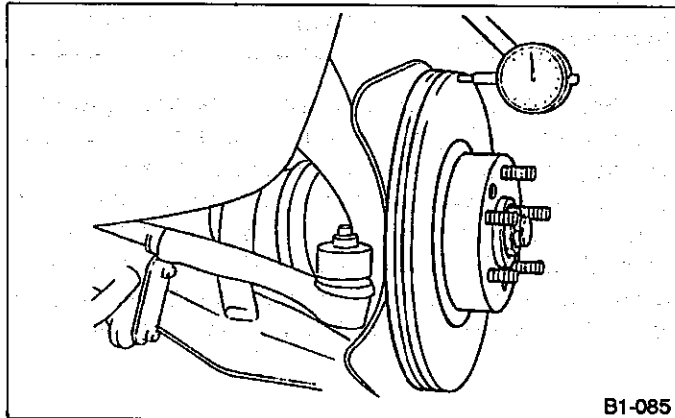


Fig. 52

2. FRONT AND REAR AXLE BOOTS

Inspect front and rear axle boots for deformation, damage or failure. If faulty, replace them with new ones.

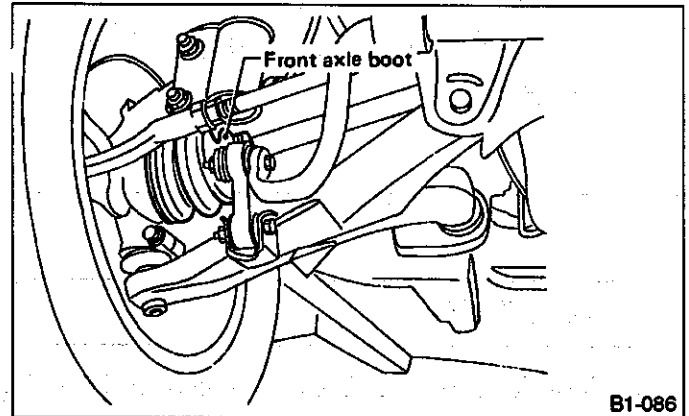


Fig. 53

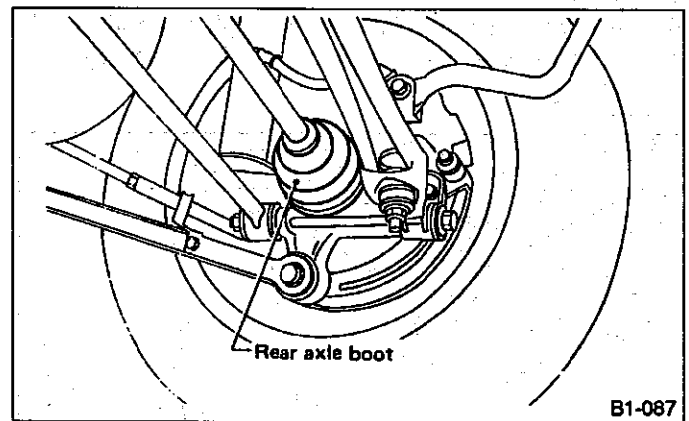


Fig. 54

13. Brake Linings and Drums

MAINTENANCE INTERVAL					
[Number of months or km (miles) whichever occurs first]					
Months		12	24	36	48
x1,000 km	1.6	25	50	75	100
x1,000 miles	1	15	30	45	60

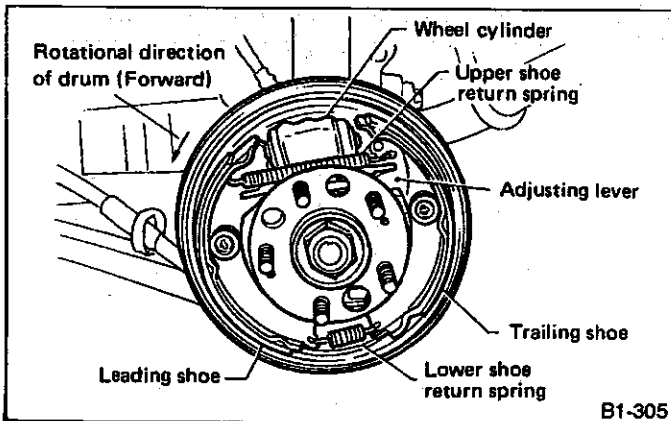
A: INSPECTION

1. REAR DRUM BRAKE

- 1) Remove brake drum, and check that there is no fluid leakage from wheel cylinder. If there is fluid leakage from wheel cylinder, replace it.
- 2) Inspect brake shoes for damage or deformities and check brake linings for wear.

Always replace both leading and trailing brake shoes for the left and right wheels at the same time.

Brake lining thickness excluding brake metal:
 Standard: 4.1 mm (0.161 in)
 Wear limit: 1.5 mm (0.059 in)



B1-305

Fig. 55

Check brake drum for wear, dents or other damage. If the inside surface of brake drum is streaked, correct the surface with emery cloth (#200 or more). If it is unevenly worn, tapered, or the outside surface of brake drum is damaged, correct or replace it.

Brake drum inside diameter:
 Standard: 228.6 mm (9 in)
 Wear limit: 230.6 mm (9.08 in)

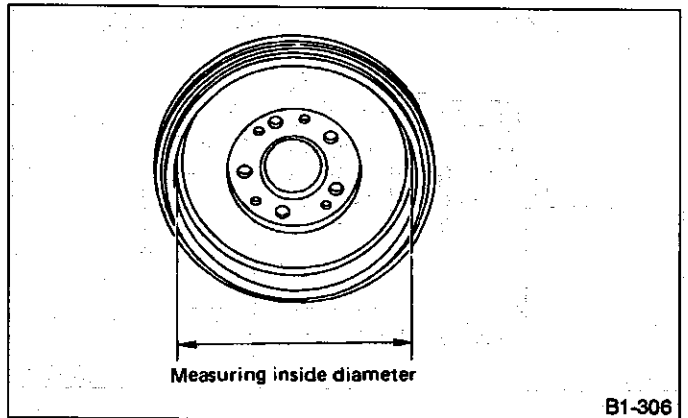


Fig. 56

If deformation or wear on back plate, shoe etc. is notable, replace the effected parts.

2. PARKING BRAKE

Inspect brake linings and drums of both sides of the rear brake at the same time by removing brake drums.
 1) Inspect brake shoes for damage or deformities and check brake linings for wear.

Always replace both primary and secondary brake shoes for the left and right wheels at the same time.

Brake lining thickness excluding back metal:
 Standard: 3.2 mm (0.126 in)
 Wear limit: 1.5 mm (0.059 in)

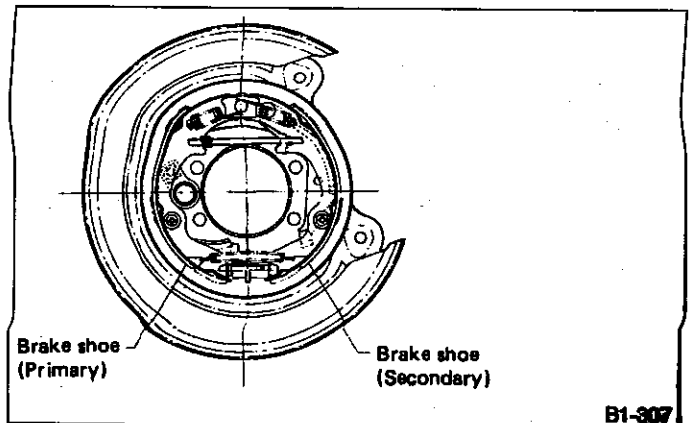


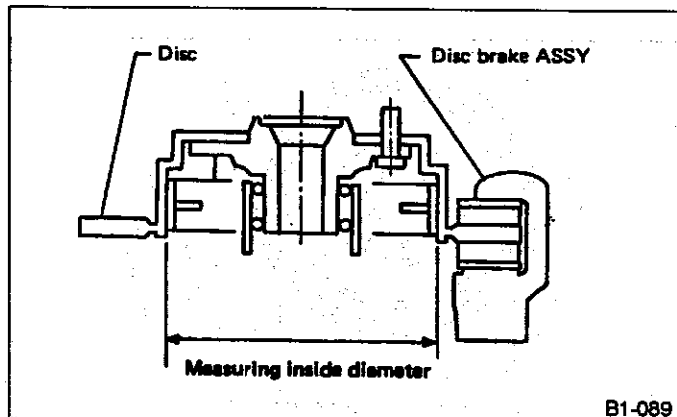
Fig. 57

2) Check brake drum for wear, dents or other damage. If the inside surface of brake drum is streaked, correct the surface with emery cloth (#200 or more). If it is unevenly worn, tapered, or the outside surface of brake drum is damaged, correct or replace it.

Brake drum inside diameter:

Standard: 170 mm (6.69 in)

Wear limit: 171 mm (6.73 in)



B1-089

Fig. 58

3) If the deformation or wear of back plate, shoe, etc. are notable, replace them.

4) When the shoe return spring tension is excessively weakened, replace it, taking care to identify upper and lower springs.

B: ADJUSTMENT

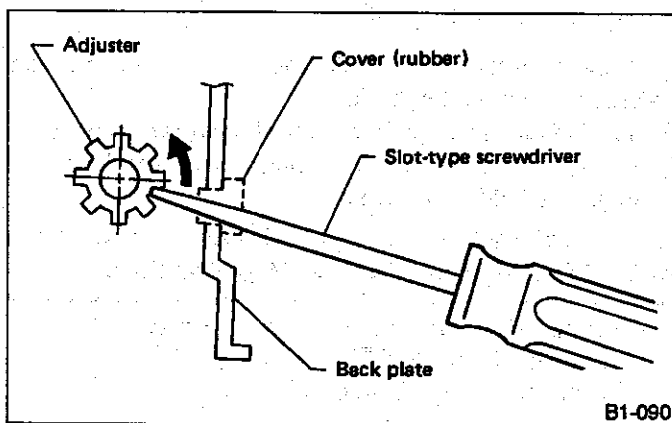
1. REAR DRUM BRAKE

The main brake is adjusted automatically, and so there is no need to adjust it.

2. PARKING BRAKE

For rear disc brake, adjust parking brake after bleeding the air.

- 1) Remove rear cover (rubber) installed at back plate.
- 2) Turn adjuster toward allow mark (upward) until it is locked slightly, by using slot-type screwdriver as shown in illustration below.



B1-090

Fig. 59

- 3) Turn back (downward) adjuster 3 to 4 notches.
- 4) Install cover (rubber) at original position correctly.

14. Inspect Brake Lines and Check Operation of Parking and Service Brake System

MAINTENANCE INTERVAL [Number of months or km (miles) whichever occurs first]					
Months		12	24	36	48
x1,000 km	1.6	25	50	75	100
x1,000 miles	1	15	30	45	60
		P	P	P	P

A: INSPECTION

1. BRAKE LINE

1) Check scratches, swelling, corrosion and/or traces of fluid leakage on brake hoses or pipe joints.

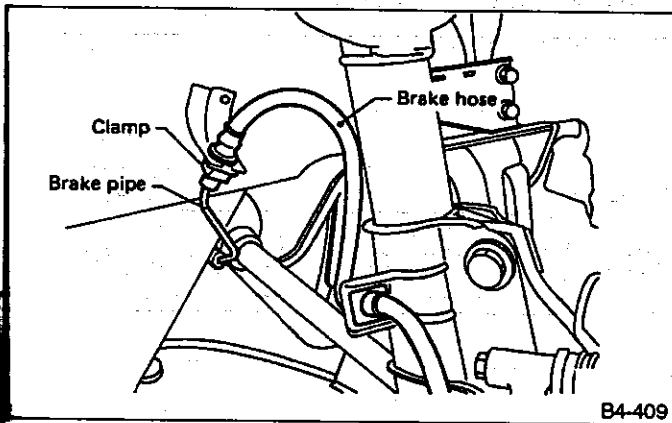


Fig. 60

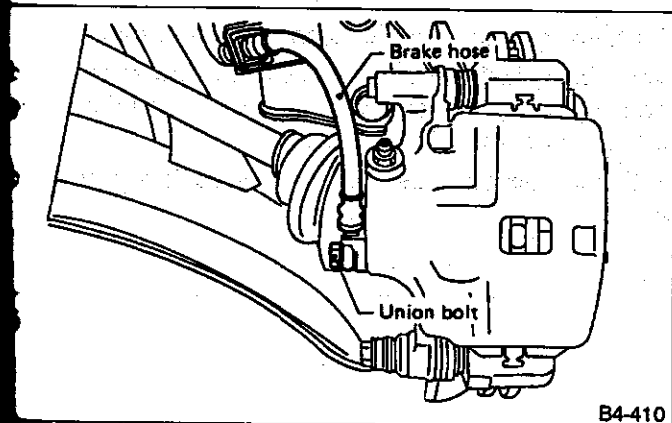


Fig. 61

Check the possibility of adjacent parts interfering with brake pipes/hoses during driving, and loose connections/clamps.

Check any trace of fluid leakage, scratches, etc. on master cylinder, wheel cylinder, pressure control valve and hill-holder.

When the brake fluid level in the reservoir tank is lower than the specified limit, the brake fluid warning light on the instrument panel will come on.

B: CHECKING

1. SERVICE BRAKE

1) Check the free play of brake pedal with a force of less than 10 N (1 kg, 2 lb).

Brake pedal free play:

1.0 — 3.0 mm (0.039 — 0.118 in)

If the free play is out of specifications above, adjust the brake pedal as follows:

- (1) Be sure engine is off. (No vacuum is applied to brake booster.)
- (2) There should be play between brake booster clevis and pin at brake pedal installing portion. (Depress brake pedal pad with a force of less than 10 N (1 kg, 2 lb) to a stroke of 1.0 to 3.0 mm (0.039 to 0.118 in).

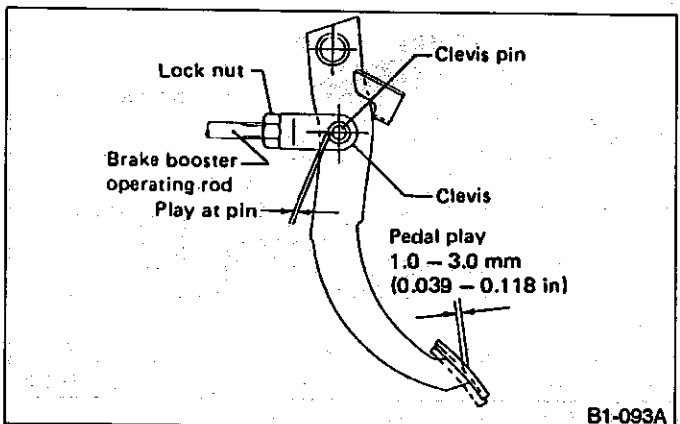


Fig. 62

(3) Depress the surface of brake pad by hand.

(4) If there is no free play between clevis pin and clevis, loosen lock nut for operating rod and adjust operating rod by turning in the direction that shortens it.

2) Measure the distance between brake pedal and floor when the pedal is depressed with a force of approximately 294 N (30 kg, 66 lb).

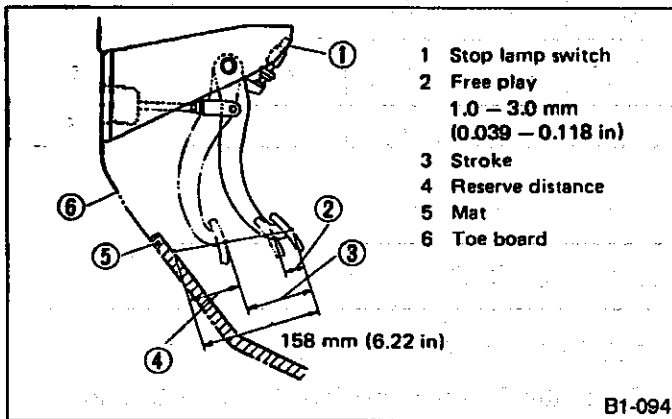
Brake pedal reserve distance:**More than 67 mm (2.64 in)/294 N (30 kg, 66 lb)**

Fig. 63

3) Check to see if air is in the hydraulic brake line by the feel of pedal operation. If air appears to exist in the line, bleed it from the system.

4) Check for even operation of all brakes, using a brake tester or by driving the vehicle for a short distance on a straight road.

2. PARKING BRAKE SYSTEM

- 1) Remove front console cover.
- 2) Remove rear console cover.
- 3) Adjust parking brake lever by turning adjuster (double nut) until parking brake lever stroke is set at 7 to 8 notches with operating force of 196 N (20 kg, 44 lb).

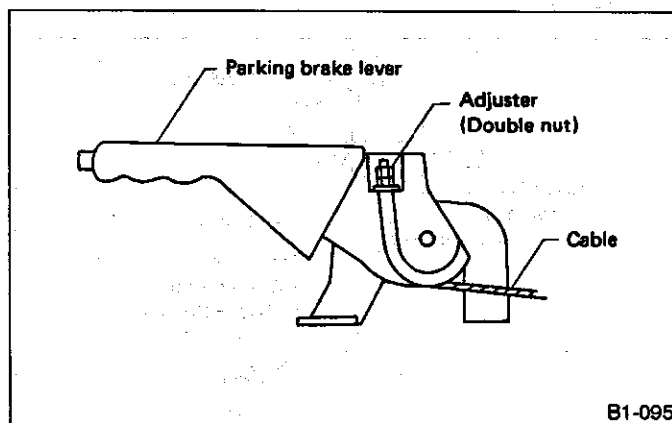


Fig. 64

3. BRAKE SERVO SYSTEM

1) With the engine off, depress the brake pedal several times applying the same pedal force: Make sure the travel distance should not change.

2) With the brake pedal depressed, start the engine: Make sure the pedal should move slightly toward the floor.

3) With the brake pedal depressed, stop the engine and keep the pedal depressed for 30 seconds: Make sure the pedal height should not change.

4) Check valve is built into vacuum hose. Disconnect vacuum hose to inspect function of check valve. Blow air into vacuum hose from its brake booster side end: Air must flow out of engine side end of hose. Next blow air into hose from engine side: Air should not flow out of hose.

Replace both check valve and vacuum hose if check valve is faulty. Engine side of vacuum hose is indicated by marking "ENGINE" as shown.

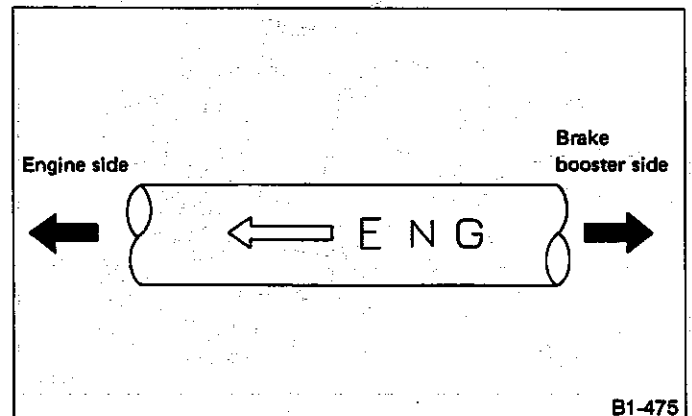


Fig. 65

5) Check vacuum hose for cracks or other damage.

When installing the vacuum hose on the engine and brake booster, do not use soapy water or lubricating oil on their connections.

6) Check vacuum hose to make sure it is tight and secure.

15. Clutch and Hill-holder System

MAINTENANCE INTERVAL [Number of months or km (miles) whichever occurs first]					
Months		12	24	36	48
x1,000 km	1.6	25	50	75	100
x1,000 miles	1	15	30	45	60

A: INSPECTION AND ADJUSTMENT

1. MECHANICAL APPLICATION TYPE

1) Inspect free play of clutch pedal by operating pedal by hand.
If it is out of the specified value, adjust it by turning adjusting nut on engine side of clutch cable at release fork.

Standard free play:

- At clutch pedal
10 — 20 mm (0.39 — 0.79 in)
- At center of cable on clutch release fork
3 — 4 mm (0.12 — 0.16 in)

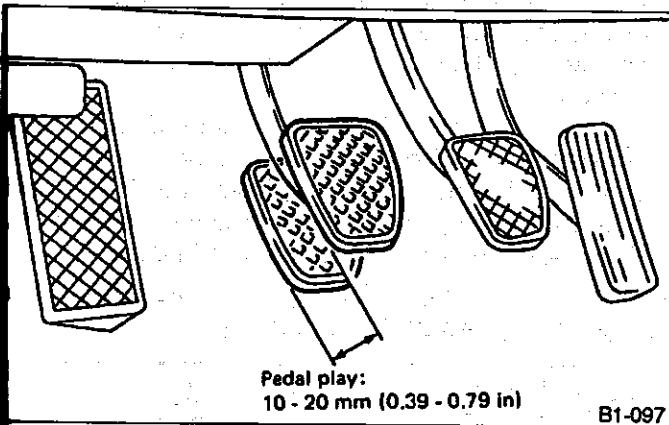


Fig. 66

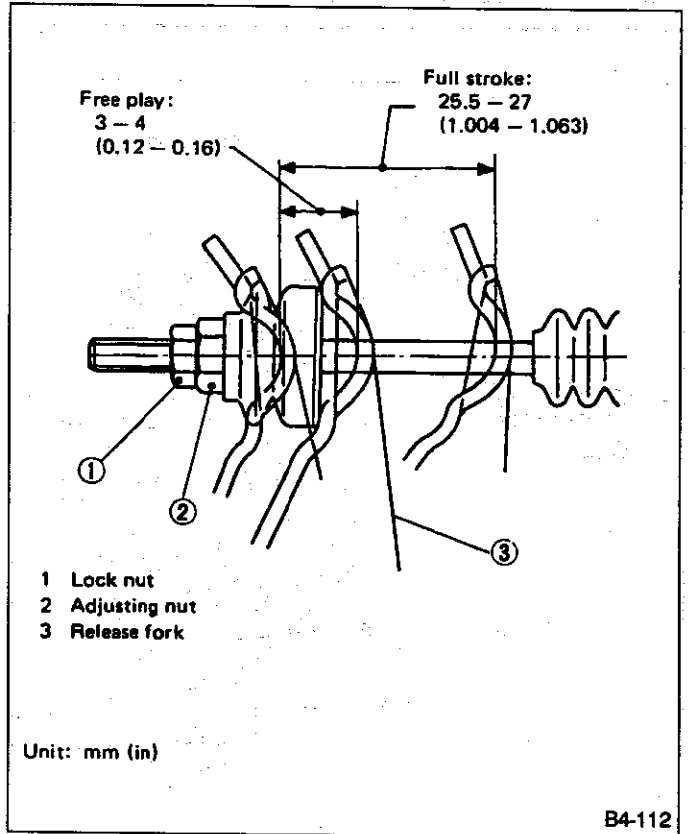


Fig. 67

Lock nut tightening torque :

5.4 — 9.3 N·m (0.55 — 0.95 kg-m, 4.0 — 6.9 ft-lb)

- a. When replacing clutch cable with a new one and/or making clutch pedal free play adjustment, make adjustment of hill-holder system without fail as follows.
- b. After replacing clutch cable and/or pressure hold valve (PHV) cable with a new one, depress clutch pedal about thirty (30) times as a running-in operation prior to this adjustment.

B: INSPECTION AND ADJUSTMENT**2. HYDRAULIC APPLICATION TYPE**

1) Inspect free play of clutch pedal by operating pedal by hand.

If it is out of the specified value, loosen lock nut for push rod and adjust push rod by turning in the direction that shortens or lengthens it.

Standard of free play:

3 — 15 mm (0.12 — 0.59 in)

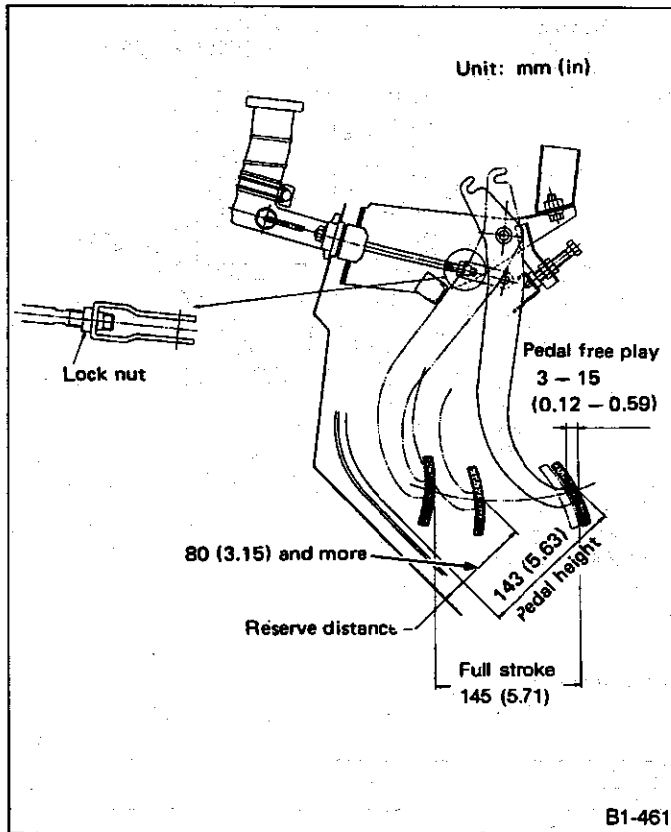


Fig. 68

Tightening torque (Adjusting nut):

9 — 11 N·m (0.9 — 1.1 kg·m, 6.5 — 8.0 ft·lb)

2) Check the fluid level using the scale on the outside of the clutch master cylinder tank. If the level is below "MIN", add clutch fluid to bring it up to "MAX".

Recommended clutch fluid:

FMVSS No. 116, fresh DOT3 or DOT4 brake fluid

- a. Avoid mixing different brands of brake fluid to prevent degradation of the fluid.
- b. Be careful not to allow dirt or dust to get into the reservoir tank.
- c. Use fresh DOT3 or DOT4 brake fluid when refilling fluid.

3. HILL-HOLDER

1) Confirm stopping and starting performance by activating hill-holder on an uphill road of 3° or higher inclination.

- (1) If vehicle does not stop;
Tighten adjusting nut of PHV cable.

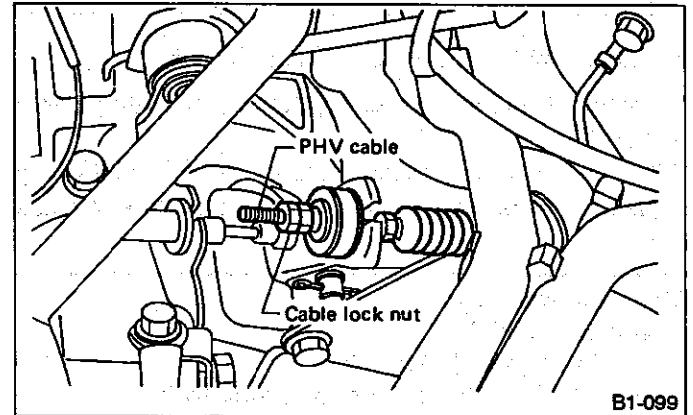


Fig. 69

- (2) If vehicle does not start properly;
 - Case A — When hill-holder is released later than engagement of clutch (engine tends to stall): Loosen adjusting nut gradually until smooth starting is enabled.
 - Case B — When hill-holder is released earlier than engagement to clutch (vehicle slips down slightly): Tighten adjusting nut so that hill-holder is released later than engagement of clutch (status in Case A). Then make adjustment the same as in Case A.

a. Whenever turning adjusting nut, hold inner cable with pliers to prevent it from turning.

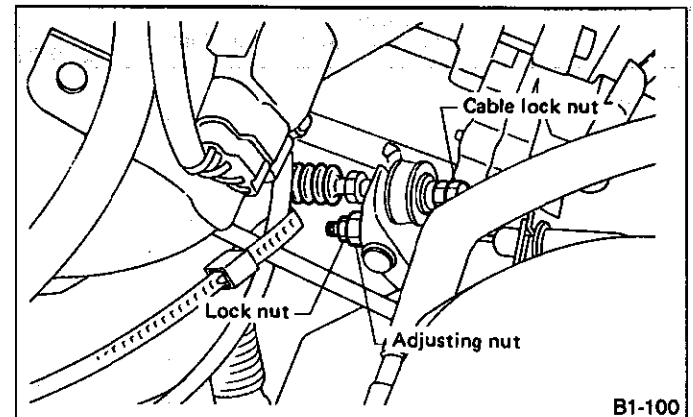


Fig. 70

b. Replace pressure hold valve (PHV), return spring of PHV or PHV cable with new ones, if they are defective and/or damaged.

2) Make sure that the automatic adjuster is operating.

• Check if the cable is able to be pulled out as shown in the figure below.

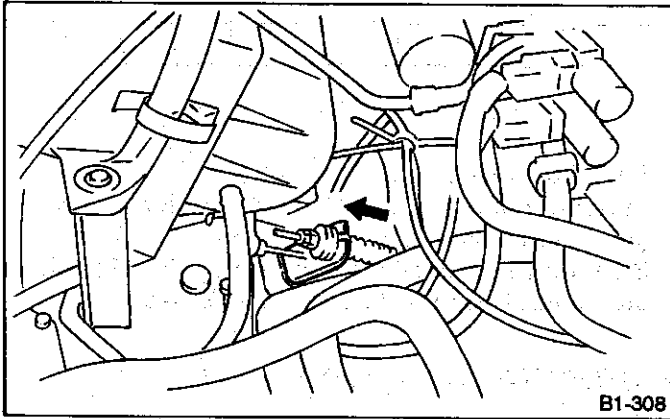


Fig. 71

16. Steering and Suspension System

A: INSPECTION

1. STEERING WHEEL

- 1) Set steering wheel in a straight-ahead position, and check wheel spokes to make sure they are correctly set in their specified positions.
- 2) Lightly turn steering wheel to the left and right to determine the point where front wheels start to move. Measure the distance of the movement of steering wheel at the outer periphery of wheel.

Steering wheel free play:
0 — 17 mm (0 — 0.67 in)

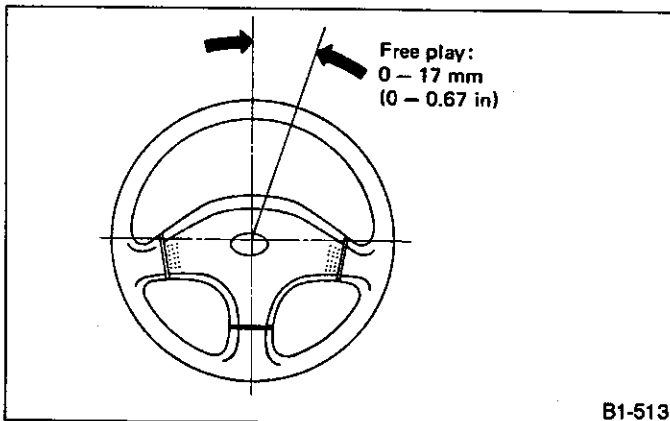


Fig. 72

- 3) Move steering wheel vertically toward the shaft to ascertain if there is play in that direction.

Maximum permissible play:
0.5 mm (0.020 in)

- 4) Drive vehicle and check the following items during operation.

(1) **Steering force**

The effort required for steering should be smooth and even at all points, and should not vary.

(2) **Pull to one side**

Steering wheel should not be pulled to either side while driving on a level surface.

MAINTENANCE INTERVAL					
[Number of months or km (miles) whichever occurs first]					
Months		12	24	36	48
x1,000 km	1.6	25	50	75	100
x1,000 miles	1	15	30	45	60

(3) **Wheel runout**

Steering wheel should not show any sign of runout.

(4) **Return factor**

Steering wheel should return to its original position after it has been turned and then released.

2. STEERING SHAFT JOINT

- 1) When steering wheel free play is excessive, disconnect universal joint of steering shaft and check it for any play and yawing torque (at the point of the crossing direction). Also inspect for any damage to sealing or worn serrations.

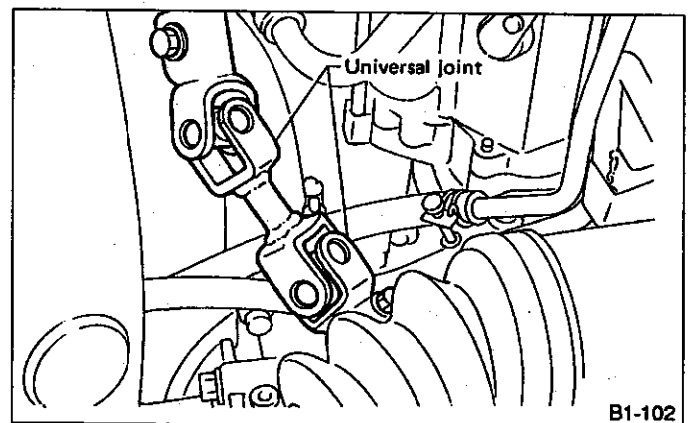


Fig. 73

If the joint is loose, retighten the mounting bolts to the specified torque.

Tightening torque:

21 — 26 N·m (2.1 — 2.7 kg·m, 15 — 20 ft·lb)

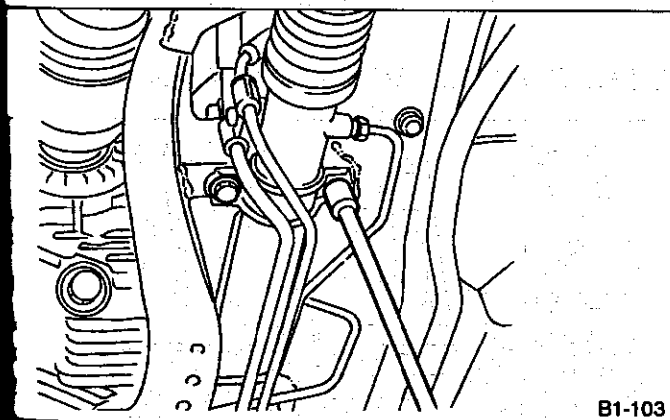
3. GEARBOX

1) With wheels placed on a level surface, turn steering wheel 90° in both the left and right directions.

While wheel is being rotated, reach under vehicle and check for looseness in gearbox.

Tightening torque:

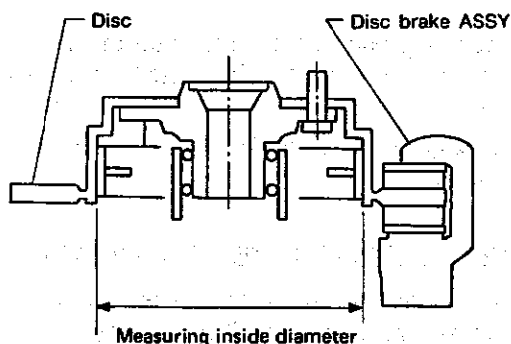
47 — 71 N•m (4.8 — 7.2 kg-m, 35 — 52 ft-lb)



B1-103

Fig. 74

Check boot for damage, cracks or deterioration.



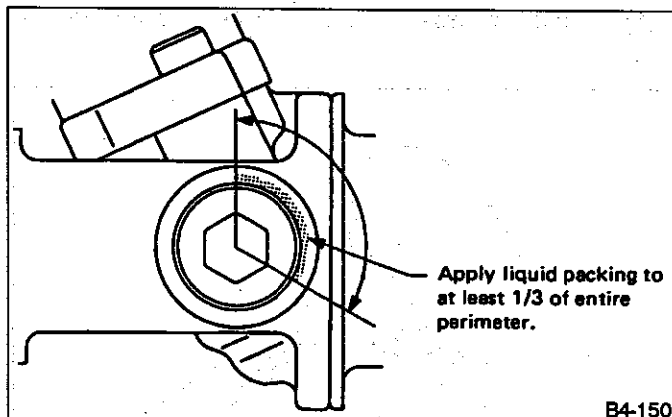
B1-104

Fig. 75

With vehicle on a level surface, quickly turn steering wheel to the left and right.

While steering wheel is being rotated, check the gear backlash. If any unusual noise is noticed, adjust the gear backlash in the following manner.

- (1) Tighten adjusting screw to 5 N•m (0.5 kg-m, 3.6 ft-lb) and then loosen. Repeat this operation twice.
- (2) Retighten adjusting screw to 5 N•m (0.5 kg-m, 3.6 ft-lb) and back off 30°.
- (3) Apply liquid packing to at least 1/3 of entire perimeter of adjusting screw thread.



B4-150

Fig. 76

(4) Install lock nut. While holding adjusting screw with a wrench, tighten lock nut using SPANNER (926230000).

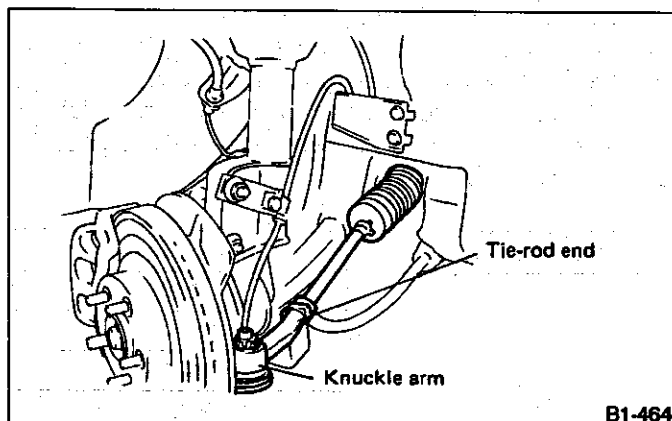
Tightening torque (Lock nut):

29 — 49 N•m (3.0 — 5.0 kg-m, 22 — 36 ft-lb)

Hold the adjusting screw with a wrench to prevent it from turning while tightening the lock nut.

4. TIE-ROD

- 1) Check tie-rod and tie-rod ends for bends, scratches or other damage.
- 2) Check connections of knuckle ball joints for play, inspect for damage on dust seals, and check the free play of ball studs.
- 3) Make sure that the cotter pin is installed correctly in the castle nut of the tie-rod end.



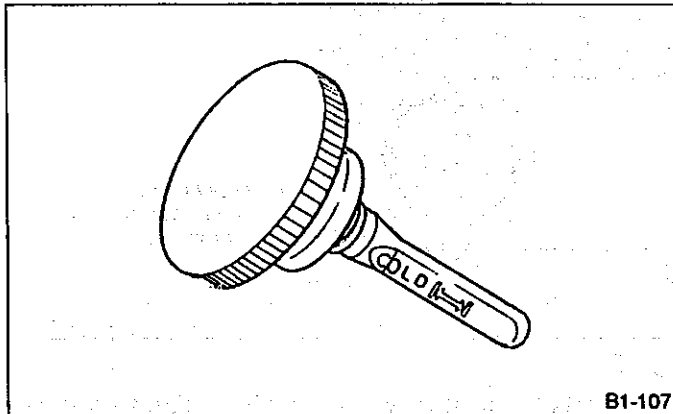
B1-464

Fig. 77

5. POWER STEERING FLUID LEVEL

- 1) Place vehicle with engine "off" on the flat and level surface.
- 2) Check the fluid level by removing filler cap of pump.

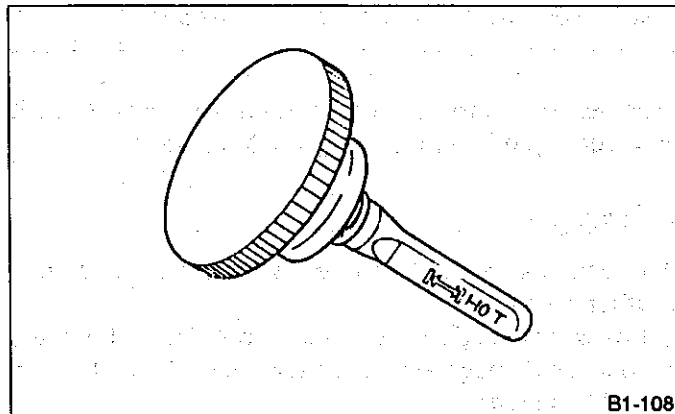
(1) Check at temperature 21°C (70°F) of fluid temperature.



B1-107

Fig. 78

(2) Check at temperature 60°C (140°F) of fluid temperature.



B1-108

Fig. 79

3) Fluid level should be maintained in the each specified range on the indicator of filler cap.
 If fluid level is at lower point or below, add fluid to keep the level in the specified range of indicator.
 If fluid level is at upper point or above, drain fluid to keep the level in the specified range of indicator by using a syringe or the like.

Recommended fluid	Manufacturer
ATF Dexron II	B.P.
	CALTEX
	CASTROL
	MOBIL
	SHELL
	TEXACO

Fluid capacity:
 0.7 ℓ (0.7 US qt, 0.6 Imp qt)

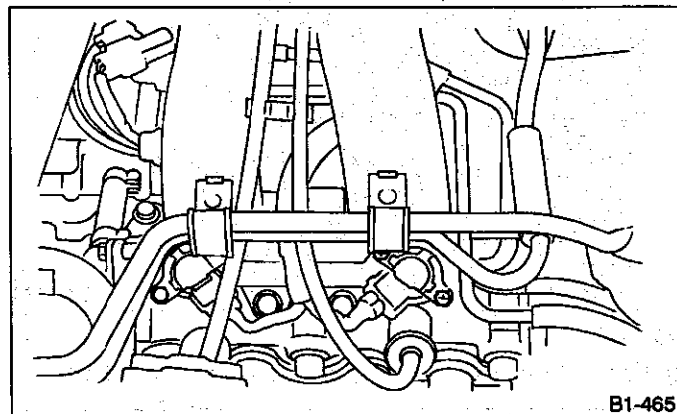
6. POWER STEERING FLUID FOR LEAKS

Inspect the underside of oil pump and gearbox for power steering system, hoses, piping and their couplings for fluid leaks.

If fluid leaks are found, correct them by retightening their fitting bolts (or nuts) and/or replacing their parts.

- a. Wipe the leakage fluid off after correcting fluid leaks, or a wrong diagnosis is taken later.
- b. Also pay attention to clearances between hoses (or pipings) and other parts when inspecting fluid leaks.

7. HOSES OF OIL PUMP FOR DAMAGES



B1-465

Fig. 80

Check pressure hose and return hose of oil pump for crack, swell or damage. Replace the hoses with new ones if necessary.

Prevent hoses from revolving and/or turning when installing hoses.

8. POWER STEERING PIPES FOR DAMAGE

Check power steering pipes for corrosion and damage. Replace pipes with new ones if necessary.

9. GEARBOX BOOTS

Inspect both sides of gearbox boots as follows, and correct the defects if necessary.

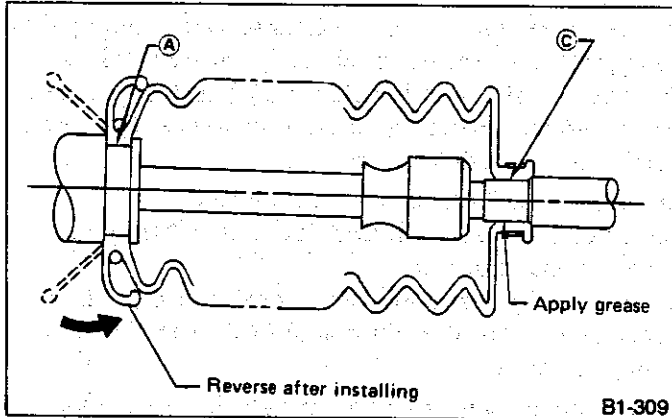


Fig. 81

- 1) A and C position of gearbox boot are fitted correspondingly in A and C grooves of gearbox and the rod.
- 2) Clips are fitted outside of A and C positions of boot.
- 3) Boot does not have crack, hole.

Rotate C position of gearbox boot against twist of it produced by adjustment of toe-in, etc.

10. FITTING BOLTS AND NUTS

Inspect fitting bolts and nuts of oil pump and bracket for looseness, and retighten them if necessary.

Inspect and/or retighten them when engine is cold.

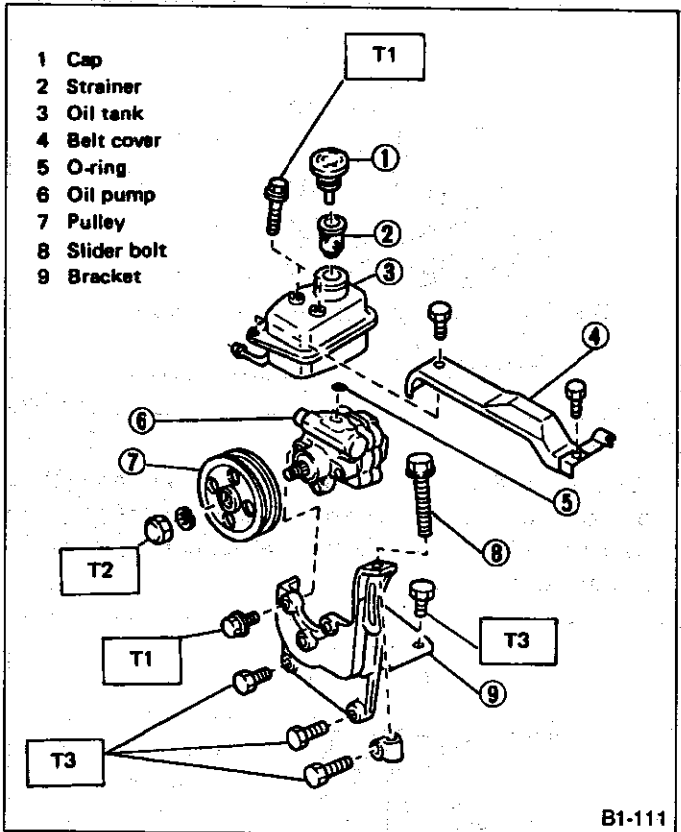


Fig. 82

Tightening torque: N·m (kg-m, ft-lb)

- T1: 18 — 23 (1.8 — 2.3, 13 — 17)
- T2: 42 — 62 (4.3 — 6.3, 31 — 46)
- T3: 20 — 24 (2.0 — 2.4, 14 — 17)

11. SUSPENSION SYSTEM

Care should be taken not to apply paint, undercoating agent, anti-corrosive wax, etc. to the following parts of air-suspension equipped models while refinishing the undercarriage.

- (1) Diaphragm and rolling surfaces
- (2) Air suspension compressor and dryer assembly

1) Play of front ball joint Inspect every 25,000 km (15,000 miles) or 12 months, whichever occurs first.

- (1) Jack up vehicle until front wheels are off ground.
- (2) Next, grasp bottom of tire and move it in and out. If relative movement is observed between brake disc cover and end of transverse link, ball joint may be excessively worn.

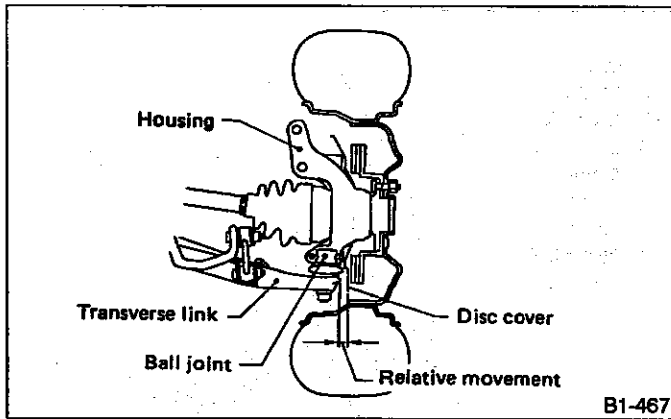


Fig. 83

(3) Next, grasp end of transverse link and move it up and down. Relative movement between housing and transverse link boss indicates ball joint may be excessively worn.

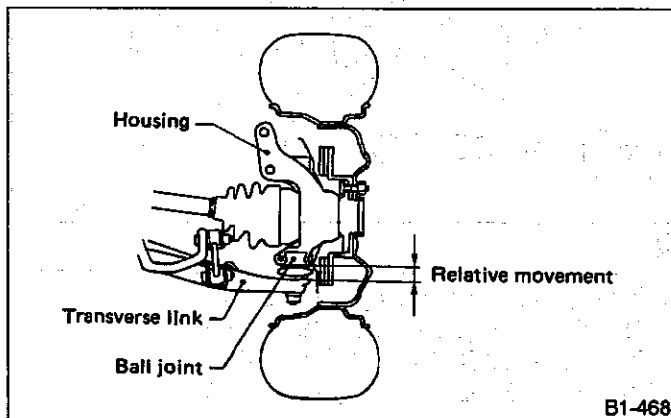


Fig. 84

(4) If relative movement is observed in tests (2) and (3) above, remove and inspect ball joint according to chapter 4-1. If looseness exceeds standard, replace ball joint.

2) Damage of dust seal Inspect every 25,000 km (15,000 miles) or 12 months, whichever occurs first.

Visually inspect ball joint dust seal. If it is damaged, remove ball joint as instructed in chapter 4-1 and measure looseness of ball joint.

(1) When looseness exceeds standard value, replace ball joint.

(2) When looseness is less than standard value, wipe off old grease, apply the proper amount [about 3 g (0.11 oz)] of designated grease (SUNLIGHT 2, P/N 003602010), and install a new dust seal.

When transverse link ball joint has been removed or replaced, check toe-in (or side slip) of front wheel. If front wheel toe-in (or side slip) is not at specified value, adjust according to chapter 4-1 so that toe-in conforms to service standard.

3) Transverse link's liquid-filled bushing

Check oil leaks at or around liquid-filled bushing. If oil leaks, replace bushing.

4) Wheel alignment and ground clearance Inspect every 50,000 km (30,000 miles) or 24 months, whichever occurs first.

(1) Unload cargoes and set vehicle in curb weight (empty) condition.

(2) Then, check ground clearance of front and rear suspensions to ensure that they are within specified values.

(Adjusting procedure) — Ground clearance

When ground clearance is out of standard, visually inspect following components and replace deformed parts.

- Suspensions components [Front: strut assembly, crossmember, transverse link, etc. Rear: shock absorber, lateral links, trailing link, etc.]

- Body parts to which suspensions are installed.

When no components are deformed, adjust ground clearance by replacing coil spring in the suspension whose ground clearance is out of standard.

(3) Check alignment of front suspension to ensure that following items conform to standard values provided in chapters 4-1 and 4-3.

- Toe-in (or side slip)
- Camber angle
- Caster angle
- Turning angle of tire

(Adjusting procedure) — Front suspension alignment

(a) Camber and caster angles are not adjustable. When camber or caster angle does not conform to standard value, visually inspect following components and replace deformed parts.

- Suspension components [Strut assembly, crossmember, transverse link, etc.]

- Body parts to which suspensions are installed.

(b) When toe-in (or side slip) is out of standard value, adjust by the method described in chapter 4-1 so that it conforms to service standard.

(c) When right-and-left turning angles of tire are out of standard, adjust to standard value by method described in chapter 4-3.

(4) Check alignment of rear suspension to ensure that following items are within standard values.

- Toe-in (or side slip)
- Camber angle

(Adjusting procedure) — Rear suspension alignment

When toe (or side slip) or camber angle does not conform to standard value, visually inspect parts listed below. If deformation is observed, replace damaged parts.

- Suspension components [Shock absorber, lateral links, trailing link, crossmember, etc.]
- Body parts to which suspensions are installed.

When no components are deformed, adjust alignment by the method described in chapter 4-1 so that it conforms to service standard.

5) Oil leakage of shock absorber Inspect every 50,000 km (30,000 miles) or 24 months, whichever occurs first.

Remove tire and visually inspect shock absorber for oil leakage as instructed in chapter 4-1. Replace shock absorber if oil leaks excessively.

6) Tightness of bolts and nuts Inspect every 50,000 km (30,000 miles) or 24 months, whichever occurs first. Check bolts shown below for looseness. Retighten bolts to specified torque. Further, check that cotter pin in place as shown below. If not, install new cotter pin.

FRONT

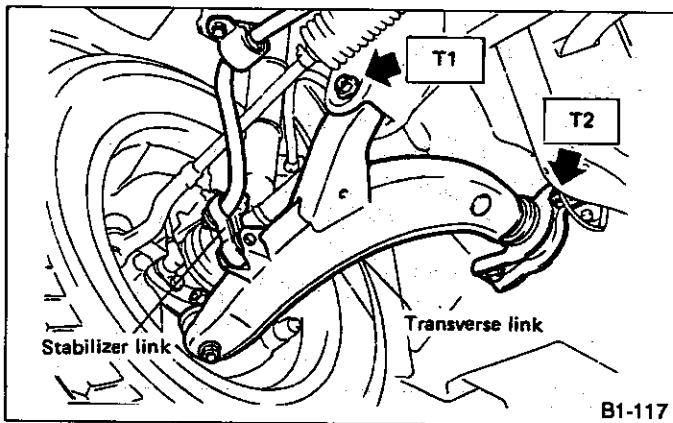


Fig. 85

REAR

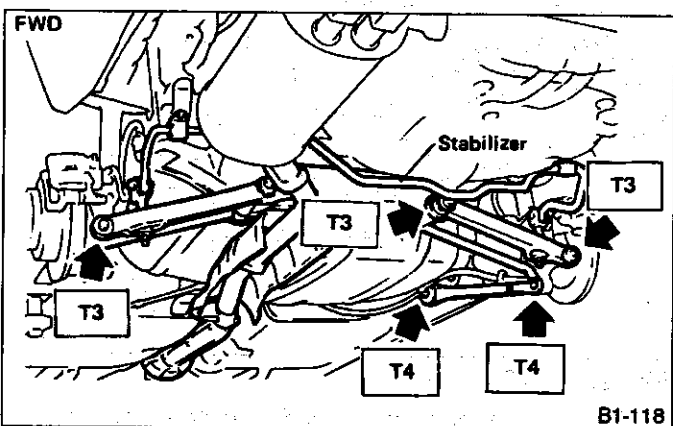


Fig. 86

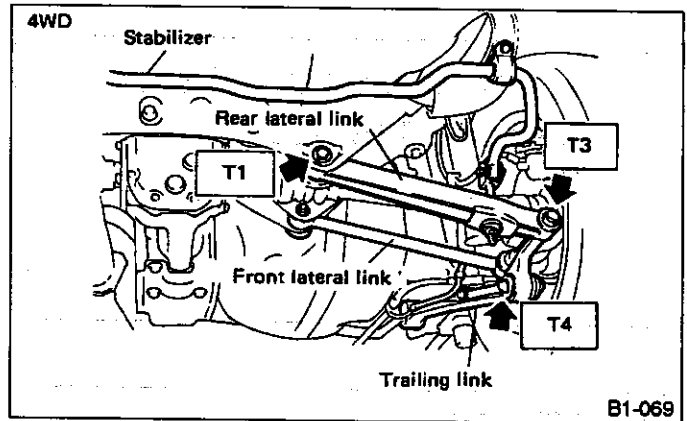


Fig. 87

Tightening torque: N·m (kg-m, ft-lb)

- T1: 83 — 113 (8.5 — 11.5, 61 — 83)
- T2: 196 — 294 (20 — 30, 145 — 217)
- T3: 118 — 157 (12 — 16, 87 — 116)
- T4: 98 — 127 (10 — 13, 72 — 94)

7) Dirt on and damage to rolling diaphragm of air suspension Inspect every 25,000 km (15,000 miles) or 12 months, whichever occurs first.

- (1) After loosening wheel nuts, jack up vehicle until all four wheels are off ground according to instructions in "Pre-Delivery Inspection." Remove tires.
- (2) Visually inspect rolling diaphragm. If dirty, remove dirt from diaphragm. Be careful not to damage diaphragms.
- (3) Visually inspect rolling diaphragm. Replace air suspension ASSY if damaged. However, replacement is not required if only fine scratches on diaphragm surface caused by sand. These do not present a problem.
- (4) Visually inspect rolling diaphragm for rust. If rusty, remove rust and touch up.

When touching up diaphragm, be careful paint does not adhere to diaphragm. (Lower jack after touch-up paint has dried completely.)

8) Damage to suspension parts

Check the following parts and the fastening portion of the car body for deformity or excessive rusting which impairs the suspension. Replace faulty parts. If minor rust formation, pitting, etc. are noted, remove rust and apply remedial anti-corrosion measures.

- (1) Front suspension
 - Transverse link
 - Crossmember
 - Strut (including air suspension)
- (2) Rear suspension
 - Crossmember
 - Lateral links
 - Trailing link
 - Strut (including air suspension)

17. Front and Rear Wheel Bearing Lubricant

MAINTENANCE INTERVAL [Number of months or km (miles) whichever occurs first]					
Months		12	24	36	48
x1,000 km	1.6	25	50	75	100
x1,000 miles	1	15	30	45	60
					(l)

A: INSPECTION

Inspect the condition of front and rear wheel bearing grease as follows:

1. FRONT WHEEL BEARING

- 1) Jack up the front of vehicle.
- 2) While holding front wheel by hand, swing it in and out to check bearing free play.
- 3) Loosen wheel nuts and remove front wheel.
- 4) If bearing free play exists in step 2) above, attach a dial gauge to hub and measure axial displacement in axial direction.

Service limit:

Straight-ahead position within 0.05 mm (0.0020 in)

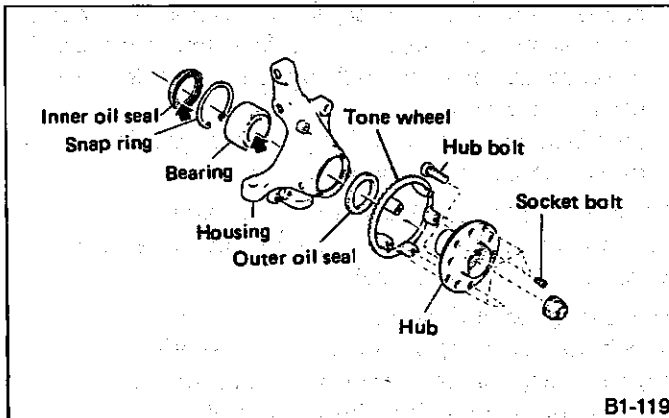


Fig. 88

- 5) Remove bolts and self-locking nuts, and extract transverse link from front crossmember.
- 6) While lightly hammering spring pin which secures D.O.J. to transmission spindle, remove it.
- 7) Extract D.O.J. from transmission spindle.
- 8) While supporting front drive shaft horizontally with one hand, turn hub with the other to check for noise or binding.

If hub is noisy or binds, disassemble front axle and check condition of oil seals, bearing, etc.

2. REAR WHEEL BEARING

- 1) Jack up the rear of vehicle.
- 2) While holding rear wheel by hand, swing it in and out to check bearing free play.
- 3) Loosen wheel nuts and remove rear wheel.
- 4) If bearing free play exists in step 2) above, attach a dial gauge to hub and measure axial displacement in axial direction.

Service limit:

Straight-ahead position within 0.05 mm (0.0020 in)

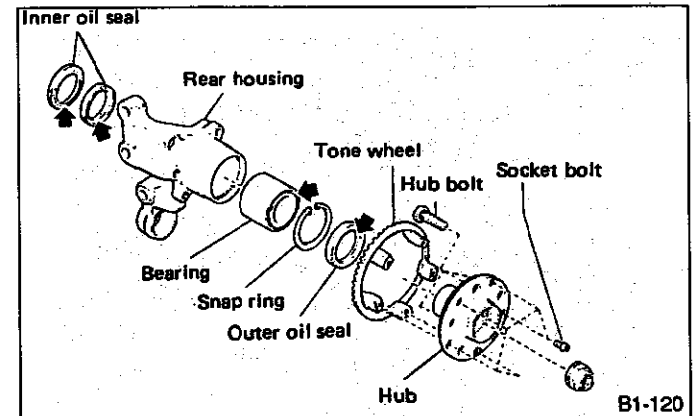


Fig. 89 4WD

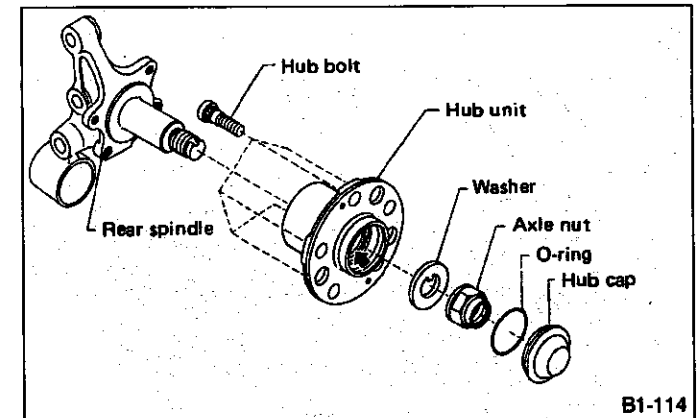


Fig. 90 FWD

- 5) Turn hub by hand to check for noise or binding. If hub is noisy or binds, disassemble front axle and check condition of oil seals, bearings, etc.

When the vehicle is a 4WD model, remove bolts and self-locking nuts, and remove front lateral link from crossmember.

Lightly hammer spring pin which secures D.O.J. to rear differential spindle, to remove it.

Extract D.O.J. from rear differential spindle. While supporting rear drive shaft horizontally with one hand, turn hub with the other hand to check for noise or binding.

If hub is noisy or binds, disassemble rear axle and check condition of oil seals, bearing, etc.

SUBARU®

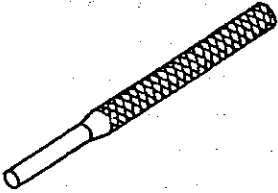
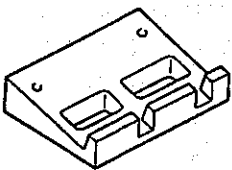
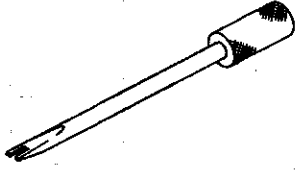
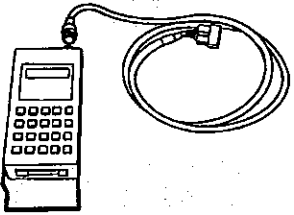
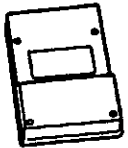
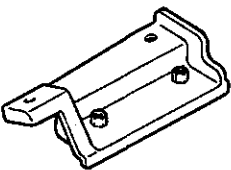
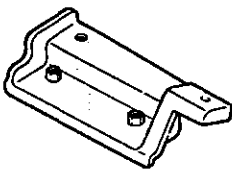

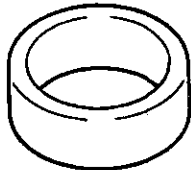
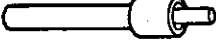

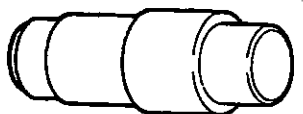
1992

**SERVICE
MANUAL**

	Page
1. Engine Tools	2
2. Manual Transmission and Differential Tools	5
3. Automatic Transmission and Differential Tools	10
4. Rear Wheel Drive System (4WD Models) Tools	17
5. Suspension Tools	19
6. Wheels and Axles Tools	21
7. Steering System Tools	23
8. Brakes Tools	25
9. Body Tools	25



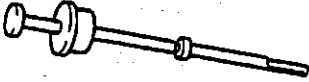
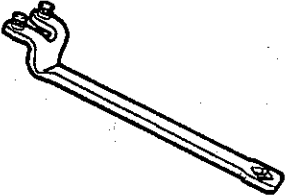
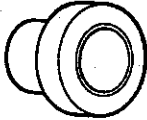
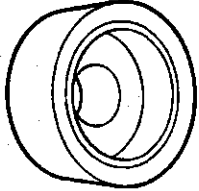


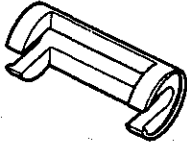



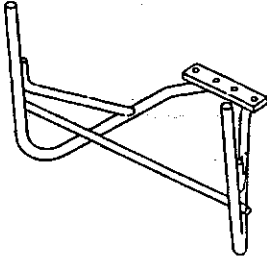
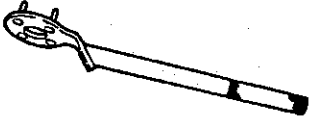
1. Engine Tools

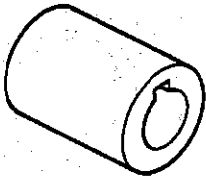
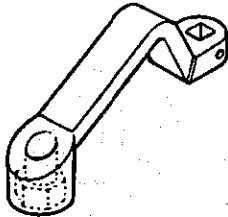
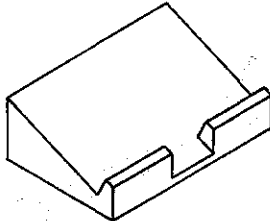
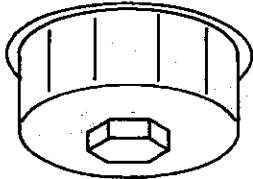
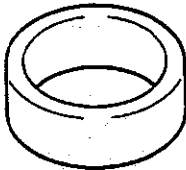
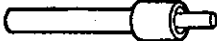
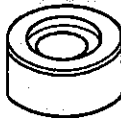


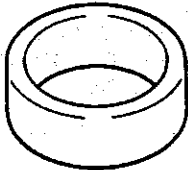
498017000	498267200	498297100	498307500
MAIN JET SCREWDRIVER	CYLINDER HEAD TABLE	IDLE ADJUST DRIVER	SELECT MONITOR KIT
Used to remove and install main jet on carburetor.	<ul style="list-style-type: none"> For replacing valve guides. Used to remove and install valve springs. 	Used to turn idle adjusting screw on carburetor.	Troubleshooting for electrical systems.
			
B1-314	B1-126	B1-315	B1-316
498348800★	498457000	498457100	498497100
CARTRIDGE	ENGINE STAND ADAPTER RH	ENGINE STAND ADAPTER LH	CRANKSHAFT STOPPER
Used with SELECT MONITOR KIT (498307500).	Used with ENGINE STAND (499817000).	Used with ENGINE STAND (499817000).	Used to stop rotation of flywheel when loosening and tightening crankshaft pulley bolt, etc.
			
B1-317	B1-127	B1-128	B1-129
498747100	498857100	499017100	499037100
PISTON GUIDE	VALVE OIL SEAL GUIDE	PISTON PIN GUIDE	CONNECTING ROD BUSHING REMOVER & INSTALLER
<ul style="list-style-type: none"> Used to install piston in cylinder. For 2200 cc engine. 	For press-fitting of intake and exhaust valve guide oil seals.	Used to install piston and connecting rod.	Used to remove and install connecting rod bushing.
			
B1-130	B1-131	B1-132	B1-133

★ Newly adopted tool.

SPECIAL TOOLS

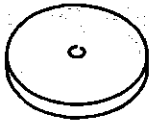

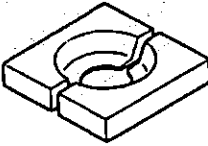




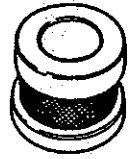

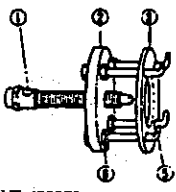

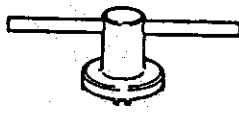
[0100] 1-6

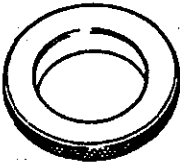
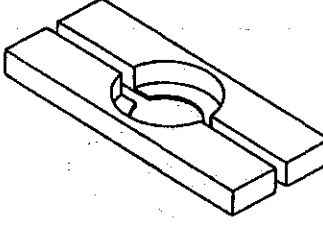
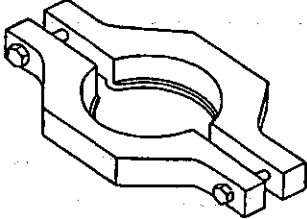




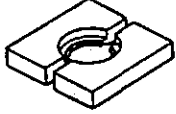
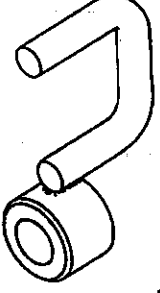
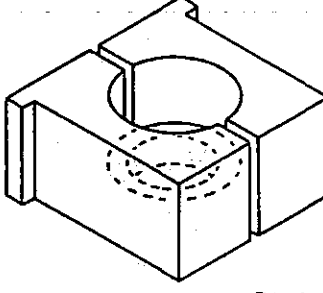

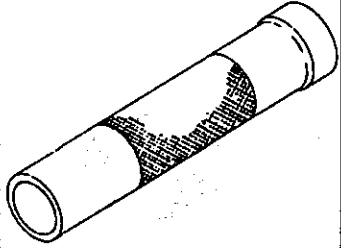
499097500	499207100	499587100	499587200
PISTON PIN REMOVER ASSY	CAMSHAFT SPROCKET WRENCH CP	CAMSHAFT OIL SEAL INSTALLER	CRANKSHAFT OIL SEAL INSTALLER
Used to remove piston pin	Used to remove and install camshaft sprocket.	<ul style="list-style-type: none"> • Used to install crankshaft oil seal. • Used with CAMSHAFT OIL SEAL GUIDE (499597000). 	<ul style="list-style-type: none"> • Used to install crankshaft oil seal. • Used with CRANKSHAFT OIL SEAL GUIDE (499597100).
			
B1-134	B1-135	B1-136	B1-137
499597000	499597100	499718000	499767000
CAMSHAFT OIL SEAL GUIDE	CRANKSHAFT OIL SEAL GUIDE	VALVE SPRING REMOVER	VALVE GUIDE ADJUSTER
<ul style="list-style-type: none"> • Used to install camshaft oil seal. • Used with CAMSHAFT OIL SEAL INSTALLER (499587100). 	<ul style="list-style-type: none"> • Used to install crankshaft oil seal. • Used with CRANKSHAFT OIL SEAL INSTALLER (499587200). 	Used to remove and install valve spring.	Used to install intake and exhaust valve guides.
			
B1-138	B1-139	B1-140	B1-141
499767200	499767400	499817000	499977000
VALVE GUIDE REMOVER	VALVE GUIDE REAMER	ENGINE STAND	CRANK PULLEY WRENCH CP
For removing valve guides.	For reaming valve guides.	<ul style="list-style-type: none"> • Stand used for engine disassembly and ASSY. Two pieces are needed. • Used with ENGINE STAND ADAPTER RH (498457000) & LH (498457100). 	Used to stop rotation of crankshaft pulley when loosening and tightening crankshaft pulley bolts.
			
B1-170	B1-171	B1-172	B1-142

<p>499987500</p>	<p>499990110</p>	<p>498267300★</p>	<p>498547000</p>
<p>CRANKSHAFT SOCKET</p>	<p>O₂ SENSOR SOCKET</p>	<p>CYLINDER HEAD TABLE</p>	<p>OIL FILTER WRENCH</p>
<p>Used to rotate crankshaft.</p>	<p>Used to remove and install oxygen (O₂) sensor.</p>	<ul style="list-style-type: none"> • For replacing valve guides. • Used to remove and install valve springs. • For DOHC engine. 	<p>Used to remove and install oil filter.</p>
 <p>B1-143</p>	 <p>B1-173</p>	 <p>B1-521</p>	 <p>C1-110</p>
<p>398744300★</p>	<p>498857200★</p>	<p>499767100★</p>	<p>499767300★</p>
<p>PISTON GUIDE</p>	<p>VALVE OIL SEAL GUIDE CP</p>	<p>VALVE GUIDE ADJUSTER</p>	<p>VALVE GUIDE REMOVER</p>
<ul style="list-style-type: none"> • Used to install piston in cylinder. • For 2000 cc engine. 	<ul style="list-style-type: none"> • For press-fitting of intake and exhaust valve guide oil seals. • For DOHC engine. 	<ul style="list-style-type: none"> • Used to install intake and exhaust valve guides. • For DOHC engine. 	<ul style="list-style-type: none"> • For removing valve guides. • For DOHC engine.
 <p>B1-130</p>	 <p>B1-131</p>	 <p>B1-141</p>	 <p>B1-170</p>
<p>499767500★</p>	<p>498747000★</p>		
<p>VALVE GUIDE REAMER</p>	<p>PISTON GUIDE</p>		
<ul style="list-style-type: none"> • For reaming valve guides. • For DOHC engine. 	<ul style="list-style-type: none"> • Used to install piston in cylinder. • For 1800 cc, 1600 cc engine. 		
 <p>B1-171</p>	 <p>B1-130</p>		

★ Newly adopted tool.

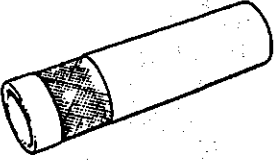
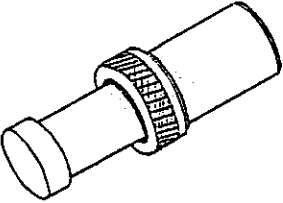
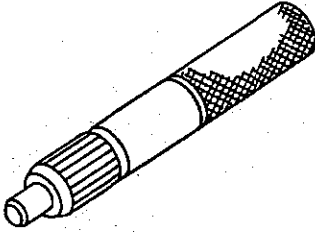
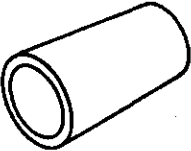
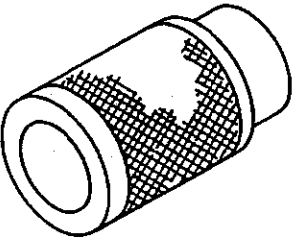
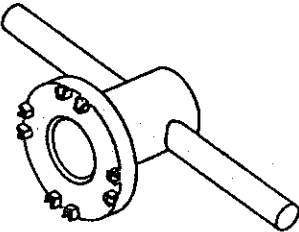
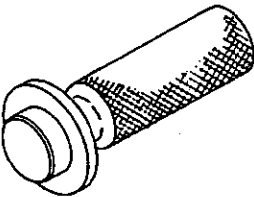
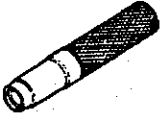
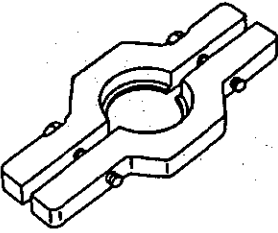
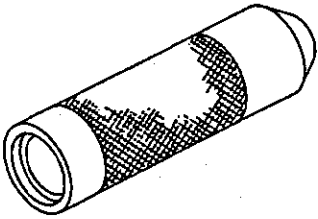
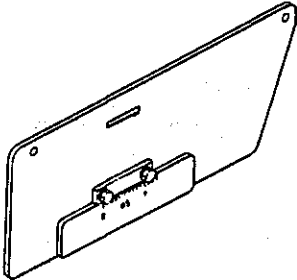

2. Manual Transmission and Differential Tools

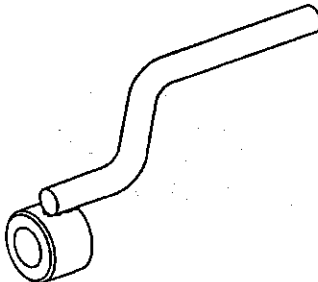
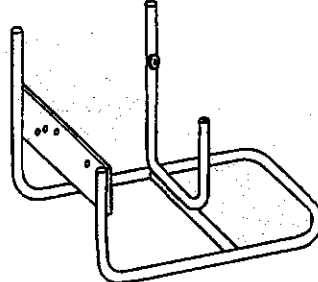

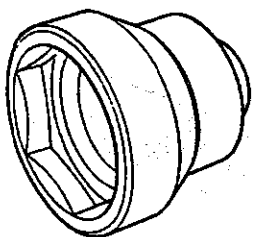


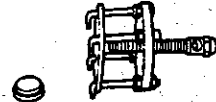

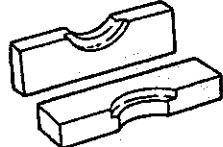


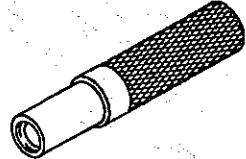
398497701	398507703	398517700	398663600
ADAPTER	DUMMY COLLAR	REPLACER	PLIERS
<ul style="list-style-type: none"> Used to install roller bearing onto differential case. Used with INSTALLER (499277100). 	Used to install input shaft holder oil seal.	Used when replacing ball bearing on rear drive shaft.	Used to remove and install input shaft snap ring.
			
B1-318	B1-319	B1-320	B1-321
398791600	398791700	399411700	399513600
REMOVER II	REMOVER II	INSTALLER	INSTALLER
Used to remove and install straight pin (5 mm).	Used to remove and install spring pin (6 mm).	Used to install reverse shifter rail arm.	Used to install extension rear oil seal. 4WD
			
B1-174	B1-175	B1-176	B1-177
399520105	399527700	399780104	399780111
SEAT	PULLER SET	WEIGHT	WRENCH
Used to install roller bearing (Differential).	Used to remove and install roller bearing (Differential).	Used when measuring preload on roller bearing.	Used to install differential side retainer.
	 <ol style="list-style-type: none"> 1 BOLT (899521412) 2 PULLER (399527702) 3 HOLDER (399527703) 4 ADAPTER (398497701) 5 BOLT (899520107) 6 NUT (021008000) 		
B1-322	B1-178	B1-179	B1-363

399790110	498077000	498077300	498147000
<p>INSTALLER</p>	<p>5TH DRIVEN GEAR REMOVER</p>	<p>CENTER DIFFERENTIAL BEARING REMOVER</p>	<p>DEPTH GAUGE</p>
<p>Used to remove and install roller bearing (Differential).</p>	<p>Used to remove 5th driven gear.</p>	<p>Used to remove center differential cover ball bearing.</p>	<p>Used to adjust main shaft axial end play.</p>
 <p style="text-align: right;">B1-325</p>	 <p style="text-align: right;">B1-180</p>	 <p style="text-align: right;">B1-144</p>	 <p style="text-align: right;">B1-181</p>
498247001	498247100	498427100	498517000
<p>MAGNET BASE</p> <ul style="list-style-type: none"> • Used to measure backlash between side gear and pinion, and hypoid gear. • Used with DIAL GAUGE (498247100). 	<p>DIAL GAUGE</p> <ul style="list-style-type: none"> • Used to measure backlash between side gear and pinion, and hypoid gear. • Used with MAGNET BASE (498247001). 	<p>STOPPER</p> <p>For securing the drive pinion shaft ASSY and driven gear ASSY when removing the drive pinion shaft ASSY lock nut.</p>	<p>REPLACER</p> <p>Used to remove drive pinion thrust plate and needle bearing race.</p>
 <p style="text-align: right;">B1-182</p>	 <p style="text-align: right;">B1-183</p>	 <p style="text-align: right;">B1-145</p>	 <p style="text-align: right;">B1-184</p>
498797100	498937000	498277000	498277100
<p>MAIN SHAFT STOPPER</p> <p>Used to remove and install transmission main shaft.</p>	<p>TRANSMISSION HOLDER</p> <p>Used to remove and install transmission main shaft lock nut.</p>	<p>INSTALLER</p> <p>Used to assemble needle bearing onto drive pinion shaft.</p>	<p>BUSH 1-2 INSTALLER</p> <p>Used to install 1st driven gear thrust plate and 1st-2nd driven gear bushing.</p>
 <p style="text-align: right;">B1-185</p>	 <p style="text-align: right;">B1-186</p>	 <p style="text-align: right;">B1-326</p>	 <p style="text-align: right;">B1-187</p>

SPECIAL TOOLS

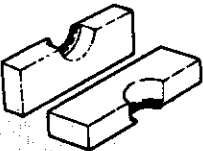


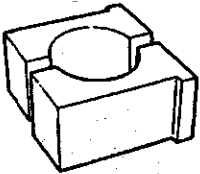
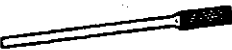
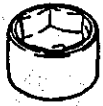
[0200]

499277200	499547300	499747100	499757001
INSTALLER	INSTALLER SET	CLUTCH DISC GUIDE	SNAP RING GUIDE
For press fitting the 2nd driven gear, roller bearings, & 5th driven gear onto the driven shaft.	Used to install viscous coupling needle bearing.	Used when installing clutch disc to flywheel.	Used to install snap ring (OUT 25). 4WD Dual-range
			
B1-188	B1-327	B1-189	B1-328
499757002	499787000	499797000	499827000
SNAP RING PRESS	WRENCH ASSY	OIL SEAL INSTALLER	PRESS
Used to install snap ring (OUT 25), and ball bearing (25 x 26 x 17).	Used to remove and install differential side retainer.	Used to install differential side retainer.	For installing speedometer oil seal when installing speedometer cable to transmission.
			
B1-190	B1-191	B1-192	B1-193
499857000	499877000	499917500	499927000
REMOVER ASSY	RACE 4-5 INSTALLER	DRIVE PINION GAUGE ASSY	HANDLE
Used to remove 5th driven gear.	<ul style="list-style-type: none"> • Used to install 4th needle bearing race and ball bearing onto transmission main shaft. • Used with REMOVER (899714110). 	Used to adjust drive pinion shim.	Used to remove and install transmission main shaft.
			
B1-194	B1-195	B1-196	B1-329

499927100	499937100	499987003	499987300
HANDLE	TRANSMISSION STAND	SOCKET WRENCH (35)	SOCKET WRENCH (35)
Used to fit transmission main shaft.	Stand used for transmission dis-assembly and ASSY.	Used to remove and install driven pinion lock nut and main shaft lock nut (4WD).	Used to remove and install driven gear ASSY lock nut.
 <p style="text-align: right;">B1-197</p>	 <p style="text-align: right;">B1-146</p>	 <p style="text-align: right;">B1-198</p>	 <p style="text-align: right;">B1-199</p>
899938600	899474100	899524100	899580100
HOLDER	EXPANDER	PULLER SET	INSTALLER
Used to disassemble and assemble gears onto transmission main shaft.	Used to remove and install snap ring.	Used to remove roller bearing (Differential). 1800 cc	Used when installing transmission main shaft, drive pinion and ball bearing (Rear drive shaft).
 <p style="text-align: right;">B1-330</p>	 <p style="text-align: right;">B1-331</p>	 <p style="text-align: right;">B1-332</p>	 <p style="text-align: right;">B1-333</p>
899714110	899754110	899754112	899824100
RETAINER	PRESS ASSY	PRESS	PRESS
For fixing transmission main shaft, drive pinion, rear drive shaft.	Used when installing transmission main shaft, needle bearing (transfer case) and rear drive shaft.	Used to install 5th driven gear.	Used to install speedometer shaft oil seal.
 <p style="text-align: right;">B1-200</p>	 <p style="text-align: right;">B1-334</p>	 <p style="text-align: right;">B1-335</p>	 <p style="text-align: right;">B1-336</p>

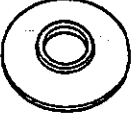
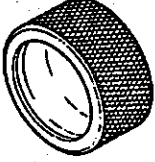
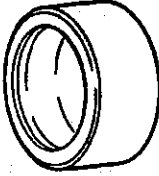

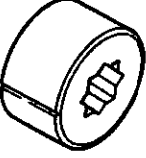

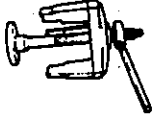


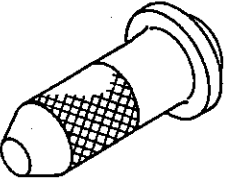
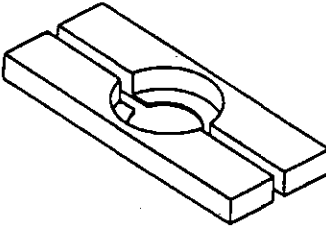

SPECIAL TOOLS

[0200] 1-6

899858600	899864100	899874100	899884100
RETAINER II	REMOVER	INSTALLER	HOLDER
Used when installing transmission main shaft and drive pinion.	Used to remove parts on transmission main shaft and drive pinion.	Used when installing transmission main shaft, drive pinion and transfer drive gear bushing.	Used to tighten lock nut on sleeve.
 <p style="text-align: right;">B1-337</p>	 <p style="text-align: right;">B1-201</p>	 <p style="text-align: right;">B1-339</p>	 <p style="text-align: right;">B1-202</p>
899904100	899988608		
REMOVER	SOCKET WRENCH (27)		
Used to remove and install straight pin.	Used to remove and install transmission main shaft lock nut (FWD) and rear drive shaft (4WD).		
 <p style="text-align: right;">B1-203</p>	 <p style="text-align: right;">B1-204</p>		


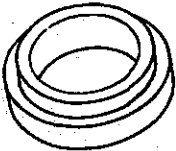
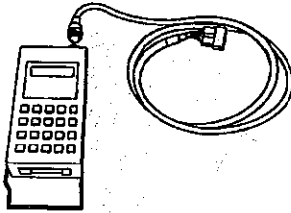
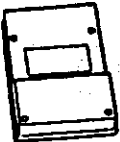
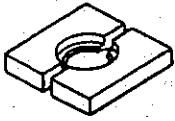
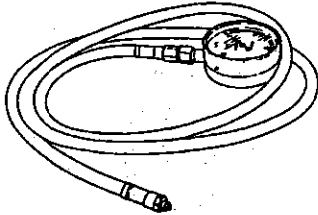
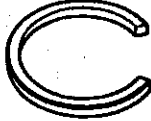
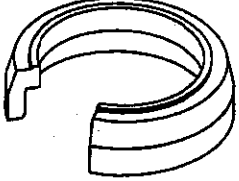
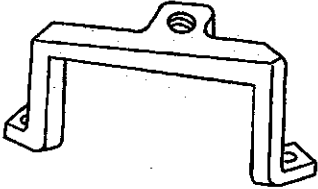
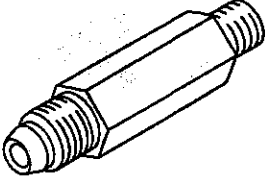
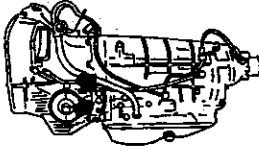
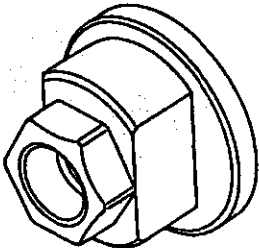
3. Automatic Transmission and Differential Tools

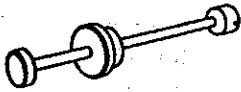
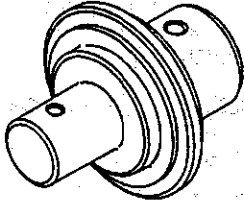
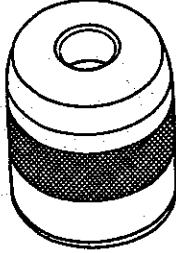
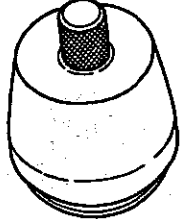

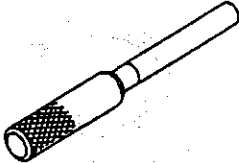
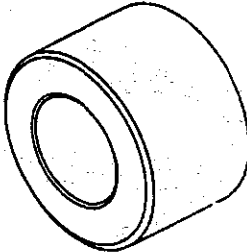
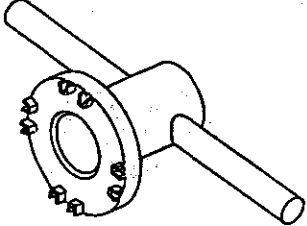
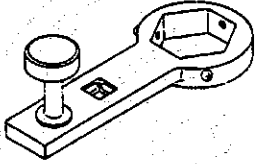

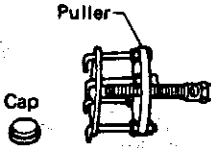

1. 4-SPEED AT

398177700	398437700	398487700	398527700
INSTALLER	DRIFT	DRIFT	PULLEY ASSY
Used to install reverse clutch and high clutch snap rings.	Used to remove and install drive pinion front bearing cup.	Used to remove and install transmission case roller bearing.	Used to remove and install extension case roller bearing.
			
B1-205	B1-223	B1-206	B1-207
398603610	398643600	398673600	398703600
SOCKET	GAUGE	COMPRESSOR	PULLER
Used to remove and install brake band.	Low & reverse brake, total end play, oil pump, drive pinion height.	Used to remove and install reverse clutch, forward clutch and low & reverse brake.	Used to remove axle shaft bearing cup.
			
B1-340	B1-341	B1-342	B1-343
399893600	498057300	498077000	498247001
PLIERS	INSTALLER	REMOVER	MAGNET BASE
Used to remove and install reverse clutch, forward clutch and low & reverse brake.	Used to install extension oil seal.	For removing differential taper roller bearing.	<ul style="list-style-type: none"> • Used when measuring backlash of gears. • Used with DIAL GAUGE (498247100).
			
B1-344	B1-208	B1-210	B1-182

SPECIAL TOOLS

[0301] 1-6

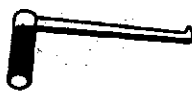
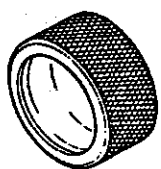
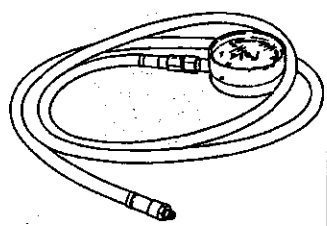
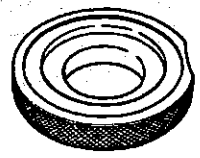
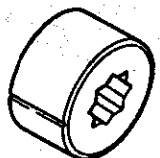


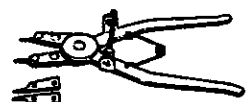
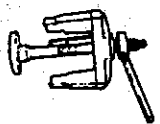
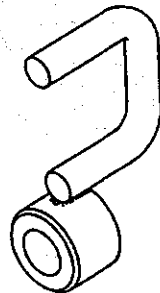
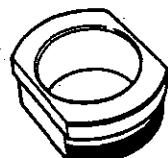

498247100	498267400	498307500	498348800★
DIAL GAUGE	TABLE	SELECT MONITOR KIT	CARTRIDGE
<ul style="list-style-type: none"> • Used when measuring backlash of gears • Used with MAGNET BASE (498247001). 	Used to remove transfer piston seal.	Troubleshooting for electrical systems.	Used with SELECT MONITOR KIT (498307500).
			
B1-183	B1-147	B1-316	B1-317
498517000	498575400	498627000	498627100
REPLACER	OIL PRESSURE GAUGE ASSY	SEAT	SEAT
Used to remove and install drive pinion front bearing core.	Used when measuring oil pressure.	Used to install center support snap ring.	Used to hold overrunning clutch piston retainer (return spring) when installing snap ring.
			
B1-184	B1-211	B1-345	B1-346
498677010	498897200		498937100
COMPRESSOR	ADAPTER CP		HOLDER
Used to remove band piston servo.	Used on oil pump housing when measuring reverse clutch pressure and line pressure.	Used when measuring oil pressure at the following two points.	Used to loosen and tighten M30 lock nut for drive pinion.
			
B1-212	B1-213	C1-112	B1-347

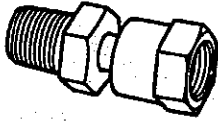
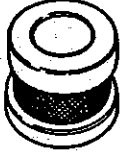

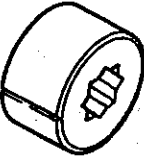
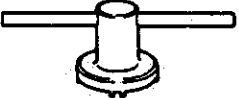

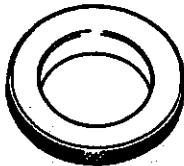

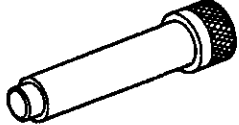
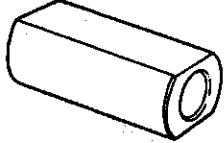
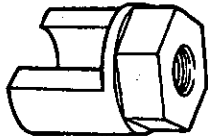
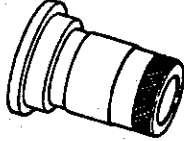
<p>499095500</p>	<p>499247300</p>	<p>499247400</p>	<p>499257300</p>
<p>REMOVER ASSY</p>	<p>INSTALLER</p>	<p>INSTALLER</p>	<p>GUIDE</p>
<ul style="list-style-type: none"> Used to extract axle drive shaft from differential ASSY. Used with INSTALLER (499247300) 	<ul style="list-style-type: none"> Used to install drive pinion oil seal. Used with REMOVER ASSY (499095500). 	<ul style="list-style-type: none"> Used to install transfer outer snap ring. Used with GUIDE (499257300). 	<ul style="list-style-type: none"> Used to install transfer outer snap ring. Used with INSTALLER (499247400).
 <p>B1-348</p>	 <p>B1-349</p>	 <p>B1-148</p>	 <p>B1-149</p>
<p>499257400</p>	<p>499267300</p>	<p>499577000</p>	<p>499787000</p>
<p>GUIDE</p>	<p>STOPPER PIN</p>	<p>GAUGE</p>	<p>WRENCH ASSY</p>
<p>Used to install transfer piston seal.</p>	<p>Used to align range selector lever/ inhibitor switch.</p>	<p>Used when measuring the transmission case mating surface to the reduction gear end surface.</p>	<p>Used to remove and install differential side retainer.</p>
 <p>B1-150</p>	 <p>B1-350</p>	 <p>B1-351</p>	 <p>B1-215</p>
<p>499787100</p>	<p>499827000</p>	<p>899524100</p>	<p>899580100</p>
<p>WRENCH ASSY</p>	<p>PRESS</p>	<p>PULLER SET</p>	<p>INSTALLER</p>
<p>Used to loosen and tighten M30 lock nut for drive pinion.</p>	<p>Used to install speedometer shaft oil seal.</p>	<p>Used to remove roller bearing (Differential).</p>	<p>Used to install drive pinion.</p>
 <p>B1-352</p>	 <p>B1-193</p>	 <p>B1-353</p>	 <p>B1-235</p>

SPECIAL TOOLS

[0302] 1-6

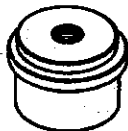




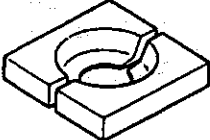
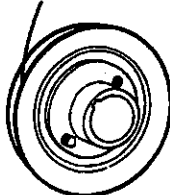

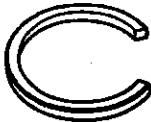
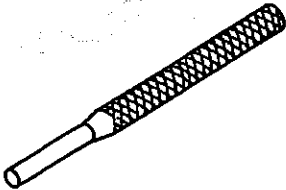

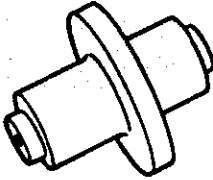
2. 3-SPEED AT


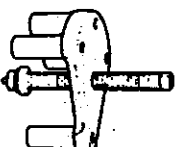
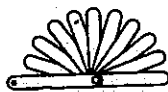
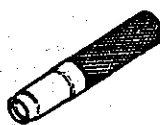
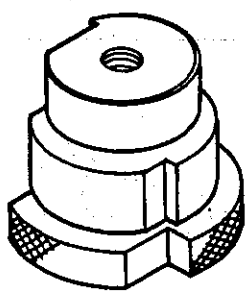
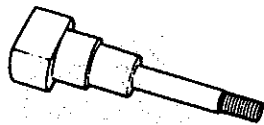
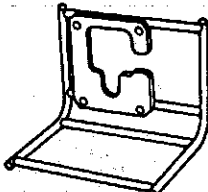
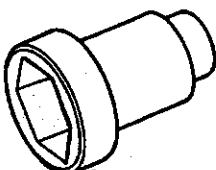



398308700	398437700	398573600	398583600
PULLER	DRIFT	OIL PRESSURE GAUGE ASSY	GAUGE
Used to remove transmission case oil seal.	Used to remove drive pinion front bearing cup.	Used when measuring line pressure and governor pressure.	Used to install reduction drive gear assembly.
			
B1-354	B1-223	B1-211	B1-355
398603610	398643600	398653600	398663600
SOCKET	GAUGE	SHAFT	PLIERS
Used to remove band brake.	Low & reverse brake, total end play, oil pump, drive pinion height.	Used to install drive pinion and reduction drive gear.	Used to remove and install governor valve.
			
B1-340	B1-341	B1-357	B1-358
398673600	398781600	398833600	398863600
COMPRESSOR	STOPPER	GUIDE	INSTALLER 2
Used to remove and install reverse clutch, forward clutch and low & reverse brake.	Used to remove reduction drive gear.	Used to install needle bearing.	Used to install needle bearing on oil pump carrier.
			
B1-342	B1-185	B1-359	B1-360

398893600	399513600	399543600	399703600
ADAPTER	INSTALLER	INSTALLER	PULLER
Used when measuring line pressure and governor pressure.	Used to install drive pinion rear bearing cup.	Used to install needle bearing and bushing on oil pump housing.	Used to remove axle shaft bearing cup.
			
B1-361	B1-177	B1-362	B1-340
399780111	399793600	399790110	399893600
WRENCH	INSTALLER	INSTALLER	PLIERS
Used to remove axle shaft oil seal holder.	Used to install final reduction case.	Used to install roller bearing on axle shaft oil seal.	Used to remove and install reverse clutch, forward clutch and low & reverse brake.
			
B1-363	B1-364	B1-365	B1-344
399903600	399913601	399913603	399913604
REMOVER 2	MASTER	HOLDER	SPACER
Used to remove needle bearing and bushing on oil pump carrier.	Drive pinion.	Used to remove and install drive pinion.	Drive pinion.
			
B1-366	B1-367	B1-368	B1-369

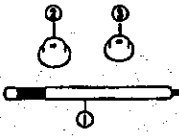
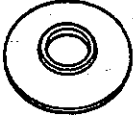
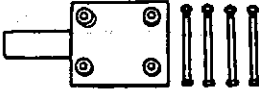


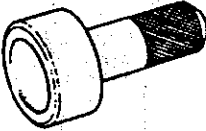
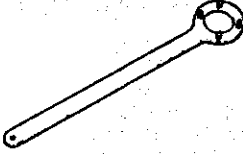
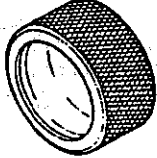
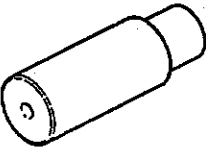

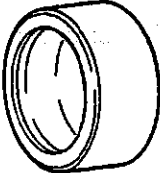
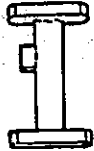
SPECIAL TOOLS

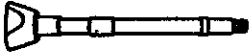

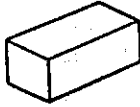
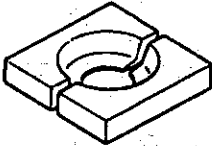
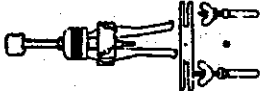
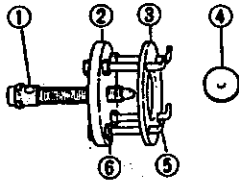



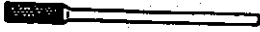

[0302] 1-6

498107000	498147000	498247001	498247100
REPLACER	DEPTH GAUGE	MAGNET BASE	DIAL GAUGE
Used to remove and install impeller bushing on converter housing.	Low & reverse brake.	<ul style="list-style-type: none"> • Used when measuring backlash of gears. • Used with DIAL GAUGE (498247100). 	<ul style="list-style-type: none"> • Used when measuring backlash of gears. • Used with MAGNET BASE (498247001).
			
B1-370	B1-181	B1-182	B1-183
498477000	498517000	498567000	498597000
HANDLE	REPLACER	PULLEY	SOCKET WRENCH (7)
Bearing cup, needle bearing, drive pinion front bearing, retainer and impeller bushing.	Used to remove and install drive pinion front bearing core.	Used when checking preload.	
			
B1-371	B1-231	B1-372	B1-373
498627000	498797000	498897000	499247000
SEAT	REMOVER	ADAPTER	INSTALLER
Used to install center support snap ring.	Used to remove pin for bushing of oil pump shaft.	Used when measuring line pressure.	Drive pinion oil seal.
			
B1-345	B1-374	B1-375	B1-376

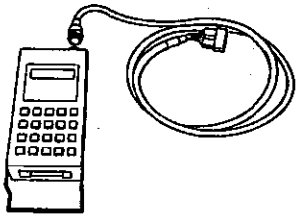
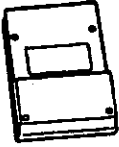
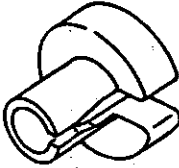
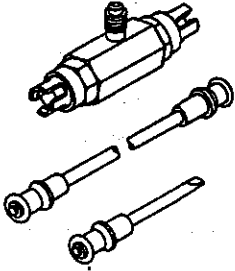
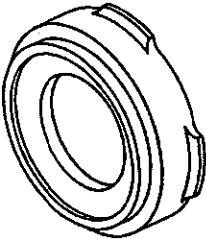
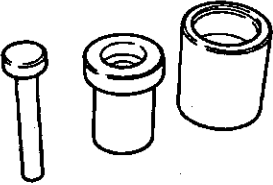
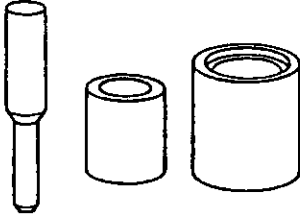
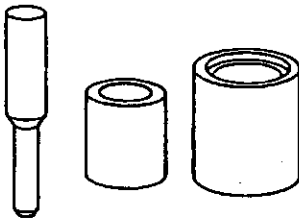
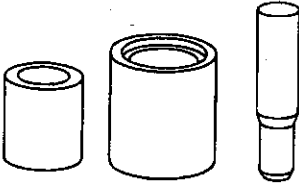
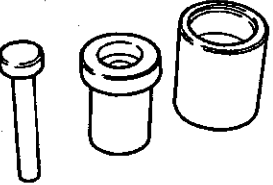
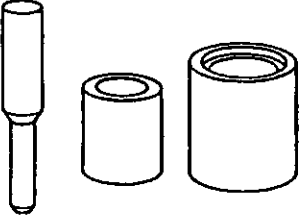
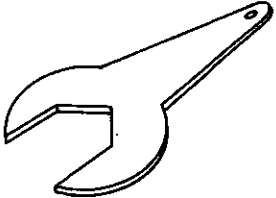
499257100	499527000	499667000	499827000
OIL SEAL GUIDE	PULLER SET	THICKNESS GAUGE	PRESS
Drive pinion oil seal.	Used to remove and install final reduction case.	Forward clutch, reverse clutch low & reverse brake and oil pump etc.	Used to install speedometer shaft oil seal.
			
B1-377	B1-378	B1-379	B1-193
499867000	499917400	499937000	499987100
REMOVER	MASTER 2	DIFFERENTIAL STAND	SOCKET WRENCH (35)
Used to remove needle bearing at reduction drive gear.	Drive pinion.	Final reduction section.	Used to remove and install drive pinion.
			
B1-380	B1-381	B1-382	B1-383
899580100	899874100	899924100	
INSTALLER	INSTALLER	HANDLE	
Used to install drive pinion.	Used to install companion flange.	Used to remove and install reduction drive gear.	
			
B1-235	B1-384	B1-385	


4. Rear Wheel Drive System (4WD Models) Tools

397471600	398177700	398217700	398227700
HANDLE & DRIFT KIT	INSTALLER	ATTACHMENT SET	WEIGHT
Front and rear bearing cup.	Rear bearing cone.	Differential case.	Side bearing.
 <p>1 HANDLE (398477701) 2 DRIFT (398477702) 3 DRIFT 2 (398477703)</p> <p>B1-216</p>	 <p>B1-217</p>	 <p>B1-218</p>	 <p>B1-219</p>
398237700	398417700	398427700	398437700
GAUGE	DRIFT	FLANGE WRENCH	DRIFT
Side bearing.	Oil seal.	Companion flange.	Oil seal.
 <p>B1-220</p>	 <p>B1-221</p>	 <p>B1-222</p>	 <p>B1-223</p>
398457700	398467700	398487700	398507701
ATTACHMENT	DRIFT	DRIFT	GAUGE
Side bearing retainer.	Drive pinion, Pilot bearing, Front bearing cone.	Side bearing cone.	Pinion height adjustment.
 <p>B1-224</p>	 <p>B1-225</p>	 <p>B1-226</p>	 <p>B1-227</p>

398507702	398507703	398507704	398517700
DUMMY SHAFT	DUMMY COLLAR	BLOCK	REPLACER
Pinion height and Preload adjustment.	Pinion height and Preload adjustment.	Pinion height and Preload adjustment.	Rear bearing cone.
 <p style="text-align: right;">B1-228</p>	 <p style="text-align: right;">B1-229</p>	 <p style="text-align: right;">B1-230</p>	 <p style="text-align: right;">B1-231</p>
398527700	399527700	399780104	899580100
PULLEY ASSY	PULLER SET	WEIGHT	INSTALLER
Oil seal, Side bearing cup.	Side bearing cone.	Front bearing cone, Pilot bearing, Companion flange.	Front bearing cone, Pilot bearing.
 <p style="text-align: right;">B1-232</p>	 <p>1 BOLT (899521412) 2 PULLER (399527702) 3 HOLDER (399527703) 4 ADAPTER (398497701) 5 BOLT (899520107) 6 NUT (021008000)</p> <p style="text-align: right;">B1-233</p>	 <p style="text-align: right;">B1-234</p>	 <p style="text-align: right;">B1-235</p>
899874100	899904100	925560000	
INSTALLER	STRAIGHT PIN REMOVER	WRENCH	
Companion flange.	Differential pinion shaft lock pin.	Differential spindle set bolt.	
 <p style="text-align: right;">B1-236</p>	 <p style="text-align: right;">B1-237</p>	 <p style="text-align: right;">B1-238</p>	

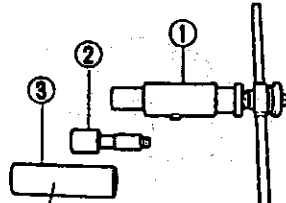
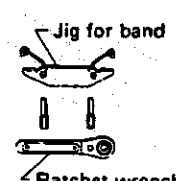
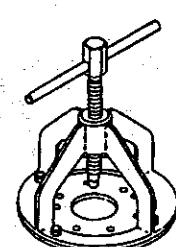

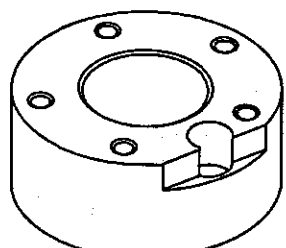
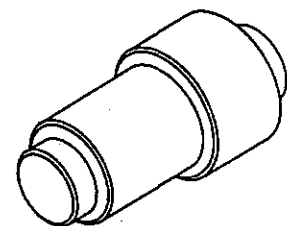
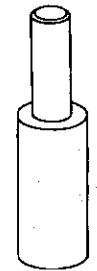
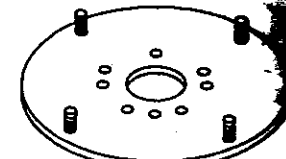
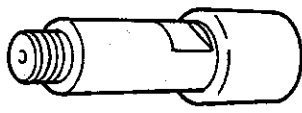
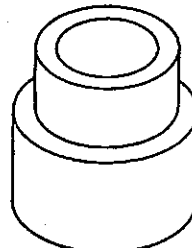
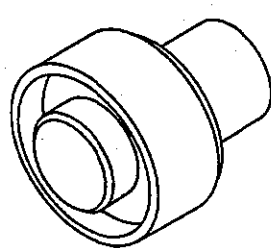
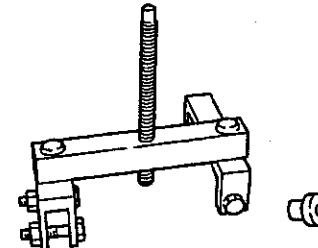
5. Suspension Tools

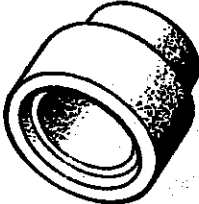
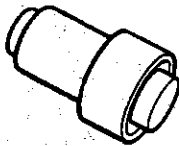
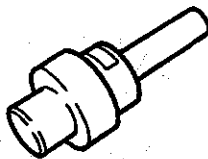
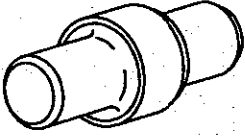
498307500	498347700	926520000	926940000
SELECT MONITOR KIT	CARTRIDGE	AIR PIPE REMOVER	3-WAY JOINT ASSY
Troubleshooting for electrical system.	Used with SELECT MONITOR KIT (498307500).	Used to disassemble air pipe from joint. For Air Suspension	Used as an adapter for gauge manifold of air conditioning system to measure pressure. For Air Suspension
			
B1-316	B1-317	B1-240	B1-388
927380000	927680000	927690000	927700000
ADAPTER	INSTALLER & REMOVER	INSTALLER & REMOVER	INSTALLER & REMOVER
Used as an adapter for Camber & Caster Gauge when measuring camber and caster.	Used to replace transverse link bushing.	Used to replace lateral link bushing (12 dia.).	Used to replace lateral link bushing (14 dia.).
			
B1-241	B1-151	B1-389	B1-389
927710000	927720000	927730000	927750000
INSTALLER & REMOVER	INSTALLER & REMOVER	INSTALLER & REMOVER	SPANNER
Used to replace lateral link bushing (23 dia.).	Used to replace trailing link bushing.	Used to replace rear housing bushing.	Used to disassemble and assemble front air suspension ASSY.
			
B1-390	B1-151	B1-389	B1-391

927760000
STRUT MOUNT SOCKET
Used to disassemble and assemble strut mount.
Except Air Suspension

B1-152

SPECIAL TOOLS

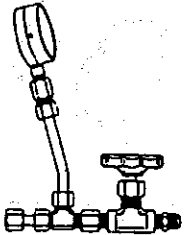
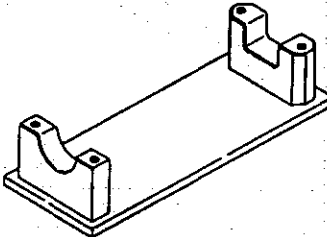
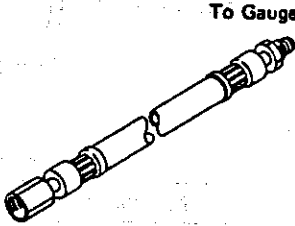
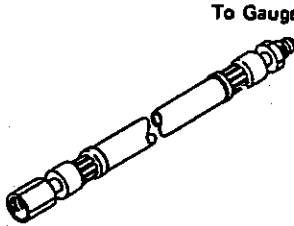
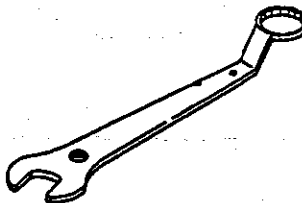
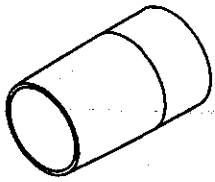
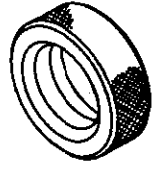
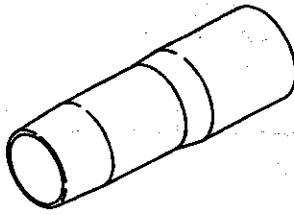
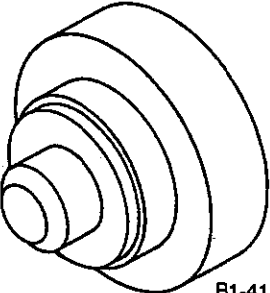
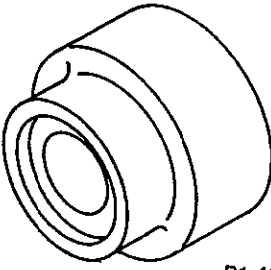
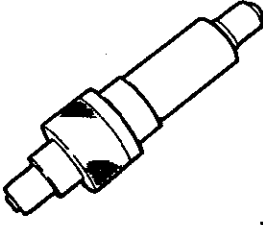

6. Wheels and Axles Tools

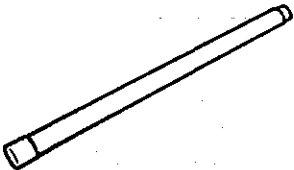
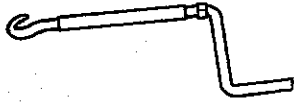
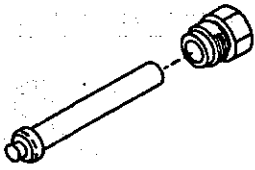
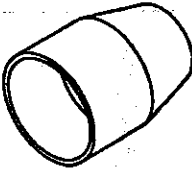
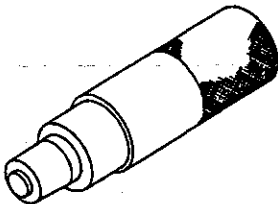
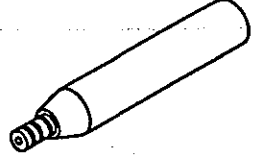
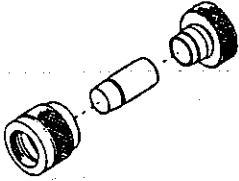
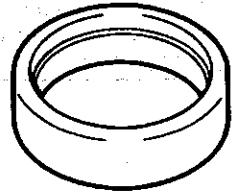
922431000	92509100	926470000	
AXLE SHAFT INSTALLER	BAND TIGHTENING TOOL	AXLE SHAFT PULLER	HUB REMOVER
<ul style="list-style-type: none"> Used to install axle shaft into housing. Used with ADAPTER (927390000). 	For tightening boot band.	Used to remove front axle shaft.	Used to remove rear hub CP.
 <p style="text-align: center;">EXTENSION AXLE SHAFT INSTALLER</p> <p style="text-align: right;">B1-242</p>	 <p style="text-align: center;">B1-243</p>	 <p style="text-align: right;">B1-245</p>	
927080000	927100000	927120000	927140000
HUB STAND	BEARING PULLER	HUB INSTALLER	AXLE SHAFT PULLER FWD
Used to disassemble and assemble hub bolt in rear hub CP. FWD	<ul style="list-style-type: none"> Used to disassemble and assemble front housing bearing. Used with HOUSING STAND (927400000). 	Used to install hub.	Same as plate 2 included AXLE SHAFT PULLER (927070000).
 <p style="text-align: right;">B1-246</p>	 <p style="text-align: right;">B1-247</p>	 <p style="text-align: right;">B1-392</p>	 <p style="text-align: right;">B1-248</p>
927390000	927400000	927410000	927420000
ADAPTER	HOUSING STAND	OIL SEAL INSTALLER	HUB REMOVER
Used as an adapter for AXLE SHAFT INSTALLER (922431000).	<ul style="list-style-type: none"> Used to disassemble and assemble front housing bearing. Used with BEARING PULLER (927100000). 	Used to install oil seal into front housing.	Used to remove rear hub CP.
 <p style="text-align: right;">B1-153</p>	 <p style="text-align: right;">B1-249</p>	 <p style="text-align: right;">B1-250</p>	 <p style="text-align: right;">B1-154</p>

927430000	927440000	927450000	927480000
HOUSING STAND	BEARING REMOVER	HUB INSTALLER	OIL SEAL INSTALLER
<ul style="list-style-type: none"> • Used to disassemble and assemble rear housing bearing. • Used with BEARING PULLER (927440000). 	<ul style="list-style-type: none"> • Used to disassemble and assemble rear housing bearing. • Used with HOUSING STAND (927430000). 	<ul style="list-style-type: none"> • Used to press rear hub CP into housing ASSY. • Used with HOUSING STAND (927430000). 	<ul style="list-style-type: none"> • Used to install outer bearing and sub bearing into housing. • Used with HOUSING STAND (927430000).
 <p style="text-align: right;">B1-155</p>	 <p style="text-align: right;">B1-156</p>	 <p style="text-align: right;">B1-157</p>	 <p style="text-align: right;">B1-407</p>

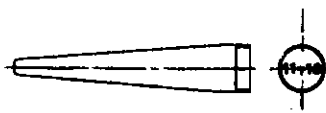
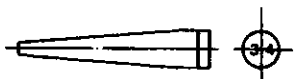
203

7. Steering System Tools

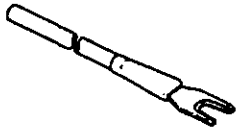
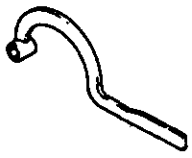
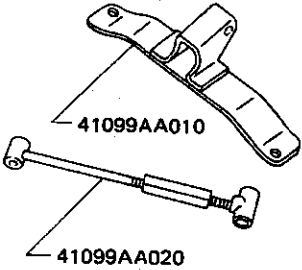
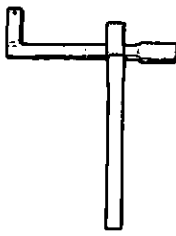
<p>925711000</p>	<p>926200000</p>	<p>926210000</p>	<p>926220000</p>
<p>PRESSURE GAUGE For measuring oil pump pressure.</p>	<p>STAND Used when inspecting characteristic of gearbox ASSY and disassembling it. Vise this tool and secure gearbox ASSY using gearbox clamps.</p>	<p>ADAPTER A Used with PRESSURE GAUGE (925711000).</p>	<p>ADAPTER B Used with PRESSURE GAUGE (925711000).</p>
 <p>B1-251</p>	 <p>B1-252</p>	 <p>To Gauge B1-254</p>	 <p>To Gauge B1-263</p>
<p>926230000</p>	<p>926270000</p>	<p>926280000</p>	<p>926450000</p>
<p>SPANNER • For the lock nut when adjusting backlash of gearbox. • Measurement of rotating resistance of gearbox ASSY.</p>	<p>COVER Used to install oil seal</p>	<p>FORMER Seal ring</p>	<p>COVER Used to install oil seal</p>
 <p>B1-255</p>	 <p>B1-408</p>	 <p>B1-409</p>	 <p>B1-410</p>
<p>926970000</p>	<p>926980000</p>	<p>927540000</p>	<p>927600000</p>
<p>INSTALLER Used to install oil seal</p>	<p>GUIDE • Used to install shaft to bearing • Used to install shaft ASSY into body</p>	<p>REMOVER Used to remove bearing, seal, etc. for valve ASSY</p>	<p>FORMER Seal ring</p>
 <p>B1-411</p>	 <p>B1-412</p>		

927580000	927590000	926420000	926250000
REMOVER	WRENCH	PLUG	GUIDE
Used to remove back-up ring and oil seal.	Used to remove wire from boot.	Used to close the oil circuit after removing pipe ASSY from the housing.	Used to install holder ASSY into rack housing.
 <p style="text-align: right;">B1-415</p>	 <p style="text-align: right;">B1-416</p>	 <p style="text-align: right;">B1-165</p>	 <p style="text-align: right;">L1-190</p>
926300000	926310000	927490000	927560000
INSTALLER	GUIDE	INSTALLER A, B, C	SPACER
Used to install dust seal, Y-packing, back-up washer into valve housing.	Used to install valve ASSY into valve housing ASSY.	Used to install oil seal into rack ASSY.	Used to install ball-bearing into valve housing ASSY.
 <p style="text-align: right;">L1-195</p>	 <p style="text-align: right;">L1-196</p>	 <p style="text-align: right;">B1-477</p>	 <p style="text-align: right;">B1-478</p>

8. Brakes Tools

925460000	926460000
WHEEL CYLINDER 11/16' ADAPTER	WHEEL CYLINDER 3/4' ADAPTER
Used to install cup onto wheel cylinder piston (Size 11/16 in).	Used to install cup onto wheel cylinder piston (Size 3/4 in)
	
B1-403	B1-404

9. Body Tools

925580000	925610000	41099AA000	927780000
PULLER	WRENCH	ENGINE SUPPORT ASSY	REMOVER
Trim clip. All models	Door hinge. All models	For supporting engine.	Used to remove and install trunk torsion bar. 4-Door Sedan only
			
B1-267	B1-268	B1-522	B1-169

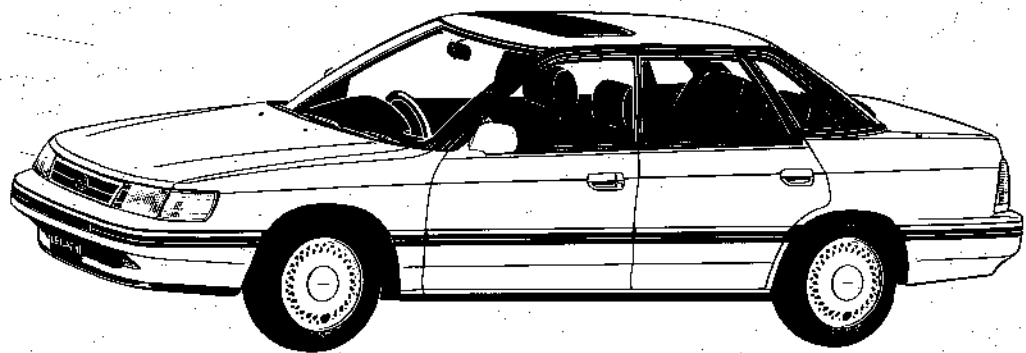




SUBARU® LEGACY

1992 SERVICE MANUAL

SECTION 4



FUJI HEAVY INDUSTRIES LTD.

SUBARU®

1992

SERVICE MANUAL

FOREWORD

This service manual has been prepared to provide SUBARU service personnel with the necessary information and data for the correct maintenance and repair of SUBARU vehicle.

This manual include the procedures for maintenance, disassembling, reassembling, inspection and adjustment of components and troubleshooting for guidance of both the fully qualified and the less-experienced mechanics.

Please peruse and utilize this manual fully to ensure complete repair work for satisfying our customers by keeping their vehicle in optimum condition. When replacement of parts during repair work is needed, be sure to use SUBARU genuine parts.

All information, illustration and specifications contained in this manual are based on the latest product information available at the time of publication approval.

FUJI HEAVY INDUSTRIES LTD.

All right reserved. This book may not be reproduced or copied, in whole or in part, without the written permission of
 FUJI HEAVY INDUSTRIES LTD., TOKYO JAPAN.

SUBARU,  and  are trademarks of
 FUJI HEAVY INDUSTRIES LTD.

© Copyright 1991 FUJI HEAVY INDUSTRIES LTD.

4 MECHANICAL COMPONENTS SECTION

SUSPENSION	4-1
WHEELS AND AXLES	4-2
STEERING SYSTEM	4-3
BRAKES	4-4
PEDAL SYSTEM AND CONTROL CABLES	4-5
HEATER AND VENTILATOR	4-6
*****	4-7

TABLE OF CONTENTS

1 GENERAL SECTION	1-1 Specifications 1-2 ★★★★★★★★★★ 1-3 General Information 1-4 Pre-Delivery Inspection 1-5 Periodic Maintenance Service 1-6 Special Tools
2 ENGINE SECTION	2-1 Emission Control System 2-2 On-Car Services 2-3a Engine (SOHC) 2-3b Engine (DOHC) 2-4 Engine Lubrication System 2-5 Engine Cooling System 2-6 Carburetor 2-7a Fuel Injection System (MPFI) 2-7b Fuel Injection System (SPI) 2-7c Fuel Injection System (MPFI) 2-8 Fuel System 2-9 Exhaust System 2-10 Clutch 2-11 Engine and Transmission
3 TRANSMISSION AND DIFFERENTIAL SECTION	3-1 Manual Transmission and 3-2a Automatic Transmission and 3-2b ★★★★★★★★★★ 3-3 Transmission Control System 3-4 4WD System
4 MECHANICAL COMPONENTS SECTION	4-1 Suspension 4-2 Wheels and Axles 4-3 Steering System 4-4 Brakes 4-5 Pedal System and Control Cables 4-6 Heater and Ventilator 4-7 ★★★★★★★★★★
5 BODY SECTION	5-1 Body and Exterior 5-2 Doors and Windows 5-3 Seats, Seat Belts, and Interior 5-4 Instrument Panel
6 ELECTRICAL SECTION	6-1 Engine Electrical System 6-2 Body Electrical System 6-3 Wiring Diagram and Troubleshooting

SUBARU

1992

**SERVICE
MANUAL**



	Page
M MECHANISM AND FUNCTION	2
1. Front-Suspension	2
2. Rear Suspension	3
3. Air (Pneumatic) Suspension with Height Control ...	4
S SPECIFICATIONS AND SERVICE DATA	13
C COMPONENT PARTS	15
1. Conventional Suspension	15
2. Air (Pneumatic) Suspension	18
W SERVICE PROCEDURE FOR CONVENTIONAL SUSPENSION	20
1. On-car Services	20
2. Front Transverse Link Assembly	27
3. Front Ball Joint	29
4. Front Strut Assembly	31
5. Front Stabilizer	35
6. Front Crossmember	36
7. Rear Trailing Link Assembly	38
8. Lateral Link Assembly	41
9. Rear Strut Assembly	45
10. Rear Crossmember (FWD)	48
11. Rear Crossmember (4WD)	49
*X SERVICE PROCEDURE FOR AIR (PNEUMATIC) SUSPENSION WITH HEIGHT CONTROL	53
1. General Precautions	53
2. Front Air Suspension Strut Assembly	53
3. Rear Air Suspension Strut Assembly	56
4. Compressor & Drier Assembly	57
5. Air Tank Assembly	58
6. Front Suction and Discharge Solenoid Valve	59
7. Rear Suction and Discharge Solenoid Valve	60
T TROUBLESHOOTING	61
1. Conventional Suspension	61
2. Troubleshooting for Air Suspension	62
3. Air Suspension Control Unit I/O Signal	65
4. Diagram of Air Suspension System	68
5. Troubleshooting Chart with Trouble Code	70
6. Troubleshooting with Select Monitor	84
7. General Troubleshooting Table for Air Suspension	88

* In this topic are described the different points of the air (pneumatic) suspension from the explanations described in the above topic. Accordingly, use this topic together with the above topic.

M MECHANISM AND FUNCTION

1. Front Suspension

A: OUTLINE

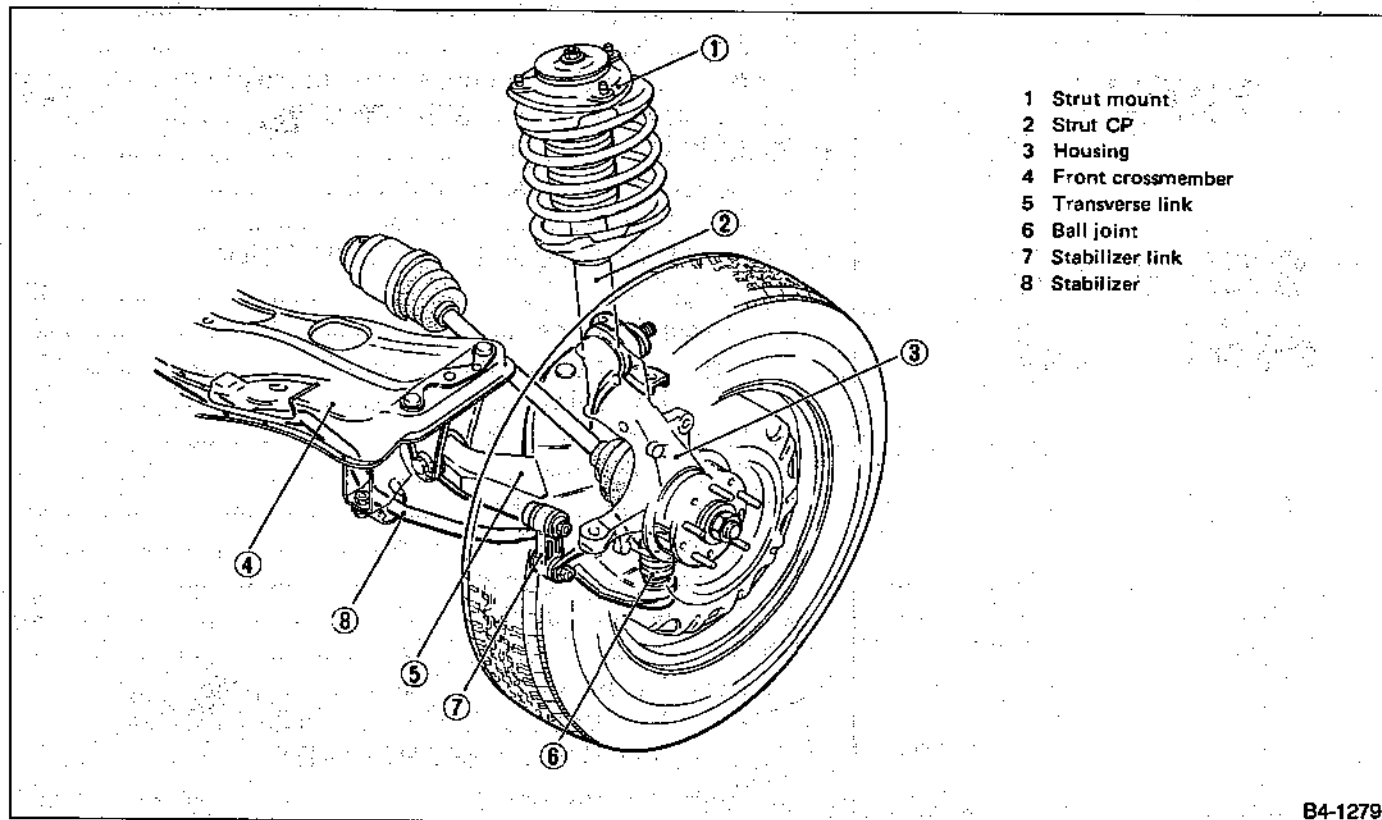


Fig. 1

The front suspension is a strut-type independent suspension, with cylindrical double-acting oil damper and coil spring [or air spring for air (pneumatic) suspension].

The top of the oil damper is mounted on the body through the cushion rubber, which has resulted in elimination of any vibration by combined use of other rubbers to improve passenger comfort. This type also maintains a wide distance between the upper and lower supporting points and makes adjustment of the caster unnecessary.

The transverse link utilizes an "L" arm design to increase steering stability and reduce road noise. The transverse link has a maintenance free ball joint with a nut fitting at the outer end, and the inner end front side fitted to the front crossmember through the cushion rubber. The rear side of the inner end is bolted to the vehicle body through a fluid-filled bushing.

The front crossmember is bolted to the vehicle body.

The stabilizer is attached to the front crossmember through the cushion rubbers and its ends are connected to the stabilizer links through the rubber bushings.

The lower end of the stabilizer link is connected to the transverse link through rubber bushings.

A camber angle adjustment mechanism, which uses eccentric bolts, is provided at the joint of the damper strut and housing.

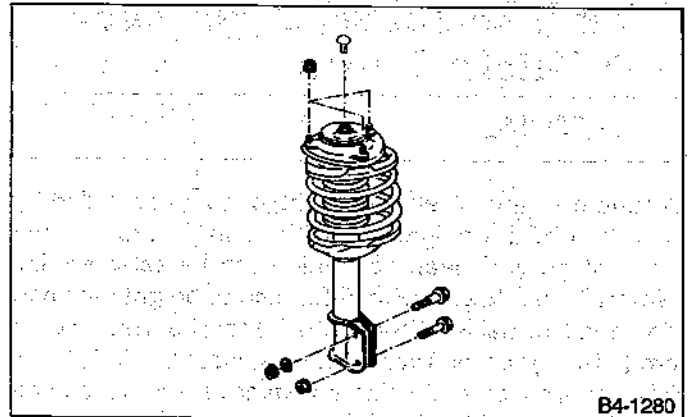
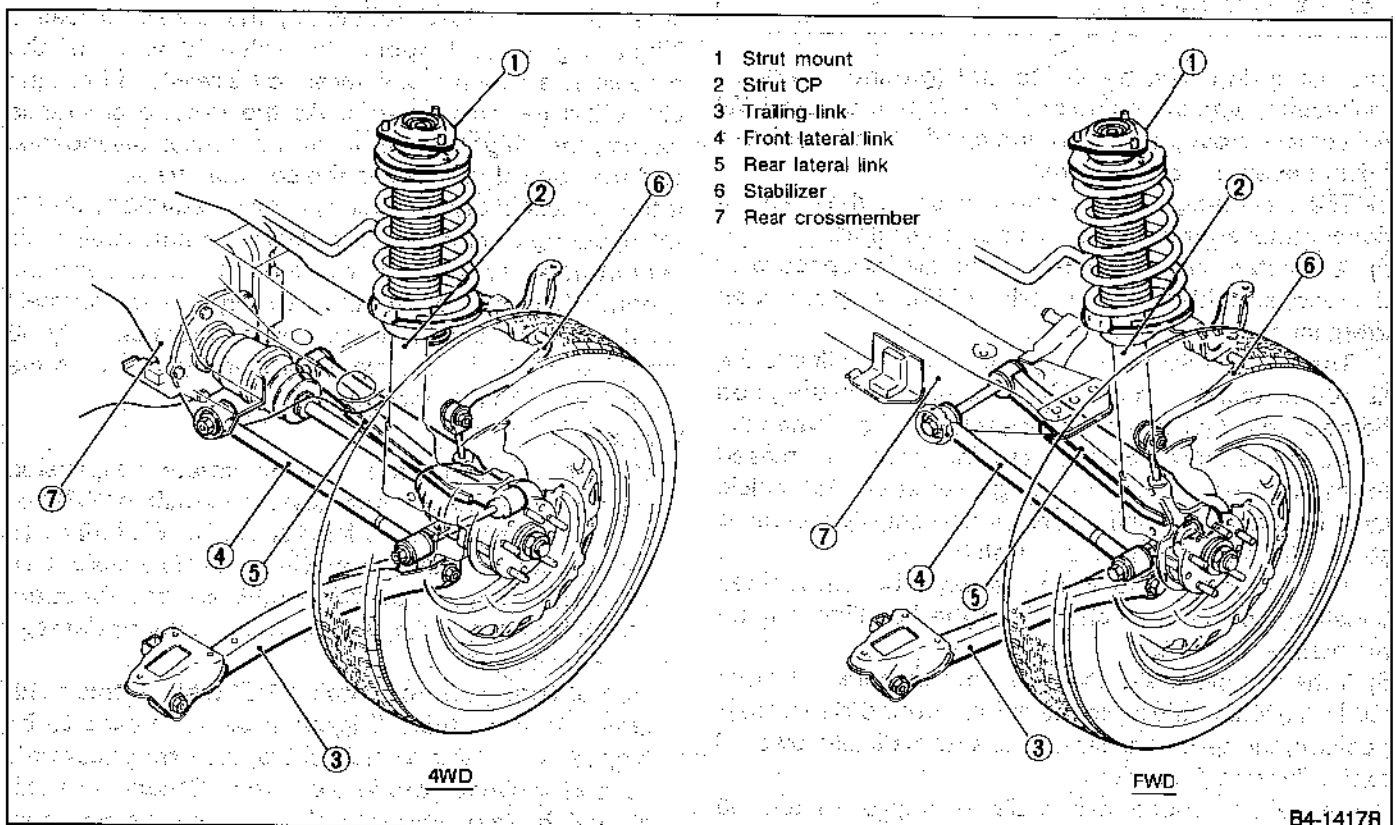


Fig. 2

B4-1280

2. Rear Suspension

A: OUTLINE



- 1 Strut mount
- 2 Strut CP
- 3 Trailing-link
- 4 Front lateral link
- 5 Rear lateral link
- 6 Stabilizer
- 7 Rear crossmember

B4-1417R

Fig. 3

The rear suspension is an independent, dual link strut type. It consists of two parallel lateral links, a trailing link which moves back and forth, and shock absorber ASSY's. The shock absorber assembly is joined with a cylindrical double-acting oil damper and coil spring [or air spring for the air suspension].

The respective component parts of this suspension are optimally designed to act in response to vertical, lateral and transverse loads transmitted from the tires. Thus, riding comfort and steering stability are substantially enhanced.

- Transverse loads act on the trailing link.
- Vertical loads act on the coil spring, rear strut and rear rubber mount (which is located on the strut).
- Lateral loads act on the two lateral links.

The crossmember is installed on the body frame via bushings.

The stabilizer that extends to the rear of the crossmember, is installed on the body frame using a bracket and to the rear lateral link on the wheel side.

S SPECIFICATIONS AND SERVICE DATA

A: SPECIFICATIONS

1. CONVENTIONAL SUSPENSION

1. Stabilizer

			Bar dia. mm (in)	
			Front	Rear
4-DOOR SEDAN	FWD	1600 cc	17 (0.67)	—
		1800 cc	17 (0.67)	—
		2000 cc	17 (0.67)	—
		2200 cc	18 (0.71)	14 (0.55)
	4WD	1800 cc	17 (0.67)	—
		2000 cc	17 (0.67)	—
		TURBO	18 (0.71)	18 (0.71)
		2200 cc	18 (0.71)	14 (0.55)
STATION WAGON	FWD	1600 cc	18 (0.71)	—
		1800 cc	18 (0.71)	—
		2000 cc	18 (0.71)	—
	4WD	2200 cc	19 (0.75)	14 (0.55)
		1800 cc	18 (0.71)	—
		2000 cc	18 (0.71)	—
TOURING WAGON	FWD	1600 cc	18 (0.71)	—
		2200 cc	19 (0.75)	14 (0.55)
	4WD	1800 cc	19 (0.75)	—
		2000 cc	19 (0.75)	—
		TURBO	18 (0.71)	16 (0.63)
		2200 cc	19 (0.75)	14 (0.55)

2. AIR (PNEUMATIC) SUSPENSION

2-1 Stabilizer

Bar dia. mm (in)	Front	19 (0.75)
	Rear	18 (0.71)

2-2 Air suspension

	Max. length mm (in)	Min. length mm (in)	Stroke mm (in)	Damping force [at a piston speed of 0.3 m (1 ft) / sec.] N (kg, lb)	
				Expansion (normal / high)	Compression (normal / high)
Front	508 (20.00)	382 (15.04)	126 (4.96)	628 / 1,079 (64 / 110, 141 / 243)	275 / 392 (28 / 40, 62 / 88)
Rear	600 (23.62)	439 (17.28)	162 (6.38)	490 / 883 (50 / 90, 110 / 198)	294 / 392 (30 / 40, 66 / 88)

B: WHEEL ALIGNMENT

		Sedan			Wagon			Air sus- pension vehicle
		FWD	4WD	TURBO	FWD	4WD	TURBO	4WD
Front	Camber (common difference: ± 0°30')	— 0°15'	0°	— 0°15'	— 0°15'	0°	— 0°15'	0°
	Caster (common difference: ± 1°)	3°05'	3°	2°50'	2°50'	2°45'	2°50'	3°
	Toe mm (in)	0 ± 3 (0 ± 0.12) Toe-in angle: — 0°09' [when toe-in is — 3 (— 0.12)] Toe-out angle: 0°09' [when toe-out is 3 (0.12)]						
	Kingpin angle	14°20'	14°05'	14°20'	14°20'	14°05'	14°20'	14°05'
	Wheel arch height [common difference: ± 10 mm (± 0.39 in)] mm (in)	378 (14.88) *388 (15.28)	388 (15.28)	378 (14.88)	378 (14.88)	388 (15.28)	378 (14.88)	388 (15.28)
Rear	Camber (common difference: ± 0°45')	— 1°	— 1°	— 1°	— 0°50'	— 0°50'	— 1°	— 1°
	Toe mm (in)	0 ± 3 (0 ± 0.12) Toe-in angle: — 0°09' [when toe-in is — 3 (— 0.12)] Toe-out angle: 0°09' [when toe-out is 3 (0.12)]						
	Wheel arch height [common difference: ± 10 mm (± 0.39 in)] mm (in)	359 (14.13) *388 (15.28)	369 (14.53)	364 (14.33)	369 (14.53)	379 (14.92)	364 (14.33)	369 (14.53)

*: 2200 cc model

If the inspection data is out of "SERVICE LIMIT", read-just.

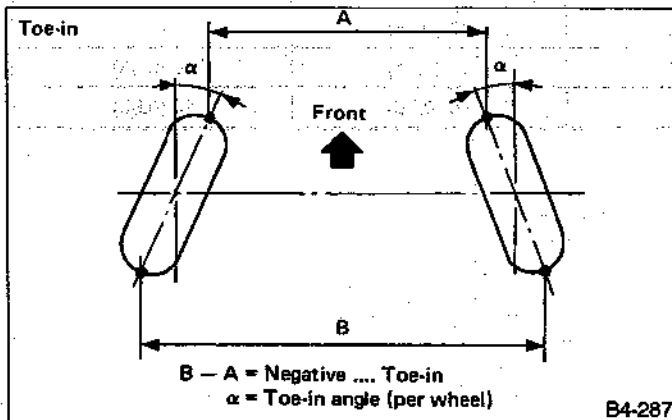


Fig. 19

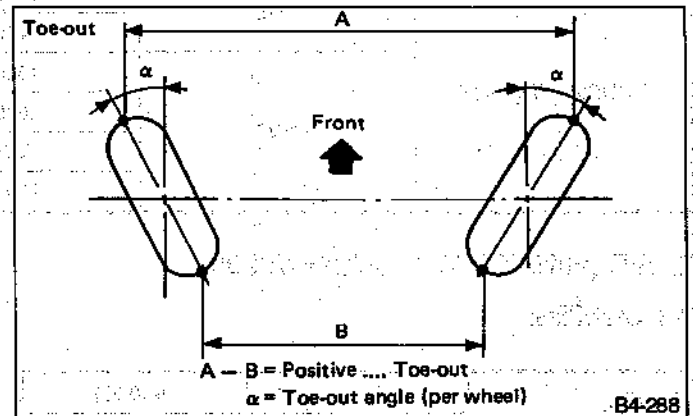


Fig. 20

C: SERVICE DATA

1. CONVENTIONAL SUSPENSION

Strut	Piston rod deflection Limit	0.8 mm (0.031 in)/ 20 N (2 kg, 4 lb)
-------	--------------------------------	---

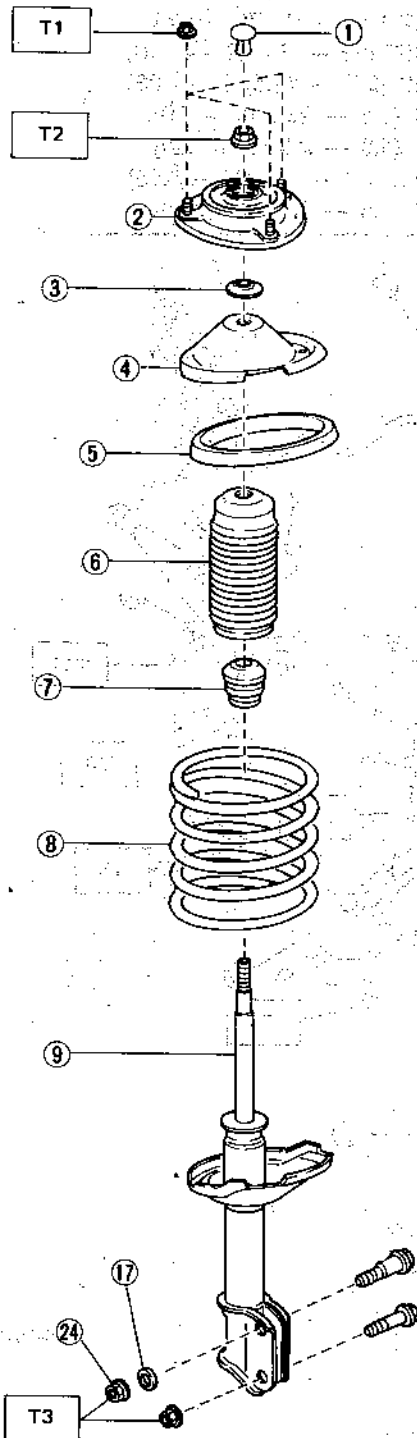
2. AIR (PNEUMATIC) SUSPENSION

Recommended grease Recommended O-ring	NOK SEALUB S-4 NOK material; P8A980
--	--

C COMPONENT PARTS

1. Conventional Suspension

1. FRONT



Tightening torque: N·m (kg·m, ft·lb)

T1: 14 - 25 (1.4 - 2.6, 10 - 19)

T2: 49 - 59 (5 - 6, 36 - 43)

T3: 132 - 172 (13.5 - 17.5, 98 - 127)

T4: 21 - 28 (2.1 - 2.9, 15 - 21)

T5: 23 - 42 (2.3 - 4.3, 17 - 31)

T6: 38 - 50 (3.9 - 5.1, 28 - 37)

T7: 25 - 34 (2.5 - 3.5, 18 - 25)

T8: 83 - 113 (8.5 - 11.5, 61 - 83)

T9: 196 - 294 (20 - 30, 145 - 217)

T10: 39 (4.0, 29)

- 1 Dust seal
- 2 Strut mount
- 3 Spacer
- 4 Upper spring seat
- 5 Rubber seat
- 6 Dust cover
- 7 Helper
- 8 Coil spring
- 9 Damper strut
- 10 Crossmember CP
- 11 Cotter pin
- 12 Front stabilizer
- 13 Jack-up plate
- 14 Bolt CP
- 15 Bushing
- 16 Clamp
- 17 Washer
- 18 Stabilizer link
- 19 Castle nut
- 20 Ball joint
- 21 Front bushing
- 22 Rear bushing
- 23 Washer
- 24 Self lock nut
- 25 Transverse link

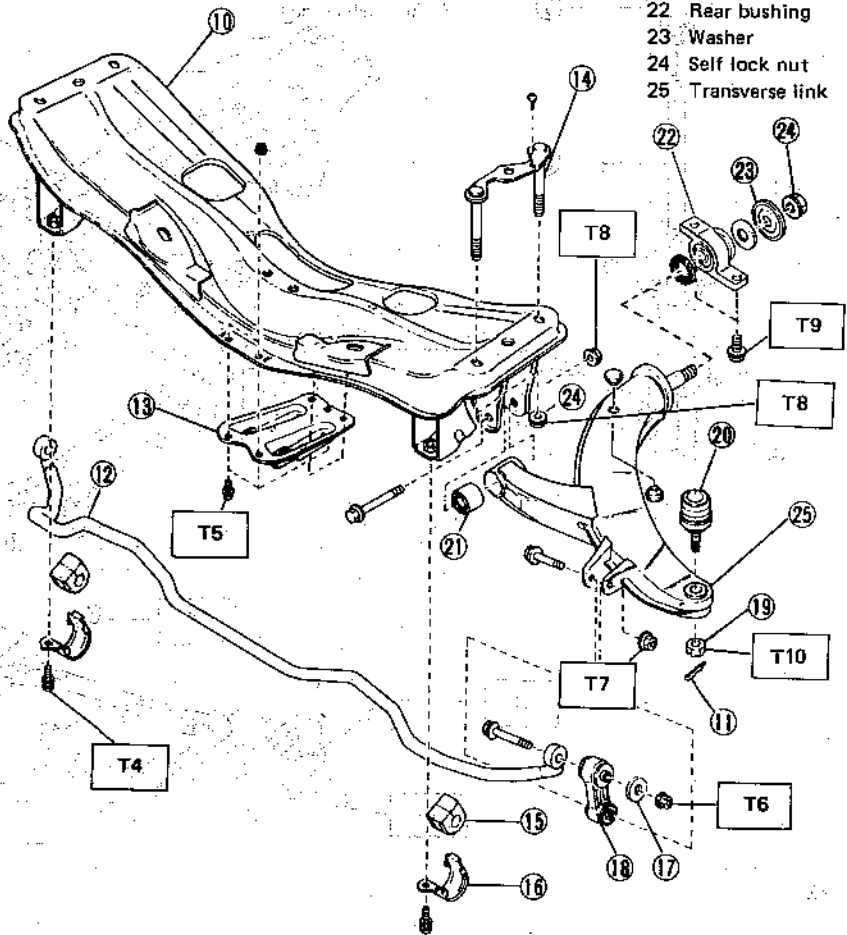
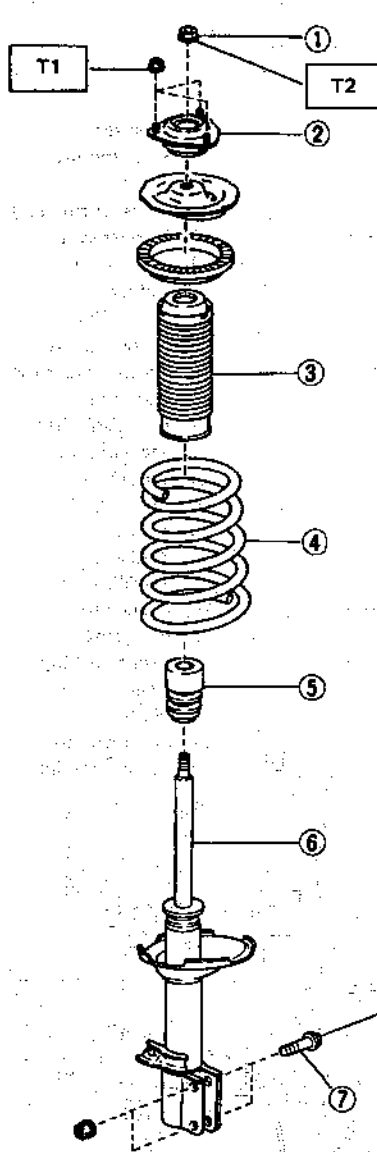


Fig. 21

B4-1447

2. REAR (4WD)



- 1 Self-lock nut
- 2 Strut mount
- 3 Dust cover
- 4 Coil spring
- 5 Rear helper
- 6 Strut CP
- 7 Flange bolt
- 8 Rear crossmember
- 9 Floating bushing
- 10 Front lateral link
- 11 Bushing (A)
- 12 Bushing (B)
- 13 Bushing (C)
- 14 Trailing link
- 15 Bushing
- 16 Rear stabilizer
- 17 Stabilizer bushing
- 18 Stabilizer bracket
- 19 Clamp
- 20 Stabilizer link
- 21 Washer
- 22 Bushing
- 23 Bracket CP
- 24 Stopper
- 25 Cap
- 26 Washer
- 27 Rear lateral link

Tightening torque: N·m (kg·m, ft·lb)

T1:	14 - 25 (1.4 - 2.6, 10 - 19)
T2:	49 - 69 (5 - 7, 36 - 51)
T3:	186 - 235 (19 - 24, 137 - 174)
T4:	78 - 118 (8 - 12, 58 - 87)
T5:	98 - 127 (10 - 13, 72 - 94)
T6:	118 - 157 (12 - 16, 87 - 116)
T7:	83 - 113 (8.5 - 11.5, 61 - 83)
T8:	14 - 25 (1.4 - 2.6, 10 - 19)
T9:	18 - 27 (1.8 - 2.8, 13 - 20)
T10:	108 - 147 (11 - 15, 80 - 108)
T11:	18 - 31 (1.8 - 3.2, 13 - 23)

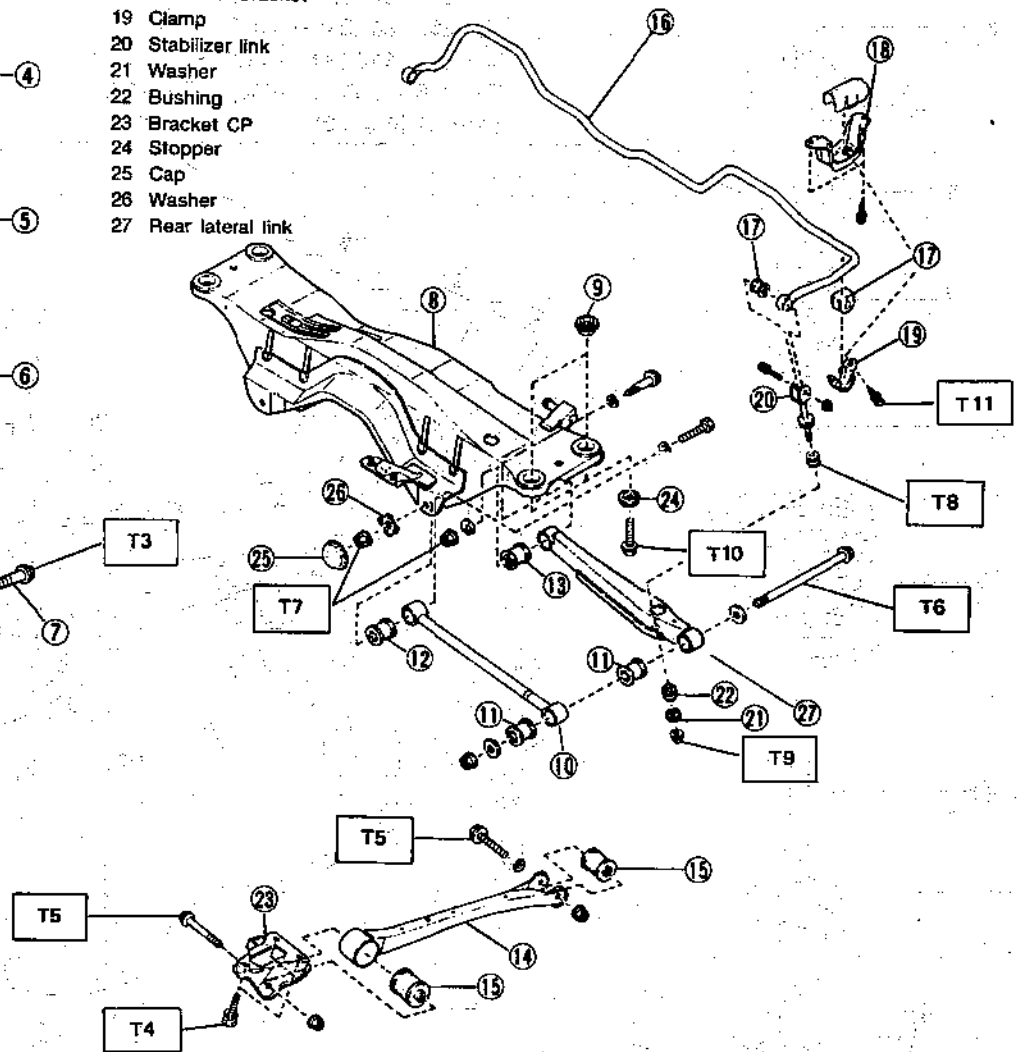


Fig. 22

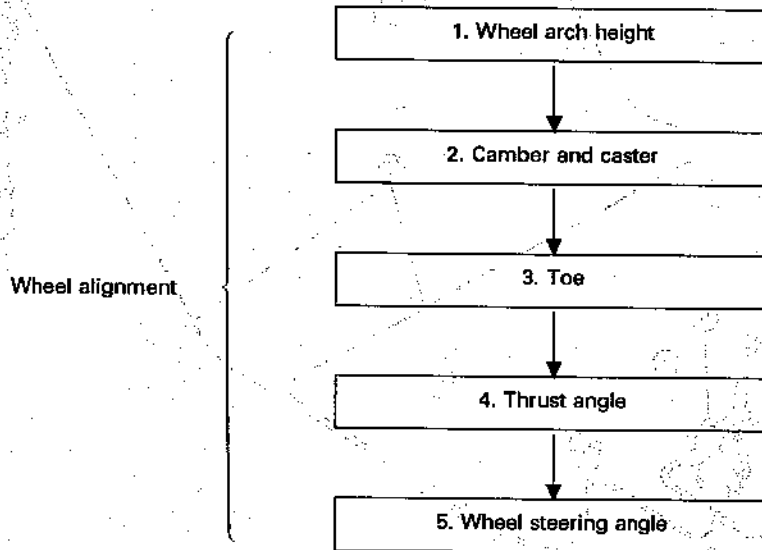
B4-1418

W SERVICE PROCEDURE FOR CONVENTIONAL SUSPENSION

1. On-car Services

A: WHEEL ALIGNMENT

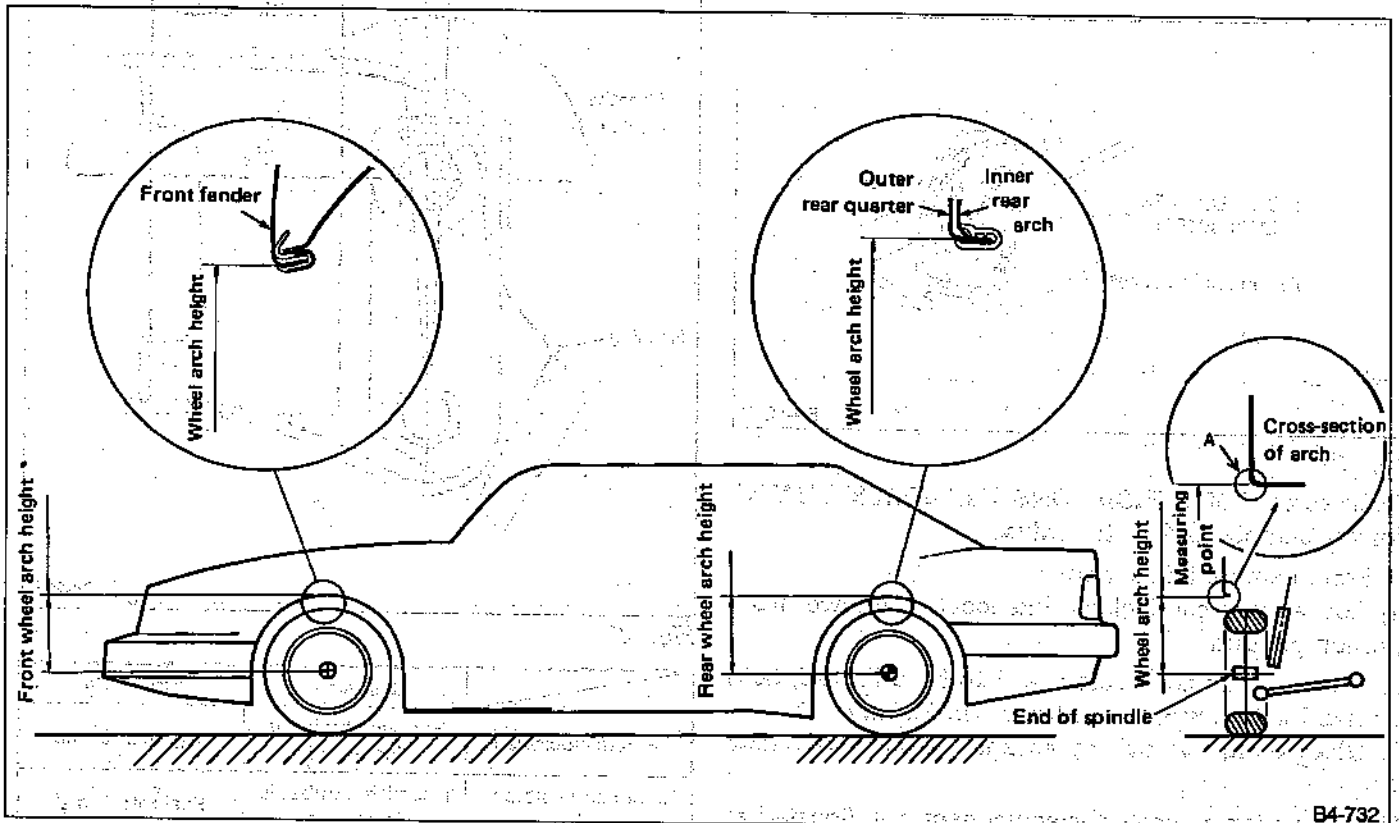
Check, adjust and/or measure wheel alignment in accordance with procedures indicated below:



1. WHEEL ARCH HEIGHT

- 1) Inflate tire pressure to specifications.
- 2) Set vehicle under "curb weight" conditions. (Empty luggage compartment, install spare tire, jack, service tools, and top up fuel tank.)
- 3) Set steering wheel in a wheel-forward position.

- 4) Suspend thread from wheel arch (point "A" in figure below) to determine a point directly above center of spindle.
- 5) Measure distance between measuring point and center of spindle.



B4-732

Fig. 26

Vehicles		Specified wheel arch height mm (in)	
		Front	Rear
Sedan	FWD	378 ± 10 (14.88 ± 0.39)	359 ± 10 (14.13 ± 0.39)
		*388 ± 10 (15.28 ± 0.39)	*369 ± 10 (14.53 ± 0.39)
	4WD	388 ± 10 (15.28 ± 0.39)	369 ± 10 (14.53 ± 0.39)
	TURBO	378 ± 10 (14.88 ± 0.39)	364 ± 10 (14.33 ± 0.39)
Wagon	FWD	378 ± 10 (14.88 ± 0.39)	369 ± 10 (14.53 ± 0.39)
	4WD	388 ± 10 (15.28 ± 0.39)	379 ± 10 (14.92 ± 0.39)
	TURBO	378 ± 10 (14.88 ± 0.39)	364 ± 10 (14.33 ± 0.39)
	** Air suspension model	388 ± 10 (15.28 ± 0.39)	369 ± 10 (14.53 ± 0.39)

*: 2200 cc model

** : "Normal" position

2. CAMBER AND CASTER

• Inspection

- 1) Place the wheel to be measured on the turning radius gauge, and make sure the vehicle is level.
- 2) Set ADAPTER (927380000) into the center of the wheel, and then install the alignment gauge.

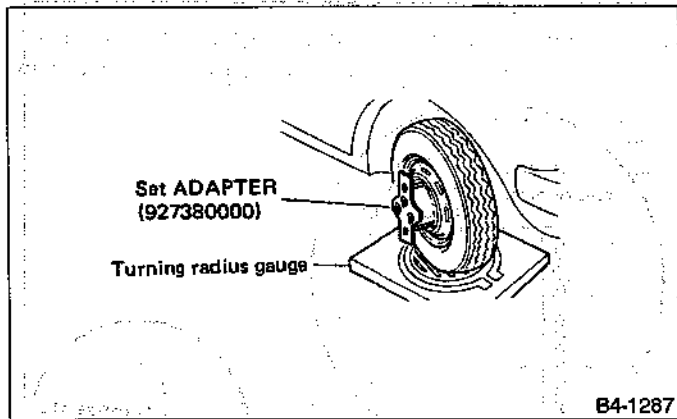


Fig. 27

Refer to the "SPECIFICATIONS AND SERVICE DATA" for the camber and caster values.

• Front camber adjustment

- 1) Loosen two self-locking nuts located at lower front portion of strut.
 - a. When adjustment bolt needs to be adjusted, hold its head with a wrench and turn self-locking nut.
 - b. Discard old self-locking nut and replace with a new one.
- 2) While aligning scale for adjustment bolt (located at rear of vehicle) with mark on strut bracket, set camber angle within proper specifications.

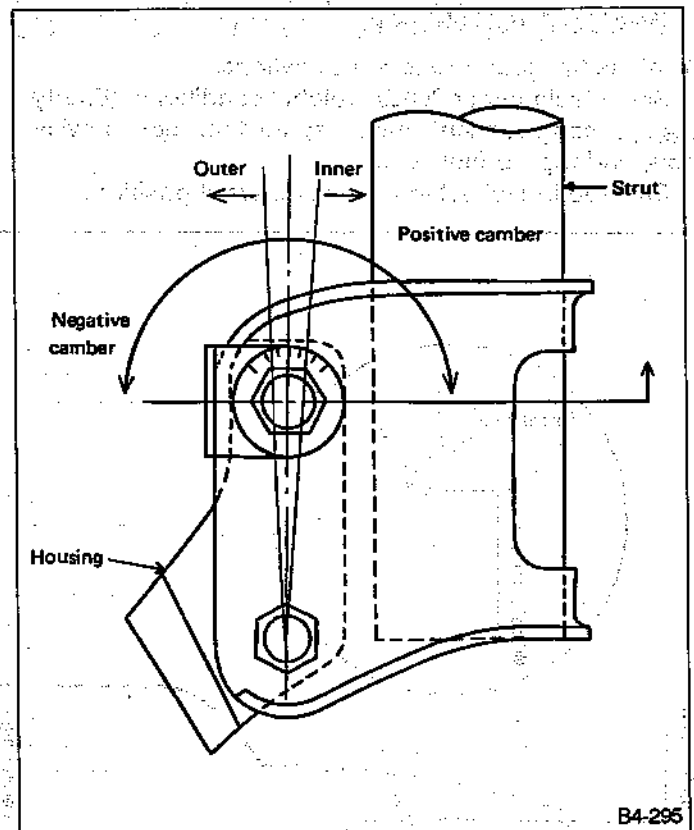


Fig. 28

	Left side	Right side
Rotate clockwise	Positive camber is increased	Negative: Same
Rotate counterclockwise	Negative camber is increased	Positive: Same

- 3) Tighten two self-locking nuts.

Tightening torque:

132 — 172 N·m (13.5 — 17.5 kg-m, 98 — 127 ft-lb)

3. FRONT WHEEL TOE-IN AND TOE-OUT

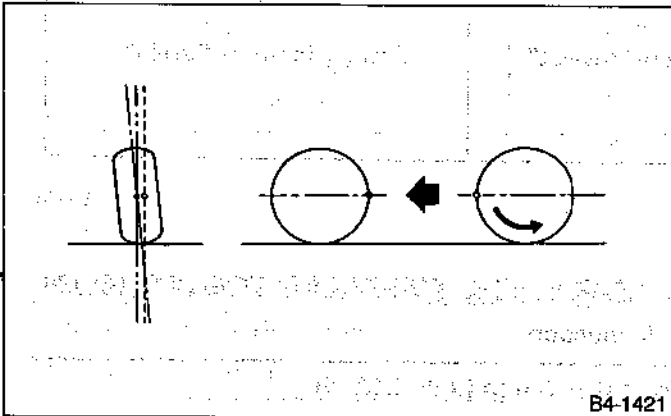
● Inspection

Using a toe gauge, measure front wheel toe-in or toe-out.

Toe : 0 ± 3 mm (0 ± 0.12 in)

When using a toe-gauge, make sure to measure as follow;

Move vehicle forward until wheels rotate exactly 180° as shown in the figure.



B4-1421

Fig. 29

● Adjustment

- 1) Loosen the left and right side rod lock nuts.
- 2) Turn the left and right tie rods equal amounts until the toe-in is within the specified range.

Both the left and right tie-rods are right-hand threaded. To increase toe-in, turn both tie-rods counterclockwise equal amounts (as viewed from the outside of the vehicle).

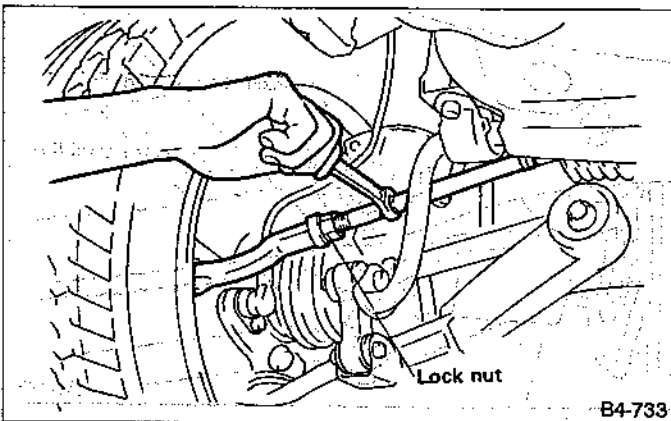


Fig. 30

- 3) Tighten tie-rod lock nut.

Tightening torque:

78 — 88 N·m (8 — 9 kg-m, 58 — 65 ft-lb)

- a. Check that left and right wheel steering angle is within specifications.
- b. Correct tie-rod boot if twisted.

4. REAR WHEEL TOE-IN AND TOE-OUT

● Inspection

Using a toe gauge, measure rear wheel toe-in and toe-out.

Toe : 0 ± 3 mm (0 ± 0.12 in)

● Adjustment

- 1) Remove cap from lateral link and loosen self-locking nut.

a. When loosening or tightening adjustment bolt, hold bolt head and loosen self-locking nut.

b. Replace self-locking nut with a new one.

- 2) Using two wrenches, turn adjustment wheel and adjustment bolt equally in opposite directions so that toe-in and toe-out are within proper specifications.

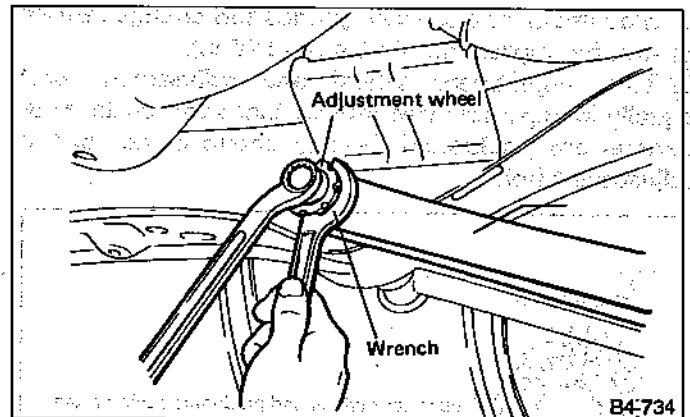
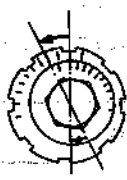
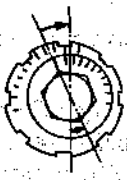


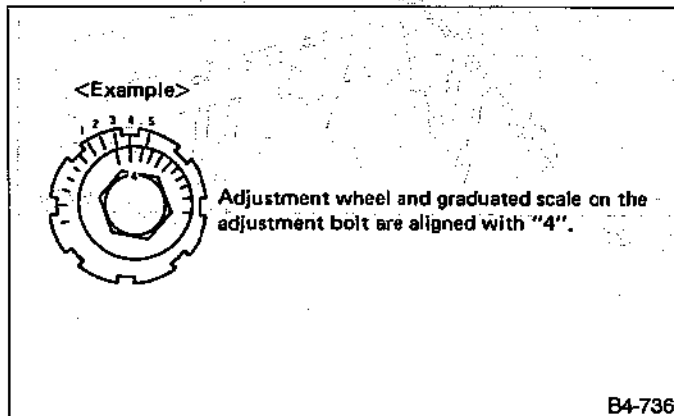
Fig. 31

Rotation direction of adjustment wheel and adjustment bolt	Left wheel toe-in and toe-out	Right wheel toe-in and toe-out
	Changes for more "toe-in"	Changes for more "toe-out"
	Changes for more "toe-out"	Changes for more "toe-in"

B4-735

Fig. 32

- Movement of one scale graduation changes toe-in or -out by approximately 4 mm (0.16 in).
- Turn adjustment wheel and adjustment bolt equally in opposite directions so that same scale graduations are positioned directly above center of the adjustment bolt.



B4-736

Fig. 33

- Tighten self-locking nut.

Tightening torque:

118 — 157 N·m (12 — 16 kg·m, 87 — 116 ft·lb)

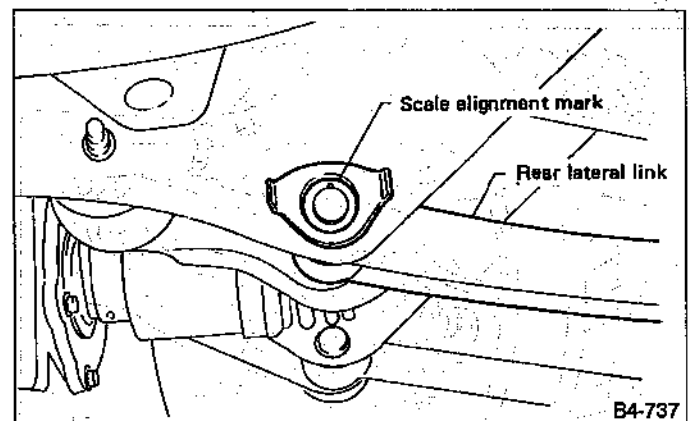
5. REAR WHEEL TOE-IN AND TOE-OUT (4WD)

- Inspection

Toe : 0 ± 3 mm (0 ± 0.12 in)

- Adjustment

- Loosen self-locking nut on rear lateral link.
 - When loosening or tightening adjustment bolt, hold bolt head and turn self-locking nut.
 - Replace self-locking nut with a new one.
- Turn adjustment bolt head until toe-in and -out are within specifications.



B4-737

Fig. 34

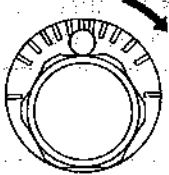
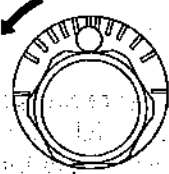
Rotation direction of adjustment bolt	Toe-in/-out of left wheel	Toe-in/-out of right wheel
	Changes for more "toe-in"	Changes for more "toe-out"
	Changes for more "toe-out"	Changes for more "toe-in"

Fig. 35

B4-738

Movement of one scale graduation changes toe-in or -out by approximately 3 mm (0.12 in).

3) Tighten self-locking nut.

Tightening torque:

83 — 113 N·m (8.5 — 11.5 kg·m, 61 — 83 ft·lb)

6. THRUST ANGLE

• Inspection

- 1) Position vehicle on a level surface.
- 2) Move vehicle 3 to 4 meters directly forward.
- 3) Determine locus of both front and rear axles.
- 4) Measure difference "L" between locus on the axles.

(For reference)

Thrust angle is less than 20' when "L" is equal to or less than 15 mm.

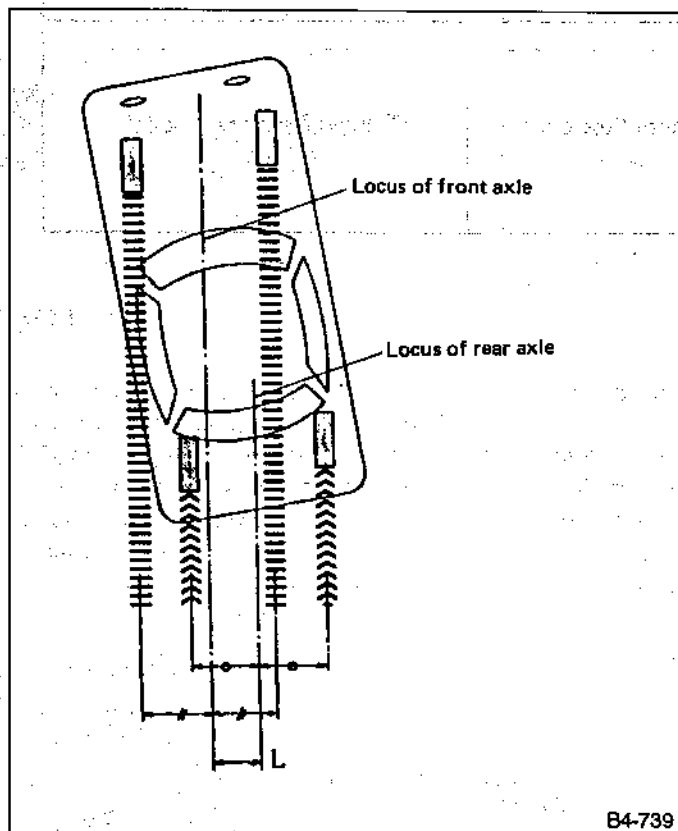


Fig. 36

• Adjustment

Make thrust angle adjustments for left and right rear wheels by turning toe-in and -out adjustment bolts or adjustment wheels (for FWD models) equally in the same direction.

(For reference)

- When one rear wheel is adjusted in a toe-in direction, adjust the other rear wheel equally in toe-out direction, in order to make thrust angle adjustment.

- When left and right adjustment bolts are turned incrementally in the same direction (except for FWD models), the thrust angle will change approximately 10' ["L" is nearly equal to 7.5 mm (0.295 in)]. On FWD models, adjustment wheels must be turned by the same amount in opposite directions.

Standard thrust angle:

Less than $\pm 20'$

7. STEERING ANGLE

• Inspection

- 1) Place vehicles on a turning radius gauge.
- 2) While depressing brake pedal, turn steering wheel fully to the left and right. With steering wheel held at each fully turned position, measure both the inner and outer wheel steering angle.

Steering angle	Non TURBO	TURBO
Inner wheel	$39^{\circ} + 1^{\circ}$ $- 1.5^{\circ}$	$36.5^{\circ} + 1^{\circ}$ $- 1.5^{\circ}$
Outer wheel	$33.5^{\circ} + 1^{\circ}$ $- 1.5^{\circ}$	$32.0^{\circ} + 1^{\circ}$ $- 1.5^{\circ}$

• Adjustment

Turn tie-rod to adjust steering angle of both inner and outer wheels.

- a. Check toe-in and -out.
- b. Correct boot if twisted.

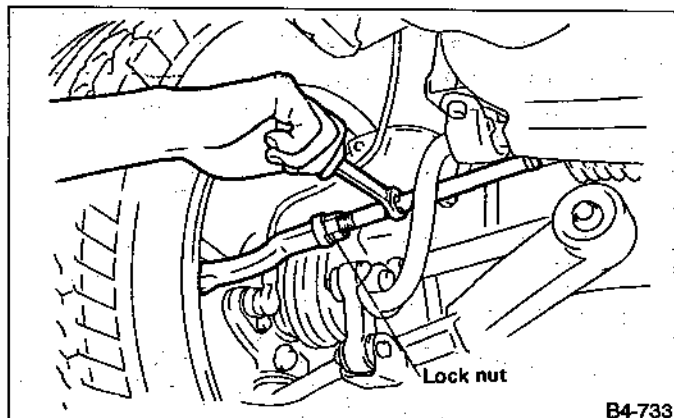


Fig. 37

2. Front Transverse Link Assembly

A: REMOVAL

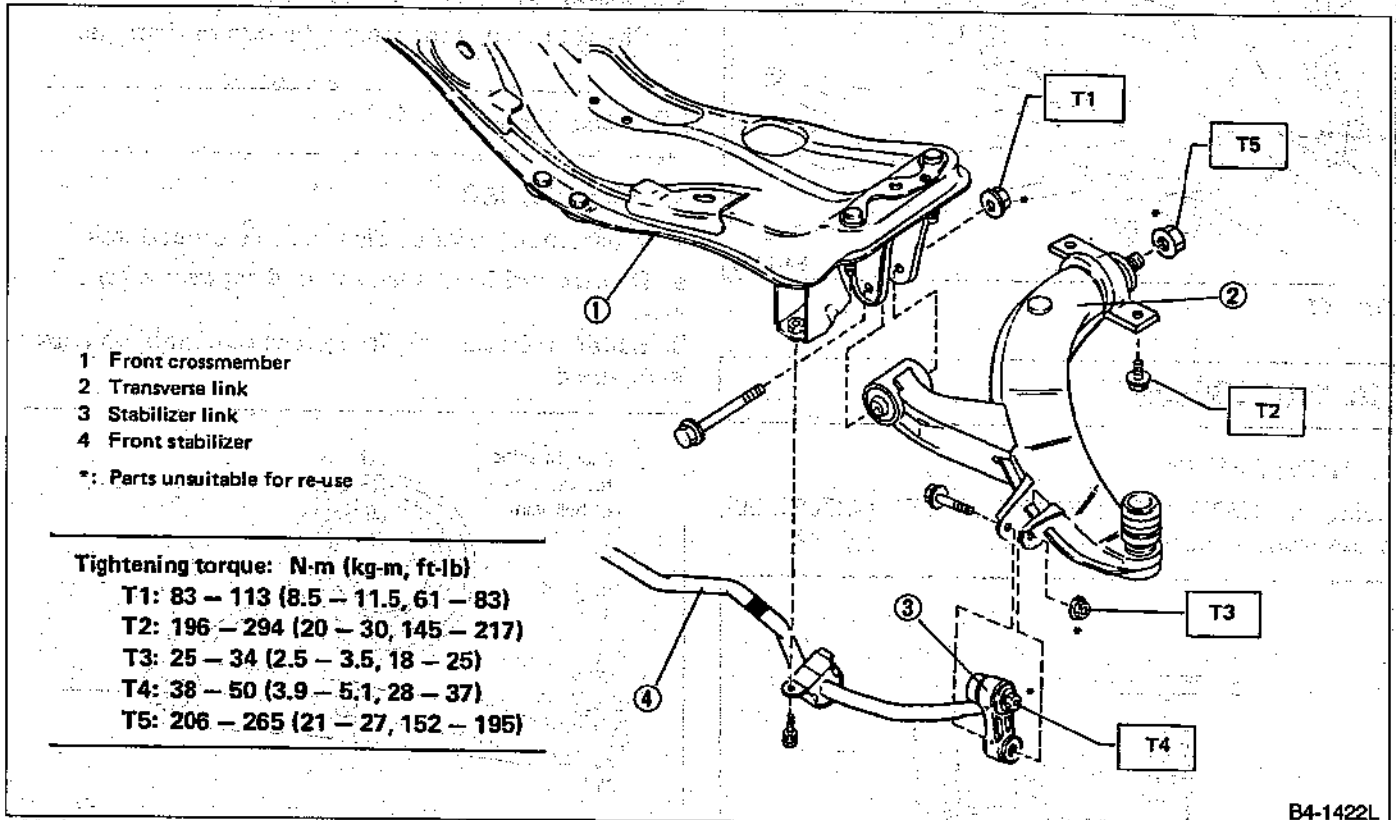


Fig. 38

- 1) Disconnect transverse link and stabilizer link.
- 2) Disconnect housing and ball joint.

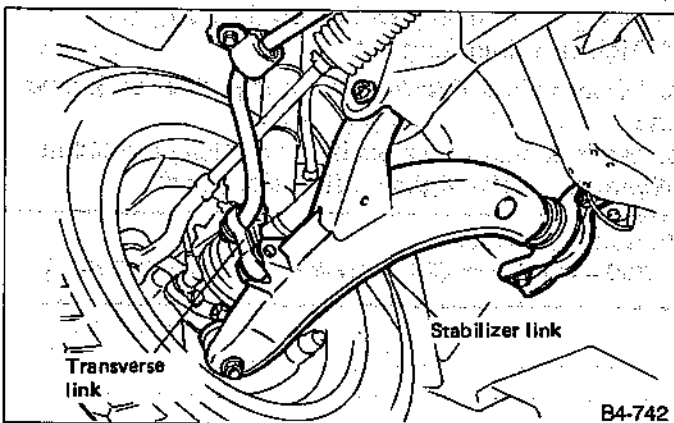


Fig. 39

- 3) Remove nuts (do not remove bolts) securing transverse link to crossmember.
- 4) Remove two bolts securing rear of transverse link to car body at bushing location.

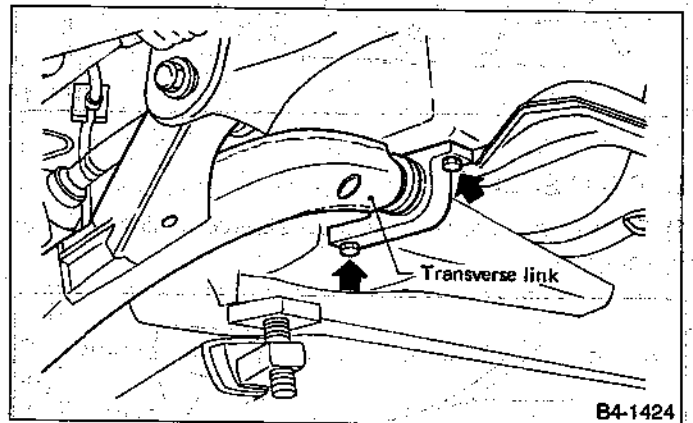


Fig. 40

- 5) Extract ball joint from housing.
- 6) Remove bolts securing transverse link to crossmember and lower transverse link to floor.

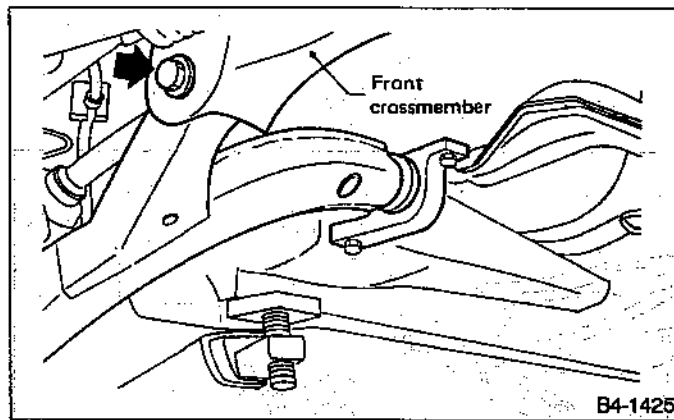


Fig. 41

B: DISASSEMBLY

1. FRONT BUSH

Using an INSTALLER & REMOVER SET (927680000), press front bushing out of place.

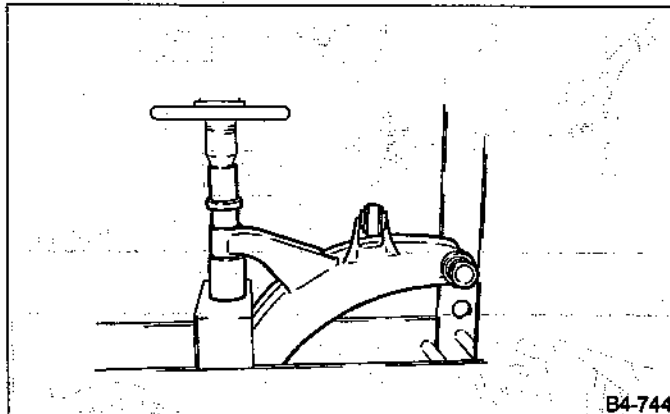


Fig. 42

2. REAR BUSH

1) Scribe an alignment mark on transverse link and rear bushing.

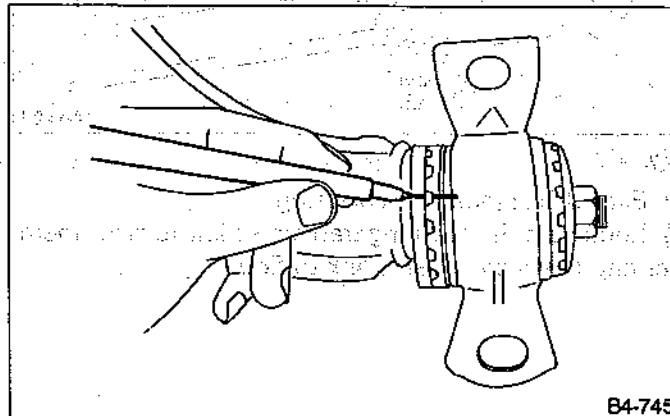


Fig. 43

2) Loosen nut and remove rear bushing.

C: INSPECTION

- 1) Check transverse link for wear, damage and cracks, and correct or replace if defective.
- 2) Check bushings for cracks, fatigue or damage.

D: ASSEMBLY

1. FRONT BUSH

To reassemble, reverse disassembly procedures.

- a. Discard old front bushing and replace with a new one.
- b. Install front bushing in correct direction, as shown in Figure 44.

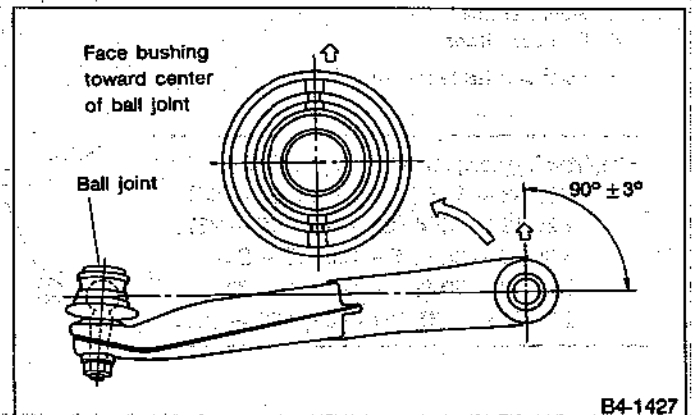


Fig. 44

2. REAR BUSH

- 1) Insert rear bushing into bore in transverse link and align alignment marks scribed on the two.
- 2) Tighten self-locking nut.

- a. Discard old self-locking nut and replace with a new one.
- b. While holding rear bushing to change position of alignment marks, tighten self-locking nut.

Tightening torque:

206 — 265 N·m (21 — 27 kg-m, 152 — 195 ft-lb)

E: INSTALLATION

1) Temporarily tighten two bolts located behind the transverse link at bushing location.

These bolts should be tightened to such an extent that they can still move back and forth in the oblong shaped hole in the bracket (which holds the bushing).

2) Install bolts used to connect transverse link and crossmember and temporarily tighten with nuts.

Self-lock nut must be replaced with a new one whenever it is removed.

3) Insert ball joint into housing.

4) Connect stabilizer link to transverse link, and temporarily tighten bolts.

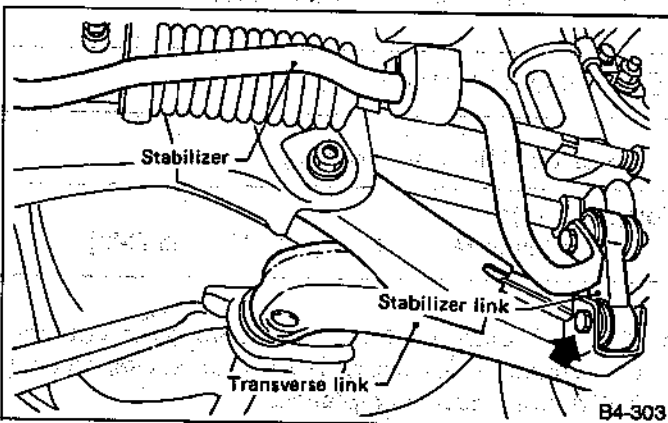


Fig. 45

Self-lock nut must be replaced with a new one whenever it is removed.

5) Tighten the following points in the order shown below when vehicle is empty and wheels are firmly on the ground.

- (1) Transverse link and stabilizer

Tightening torque:

25 — 34 N·m (2.5 — 3.5 kg-m, 18 — 25 ft-lb)

- (2) Transverse link and crossmember

Tightening torque:

83 — 113 N·m (8.5 — 11.5 kg-m, 61 — 83 ft-lb)

- (3) Transverse link rear bushing and body

Tightening torque:

196 — 294 N·m (20 — 30 kg-m, 145 — 217 ft-lb)

Move rear bushing back and forth until transverse link-to-rear bushing clearance is established (as indicated in Figure 46.) before tightening.

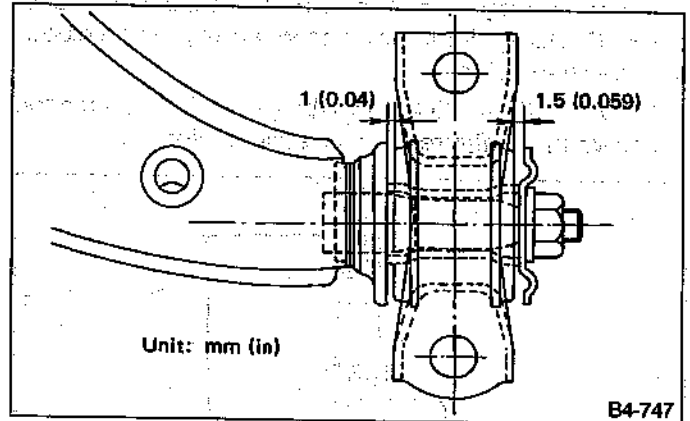


Fig. 46

3. Front Ball Joint

A: REMOVAL

- 1) Remove the wheels.
- 2) Pull out the cotter pin from the ball stud, remove the castle nut, and remove the ball stud from the transverse link.

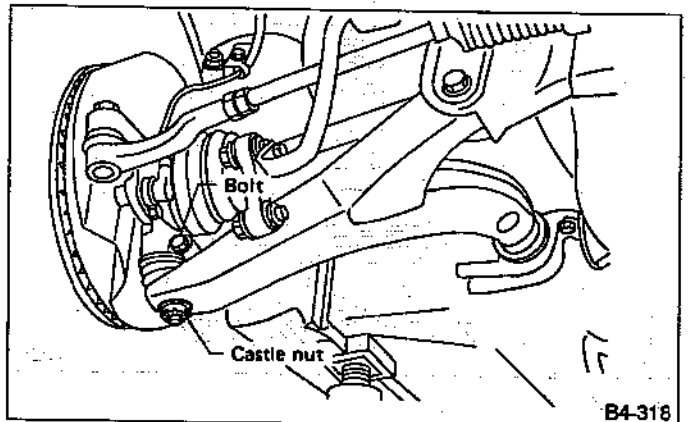


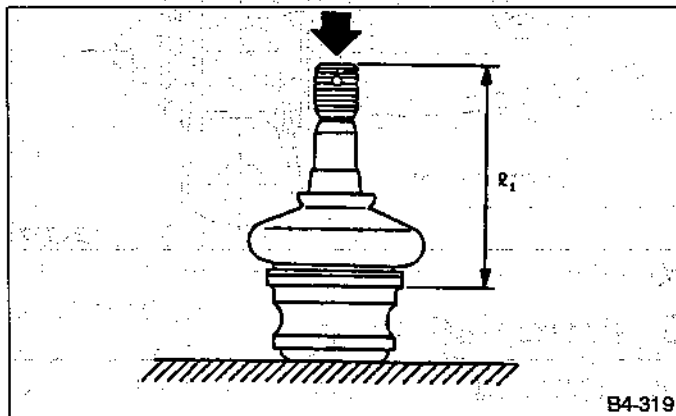
Fig. 47

- 3) Remove the bolt securing the ball joint to the housing.
- 4) Remove the ball joint from the housing.

B: INSPECTION

1) Measure play of ball joint by the following procedures. Replace with a new one when the play exceeds the specified value.

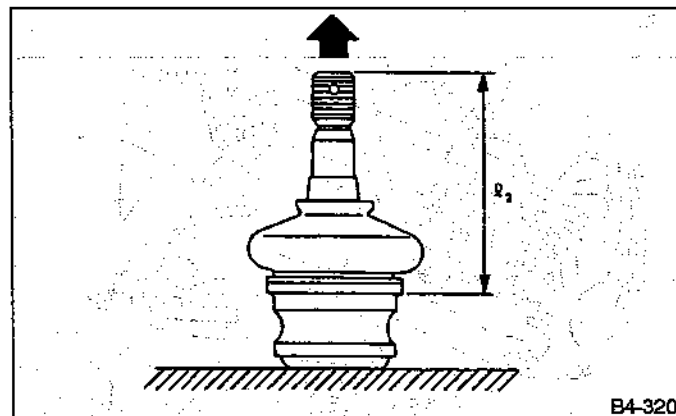
(1) With 686 N (70 kg, 154 lb) loaded in the direction shown in the figure, measure dimension l_1 .



B4-319

Fig. 48

(2) With 686 N (70 kg, 154 lb) loaded in the direction shown in the figure, measure dimension l_2 .



B4-320

Fig. 49

(3) Calculate plays from the following formula.

$$S = l_2 - l_1$$

(4) When plays is larger than the following figure, replace with a new one.

FRONT BALL JOINT

Specified play for replacement: S
More than 0.3 mm (0.012 in)

2) When play is smaller than the specified value, visually inspect the dust seal.

3) If the dust seal is damaged, remove it and wipe off any deteriorated grease with a clean cloth.

4) Next, replace with an appropriate quantity of specified grease (SUNLIGHT 2; P/N 003602010), about 3 g (0.11 oz), then mount a new dust seal.

C: INSTALLATION

1) Install ball joint onto housing.

Torque (Bolt):

39 — 59 N·m (4.0 — 6.0 kg-m, 29 — 43 ft-lb)

a. The ball joint and boot that have been removed must be checked for wear, damage or cracks, and any defective part must be replaced.

b. Do not apply grease to tapered portion of ball stud.

2) Connect ball joint to transverse link.

Torque (Castle nut):

39 N·m (4.0 kg-m, 29 ft-lb)

3) Retighten castle nut further within 60° until a slot in castle nut is aligned with the hole in ball stud end, then insert new cotter pin and bend it around castle nut.

4) Install front wheels, and lower vehicle.

4. Front Strut Assembly

A: REMOVAL

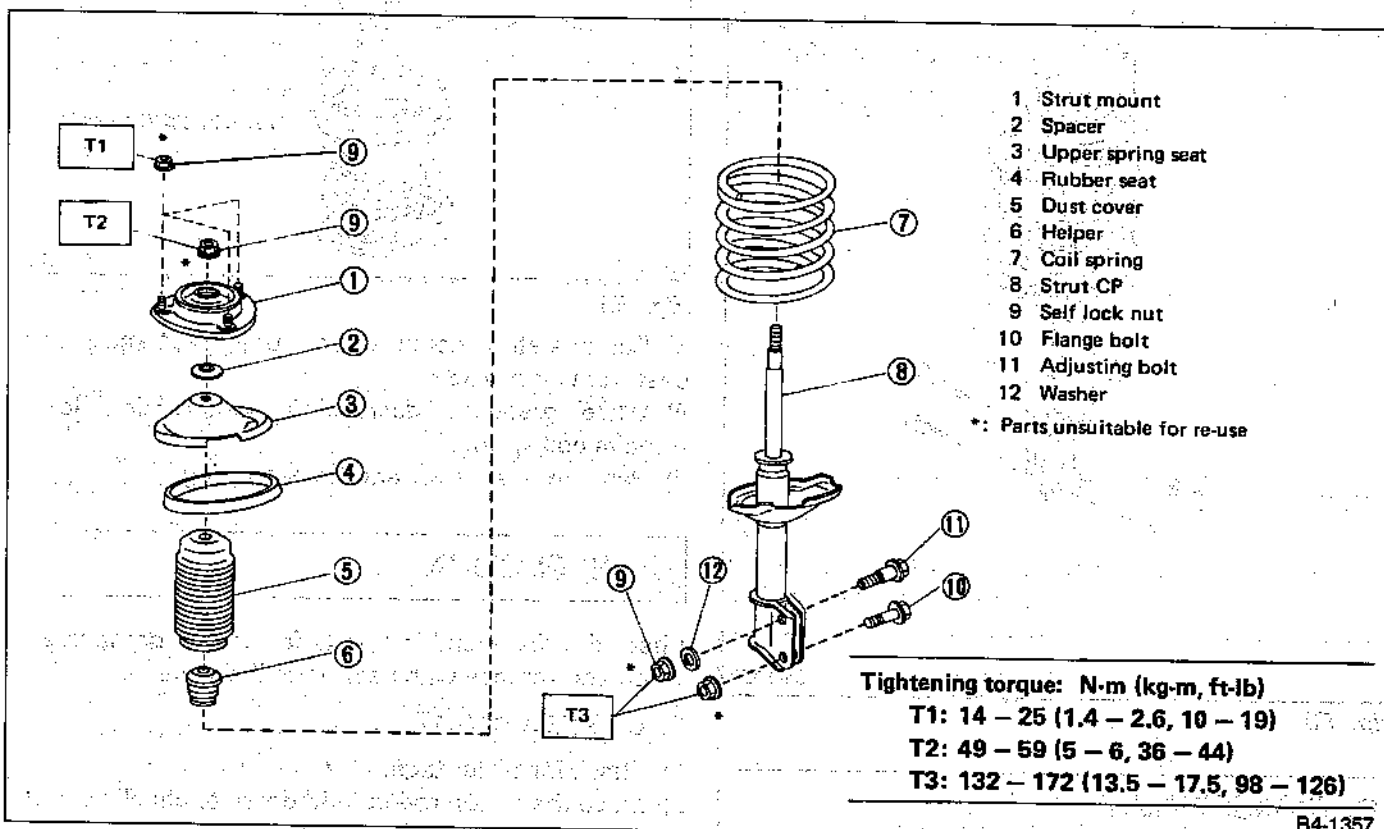


Fig. 50

B4-1357

- 1) Disconnect ground cable from battery.
- 2) Remove wheel.
- 3) Depress brake pedal and hold it down using a wooden block.
- 4) Remove union bolts from caliper.

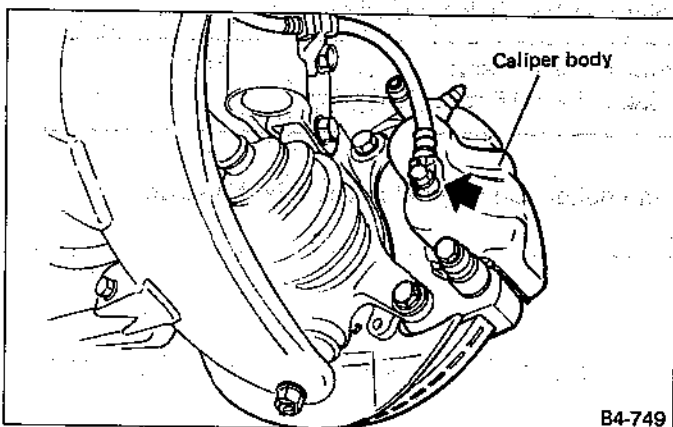


Fig. 51

B4-749

Use brake hose cap to prevent brake fluid from escaping.

- 5) Remove brake hose clamp and disconnect brake hose from strut. Attach brake hose to strut using gum tape.

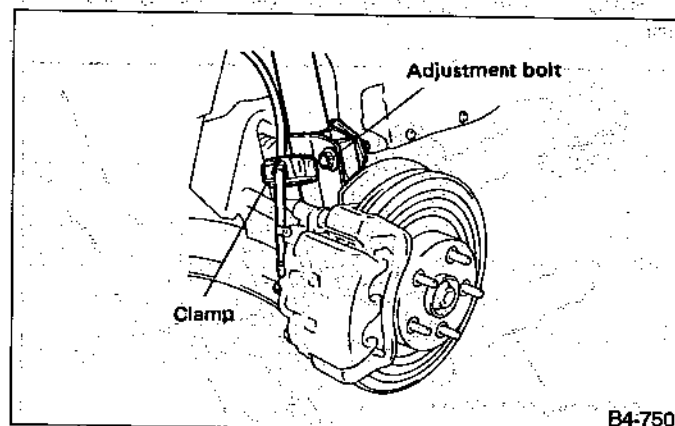


Fig. 52

B4-750

- 6) Scribe an alignment mark on the camber adjustment bolt which secures strut to housing.
- 7) Remove bolt securing the ABS sensor harness on models equipped with ABS.
- 8) Remove two bolts securing housing to strut. While holding head of adjustment bolt, loosen self-locking nut.
- 9) Remove the three nuts.

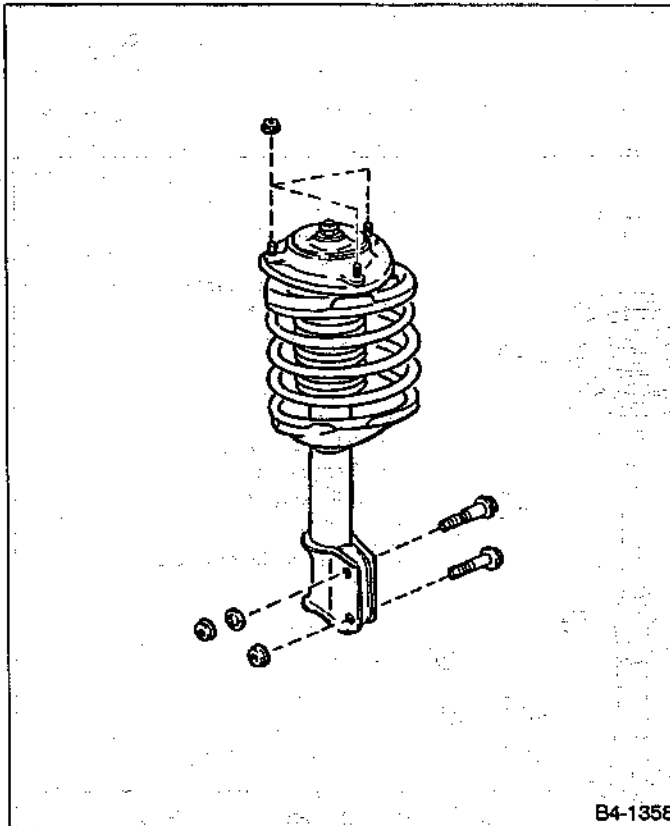


Fig. 53

B: DISASSEMBLY

- 1) Using a coil spring compressor, compress coil spring.

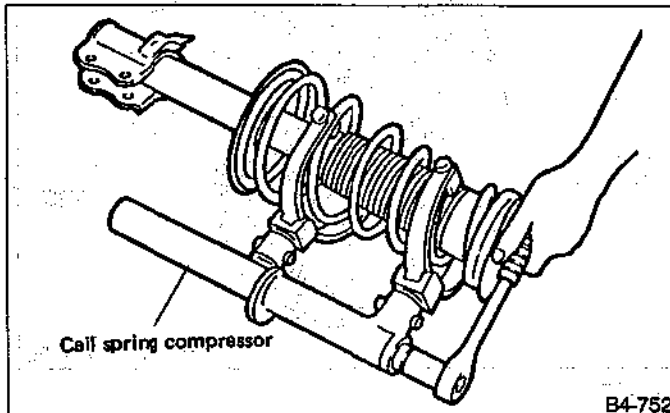


Fig. 54

- 2) Using STRUT MOUNT SOCKET (927760000), remove self-locking nut.

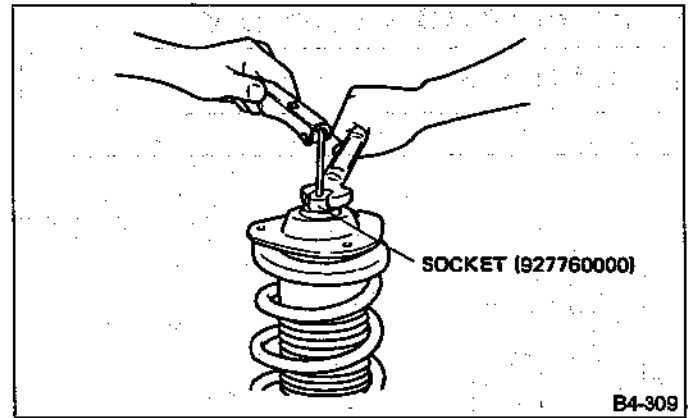


Fig. 55

- 3) Remove strut mount, upper spring seat and rubber seat from strut ASSY.
- 4) While gradually decreasing compression force, remove coil spring.
- 5) Remove dust cover and helper spring.

C: INSPECTION

Check the disassembled parts for cracks, damage and wear, and replace with new parts if defective.

1. DAMPER STRUT

- 1) Check for oil leakage.
- 2) Move the piston rod up and down to check its operates smoothly without any binding.
- 3) Deflection of piston rod

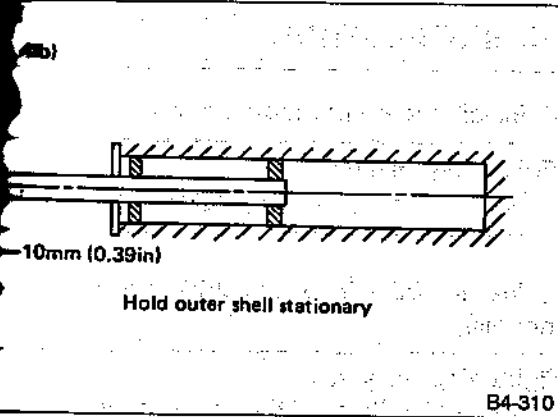
Measure the deflection as follows:

Fix the outer shell and fully extend the rod. Set a dial gauge at the end of the rod, and apply a weight of ± 20 N (± 2 kg, ± 4 lb) to the threaded portion. Read the dial gauge indication. The amplitude of the gauge needle pointer is the deflection of the rod.

Limit of deflection:

Less than 0.8 mm (0.031 in)

If the deflection is greater, replace the strut.



OUT MOUNT

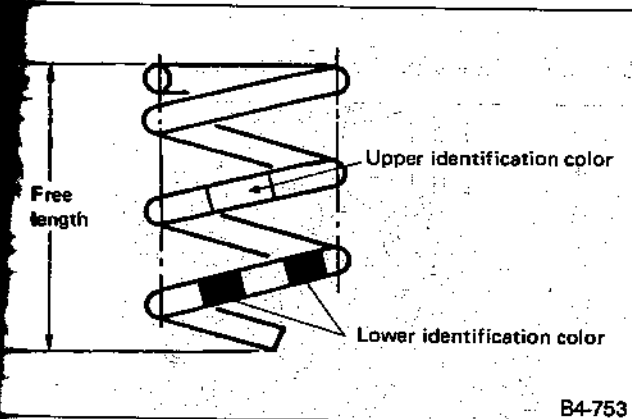
rubber part for creep, cracks and distortion, and replace it with new one if defective. Distortion is found on its connecting surface to replace it with a new one.

ST COVER

cracks or damage are found, replace it with a new

IL SPRING

iving permanent strain should be replaced with a ne. When vehicle posture is uneven, although are no considerable reasons like tire puncture, a loading, etc., check coil spring for its free a, cracks, etc., referring to specifications, and e it with a new one if defective.



57

HELPER

place it with new one if cracked or damaged.

D: ASSEMBLY

1) Compress the coil spring.

Make sure that the vertical installing direction of coil spring is as shown below.

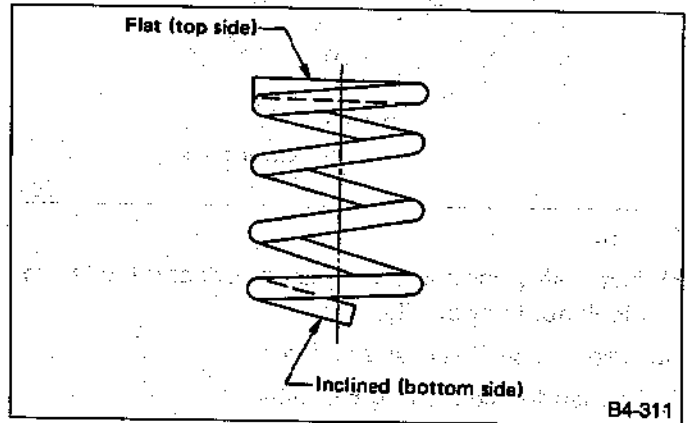


Fig. 58

2) Set the coil spring correctly so that its end face fits well into the spring seat as shown.

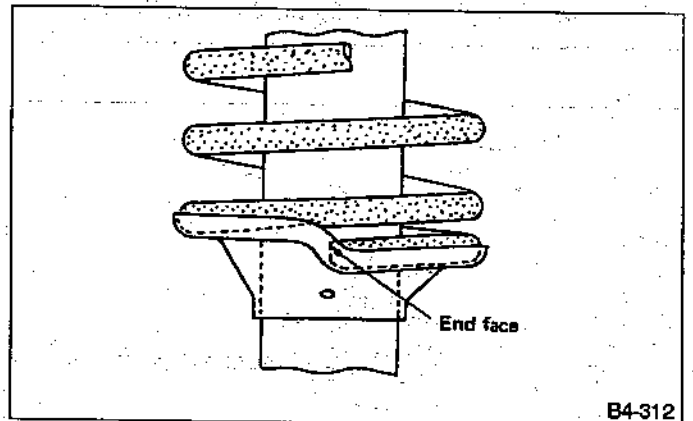


Fig. 59

3) Install helper and dust cover to the piston rod.

4) Pull the piston rod fully upward, and install rubber seat and spring seat.

Ensure that upper spring seat is positioned with "OUT" mark facing outward.

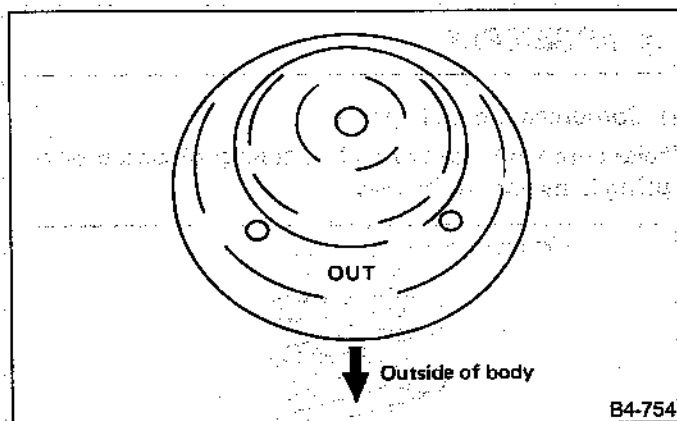


Fig. 60

5) Install strut mount to the piston rod, and tighten the self-lock nut temporarily.

Be sure to use a new self-lock nut.

6) Loosen the coil spring carefully.

7) While fixing the spring seat, tighten the self-lock nut with SOCKET (927760000).

Tightening torque:

49 — 69 N·m (5.0 — 7.0 kg-m, 36 — 51 ft-lb)

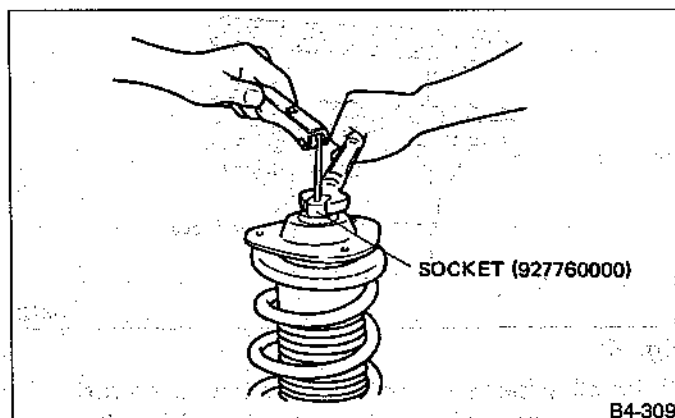


Fig. 61

E: INSTALLATION

1) Install upper strut mount and tighten with bolts.

Tightening torque:

14 — 25 N·m (1.4 — 2.6 kg-m, 10 — 19 ft-lb)

2) Install ABS sensor attaching bolts. (ABS-equipped models)

Tightening torque:

132 — 172 N·m (13.5 — 17.5 kg-m, 98 — 127 ft-lb)

3) Position alignment mark on camber adjustment bolt with alignment mark on lower side of strut.

a. While holding head of adjustment bolt, tighten self-locking nut.

b. **Be sure to use new self-lock nut.**

Tightening torque:

132 — 172 N·m (13.5 — 17.5 kg-m, 98 — 127 ft-lb)

4) Tighten brake hose on lower side of strut with clamp.

5) Install union bolts which secure brake caliper to brake hose.

Tightening torque:

15 — 21 N·m (1.5 — 2.1 kg-m, 11 — 15 ft-lb)

Be sure to bleed air from brake system.

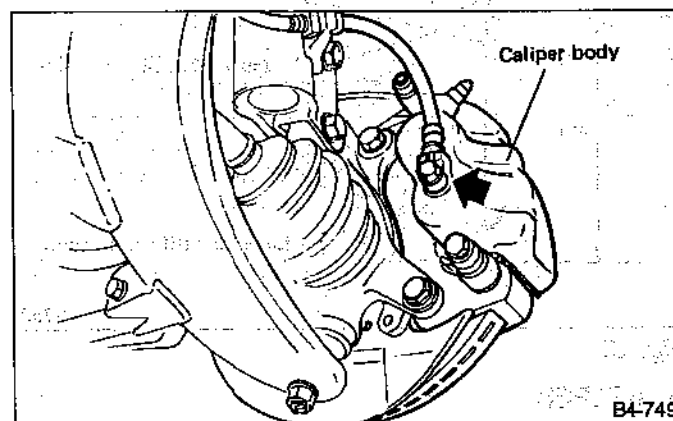
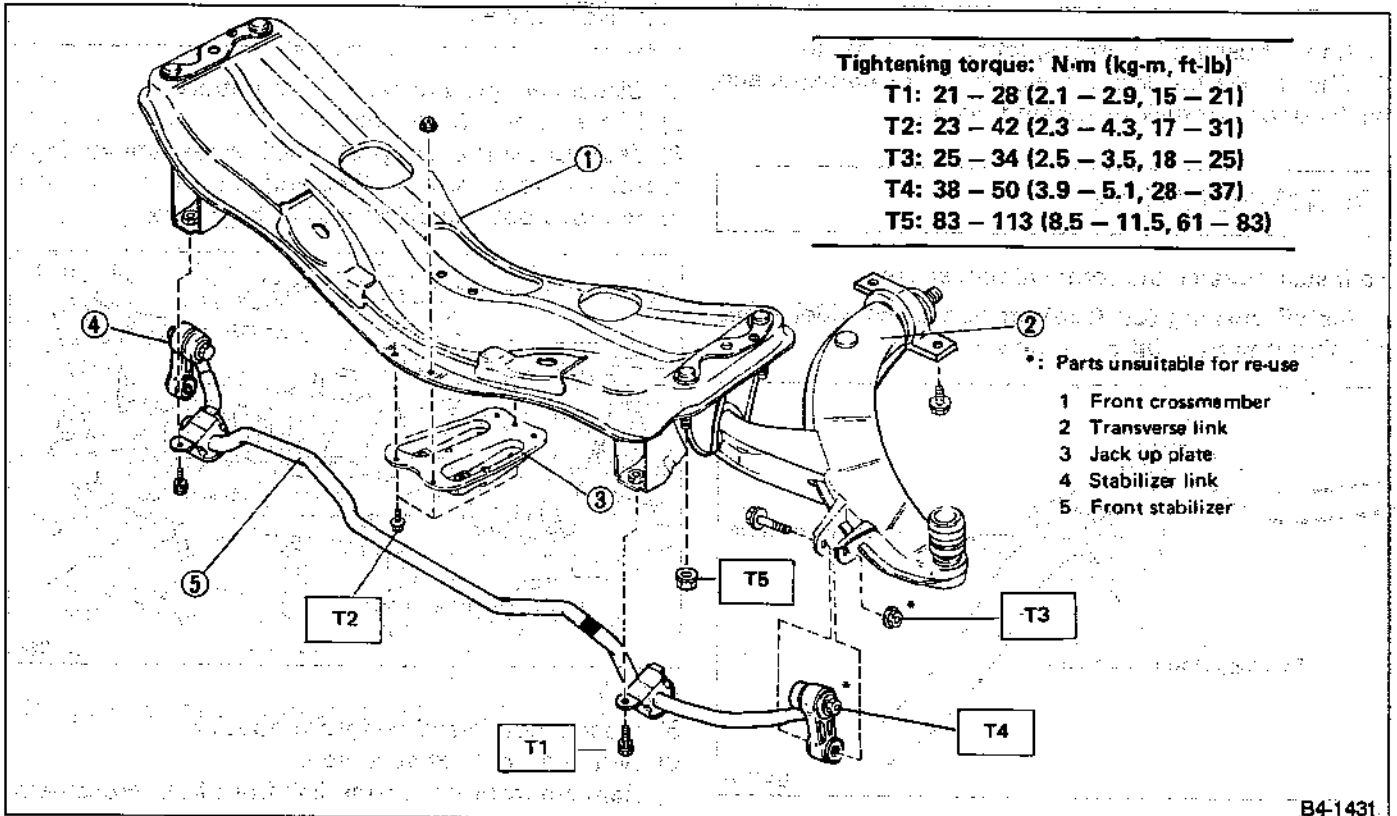


Fig. 62

6) Install wheels and connect ground cable to negative terminal of battery.

5. Front Stabilizer



B4-1431

Fig. 63

A: REMOVAL

- 1) Jack up the front part of the vehicle.
- 2) Remove bolts which secure crossmember to stabilizer.

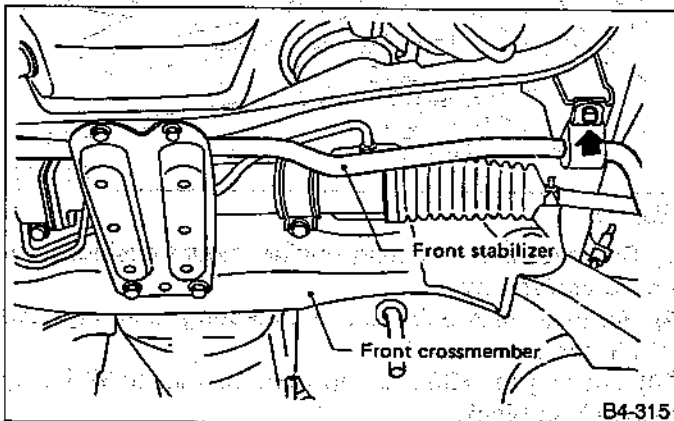


Fig. 64

- 3) Remove bolts which secure stabilizer link to front transverse link ASSY.

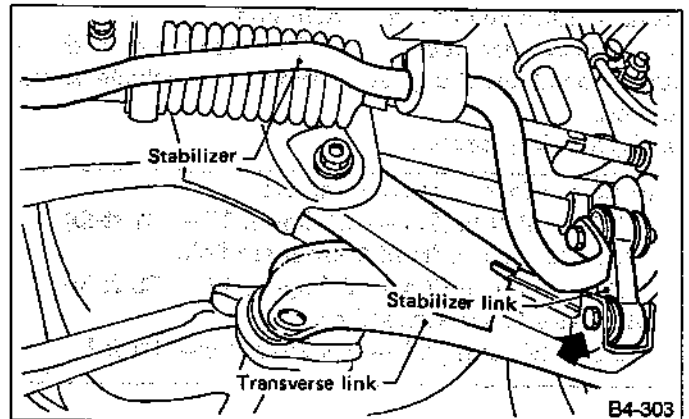


Fig. 65

- 4) Remove jack up plate from lower part of crossmember.

B: INSPECTION

- 1) Check bushing for cracks, fatigue or damage.
- 2) Check links for deformities, cracks, or damage, and bushing for protrusions beyond clamp.

C: INSTALLATION

To install, reverse the removal procedure.

- a. Install bushing (on front crossmember side) while aligning it with paint mark on stabilizer.

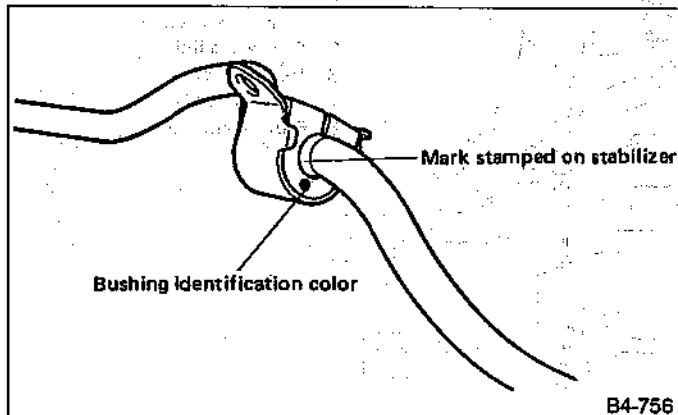


Fig. 66

- b. Ensure that bushing and stabilizer have the same identification colors when installing.
- c. Fit each bush securely, and tighten bolts with the tires placed on the ground when the vehicle is not loaded.

d. Tightening torque:

Jack up plate to crossmember:	23 — 42 N·m (2.3 — 4.3 kg-m, 17 — 31 ft-lb)
Stabilizer link to front transverse link:	25 — 34 N·m (2.5 — 3.5 kg-m, 18 — 25 ft-lb)
Stabilizer to crossmember:	21 — 28 N·m (2.1 — 2.9 kg-m, 15 — 21 ft-lb)

6. Front Crossmember**A: REMOVAL**

- 1) Disconnect ground cable from battery.
- 2) Loosen front wheel nuts.
- 3) Jack up vehicle, support it with safety stands (rigid racks), and remove front tires and wheels.
- 4) Remove both stabilizer and jack-up plate.

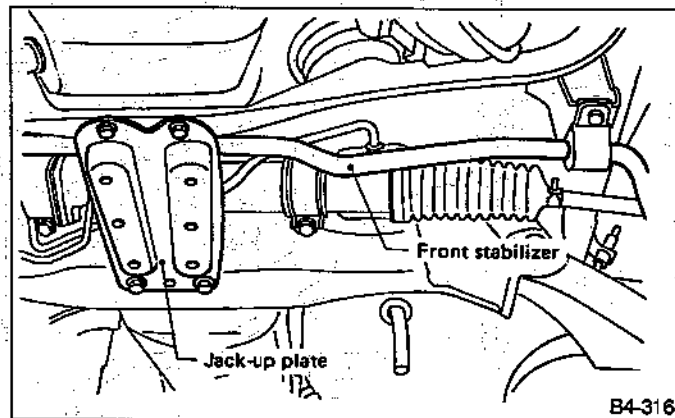


Fig. 67

- 5) Disconnect tie-rod end from housing.
- 6) Remove front exhaust pipe.
- 7) Remove front transverse link from front crossmember.

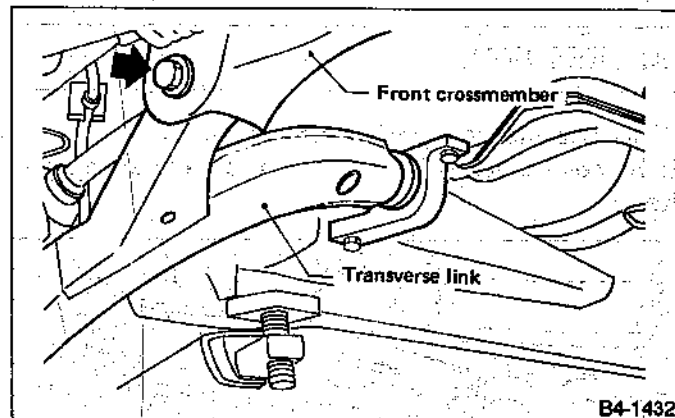


Fig. 68

- 8) Remove nuts attaching engine mount cushion rubber to crossmember.
- 9) Remove self-lock nuts connecting steering U/J ASSY and pinion shaft.
- 10) Lift engine ASSY by approx. 10 mm (0.39 in) by using chain block.
- 11) Remove crossmember installing nuts with crossmember supported by jack, and lower crossmember gradually along with steering gearbox.

When removing crossmember downward, be careful that tie-rod end does not interfere with DOJ boot.

B: INSTALLATION

Installation is in the reverse order of removal procedures.

a. Always tighten transverse link and stabilizer when wheels are in full contact with the ground and vehicle is curb weight.

b. Tightening torque

Transverse link bushing to crossmember:

83 — 113 N•m (8.5 — 11.5 kg-m, 61 — 83 ft-lb)

Stabilizer to bush:

21 — 28 N•m (2.1 — 2.9 kg-m, 15 — 21 ft-lb)

Tie-rod end to housing:

25 — 29 N•m (2.5 — 3.0 kg-m, 18 — 22 ft-lb)

Front cushion rubber to crossmember:

54 — 83 N•m (5.5 — 8.5 kg-m, 40 — 61 ft-lb)

Universal joint ASSY to pinion shaft:

21 — 26 N•m (2.1 — 2.7 kg-m, 15 — 20 ft-lb)

Crossmember to body:

83 — 113 N•m (8.5 — 11.5 kg-m, 61 — 83 ft-lb)

c. Purge air from system on power steering models.

7. Rear Trailing Link Assembly

A: REMOVAL

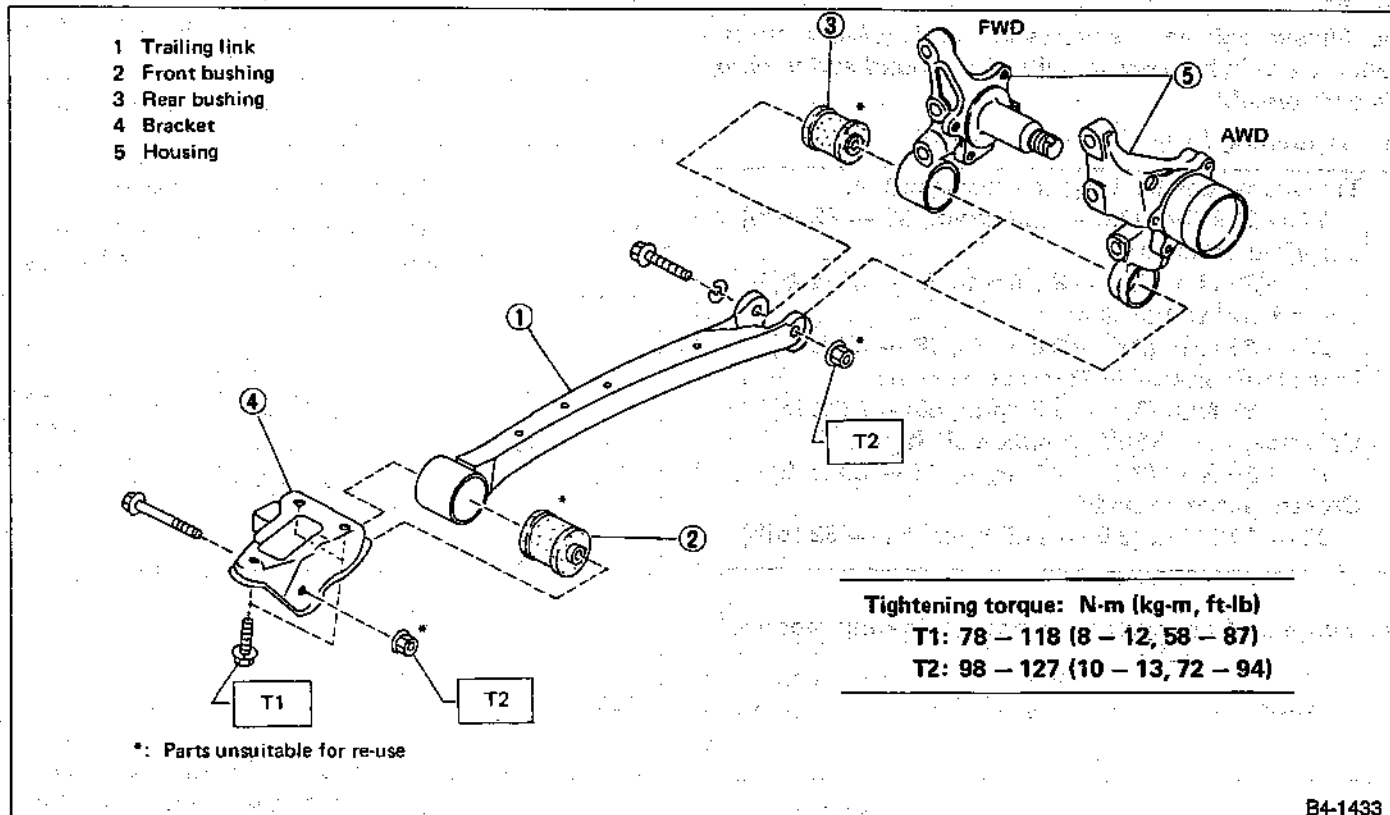


Fig. 69

- 1) Loosen rear wheel nuts.
- 2) Jack up vehicle, support it with safety stands (rigid racks) and remove rear wheels.
- 3) Remove both rear parking brake clamp and ABS sensor. (only vehicle equipped with ABS)
- 4) Remove bolts which secure trailing link ASSY to body.

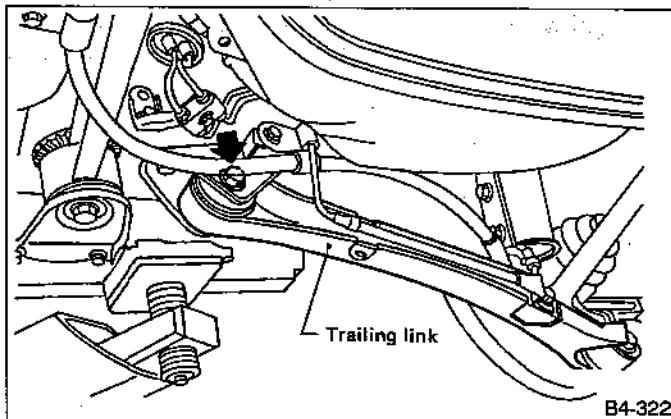


Fig. 70

- 5) Remove bolts which secure trailing link ASSY to rear housing.

B: DISASSEMBLY

1. FRONT BUSH

Using an INSTALLER & REMOVER SET (927720000), press front bushing out of place.

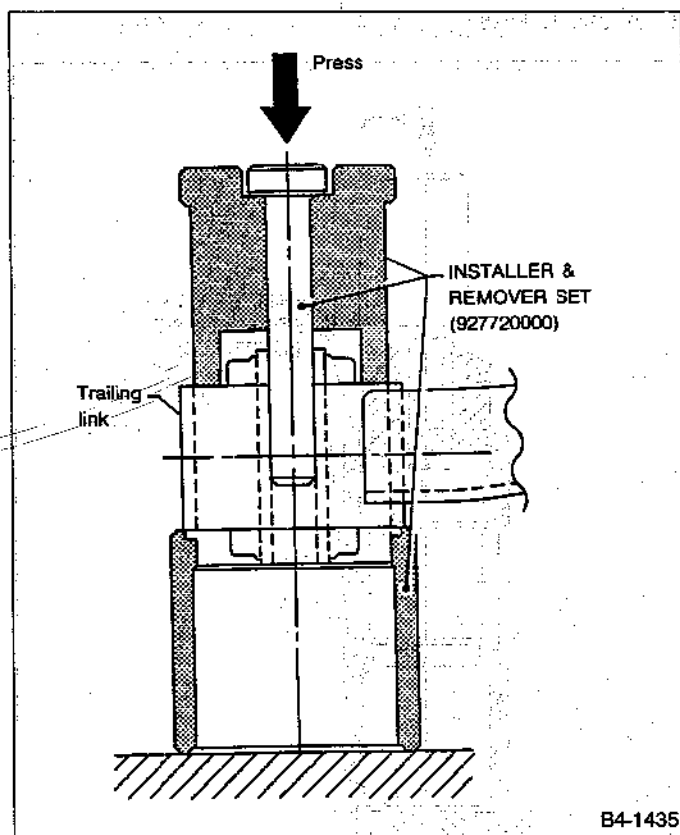


Fig. 71

2. REAR BUSH

- 1) Remove housing. Refer to "4-2. WHEELS AND AXLES" for removal procedures.
- 2) Using an INSTALLER & REMOVER SET (927730000), press rear bushing out of place.

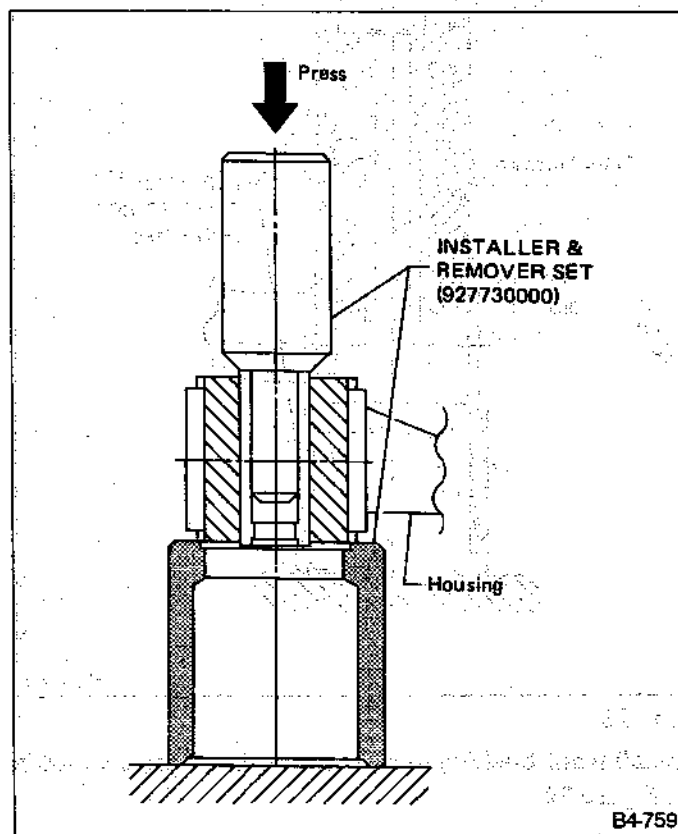


Fig. 72

C: INSPECTION

Check trailing links for bends, corrosion or damage.

D: ASSEMBLY

To assemble, reverse above disassembly procedures. Discard old bushings and replace with new ones.

1. FRONT BUSH

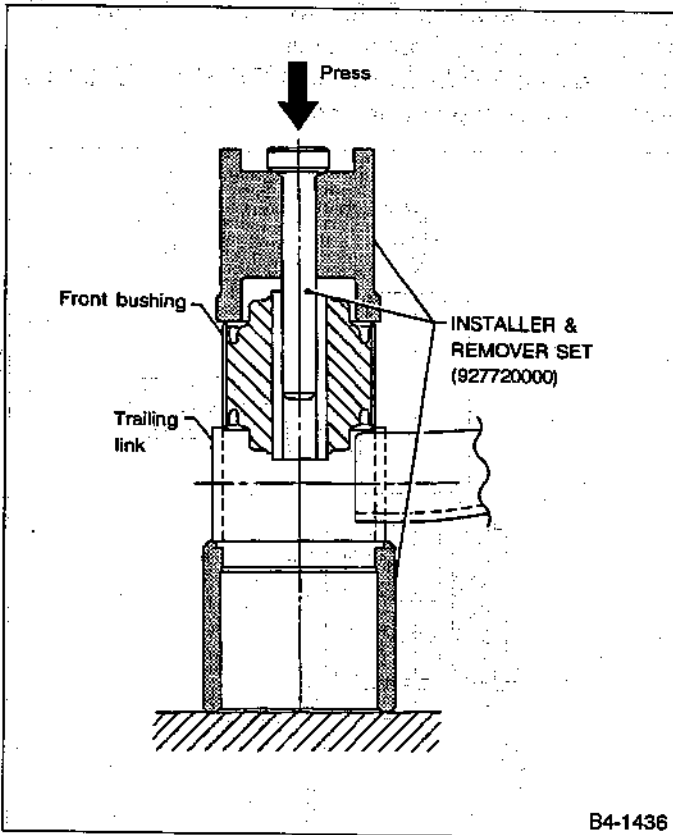


Fig. 73

Install front bushing in the proper direction, as shown in Figure 74.

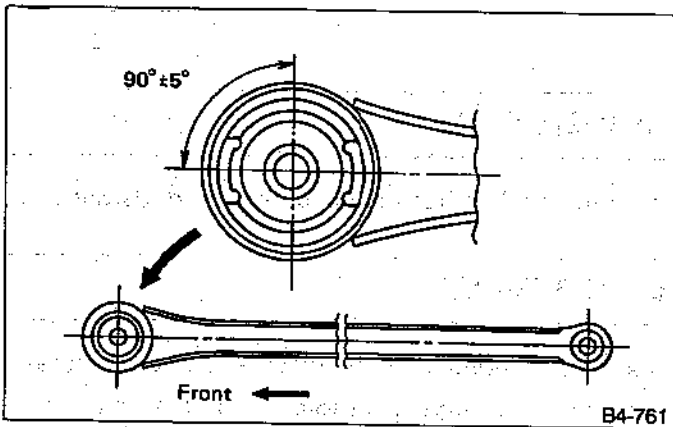


Fig. 74

2. REAR BUSH

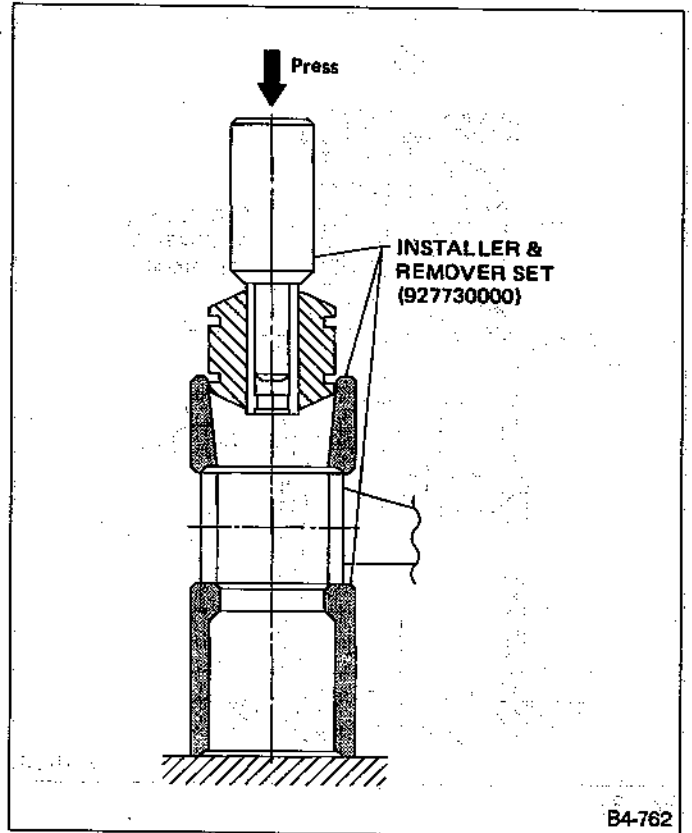


Fig. 75

E: INSTALLATION

Installation is in the reverse order of removal.

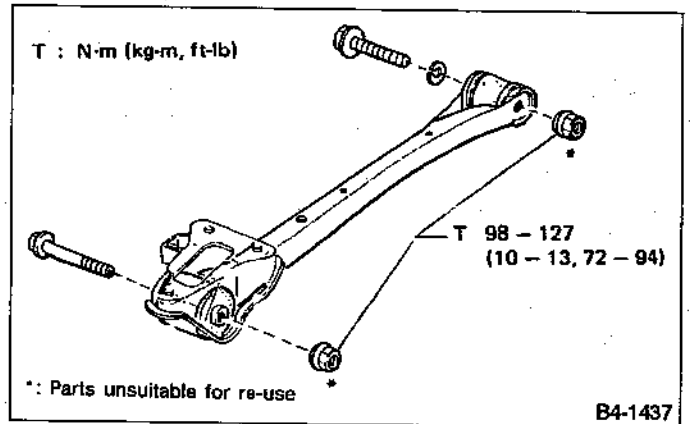


Fig. 76

Always tighten rubber bushing location when vehicle is empty.

8. Lateral Link Assembly

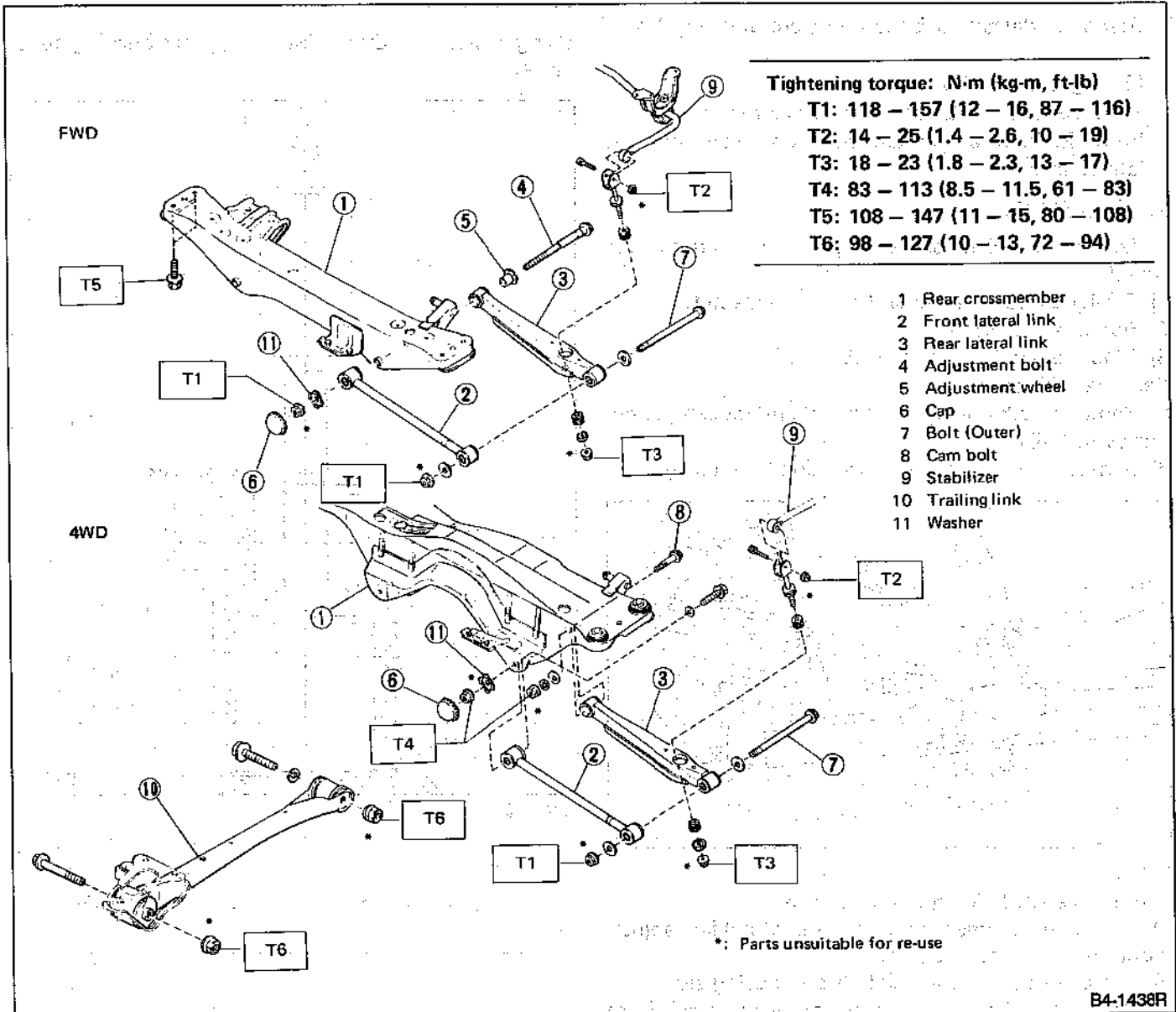


Fig. 77

A: REMOVAL

1. FWD MODEL

- 1) Remove rear exhaust pipe and muffler.
- 2) Remove stabilizer from rear lateral link.
- 3) Scribe an alignment mark on adjustment bolt, adjustment wheel and crossmember.
- 4) Remove outer lateral link bolt from housing.
- 5) Turn cap until it contacts stopper, then remove cap.
- 6) While holding adjustment bolt head with a wrench, loosen self-locking nut.

Always loosen self-locking nut when loosening adjustment bolt.

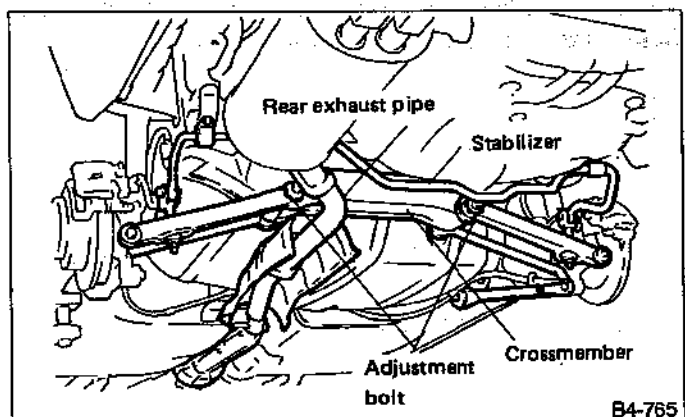


Fig. 78

7) Lateral link removal

(1) Left lateral links

Remove adjustment bolts and front and rear lateral links.

(2) Right lateral links

Remove two bolts securing crossmember to car body. Remove adjustment bolts and front and rear lateral links.

2. 4WD MODEL

1) Loosen wheel nuts. Jack up vehicle and remove wheel.

2) Straighten lock plates and remove axle nuts.

3) Remove stabilizers.

4) (Models equipped with ABS)

Remove ABS sensor.

5) Remove both trailing link bracket and loosen (do not remove!) trailing link bolts.

6) Remove bolts securing trailing link to housing.

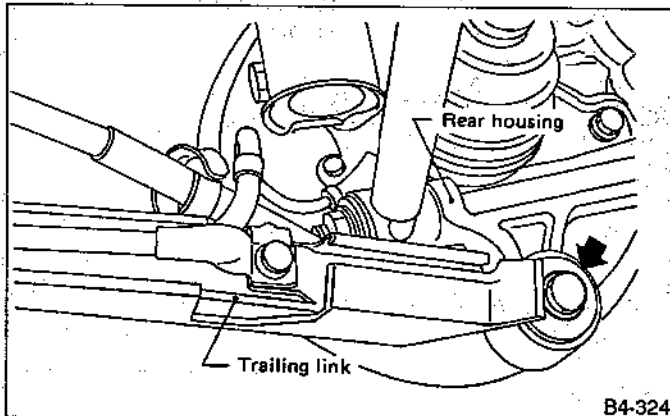


Fig. 79

7) Remove DOJ pin and detach shaft.

8) Scribe an alignment mark on rear lateral link adjustment bolt and crossmember.

9) Remove outer lateral link bolt on housing side.

10) Remove bolts securing front and rear lateral links to crossmember, detach lateral links.

To loosen adjustment bolt, always loosen nut while holding the head of adjustment bolt.

B: DISASSEMBLY

Using an INSTALLER & REMOVER, press bushing out of place.

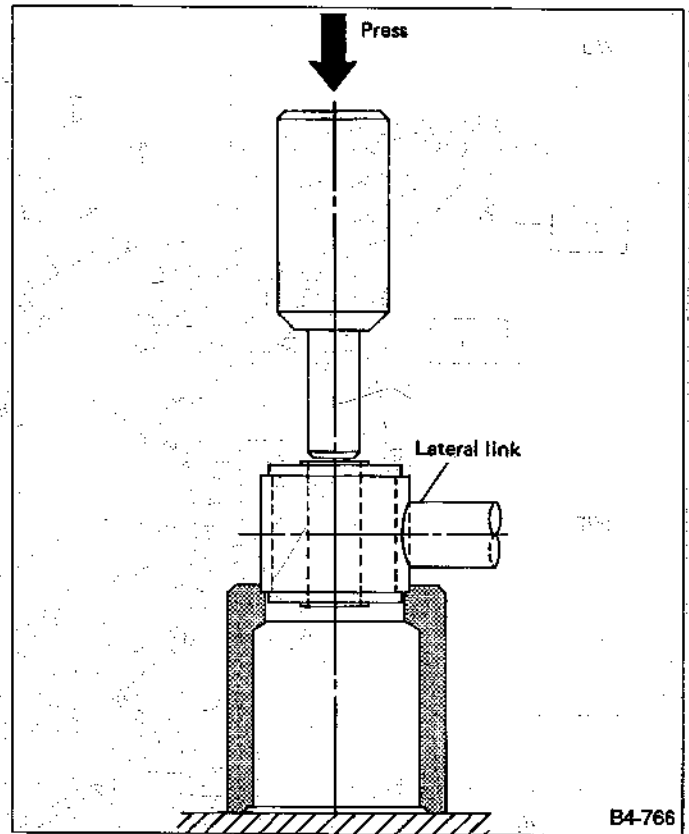


Fig. 80

a. Using the following figure as a guide, verify the type of bushings.

b. Select **INSTALLER & REMOVER** according to the type of bushings used.

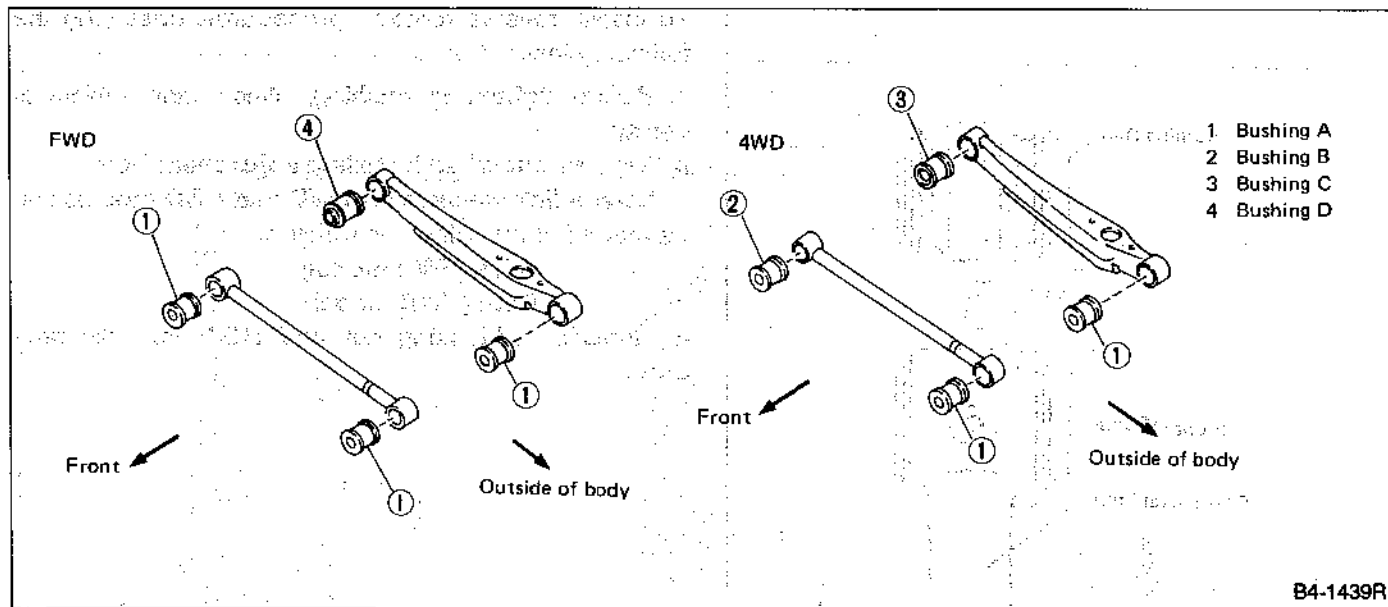


Fig. 81

Bushing	INSTALLER & REMOVER SET
Bushing A	927700000
Bushing B	927690000
Bushing C	927700000
Bushing D	927710000

C: INSPECTION

Visually check lateral links for damage or bends.

D: ASSEMBLY

Using an **INSTALLER & REMOVER**, press bushing into place.

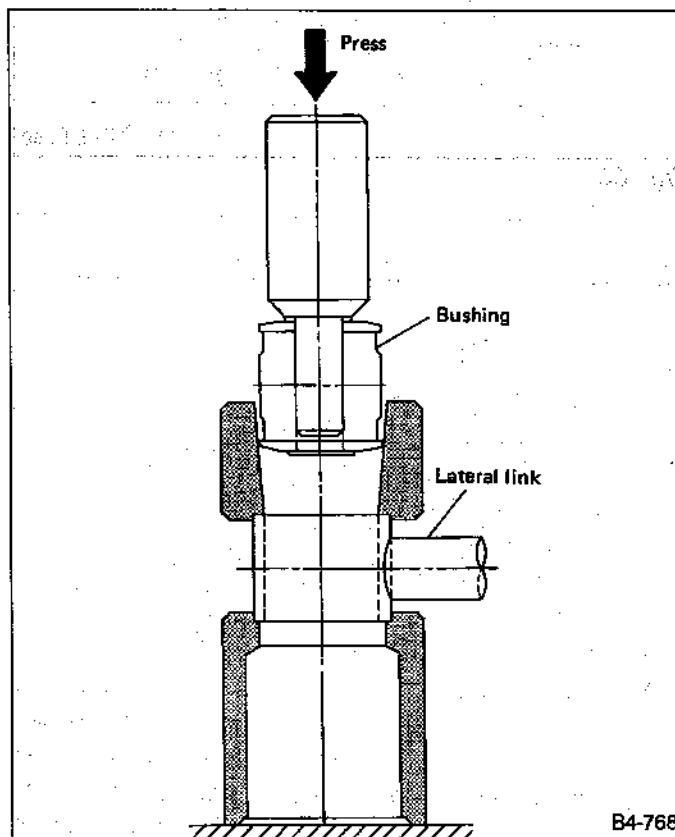


Fig. 82

a. Discard old bushing and replace with a new one.

b. Pay attention to the direction of bushing "D" as shown in figure 83.

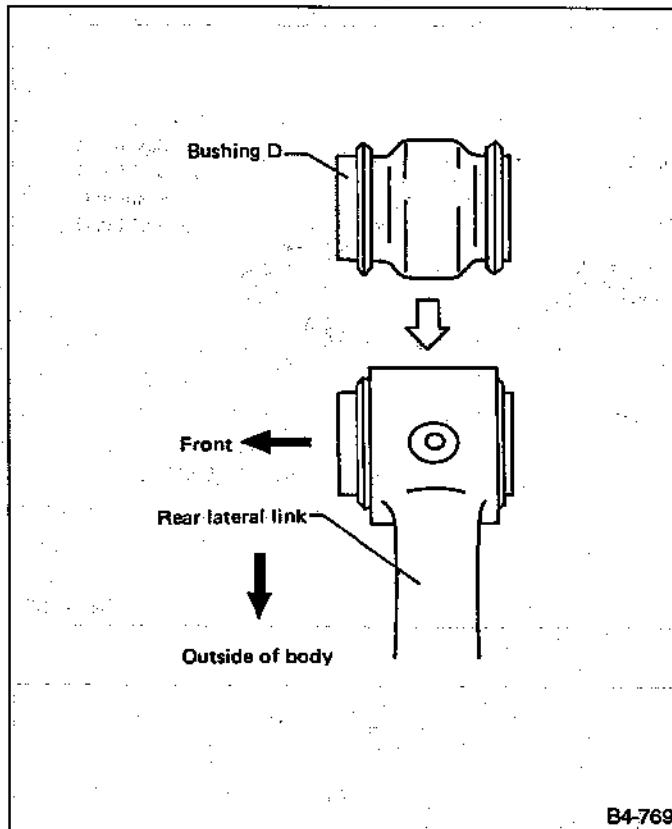


Fig. 83

E: INSTALLATION

To install, reverse removal procedures, observing the following instructions.

- a. Before tightening bushing, check that vehicle is empty.
- b. Tighten nut when installing adjustment bolt.
- c. Lateral link washers for FWD and 4WD models can be identified by colors, as follows:
 - Olive (FWD model)
 - Gold (4WD model)
- d. Replace self-locking nut and DOJ pin with new ones.

9. Rear Strut Assembly

A: REMOVAL

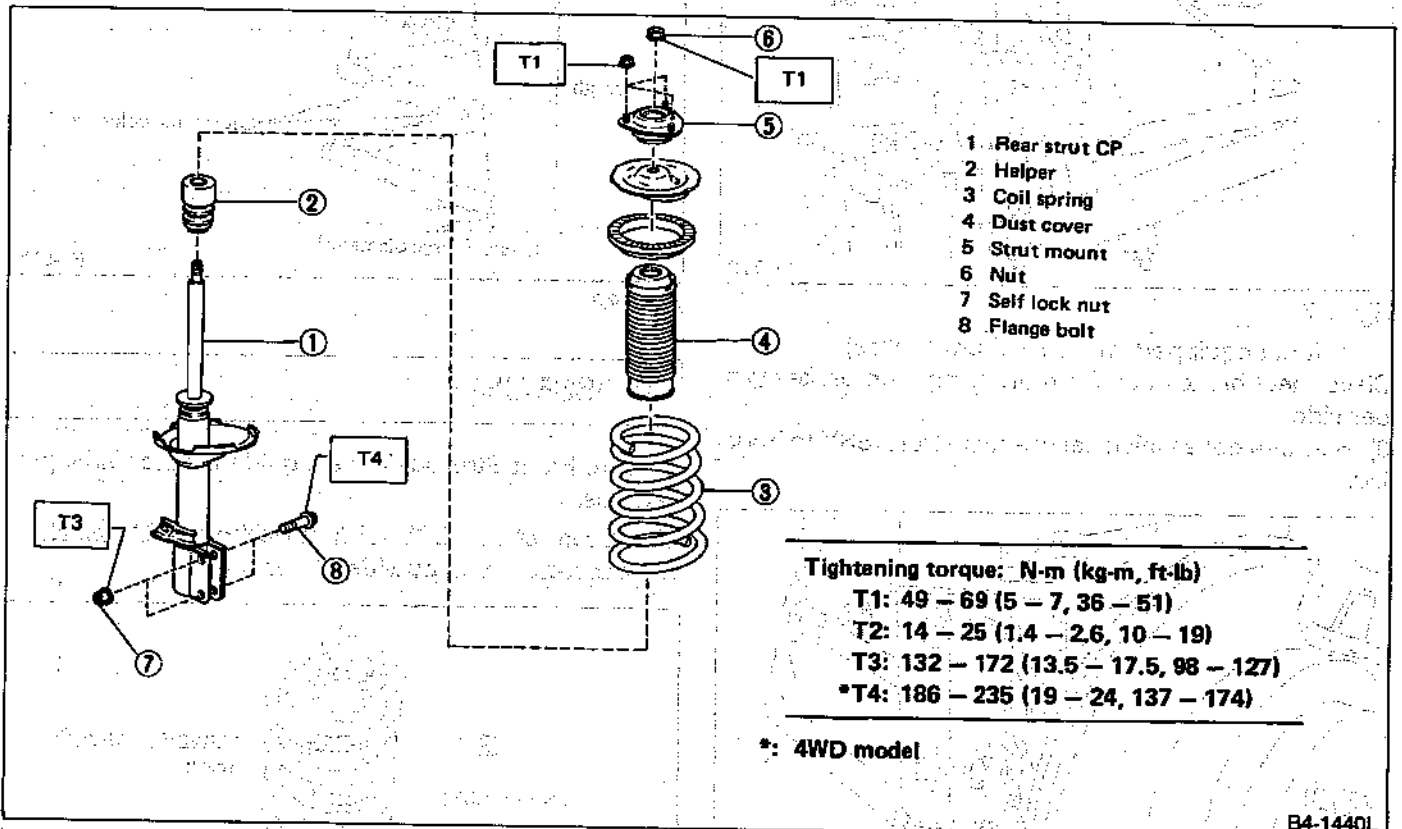


Fig. 84

- 1) Disconnect ground cable from battery.
- 2) Depress brake pedal and secure it in that position using a wooden block, etc.
- 3) (Sedan)
Remove rear seat cushion and backrest.

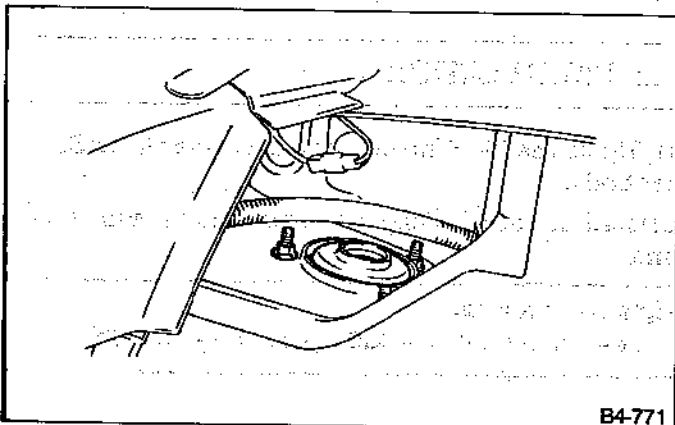


Fig. 85 Sedan

(Wagon)

Remove rear speaker grille.

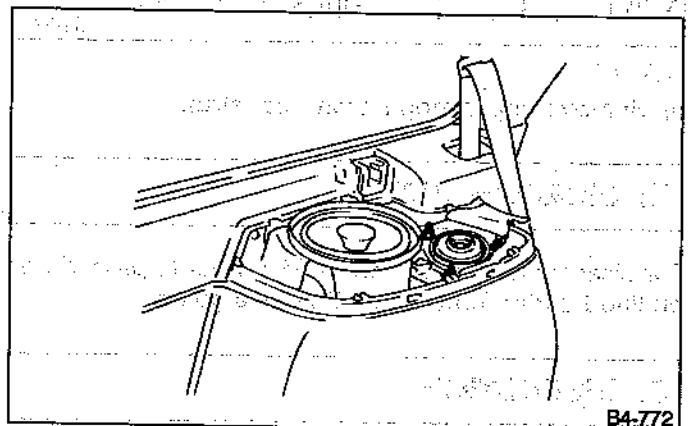


Fig. 86 Wagon

- 4) Loosen rear wheel nuts.
- 5) Jack up vehicle, support it with safety stands (rigid racks) and remove rear wheels.
- 6) Remove brake hose clip.
- 7) (Model equipped with rear disc brakes)
Remove union bolt from brake caliper.

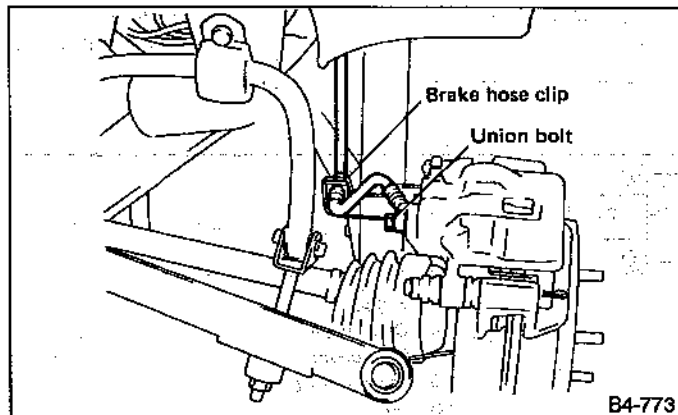


Fig. 87

(Model equipped with rear drum brakes)
Disconnect brake hose from brake pipe on brake cylinder side.

8) Remove bolts which secure rear strut ASSY to housing.

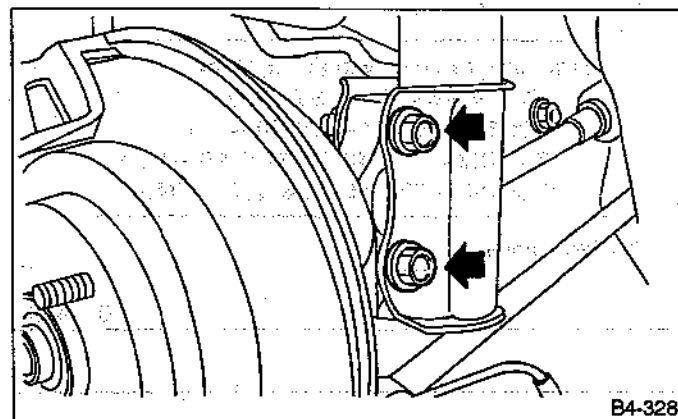


Fig. 88

9) Remove upper mount from rear strut.

B: DISASSEMBLY

For disassembly of rear strut ASSY, refer to procedures outlined under front strut ASSY as a guide.

C: INSPECTION

Refer to Front Strut ASSY as a guide for inspection procedures.

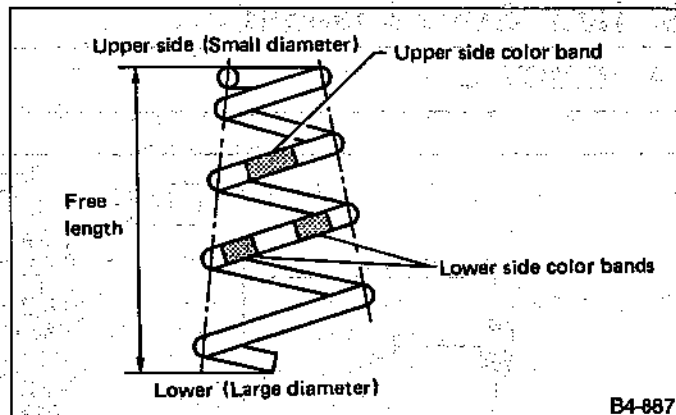


Fig. 89

D: ASSEMBLY

Refer to Front Strut ASSY as a guide for assembly procedures.

Install rear strut ASSY with "FWD" or "4WD" mark on strut mount facing outside of car body.

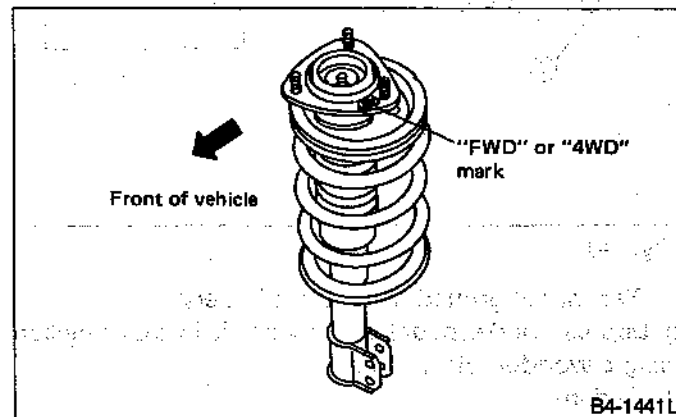


Fig. 90

E: INSTALLATION

1) Tighten self-locking nut used to secure strut ASSY to car body.

Discard old self-locking nut, and replace with a new one.

Tightening torque:

14 — 25 N·m (1.4 — 2.6 kg-m, 10 — 19 ft-lb)

2) Tighten bolts which secure rear strut ASSY to housing.

Tightening torque:

132 — 172 N·m (13.5 — 17.5 kg-m, 98 — 127 ft-lb)

Discard old self-locking nut, and replace with a new one.

3) (Model with rear disc brake)

Tighten brake hose union bolt on brake caliper.

Tightening torque:

15 — 21 N·m (1.5 — 2.1 kg-m, 11 — 15 ft-lb)

(Model with rear drum brakes)

Connect brake hose to brake pipe.

Tightening torque:

13 — 18 N·m (1.3 — 1.8 kg-m, 9 — 13 ft-lb)

4) Insert hose clip between brake hose and lower side of strut ASSY.

- a. Check that hose clip is positioned properly.
- b. Check brake hose for twisting, or excessive tension.
- c. (Model equipped with ABS)

Do not subject ABS sensor harness to excessive tension.

- d. Be sure to bleed air from brake system.

5) Lower vehicle and tighten wheel nut.

Tightening torque:

78 — 98 N·m (8 — 10 kg-m, 58 — 72 ft-lb)

6) (Sedan)

Install rear seat backrest and rear seat cushion.

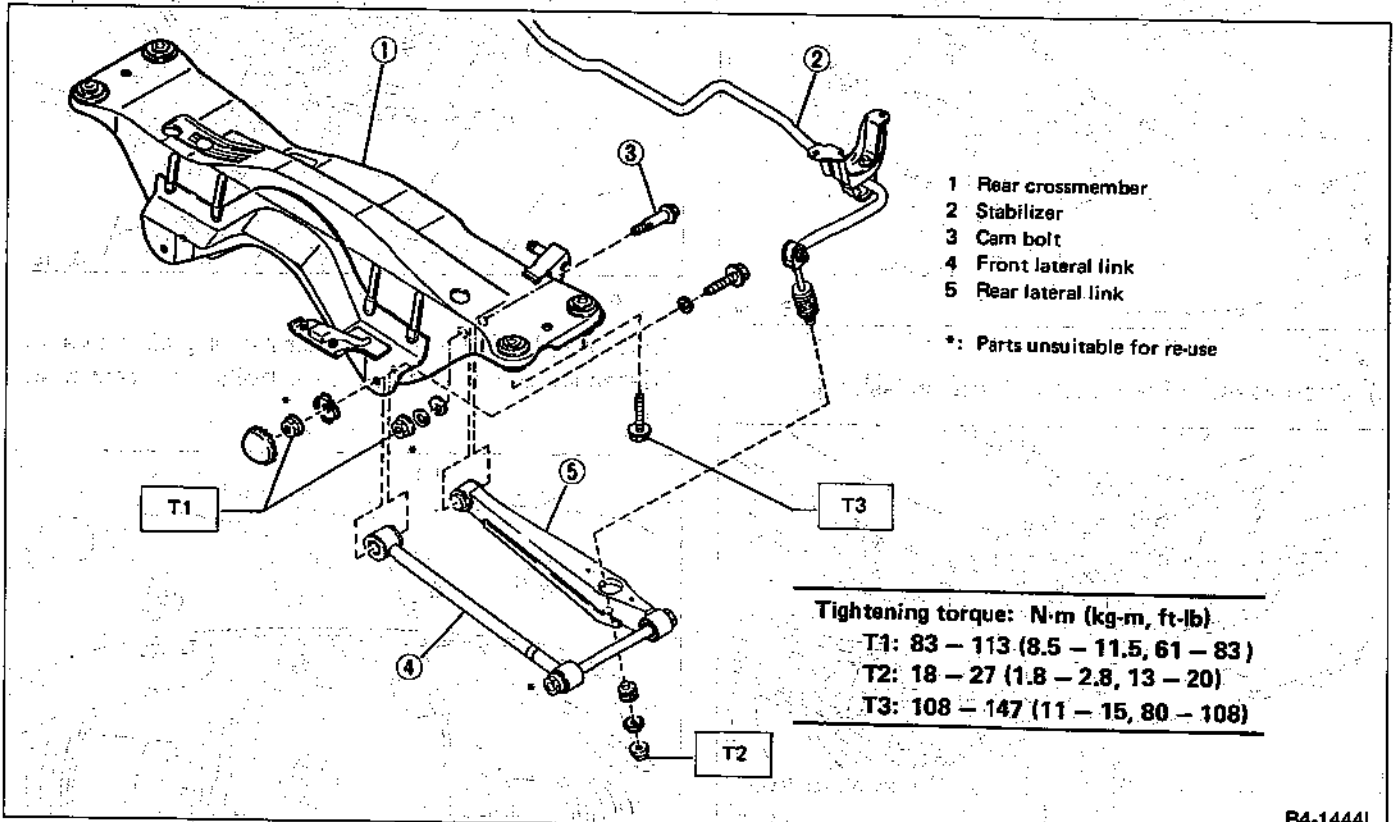
(Wagon)

Install rear speaker grille.

7) Connect ground cable with negative terminal of battery.

11. Rear Crossmember (4WD)

A: REMOVAL



B4-1444L

Fig. 93

Do not subject ABS sensor harness to excessive tension (if equipped).

- 1) Separate front exhaust pipe and rear exhaust pipe.
- 2) Remove rear exhaust pipe and muffler.
- 3) Remove front cover of rear differential mount.

- 4) Remove propeller shaft.
- 5) Remove heat-shielding cover.
- 6) Remove rear stabilizer (if so equipped).
- 7) Remove clamps and bracket of parking brake cable.

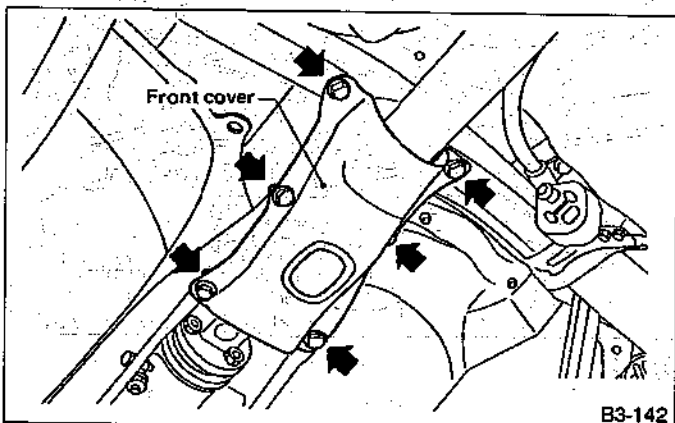


Fig. 94

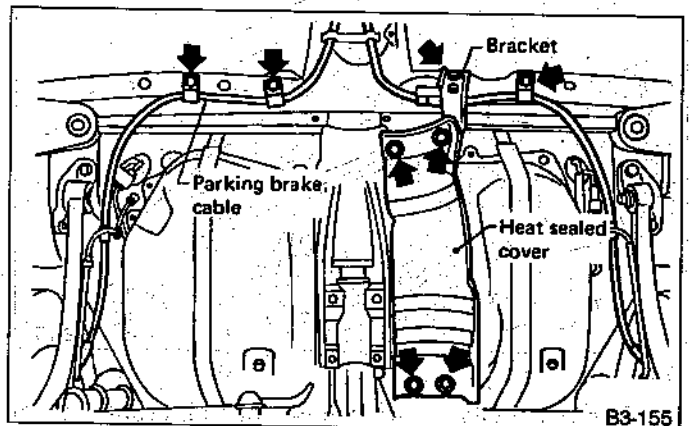
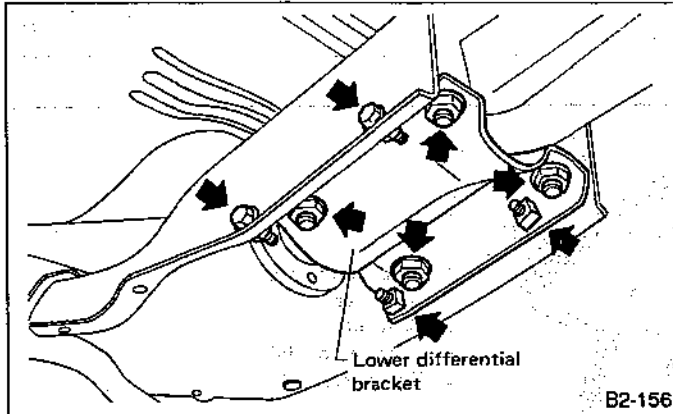


Fig. 95

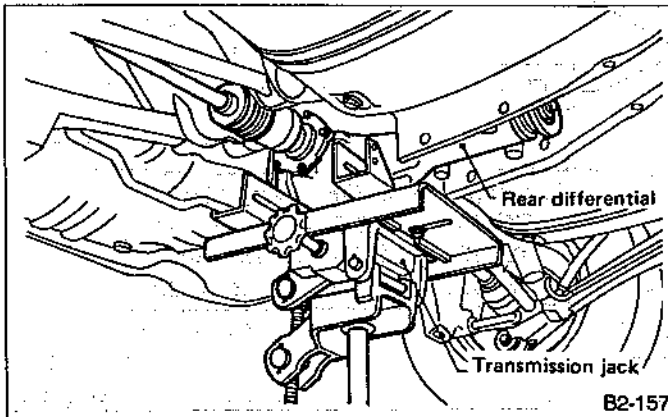
8) Remove lower differential bracket.



B2-156

Fig. 96

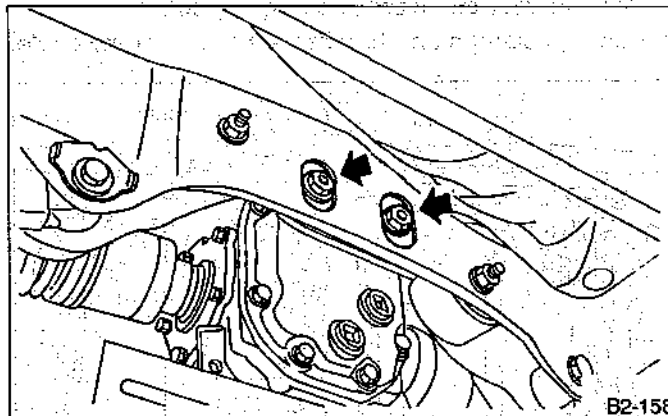
9) Support rear differential with transmission jack.



B2-157

Fig. 97

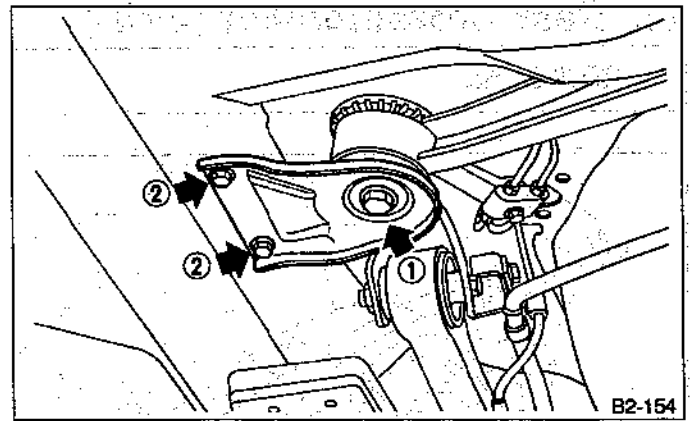
10) Remove self-locking nuts connecting rear differential to rear member.



B2-158

Fig. 98

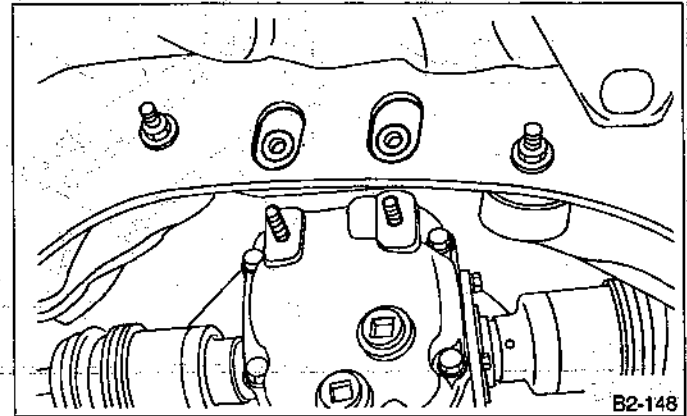
11) Remove bolts which secure rear differential front member to body. Loosen bolt ① first, then remove bolts ②.



B2-154

Fig. 99

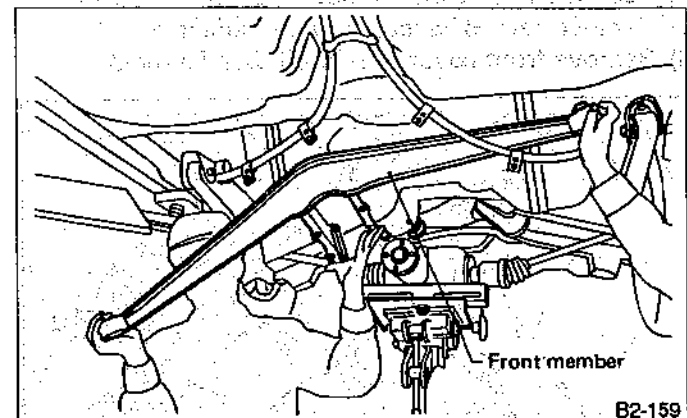
12) While slowly lowering transmission jack, move rear differential forward and remove bolts from rear member.



B2-148

Fig. 100

13) Remove front member from body.



B2-159

Fig. 101

14) Remove rear drive shaft from rear differential and suspend it in air.

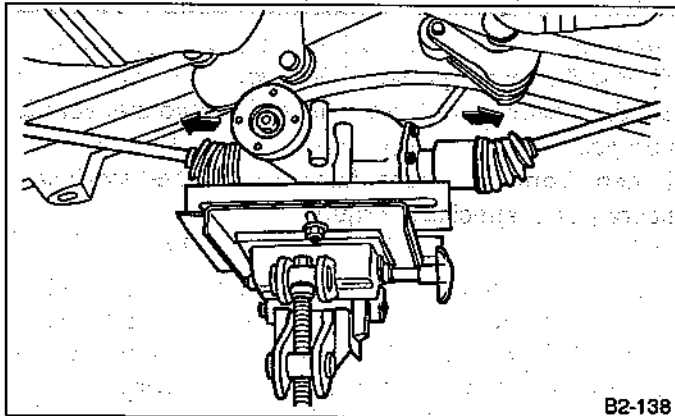


Fig. 102

15) Remove rear differential member from crossmember.

16) Scribe an alignment mark on rear lateral link cam bolt and crossmember.

17) Remove front and rear lateral links by loosening nuts.

Loosen nut to remove lateral link.

18) Remove bolts securing crossmember to car body, and remove crossmember.

B: INSPECTION

Check removed parts for wear, damage and cracks, and correct or replace if defective.

C: INSTALLATION

1) Install rear crossmember to body.

Tightening torque:

108 — 147 N·m (11 — 15 kg-m, 80 — 108 ft-lb)

2) Temporarily install front and rear lateral links on crossmember.

3) Install rear differential member on crossmember.

4) Temporarily install rear differential, front member and lower differential bracket.

5) Using a transmission jack, raise rear differential. Connect drive shaft to rear differential.

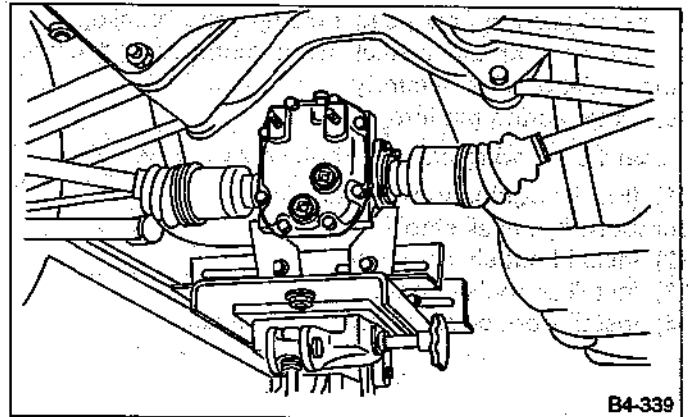


Fig. 103

6) Install rear differential on rear differential member.

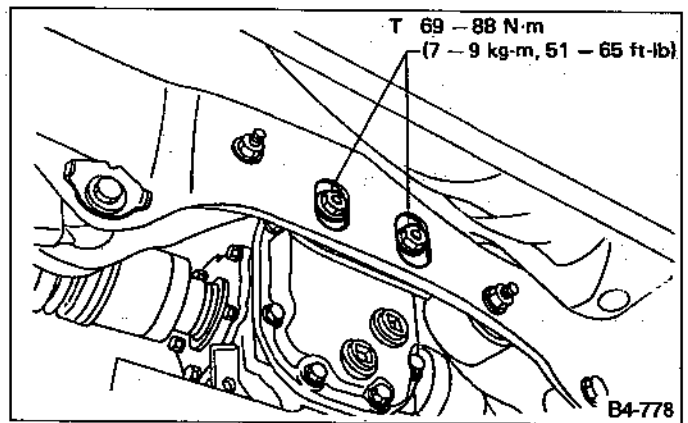


Fig. 104

7) Tighten front member bolts as outlined below:

- (1) Temporarily tighten bolt ①.
- (2) Tighten bolt ②.
- (3) Tighten bolt ①.

Tightening torque:

Bolt ①:

88 — 108 N·m (9 — 11 kg-m, 65 — 80 ft-lb)

Bolt ②:

25 — 40 N·m (2.5 — 4.1 kg-m, 18 — 30 ft-lb)

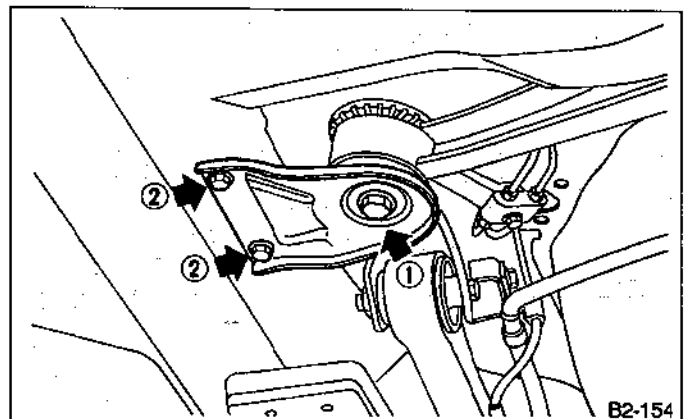


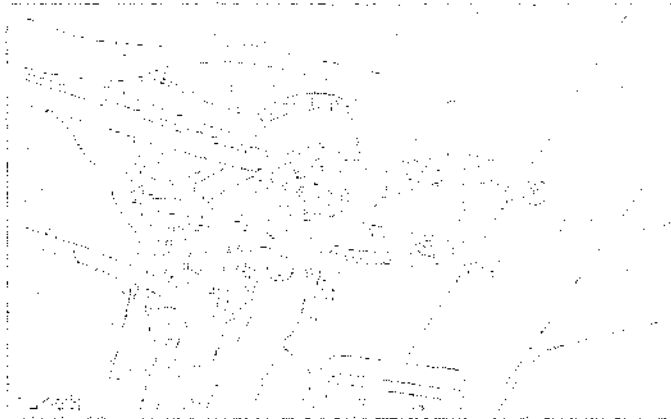
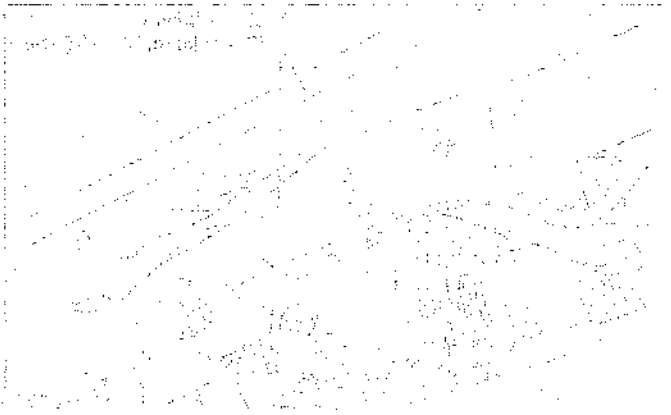
Fig. 105

- 8) Install parking brake cable clamps and bracket.
 - 9) Tighten rear differential, front member and lower differential bracket securely.
 - 10) Drive spring pin into DOJ.
- Discard old spring pin and replace with a new one.**
- 11) (Model equipped with stabilizer)
Temporarily install stabilizer.
 - 12) Install heat-shield cover.
 - 13) Install propeller shaft.
 - 14) Install front cover of rear differential.

Tightening torque:

59 — 78 N·m (6.0 — 8.0 kg-m, 43 — 58 ft-lb)

- 15) Install exhaust pipe and muffler.
 - 16) Lift down car body from lift and ensure that vehicle is empty.
- Tighten front and rear lateral links and stabilizer securely with specified torque.**



T TROUBLESHOOTING

1. Conventional Suspension

1. IMPROPER VEHICLE POSTURE OR IMPROPER WHEEL ARCH HEIGHT

Possible causes	Countermeasures
(1) Permanent distortion or breakage of coil spring	Replace.
(2) Unsmooth operation of damper strut	Replace.
(3) Installation of wrong transverse link	Replace with proper parts.
(4) Deformation of transverse link	Replace.

2. POOR RIDE COMFORT

1) Large rebound shock.

2) Rocking of vehicle continues too long after running over bump and/or hump.

3) Large shock in bumping.

Possible causes	Countermeasures
(1) Breakage of coil spring	Replace.
(2) Overinflation pressure of tire	Adjust.
(3) Improper wheel arch height	Adjust or replace coil springs with new ones.
(4) Fault in operation of damper strut	Replace.
(5) Damage or deformation of damper strut lower end bushing	Replace.
(6) Unsuitability of maximum and/or minimum length of damper strut	Replace with proper parts.
(7) Deformation or loss of bushing	Replace.
(8) Deformation or damage of helper ASSY	Replace.

3. NOISE

Possible causes	Countermeasures
(1) Wear or damage of damper strut component parts	Replace.
(2) Damage or deformation of damper strut lower end bushing	Replace.
(3) Loosening of transverse link installing bolt	Retighten to the specified torque.
(4) Deformation or loss of bushing	Replace.
(5) Loosening of lateral link installing bolt to crossmember bracket	Retighten to the specified torque.
(6) Unsuitability of maximum and/or minimum length of damper strut	Replace with proper parts.
(7) Breakage of coil spring	Replace.
(8) Loosening of each bolt and/or nut	Retighten to the specified torque.

SUBARU

1992

**SERVICE
MANUAL**

	Page
M MECHANISM AND FUNCTION	2
1. Front Axle	2
2. Rear Axle	4
3. Disc Wheel and Wheel Cap	6
S SPECIFICATIONS AND SERVICE DATA	7
C COMPONENT PARTS	10
1. Front Axle	10
2. Rear Axle (4WD)	11
W SERVICE PROCEDURE	13
1. Front Axle	13
2. Rear Axle (4WD)	19
3. Rear Axle (FWD)	25
4. Front and Rear Drive Shafts	28
5. Half Wheel Cap	33
6. Full Wheel Cap	34
7. Steel Wheel and Tire	34
8. Aluminum Wheel	35
9. Wheel Balancing	35
10. Installation of Wheel Assembly to Vehicle	35
11. Tire Rotation	36



M MECHANISM AND FUNCTION

1. Front Axle

A: GENERAL

The inboard end of the axle shaft is connected to the transmission via a constant velocity joint (Double Offset Joint: DOJ) which provides flexible capabilities in the longitudinal direction while the outboard end is supported by taper roller bearings located inside the housing via a under cut free joint (UFJ) which features a large operating angle.

Since the drive shaft employs constant velocity joints, it provides smooth, even rotation of the drive wheels without any vibration.

The bearing utilizes a preloaded, non-adjustable tapered roller unit design.

The hub is fitted to the tapered roller bearing inside the housing. The UFJ's spindle is "serration-fitted" to the hub and is clinched to it with axle nuts. After front axle parts have been repaired, toe-in should be adjusted.

The disc rotor is an external mounting type. It is secured together with the disc wheel using hub bolts to facilitate maintenance of the disc rotor.

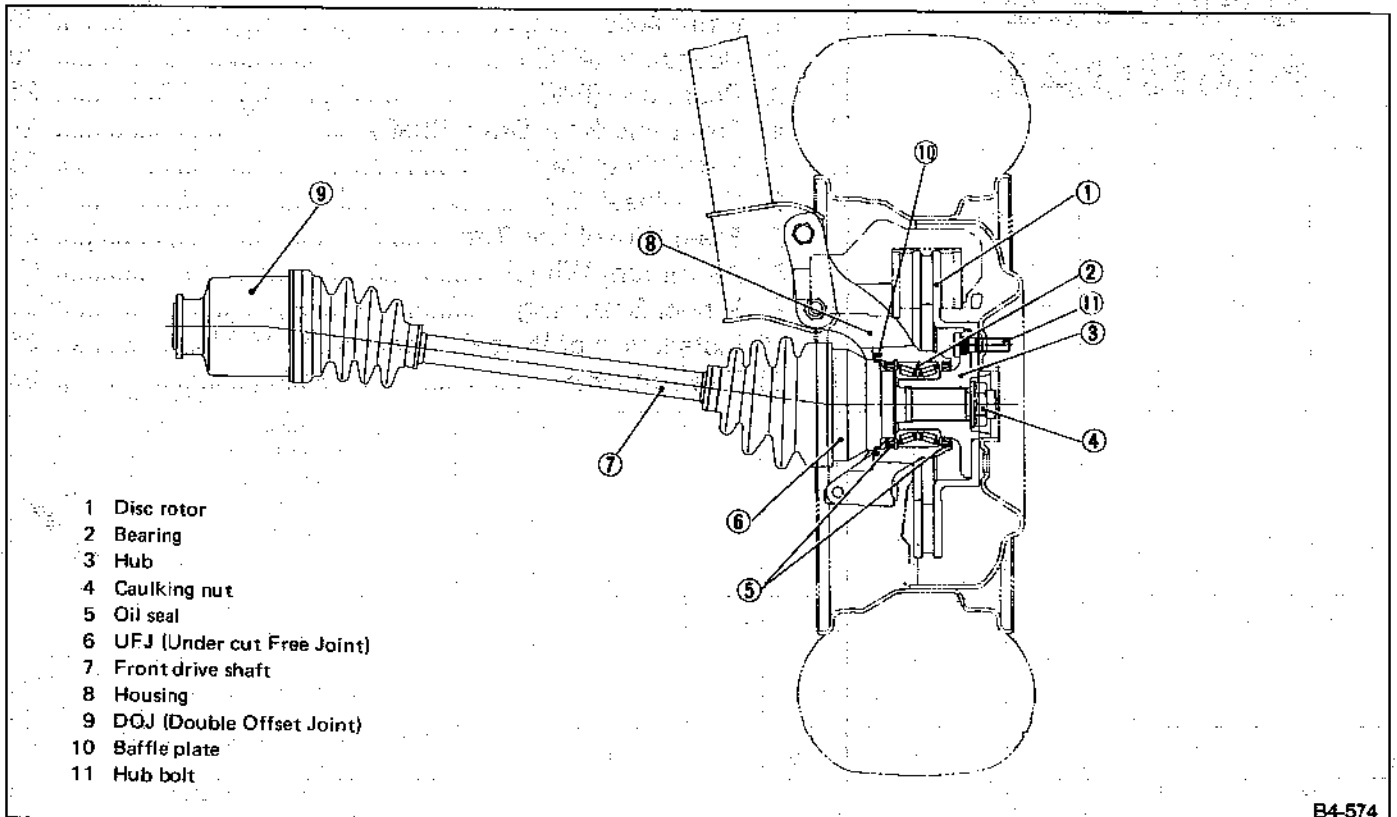


Fig. 1

B4-574

B: FRONT DRIVE SHAFT

The constant-velocity joint on the differential side is a double offset (DOJ) type which can be disassembled for

maintenance. It provides the maximum operating angle of 23° and can also be moved in the axial direction. The constant-velocity joint on the tire side is an extrawide, undercut-free type (UFJ) which provides a maximum operating angle of 50°.

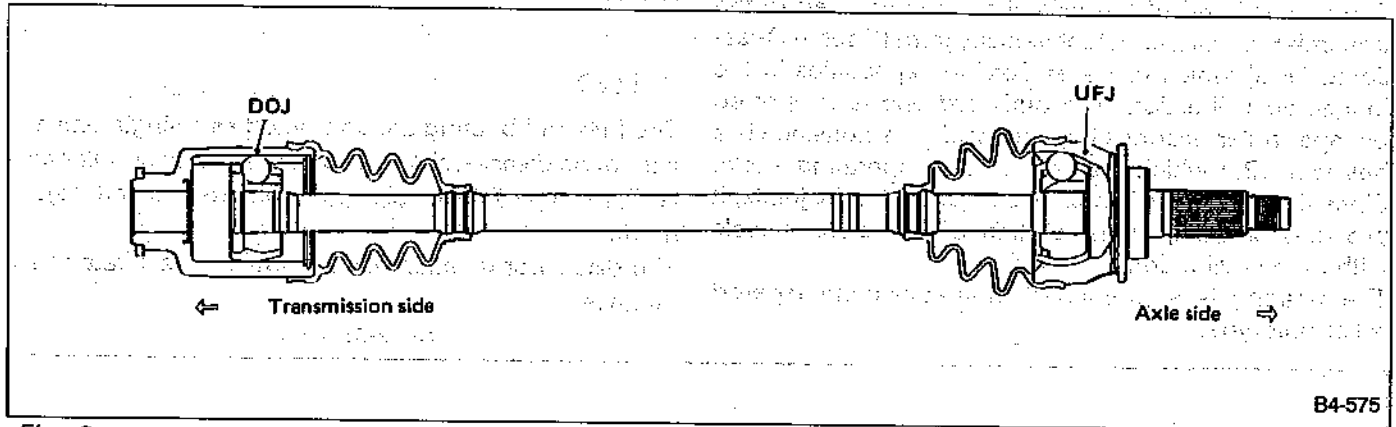


Fig. 2

1. CONSTRUCTION OF UNDERCUT-FREE JOINT (UFJ)

The component parts of the UFJ are the same as those used with the BJ; however, the only difference between the two occurs in the shape of the track where the torque transmission ball rolls. The BJ's track is an arc type (as from the cross-sectional contour) while the UFJ's track is a combination of a straight line and arc. When viewed from the axial center of the shaft, the UFJ has no undercut (shown by shaded area) portions so that its bending angle can be increased.

The UFJ has undergone modifications to increase the ball diameter and redesign the joint interior. Although its maximum bending angle is increased to 50° (rather than 46.5° for the BJ), the UFJ is at least as strong and durable as the BJ.

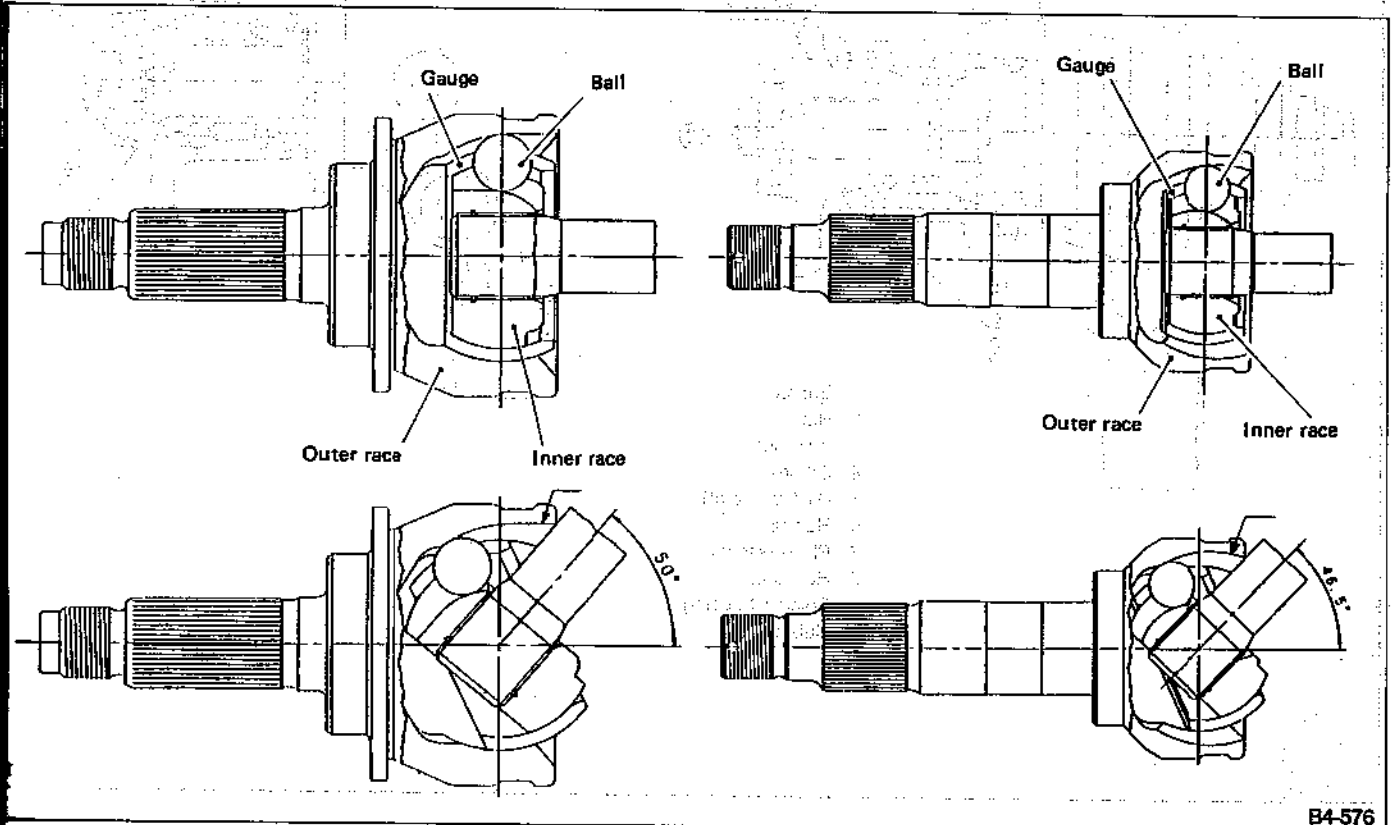


Fig. 3

B4-576

2. Rear Axle

A: GENERAL

1. 4WD

The inboard end of the axle shaft is connected to the transmission via a constant velocity joint (Double Offset Joint: DOJ) which provides flexible capabilities in the longitudinal direction. The outboard end is supported by taper roller bearings located inside the housing via a bell joint (BJ) which features a large operating angle. Since the drive shaft employs constant velocity joints, it provides smooth, even rotation of the drive wheels without any vibration.

The bearing is a preloaded, non-adjustable tapered roller unit type.

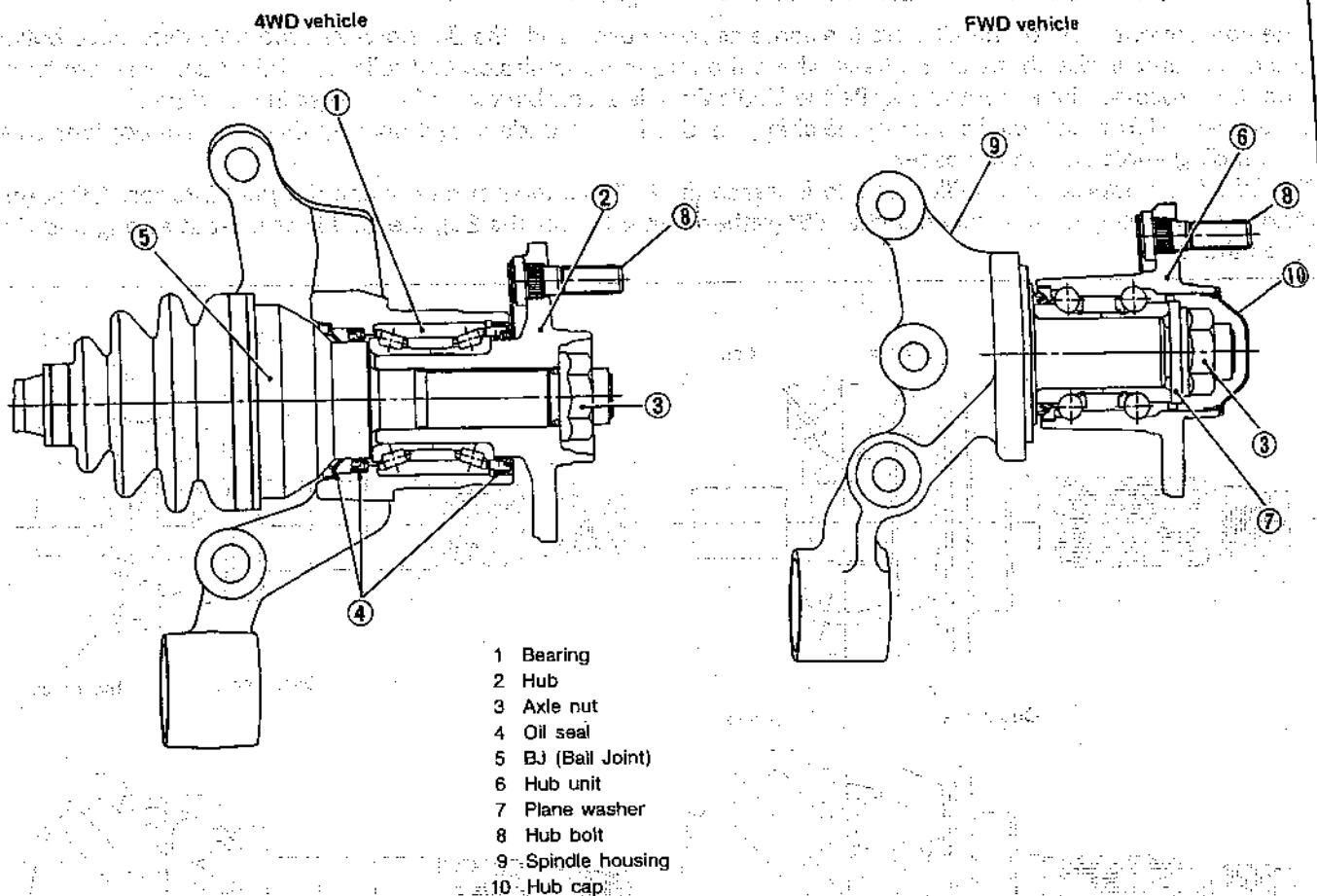
The hub is fitted to the tapered roller bearing inside the housing. The BJ's spindle is "serration-fitted" to the hub and is clinched to it with axle nuts.

The disc rotor is externally mounted to facilitate maintenance. Hub bolts and axle nuts are also used to secure the front axle.

2. FWD

The hub and bearing are combined as a single unit and cannot be disassembled. The bearing is an angular contact ball type which does not require preload adjustment.

The disc rotor is externally mounted to facilitate maintenance.



B4-577

Fig. 4

B: REAR DRIVE SHAFT

The constant-velocity joint on the differential side is a double offset type (DOJ) which can be disassembled for maintenance. It provides the maximum operating

angle of 23° and can be moved in the axial direction. The constant-velocity joint on the tire side is a bell-type (BJ) which provides a maximum operating angle of 46°.

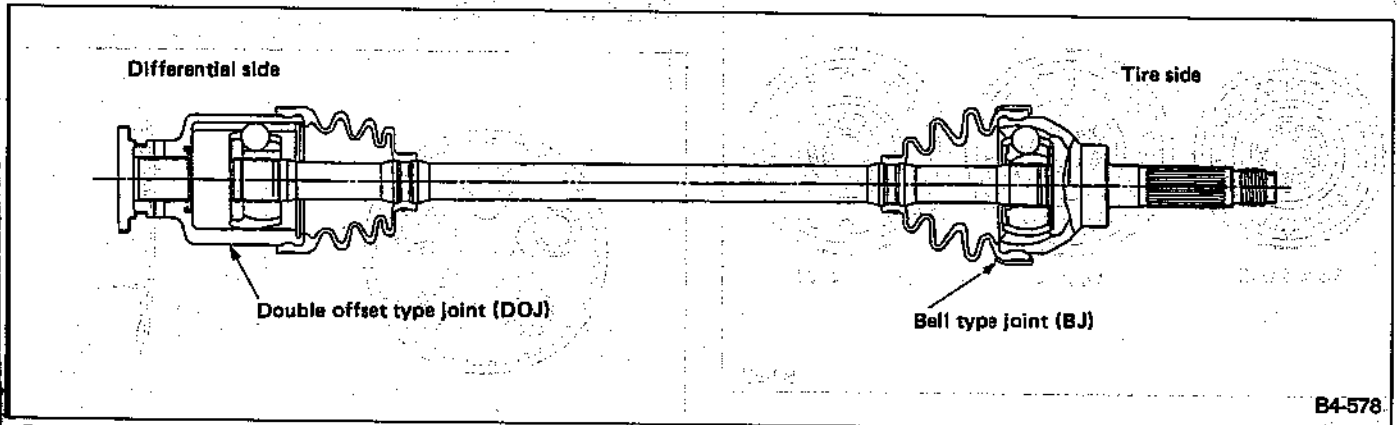


Fig. 5

3. Disc Wheel and Wheel Cap

A: GENERAL

1. DISC WHEEL (Steel)

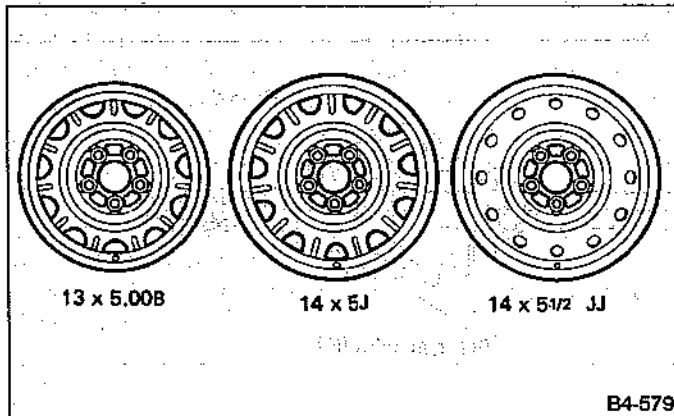


Fig. 6

2. ALUMINUM ALLOY WHEEL

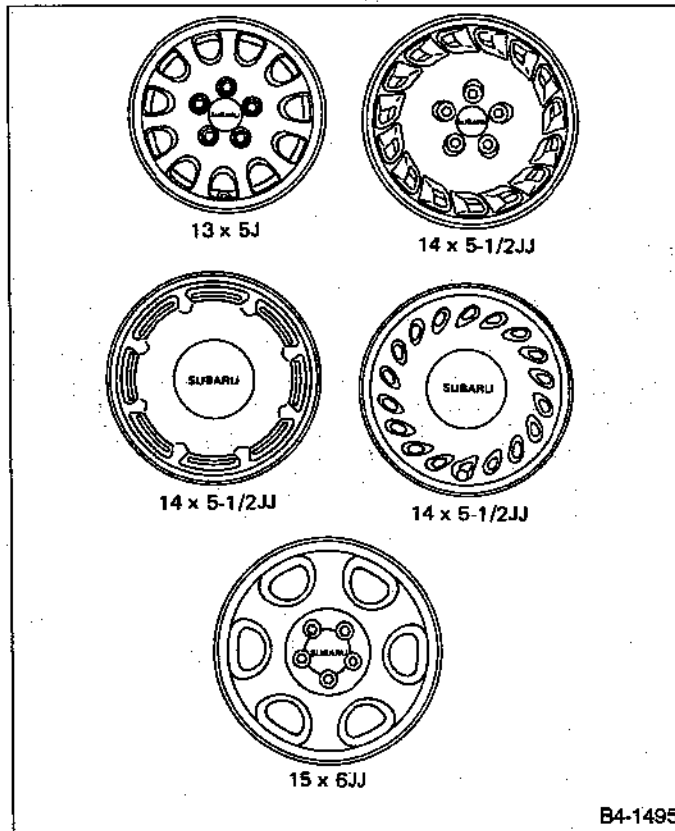


Fig. 7

3. HALF CAP

The half cap is engaged by snapping its eight pawls into the grooves on the flange located in the center of the steel wheel.

The half cap can be installed by pushing it on with both hands and removed by prying it off with a lever (furnished with tool kit).

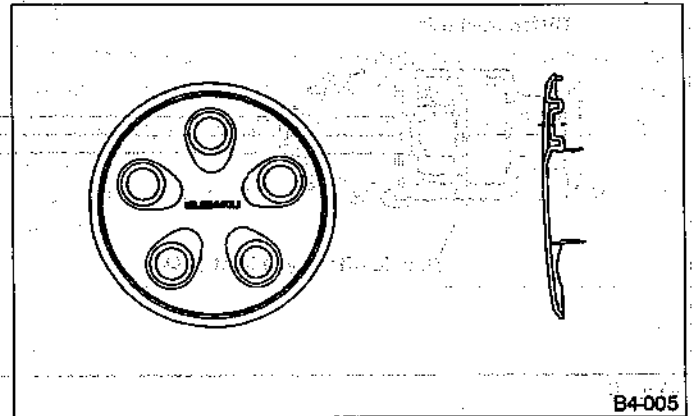


Fig. 8

4. FULL WHEEL CAP

The full wheel cap is engaged with the rim by means of its eight wire-spring legs. It can be installed by pushing it on with both hands and removed by prying it off with a lever (furnished with tool kit).

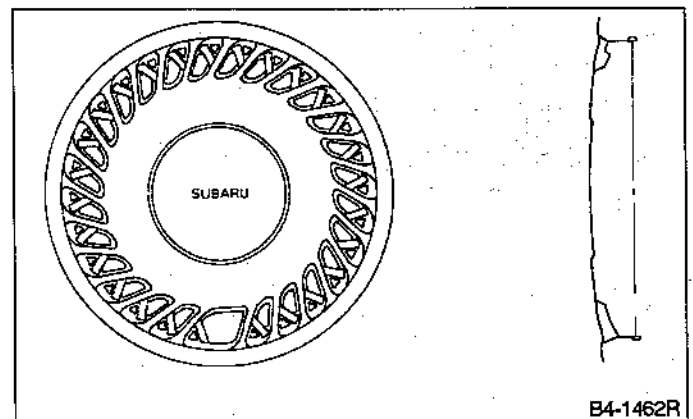


Fig. 9

S SPECIFICATIONS AND SERVICE DATA

A: SPECIFICATIONS

1. TIRE & WHEEL SIZE

Front and Rear				Spare
Tire size	Rim size	Rim offset mm (in)	PCD mm (in)	
165SR13 165HR13 165R13 82S 165R13 82S	13 x 5.00B 13 x 5J	50 (1.97)	100 (3.94) dia.	Same as front and rear tires and rims
175/70R14 84S 175/70R14 84T 175/70R14 84H	14 x 5J 14 x 5 1/2JJ	55 (2.17)	100 (3.94) dia.	
185/70R14 87H 185/70R14 88H	14 x 5J 14 x 5 1/2JJ	55 (2.17)	100 (3.94) dia.	
205/60R15 91V	15 x 6JJ	55 (2.17)	100 (3.94) dia.	

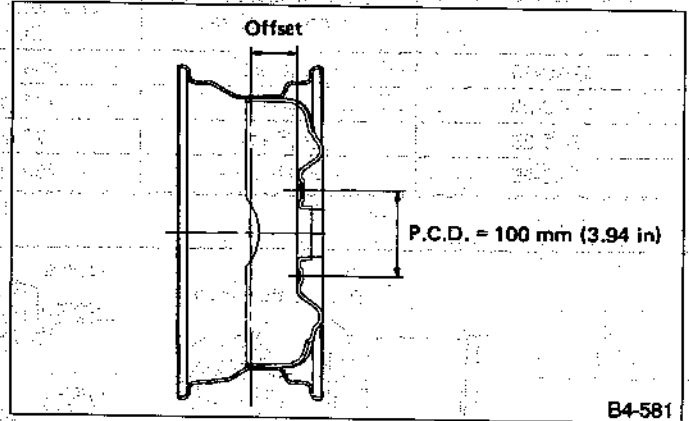


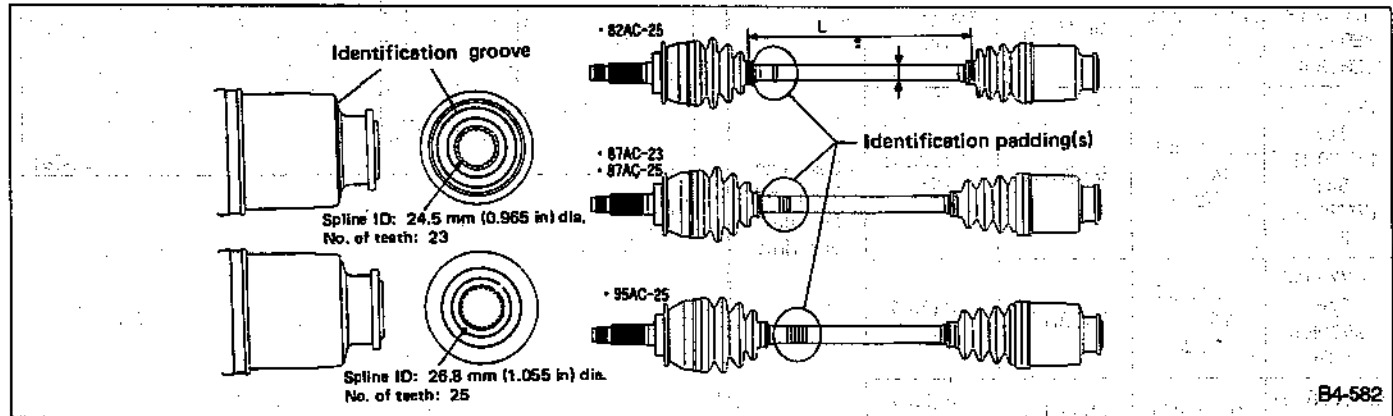
Fig. 10

2. TIRE INFLATION PRESSURE

Model	Tire size	Tire inflation pressure kPa (kg/cm ² , psi)	
		Light load	Full load
4-door Sedan Station Wagon	165SR13 165HR13 165R13 82S 165R13 82T	Ft: 210 (2.1, 30) Rr: 200 (2.0, 29)	Ft: 230 (2.3, 33) Rr: 230 (2.3, 33)
	175/70R14 84S 175/70R14 84T 175/70R14 84H	Ft: 210 (2.1, 30) Rr: 200 (2.0, 29)	Ft: 240 (2.4, 35) Rr: 250 (2.5, 36)
	185/70R14 87H 185/70R14 88H	Ft: 210 (2.1, 30) Rr: 200 (2.0, 29)	
4-door Sedan Turbo	205/60R15 91V	Ft: 210 (2.1, 30) Rr: 200 (2.0, 29)	
Touring Wagon	185/70R14 87H 185/70R14 88H	Ft: 210 (2.1, 30) Rr: 200 (2.0, 29)	Ft: 210 (2.1, 30) Rr: 230 (2.3, 33)
Touring Wagon Turbo	205/60R15 91V	Ft: 210 (2.1, 30) Rr: 200 (2.0, 29)	Ft: 210 (2.1, 30) Rr: 220 (2.2, 31)

3. FRONT DRIVE SHAFT ASSEMBLY

Type of axle shaft ASSY	SHAFT			DOJ
	No. of identification paddings on shaft	Distance between inner and outer boots (L) mm (in)	Diameter (D) mm (in)	No. of spline teeth
82AC-25	1 (One)	308 (12.13)	21.5 (0.846)	25
87AC-23	2 (Two)	277 (10.91)	22.5 (0.886)	23
87AC-25	2 (Two)	277 (10.91)	22.5 (0.886)	25
95AC-25	3 (Three)	260 (10.24)	24 (0.94)	25

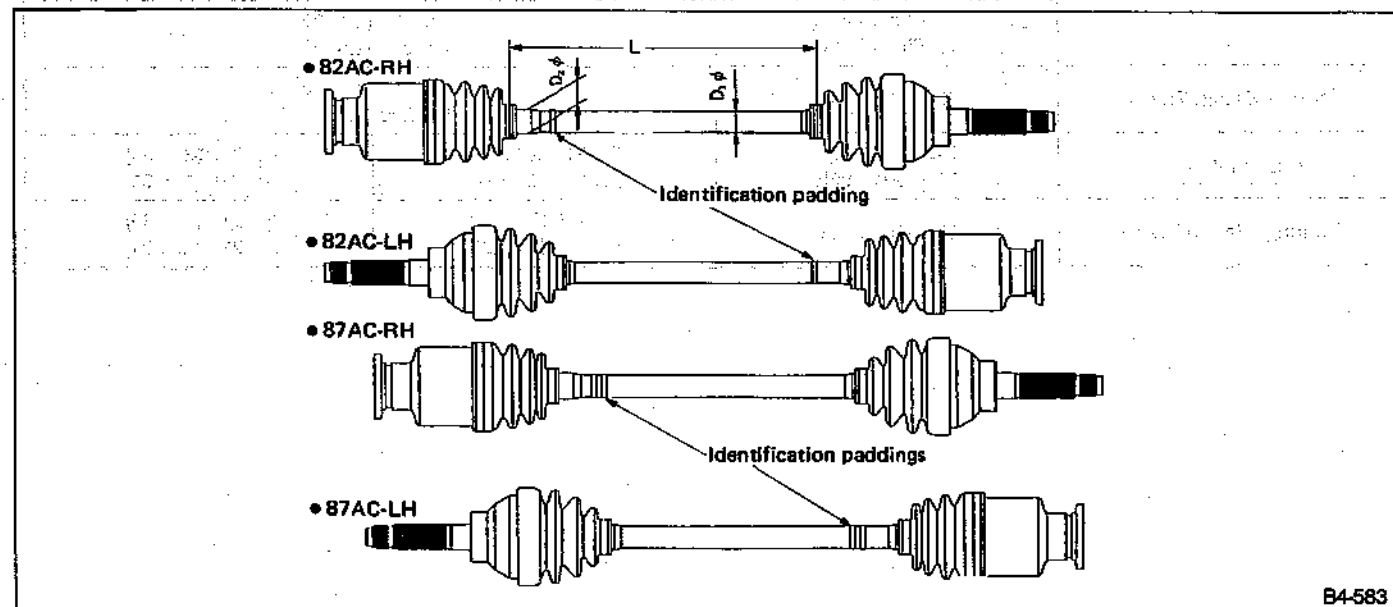


B4-582

Fig. 11

4. REAR DRIVE SHAFT ASSEMBLY (4WD)

Type of axle shaft ASSY	No. of identification paddings on shaft	Distance between inner and outer boots (L) mm (in)	SHAFT	
			Diameter (D) mm (in)	
			D ₁	D ₂
82AC-RH	1 (One)	304 (11.97)	21.2 (0.835)	24 (0.94)
82AC-LH		294 (11.57)		21.2 (0.835)
87AC-RH	2 (Two)	277 (10.91)	22.22 (7/8)	25 (0.98)
87AC-LH		267 (10.51)		22.22 (7/8)



B4-583

Fig. 12

WHEELS AND AXLES

[SOB0] 4-2

5. APPLICATION TABLE

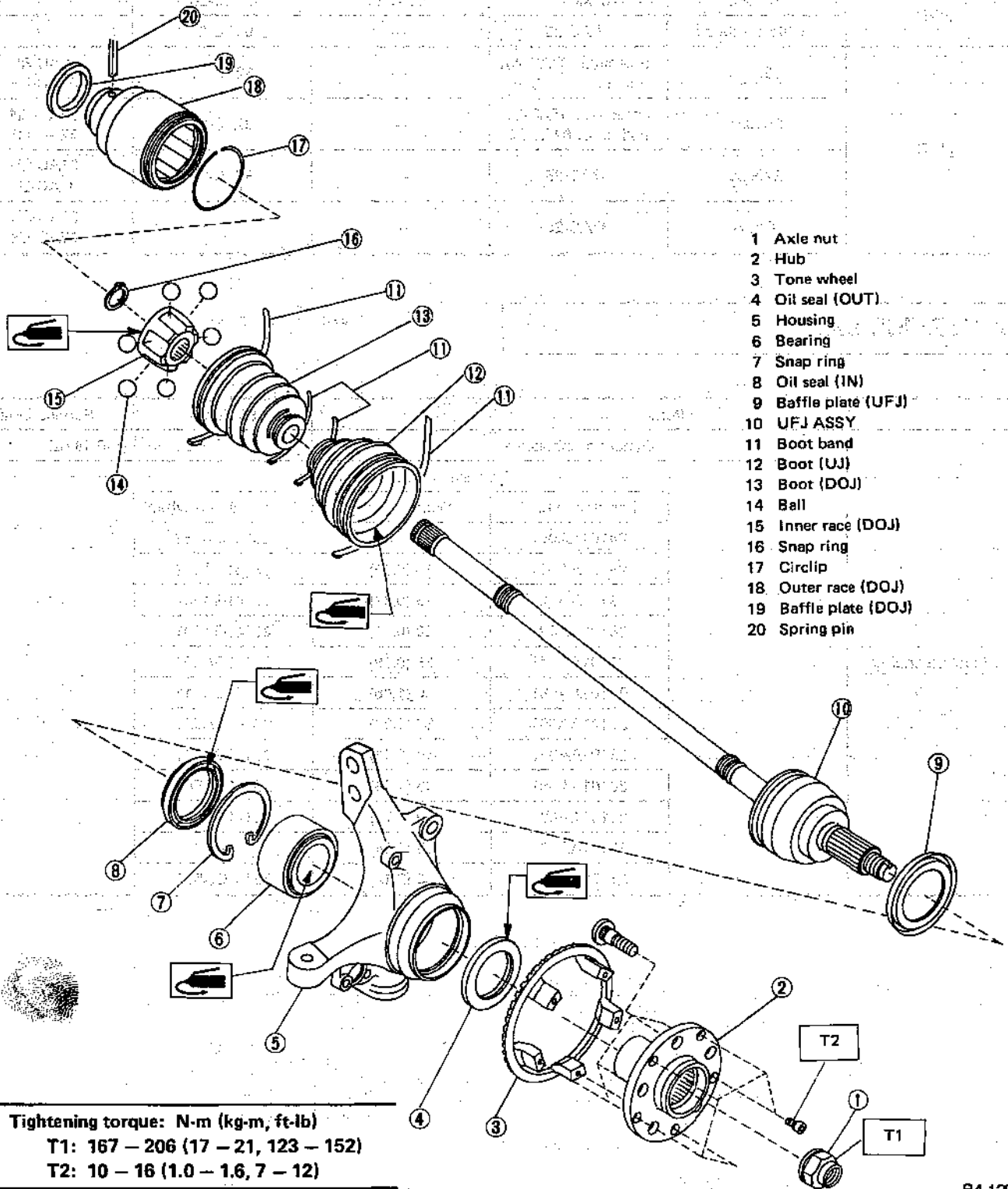
	Power unit	Front drive shaft			Rear drive shaft
		5MT	3AT	4AT	
FWD	1800cc	87AC-23	87AC-23	87AC-25	—
	2000cc, 2200cc	95AC-25	—	95AC-25	—
4WD	1800cc	Selective: 87AC-25 Full time: 82AC-25	—	82AC-25	82AC-RH 82AC-LH
	2000cc	Selective: 95AC-25 Full time: 82AC-25	—	82AC-25	82AC-RH 82AC-LH
	2200cc	87AC-25	—	87AC-25	87AC-RH 87AC-LH
	Turbo	87AC-25	—	—	87AC-RH 87AC-LH

B: SERVICE DATA

Item	Standard	Service Limit	
	Dynamic unbalance		
	Less than 5 g (0.18 oz)		
Wheel balancing	Balance weight part number		
	For steel wheel	Weight g (oz)	For aluminum wheel
	28101AA001	5 (0.18)	23141GA462
	28101AA011	10 (0.35)	23141GA472
	28101AA021	15 (0.53)	23141GA482
	28101AA031	20 (0.71)	23141GA491
	28101AA041	25 (0.88)	23141GA501
	28101AA051	30 (1.06)	23141GA511
	28101AA061	35 (1.23)	23141GA521
	28101AA071	40 (1.41)	23141GA531
	28101AA081	45 (1.59)	23141GA541
	28101AA091	50 (1.76)	23141GA551
	28101AA101	55 (1.94)	—
28101AA111	60 (2.12)	23141GA571	

C COMPONENT PARTS

1. Front Axle



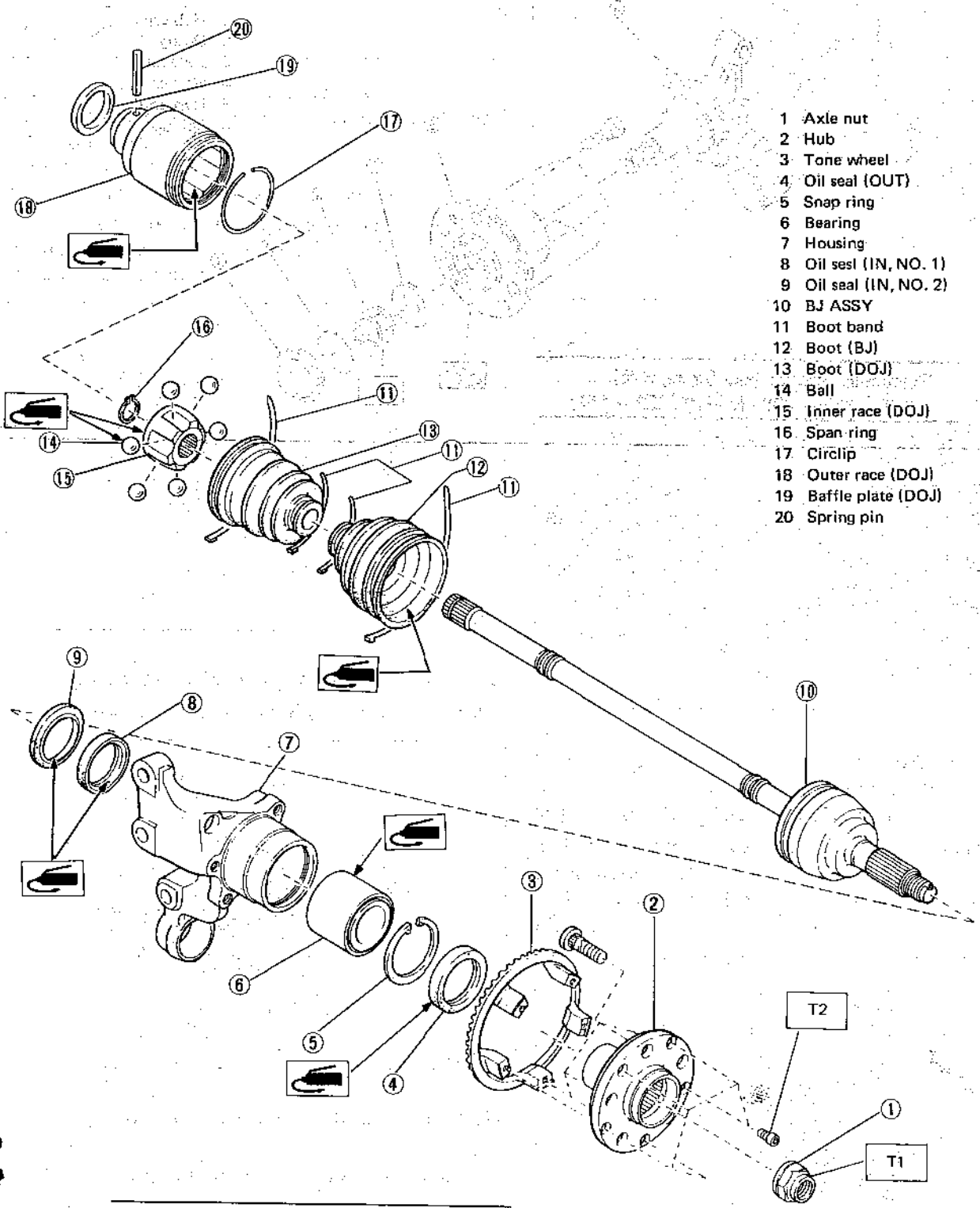
- 1 Axle nut
- 2 Hub
- 3 Tone wheel
- 4 Oil seal (OUT)
- 5 Housing
- 6 Bearing
- 7 Snap ring
- 8 Oil seal (IN)
- 9 Baffle plate (UFJ)
- 10 UFJ ASSY
- 11 Boot band
- 12 Boot (UJ)
- 13 Boot (DOJ)
- 14 Ball
- 15 Inner race (DOJ)
- 16 Snap ring
- 17 Circlip
- 18 Outer race (DOJ)
- 19 Baffle plate (DOJ)
- 20 Spring pin

Tightening torque: N·m (kg·m, ft·lb)
 T1: 167 - 206 (17 - 21, 123 - 152)
 T2: 10 - 16 (1.0 - 1.6, 7 - 12)

Fig. 13

2. Rear Axle (4WD)

1. 4WD



- 1 Axle nut
- 2 Hub
- 3 Tone wheel
- 4 Oil seal (OUT)
- 5 Snap ring
- 6 Bearing
- 7 Housing
- 8 Oil seal (IN, NO. 1)
- 9 Oil seal (IN, NO. 2)
- 10 BJ ASSY
- 11 Boot band
- 12 Boot (BJ)
- 13 Boot (DOJ)
- 14 Ball
- 15 Inner race (DOJ)
- 16 Span ring
- 17 Circlip
- 18 Outer race (DOJ)
- 19 Baffle plate (DOJ)
- 20 Spring pin

Tightening torque: N·m (kg·m, ft·lb)
 T1: 167 – 206 (17 – 21, 123 – 152)
 T2: 10 – 16 (1.0 – 1.6, 7 – 12)

14

B4-585

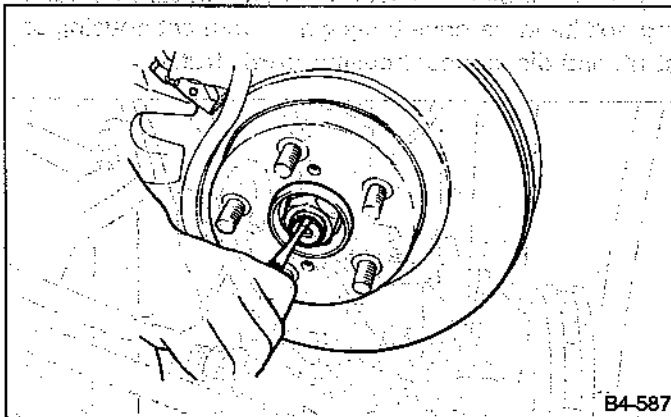
W SERVICE PROCEDURE

1. Front Axle

A: REMOVAL

- 1) Disconnect ground cable from battery.
- 2) Jack up vehicle, support it with safety stands, and remove front wheels.
- 3) Unlock axle nut.
- 4) Remove axle nut using a socket wrench.

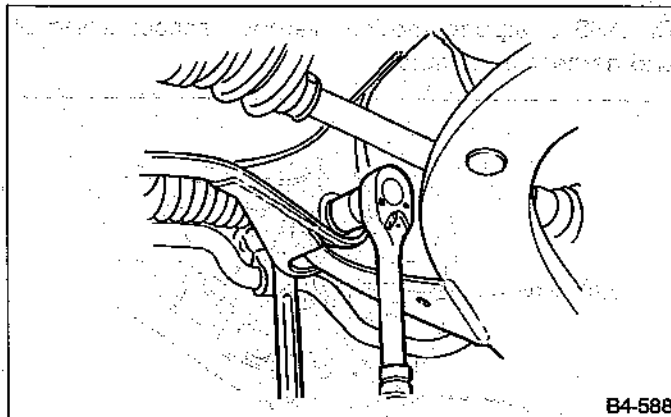
Be sure to loose and retighten axle nut after removing wheel from vehicle. Failure to follow this rule may damage wheel bearings.



B4-587

Fig. 16

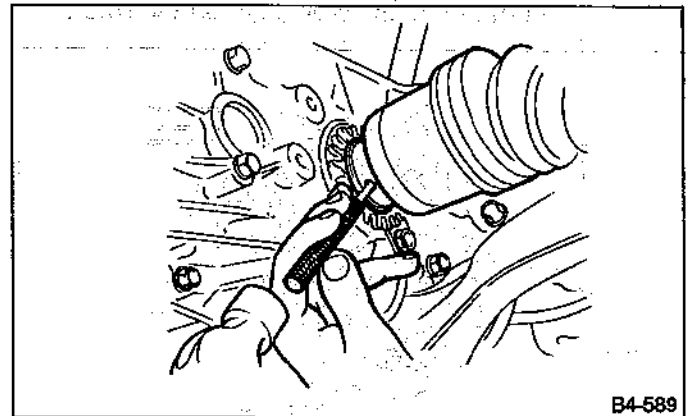
- 5) Remove transverse link from front crossmember. Discard old self-locking nut. Replace with a new one.



B4-588

Fig. 17

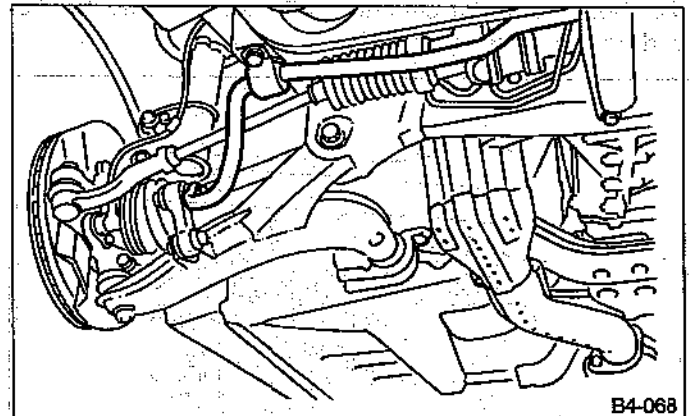
- 6) Remove spring pin which secures transmission spindle to DOJ. Discard old spring pin. Replace with a new one.



B4-589

Fig. 18

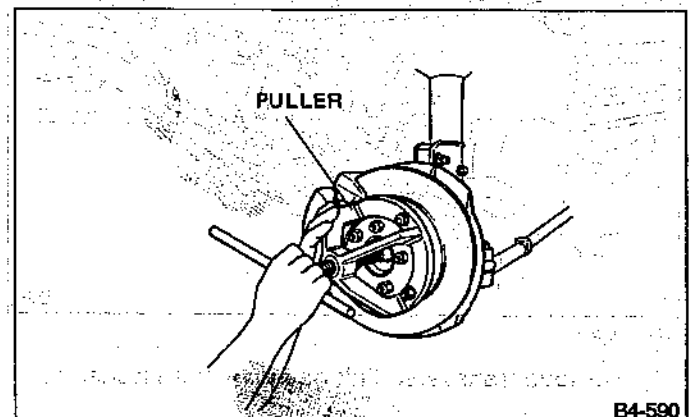
- 7) Remove stabilizer clamp.



B4-068

Fig. 19

- 8) Remove DOJ from transmission spindle.
- 9) Remove front drive shaft ASSY from hub. If it is hard to remove, use a PULLER (927070000).
 - a. Be careful not to damage oil seal lip when removing front drive shaft.
 - b. When replacing front drive shaft, also replace inner oil seal.



B4-590

Fig. 20

- 10) Remove disc brake caliper from housing, and suspend it from strut using a wire.

- 11) Remove disc rotor from hub COMPL.
If disc rotor seizes up within hub, drive disc rotor out by installing an 8-mm bolt in screw hole on the rotor.

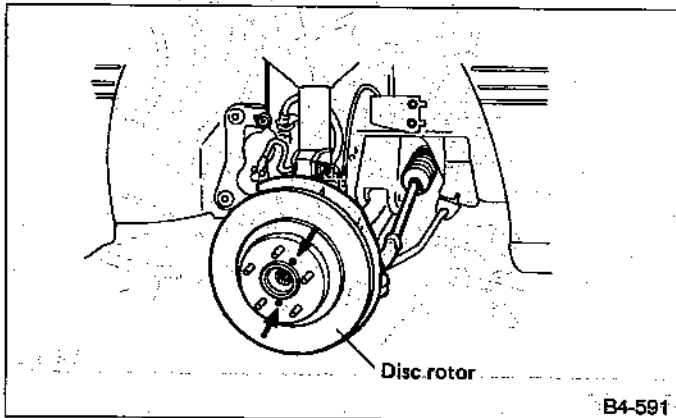


Fig. 21

- 12) Remove cotter pin and castle nut which secure tie-rod end to housing knuckle arm.

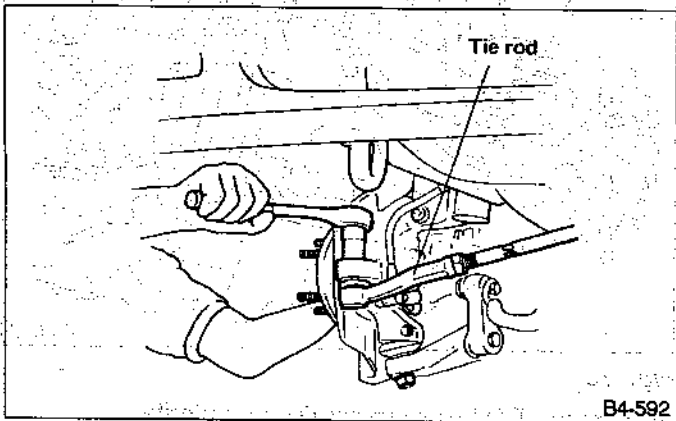


Fig. 22

- 13) Using a puller, remove tie rod ball joint from knuckle arm.

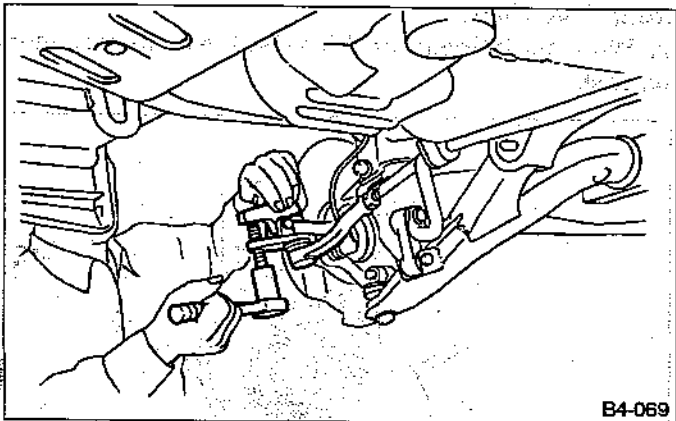


Fig. 23

- 14) Remove transverse link ball joint from housing.

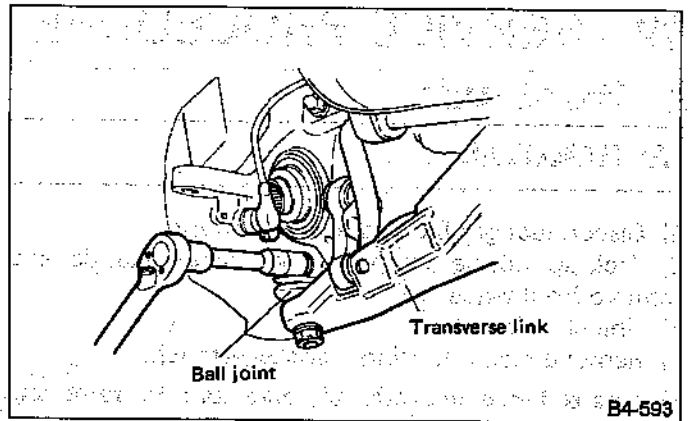


Fig. 24

- 15) After scribing an alignment mark on camber adjusting bolt head, remove bolts which connect housing and strut, and disconnect housing from strut.

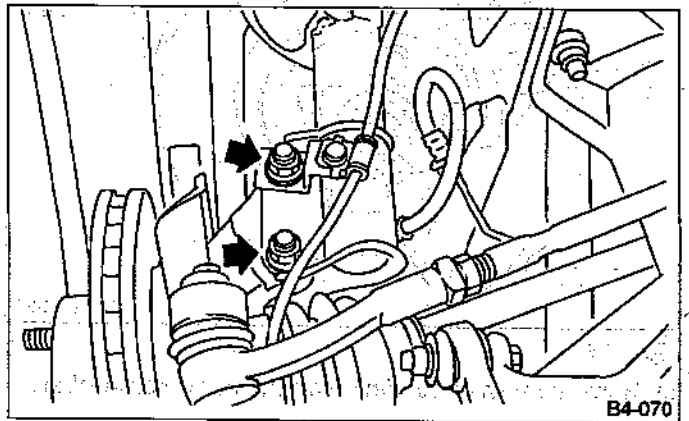


Fig. 25

- On ABS equipped models, remove sensor assembly and harness in advance.

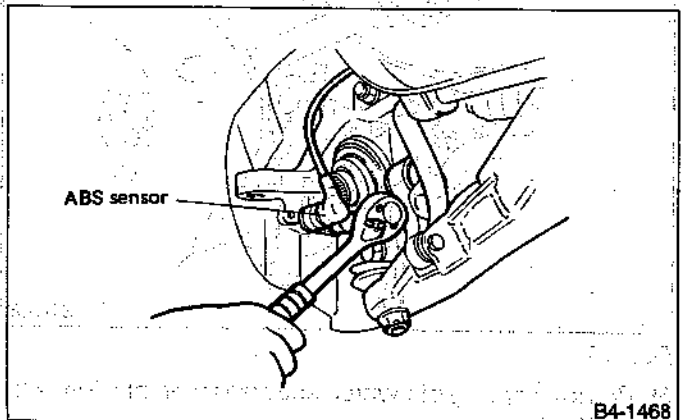


Fig. 26

- Be sure to use soft jaws (such as aluminum plates) when placing the mating surfaces of housing and strut in a vise.

B: DISASSEMBLY

- 1) Using HUB STAND (927080000), support housing and hub ASSY securely.
- 2) Attach HUB REMOVER (927060000) to housing and drive hub COMPL out.

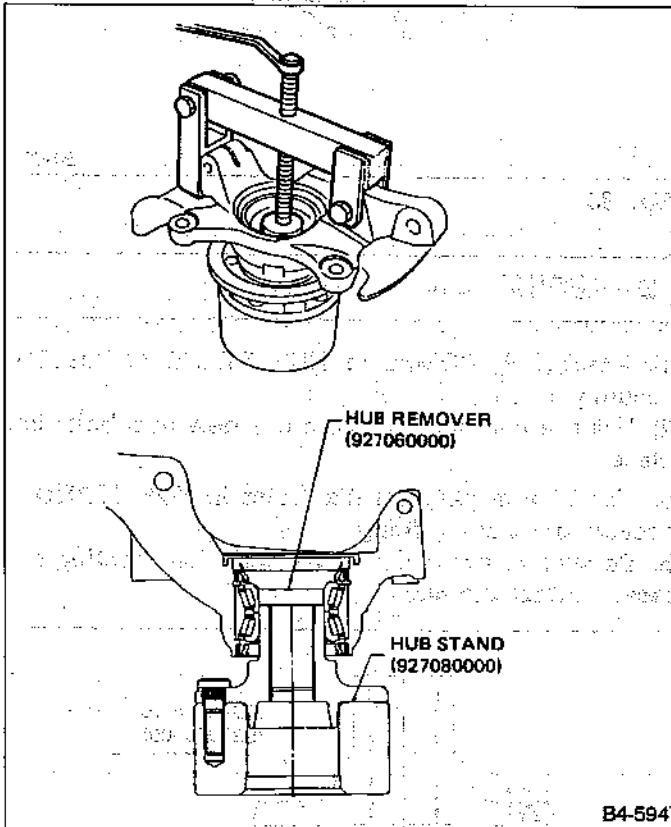


Fig. 27

If inner bearing race remains in the hub, remove it with a suitable tool (commercially available).

- a. Be careful not to scratch polished area of hub.
- b. Be sure to install inner race on the side of outer race from which it was removed.

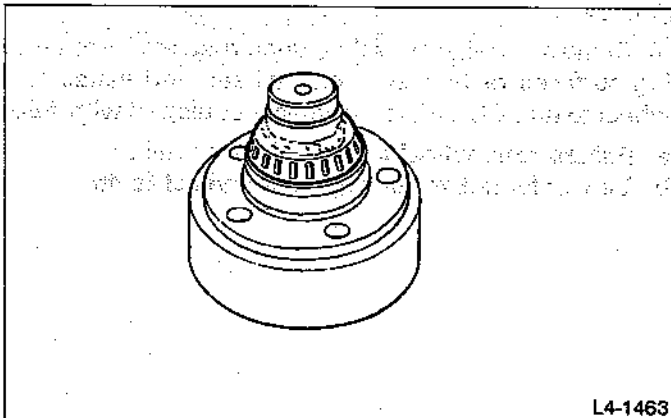


Fig. 28

- 3) Remove disc cover from housing.

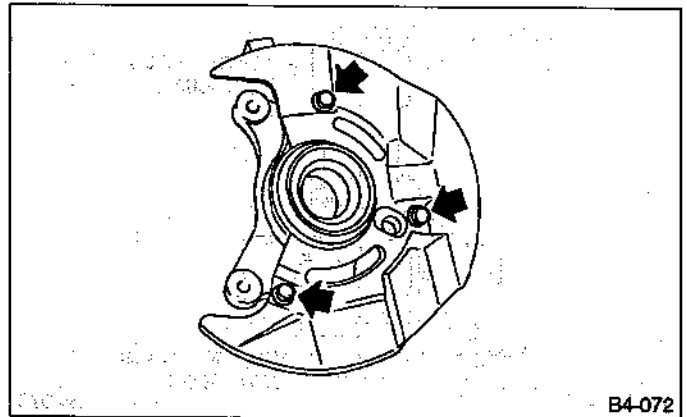


Fig. 29

- 4) Using a standard screwdriver, remove outer and inner oil seals.

Do not use old oil seals.

- 5) Using pliers, remove snap ring.

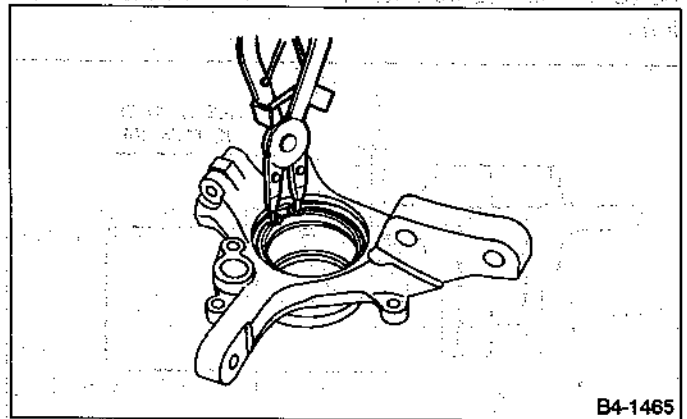


Fig. 30

- 6) Using HOUSING STAND (927400000), support housing securely.

- 7) Using BEARING REMOVER (927100000), press inner race to drive out outer bearing.

- a. Do not remove outer race unless it is faulty.
- b. Discard outer race after removal.
- c. Do not replace inner or outer race separately; always replace as a unit.

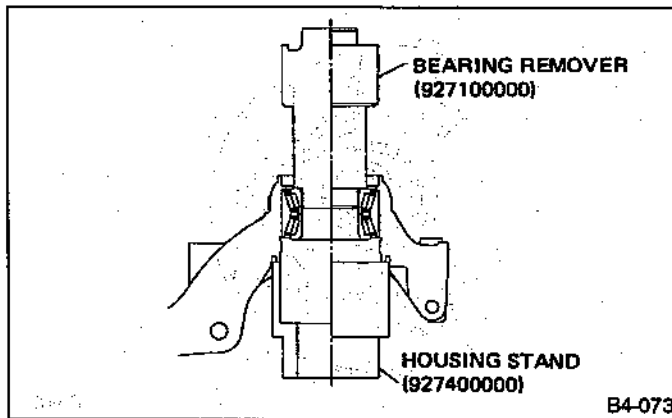


Fig. 31

- 8) Loosen bolts which secure tone wheel to hub. Remove tone wheel (only vehicle equipped with ABS).
- 9) Using HUB STAND (927080000) and a hydraulic press, drive hub bolts out.

Be careful not to hammer hub bolts. This may deform hub.

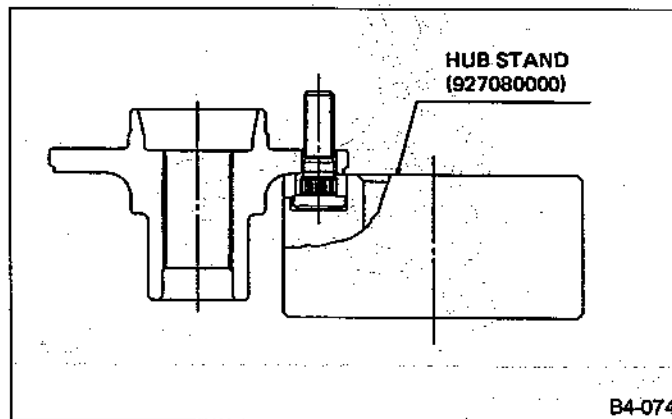


Fig. 32

C: INSPECTION

Check the removed parts for wear and damage. If defective, replace with a new one.

- a. If bearing is faulty, replace it as the bearing set.
- b. Be sure to replace oil seal at every overhaul.

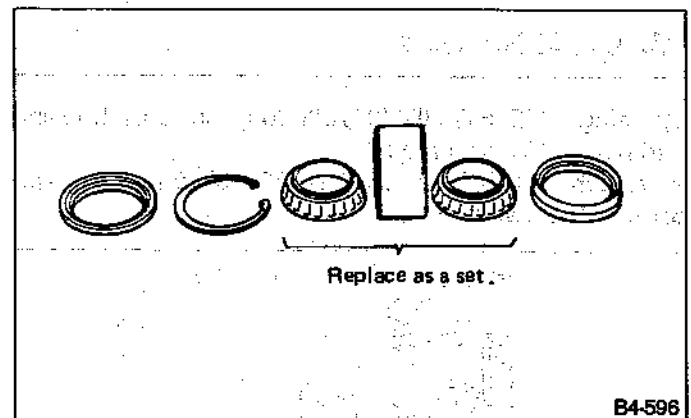


Fig. 33

D: ASSEMBLY

- 1) Attach hub COMPL to HUB STAND (927080000) securely.
- 2) Using a hydraulic press, press new hub bolts into place.
 - a. Use 12 mm (0.47 in) dia. holes in HUB STAND to prevent bolts from tilting.
 - b. Be sure to press hub bolts until their seating surfaces contact the hub.

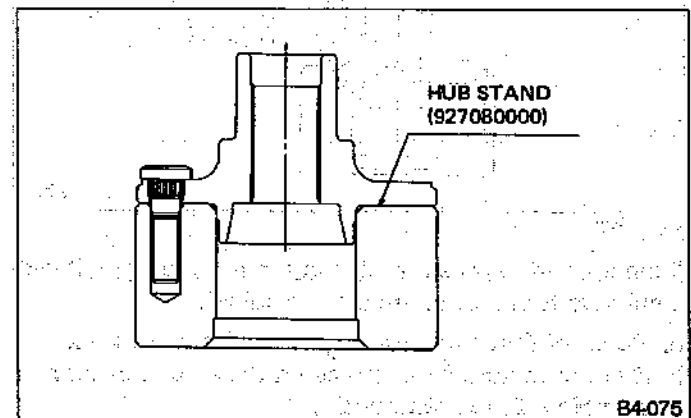


Fig. 34

- 3) Remove foreign particles (dust, rust, etc.) from mating surfaces of hub and tone wheel, and install tone wheel to hub COMPL (only vehicle equipped with ABS).
 - a. Ensure tone wheel closely contacts hub.
 - b. Be careful not to damage tone wheel teeth.

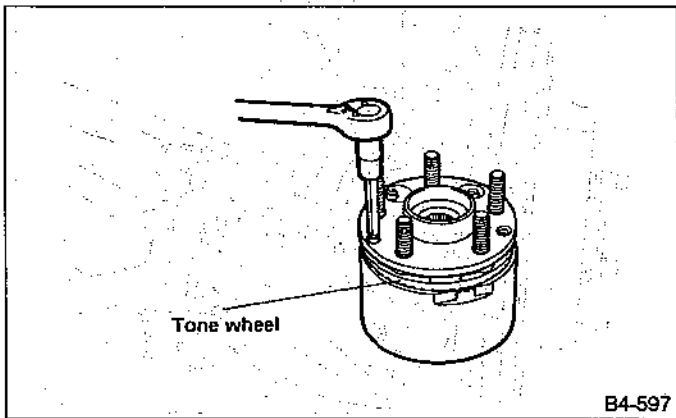


Fig. 35

- 4) Clean dust or foreign particles from inside the housing.
- 5) Using HOUSING STAND (927400000) and BEARING REMOVER (927100000), press a new bearing into place.

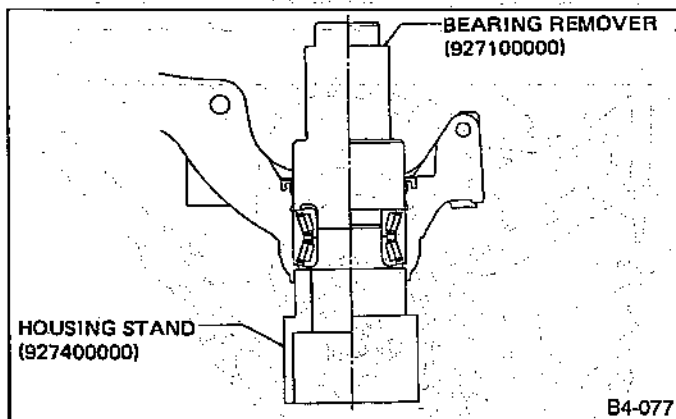


Fig. 36

- a. Always press outer race when installing bearing.
- b. Be careful not to remove plastic lock from inner race when installing bearing.
- c. Charge bearing with new grease when outer race is not removed.
- 6) Install snap ring in its groove.
Make sure to install it firmly to groove.
- 7) Using OIL SEAL INSTALLER (927410000), press outer oil seal until it contacts the bottom of housing.

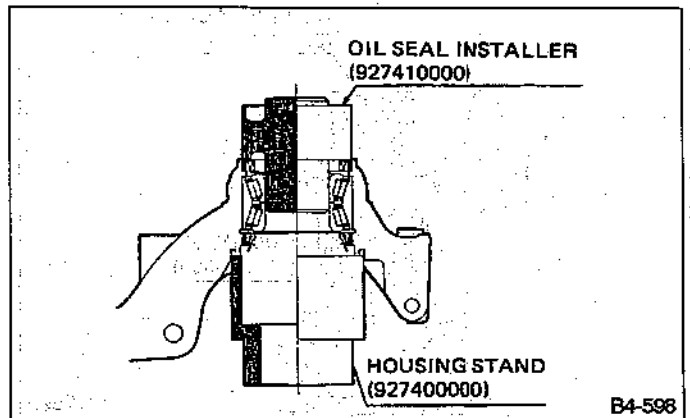


Fig. 37

- 8) Using OIL SEAL INSTALLER (927410000), press inner oil seal until it contacts circlip.

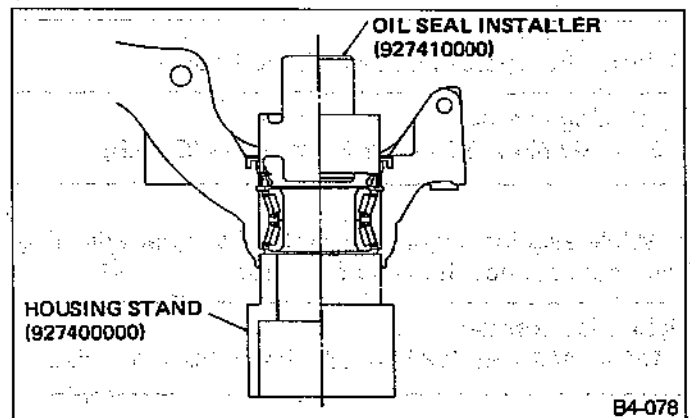


Fig. 38

- 9) Invert HOUSING STAND and housing.
- 10) Apply sufficient grease to oil seal lip.

Specified grease:
SHELL 6459N

- a. If specified grease is not available, remove bearing grease and apply Auto Rex A instead.
- b. Do not mix different types of grease.
- 11) Install disc cover to housing the three bolts.

Tightening torque:

10 — 18 N·m (1.0 — 1.8 kg-m, 7 — 13 ft-lb)

- 12) Attach hub COMPL to HUB STAND (927080000) securely.
- 13) Clean dust or foreign particles from the polished surface of hub.
- 14) Using HUB INSTALLER (927120000), press bearing into hub by driving inner race.

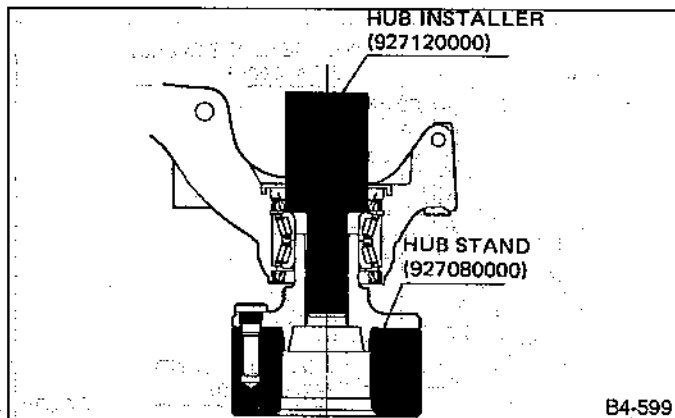


Fig. 39

E: INSTALLATION

- 1) Install transverse link ball joint to housing.

Tightening torque:

38 — 50 N·m (3.9 — 5.1 kg-m, 28 — 37 ft-lb)

- 2) While aligning alignment mark on camber adjusting bolt head, connect housing and strut.

Tightening torque:

132 — 162 N·m (13.5 — 16.5 kg-m, 98 — 119 ft-lb)

- 3) Install speed sensor and harness on housing (only vehicle equipped with ABS).
- 4) Install disc rotor on hub.
- 5) Install disc brake caliper on housing.

Tightening torque:

49 — 69 N·m (5 — 7 kg-m, 36 — 51 ft-lb)

- 6) Install front drive shaft. (Ref. to 4-2 [W4E0].)
- 7) Connect transverse link to front crossmember, and temporarily tighten.

Use a new self-locking nut:

- 8) Connect stabilizer clamp.
- 9) Install tie-rod end ball joint on housing knuckle arm. (Ref. to 4-3 [W3E0].)

Tightening torque:

25 — 29 N·m (2.5 — 3.0 kg-m, 18 — 22 ft-lb)

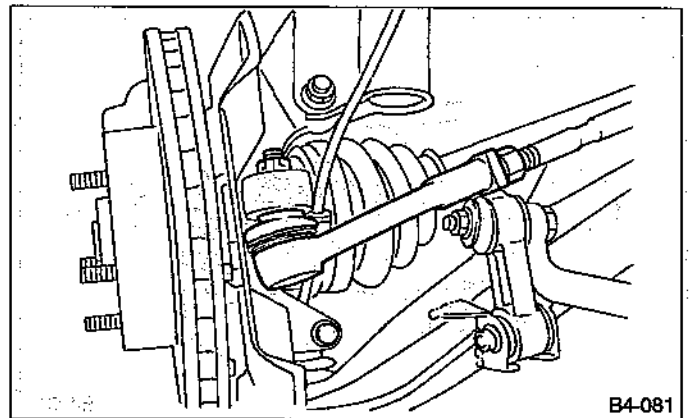


Fig. 40

- 10) While depressing brake pedal, tighten axle nut and lock it securely.

Tightening torque:

167 — 206 N·m (17 — 21 kg-m, 123 — 152 ft-lb)

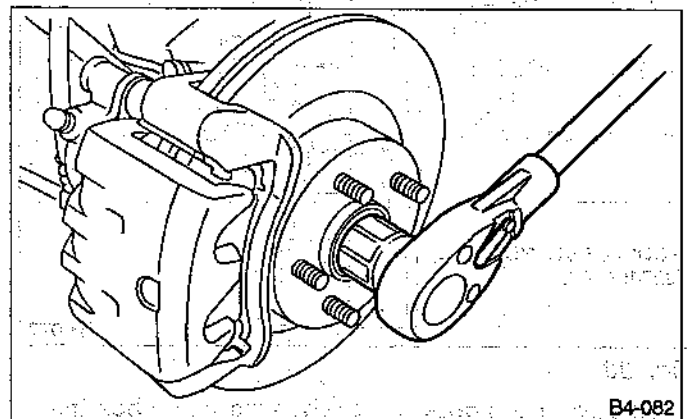
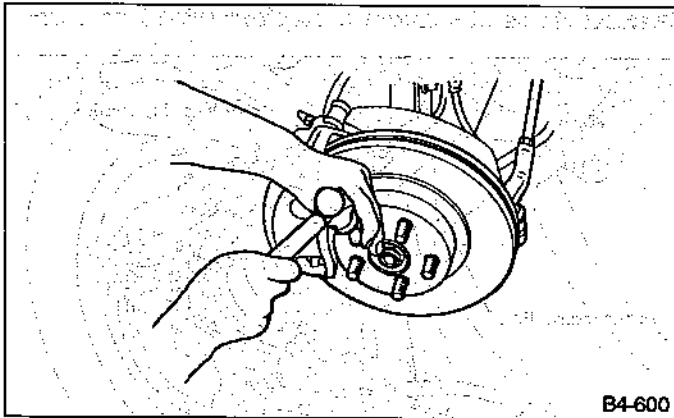


Fig. 41

- a. Use a new axle nut.
- b. Always tighten axle nut before installing wheel on vehicle. If wheel is installed and comes in contact with ground when axle nut is loose, wheel bearings may be damaged.

Be sure to tighten axle nut to specified torque. Do not overtighten it as this may damage wheel bearing.

- 11) After tightening axle nut, lock it securely.



B4-600

Fig. 42

12) Install wheel and tighten wheel nuts to specified torque.

Tightening torque:

78 — 98 N•m (8.0 — 10.0 kg-m, 58 — 72 ft-lb)

13) Securely tighten transverse link to front crossmember with tires on the ground.

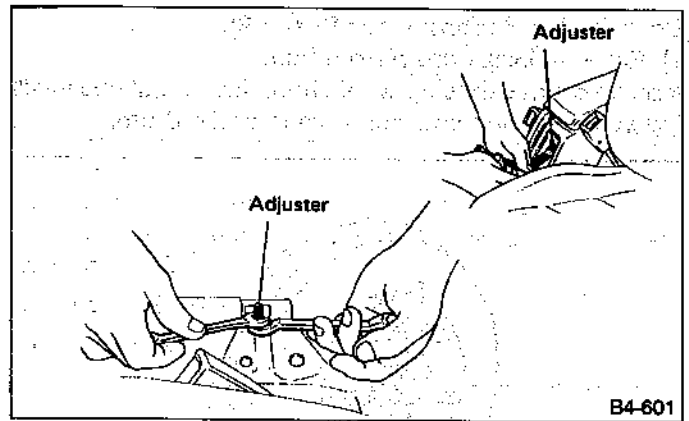
2. Rear Axle (4WD)

A: REMOVAL

- 1) Disconnect ground cable from battery.
- 2) Jack up vehicle, and remove rear wheel cap and wheels.

Be sure to loosen and retighten axle nut after removing wheel from vehicle. Failure to follow this rule may damage wheel bearings.

- 3) Unlock axle nut.
- 4) Remove axle nut using a socket wrench.
- 5) Return parking brake lever and loosen adjuster.

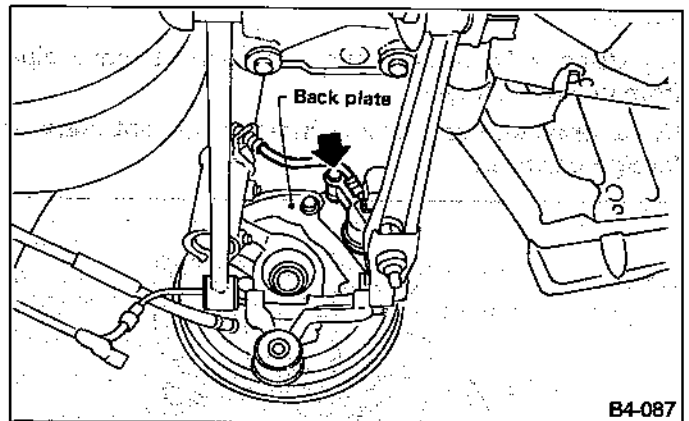


B4-601

Fig. 43

Disc brake: Perform steps 6) and 7).

6) Remove disc brake ASSY from back plate, and suspend it from strut using a piece of wire.



B4-087

Fig. 44

7) Remove disc rotor from hub.

If disc rotor seizes up within hub, drive it out by installing an 8-mm bolt into bolt hole in disc rotor.

8) Disconnect end of parking brake cable.

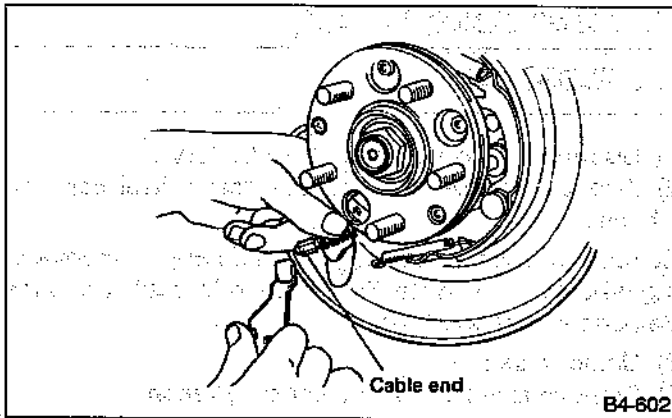


Fig. 45

Drum brake: Perform steps 8) and 9).

9) Remove brake drum from hub.

If brake drum seizes up within hub, drive it out by installing an 8-mm bolt into bolt hole in brake drum.

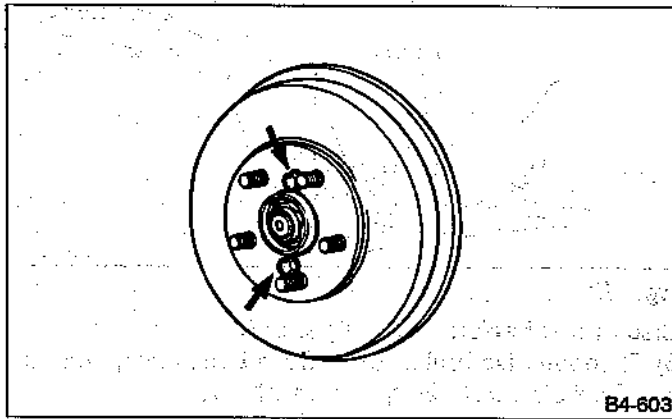


Fig. 46

10) Using a flare-nut wrench, disconnect brake pipe from wheel cylinder.

Cover open end of wheel cylinder to prevent entry of foreign particles.

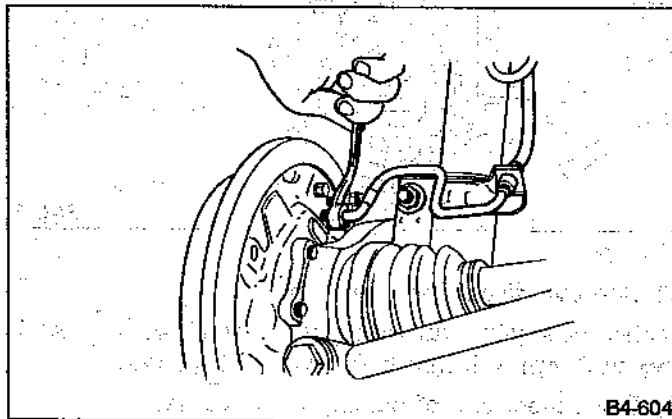


Fig. 47

11) Remove stabilizer clamp.

12) Remove bolts which secure lateral link ASSY to rear housing.

Discard old self-locking nut. Replace with a new one.

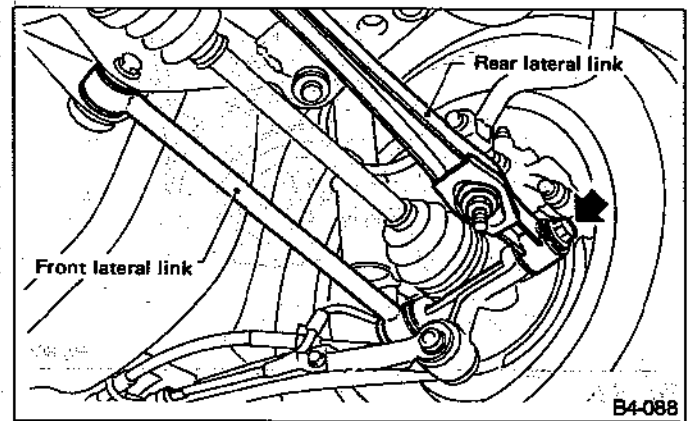


Fig. 48

13) Remove bolts which secure trailing link ASSY to rear housing.

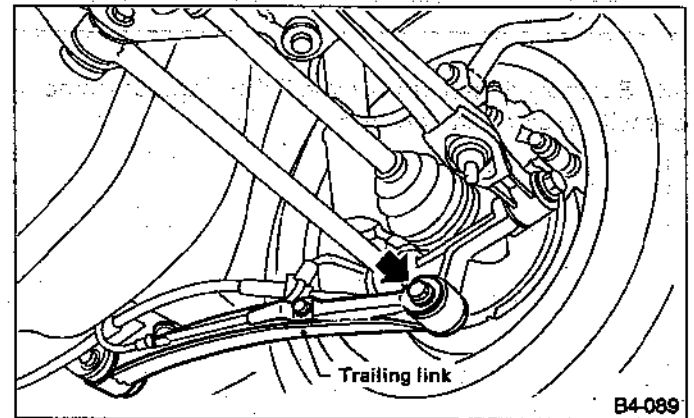


Fig. 49

Discard old self-locking nut. Replace with a new one.

14) Remove spring pin which secures rear differential spindle to DOJ.

Discard old spring pin. Replace with a new one.

15) Remove DOJ from rear differential spindle.

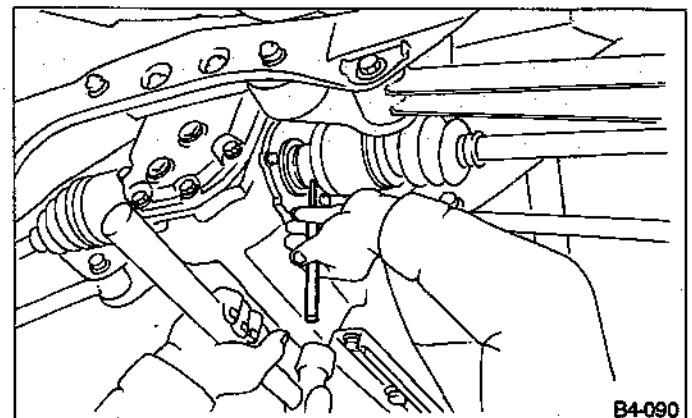


Fig. 50

16) Disengage BJ from housing splines, and remove rear drive shaft ASSY. If it is hard to remove, use a PULLER (927070000).

- a. Be careful not to damage oil seal lip when removing rear drive shaft.
- b. When rear drive shaft is to be replaced, also replace inner oil seal with a new one.

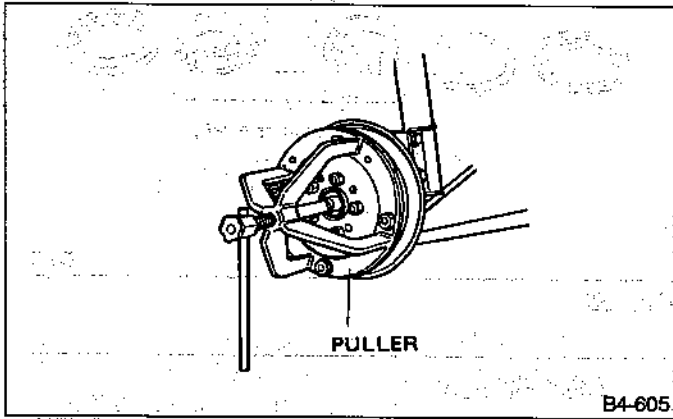


Fig. 51

- 17) Remove bolts which secure rear housing to strut, and separate the two.

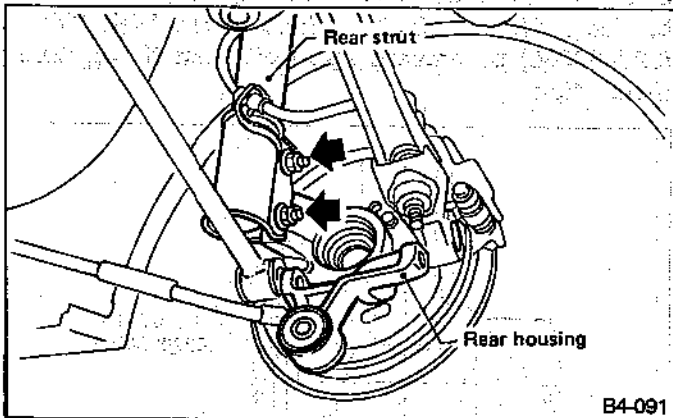


Fig. 52

- 18) Remove rear speed sensor from back plate (only vehicle equipped with ABS).

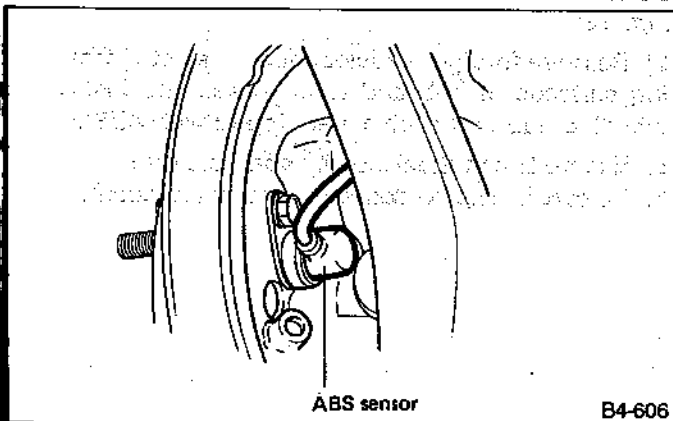


Fig. 53

B: DISASSEMBLY

- 1) Using HUB STAND (927080000) and HUB REMOVER (927420000), remove hub COMPL from rear housing.

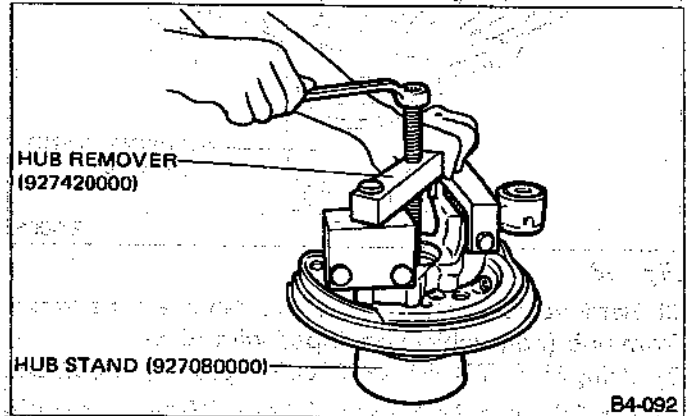


Fig. 54

- 2) Remove back plate from rear housing.
- 3) Using a standard screwdriver, remove outer and inner oil seals.

Use new oil seals.

- 4) Using plier, remove snap ring.

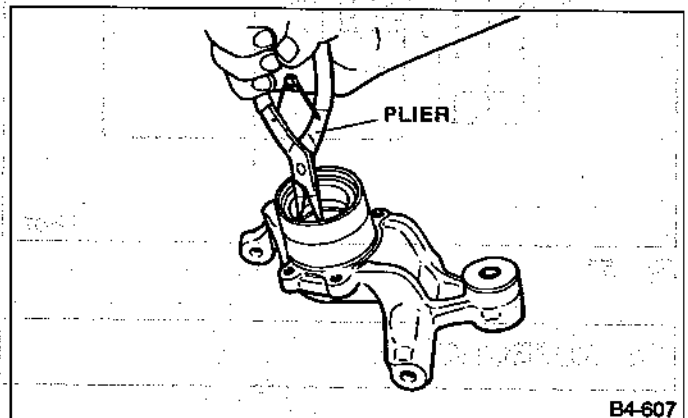


Fig. 55

- 5) Using HOUSING STAND (927430000) and BEARING REMOVER (927440000), remove bearing by pressing inner race.

- a. Do not remove bearing unless damaged.
- b. Do not re-use bearing after removal.

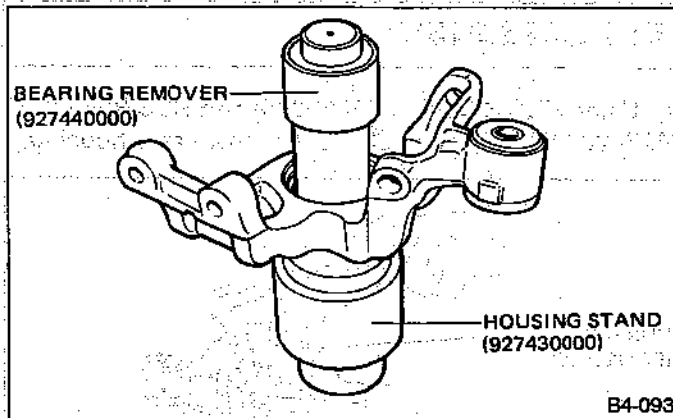


Fig. 56

- 6) Remove tone wheel bolts and remove tone wheel from hub (only vehicle equipped with ABS).
- 7) Using HUB STAND (927080000), press hub bolt out. **Be careful not to hammer hub bolts. This may deform hub.**

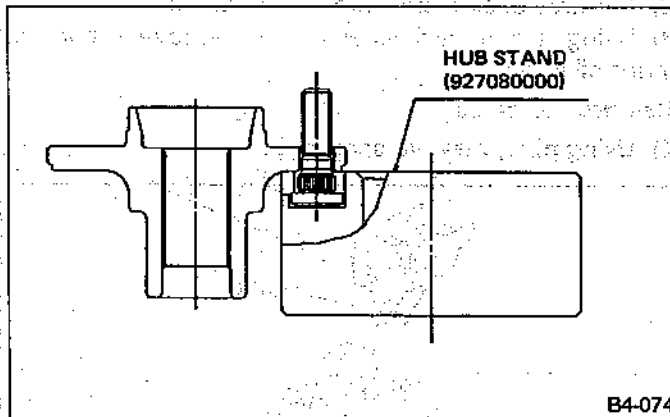


Fig. 57

C: INSPECTION

Check the removed parts for wear and damage. If defective, replace with a new one.

- a. If a bearing is faulty, replace it as the bearing set.
- b. Be sure to replace oil seal at every overhaul.

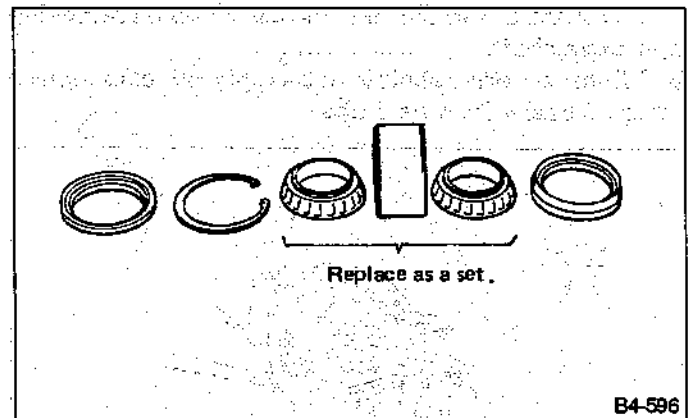


Fig. 58

D: ASSEMBLY

- 1) Using HUB STAND (927080000), press new hub bolt into place.
 - a. Ensure hub bolt closely contacts hub.
 - b. Use a 12 mm (0.47 in) hole in the HUB STAND (927080000) to prevent hub bolt from tilting during installation.

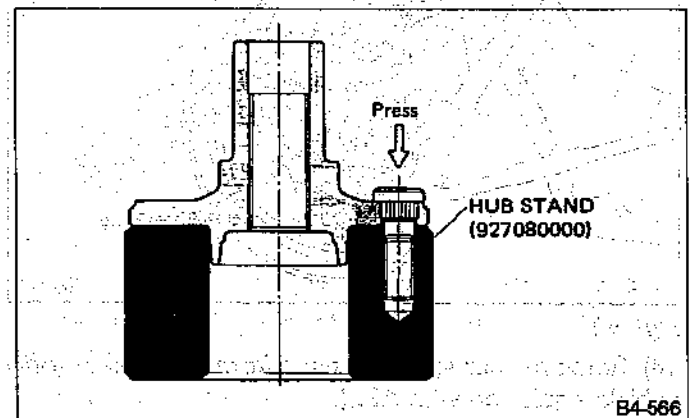
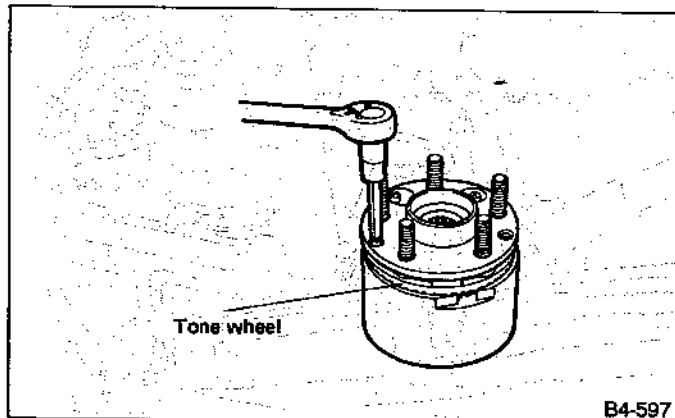


Fig. 59

- 2) Remove foreign particles (dust, rust, etc.) from mating surfaces of hub and tone wheel, and install tone wheel to hub (only vehicle equipped with ABS).
 - a. Ensure tone wheel closely contacts hub.
 - b. Be careful not to damage tone wheel teeth.

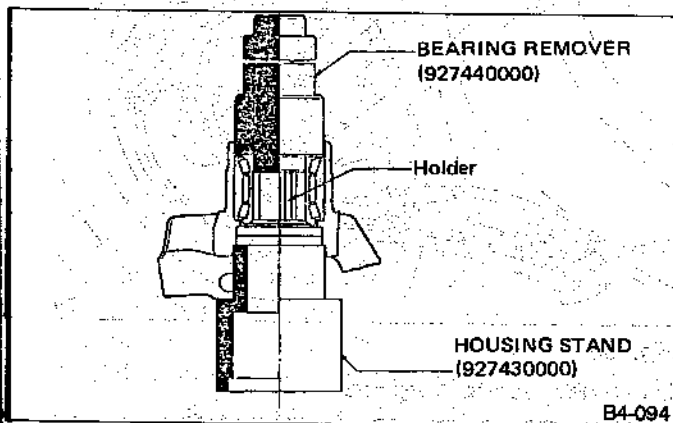


B4-597

Fig. 60

3) Clean housing interior completely. Using HOUSING STAND (927430000) and BEARING REMOVER (927440000), press bearing into housing.

- a. Always press outer race when installing bearing.
- b. Be careful not to remove plastic lock from inner race when installing bearing.
- c. Charge bearing with new grease when outer race is not removed.



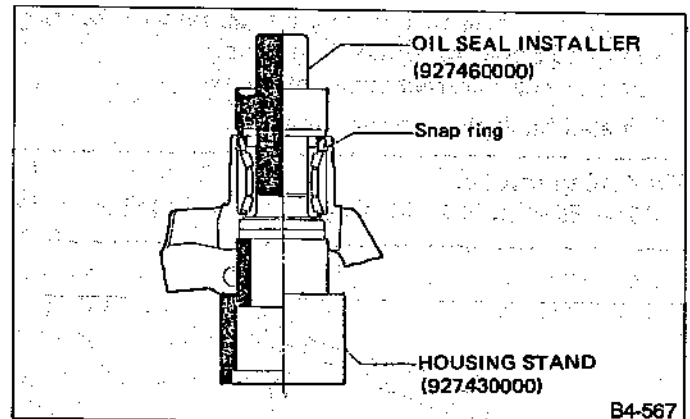
B4-094

Fig. 61

4) Install snap ring.

Ensure snap ring fits in groove properly.

5) Using HOUSING STAND (927430000) and OIL SEAL INSTALLER (927460000), press outer oil seal until it comes in contact with snap ring.

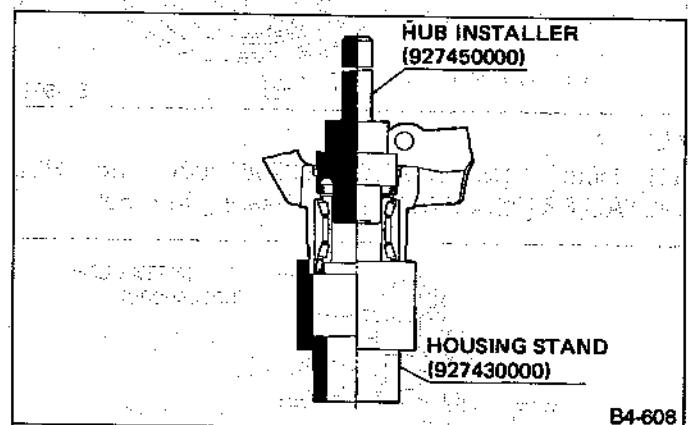


B4-567

Fig. 62

6) Invert both HOUSING STAND (927430000) and housing.

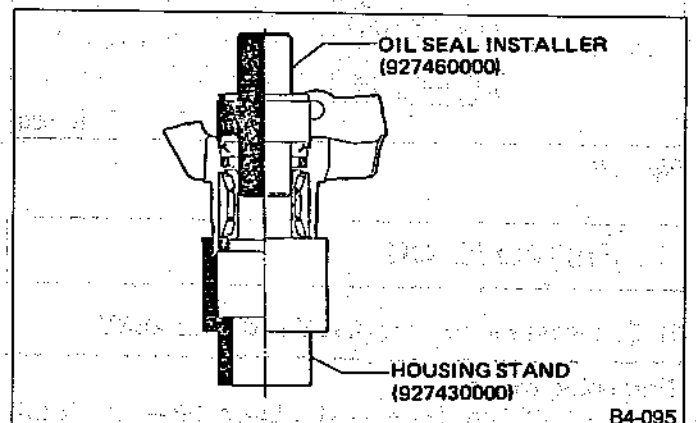
7) Using HUB INSTALLER (927450000), press inner oil seal into housing until it touches bottom.



B4-608

Fig. 63

8) Press sub seal into place.



B4-095

Fig. 64

9) Apply sufficient grease to oil seal lip.

Specified grease:
SHELL 6459N

- a. If specified grease is not available, remove bearing grease and apply Auto Rex A instead.
 b. Do not mix different types of grease.
- 10) Install back plate to rear housing.

Tightening torque:

46 — 58 N·m (4.7 — 5.9 kg-m, 34 — 43 ft-lb)

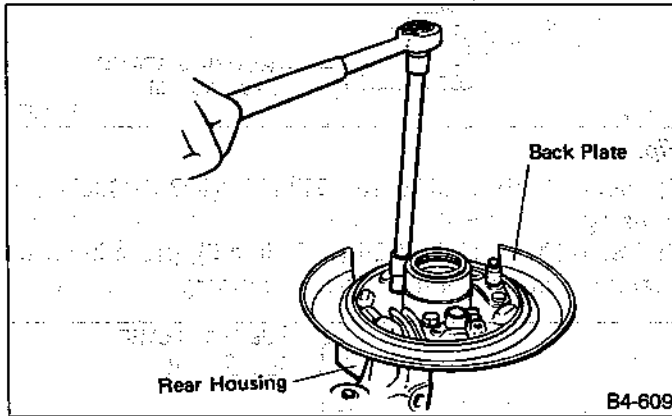


Fig. 65

- 11) Using HUB STAND (927080000) and HUB INSTALLER (927450000), press bearing into hub.

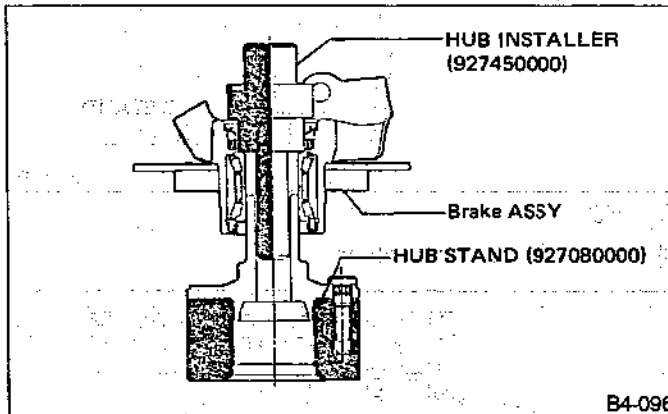


Fig. 66

E: INSTALLATION

- 1) Connect rear housing ASSY and strut ASSY.

Tightening torque:

132 — 162 N·m (13.5 — 16.5 kg-m, 98 — 119 ft-lb)

- 2) Install rear speed sensor to back plate (only vehicle equipped with ABS).

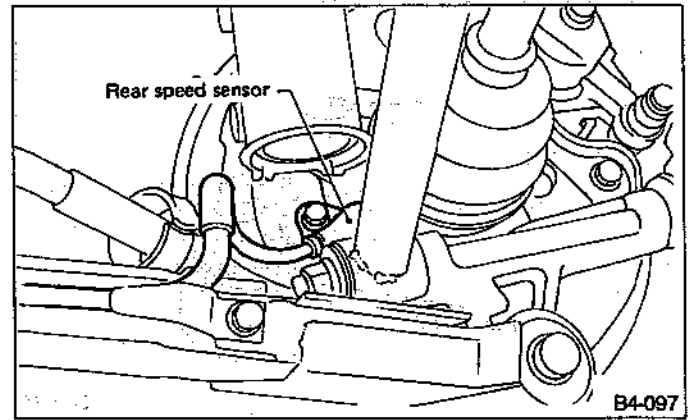


Fig. 67

- 3) Fit BJ (bell joint) to rear housing splines.
Be careful not to damage inner oil seal lip.
 4) Install rear drive shaft. (Ref. to 4-2 [W4E0].)
 5) Connect rear housing ASSY to trailing link ASSY.

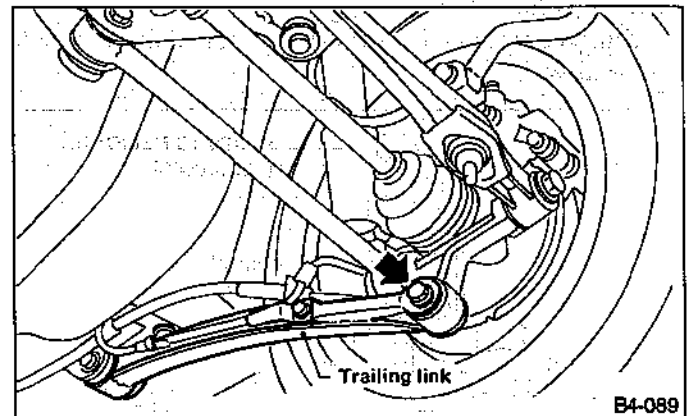


Fig. 68

Use a new self-locking nut.

Tightening torque:

98 — 127 N·m (10 — 13 kg-m, 72 — 94 ft-lb)

- 6) Connect rear housing ASSY to lateral link ASSY.
 Use a new self-locking nut.

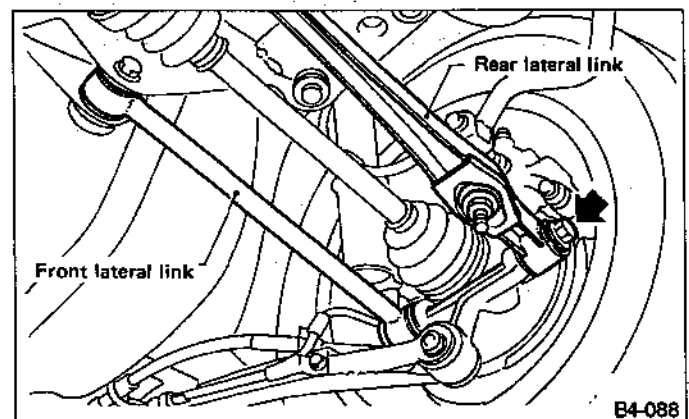


Fig. 69

Tightening torque:

118 — 157 N·m (12.0 — 16.0 kg-m, 87 — 116 ft-lb)

7) Install stabilizer clamp.

Disc brake: Perform steps 8) and 9).

8) Connect parking brake cable to disc brake ASSY.

9) Install disc rotor on rear housing ASSY.

10) Install disc brake ASSY on back plate.

Tightening torque:

46 — 58 N·m (4.7 — 5.9 kg-m, 34 — 43 ft-lb)

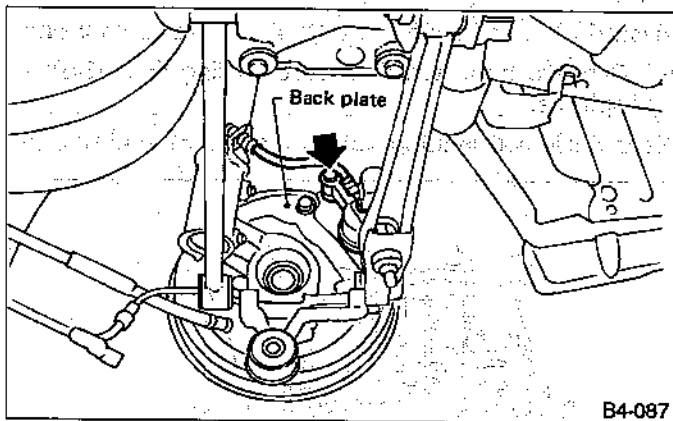


Fig. 70

Drum brake: Perform steps 10) through 13).

11) Clean brake pipe connection. Using a flare-nut wrench, connect brake pipe to wheel cylinder.

12) Connect parking brake cable to lever.

13) Install brake drum on rear housing ASSY.

14) Bleed air from brake system. (Ref. to 4-4 [W15B0].)

15) Adjust parking brake lever stroke by turning adjuster.

16) Move brake lever back to apply brakes. While depressing brake pedal, tighten axle nut using a socket wrench. Lock axle nut after tightening.

Tightening torque:

167 — 206 N·m (17 — 21 kg-m, 123 — 152 ft-lb)

a. Use a new axle nut.

b. Always tighten axle nut before installing wheel on vehicle. If wheel is installed and comes in contact with ground when axle nut is loose, wheel bearings may be damaged.

c. Be sure to tighten axle nut to specified torque. Do not overtighten it as this may damage wheel bearing.

17) Install wheel and tighten wheel nuts to specified torque.

Tightening torque:

78 — 98 N·m (8.0 — 10.0 kg-m, 58 — 72 ft-lb)

3. Rear Axle (FWD)

A: REMOVAL

1) Disconnect ground cable from battery.

2) Jack up vehicle, and remove rear wheel cap and wheels.

Be sure to loosen and retighten axle nut after removing wheel from vehicle. Failure to follow this rule may damage wheel bearings.

3) Pry hub cap off with a screwdriver placed between it and hub.

4) Unlock axle nut.

5) Remove axle nut using a socket wrench. Remove washer.

a. Do not re-use old axle nut. Replace with a new one.
b. Temporarily tighten axle nut to hold hub in place.

6) Return parking brake lever and loosen adjuster.

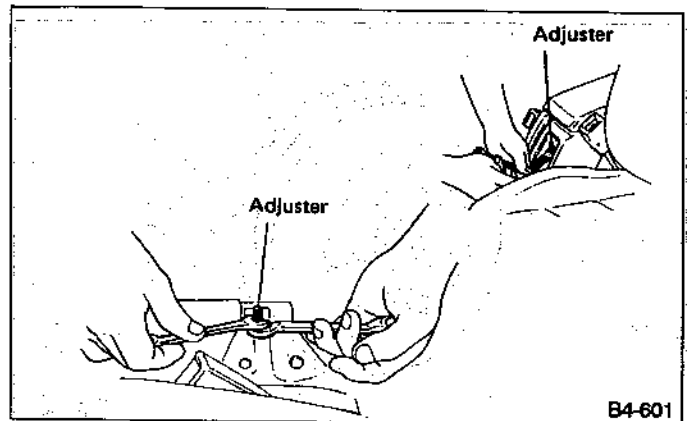


Fig. 71

Disc brake: Perform steps 7) through 9).

7) Remove disc brake ASSY from back plate. Suspend disc brake ASSY from strut using a wire.

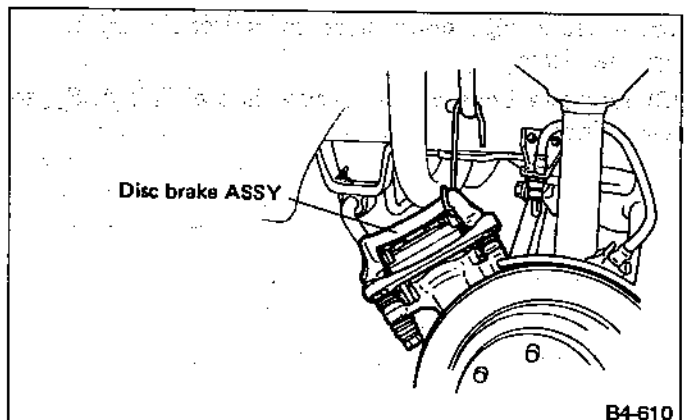


Fig. 72

8) Remove disc rotor from hub.

If disc rotor seizes up within hub, drive it out by installing an 8-mm bolt in bolt hole on disc rotor.

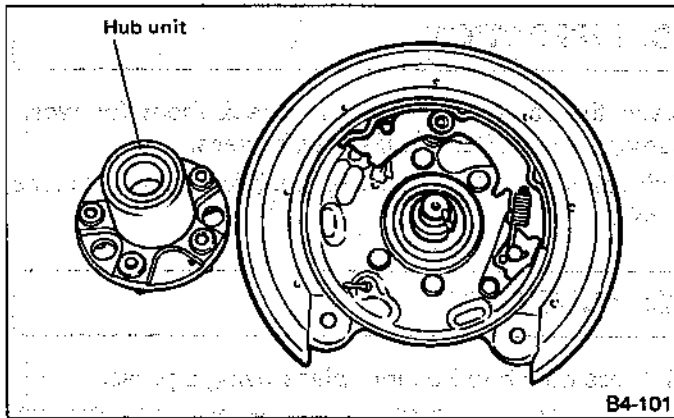


Fig. 82

E: INSTALLATION

- 1) Connect rear spindle ASSY to strut ASSY.

Tightening torque:

132 — 162 N·m (13.5 — 16.5 kg-m, 98 — 119 ft-lb)

Use a new self-locking nut.

- 2) Connect rear spindle ASSY to trailing link ASSY.

Tightening torque:

98 — 127 N·m (10.0 — 13.0 kg-m, 72 — 94 ft-lb)

Use a new self-locking nut.

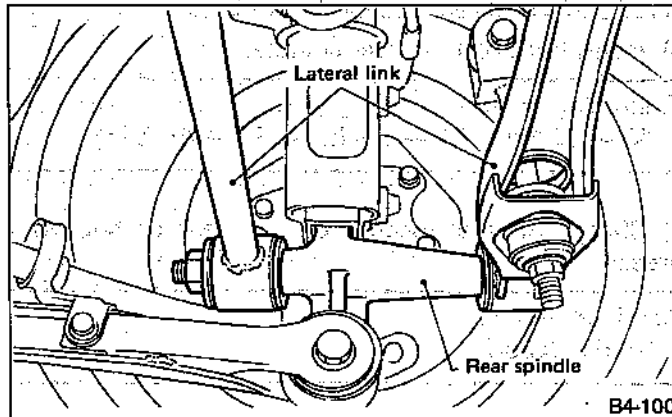


Fig. 83

- 3) Connect rear spindle ASSY to lateral link ASSY.

Tightening torque:

118 — 157 N·m (12.0 — 16.0 kg-m, 87 — 116 ft-lb)

Use new self-locking nut.

Disc brake: Perform steps 4) through 6).

- 4) Connect end of parking brake cable.
- 5) Install disc rotor to hub unit.

- 6) Install disc brake ASSY to back plate.

Tightening torque:

46 — 58 N·m (4.7 — 5.9 kg-m, 34 — 43 ft-lb)

Drum brake: Perform steps 7) through 10).

- 7) Completely clean brake pipe connection. Using a flare-nut wrench, connect brake pipe to wheel cylinder.
- 8) Connect parking brake cable to lever.
- 9) Install brake drum on hub unit.
- 10) Bleed air from brake system. (Ref. to 4-4 [W15B0].)
- 11) Tighten axle nut using a socket wrench, and lock securely.

Tightening torque:

167 — 206 N·m (17 — 21 kg-m, 123 — 152 ft-lb)

- a. Use a new axle nut.
 - b. Always tighten axle nut before installing wheel on vehicle. If wheel is installed and comes in contact with ground when axle nut is loose, wheel bearings may be damaged.
 - c. Be sure to tighten axle nut to specified torque. Do not overtighten it as this may damage wheel bearing.
- 12) Install O-ring to hub cap flange, and install hub cap by lightly tapping it with a plastic-faced hammer.
 - 13) Install wheel and tighten wheel nuts to specified torque.

Tightening torque (Wheel nut):

78 — 98 N·m (8.0 — 10.0 kg-m, 58 — 72 ft-lb)

4. Front and Rear Drive Shafts

A: REMOVAL

1. FRONT DRIVE SHAFT

- 1) Disconnect ground cable from battery.
- 2) Jack up vehicle, support it with safety stands (rigid rocks), and remove front wheel cap and wheels.
- 3) Unlock axle nut.
- 4) Remove axle nut using a socket wrench.

Be sure to loosen and retighten axle nut after removing wheel from vehicle. Failure to follow this rule may damage wheel bearings.

- 5) Remove transverse link from front crossmember.

Discard old axle nut. Replace with a new one.

- 6) Remove spring pin which secures transmission spindle to DOJ.

Use a new spring pin.

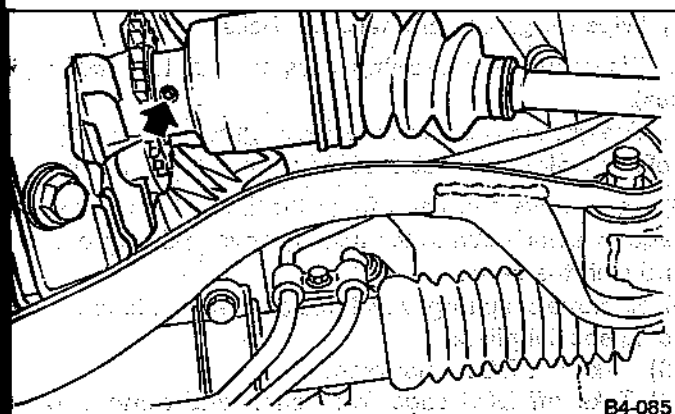


Fig. 84

- 7) Remove stabilizer clamp.
- 8) Remove front drive shaft ASSY. If it is hard to remove, use a PULLER (927070000).
 - a. Be careful not to damage oil seal lip when removing front drive shaft.
 - b. When front drive shaft is to be replaced, also replace inner oil seal.

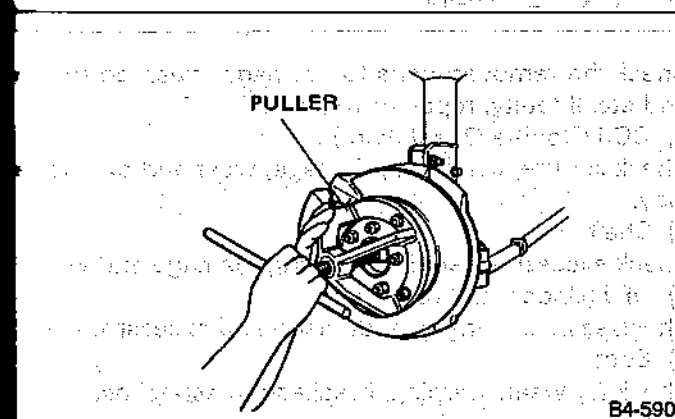


Fig. 85

2. REAR DRIVE SHAFT

- 1) Disconnect ground cable from battery.
- 2) Jack up vehicle, and remove rear wheel cap and wheels.
 - Be sure to loosen and retighten axle nut after removing wheel from vehicle. Failure to follow this rule may damage wheel bearings.
- 3) Unlock axle nut.
- 4) Remove axle nut using a socket wrench.
- 5) Remove stabilizer clamp.
- 6) Remove bolts which secure lateral link ASSY to rear housing.

Discard old self-locking nut. Replace with a new one.

- 7) Remove bolts which secure trailing link ASSY to rear housing.

Discard old self-locking nut. Replace with a new one.

- 8) Remove spring pin which secures rear differential spindle to DOJ.

Discard old spring pin. Replace with a new one.

- 9) Remove DOJ from rear differential spindle.

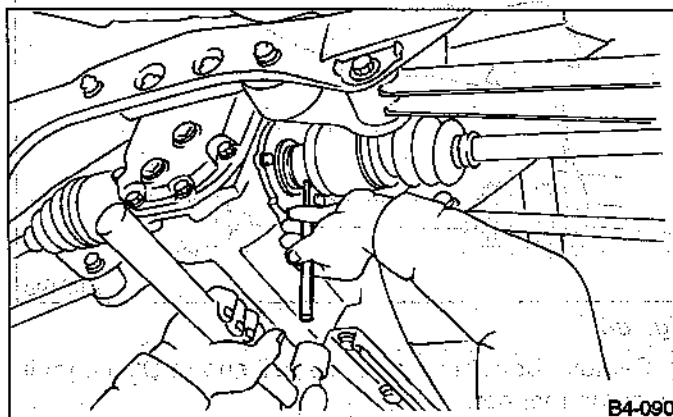


Fig. 86

- 10) Disengage BJ from housing splines, and remove rear drive shaft ASSY. If it is hard to remove, use a PULLER (927070000).

- a. Be careful not to damage oil seal lip when removing rear drive shaft.
- b. When rear drive shaft is to be replaced, also replace inner oil seal with a new one.

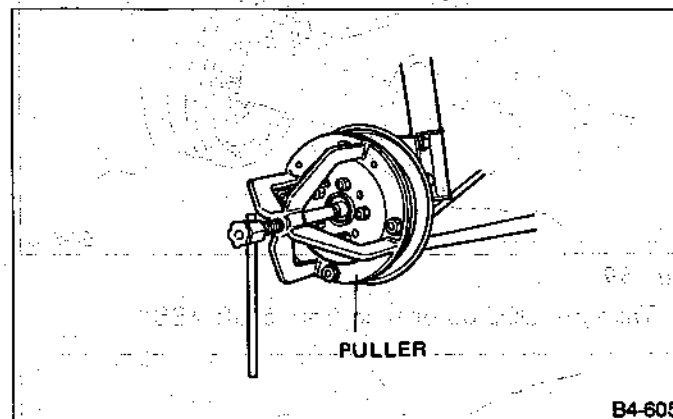
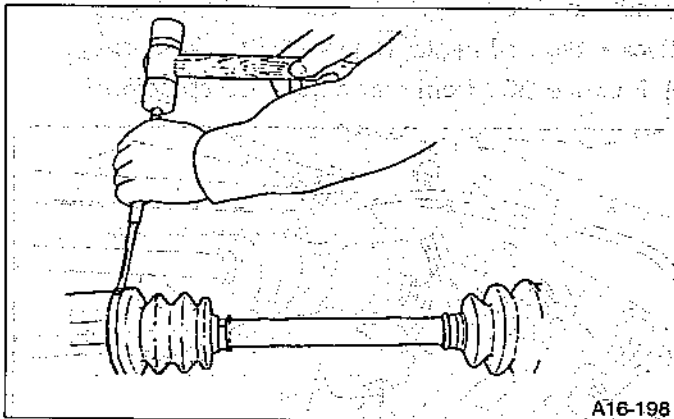


Fig. 87

B: DISASSEMBLY

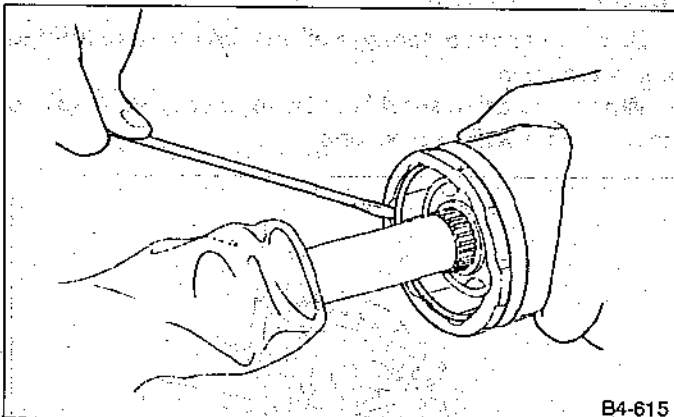
- 1) Straighten bent claw of larger end of DOJ boot.
- 2) Loosen band by means of screwdriver or pliers with care of not damaging boot.



A16-198

Fig. 88

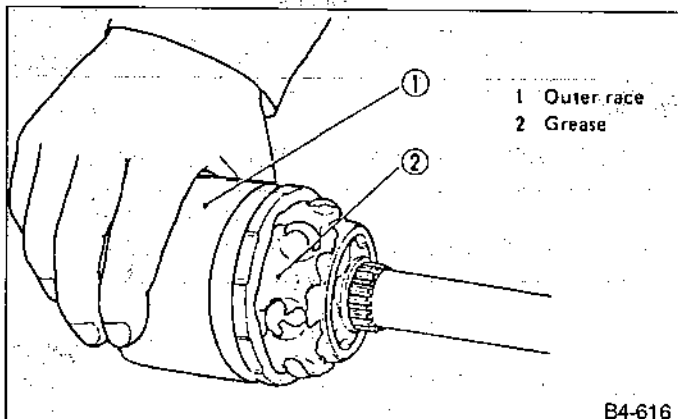
- 3) Remove boot band on the small end of DOJ boot in the same manner.
- 4) Remove the larger end of DOJ boot from DOJ outer race.
- 5) Pry and remove round circlip located at the neck of DOJ outer race with a screwdriver.



B4-615

Fig. 89

- 6) Take out DOJ outer race from shaft ASSY.



B4-616

Fig. 90

- 7) Wipe off grease and take out balls.

a. Disassemble exercising care not to lose balls (6 pcs).

b. The grease is a special grease (grease for constant-velocity joint). Do not confuse with other greases.

8) To remove the cage from the inner race, turn the cage by a half pitch to the track groove of the inner race and shift the cage.

9) Remove snap ring, which fixes inner race to shaft, by using special pliers.

10) Take out DOJ inner race.

11) Take off DOJ cage from shaft and remove DOJ boot.

Be sure to wrap shaft splines with vinyltape to prevent boot from scratches.

12) Remove UFJ/BJ boot in the same procedure as steps 1) to 3).

13) Thus, disassembly of axle is completed, but UFJ/BJ is unable to be disassembled.

C: INSPECTION

Check the removed parts for damage, wear, corrosion and etc. If faulty, repair or replace.

1) DOJ (Double Offset Joint)

Check seizure, corrosion, damage, wear and excessive play.

2) Shaft

Check excessive bending, twisting, damage and wear.

3) UFJ (Under cut Free Joint)

Check seizure, corrosion, damage and excessive play.

4) Boot

Check for wear, warping, breakage or scratches.

5) Grease

Check for discoloration or fluidity.

D: ASSEMBLY

Use specified grease.

UFJ on BJ side:

Molylex No. 2 (P/N 723223010) or Sunlight TB2-A

DOJ side:

AT model — VU-3A702 (Yellow)

MT model — Molylex No. 2 (P/N 723223010) or Sunlight TB2-A

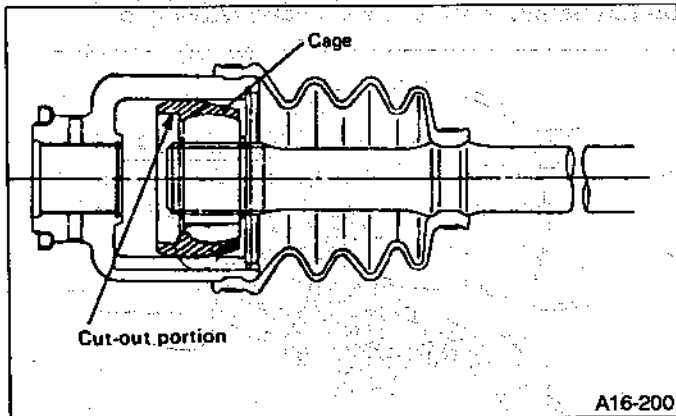
1) Install BJ boot in specified position, and fill it with 60 to 70 g (2.12 to 2.47 oz) of specified grease.

2) Place DOJ boot at the center of shaft.

Be sure to wrap shaft splines with vinyltape to prevent boot from scratches.

3) Insert DOJ cage onto shaft.

Insert the cage with the cut-out side facing the shaft end, since the cage has an orientation.

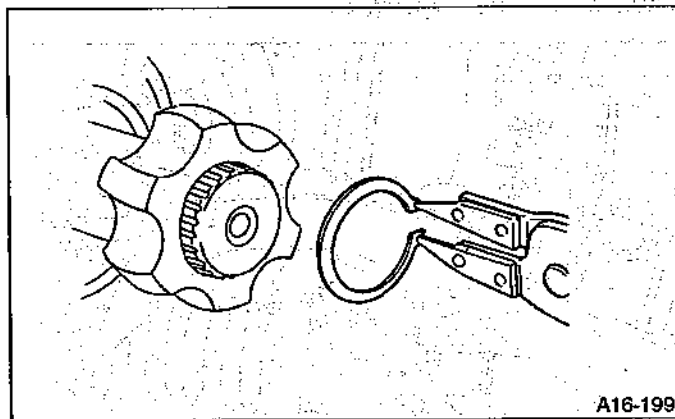


A16-200

Fig. 91

4) Install DOJ inner race on shaft and fit snap ring with special pliers.

Confirm that the snap ring is completely fitted in the shaft groove.

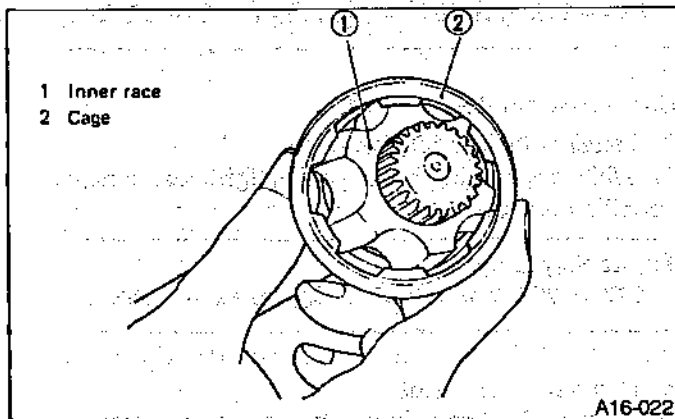


A16-199

Fig. 92

5) Install cage, which was previously fitted, to inner race fixed upon shaft.

Fit the cage with the protruded part aligned with the track on the inner race and then turn by a half pitch.



A16-022

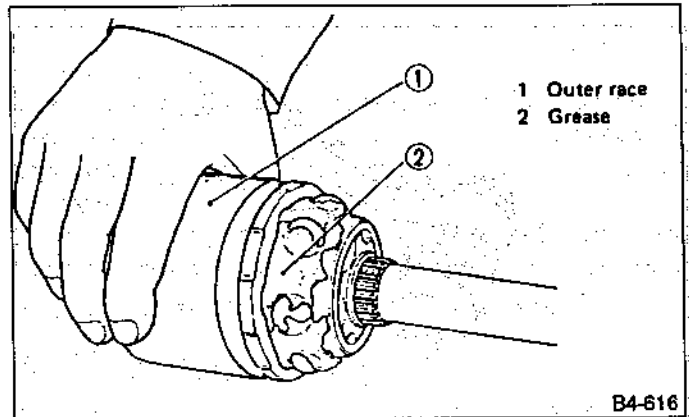
Fig. 93

6) Fill 80 to 90 g (2.82 to 3.17 oz) of specified grease into the interior of DOJ outer race.

7) Apply a coat of specified grease to the cage pocket and six balls.

8) Insert six balls into the cage pocket.

9) Align the outer race track and ball positions and place in the part where shaft, inner race, cage and balls are previously installed, and then fit outer race.



B4-616

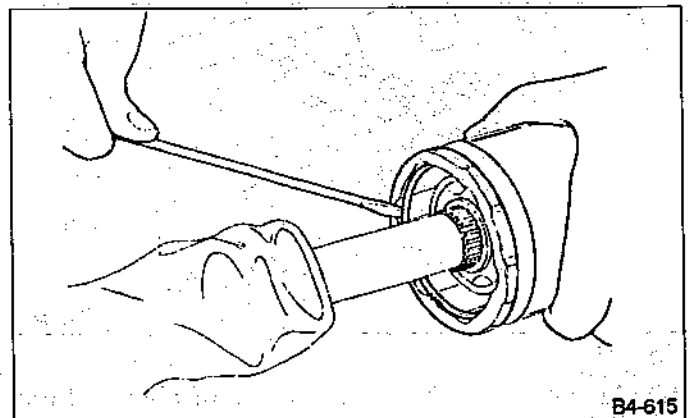
Fig. 94

10) Install circlip in the groove on DOJ outer race.

a. Assure that the balls, cage and inner race are completely fitted in the outer race of DOJ.

b. Exercise care not to place the matched position of circlip in the ball groove of outer race.

c. Pull the shaft lightly and assure that the circlip is completely fitted in the groove.



B4-615

Fig. 95

11) Apply an even coat of the specified grease [20 to 30 g (0.71 to 1.06 oz)] to the entire inner surface of boot. Also apply grease to shaft.

12) Install DOJ boot taking care not to twist it.

a. The inside of the larger end of DOJ boot and the boot groove shall be cleaned so as to be free from grease and other substances.

b. When installing DOJ boot, position outer race of DOJ at center of its travel.

13) Put a band through the clip and wind twice in alignment with band groove of boot.

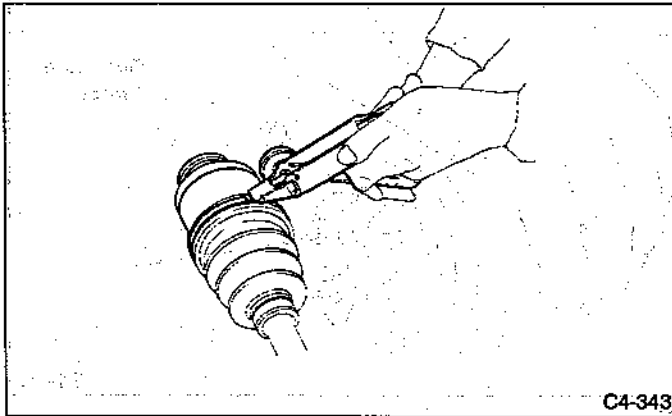
Use a new band.

14) Pinch the end of band with pliers. Hold the clip and tighten securely.

When tightening boot, exercise care so that the air within the boot is appropriate.

15) Tighten band by using **BAND TIGHTENING TOOL** (925091000).

- a. Tighten band until it cannot be moved by hand.
- b. Former **BAND TIGHTENING TOOL** (925090000) is interchangeable with this 925091000.

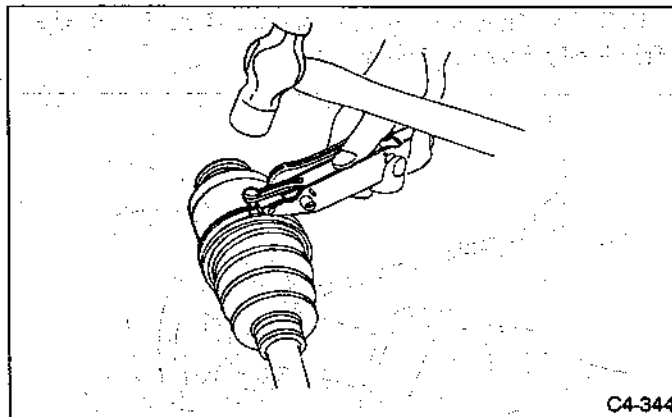


C4-343

Fig. 96

16) Tap on the clip with the punch provided at the end of **BAND TIGHTENING TOOL**.

Tap to an extent that the boot underneath is not damaged.



C4-344

Fig. 97

17) Cut off band with an allowance of about 10 mm (0.39 in) left from the clip and bend this allowance over the clip.

Be careful so that the end of the band is in close contact with clip.

18) Fix up boot on BJ in the same manner.

19) Install protector onto BJ boot band. (For rear side only)

Extend and retract DOJ to provide equal grease coating.

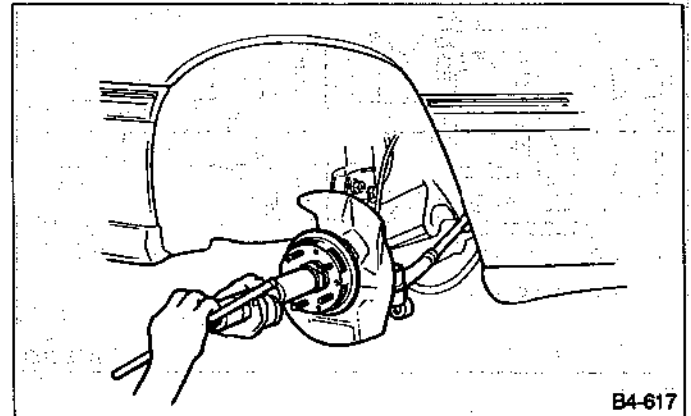
E: INSTALLATION

1. FRONT DRIVE SHAFT

1) Insert UFJ (Under cut free joint) into hub splines. Be careful not to damage inner oil seal lip.

2) Using **AXLE SHAFT INSTALLER** (922431000) and **ADAPTER** (927390000), pull drive shaft into place.

Do not hammer drive shaft when installing it.



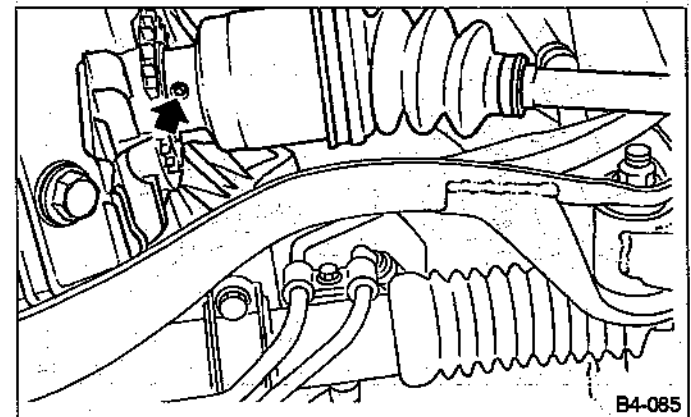
B4-617

Fig. 98

3) Tighten axle nut temporarily.

4) Install DOJ on transmission spindle and drive spring pin into place.

Always use a new spring pin.



B4-085

Fig. 99

5) Install transverse link on front crossmember, and tighten self-locking nut.

Torque (self-locking nut):

83 — 113 N·m (8.5 — 11.5 kg-m, 61 — 83 ft·lb)

Use a new self-locking nut.

6) Install stabilizer bracket.

7) While depressing brake pedal, tighten axle nut to the specified torque.

Tightening torque:

167 — 206 N·m (17 — 21 kg-m, 123 — 152 ft·lb)

a. Use a new axle nut.

b. Always tighten axle nut before installing wheel on vehicle. If wheel is installed and comes in contact with ground when axle nut is loose, wheel bearings may be damaged.

c. Be sure to tighten axle nut to specified torque. Do not overtighten it as this may damage wheel bearing.

8) After tightening axle nut, lock it securely.

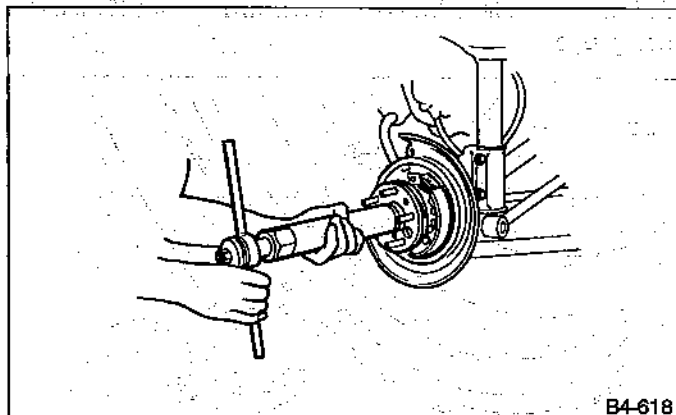
2. REAR DRIVE SHAFT

1) Insert BJ into rear housing splines.

Be careful not to damage inner oil seal lip.

2) Using AXLE SHAFT INSTALLER (922431000) and ADAPTER (927390000), pull drive shaft into place.

Do not hammer drive shaft when installing it.



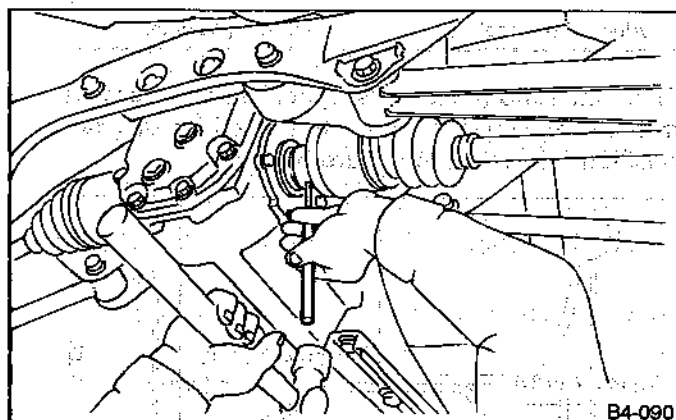
B4-618

Fig. 100

3) Tighten axle nut temporarily.

4) Install DOJ on rear differential spindle and drive spring pin into place.

Always used a new spring pin.



B4-090

Fig. 101

5) Connect rear housing ASSY to trailing link ASSY, and tighten self-locking nut.

Tightening torque:

98 — 127 N•m (10 — 13 kg-m, 72 — 94 ft-lb)

6) Connect rear housing ASSY to lateral link ASSY, and tighten self-locking nut.

Tightening torque:

118 — 157 N•m (12.0 — 16.0 kg-m, 87 — 116 ft-lb)

7) Install stabilizer bracket.

8) While depressing brake pedal, tighten axle nut using a socket wrench.

Tightening torque:

167 — 206 N•m (17 — 21 kg-m, 123 — 152 ft-lb)

a. Use a new axle nut.

b. Always tighten axle nut before installing wheel on vehicle. If wheel is installed and comes in contact with ground when axle nut is loose, wheel bearings may be damaged.

c. Be sure to tighten axle nut to specified torque. Do not overtighten it as this may damage wheel bearing.

9) After tightening axle nut, lock it securely.

5. Half Wheel Cap

See "SPECIFICATIONS AND SERVICE DATA" for:

- Combination of tire and wheel
- Tire inflation pressure

A: REMOVAL

Pry off the half cap with a wheel cap remover inserted into openings in the cap.

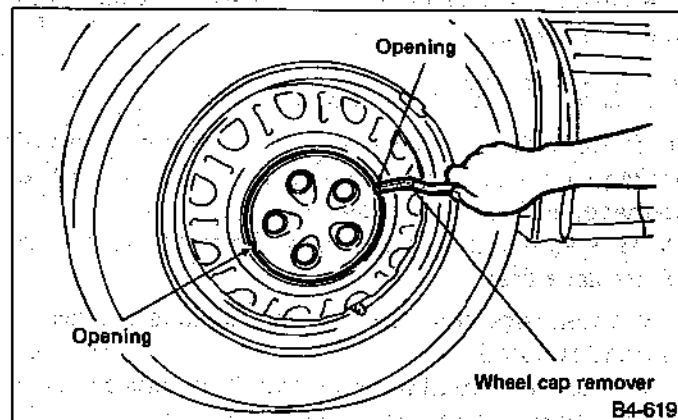


Fig. 102

B: INSTALLATION

Attach the half cap to the disc wheel by tapping it with the palm of your hand.

8. Aluminum Wheel

A: INSPECTION

Inspection for aluminum wheels is basically the same as the one for steel wheels. However, check the rim flange for cracks or damage, and replace (not repair) aluminum wheel if air leakage is found.

B: PRECAUTIONS

Aluminum wheels are easily scratched. To maintain their appearance and safety, observe the following:

- 1) Do not damage aluminum wheels during removal, disassembly, installation, wheel balancing, etc. After removing aluminum wheels, place them on a rubber mat, etc.
- 2) While vehicle is being driven, be careful not to ride over sharp obstacles or allow aluminum wheels to contact the shoulder of the road.
- 3) When installing tire chain, be sure to install it properly not to have a slack; otherwise it may hit wheel while driving.
- 4) When washing aluminum wheel, use neutral synthetic detergent and water. Avoid using the cleanser including abrasive, hard brushes or an automatic car washer.

9. Wheel Balancing

- 1) Proper wheel balance may be lost if the tire is repaired or if it wears. Check the tire for dynamic balance, and repair as necessary.
- 2) To check for dynamic balance, use a dynamic balancer. Drive in the balance weight on both the top and rear sides of the rim.
- 3) Some types of balancer can cause damage to the wheel. Use an appropriate balancer when adjusting the wheel balance.
- 4) Use genuine balance weights.

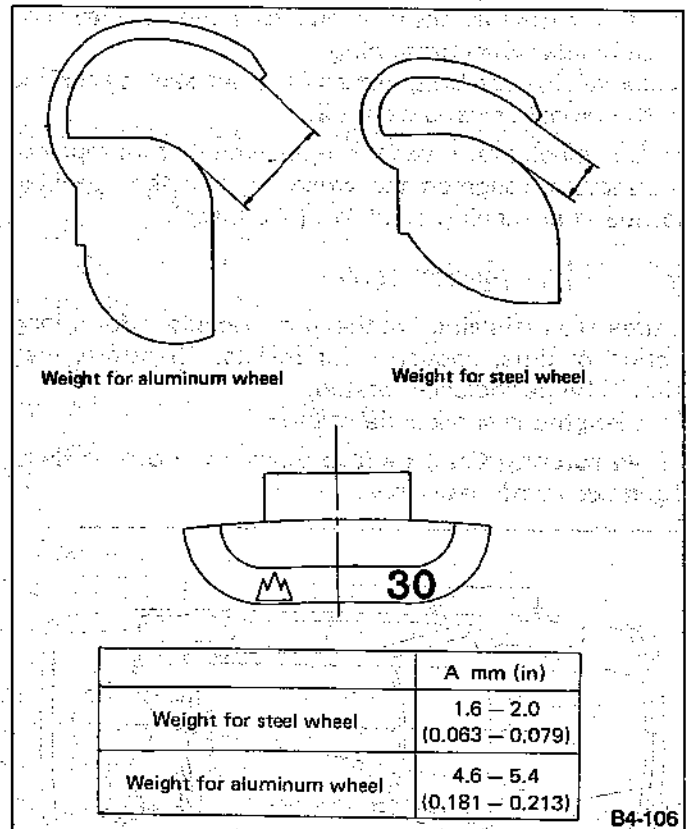


Fig. 107

- a. All balance weights shown in Table are colored silver.
- b. 55 g (1.94 oz) weight used with aluminum wheel is not available.
- c. Balance weights are available for use with any of 13- to 15-inch wheels.

10. Installation of Wheel Assembly to Vehicle

- 1) Attach the wheel to the hub by aligning the wheel bolt hole with the hub bolt.
- 2) Temporarily attach the wheel nuts to the hub bolts. (In the case of aluminum wheel, use SUBARU genuine wheel nut for aluminum wheel.)
- 3) Manually tighten the nuts making sure the wheel hub hole is aligned correctly to the guide portion of hub.
- 4) Tighten the wheel nuts in a diagonal selection to the specified torque. Use a wheel nut wrench.

Wheel nut tightening torque:

78 — 98 N·m (8 — 10 kg·m, 58 — 72 ft·lb)

- a. Tighten the wheel nuts in two or three steps by gradually increasing the torque and working diagonally, until the specified torque is reached. For drum brake models, excess tightening of wheel nuts may cause wheels to "judder".

b. Do not depress the wrench with a foot; Always use both hands when tightening.

c. Make sure the bolt, nut and the nut seating surface of the wheel are free from oils.

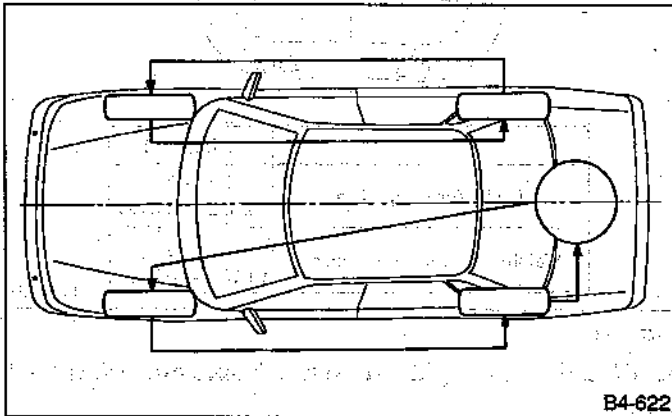
5) If a wheel is removed for replacement or for repair of a puncture, retighten the wheel nuts to the specified torque after running 1,000 km (600 miles).

11. Tire Rotation

If tires are maintained at the same positions for a long period of time, uneven wear results. Therefore, they should be periodically rotated.

This lengthens service life of tires.

When rotating tires, replace unevenly worn or damaged tires with new ones.



B4-622

Fig. 108

[Faint, illegible text, likely bleed-through from the reverse side of the page]

[Faint, illegible text, likely bleed-through from the reverse side of the page]

STEERING SYSTEM

SUBARU®

1992

SERVICE MANUAL

	Page
M. MECHANISM AND FUNCTION	2
1. Tilt Steering Column	2
2. VGR (Variable Gear Ratio) Gearbox	4
3. Power Steering System	5
S SPECIFICATIONS AND SERVICE DATA	11
C COMPONENT PARTS	13
1. Steering Wheel & Column (Rigid)	13
2. Steering Wheel & Column (Tilt)	14
3. Gearbox	15
4. Oil Pump & Tank	16
5. Power Steering Oil Pump	17
W SERVICE PROCEDURE	18
1. Steering Column (Rigid)	18
2. Tilt Steering Column	21
3. Steering Gearbox (Power Steering System)	24
4. Control Valve (Power Steering Gearbox)	34
5. Hose ASSY (Power Steering System)	43
6. Oil Pump (Power Steering System)	45
T TROUBLESHOOTING	53
1. Power Steering	53



M MECHANISM AND FUNCTION

1. Tilt Steering Column

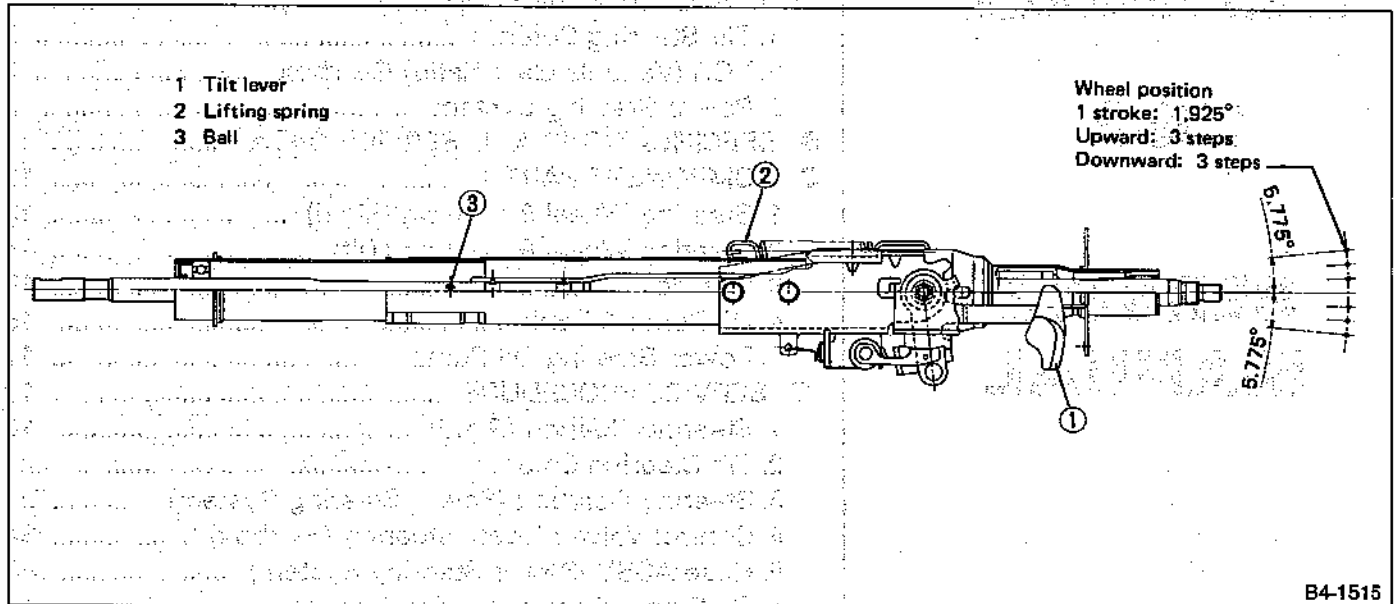


Fig. 1

B4-1515

A: FEATURE

1. TILT STEERING COLUMN

The tilt position is determined by engagement of the movable gear and stationary gear.

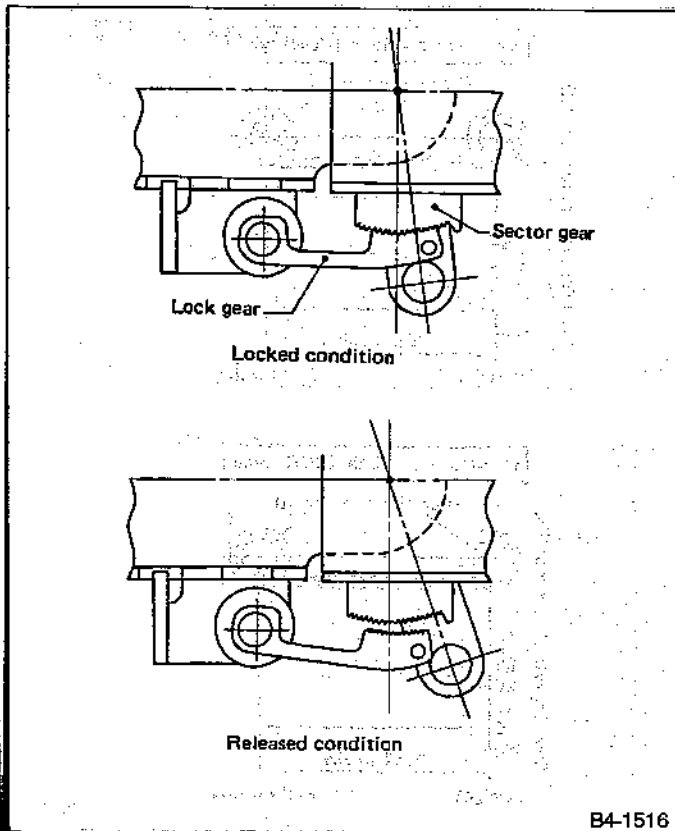
2. IMBEDDED BALL TYPE ENERGY-ABSORBING MECHANISM

- 1) Construction of the steering column is simplified to reduce weight since energy absorption is no longer required for the steering column.
- 2) The energy-absorbing characteristic is regulated by imbedded ball height.

B: OPERATION

1. TILT STEERING COLUMN

- 1) When the tilt lever is turned upward, the lock gear is disengaged from the sector gear. This causes the coil spring to tilt the steering column up.
- 2) With tilt lever turned upward, adjust steering wheel position.
- 3) Tilt lever has 7 adjustable positions — 3 position each upward and downward from Neutral.

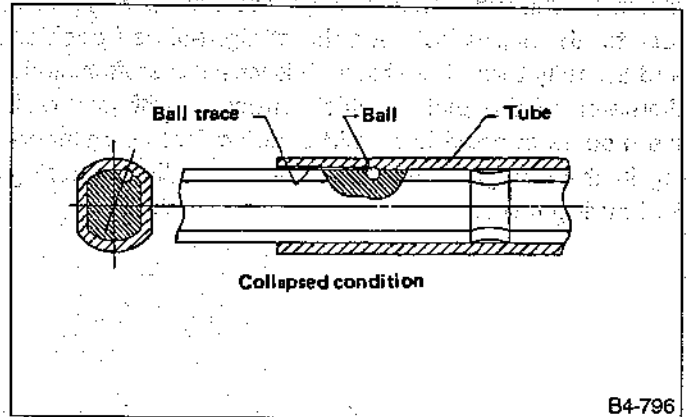


B4-1516

Fig. 2

2. IMBEDDED BALL TYPE ENERGY-ABSORBING MECHANISM

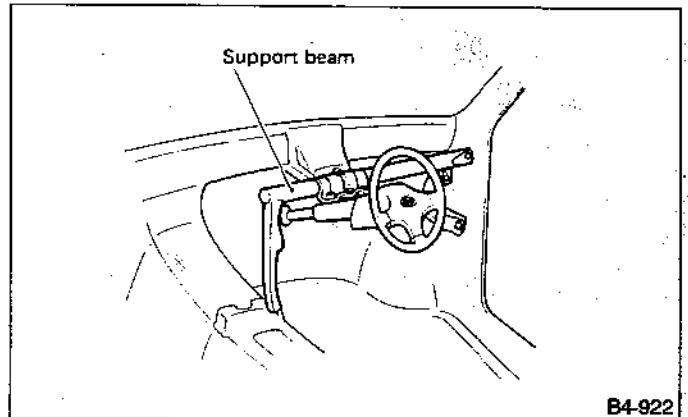
1) The protrusion of the ball imbedded in the steering shaft provides plastic deformation of the cube's inner wall to effectively absorb energy encountered.



B4-796

Fig. 3

• The steering column is held by a support beam located close to the steering wheel to reduce the overhang. The upper bearing is also located close to the steering wheel to increase supporting rigidity, as well as to reduce the problem of a shaking or shimmying wheel.



B4-922

Fig. 4

3. Power Steering System

1. HYDRAULIC SYSTEM

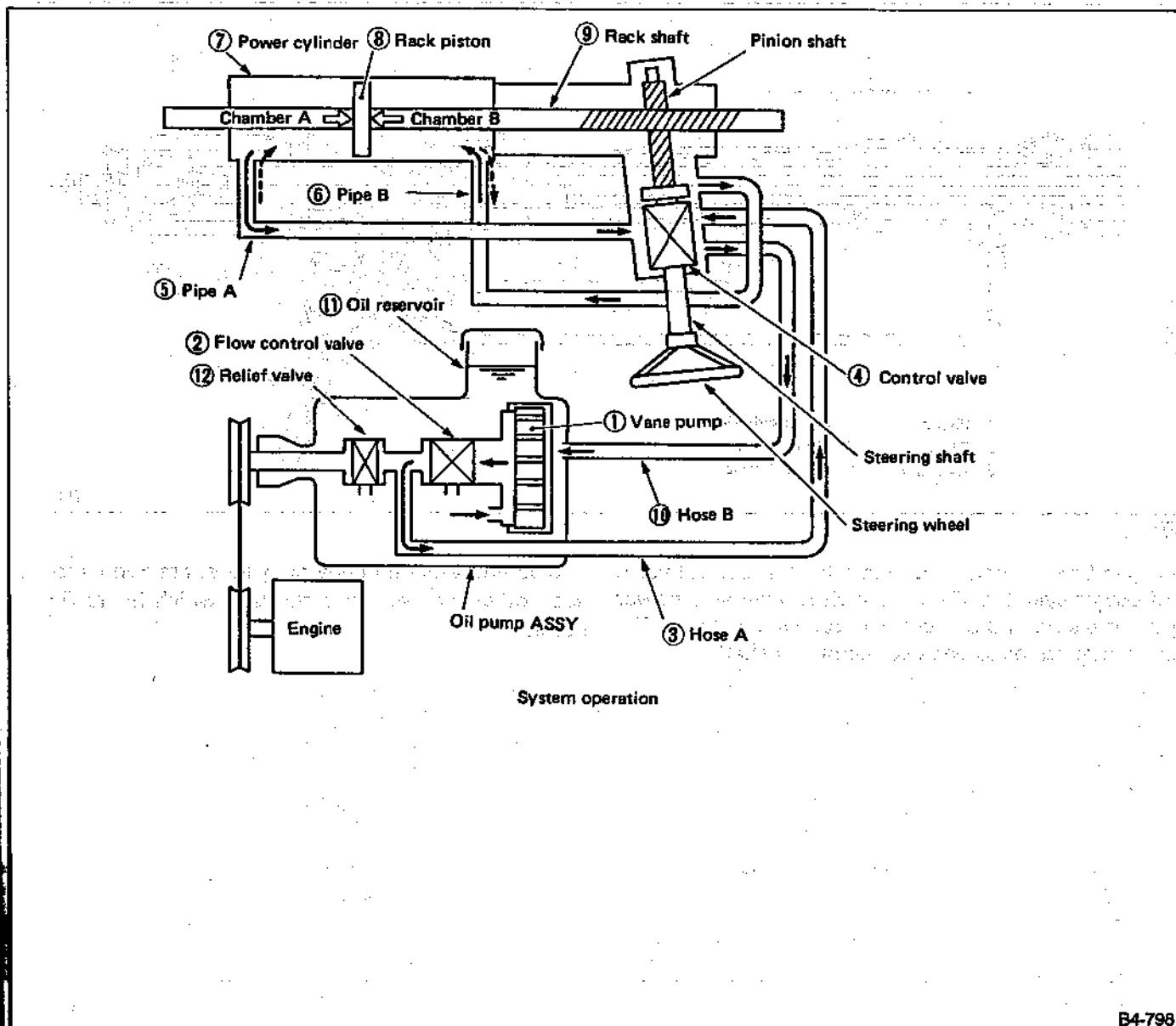


Fig. 6

- 1) Vane pump ① is belt-driven from the engine to discharge oil under pressure.
- 2) Oil under pressure is controlled by the flow control valve ② located inside the oil pump ASSY in response to engine speed and is delivered to control valve ④ via hose A ③.
- 3) When the steering wheel is turned, control valve ④ connected to the pinion shaft activates to form an oil flow circuit corresponding to the rotation direction of the steering wheel. Oil will then be delivered to chamber A or B via pipe A ⑤ or B ⑥.
- 4) Oil in chamber A or B acts on rack pinion ⑧ to produce the force required to move rack shaft ⑨ to the

left or the right. This helps reduce the effort required to operate the steering wheel.

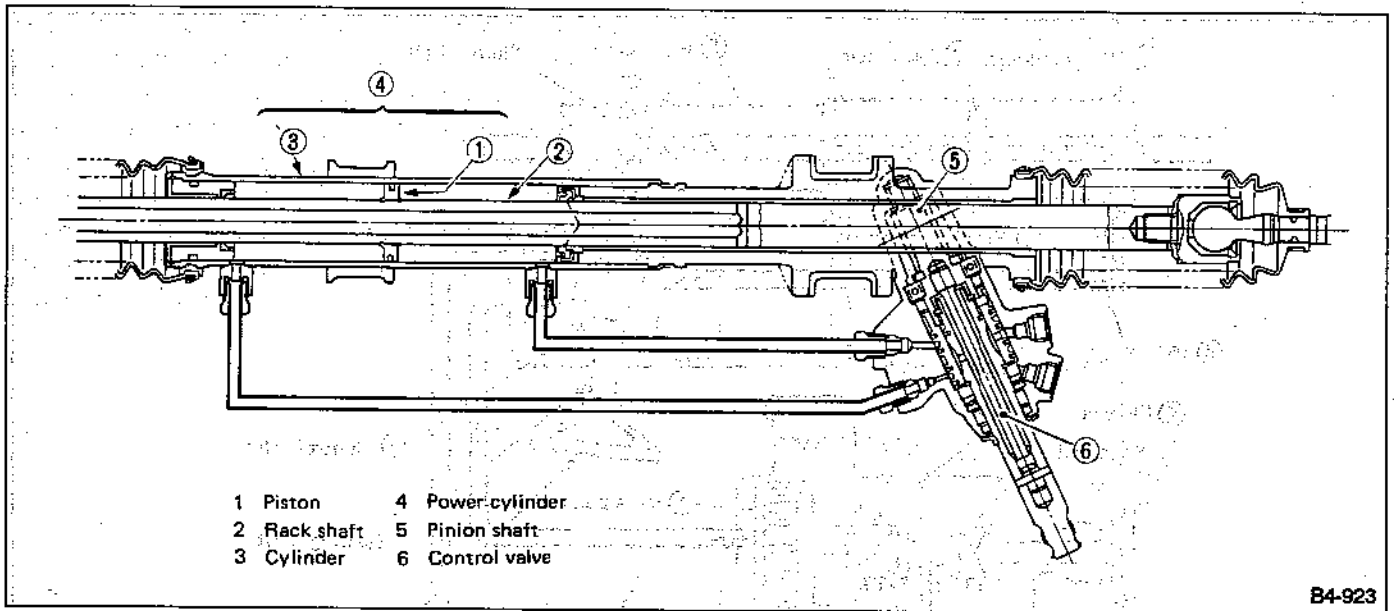
- 5) Movement of rack piston ⑧ in turn causes oil in the other chamber to return to oil reservoir ⑪ via pipe A ⑤ or B ⑥, control valve ④ and hose B ⑩.

- If the hydraulic system becomes inoperative, the steering shaft will then be connected to the pinion shaft mechanically via control valve ④. Thus, the steering shaft can act as one similar to a manual steering system to move the rack and pinion.

- To control the maximum oil pressure setting, relief valve ⑫ is built into flow control valve ② of the oil pump ASSY to release excess oil pressure.

2. GEARBOX ASSY

1) Power cylinder



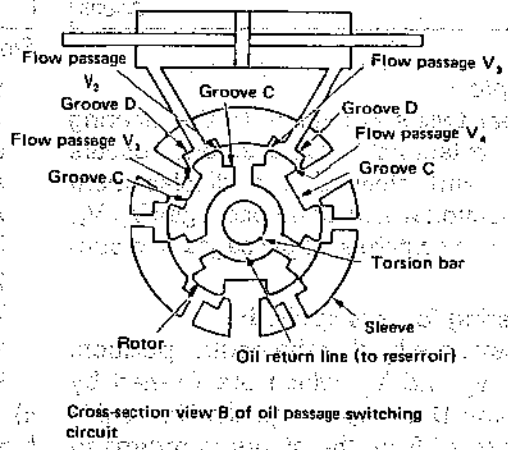
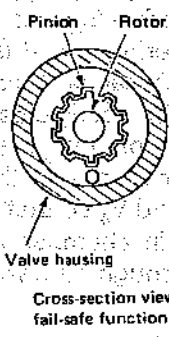
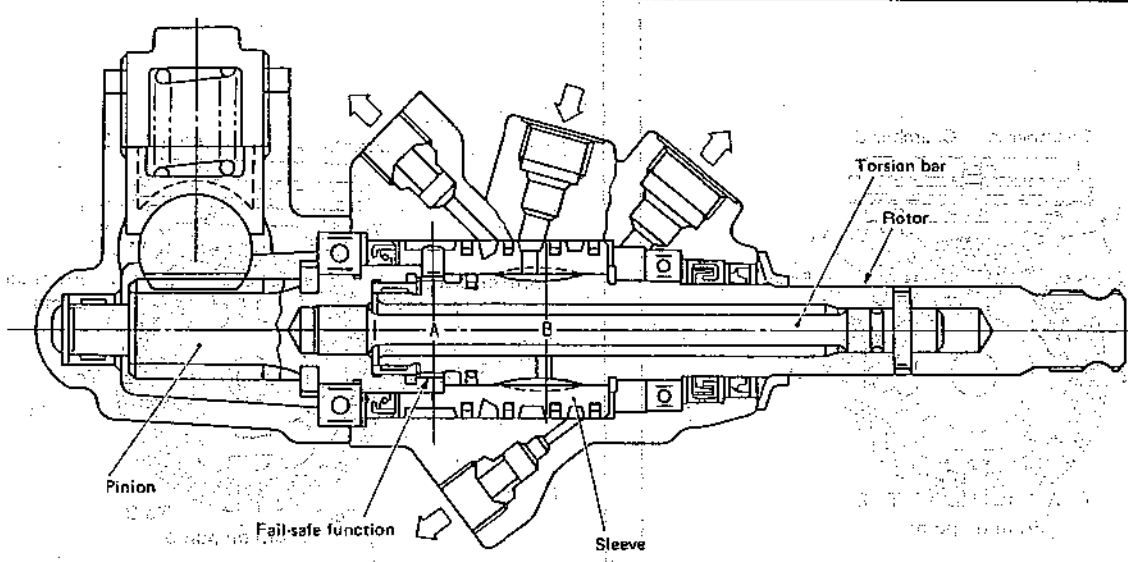
B4-923

Fig. 7

The gearbox is integrated with a built-in control valve and power cylinder. The rack shaft is used as a power cylinder piston and a rotary control valve is located in such a manner as to enclose the pinion shaft.

The control valve and power cylinder are connected to each other by two pipes through which hydraulic oil flows.

2) Control valve



B4-924

Fig. 8 The control valve consists of a rotor (which rotates together with the steering shaft), a pinion (which is connected to the rotor and torsion bar), and a sleeve (which rotates together with the pinion). Oil grooves C and D are located in the rotor and sleeve to form oil flow passages V₁ through V₄. The pinion and rotor are meshed with adequate clearance. They utilize a fail-safe design.

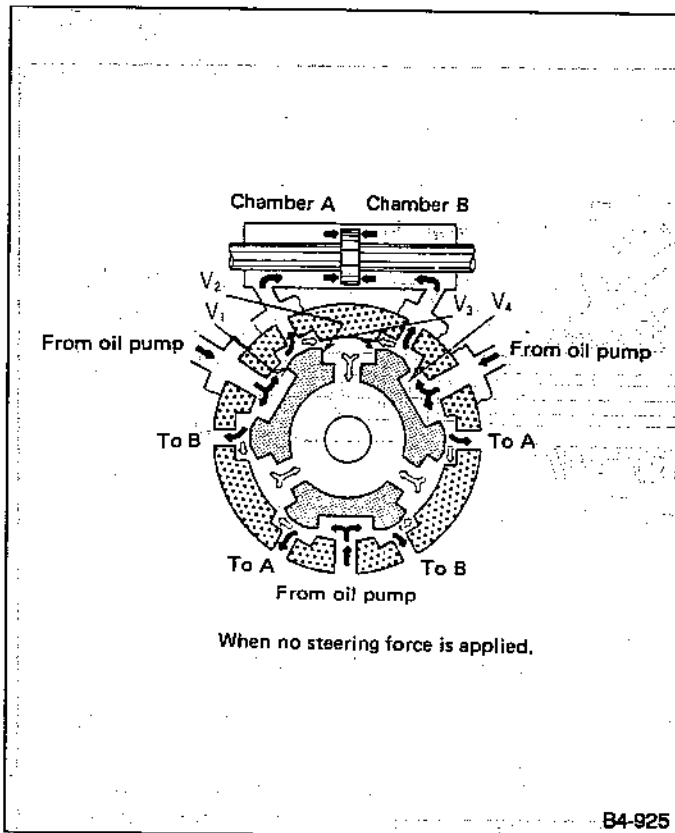


Fig. 9

3) Operating principle

When the torsion bar twists in relation to the steering force, a relative rotational displacement occurs between the rotor and sleeve. This displacement changes the cross-sectional area of oil passages V_1 , V_2 , V_3 and V_4 , which in turn switches oil passages and controls oil pressure.

(1) When no steering force is applied:

The rotor and sleeve are held at the neutral position. Oil passages V_1 , V_2 and V_3 , which are formed by valve grooves C and D are open equally. Under this condition, oil delivered from the oil pump returns to the oil reservoir so that neither oil pressure builds up nor does the power cylinder activate.

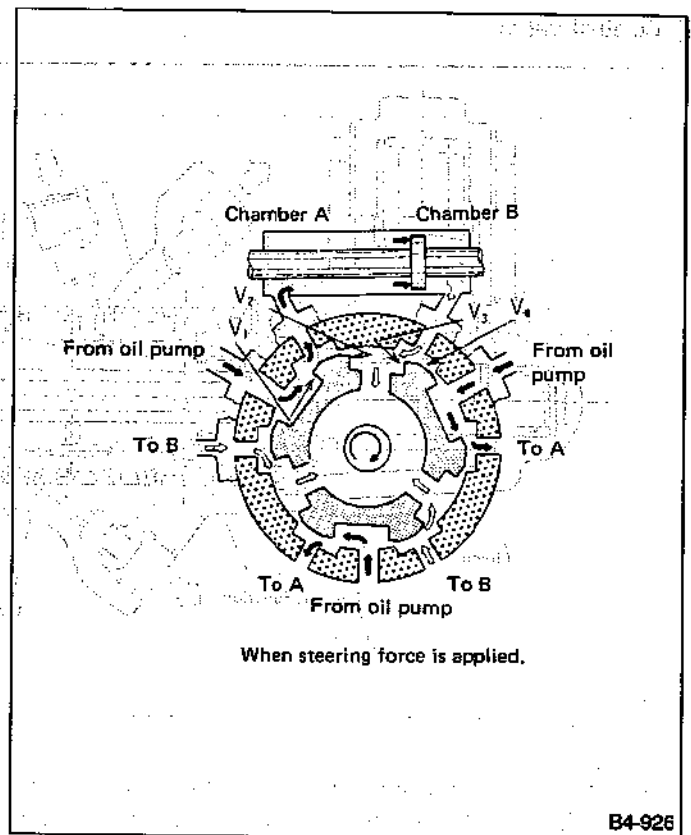


Fig. 10

(2) When steering force is applied:

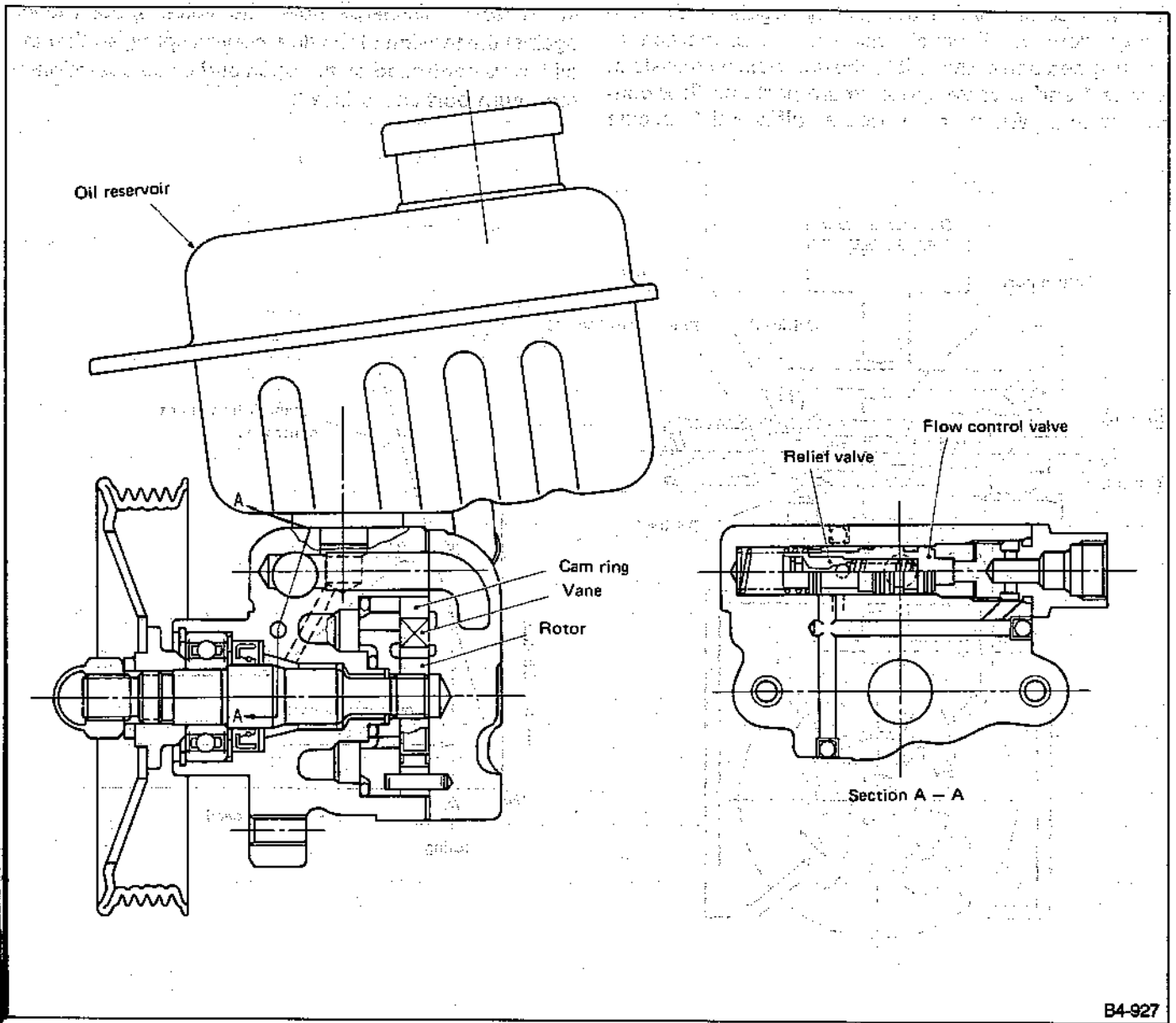
When the steering wheel is turned to the right, for example, oil passages V_1 and V_2 open while oil passages V_3 and V_4 nearly close.

At this point, oil under pressure in chamber A increases in response to the throttle position of oil passages V_2 and V_4 so that the rack piston moves to the right. Oil in chamber B, on the other hand, is discharged through oil passage V_3 , returning to the oil reservoir.

4) Fail-safe function

If oil pressure fails to build up due to a broken oil pump drive belt, torque is transmitted from the valve rotor to the pinion by way of the fail-safe function.

3. OIL PUMP & TANK



B4-927

Fig. 11

The oil pump is belt-driven from the engine. The oil flow is controlled in response to engine speed so that an adequately "heavy" steering effort is maintained during high-speed operation.

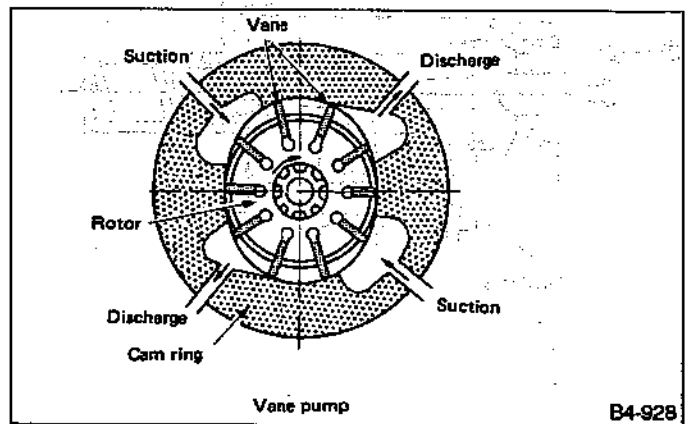
The oil pump is a vane type. It is integrated with an oil reservoir and houses the flow control and relief-valves.

1) Vane pump

The vane pump consists of a rotor, cam rings, and ten vanes.

When the rotor rotates, the vane located in each groove of the rotor is radially swung out by centrifugal force and pressed against the cam ring. The tip of the vane slides along the inner oval wall of the cam ring so that oil is delivered to the chamber formed by the rotor, cam ring and vane by way of a pea-shaped groove. Oil from the chamber is discharged into the oil circuit via the

discharge port.



B4-928

Fig. 12

2) Flow control valve

The flow control valve adequately regulates the discharge flow of oil which increases in proportion to pump speed and delivers it to the gearbox. It consists of orifices 1 and 2, valve spool, return port and flow control spring. When a pressure differential occurs

between the front and rear of orifice 2 in response to increases in discharge flow, the valve spool moves against the tension of the flow control spring so that the oil flow is controlled by the open and close operation of the return port and orifice 3.

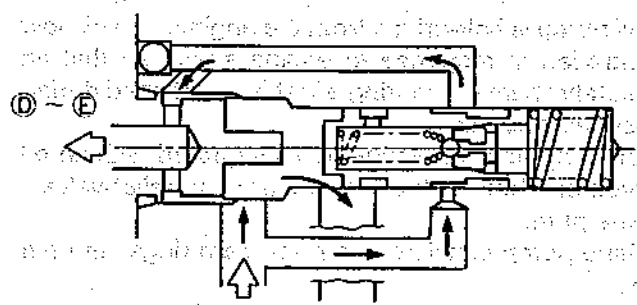
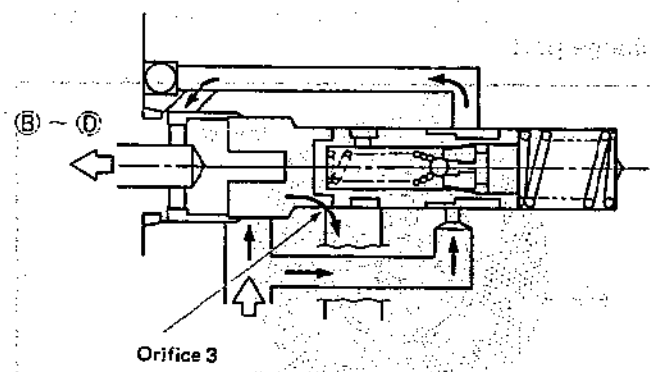
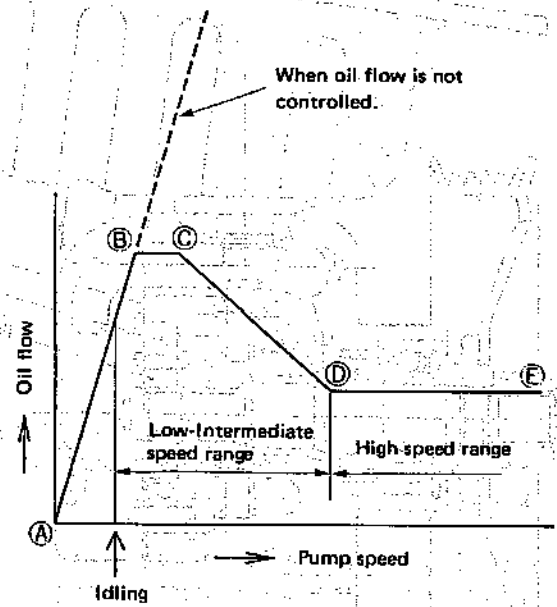
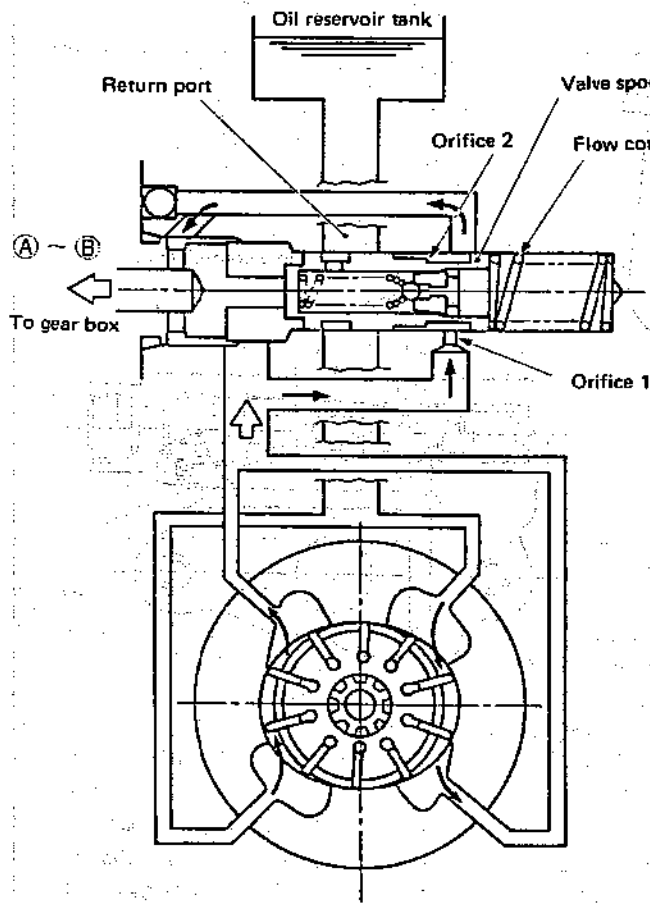


Fig. 13

B4-929

S SPECIFICATIONS AND SERVICE DATA

A: SPECIFICATIONS

Whole system	Minimum turning radius	m (ft)	Non-TURBO: 5.1 (16.7) TURBO: 5.3 (17.4)
	Steering angle (Inside-Outside)		Non-TURBO: 39° — 33.5° TURBO: 36.5° — 32.0°
	Steering wheel diameter	mm (in)	385 (15.16)
	Overall gear ratio (Turns, lock to lock)	Manual steering Power steering	20 — 25 (4.5) 16.0 (3.3)
Gearbox	Type		Rack and pinion, Integral
	Backlash		0 (Automatically adjustable)
	Valve (Power steering system)		Rotary valve
Pump (Power steering system)	Type		Vane pump
	Oil tank		Installed on pump
	Output	cm ³ (cu in)/rev.	7.2 (0.439)
	Relief pressure	kPa (kg/cm ² , psi)	1600-1800 cc 6,375 (65, 924) TURBO: 2000-2200 cc 7,355 (75, 1,067)
	Hydraulic fluid control		Dropping in response to increased engine revolutions
	Hydraulic fluid	ℓ (US qt, Imp qt)	1,000 rpm: 7 (7.4, 6.2) 3,000 rpm: 3.5 (3.7, 3.1)
	Range of revolution	rpm	500 — 7,500
Working Fluid (Power steering system)	Revolving direction		Clockwise
	Name		ATF DEXRON II
	Capacity	ℓ (US qt, Imp qt)	Oil tank : 0.3 (0.3, 0.3) Total : 0.7 (0.7, 0.6)

B: SERVICE DATA

	ITEM	STANDARD	SERVICE LIMIT
Steering wheel	Free play mm (in)	17 (0.67)	
Turning angle	Inner tire & wheel	Non-TURBO: 39°	
	Outer tire & wheel	TURBO: 36.5°	
Steering shaft	Clearance between steering wheel and column cover mm (in)	3.0 (0.118)	
	Rack shaft Pinion	Bend limit (Run-out) Free play limit Rotating torque	0.2 mm (0.008 in) 0.3 mm (0.012 in) Within 30 mm (1.18 in) from rack center at straight ahead position: Less than 0.9 N·m (0.09 kg-m, 0.7 ft-lb) Maximum allowable value: 1.4 N·m (0.14 kg-m, 1.0 ft-lb)
Steering gearbox (Manual steering system)	Sliding resistance N (kg, lb)	240.3 (24.5, 54.0) or less	
	Rack shaft play in radial direction Right-turn steering Left-turn steering	mm (in)	0.15 (0.0059) or less Horizontal movement: 0.3 (0.012) or less Vertical movement: 0.15 (0.0059) or less
	Input shaft play In radial direction In axial direction	mm (in)	0.18 (0.0071) or less 0.1 (0.004) or less
	Turning resistance N (kg, lb)	Within 30 mm (1.18 in) from rack center in straight ahead position: Less than 11.18 (1.14, 2.51) Maximum allowable value: 12.7 (1.3, 2.9)	
	Pulley shaft Radial play Axial play	mm (in)	0.4 (0.016) or less 0.9 (0.035) or less
Oil pump (Power steering system)	Pulley Ditch deflection Resistance to rotation	mm (in) N (kg, lb)	1.0 (0.039) or less 9.22 (0.94, 2.07) or less
	Regular pressure kPa (kg/cm ² , psi)	981 (10, 142) or less	
	Relief pressure kPa (kg/cm ² , psi)	7,355 — 7,846 (75 — 80, 1,067 — 1,138)	
	Steering wheel effort (Power steering system)	At standstill with engine idling on a concrete road N (kg, lb)	31.4 (3.2, 7.1) or less
	At standstill with engine stalled on a concrete road N (kg, lb)	147 (15, 33) or less	

C: RECOMMENDED POWER STEERING FLUID

Recommended power steering fluid	Manufacturer
ATF DEXRON II	B.P.
	CALTEX
	CASTROL
	MOBIL
	SHELL
	TEXACO

2. Steering Wheel & Column (Tilt)

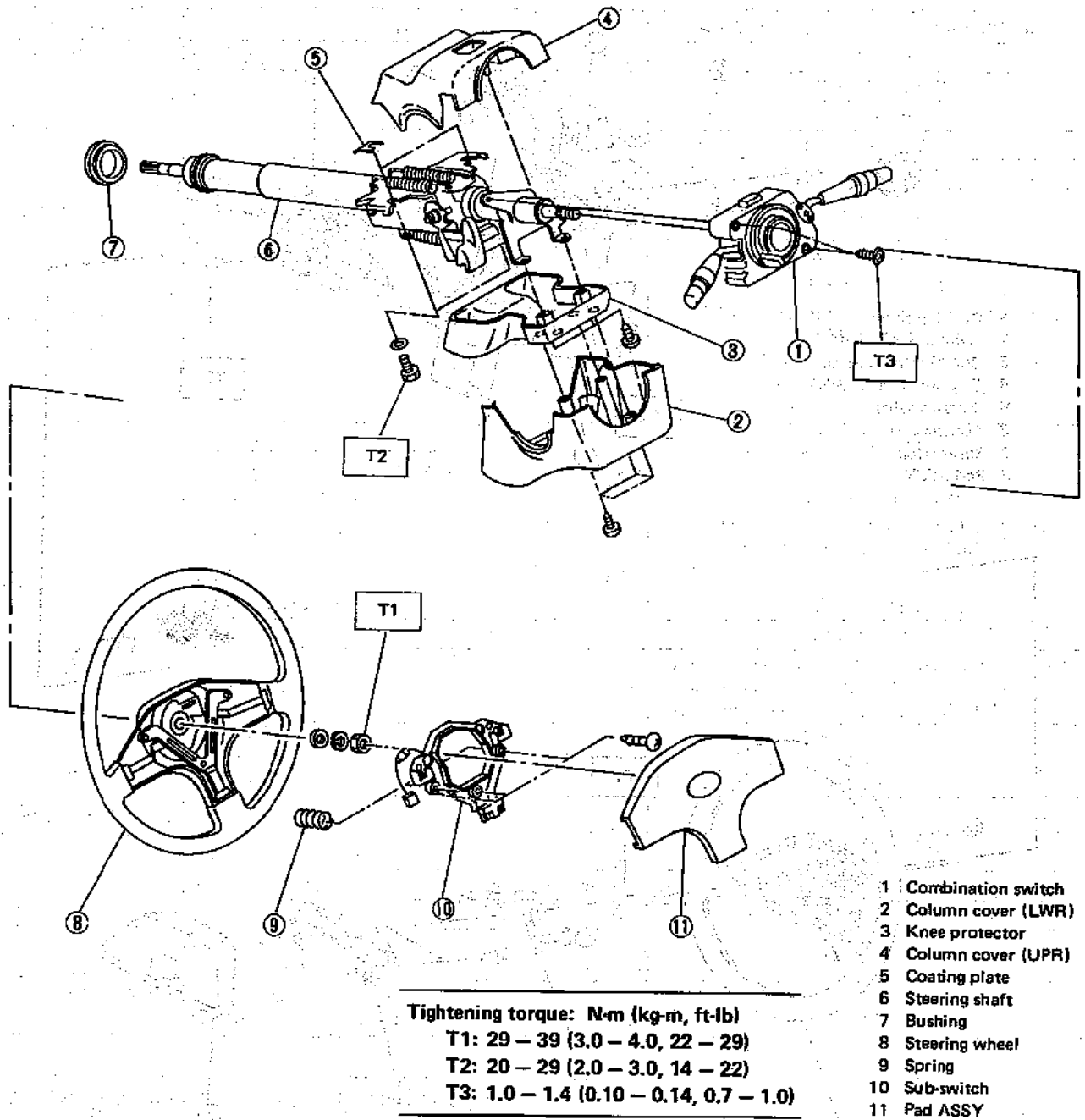
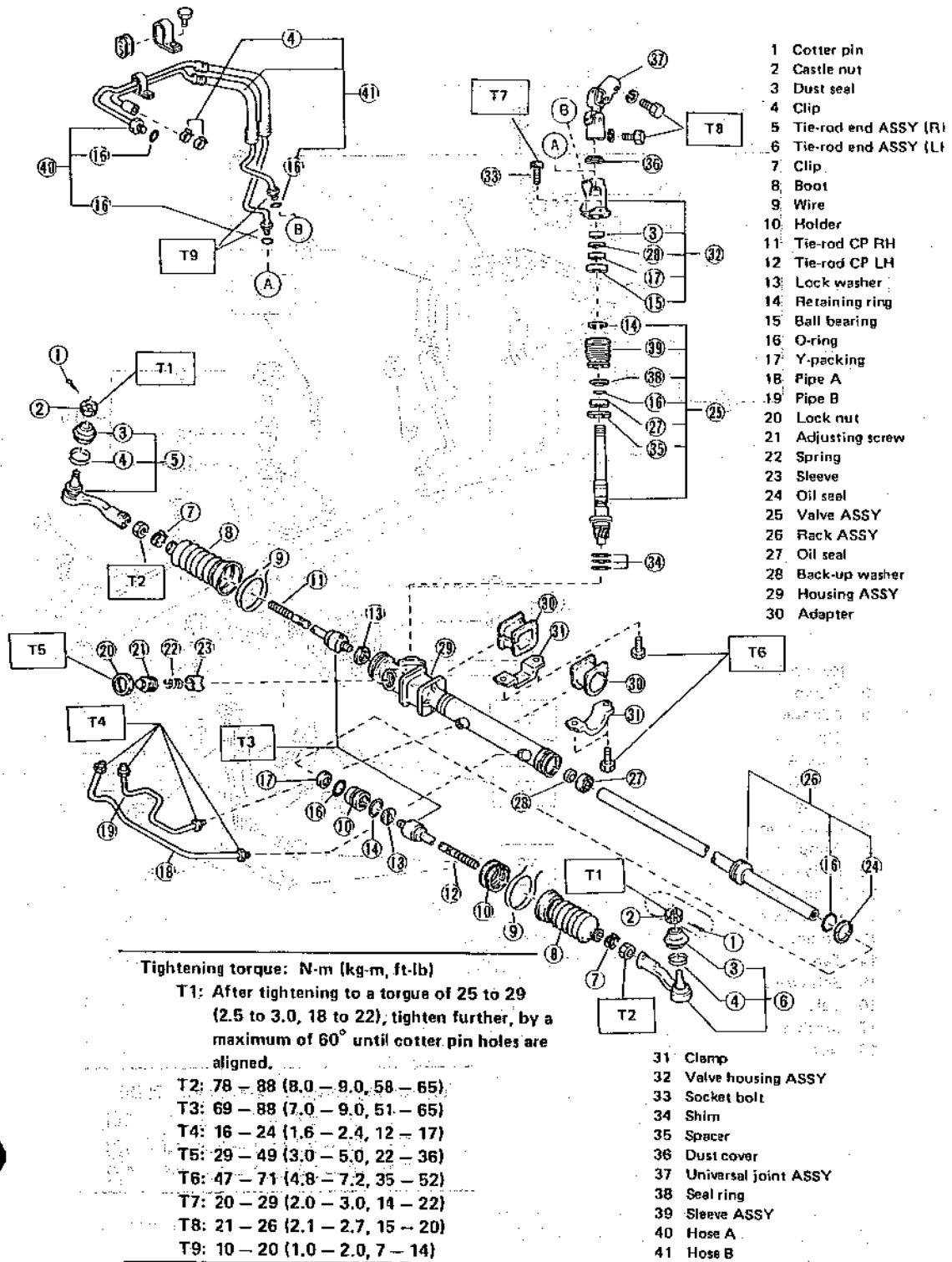


Fig. 15

B4-1517

3. Gearbox



- 1 Cotter pin
- 2 Castle nut
- 3 Dust seal
- 4 Clip
- 5 Tie-rod end ASSY (R)
- 6 Tie-rod end ASSY (L)
- 7 Clip
- 8 Boot
- 9 Wire
- 10 Holder
- 11 Tie-rod CP RH
- 12 Tie-rod CP LH
- 13 Lock washer
- 14 Retaining ring
- 15 Ball bearing
- 16 O-ring
- 17 Y-packing
- 18 Pipe A
- 19 Pipe B
- 20 Lock nut
- 21 Adjusting screw
- 22 Spring
- 23 Sleeve
- 24 Oil seal
- 25 Valve ASSY
- 26 Rack ASSY
- 27 Oil seal
- 28 Back-up washer
- 29 Housing ASSY
- 30 Adapter

Tightening torque: N-m (kg-m, ft-lb)

T1: After tightening to a torque of 25 to 29 (2.5 to 3.0, 18 to 22), tighten further, by a maximum of 60° until cotter pin holes are aligned.

T2: 78 - 88 (8.0 - 9.0, 58 - 65)

T3: 69 - 88 (7.0 - 9.0, 51 - 65)

T4: 16 - 24 (1.6 - 2.4, 12 - 17)

T5: 29 - 49 (3.0 - 5.0, 22 - 36)

T6: 47 - 71 (4.8 - 7.2, 35 - 52)

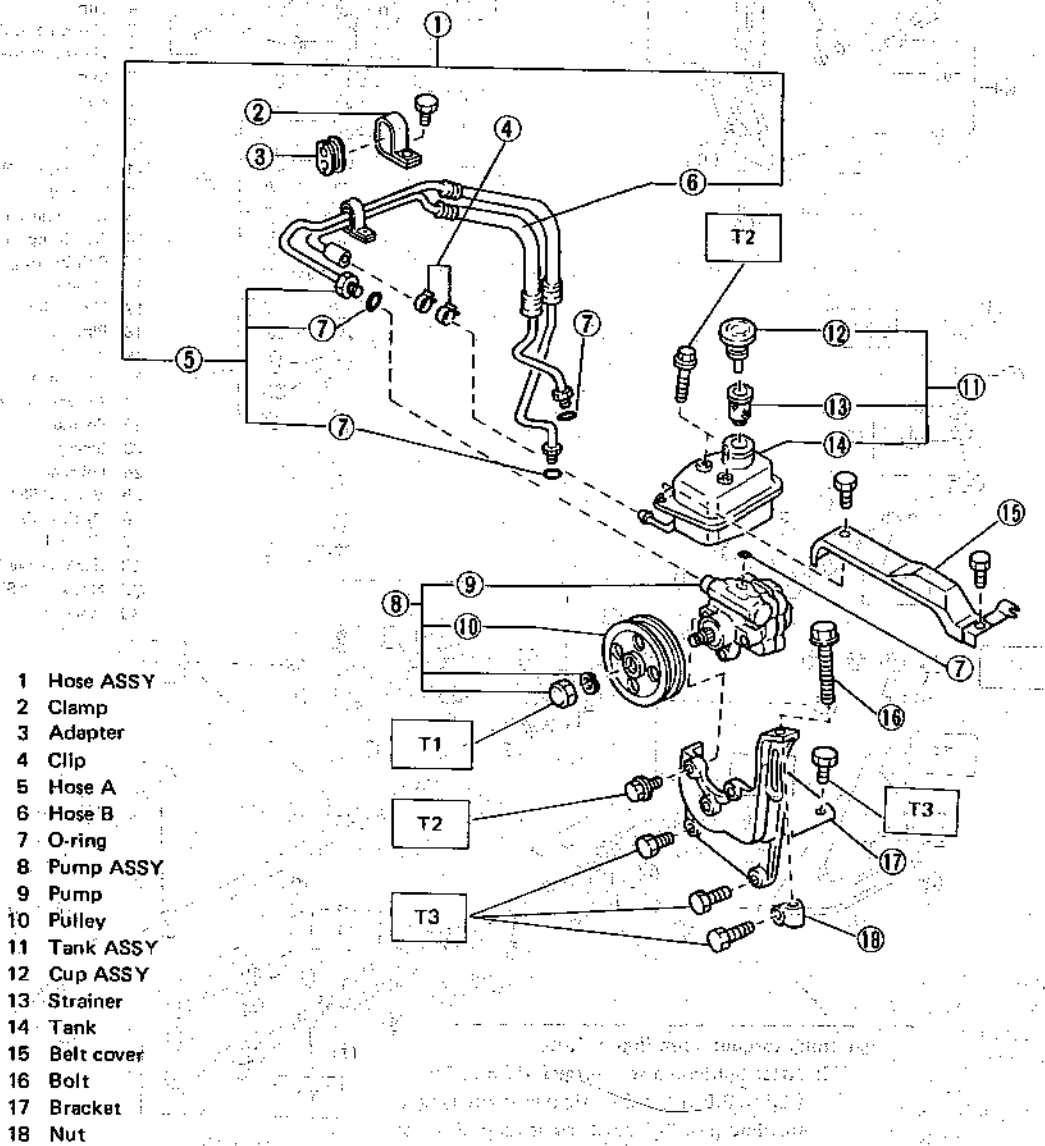
T7: 20 - 29 (2.0 - 3.0, 14 - 22)

T8: 21 - 26 (2.1 - 2.7, 15 - 20)

T9: 10 - 20 (1.0 - 2.0, 7 - 14)

- 31 Clamp
- 32 Valve housing ASSY
- 33 Socket bolt
- 34 Shim
- 35 Spacer
- 36 Dust cover
- 37 Universal joint ASSY
- 38 Seal ring
- 39 Sleeve ASSY
- 40 Hose A
- 41 Hose B

4. Oil Pump & Tank



- 1 Hose ASSY
- 2 Clamp
- 3 Adapter
- 4 Clip
- 5 Hose A
- 6 Hose B
- 7 O-ring
- 8 Pump ASSY
- 9 Pump
- 10 Pulley
- 11 Tank ASSY
- 12 Cup ASSY
- 13 Strainer
- 14 Tank
- 15 Belt cover
- 16 Bolt
- 17 Bracket
- 18 Nut

Tightening torque: N·m (kg·m, ft·lb)

T1:	42 - 62 (4.3 - 6.3, 31 - 46)
T2:	18 - 23 (1.8 - 2.3, 13 - 17)
T3:	20 - 24 (2.0 - 2.4, 14 - 17)

Fig. 17

5. Power Steering Oil Pump

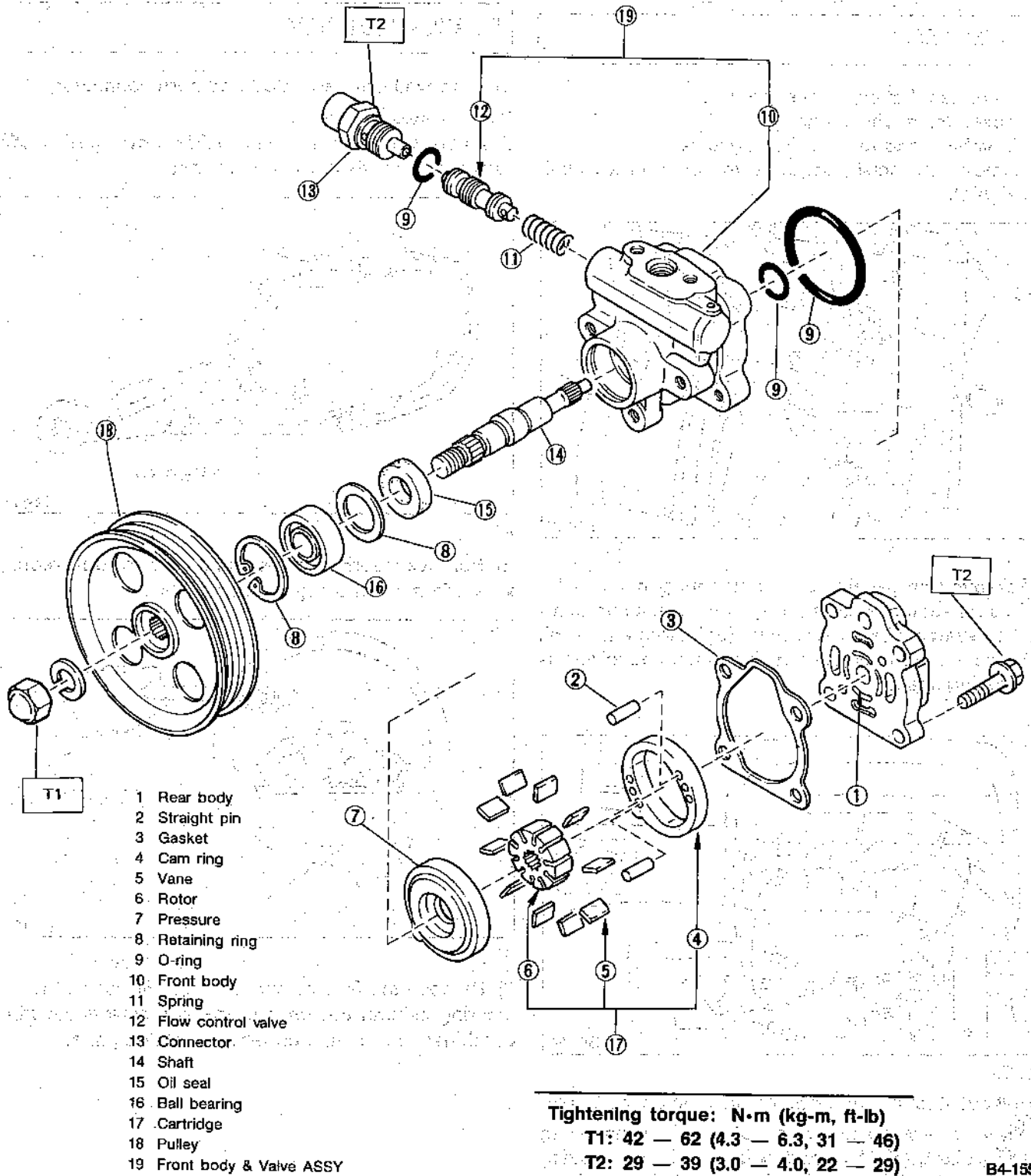
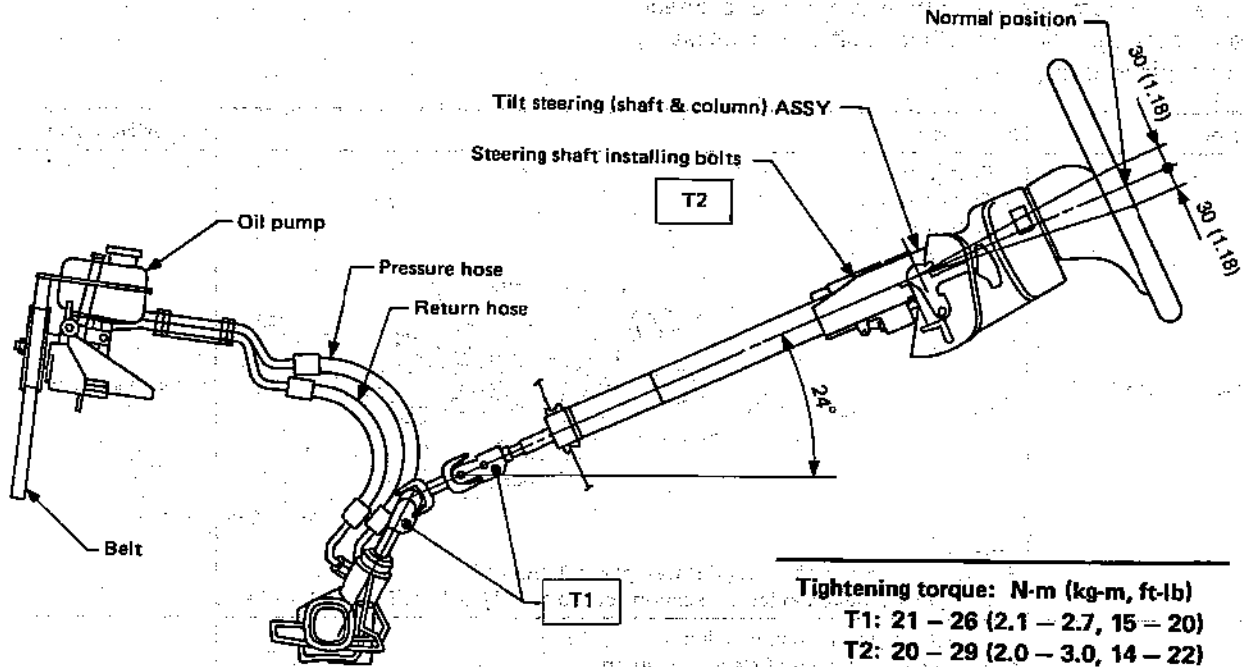


Fig. 18

B4-1550

Tilt Steering Column



Unit: mm (in)

B4-139

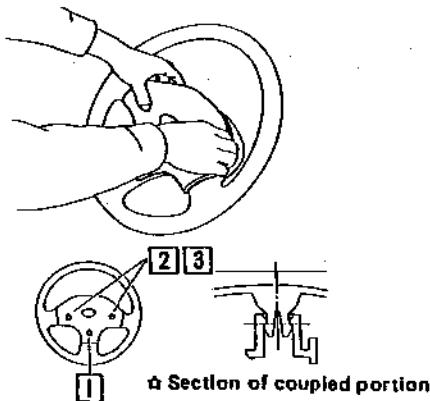
27

REMOVAL

Removal and installation of shaft ASSY and steering wheel and removal of column cover are the same as for "Steering Shaft Assembly (Rigid)".

DISASSEMBLY

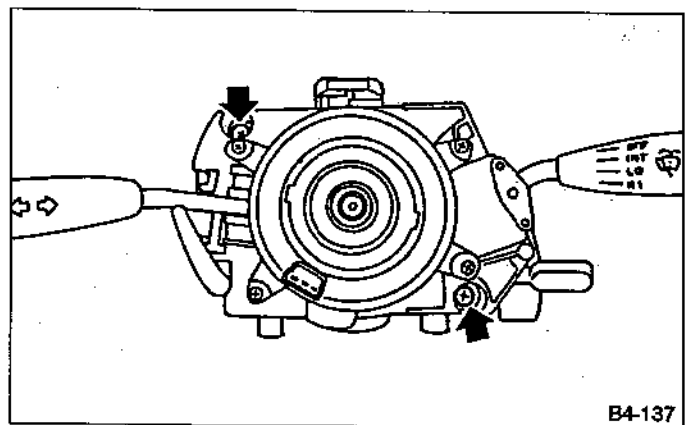
Remove lower screw and slide horn pad ASSY forward, then disconnect connector. Proceed in the numerical sequence of 1, 2 and 3.



B4-809

28

- 2) Remove steering wheel nut, then draw out wheel from shaft using steering puller.
- 3) Remove the four screws securing upper and lower steering column covers, and two screws securing combination switch, then remove related parts.

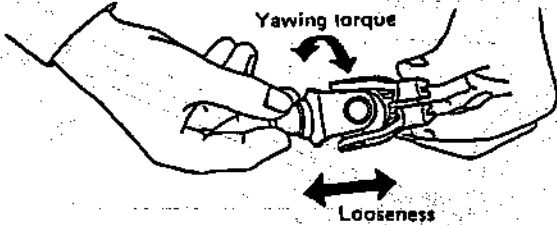
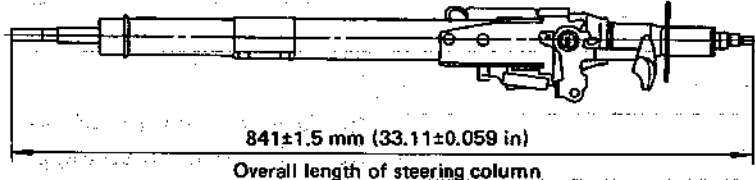


B4-137

Fig. 29

C: INSPECTION

Clean the disassembled parts with a cloth, and check for wear, damage, or any other faults. If necessary, repair or replace faulty parts.

Part name	Inspection	Corrective action
<p>Universal joint ASSY</p>	<ul style="list-style-type: none"> • Free play • Swinging torque Yawing torque Looseness  <p style="text-align: right;">B4-196A</p> <p><i>Fig. 30</i> Standard value of universal joint free play : 0 mm (0 in) Max. value of universal joint swinging torque : 0.3 N·m (0.03 kg·m, 0.2 ft·lb)</p>	<p>Replace if faulty.</p>
<p>Steering column</p>	<ul style="list-style-type: none"> • Overall length of steering column <p>Measure overall length of steering column. Standard overall length of steering column:</p>  <p style="text-align: right;">B4-1518</p> <p><i>Fig. 31</i></p>	<p>Replace steering column ASSY.</p>

D: ASSEMBLY

- 1) Insert combination switch to upper column ASSY shaft, and install lower column cover with tilt lever held in the lowered position. Then route ignition key harness and combination switch harness between column cover mounting bosses.
- 2) Fit upper column cover to lower column cover, and tighten combination switch and column cover.

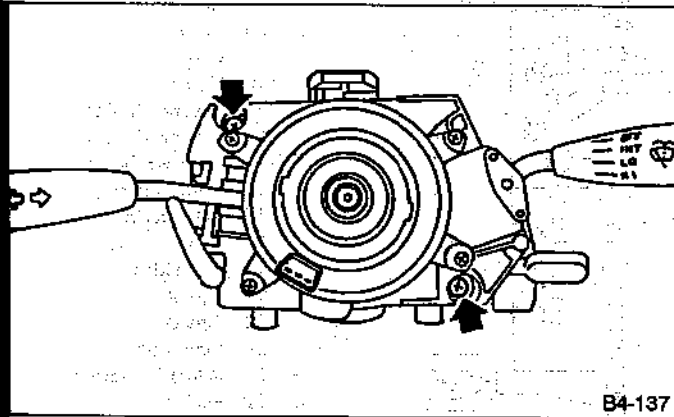


Fig. 32

Tightening torque:

1.0 — 1.4 N·m (0.10 — 0.14 kg-m, 0.7 — 1.0 ft-lb)

Don't overtorque screw.

- 3) Install coating plate to column-to-body mounting portion.

Fit coating plate securely in position by utilizing the notch provided in column.

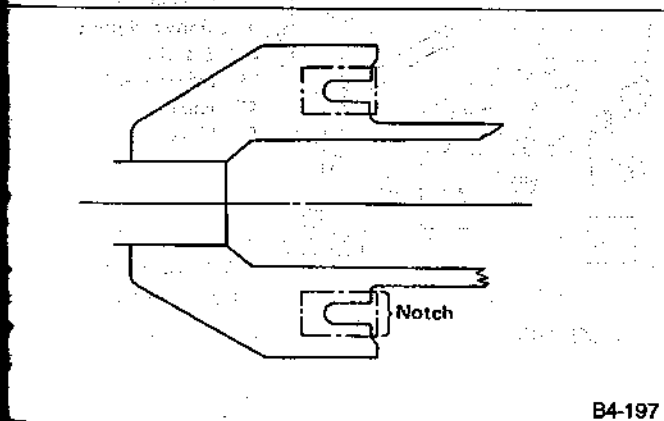


Fig. 33

- 4) Install pad ASSY to steering wheel.
 - (1) Connect harness connector of pad ASSY to connector of slip ring unit.
 - (2) Insert pad ASSY from the top and attach hooks to it.
 - (3) Secure pad ASSY to steering wheel ASSY with screws.
- 5) Install steering column ASSY on vehicle body.

Tightening torque:

20 — 29 N·m (2 — 3 kg-m, 14 — 22 ft-lb)

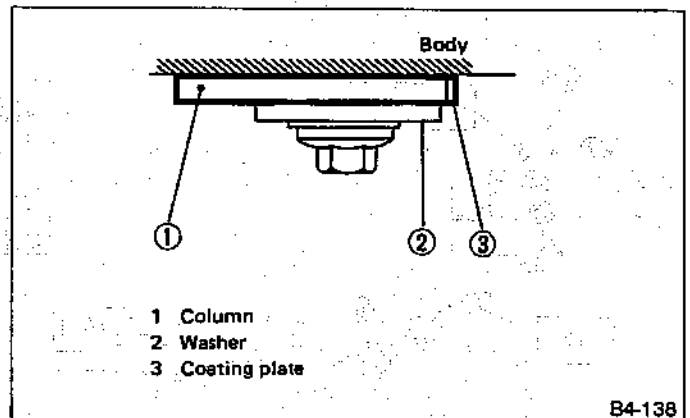
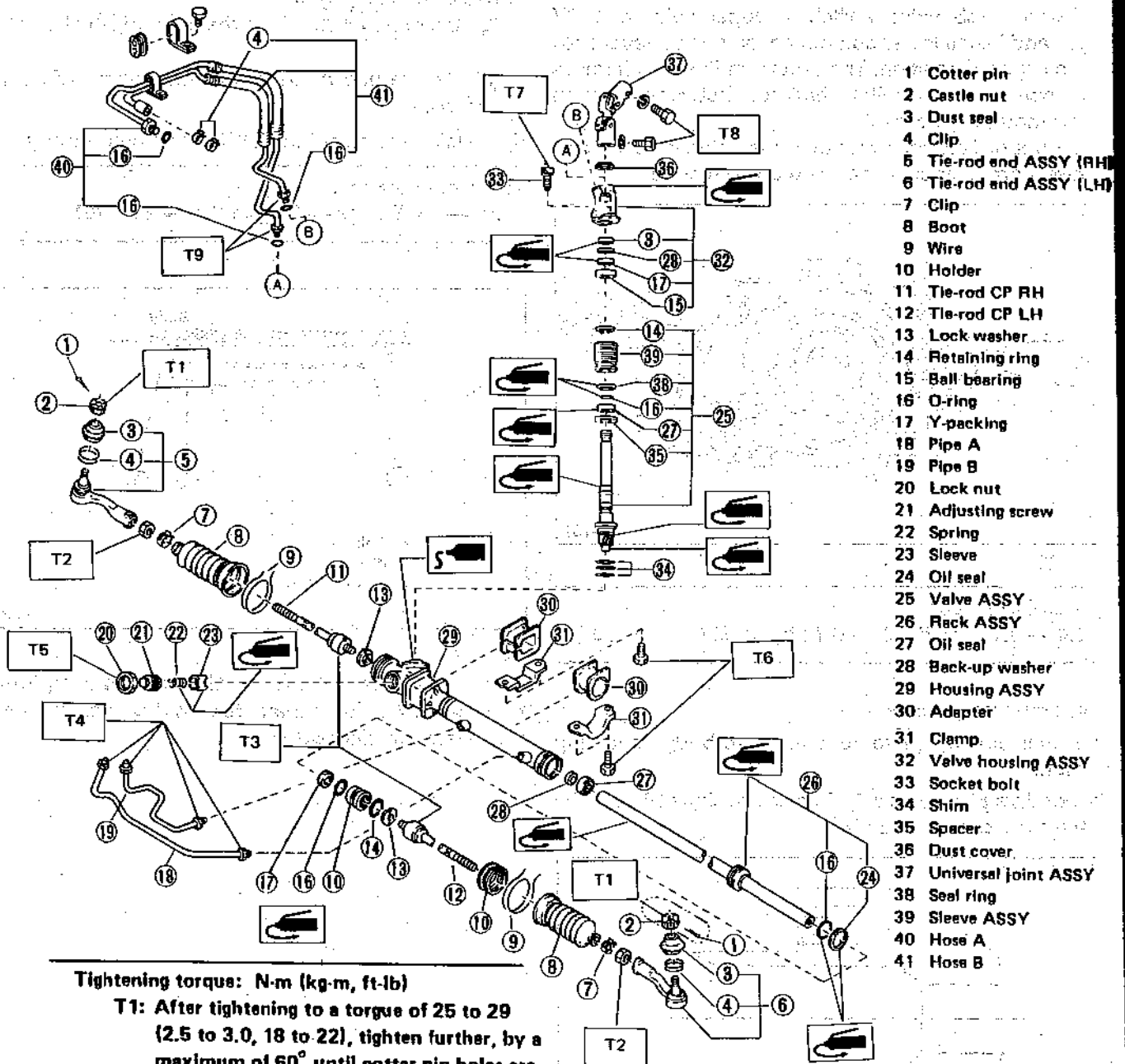


Fig. 34

Ensure that the left side of the column is tightened together with the ground terminal and that coating plates are not dislocated.

3. Steering Gearbox (Power Steering System)

For disassembly and assembly of gearbox unit, refer to section Control Valve (Power Steering Gearbox).



- 1 Cotter pin
- 2 Castle nut
- 3 Dust seal
- 4 Clip
- 5 Tie-rod end ASSY (RH)
- 6 Tie-rod end ASSY (LH)
- 7 Clip
- 8 Boot
- 9 Wire
- 10 Holder
- 11 Tie-rod CP RH
- 12 Tie-rod CP LH
- 13 Lock washer
- 14 Retaining ring
- 15 Ball bearing
- 16 O-ring
- 17 Y-packing
- 18 Pipe A
- 19 Pipe B
- 20 Lock nut
- 21 Adjusting screw
- 22 Spring
- 23 Sleeve
- 24 Oil seal
- 25 Valve ASSY
- 26 Rack ASSY
- 27 Oil seal
- 28 Back-up washer
- 29 Housing ASSY
- 30 Adapter
- 31 Clamp
- 32 Valve housing ASSY
- 33 Socket bolt
- 34 Shim
- 35 Spacer
- 36 Dust cover
- 37 Universal joint ASSY
- 38 Seal ring
- 39 Sleeve ASSY
- 40 Hose A
- 41 Hose B

Tightening torque: N-m (kg-m, ft-lb)

T1: After tightening to a torque of 25 to 29 (2.5 to 3.0, 18 to 22), tighten further, by a maximum of 60° until cotter pin holes are aligned.

T2: 78 - 88 (8.0 - 9.0, 58 - 65)

T3: 69 - 88 (7.0 - 9.0, 51 - 65)

T4: 16 - 24 (1.8 - 2.4, 12 - 17)

T5: 29 - 49 (3.0 - 5.0, 22 - 36)

T6: 47 - 71 (4.8 - 7.2, 35 - 52)

T7: 20 - 29 (2.0 - 3.0, 14 - 22)

T8: 21 - 26 (2.1 - 2.7, 15 - 20)

T9: 10 - 20 (1.0 - 2.0, 7 - 14)

Fig. 35

A: REMOVAL

- 1) Disconnect battery minus terminal.
- 2) Disconnect both O₂ sensor and exhaust gas temperature warning sensor connectors from front exhaust pipe ASSY.
- 3) Raise vehicle with a jack and remove front wheel.
- 4) Disconnect front exhaust pipe ASSY.
- 5) Remove cotter pin and castle nut. Using a puller, remove tie-rod end from knuckle arm.

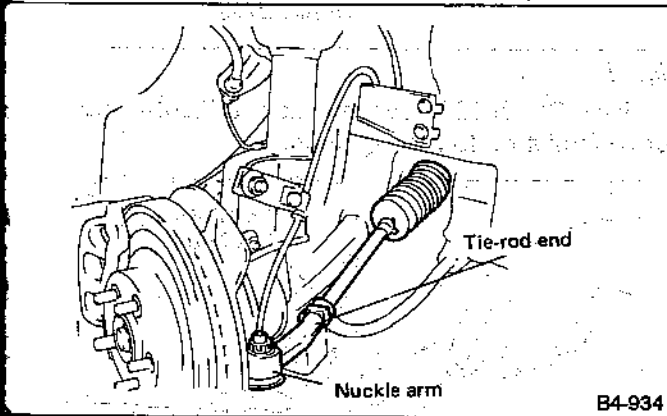


Fig. 36

- 6) Remove jack-up plate and stabilizer.

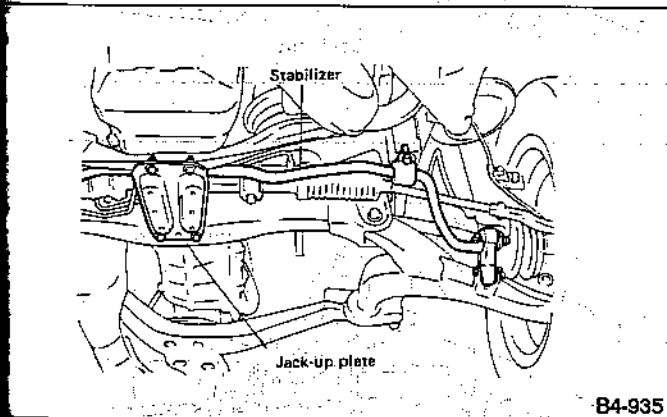


Fig. 37

- 7) Disconnect one pipe joint A from center of gearbox ASSY, and connect a vinyl hose to it. While turning steering wheel to the left and right, drain fluid through the hose. Similarly, drain fluid from the other pipe joint B.

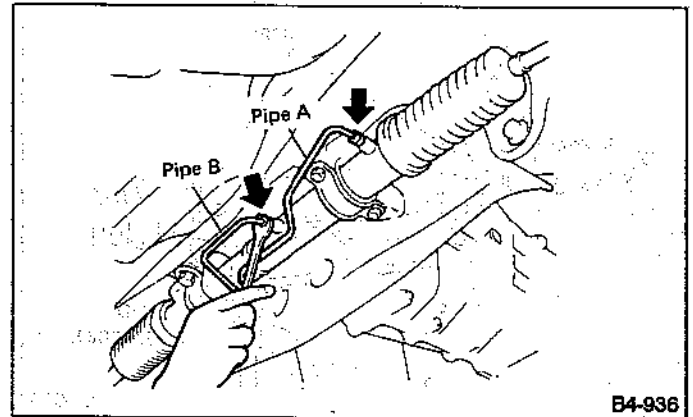


Fig. 38

- 8) Remove lower and upper bolts from universal joint ASSY, and remove universal joint in the upward direction.

Scribe alignment marks on universal joint ASSY so that it can be reassembled at the original serration.

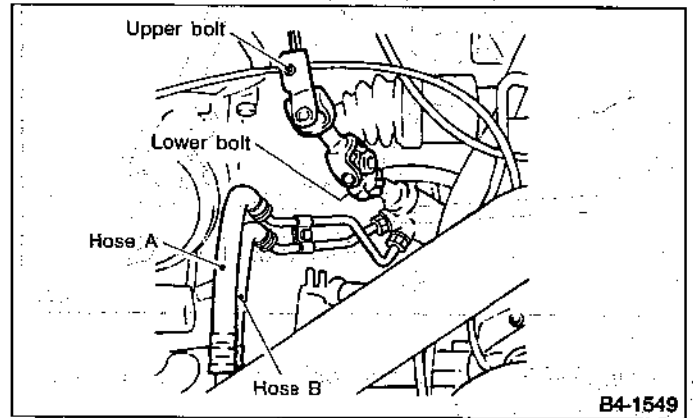


Fig. 39

- 9) Remove flare nuts from control valve of gearbox ASSY, and disconnect upper and lower hoses B and A.

- Always disconnect hoses B and A in that order.
- Be careful not to damage the hoses during removal.

- 10) Remove bolts securing gearbox to crossmember, and detach gearbox.

Tightening torque:

47 — 71 N·m (4.8 — 7.2 kg-m, 35 — 52 ft-lb)

B: DISASSEMBLY

- 1) Disconnect four pipes from gearbox.
- 2) Secure gearbox removed from vehicle in vice using STAND (926200000).

Secure the gearbox ASSY in a vice using the special tool as shown. Do not attempt to secure it without this special tool.

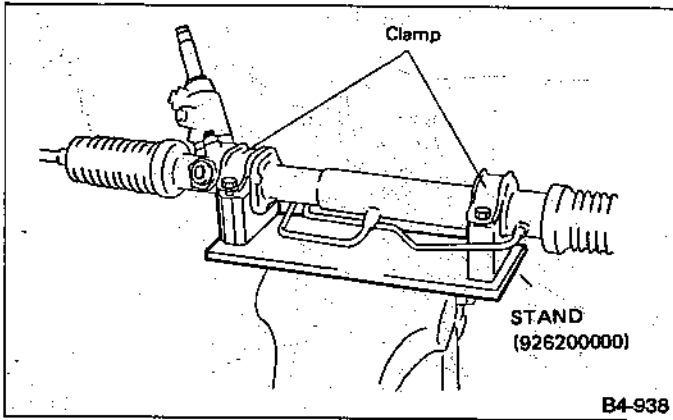


Fig. 40
3) Pry off clip from outer end of boot, and slide boot toward tie-rod end.

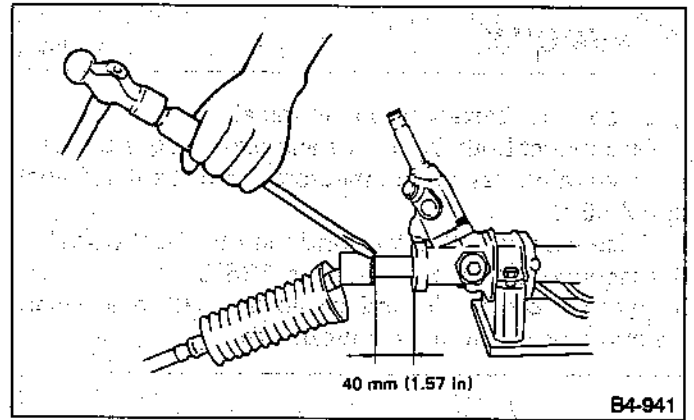


Fig. 43
6) Using SPANNER, loosen lock nut. Tighten adjusting screw until it no longer tightens.

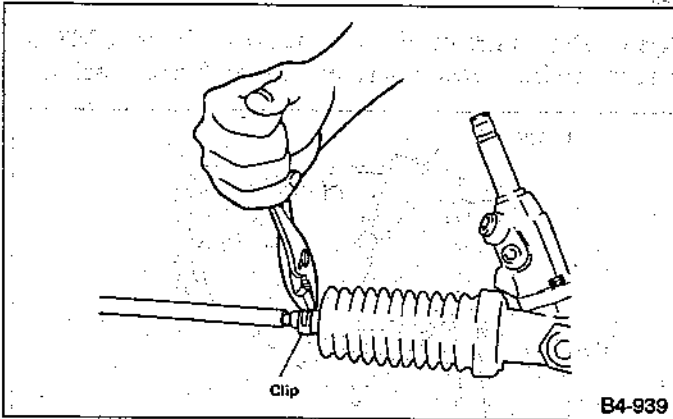


Fig. 41
4) Using WRENCH, remove lock wire from inner end of boot, and remove boot.

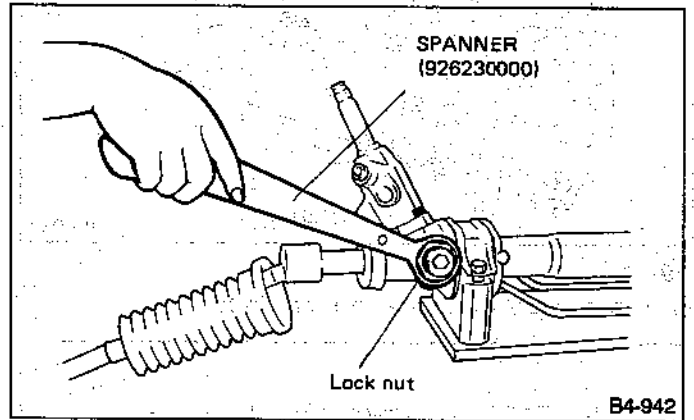


Fig. 44

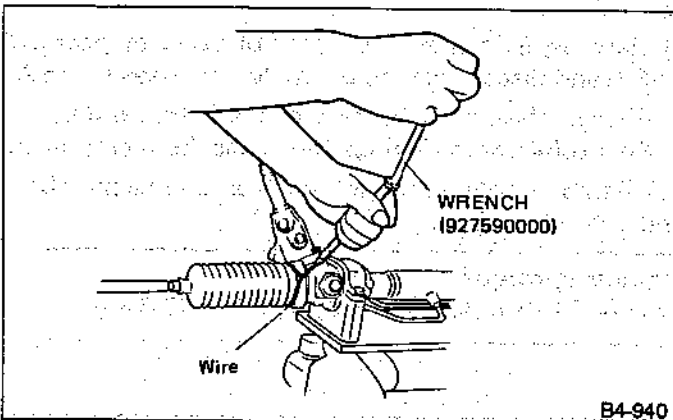


Fig. 42
5) Extend rack approximately 40 mm (1.57 in) out. Unlock lock wire at lock washer on each side of tie-rod end using a standard screwdriver. Be careful not to scratch rack surface as oil leaks may result.

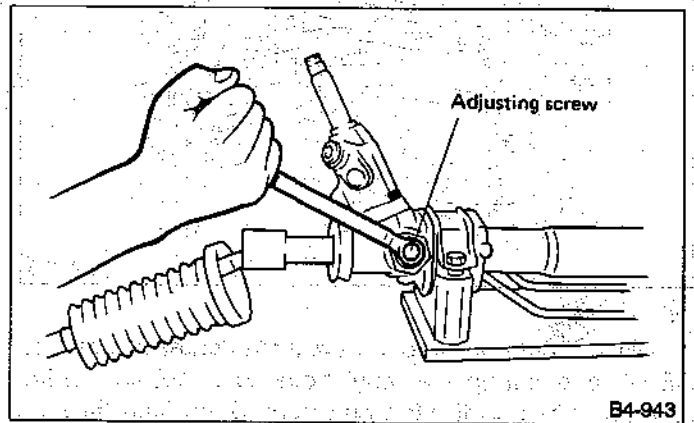


Fig. 45
7) Using a wrench (32 mm width across flats) or adjustable wrench, remove tie-rod CP.

- Check ball joint for free play, and tie-rod for bends; replace if necessary.
- Check dust seals used with tie-rod end ball joint for damage or deterioration. Replace if necessary.

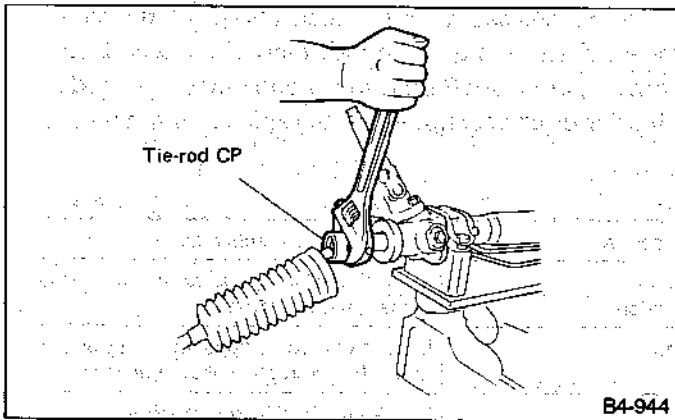


Fig. 46

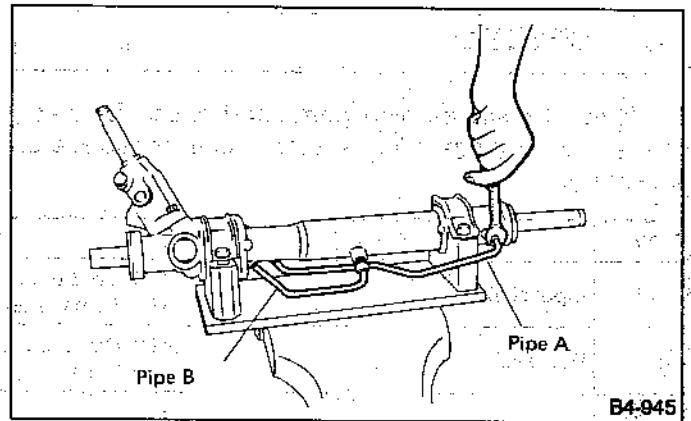


Fig. 47

8) Loosen adjusting screw and remove spring and sleeve.

Replace spring and/or sleeve if damaged.

9) Disconnect pipes A and B from steering body and control valve housing.

Replace pipes and/or flare nuts if damaged.

C: INSPECTION

1) Clean all disassembled parts, and check for wear, damage, or any other faults, then repair or replace as necessary.

2) When disassembling, check inside of gearbox for water. If any water is found, carefully check boot for damage, input shaft dust seal, adjusting screw and boot clips for poor sealing. If faulty, replace with new parts.

No.	Parts	Inspection	Corrective action
1	Input shaft	(1) Bend of input shaft (2) Damage on serration	If bend or damage is excessive, replace entire gearbox ASSY.
2	Dust seal	(1) Crack or damage (2) Wear	If outer wall slips, lip is worn out or damage is found, replace it with new one.
3	Rack and pinion	Poor mating of rack with pinion	(1) Adjust backlash properly. By measuring turning torque of gearbox and sliding resistance of rack, check if rack and pinion engage uniformly and smoothly with each other. (Refer to "Service limit".) (2) Keeping rack pulled out all the way so that all teeth emerge, check teeth for damage. Even if abnormality is found in either (1) or (2), replace entire gearbox ASSY.
4	Gearbox unit	(1) Bend of rack shaft (2) Bend of cylinder portion (3) Crack or damage on cast iron portion	Replace gearbox ASSY with new one.
		(4) Wear or damage on rack bush	If free play of rack shaft in radial direction is out of the specified range, replace gearbox ASSY with new one. (Refer to "Service limit".)
		(5) Wear on input shaft bearing	If free plays of input shaft in radial and axial directions are out of the specified ranges, replace gearbox ASSY with new one. (Refer to "Service limit".)
5	Boot	Crack, damage or deterioration	Replace.
6	Tie-rod CP	(1) Looseness of ball joint (2) Bend of tie-rod	Replace.
7	Tie-rod end	Damage or deterioration on dust seal	Replace.
8	Adjusting screw spring	Deterioration	Replace.
9	Boot clip	Deterioration	Replace.
10	Sleeve	Damage	Replace.
11	Pipes	(1) Damage to flared surface (2) Damage to flare nut (3) Damage to pipe	Replace.

1. SERVICE LIMIT

Make a measurement as follows. If it exceeds the specified service limit, adjust or replace.

When making a measurement, vise gearbox by using special tool (STAND: 926200000). Never vise gearbox by inserting aluminum plates, etc. between vise and gearbox.

Sliding resistance of rack shaft

Service limit:

304 N (31 kg, 68 lb) or less

Difference between left and right sliding resistance:

Less than 20%

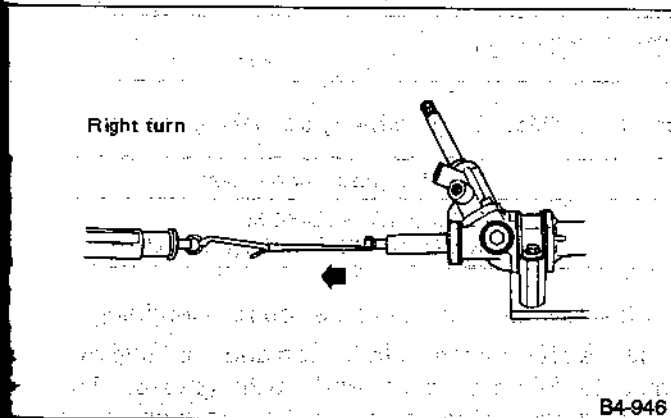


Fig. 48 Right-turn steering

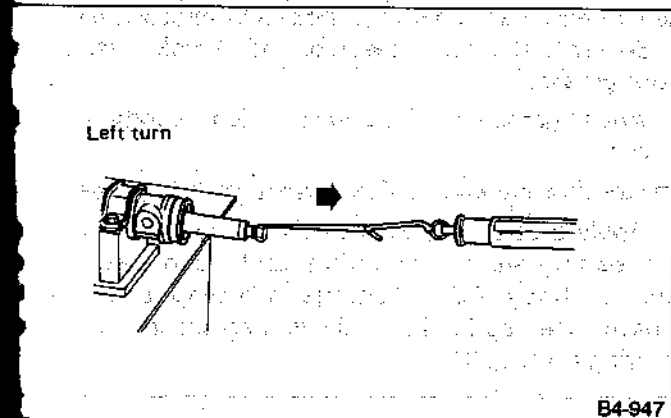


Fig. 49 Left-turn steering

RACK SHAFT PLAY IN RADIAL DIRECTION

Right-turn steering

Service limit:

Less than 0.4 mm (0.016 in) (direction ← →)

Less than 0.6 mm (0.024 in) (direction ↔)

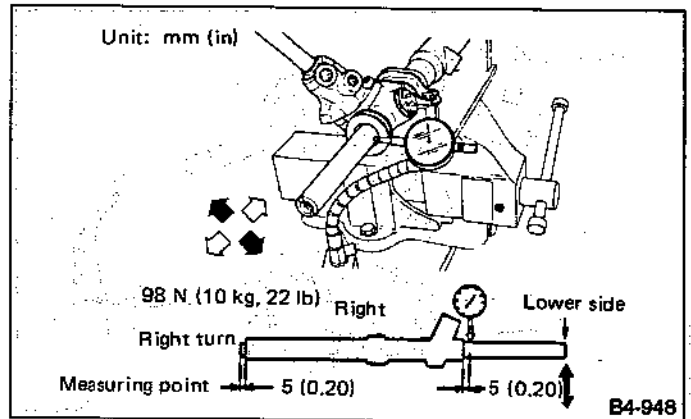


Fig. 50

• Left-turn steering

Service limit:

Less than 0.4 mm (0.016 in) (direction ← → and ↔)

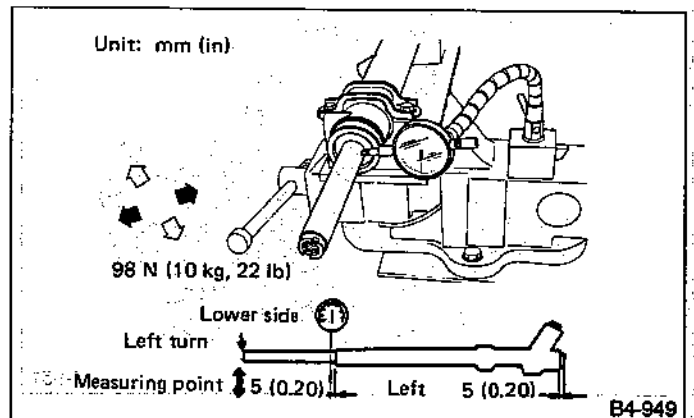


Fig. 51

3. INPUT SHAFT PLAY

• In radial direction

Service limit:

0.18 mm (0.0071 in) or less

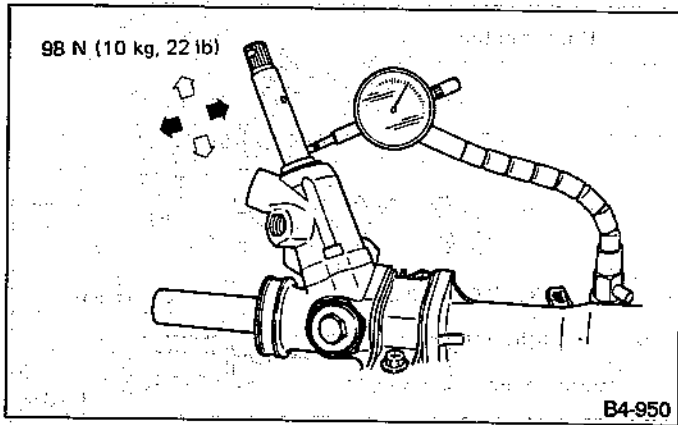


Fig. 52

- In axial direction

Service limit:

0.27 mm (0.0106 in) or less

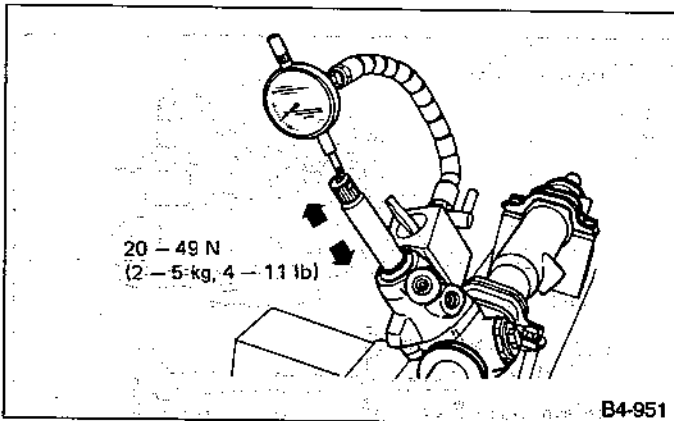


Fig. 53

4. TURNING RESISTANCE OF GEARBOX

Service limit:

Straight-ahead position within 30 mm (1.18 in) from rack center

Less than 11.18 N (1.14 kg, 2.51 lb)

Maximum allowable resistance

15.79 N (1.61 kg, 3.55 lb) or less

Difference between left and right sliding resistance:

Less than 20%

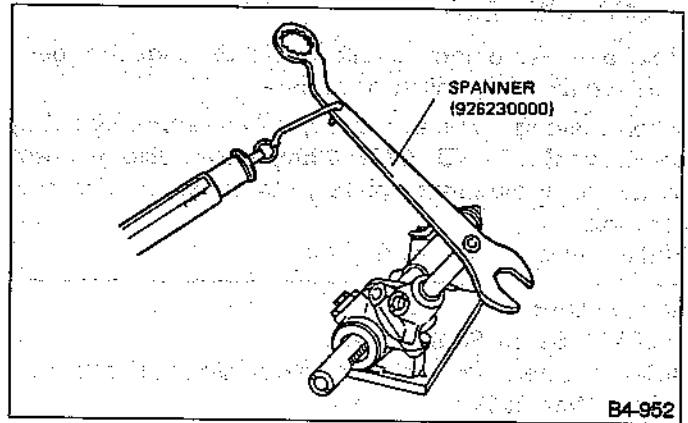


Fig. 54

D: ASSEMBLY

Use only SUBARU genuine grease for gearbox.

Specified grease for gearbox
VALIANT GREASE M2 [Parts No. 003608001, net 0.5 kg (1.1 lb)]

- Clean all parts and tools before reassembling.
- 1) Move rack shaft fully to the left and right two or three times to lubricate shaft ends with grease. Remove excess grease, being careful not to block air vent hole.
- When rack is fully moved to its stroke ends with tie-rod removed, be careful not to bump rack ends.
- Ensure that screw located at end of rack shaft is free from grease.
- 2) Apply grease to bore wall which accommodates sleeve.

Ensure that hands are clean when applying grease.

- 3) Apply a coat of grease to sliding surface of sleeve and seating surface of spring, and insert sleeve into steering body ASSY. Charge adjusting screw with grease, insert spring into adjusting screw and install on steering body ASSY.

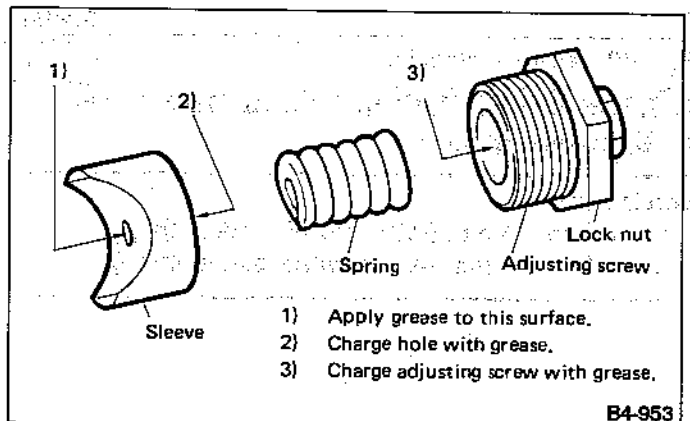


Fig. 55

- 4) Installation of tie-rod CP

- (1) Rotate input shaft until rack extends approximately 40 mm (1.57 in).
- (2) Tighten adjusting screw until it will no longer tighten.
- (3) Install lock washers and tighten left and right tie-rod CPs into rack ends.

Tightening torque:

69 — 88 N·m (7.0 — 9.0 kg-m, 51 — 65 ft-lb)

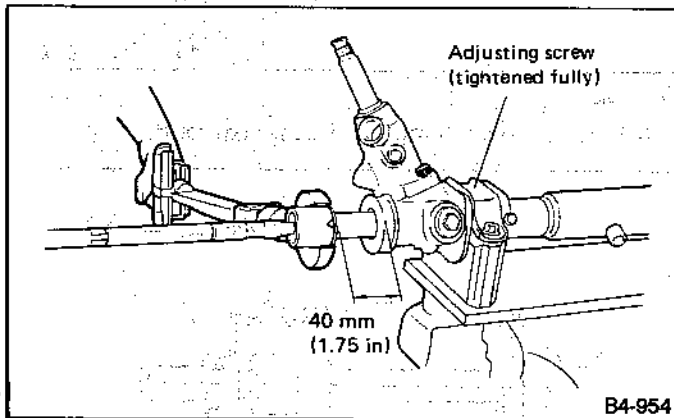


Fig. 56

The left and right tie-rod CP differ as indicated in the table below.

Right tie-rod (pinion side)	No air vent hole provided	Grooved (for identification)
Left tie-rod (cylinder side)	Air vent hole provided	Not grooved (for identification)

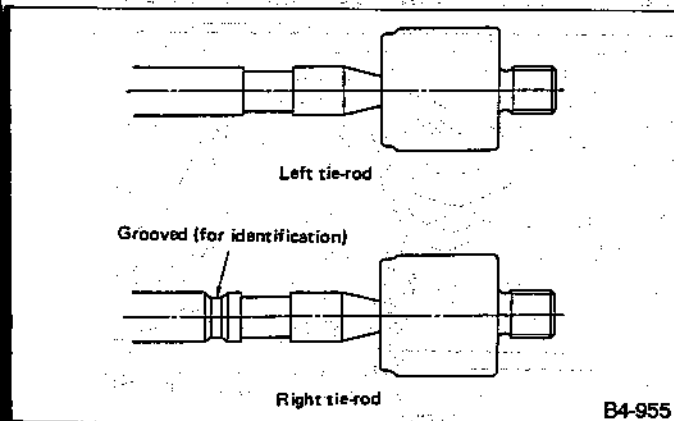


Fig. 57

- (4) Using a chisel and hammer, bend lock washers (at two places).

Be careful not to scratch rack.

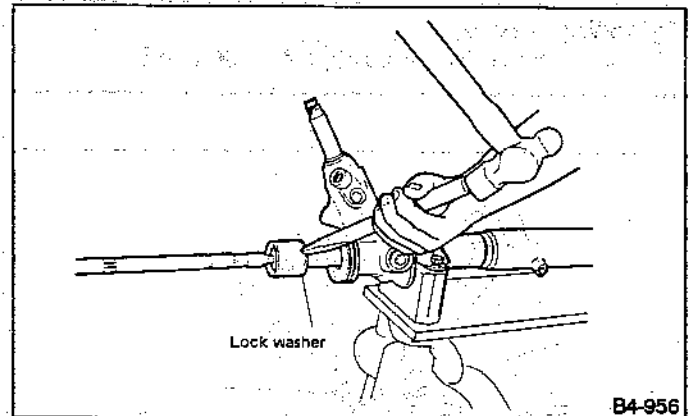


Fig. 58

5) Rack & pinion backlash adjustment

- (1) Loosen adjusting plug.
- (2) Rotate input shaft so that rack is in the straight ahead direction. [Ensure that distance between rack end and stopper is 72.4 mm (2.850 in).]
- (3) Tighten adjusting plug by two threads.

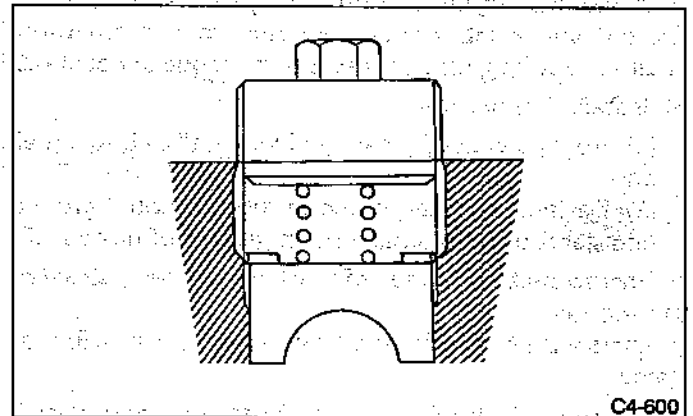


Fig. 59

- (4) Turn adjusting screw so that the entire thread area is coated with liquid packing.
 - a. Apply liquid packing of approximately 1.5 grams (0.053 oz) to adjusting screw thread area.
 - b. Also turn plug to ensure that its entire contact area is coated with liquid packing.

Liquid packing:

Three-bond 1102 or equivalent

- (5) Tighten adjusting plug to 20 N·m (2.0 kg-m, 14 ft-lb) and loosen, then tighten to 5 N·m (0.5 kg-m, 3.6 ft-lb) and loosen, and finally tighten to 5 N·m (0.5 kg-m, 3.6 ft-lb) and loosen 25°.
- (6) While holding adjusting plug using a closed wrench, tighten lock nut using LOCK NUT WRENCH.

Tightening torque:

29 — 49 N•m (3 — 5 kg-m, 22 — 36 ft-lb)

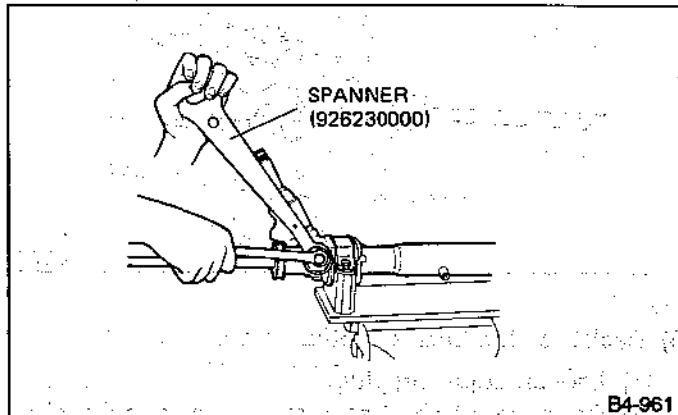


Fig. 60

- Do not allow liquid packing to come in contact with sleeve.
- While rotating input shaft to fully move rack shaft to the left and right, ensure that rack moves smoothly without binding, and that rotating torque is constant.

6) Installation of boot

(1) Apply a coat of grease to inner wall of boot small end.

(2) Position boot large end in rubber mount groove and gearbox, and small end in groove of tie-rod CP.

- Ensure that both ends of boot are properly situated in grooves.
- Ensure that boot is free from abnormal swelling or dents.

(3) Attach lock wire to boot large end, and twist it while pulling it upward (with a force of approximately 29 — 49 N (3 — 5 kg, 7 — 11 lb)). Then bend wire end along boot as shown.

Ensure that lock wire is not loose.

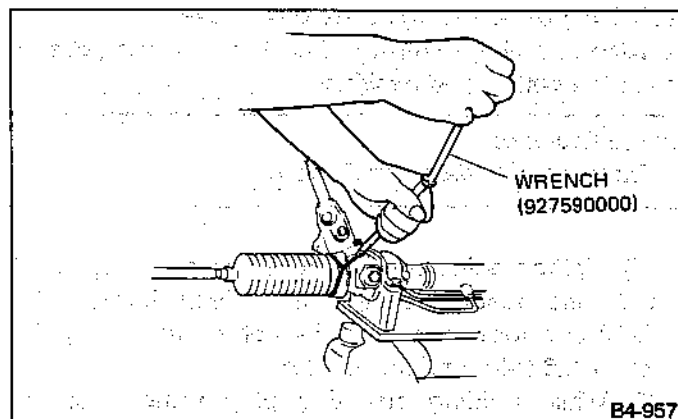


Fig. 61

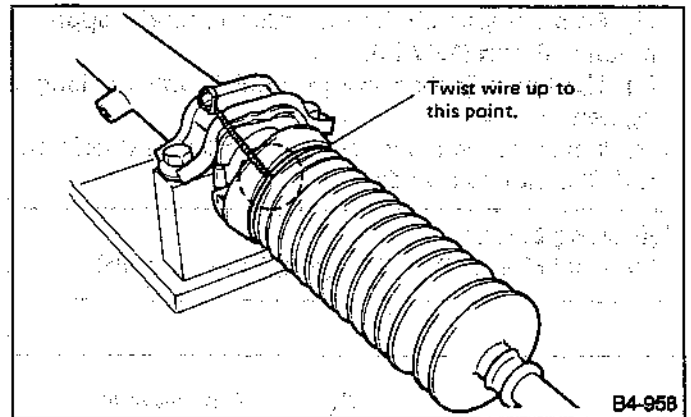


Fig. 62

(4) Bend down flange of boot large end.

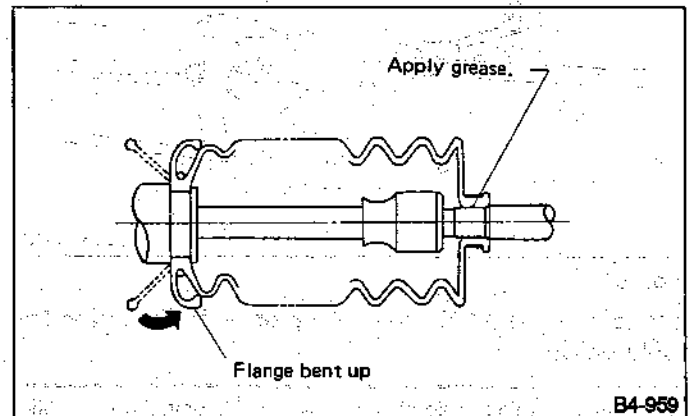


Fig. 63

(5) Install clip using pliers.

After installing clip, ensure that boot's small end is properly positioned in groove on tie-rod CP.

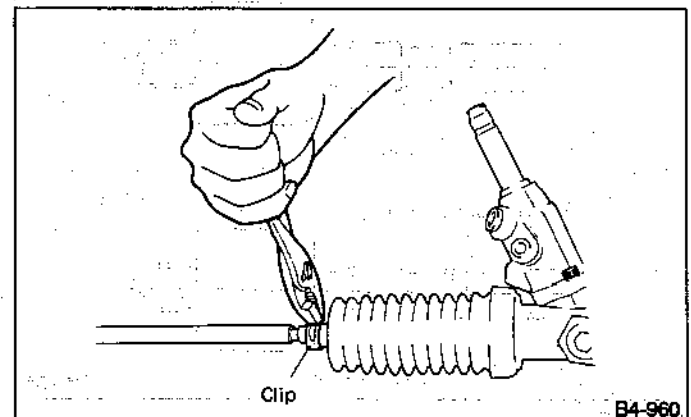


Fig. 64

7) Install pipe ASSYs A and B.

Tightening torque:

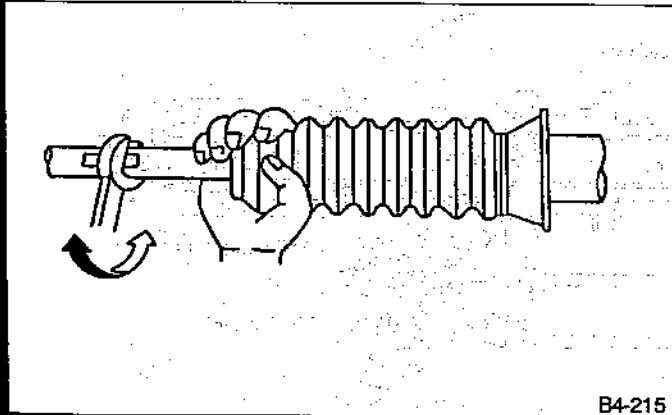
16 — 24 N•m (1.6 — 2.4 kg-m, 12 — 17 ft-lb)

E: INSTALLATION

Installation is in the reverse order of removal.

Observe the following:

When adjusting toe-in, hold boot as shown to prevent it from being rotated or twisted. If twisted, straighten it.



B4-215

Fig. 65

F: ADJUSTMENT

Adjust front toe.

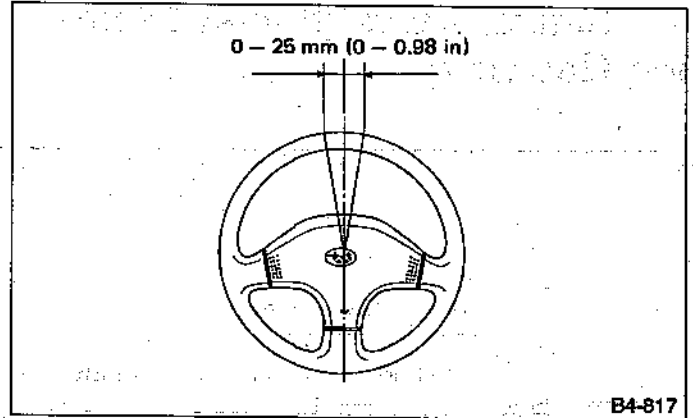
Standard of front toe:

IN 3 — OUT 3 mm (IN 0.12 — OUT 0.12 in)

Adjust steering angle of wheels.

Model	Inner wheel	Outer wheel
ion TURBO	39° ±1.5°	33.5° ±1.5°
TURBO	36.5° ±1.5°	32.0° ±1.5°

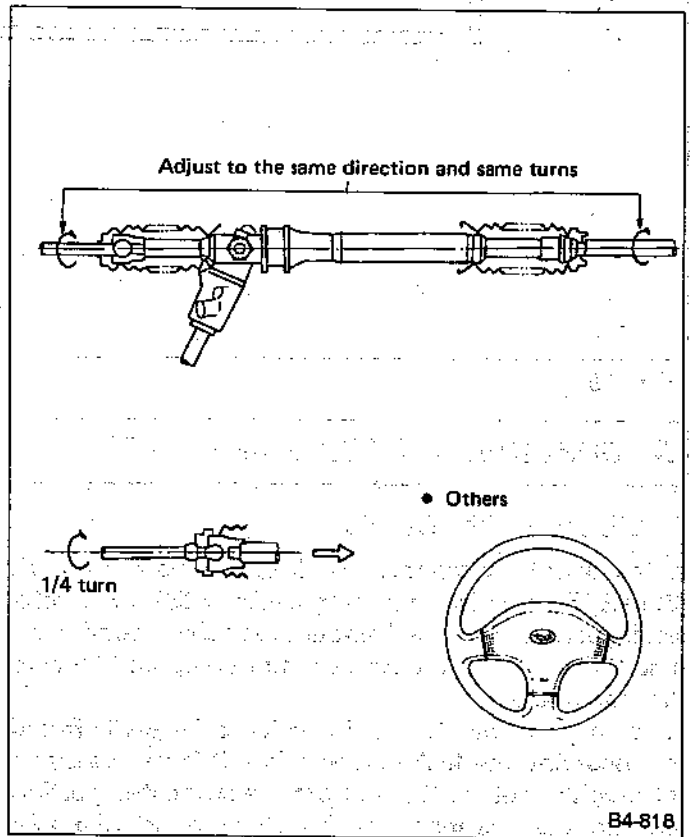
If steering wheel spokes are not horizontal when wheels are set in the straight ahead position, and error more than 5° on the periphery of steering wheel, correctly re-install the steering wheel.



B4-817

Fig. 66

If steering wheel spokes are not horizontal with vehicle set in the straight ahead position after this adjustment, correct it by turning the right and left tie-rods in the same direction by the same amount.



B4-818

Fig. 67

4. Control Valve (Power Steering Gearbox)

This section focuses on the disassembly and reassembly of control valve. For the inspection and adjustment and the service procedures for associated parts, refer to "Steering Gearbox (Power Steering System)".

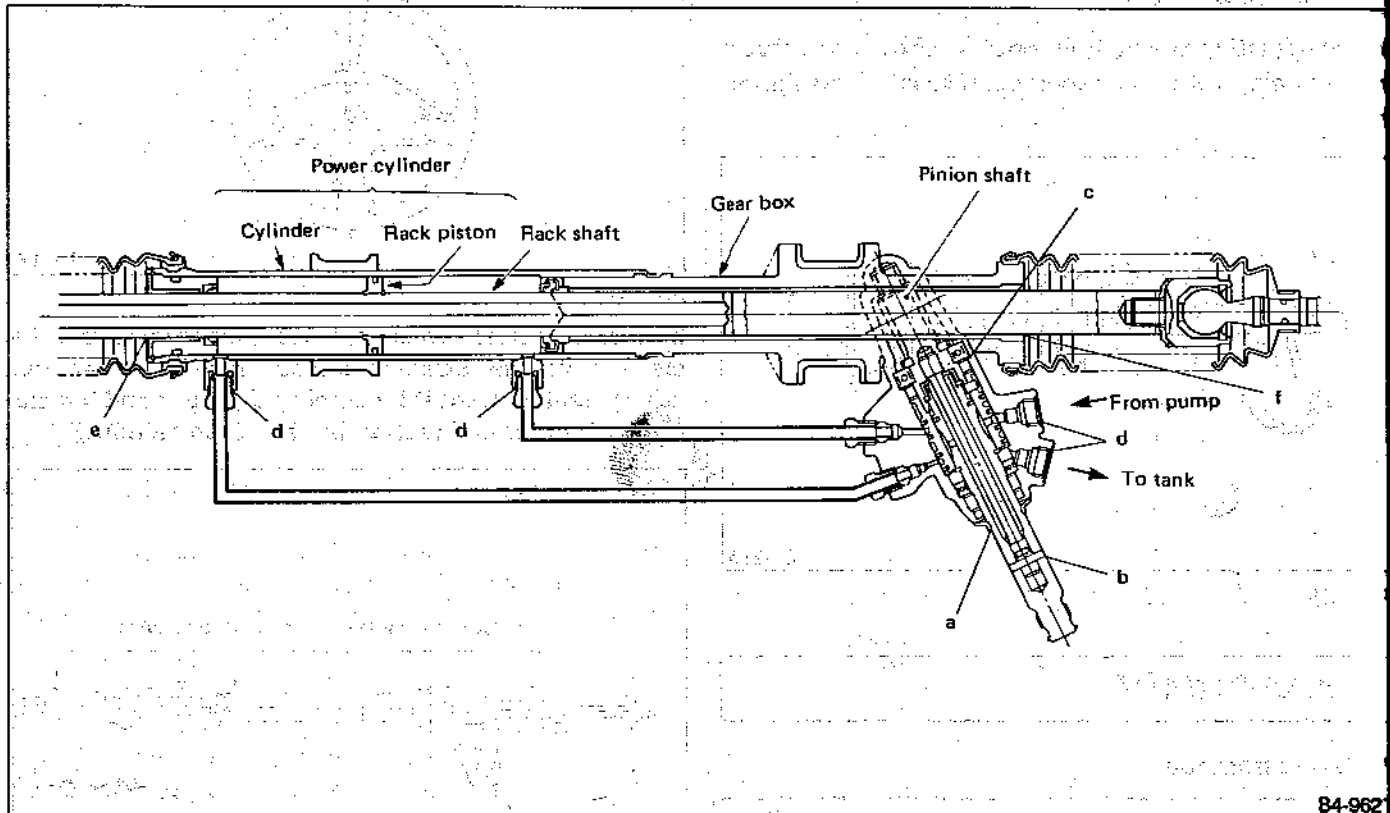


Fig. 68

A: CHECKING OIL LEAKING POINTS

1. OIL LEAKING POINTS

a. If leak point is other than a, b, c, or d, perform check (5) in 2) before dismounting gearbox ASSY from vehicle. If gearbox ASSY is dismounted without confirming where the leak is, it must be mounted again to locate the leak point.

b. Even if the location of the leak can be easily found by observing the leaking condition, it is necessary to thoroughly remove the oil from the suspected portion and turn the steering wheel from lock to lock about 30 to 40 times with engine running, then make comparison of the suspected portion between immediately after and several hours after this operation.

c. Before starting oil leak repair work, be sure to clean the gearbox ASSY, hoses, pipes, and surrounding parts. After completing repair work, clean these areas again.

2. OIL LEAK CHECK PROCEDURE AND REPLACEMENT PARTS

Parts requiring replacement are described in the smallest unit of spare parts including damaged parts and spare parts damaged. In actual disassembly work accidental damage as well as inevitable damage to some related parts must be taken into account, and spare parts for them must also be prepared. However, it is essential to pinpoint the cause of trouble, and limit the number of replacement parts as much as possible.

- 1) Leakage from "a"
The oil seal is damaged. Replace valve ASSY with a new one.
- 2) Leakage from "b"
The torsion bar O-ring is damaged. Replace valve ASSY with a new one.
- 3) Leakage from "c"
The oil seal is damaged. Replace valve ASSY with a new one.
- 4) Leakage from "d"
The pipe ASSY is damaged. Replace the faulty pipe ASSY or O-ring.
- 5) If leak is other than a, b, c, or d, and if oil is leaking from the gearbox ASSY, move the right and left boots

toward tie-rod end side, respectively, with the gearbox ASSY mounted to the vehicle, and remove oil from the surrounding portions. Then, turn the steering wheel from lock to lock 30 to 40 times with the engine running, then make comparison of the leaked portion immediately after and several hours after this operation.

(1) Leakage from "e"

The cylinder seal is damaged. Replace rack bush ASSY with a new one.

(2) Leakage from "f"

There are two possible causes. Take following step first. Remove the pipe ASSY B from the valve housing, and close the circuit with PLUG (926420000). Turn the steering wheel from lock to lock 30 to 40 times with the engine running, then make comparison of the leaked portion between immediately after and several hours after this operation.

a. If leakage from "f" is noted again:

The oil seal of pinion & valve ASSY is damaged. Replace pinion & valve ASSY with a new one. Or replace the oil seal and the parts that are damaged during disassembly with new ones.

b. If oil stops leaking from "f":

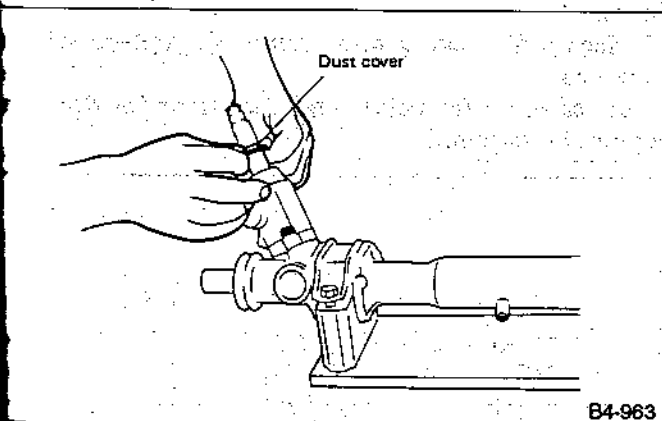
The oil seal of rack housing is damaged. Replace the oil seal and the parts that are damaged during disassembly with new ones.

B: DISASSEMBLY

1) Slide dust cover out.

Be careful not to scratch housing or input shaft during dust cover removal. Also do not allow foreign matter to enter housing interior.

Replace dust cover with a new one if its inside bore or lips are worn or damaged.

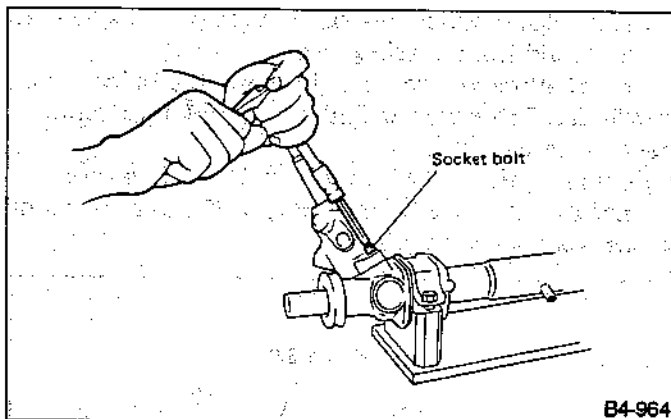


B4-963

Fig. 69

2) Removal of valve ASSY

(1) Remove the two bolts securing valve housing ASSY.

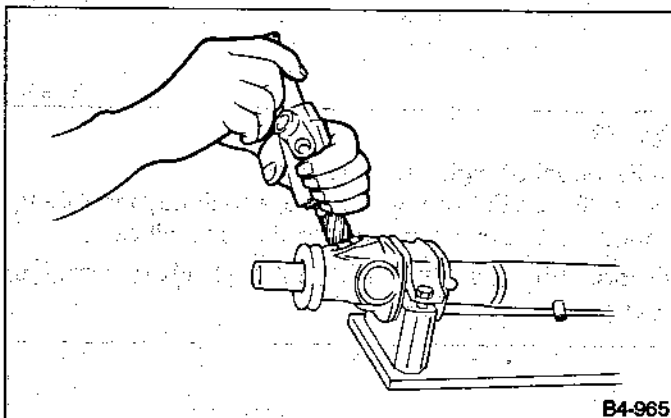


B4-964

Fig. 70

(2) Remove valve housing ASSY, pinion and valve ASSY as a unit.

Extract input shaft when removing valve ASSY.

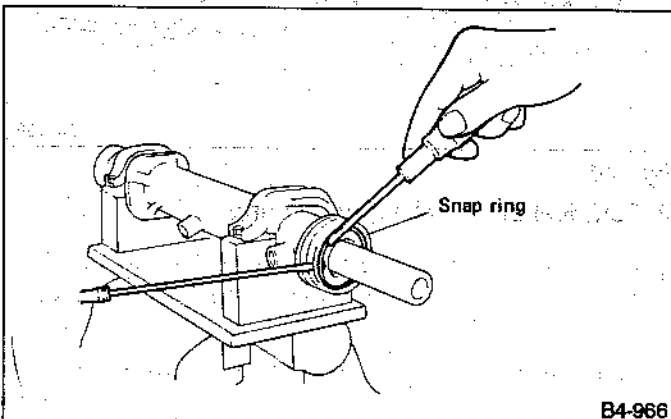


B4-965

Fig. 71

3) Removal of snap ring from seal holder ASSY

While attaching small screwdriver blade to snap ring via groove on boot (on cylinder side of steering body ASSY), push the snap ring using another screwdriver.



B4-966

Fig. 72

4) Removal of rack ASSY

Push rack out of steering body ASSY while pushing it on valve side.

- Block pipe connection of steering body ASSY to prevent fluid from flowing out.
- Do not allow rack to come in contact with inner wall of cylinder. Otherwise, cylinder wall may be scratched, resulting in oil leaks.
- Remove holder ASSY and rack ASSY as a unit.
- Check rack and steering body ASSY for bends or cracks; replace as required.

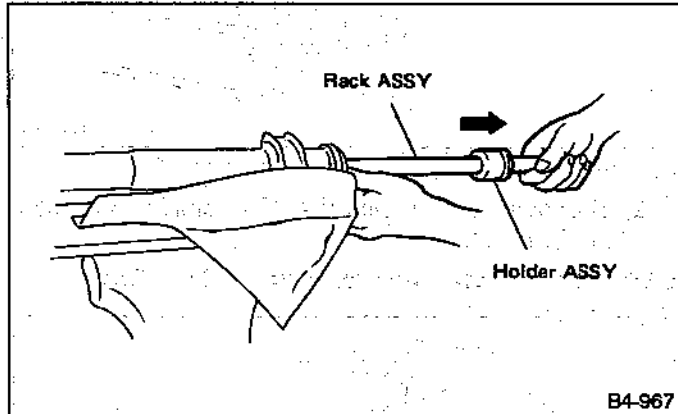


Fig. 73

- 5) Removal of high-pressure seal
Insert REMOVER from valve side, and lightly tap it using a hammer to drive out back-up ring and oil seal. Discard back-up ring and oil seal after removal; replace with new ones.

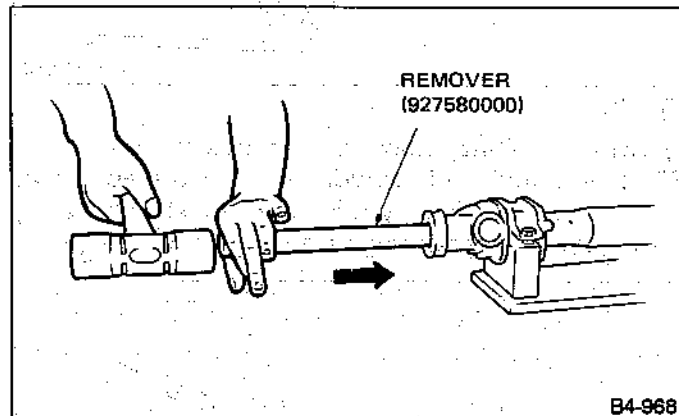


Fig. 74

- 6) Removal of Y-packing and O-ring

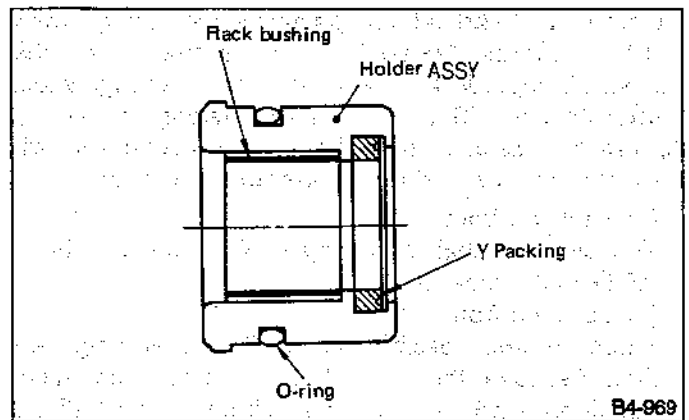


Fig. 75

- (1) Using a small rod, pry out Y-packing.
 - Be careful not to scratch Y-packing groove on holder ASSY. A scratch may cause oil leaks.
 - Be careful not to scratch mating surfaces of holder ASSY and rack. A scratch may cause oil leaks.
 - Check rack bushing for wear or damage; replace as required.
 - Discard Y-packing and O-ring after removal; replace with new ones.
- (2) Remove O-ring.
- (3) Apply a coat of grease to Y-packing groove in holder ASSY.
- (4) Install a new Y-packing and O-ring.

C: REPLACEMENT OF SEAL AND PACKING

- 1) Disassembly and reassembly of valve ASSY
 - (1) After removing dust cover, extract pinion & valve ASSY from valve housing.
 - If pinion & valve ASSY is difficult to remove, use a press.
 - Discard Y-packing after removal; replace with a new one.
 - Check rotor for bends and serrations for damage; replace as required.

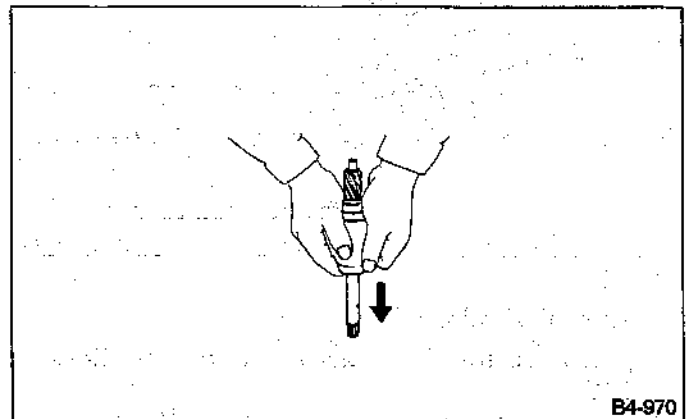


Fig. 76

(2) Using REMOVER and press, remove dust seal, back-up washer, Y-packing and ball bearing from valve housing.

- Use the "A" end of remover.
- Do not apply a force to end surface of valve housing.
- Do not reuse Y-packing after removal.

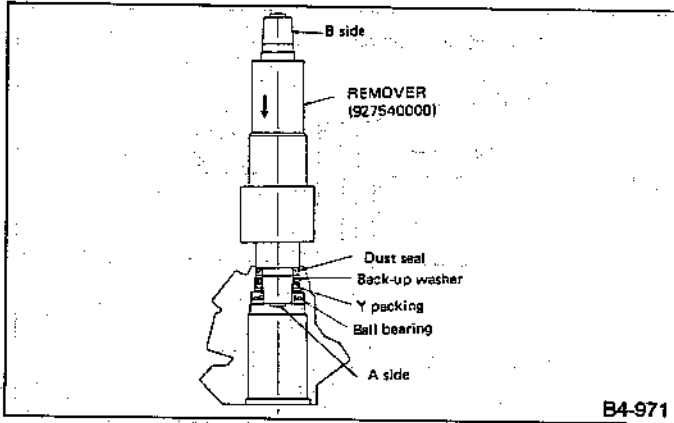


Fig. 77

(3) Remove snap ring securing valve sleeve to pinion & valve ASSY, and remove valve sleeve.

Be careful not to scratch pinion & valve ASSY when removing snap ring.

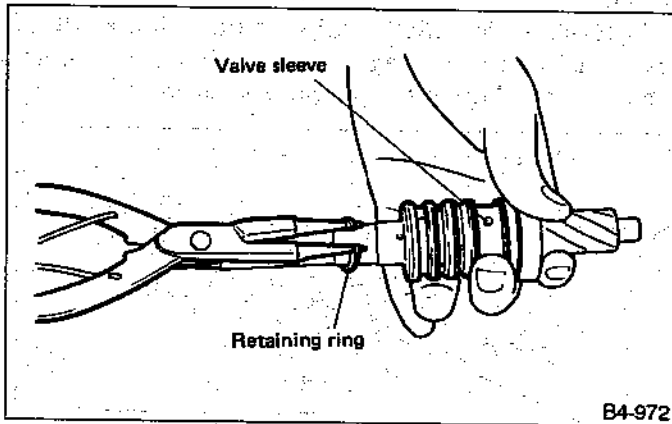


Fig. 78

(4) Remove oil seal and spacer.

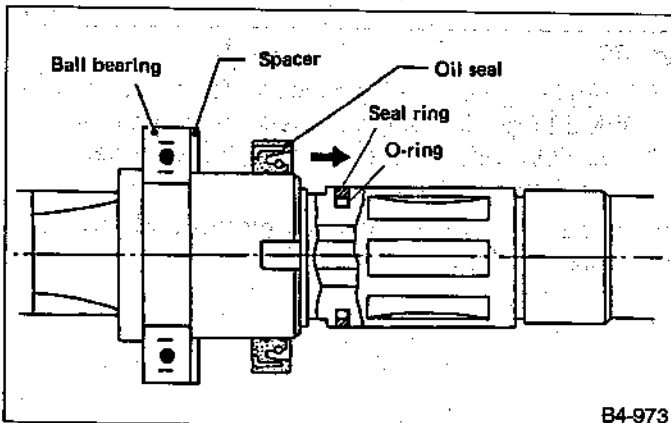


Fig. 79

(5) Using a long rod, remove seal ring and O-ring from pinion ASSY.

Be careful not to scratch outer surface and seal ring groove of input shaft. If scratched, sealing effect will be lost, resulting in a malfunctioning valve.

(6) Wash and clean pinion & valve ASSY and valve housing.

(7) Attach COVER (926270000) to pinion ASSY, and apply grease to outer perimeter of the cover and mating surface of oil seal.

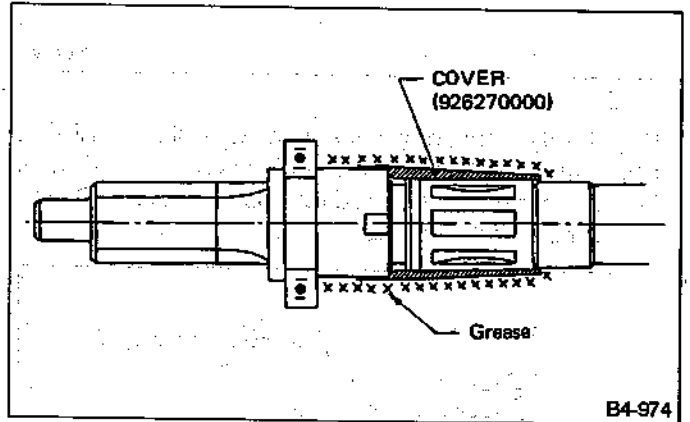


Fig. 80

(8) Apply a coat of grease to spacer and sealing lips of oil seal, and install spacer and oil seal.

- Face chamfered side of spacer toward oil seal.
- Face oil seal in correct direction.

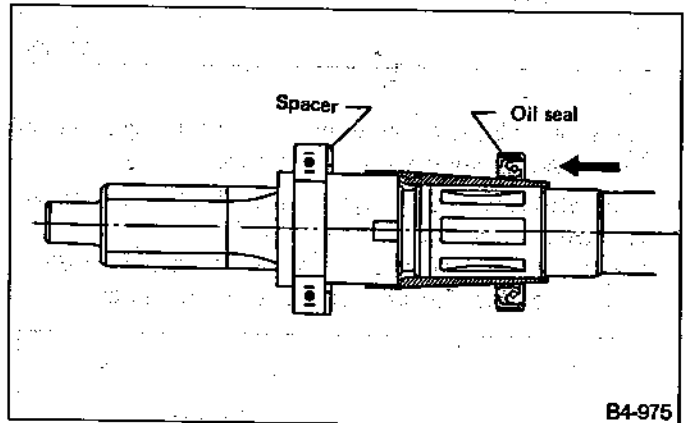


Fig. 81

(9) Install COVER to input shaft, and apply a coat of grease to the cover surface. Install O-ring and seal ring.

Do not expand O-ring and seal ring more than necessary.

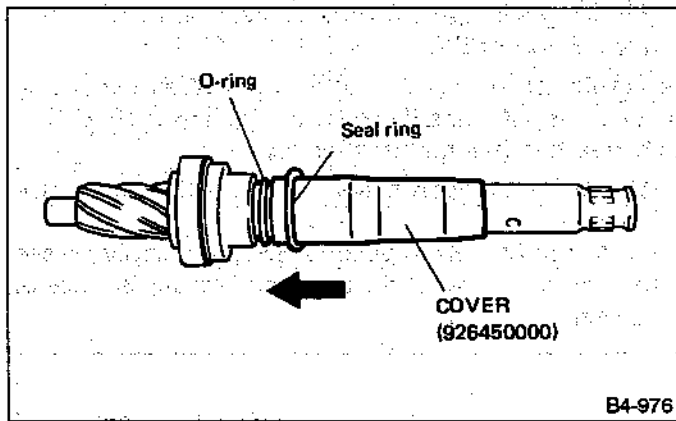


Fig. 82

(10) Apply a coat of grease to inner wall of FORMER, and secure seal ring assembled in step (9) as shown. Leave seal ring unattended for approximately 10 minutes until it settles down.

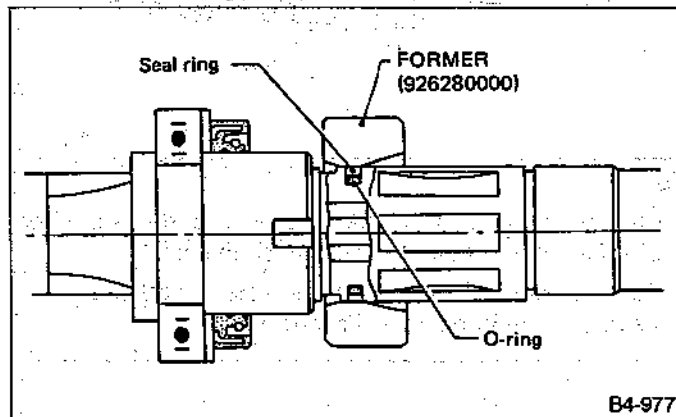


Fig. 83

(11) While aligning valve sleeve pin with groove on pinion ASSY, secure with snap ring.

- Be careful not to damage inner wall of valve sleeve and contact surface of pinion.
- Before assembling valve sleeve and pinion ASSY, clean in kerosene and dry with compressed air.

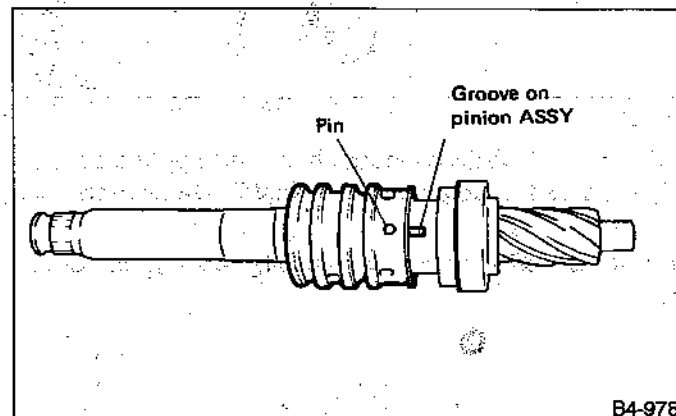


Fig. 84

2) Removal of rack piston seal ring and O-ring

(1) Using a sharp-edged, long rod, remove seal ring and O-ring from rack piston.

Be careful not to scratch outer surface of rack piston and seal ring groove. A scratch may reduce the sealing effect, resulting in faulty piston operation.

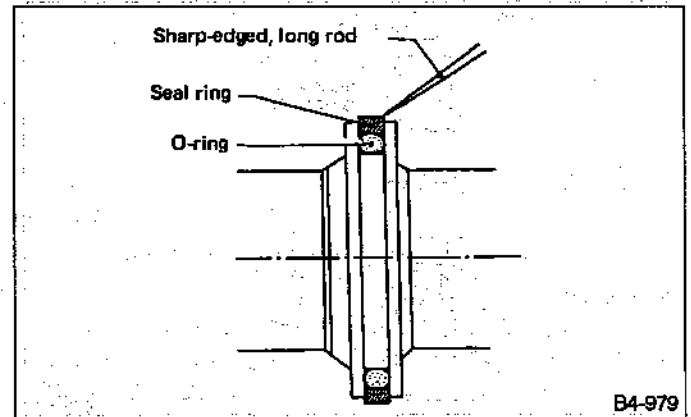


Fig. 85

(2) Wash clean rack piston.

(3) Install O-ring and seal ring in groove on rack piston.

- Do not expand O-ring and seal ring more than necessary.
- To facilitate installation of seal ring, first position one half of entire seal ring in groove. Then slowly position the second half using a spatula, as shown.

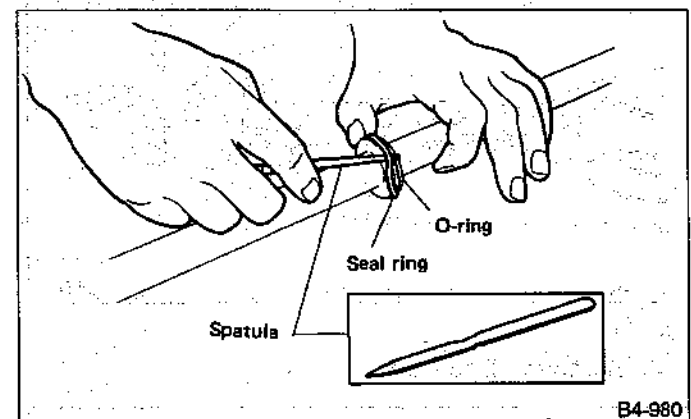
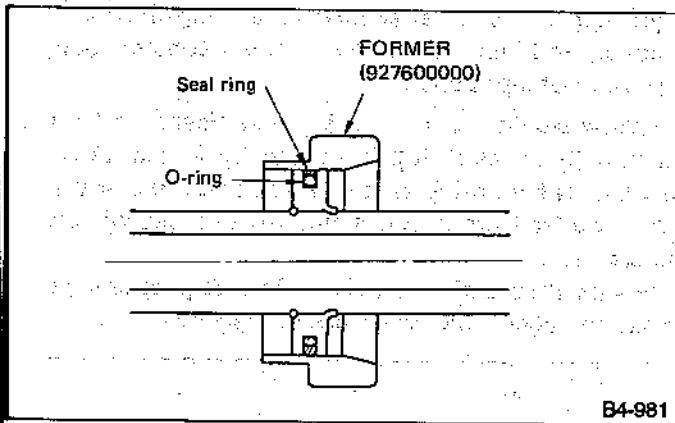


Fig. 86

(4) Apply a coat of grease to inner surface of FORMER (special tool) and insert rack piston into it. Leave FORMER at least 10 minutes until seal ring settles down in place.

Be careful not to scratch rack, piston and seal ring during installation.

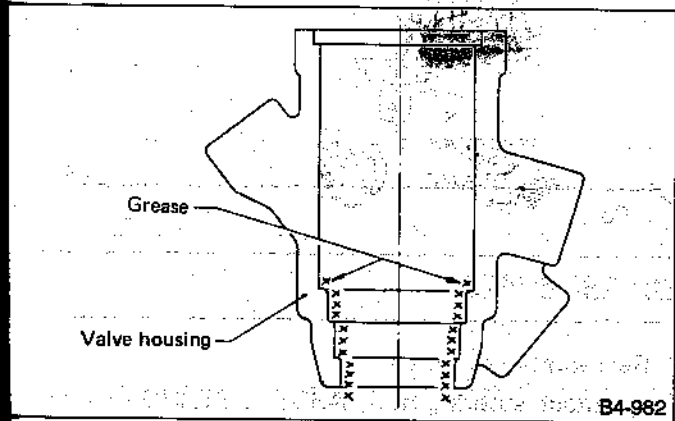


B4-981

Fig. 87

3) Reassembly of valve ASSY

(1) Apply a coat of grease to inner wall of valve housing, Y-packing and outer perimeter of dust seal.

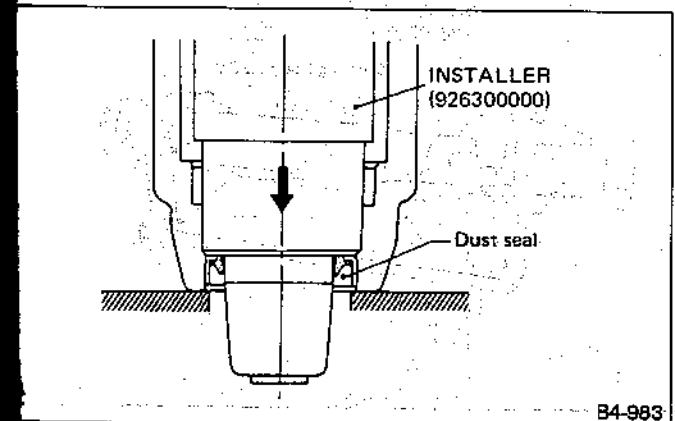


B4-982

Fig. 88

(2) Using INSTALLER and press, install dust seal.

Face dust seal in the direction shown in Figure 91. Apply a coat of grease to contact surface of installer and dust seal when installing dust seal. Be careful not to scratch dust seal during installation.

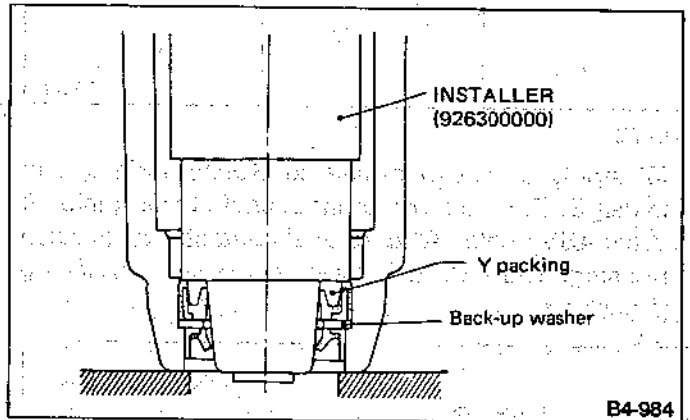


B4-983

Fig. 89

(3) Using INSTALLER and press, install Y-packing and back-up washer in valve housing.

- Face Y-packing in the direction shown in Figure 92 when installing.
- To avoid scratching Y-packing, apply a coat of grease to contact surface of installer and Y-packing.
- To facilitate installation, attach Y-packing and back-up washer to installer and position in valve housing before pressing into place.

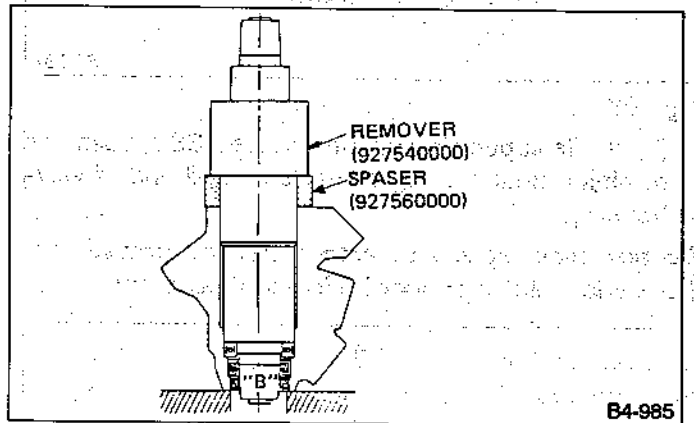


B4-984

Fig. 90

(4) Attach SPACER to REMOVER, and press ball bearing into place using a press.

- To facilitate installation, attach ball bearing to remover and position in valve housing before pressing it into place.
- Use the "B" end of remover.



B4-985

Fig. 91

(5) Charge dust seal with grease.

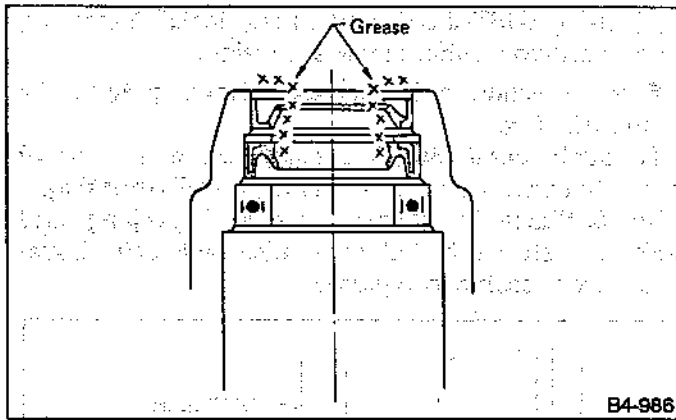


Fig. 92

(6) Apply a coat of grease to GUIDE surface, and install GUIDE onto end of input shaft. Insert pinion & valve ASSY until "A" of oil seal contacts "B" of valve housing. The GUIDE is used to prevent scratching Y-packing.

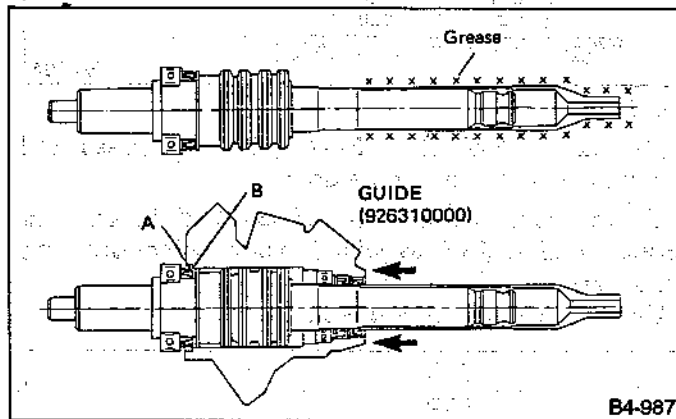


Fig. 93

(7) While supporting pinion & valve ASSY, push end of pinion until bearing contacts brazed end of valve housing.

Do not allow spacer to extend beyond brazed end. Otherwise, pinion cannot be inserted properly.

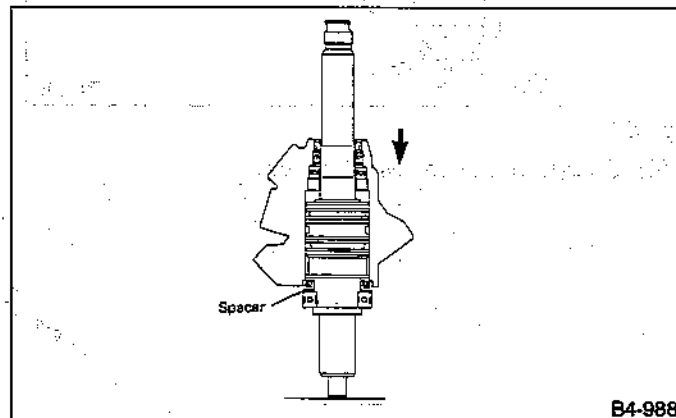


Fig. 94

(8) Apply a coat of grease to sealing lips of dust cover, and insert dust cover until it contacts staged portion of input shaft.

- Adjust sealing lip-to-housing end clearance to 0 to 0.5 mm (0 to 0.020 in). If sealing lip is too close to housing end, steering wheel will not return smoothly; if it is too far from housing end, dust or dirt will enter the clearance.
- Ensure that pinion & valve ASSY is properly positioned in valve housing before adjustment.

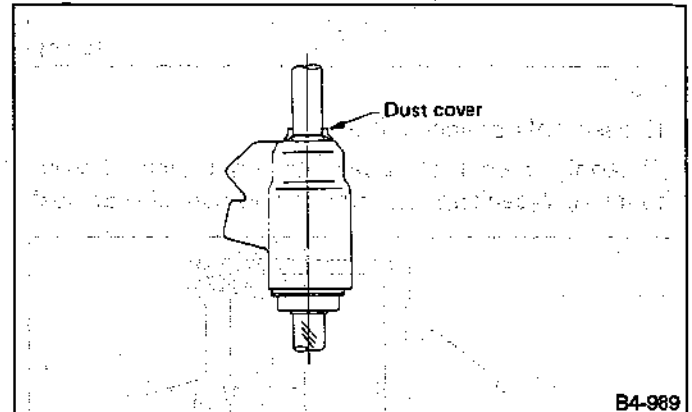


Fig. 95

D: ASSEMBLY

1) Reassembly of rack ASSY

(1) Attach steering body ASSY to STAND as shown. Apply a coat of grease to needle bearing.

- Use a special tool to support steering body ASSY.
- If steering body ASSY is removed from vehicle, be sure to remove rust and clean.
- Ensure that needle bearing is free from defects. If it is faulty, replace steering body ASSY with a new one.

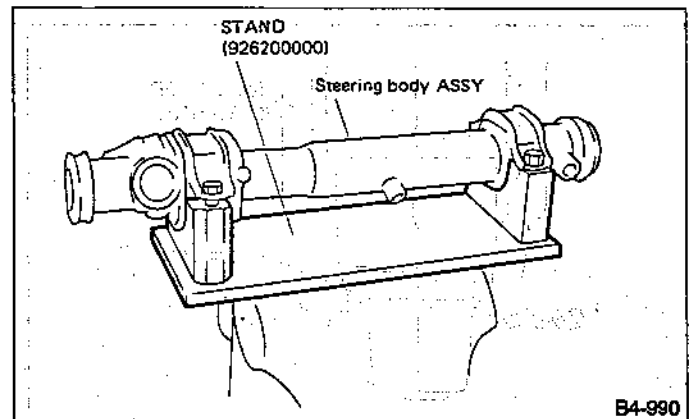


Fig. 96

(2) Using INSTALLERS B and C, attach oil seal to INSTALLER A. Insert INSTALLER A into rack ASSY from gear side. Remove oil seal from INSTALLER A when it approaches piston and remove INSTALLERS from rack ASSY.

Face oil seal in the direction shown in Figure 97.

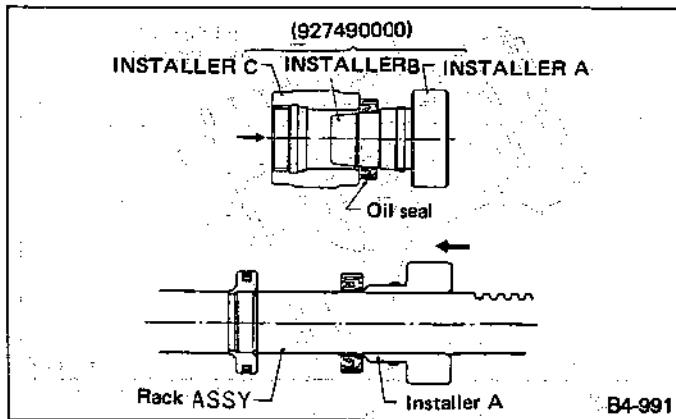


Fig. 97

(3) Install back-up ring from gear side of rack ASSY.

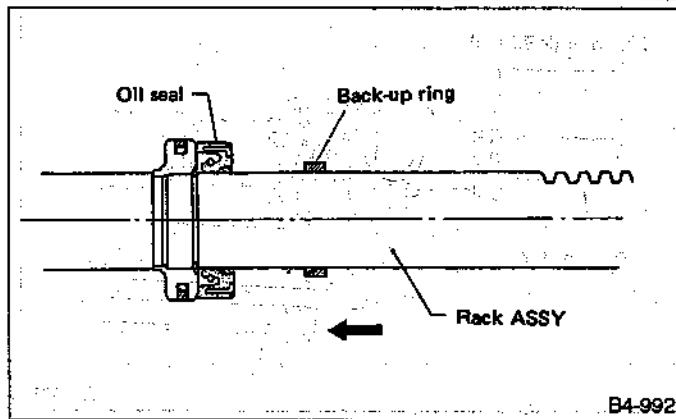


Fig. 98

(4) Apply a coat of grease to grooves in rack, sliding surface of sleeve and sealing surface of piston. Then insert rack ASSY into steering body ASSY from cylinder side.

- Be sure to apply grease so that it covers the entire surface of rack gear teeth.
- Do not allow grease to block air vent hole on rack.

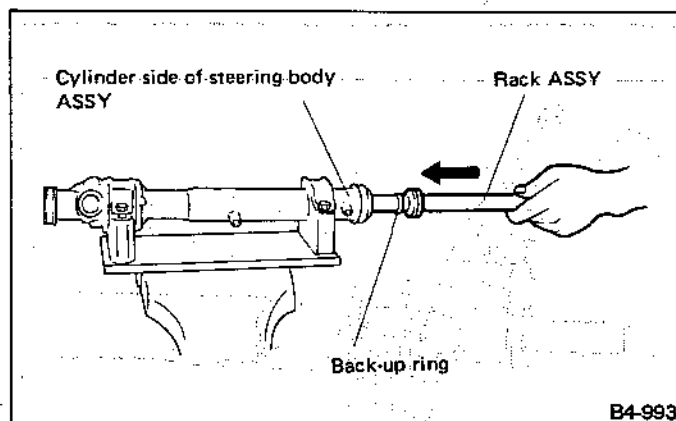


Fig. 99

(5) Installation of holder ASSY -

Attach GUIDE to rack ASSY to prevent scratching cylinder, and apply a thin coat of grease to rack ASSY and GUIDE.

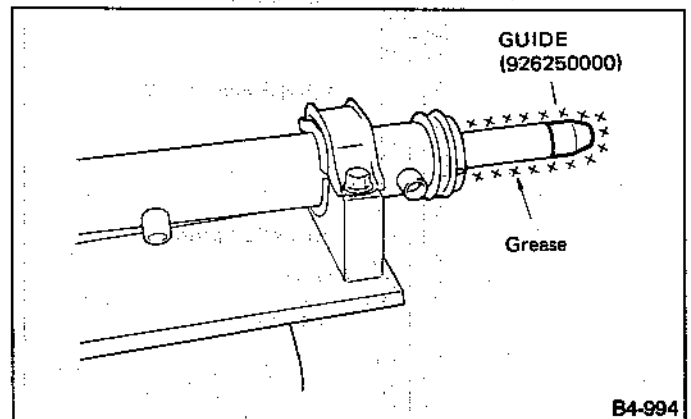


Fig. 100

(6) Apply a coat of grease to inner wall of holder ASSY and O-ring, and install holder ASSY on steering body ASSY.

- Ensure that guide is free from scratches. Scratches may damage Y-packing.
- Be careful not to damage Y-packing lips when installing holder ASSY.

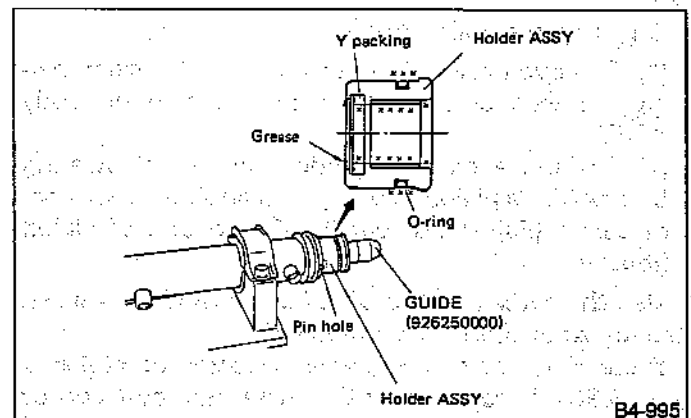


Fig. 101

(7) Apply a coat of grease to snap ring, and insert into groove in steering body ASSY. Secure holder ASSY.

Ensure that both ends of snap ring are close to pin hole when installed.

(8) Attach INSTALLER to rack ASSY's cylinder. Using a press, install back-up ring and oil seal.

Press INSTALLER until its groove is aligned with end of holder ASSY.

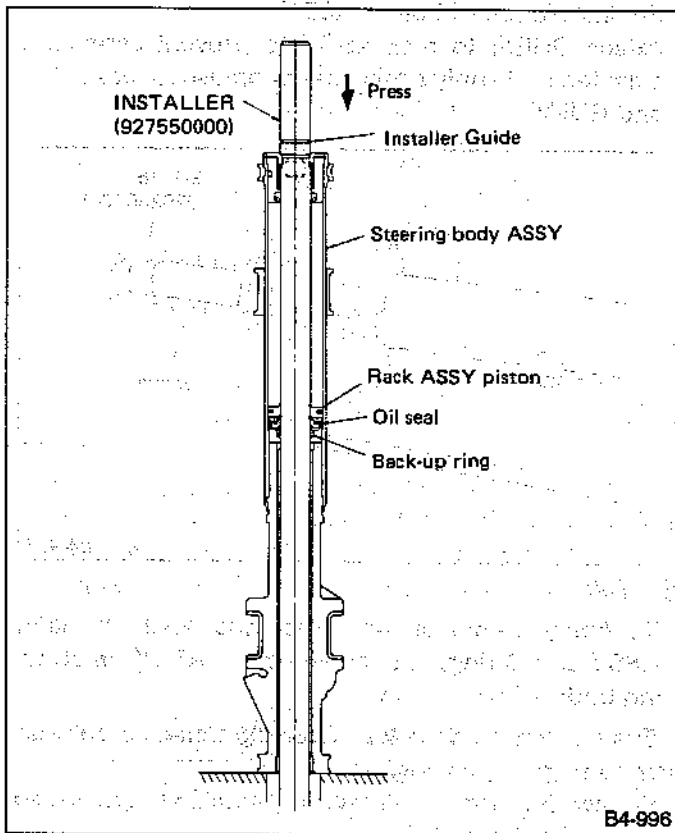


Fig. 102

2) Installation of valve ASSY

(1) Remove traces of sealer, oil, rust, etc., from mating surfaces of valve housing and steering body ASSY.

(2) Position a shim in graded portion of steering body ASSY's pinion housing, and apply an even coat of sealer (Fuji Bond; 004403004) to end of pinion housing.

- Use the same number of shims as that used when steering body ASSY was removed.

- If steering body ASSY, valve housing or pinion & valve ASSY is replaced with a new one, add two or three shims, install valve ASSY on pinion housing and tighten with two bolts to 20 — 29 N·m (2.0 — 3.0 kg-m, 14 — 22 ft-lb). Then, measure clearance between steering body ASSY and valve housing using a thickness gauge. Remove shims so that the clearance is zero.

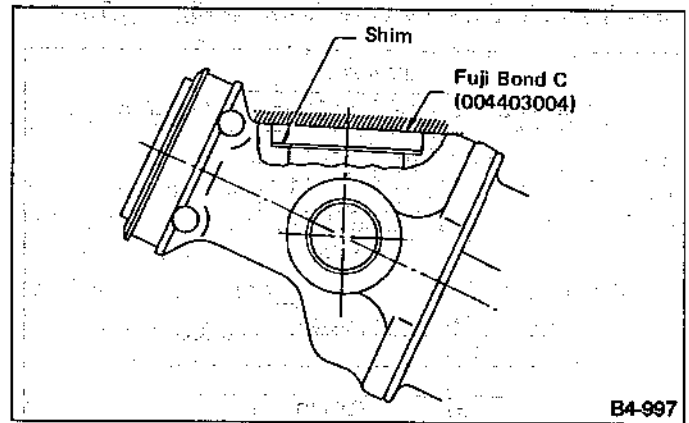


Fig. 103

(3) Extend rack ASSY 72.4 mm (2.850 in) beyond pinion side of steering body ASSY.

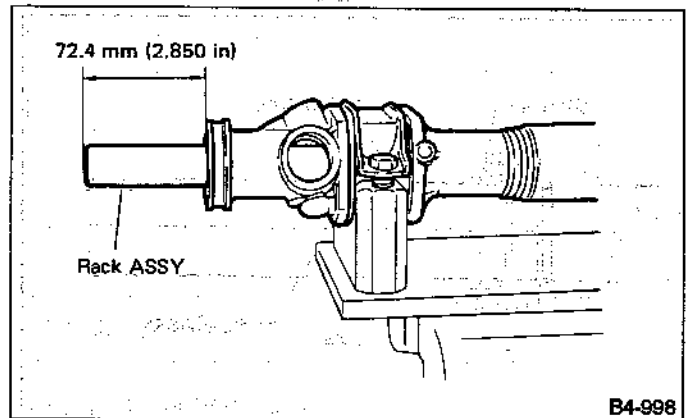


Fig. 104

(4) Apply grease to pinion gear teeth and ball bearing. Insert valve ASSY into place.

(5) Alternately and slowly tighten socket bolts.

Replace faulty parts before installing valve ASSY. Otherwise, valve ASSY may not be installed properly.

Tightening torque:

20 — 29 N·m (2.0 — 3.0 kg-m, 14 — 22 ft-lb)

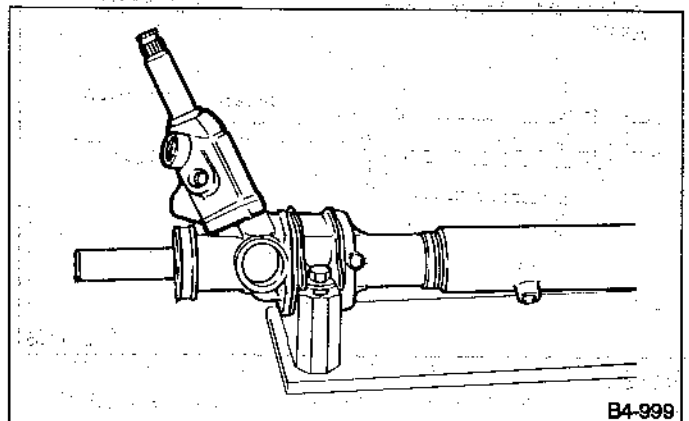


Fig. 105

5. Hose ASSY (Power Steering System)

A: REMOVAL

- 1) Disconnect battery minus terminal.
- 2) Lift vehicle and remove jack-up plate.

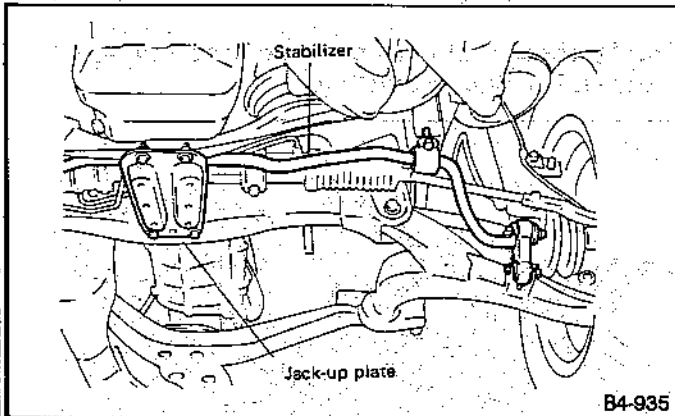


Fig. 106

- 3) Disconnect one pipe and joint from center of gearbox ASSY, and connect a vinyl hose to them. While turning the steering wheel to the left and right, drain fluid through the hose. Similarly, drain fluid from the other pipe and joint line.

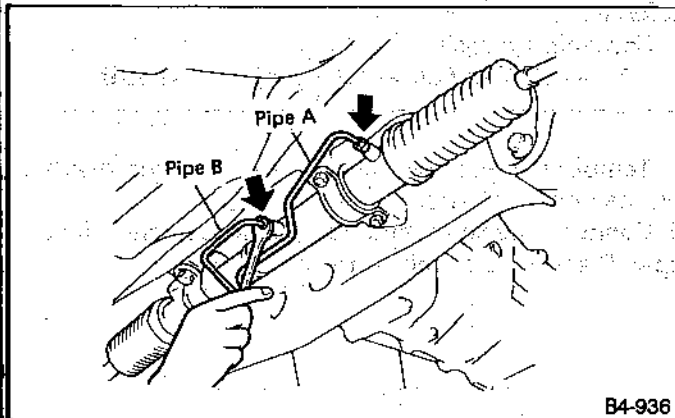


Fig. 107

- 4) Remove flare nuts from control valve of gearbox ASSY, and disconnect upper and lower hoses A and B.

- Always disconnect hose A and hose B in that order.
- Be careful not to damage the hoses during removal.

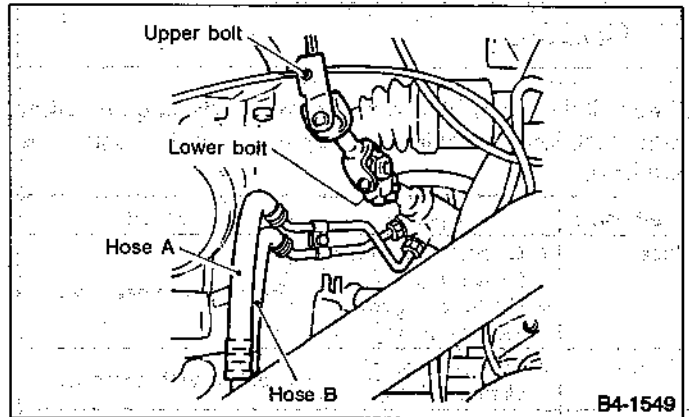


Fig. 108

- 5) Remove bolt A. Disconnect pipe C from oil pump. Disconnect pipe D from oil tank.

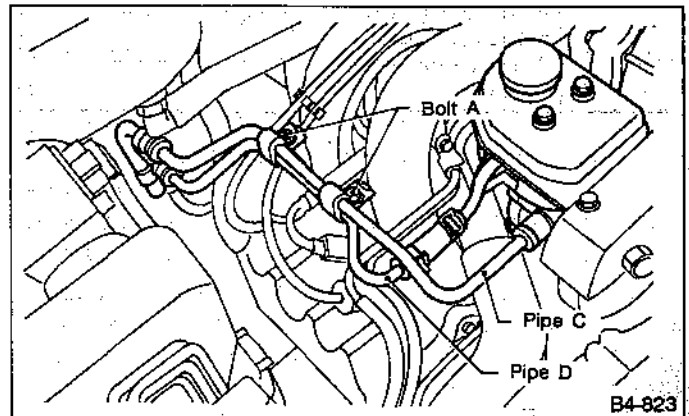


Fig. 109

- a. Do not allow fluid from the hose end to come into contact with pulley belt.
- b. To prevent foreign matter from entering the hose and pipe, cover the open ends of them with a clean cloth.

B: CHECK

Check all disassembled parts for wear, damage or other abnormalities. Repair or replace faulty parts as required.

Part name	Inspection	Remedy
Pipe	<ul style="list-style-type: none"> • O-ring fitting surface for damage • Nut for damage • Pipe for damage 	Replace with new one.
Clamp	<ul style="list-style-type: none"> • Clamps for weak clamping force 	Replace with new one.
Hose	<ul style="list-style-type: none"> • Flared surface for damage • Flare nut for damage • Outer surface for cracks • Outer surface for wear • Clip for damage • End coupling or adapter for degradation 	Replace with new one.

C: ASSEMBLY

1) Interconnect pipes C and D.

Tightening torque:

Joint nut

10 — 20 N·m (1.0 — 2.0 kg-m, 7 — 14 ft-lb)

Visually check that hose between tank and pipe D is free from bending or twisting.

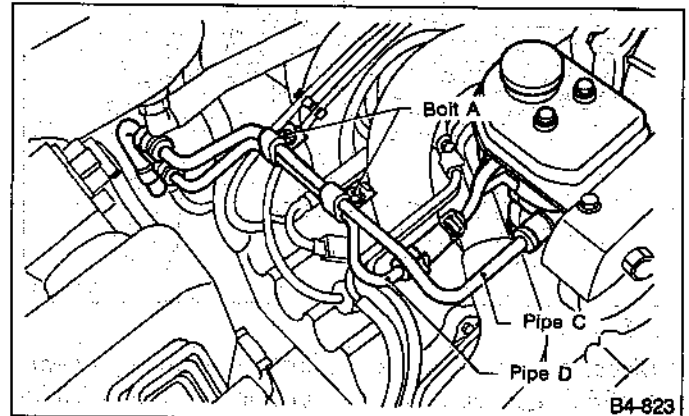


Fig. 110

2) Tighten bolt A.

Reference

Tightening torque:

10 — 16 N·m (1.0 — 1.6 kg-m, 7 — 12 ft-lb)

3) Temporarily connect pipes C and D to the gearbox (on the gearbox side).

4) Connect pressure and return hoses, and tighten pipes C and D to specified torque.

6. Oil Pump (Power Steering System)

A: REMOVAL

- 1) Remove ground cable from battery.
- 2) Remove belt cover.
- 3) Loosen slider bolt lock nut. Loosen slider bolt, and remove V-belt while lowering alternator.

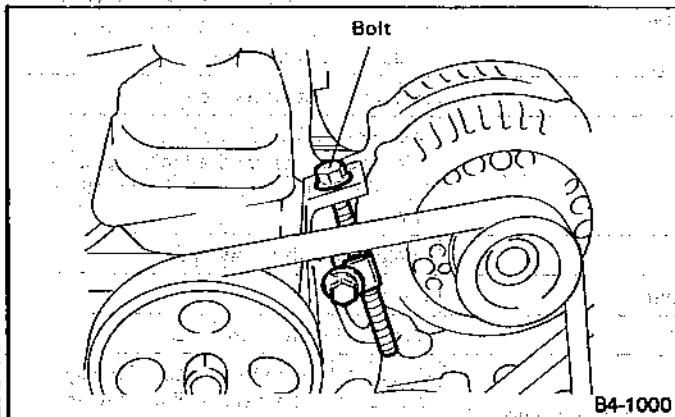


Fig. 111

- 4) Remove nut from front end of oil pump pulley, and detach oil pulley.

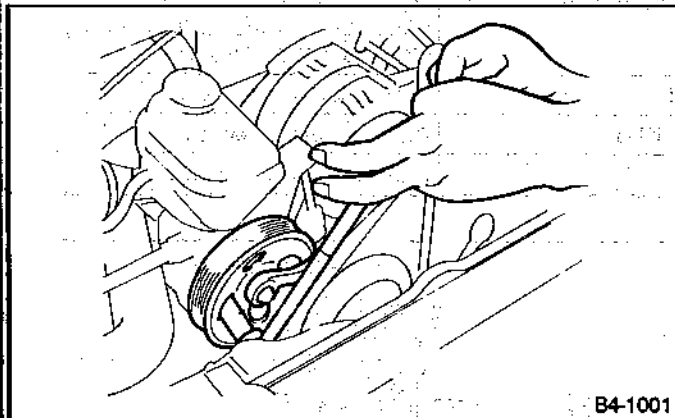


Fig. 112

- 5) Drain approximately 0.3 liters (0.3 US qt, 0.3 Imp qt) of fluid from oil tank.

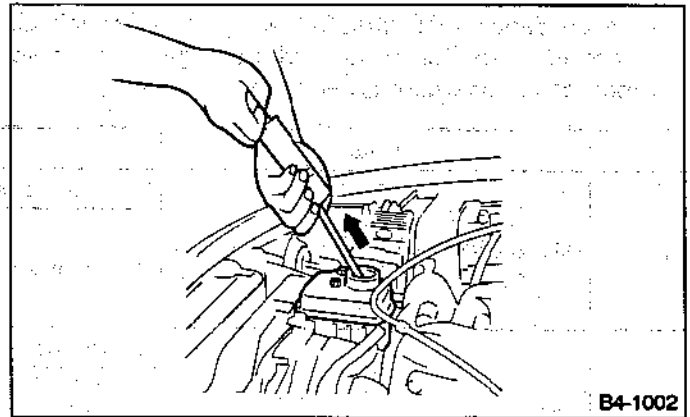


Fig. 113

- 6) Disconnect hose A from pump.
 - 7) Disconnect hose B from oil tank.
- Be careful not to spill fluid from hose end to V-belt.
 - Cover open ends of hose and pipe with a clean cloth to prevent entry of foreign matter.
- 8) Remove bolts from front of pump, and detach pump and tank.
 - 9) Place pump in a vise, and remove bolts from upper surface of tank.
- Use soft jaws and lightly tighten vise jaws.
 - After bolts are loose enough to be rotated with your hand, press pump against tank while removing bolts. Failure to do so causes fluid to spill out. Remove tank as quickly as possible, and wipe clean fluid spilled on parts. Except when only tank is to be checked, remove tank and pump as a unit and separate from each other on a work bench. This prevents fluid from spilling on the engine.

B: CHECK

- In accordance with the following table, check all removed parts for wear and damage, and make repair or replacement if necessary.

No.	Parts	Inspection	Corrective action
1	Oil pump (Outside)	(1) Crack, damage or oil leakage	Replace oil pump ASSY with a new one.
		(2) Play of pulley shaft	Measure radial play and axial play. If any of these exceeds the service limit, replace oil pump ASSY with a new one. (Refer to "Service limit".)
2	Pulley	(1) Damage	Replace it with a new one.
		(2) Bend	Measure V ditch deflection. If it exceeds the service limit, replace pulley with a new one. (Refer to "Service limit".)
3	Cap	Crack or damage	Replace it with a new one.
4	Strainer	(1) Clogging with dirt	Wash it.
		(2) Breakage	Replace it with a new one.
5	Oil pump (Interior)	(1) Defect or burning of vane pump	Check resistance to rotation of pulley. If it is past the service limit, replace oil pump ASSY with a new one. (Refer to "Service limit".)
		(2) Bend in the shaft or damage to bearing	Oil pump emits a noise that is markedly different in tone and loudness from a sound of a new oil pump when turning with a string put around its pulley, replace oil pump ASSY with a new one.
6	O-ring	Crack or deterioration	Replace it with a new one.
7	Oil tank	Crack, damage or oil leakage	Replace it with a new one.
8	Bracket	Crack	Replace it with a new one.

1. SERVICE LIMIT

Make a measurement as follows. If it exceeds the specified service limit, replace the parts with a new one.

a. Fix oil pump ASSY on a vise to make a measurement. At this time, hold oil pump ASSY with the least possible force between two wood pieces.

b. Do not set outside of flow control valve or pulley on a vise; otherwise outside of pulley might be deformed. Select properly sized wood pieces.

Play of pulley shaft

Service limit:

Radial play (Direction \longleftrightarrow)

0.4 mm (0.016 in) or less

Axial play (Direction \leftrightarrow)

0.9 mm (0.035 in) or less

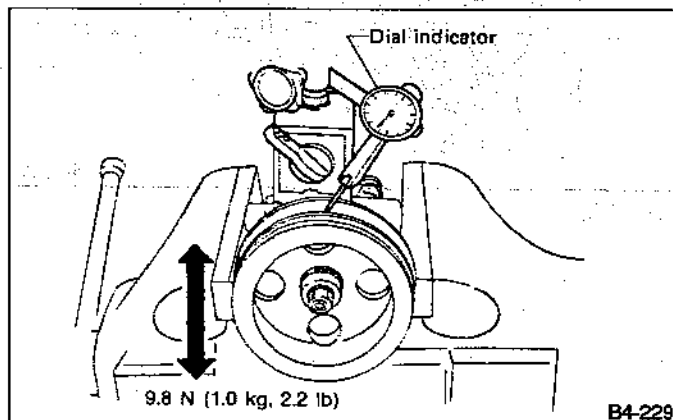
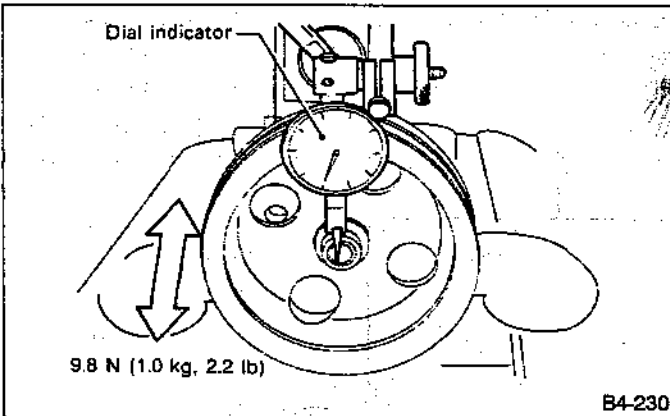


Fig. 114 Radial play



**Fig. 115 Axial play
Ditch deflection of pulley**

**Service limit:
1.0 mm (0.039 in) or less**

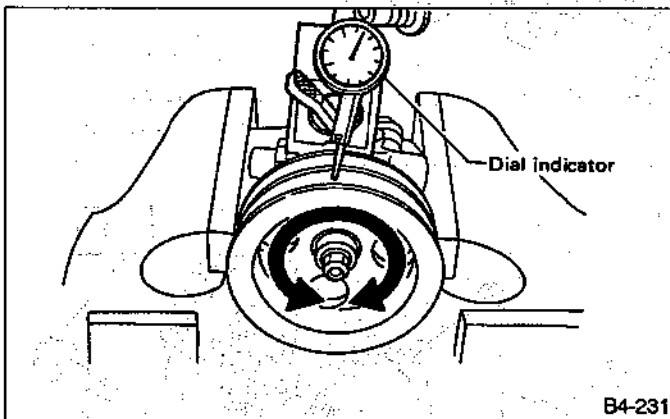


Fig. 116

Read the value for one surface of V ditch, and then the value for another off the dial.

Resistance to rotation of pulley

Service limit:

Maximum load; 9.22 N (0.94 kg, 2.07 lb) or less

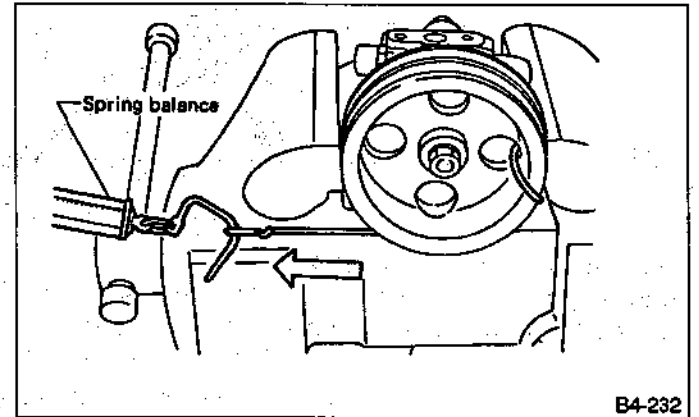


Fig. 117

A rather higher value may be indicated when pulley starts turning.

Measure the load during rotation and make a judgment.

C: DISASSEMBLY

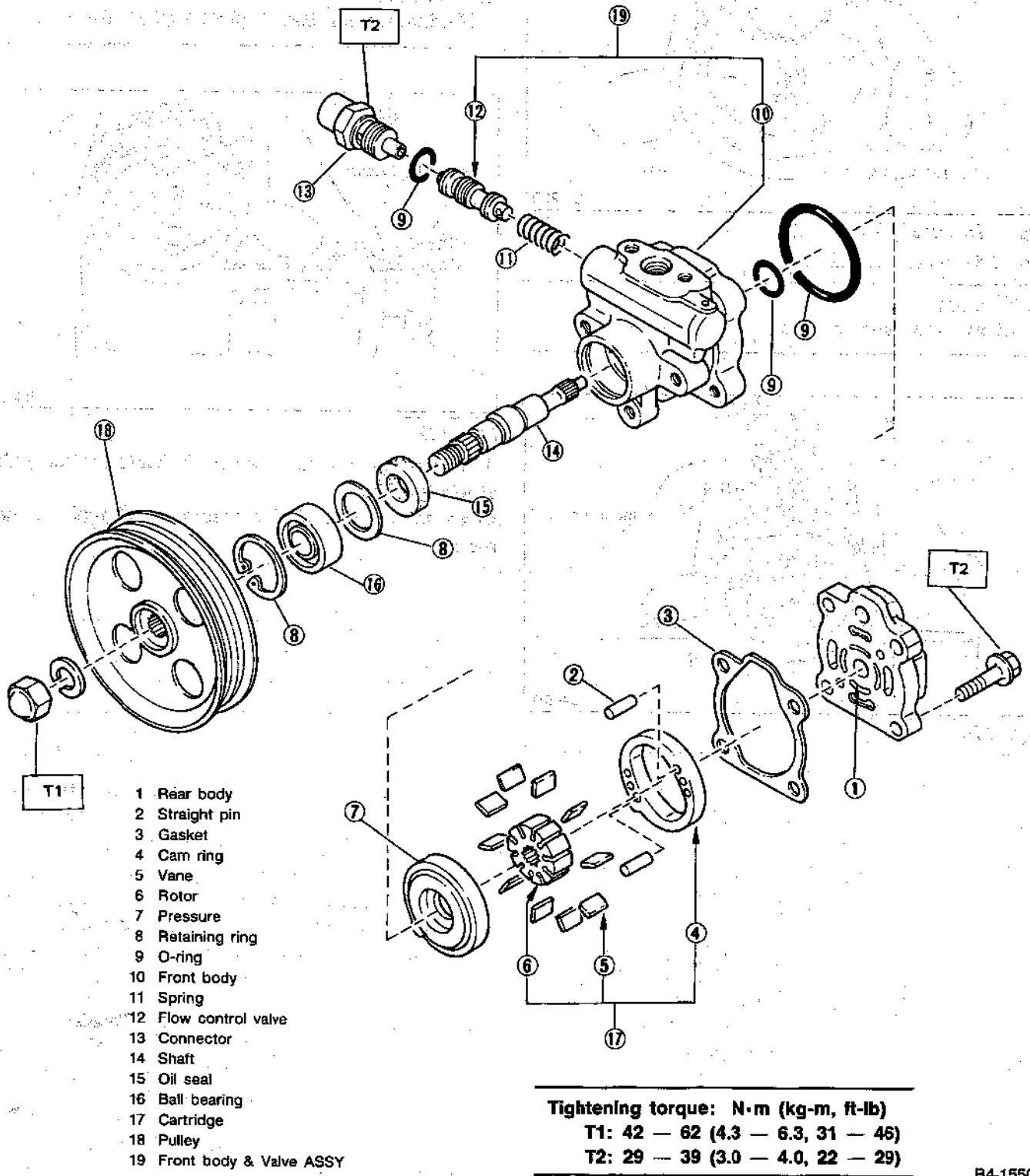


Fig. 118

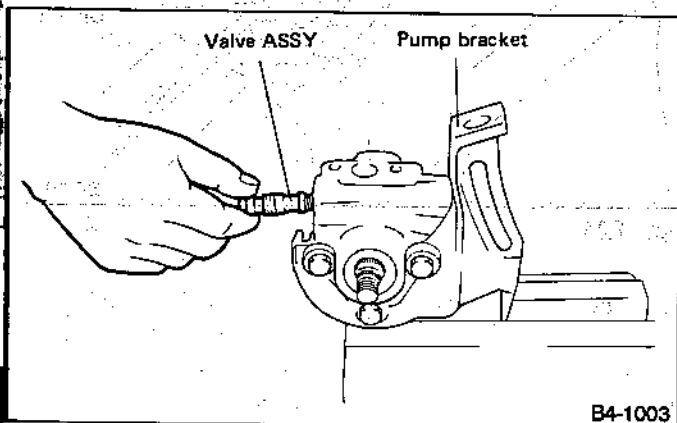
B4-1550

1) Place pump bracket (with pump installed) in a vise using soft jaws.

• Do not place pump itself in a vise.

2) Valve removal

Disconnect connectors and remove valve ASSY and spring.

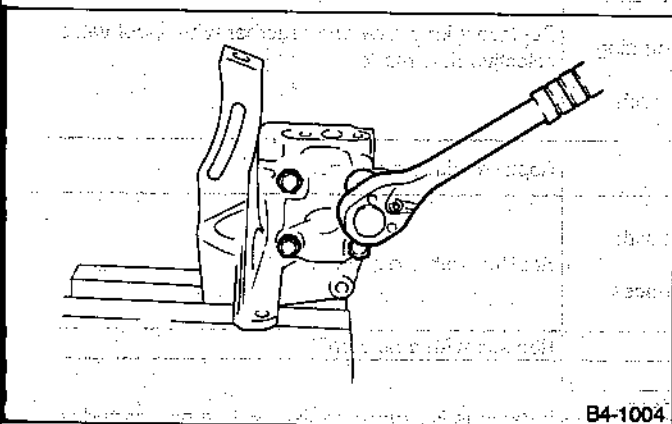


B4-1003

Fig. 119

3) Rear body removal

(1) Loosen bolts securing rear body so that they can be rotated by hand.



B4-1004

Fig. 120

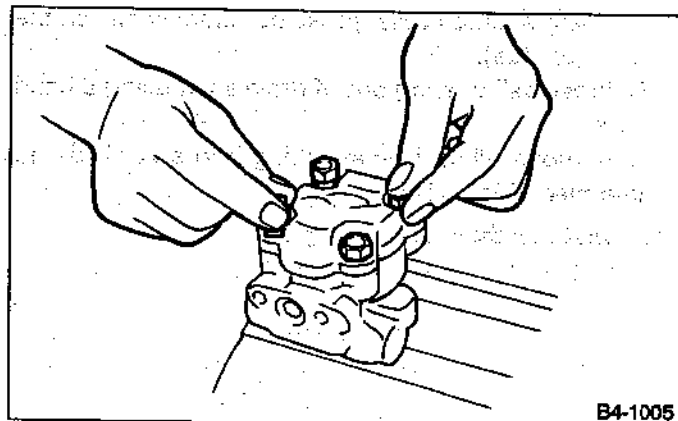
(2) Remove pump from pump bracket.

(3) Remove pump bracket from vise.

(4) Place pump in a vise.

Use soft jaws.

(5) Remove bolts which have already been loosened in step (1) above.



B4-1005

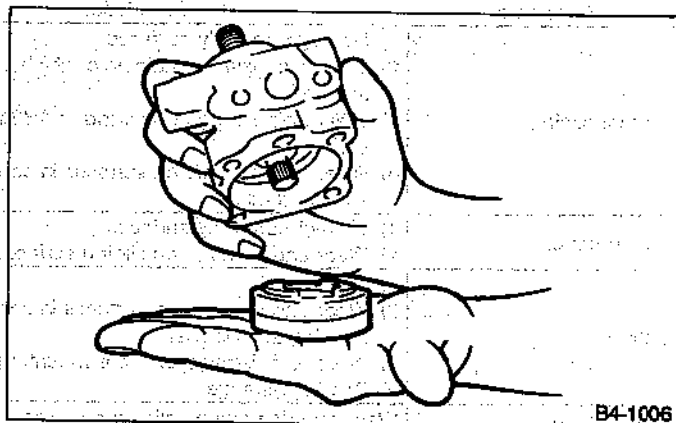
Fig. 121

(6) Remove gasket.

4) Removal of cartridge ASSY, pressure plate and pin
Remove cartridge ASSY, pressure plate and pin from front body as a unit. (Cartridge ASSY consists of a rotor, ten vanes and a cam.)

Be careful not to scratch cartridge ASSY.

5) Remove two types of O-rings by hand.

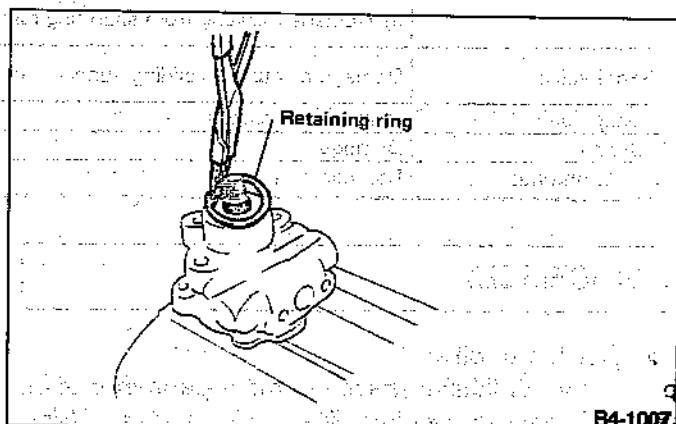


B4-1006

Fig. 122

6) Disassembly of front body

(1) Pry off retaining ring from inner perimeter groove of front body at pulley location.



B4-1007

Fig. 123

- (2) Using a hand press, press out drive shaft (on the cartridge side).
- (3) Press ball bearing out of drive shaft using a hand press.
- (4) Remove oil seal by attaching it to a hooked-end plate placed in a vise.

Use a plate without sharp edges.

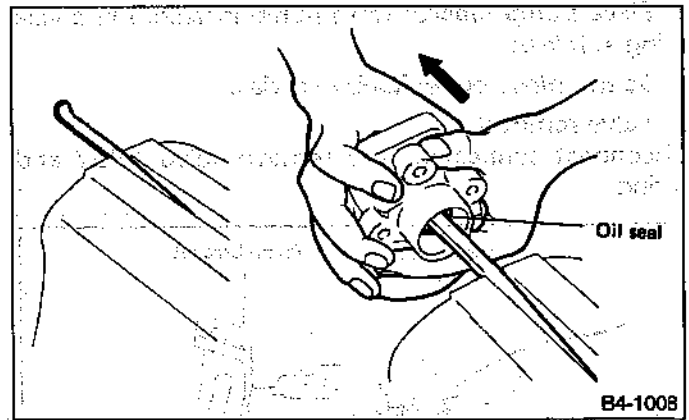


Fig. 124

D: INSPECTION

Perform following inspection procedures and repair or replace defective parts.

Part name	Description	Remedy
1. Front casing	<ol style="list-style-type: none"> 1) Damage on body surfaces 2) Excessive wear on hole, into which spool valve is inserted. 3) Wear and damage on cartridge ASSY mounting surface 4) Wear and damage on surfaces in contact with shaft and oil seal 	Replace with a new one together with spool valve as selective fit is made.
2. Rear cover	<ol style="list-style-type: none"> 1) Damage on body surfaces 2) Wear and damage on sliding surfaces 	Replace with a new one.
3. Shaft	<ol style="list-style-type: none"> 1) Shaft bend 2) Wear and damage on surfaces in contact with bushing and oil seal 3) Wear and damage on rotor mounting surfaces 4) Bearing damage 	Replace with a new one.
4. Side plate	Wear and damage on sliding surfaces	Replace with a new one.
5. Cam ring	Ridge wear on sliding surfaces	If damage is serious, replace with a new cartridge ASSY.
6. Vane	Excessive wear on nose radius and side surfaces	
7. Rotor	<ol style="list-style-type: none"> 1) Wear and damage on sliding surfaces 2) Ridge wear on vane sliding grooves (If light leaks with vane in slit against light source) 3) Damage resulting from snap ring removal 	Correct with oil stone. If damage is serious, replace with a new cartridge ASSY.
8. Spool valve	Damage or burrs on sliding surface periphery	Replace with a new one together with front casing as selective fit is made.
9. Connector	Damage on threads	Replace with a new one.
10. Spring	Damage	Replace with a new one.
11. Bolts and nuts	Damage on threads	Replace with a new one.

E: ASSEMBLY

1) Installation of oil seal

Apply a coat of lithium grease to outer perimeter of oil seal and charge sealing lips with grease. Using INSTALLER and a hand press, press oil seal into front body.

Place the seating surface of front body on a soft cloth to prevent it from sustaining scratches while pressing oil seal into place.

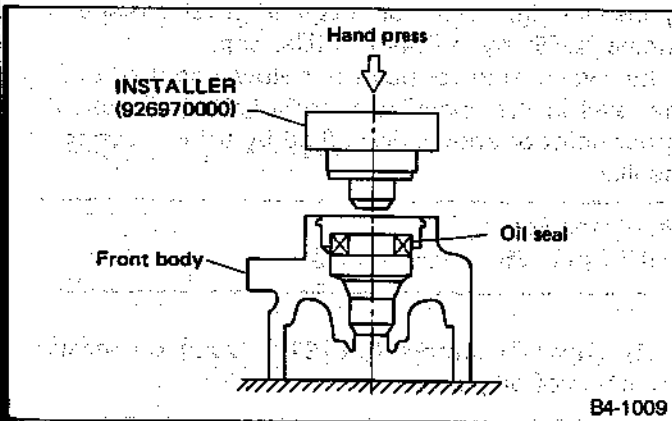


Fig. 125

2) Installation of drive shaft

(1) Using GUIDE and a hand press, drive bearing onto shaft.

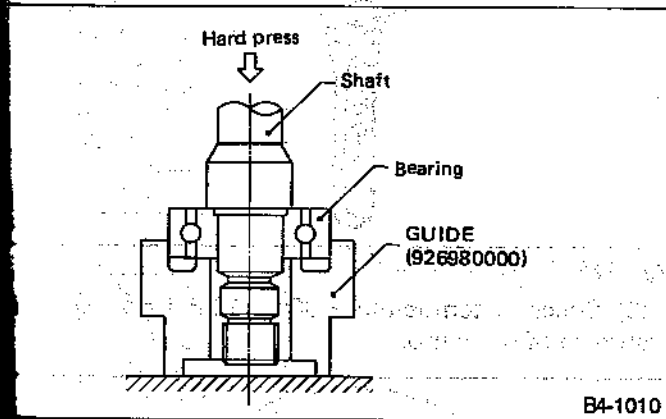
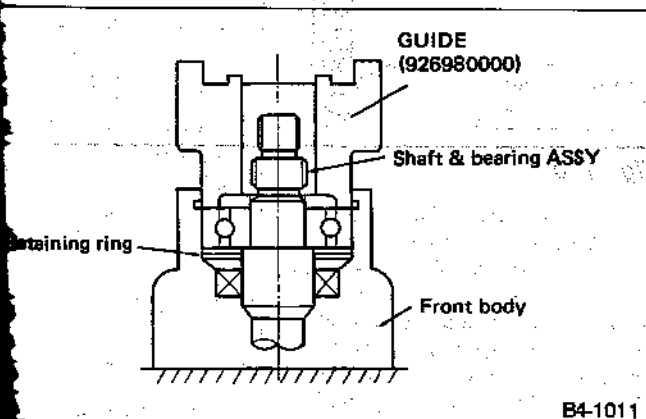


Fig. 126

(2) Install retaining ring on oil seal. Using GUIDE, press shaft & bearing ASSY into front body.

Be careful not to strike shaft splines on oil seal's sealing lips during installation.
Do not hit end of shaft during installation.



127

3) Lock drive shaft using a retaining ring.
Installation of pressure plate

Place front body in a vise with pulley side facing down. Position two O-rings and pressure plate in front body in that order.

Do not forget to install O-rings.

4) Installation of cartridge

- (1) Install cam, rotor and vane in that order.
- (2) Insert pin into holes in cam and pressure plate.

• Ensure that vane is installed with "R" side facing the cam.

• Check that vane moves smoothly.

• Apply a coat of automatic transmission fluid (DEXRON II) to vane.

5) Installation of rear body

- (1) While aligning pin hole of rear body with pin on the pump, install rear body using a gasket and tighten bolts by hand.
- (2) Remove pump from vise.
- (3) Place pump bracket in a vise, install pump on pump bracket.
- (4) Tighten rear body mounting bolts in a criss-cross fashion to one-half of specified torque, then tighten to specified torque.

After tightening rear body mounting bolts, ensure that shaft rotates properly.

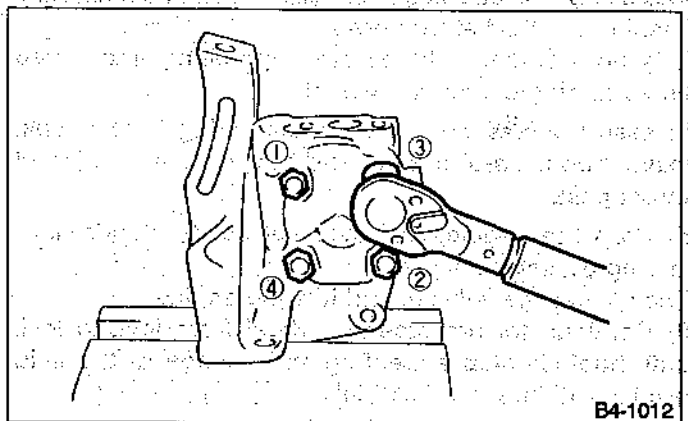


Fig. 128

6) Installation of valve

- (1) Position spring and valve ASSY in front body in that order.
- (2) Connect connector to front body with an O-ring in place.

Tightening torque:

29 — 39 N·m (3.0 — 4.0 kg-m, 22 — 29 ft-lb)

F: INSTALLATION

To install, reverse the order of removal procedures. Replenish specified fluid and purge air.

Do not operate engine before replenishing fluid as this will seize oil pump.

G: RECOMMENDED POWER STEERING FLUID

Recommended power steering fluid	Manufacturer
ATF DEXRON II	B.P.
	CALTEX
	CASTROL
	MOBIL
	SHELL
	TEXACO

- 1) Feed the specified fluid with its level being about 4 cm (1.6 in) lower than the mouth of tank.
- 2) Continue to turn steering wheel slowly from lock to lock until bubbles stop appearing in the tank while keeping the fluid at that level.

In case air is absorbed to deliver bubbles into piping because the fluid level is lower, leave it about half an hour and then do the step (2) all over again.

- 3) Start, and idle the engine.
- 4) Continue to turn steering wheel slowly from lock to lock again until bubbles stop appearing in the tank while keeping the fluid at that level.

It is normal that bubbles stop appearing after three times turning of steering wheel.

In case bubbles do not stop appearing in the tank, leave it about half an hour and then do the step (4) all over again.

- 5) Stop the engine, and take out safety stands after jacking up vehicle again. Then lower the vehicle, and idle the engine.
- 6) Continue to turn steering wheel from lock to lock until bubbles stop appearing and change of the fluid level is within 3 mm (0.12 in).

In case the following happens, leave it about half an hour and then do step (6) again.

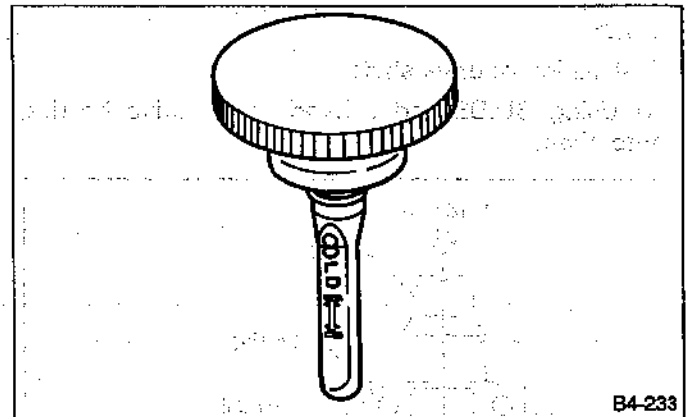
- a. The fluid level changes over 3 mm (0.12 in).
 - b. Bubbles remain on the upper surface of the fluid.
 - c. Grinding noise is generated from oil pump.
- 7) Check the fluid leakage at flare nuts after turning steering wheel from lock to lock with engine running.
 - a. Before checking, wipe off any fluid on flare nuts and piping.
 - b. In case the fluid leaks from flare nut, it is caused by dust (or the like) and/or damage between flare and tapered seat in piping.

So remove the flare nut, tighten again it to the specified torque after cleaning flare and tapered seat. If flare or tapered seat is damaged, replace it with a new one.

- 8) Inspect fluid level on flat and level surface with engine "OFF" by indicator of filler cap. If the level is at lower point or below, add fluid to keep the level in the specified range of the indicator. If at upper point or above, drain fluid by using a syringe or the like.

Fluid capacity:
0.7 l (0.7 US qt, 0.6 Imp qt)

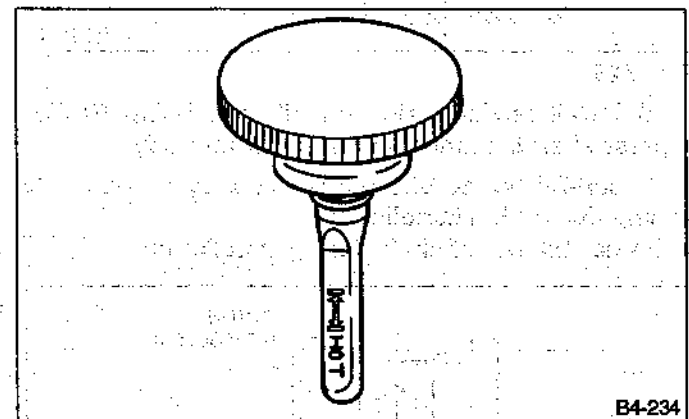
- (1) Check at temperature 21°C (70°F) on reservoir surface of oil pump.



B4-233

Fig. 129

- (2) Check at temperature 60°C (140°F) on reservoir surface of oil pump.



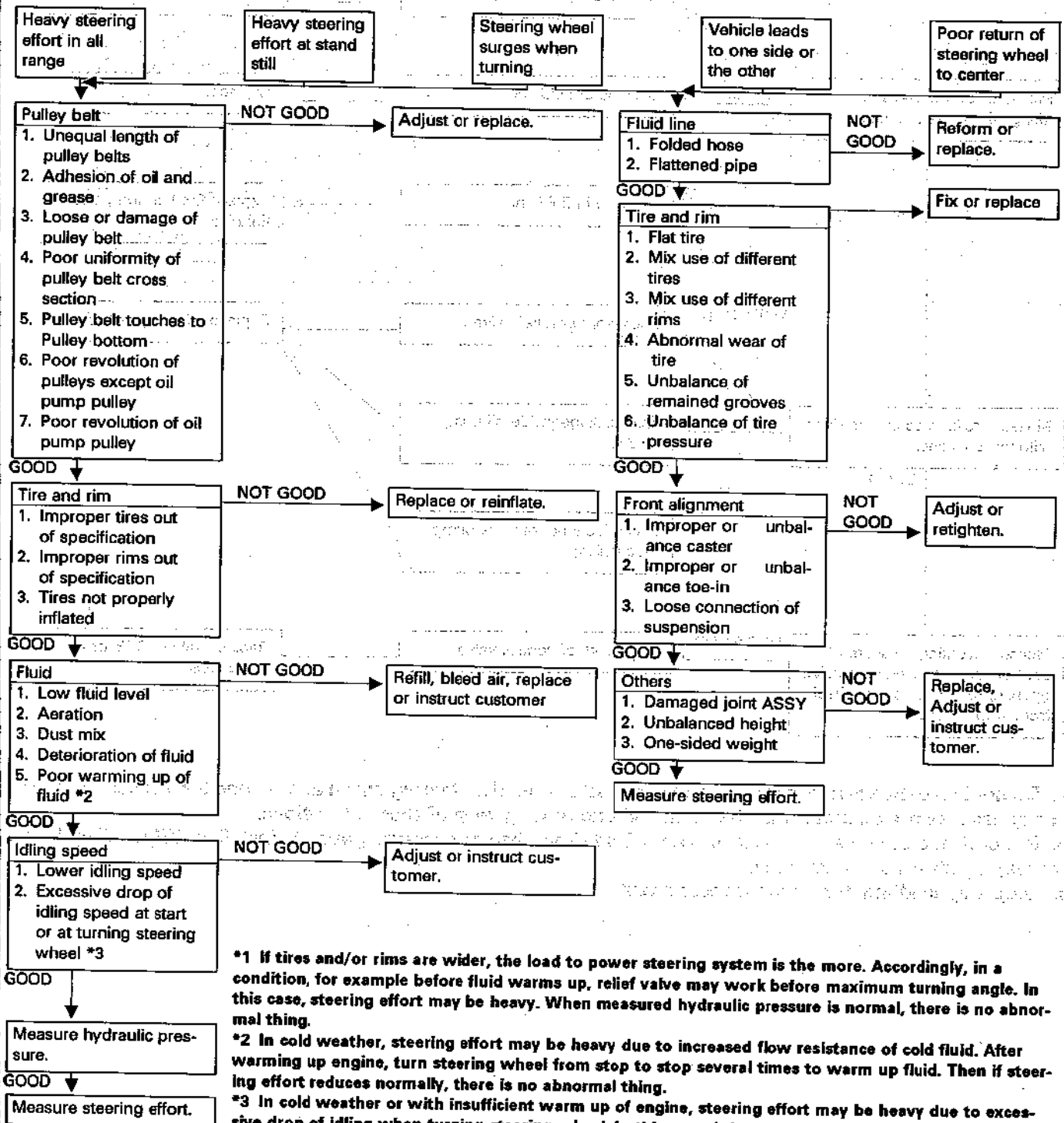
B4-234

Fig. 130

T TROUBLESHOOTING

1. Power Steering

1. STEERING CONDITION



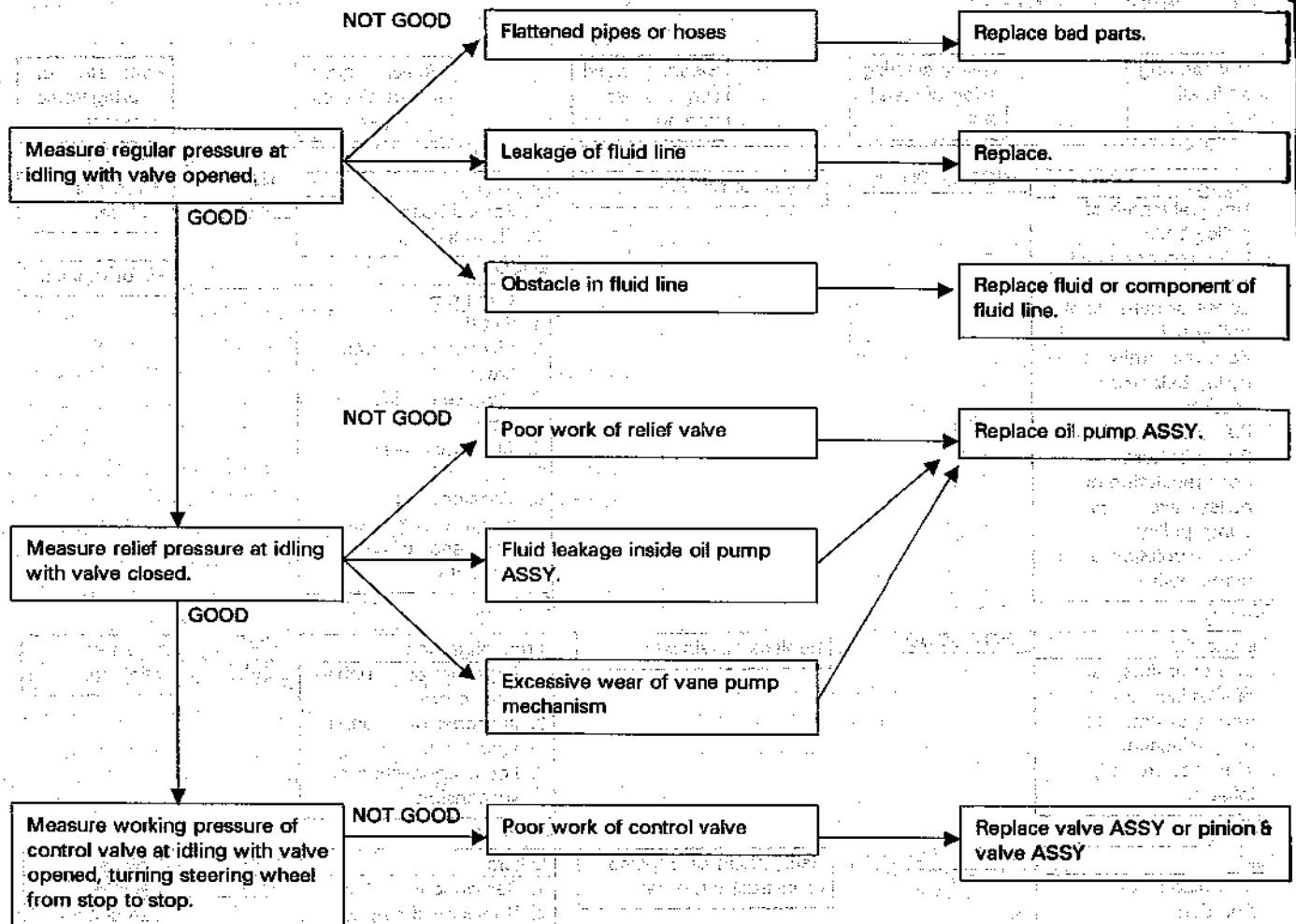
*1 If tires and/or rims are wider, the load to power steering system is the more. Accordingly, in a condition, for example before fluid warms up, relief valve may work before maximum turning angle. In this case, steering effort may be heavy. When measured hydraulic pressure is normal, there is no abnormal thing.

*2 In cold weather, steering effort may be heavy due to increased flow resistance of cold fluid. After warming up engine, turn steering wheel from stop to stop several times to warm up fluid. Then if steering effort reduces normally, there is no abnormal thing.

*3 In cold weather or with insufficient warm up of engine, steering effort may be heavy due to excessive drop of idling when turning steering wheel. In this case, it is recommended to start the vehicle with increasing engine speed than usual. Then if steering effort reduces normally, there is no abnormal thing.

2. MEASUREMENT OF HYDRAULIC PRESSURE

Be sure to complete all items aforementioned in article 1), prior to measuring hydraulic pressure. Otherwise pressure can not be measured correctly.



- Do not leave the valve of pressure gauge closed or hold the steering wheel at stop end for 5 seconds or more in any case, as the oil pump may be damaged due to long keep of these conditions.
- Put cotton cloth waste at a place where fluid drops before pressure gauge is installed. Wipe off split fluid thoroughly after the measurement.
- Keep engine idling during the measurement.

Regular pressure:
981 kPa (10 kg/cm², 142 psi) or less

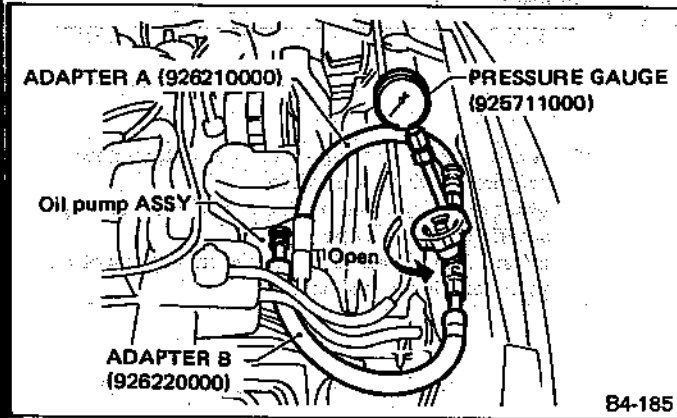


Fig. 131

Relief pressure:
7,355 — 7,846 kPa (75 — 80 kg/cm², 1,067 — 1,138 psi)

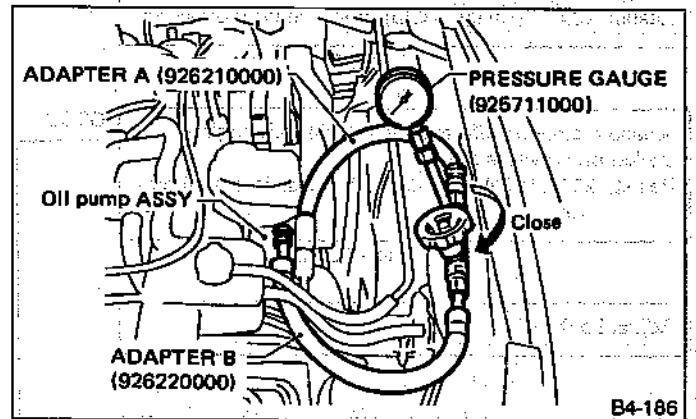
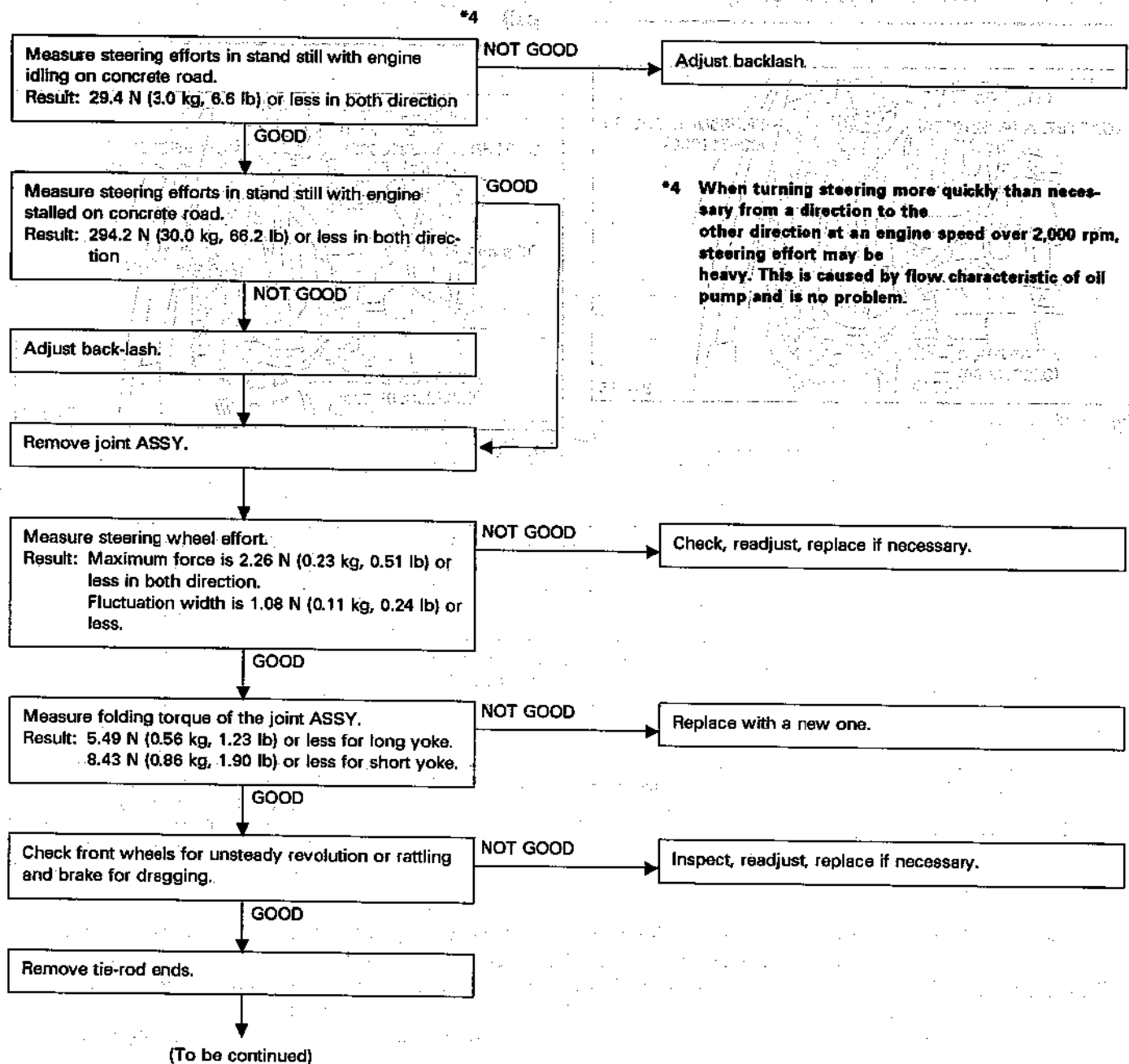
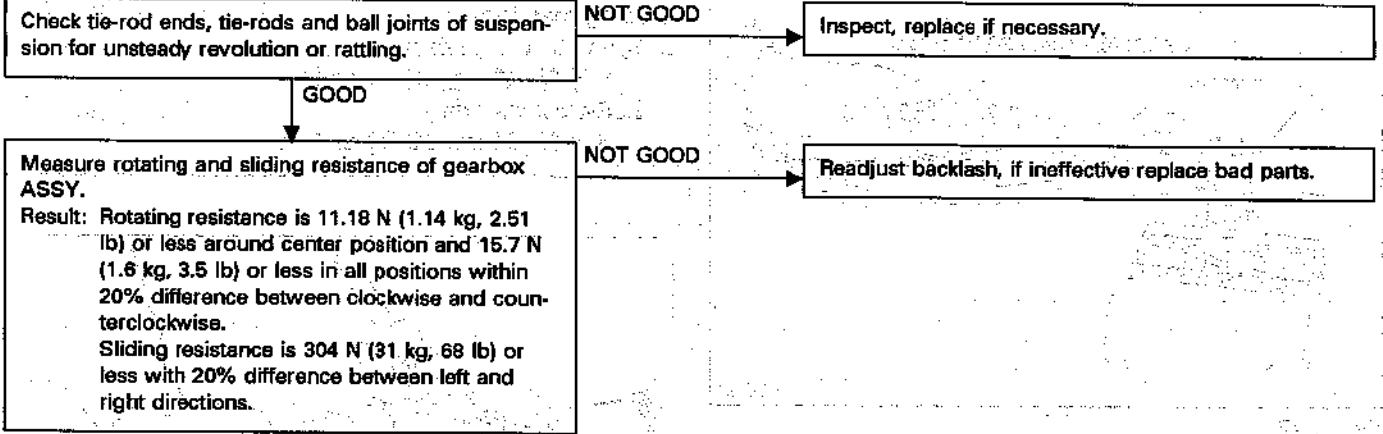


Fig. 132

3. MEASUREMENT OF STEERING EFFORT





Measurement of steering effort

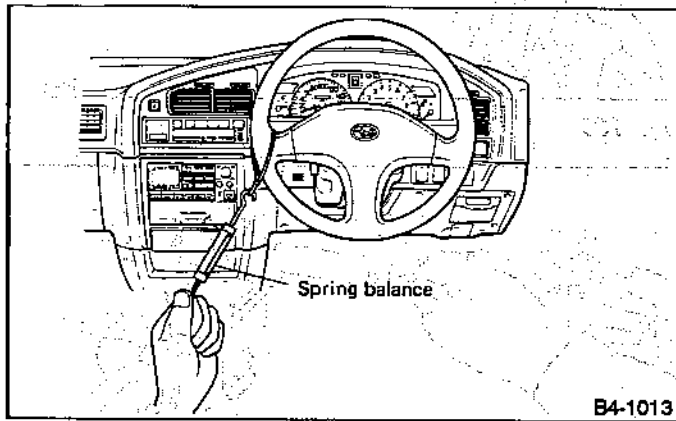


Fig. 133

Measurement of folding torque of joint assembly

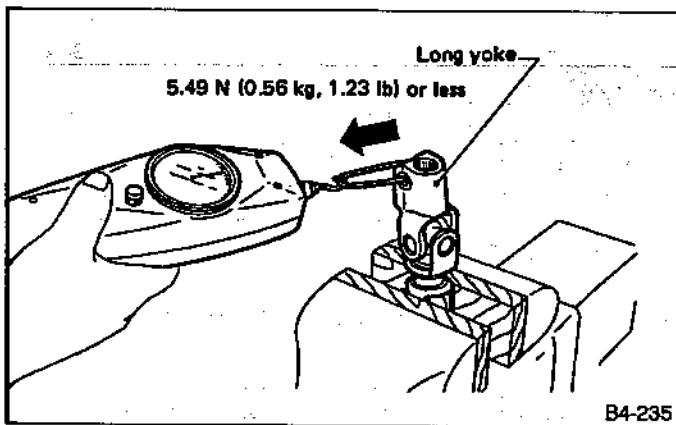


Fig. 134

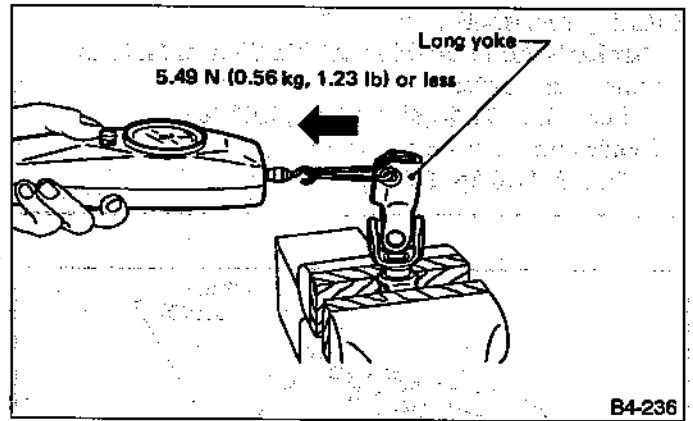


Fig. 135

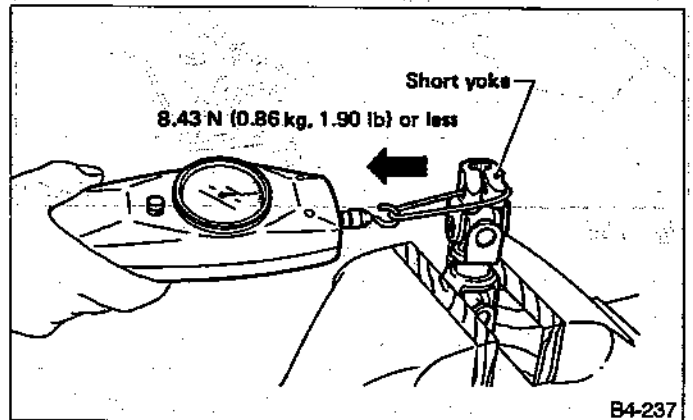


Fig. 136

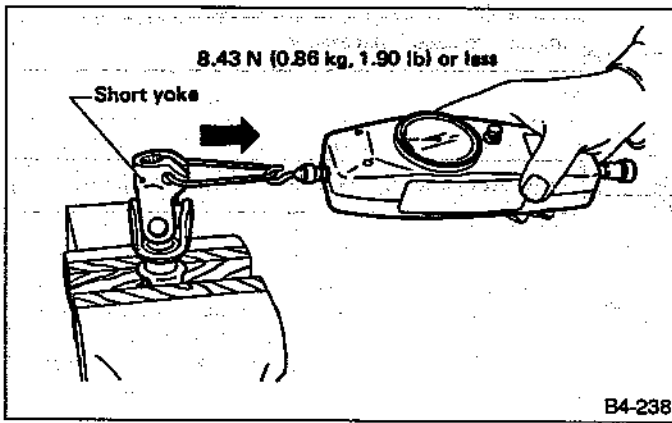


Fig. 137

Measurement of resistances of gearbox assembly

Rotating resistance:

Straight-ahead position within 30 mm (1.18 in) from rack center

Less than 11.18 N (1.14 kg, 2.51 lb)

Maximum allowable torque

15.7 N (1.6 kg, 3.5 lb)

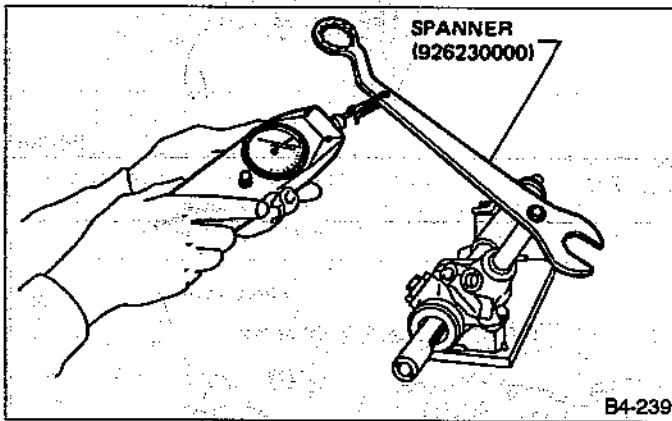


Fig. 138

Sliding resistance:

Right-turn steering

304 N (31 kg, 68 lb) or less

Left-turn steering

304 N (31 kg, 68 lb) or less

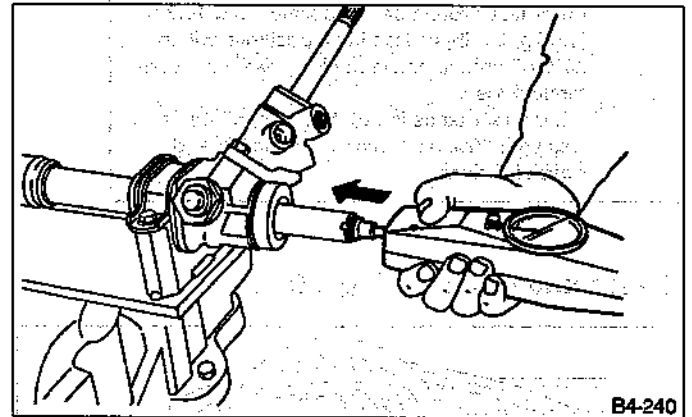


Fig. 139

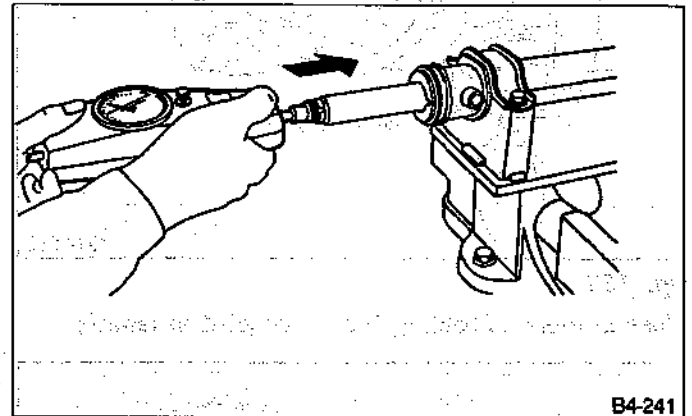
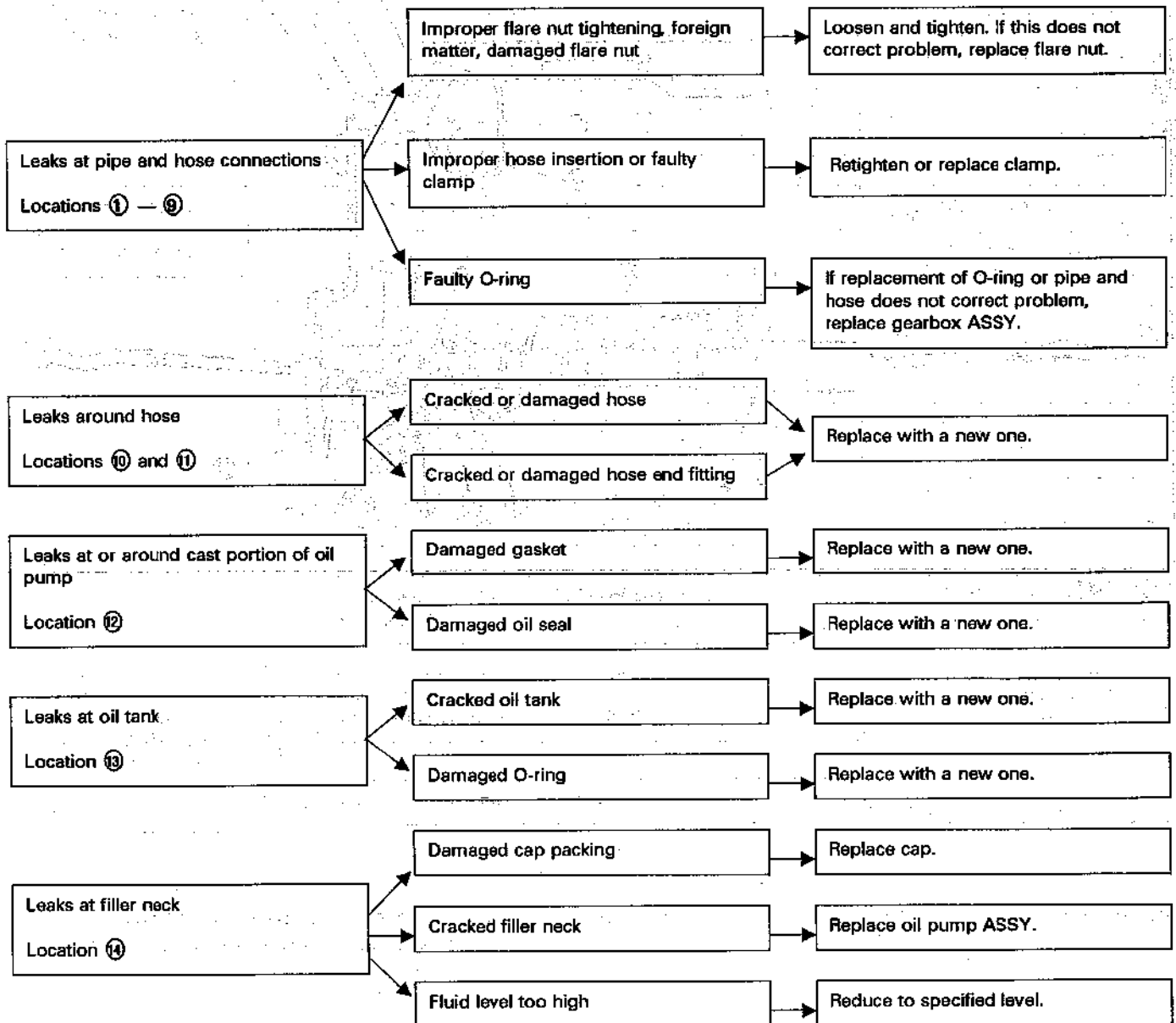


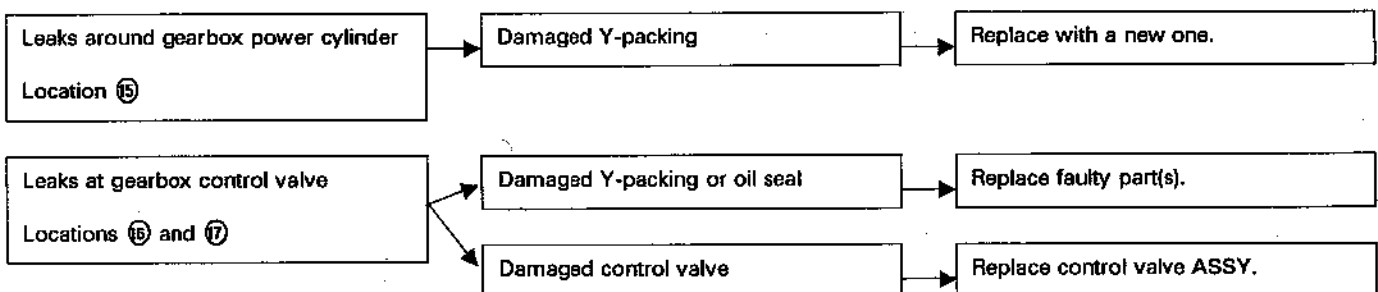
Fig. 140

4. FLUID LEAKAGE

It is likely that although one judges fluid leakage, there is actually no leakage. This is because the fluid spilt during the last maintenance was not completely wiped off. Be sure to wipe off spilt fluid thoroughly after maintenance.



Severe operation of vehicle may cause fluid to ooze out at air vent in cap. However, this is not a problem.



Wipe clean spilled fluid after servicing.

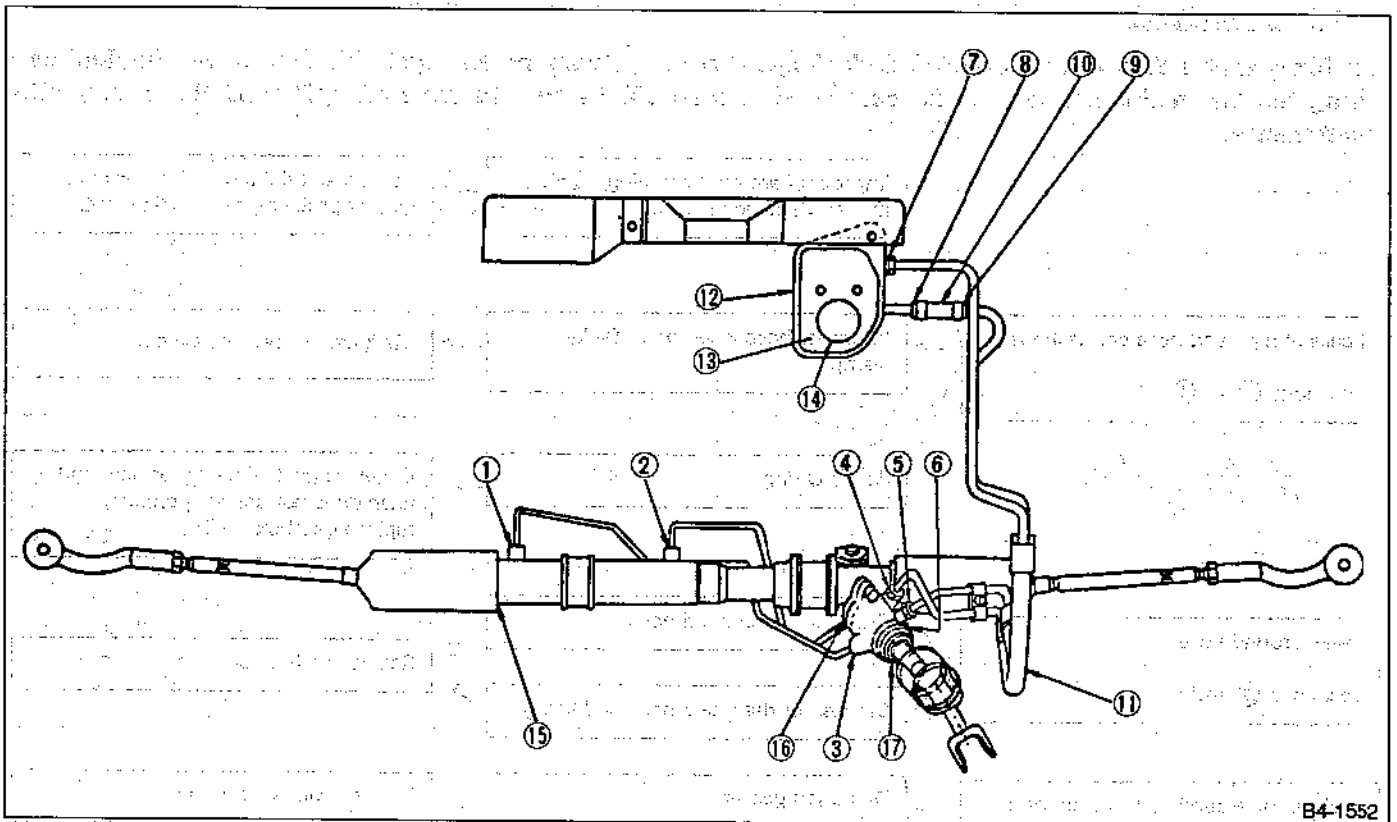
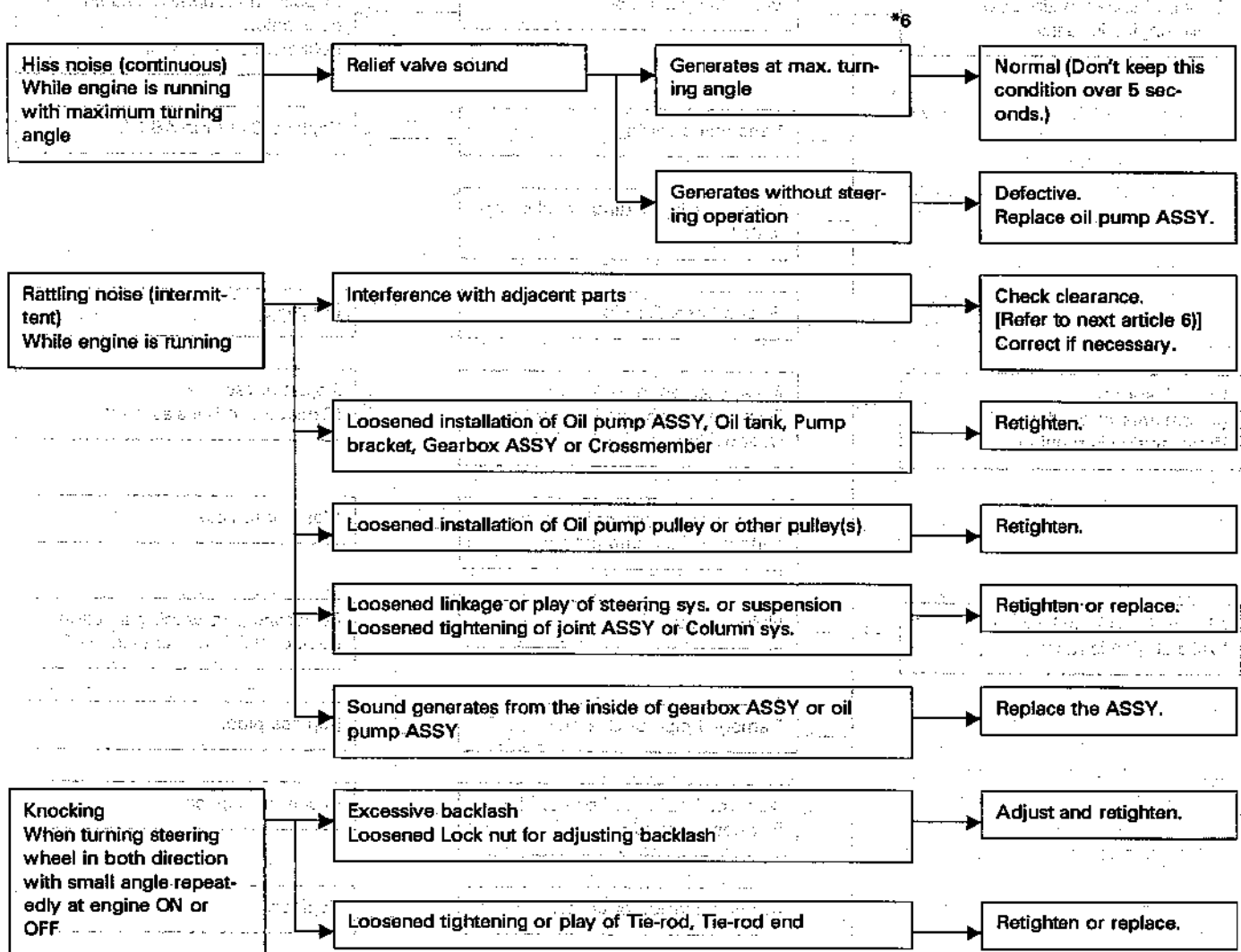


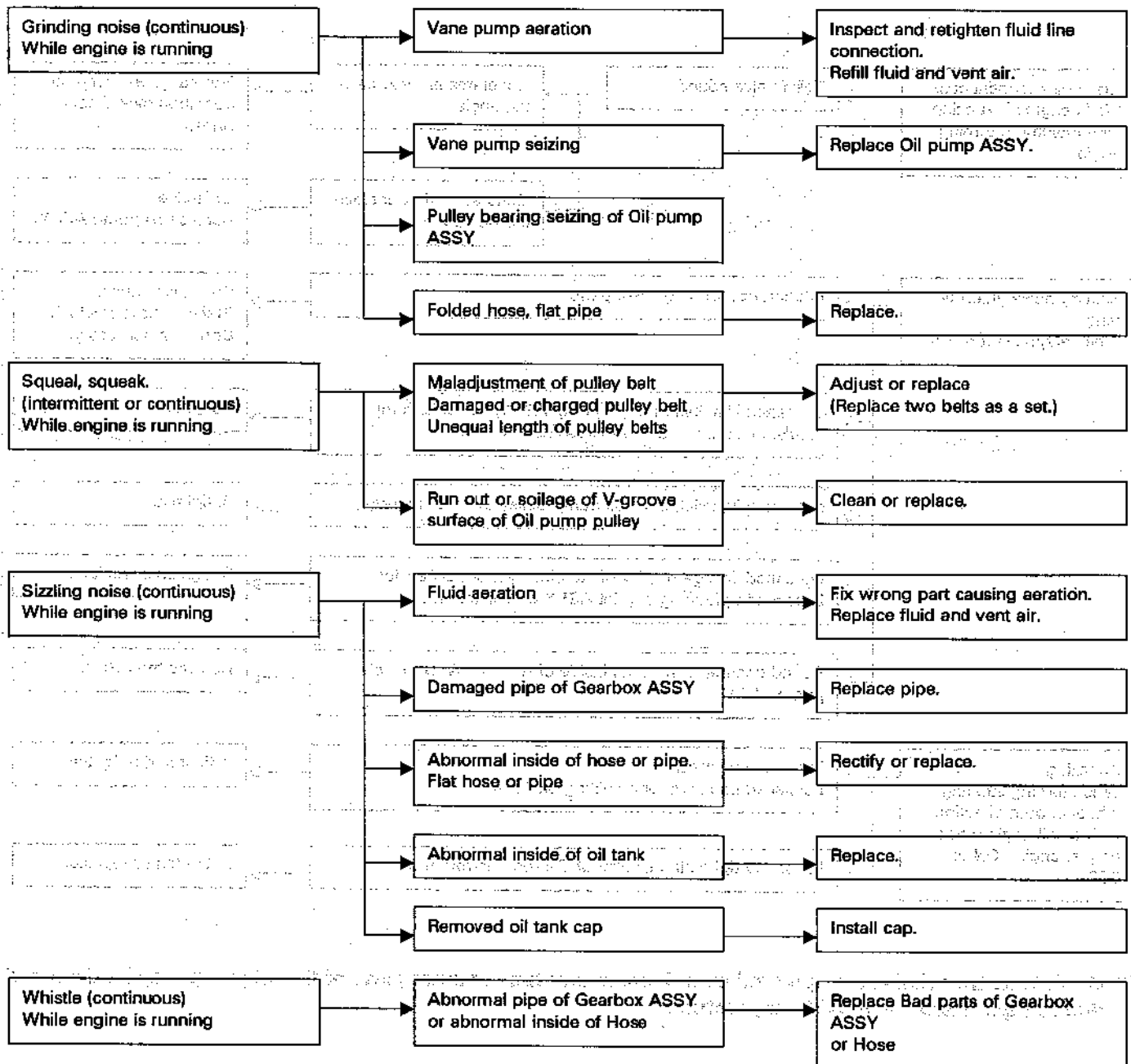
Fig. 141

5. NOISE AND VIBRATION

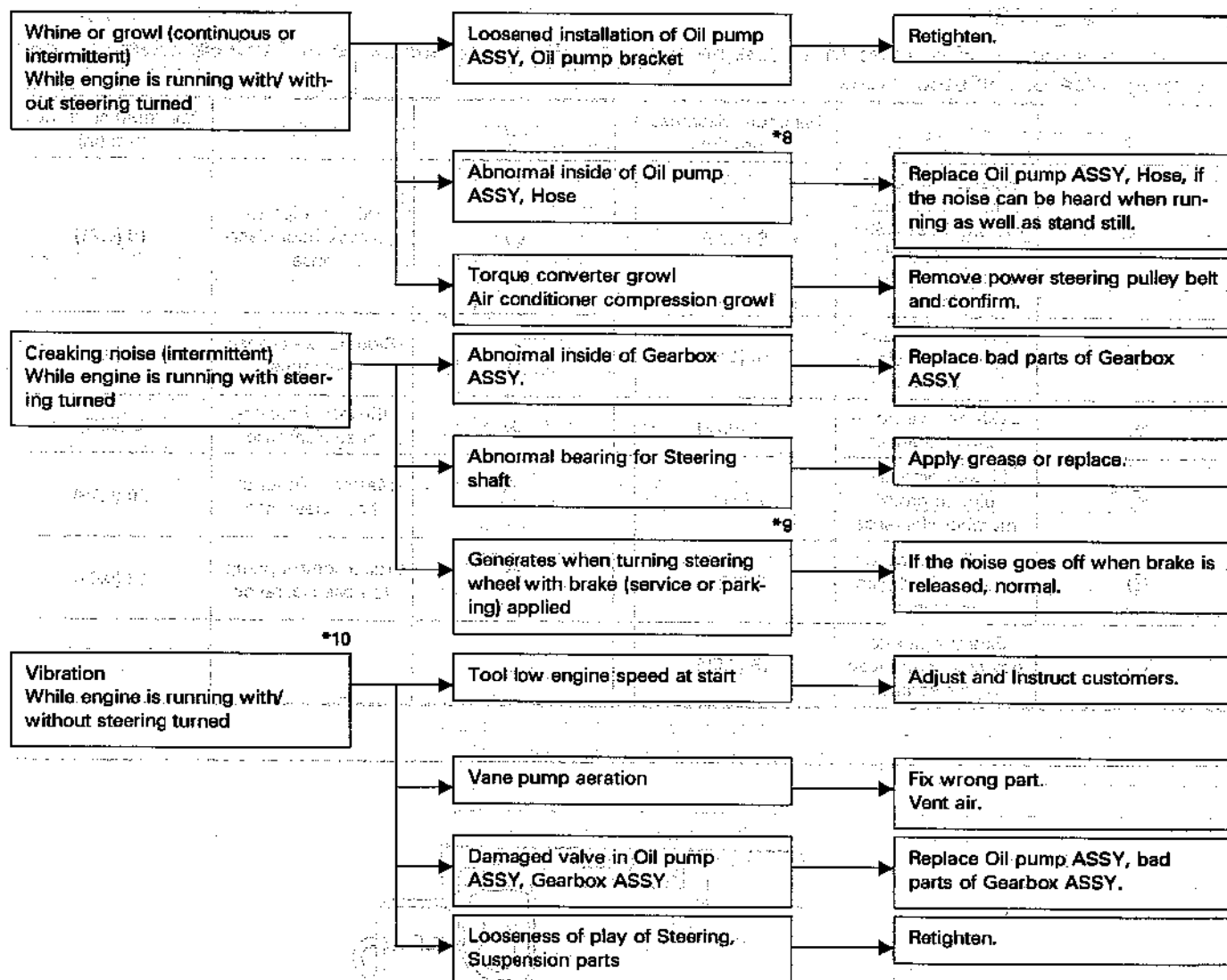


***6 Don't keep the relief valve operated over 5 sec. at any time or inner parts of the oil pump may be damaged due to rapid increase of fluid temperature.**

*7



***7 Grinding noise may be heard immediately after the engine start in extremely cold condition. In this case, if the noise goes off during warm up there is no abnormal function in the system. This is due to the fluid characteristic in extremely cold condition.**



***8** Oil pump makes whine or growl noise slightly due to its mechanism. Even if the noise can be heard when steering wheel is turned at standstill there is no abnormal function in the system provided that the noise eliminates when the car is running.

***9** When stopping with service brake and/or parking brake applied, power steering can be operated easily due to its light steering effort. If doing so, the disk rotates slightly and makes creaking noise. The noise is generated by creaking between the disk and pads. If the noise goes off when the brake is released, there is no abnormal function in the system.

***10** There may be a little vibration around the steering devices when turning steering wheel at standstill, even though the component parts are properly adjusted and have no defects.

Hydraulic systems are likely to generate this kind of vibration as well as working noise and fluid noise because of combined conditions, i.e.,

Road surface and tire surface, Engine speed and turning speed of steering wheel, Fluid temperature and braking condition.

This phenomena does not indicate there is some abnormal function in the system.

The vibration can be known when steering wheel is turned repeatedly at various speeds from slow to rapid step by step with parking brake applied on concrete road and in "D" range for automatic transmission vehicle.

6. CLEARANCE TABLE

This table lists various clearances that must be correctly adjusted to ensure normal vehicle driving without interfering noise, or any other faults.

No.	Location	Minimum clearance mm (in)	No.	Location	Minimum clearance mm (in)
①	Pipe-to-pipe clearance of crossmember and hose ASSY and pipe-to-pipe clearance of hose ASSY	5 (0.20)	⑦	Exhaust pipe-to-gearbox boot clearance	18 (0.71)
②	DOJ-to-shaft and DOJ-to-joint clearances	14 (0.55)	⑧	Side frame-to-hose clearance	15 (0.59)
③	DOJ-to-valve housing clearance	11 (0.43)	⑨	Blow-by hose-to-hose clearance	5 (0.20)
④	Pipe-to-pipe and pipe-to-crossmember clearance	2 (0.08)	⑩	Master cylinder-to-hose clearance	20 (0.79)
⑤	Stabilizer-to-power steering feed pipe clearance	5 (0.20)	⑪	Cruise control pump-to-hose clearance	12 (0.47)
⑥	Exhaust pipe-to-power steering feed pipe clearance	15 (0.59)			

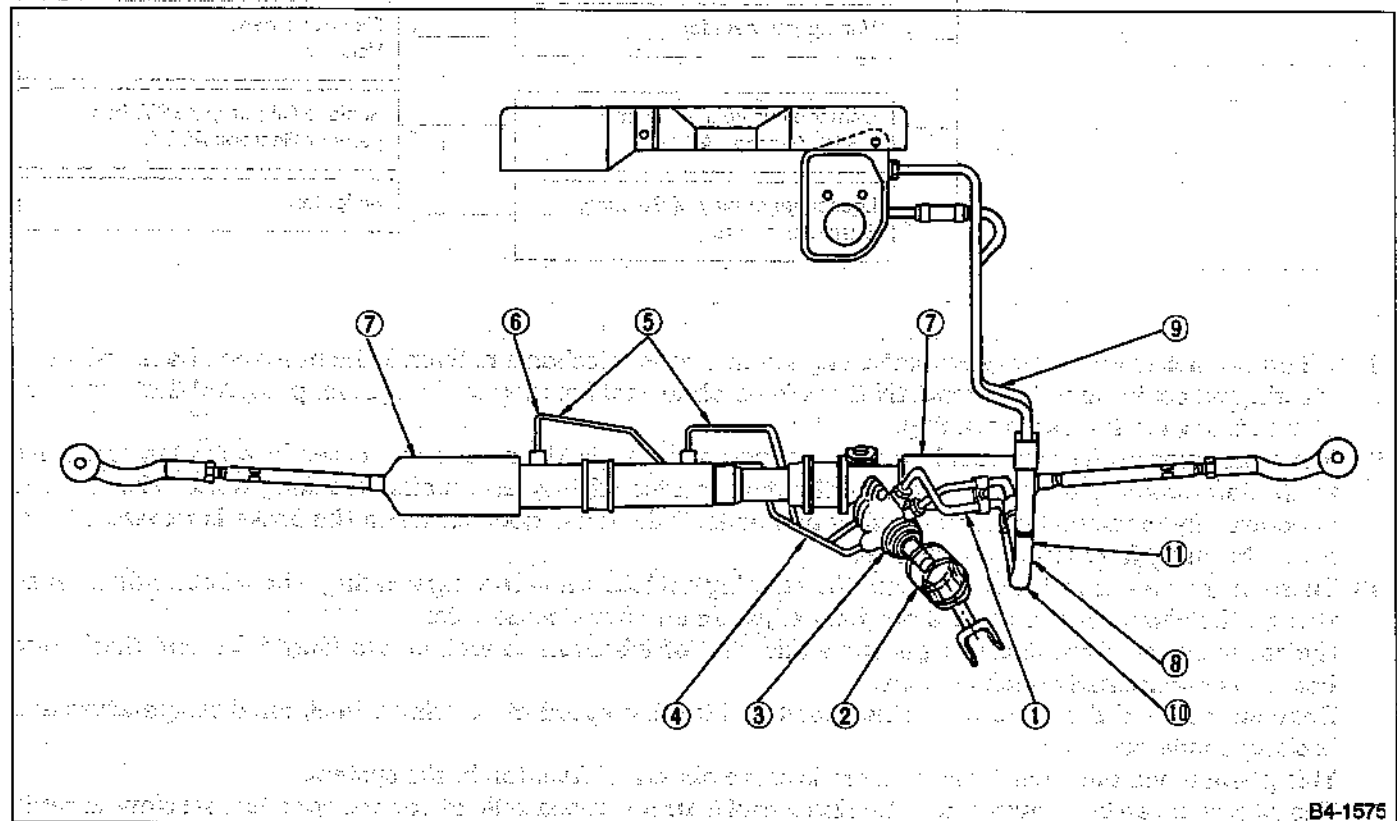
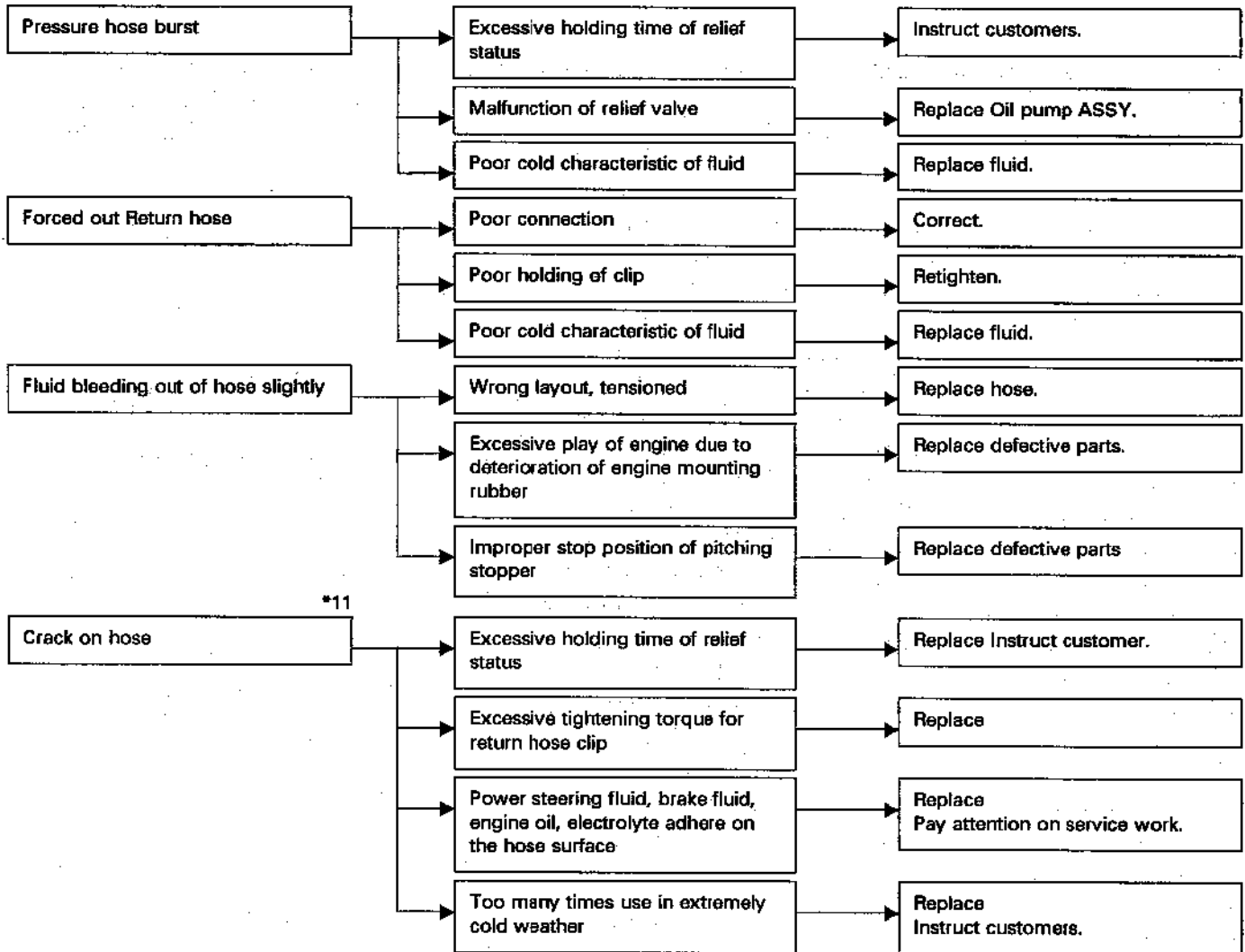


Fig. 142

B4-1575

7. BREAKAGE OF HOSES



***11** Although surface layer materials of rubber hoses have excellent weathering resistance, heat resistance and resistance for low temperature brittleness, they are likely to be damaged chemically by brake fluid, battery electrolyte, engine oil and automatic transmission fluid and their service lives are to be very shortened. It is very important to keep the hoses free from before-mentioned fluids and to wipe out immediately when the hoses are adhered with the fluids.

Since resistances for heat or low temperature brittleness are gradually declining according to time accumulation of hot or cold conditions for the hoses and their service lives are shortening accordingly, it is necessary to perform careful inspection frequently when the car is used in hot weather areas, cold weather area and/or a driving condition in which many steering operations are required in short time. Particularly continuous work of relief valve over 5 seconds causes to reduce service lives of the hoses, the oil pump ASSY, the fluid, etc. due to over heat.

So, avoid to keep this kind of condition when servicing as well as driving.

SUBARU®**1992****SERVICE
MANUAL**

	Page
M MECHANISM AND FUNCTION	2
1. Disc Brake	2
2. Rear Drum Brake	3
3. Master Cylinder	4
4. Brake Booster	5
5. Proportioning Valve	9
6. Proportioning Valve (models equipped with ABS)	11
7. Hill-Holder	12
8. Anti-lock Brake System	15
9. Parking Brake (Rear Disc Brake)	27
10. Parking Brake (Rear Drum Brake)	29
S SPECIFICATIONS AND SERVICE DATA	30
C COMPONENT PARTS	35
W SERVICE PROCEDURE	44
1. Front Disc Brake	44
2. Rear Disc Brake	52
3. Rear Drum Brake	57
4. Parking Brake (Rear Disc Brake)	62
5. Master Cylinder	65
6. Brake Booster	66
7. Brake Hose	69
8. Hill-Holder	70
9. Parking Brake Lever	71
10. Parking Brake Cable	72
11. Air Bleeding	73
12. Brake Fluid Replacement	74
13. Proportioning Valve	75
14. ABS Sensor	76
15. Hydraulic Unit for ABS System	80
16. Electronic Control Unit for ABS System	83
17. G Sensor for ABS System	84
18. Brake Hose and Pipe	85
T TROUBLESHOOTING	86
1. Entire Brake System	86
2. Hill-Holder	88
3. Troubleshooting for ABS	90
4. ABS Control Unit I/O Signal	94
5. Diagram of ABS	96
6. Troubleshooting Chart with Trouble Code	98
7. General Troubleshooting Chart	112

M MECHANISM AND FUNCTION

1. Disc Brake

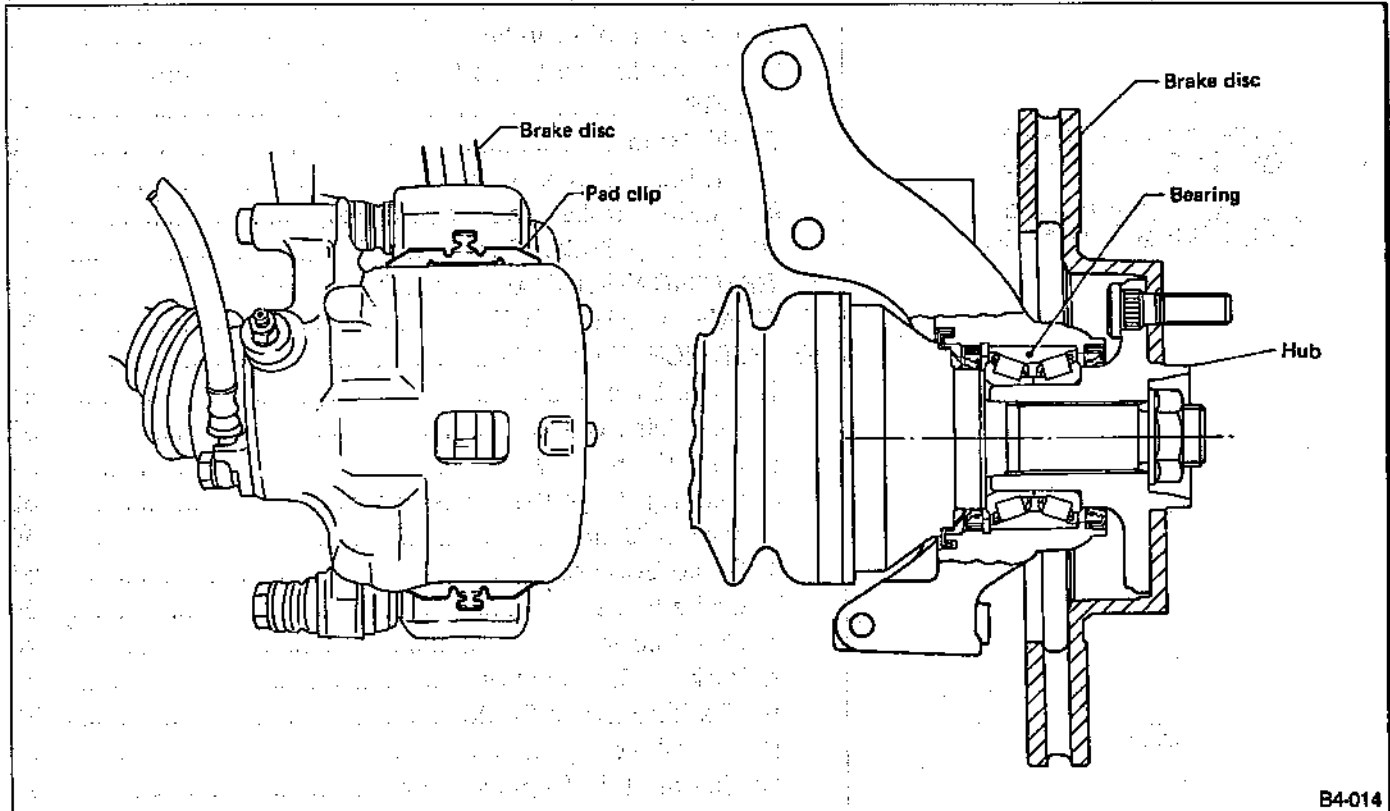
A: OUTLINE

The front brakes are ventilated disc types which feature high heat dissipation and superb braking stability. In addition, the front brake quickly restores the original

braking performance even when wet.

The brake disc, which is externally mounted, is secured together with the disc wheel using the hub bolts, to facilitate removal or installation when servicing the vehicle.

The outer brake pad is provided with an indicator which indicates pad wear limits.



B4-014

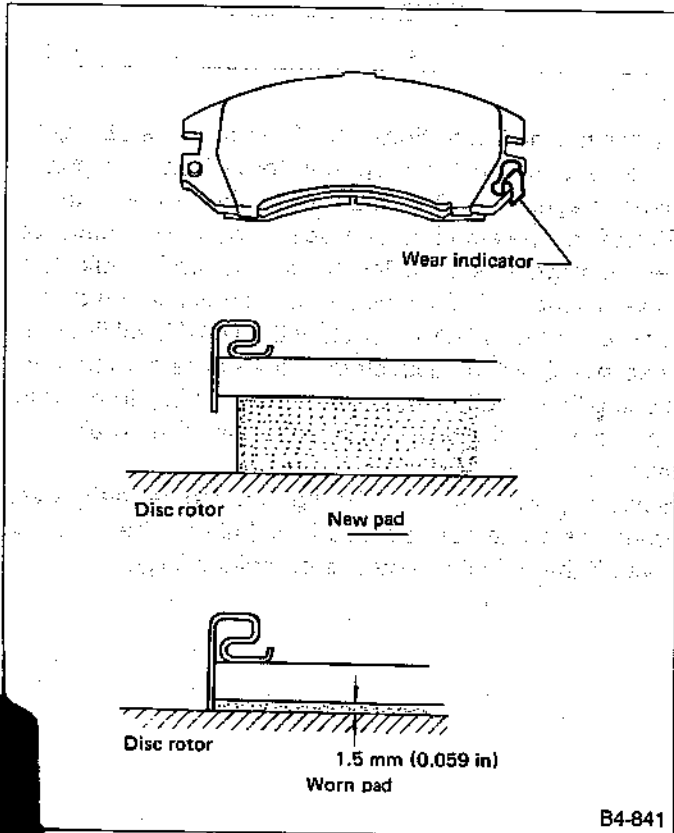
Fig. 1

B: DESCRIPTION OF BRAKE PADS

1. PAD WEAR INDICATOR

A wear indicator is provided on the outer disc brake pads. When the pad wears down to 1.5 mm (0.059 in) the tip of the wear indicator comes into contact with the disc rotor, and makes a squeaking sound as the wheel rotates.

This indicates that the pad needs to be replaced.



2

FRictional MATERIAL OF BRAKE PADS

Additional brake pad materials do not contain asbestos and are not harmful.

Rear Drum Brake

GENERAL

A rear drum brake is a leading-trailing type. When fluid pressure is applied to the wheel cylinder, the piston forces the leading and trailing shoes to expand while the lower shoe return spring joint acts as a pivot. Thus, the shoes come in contact with the inner surface of the drum producing braking action.

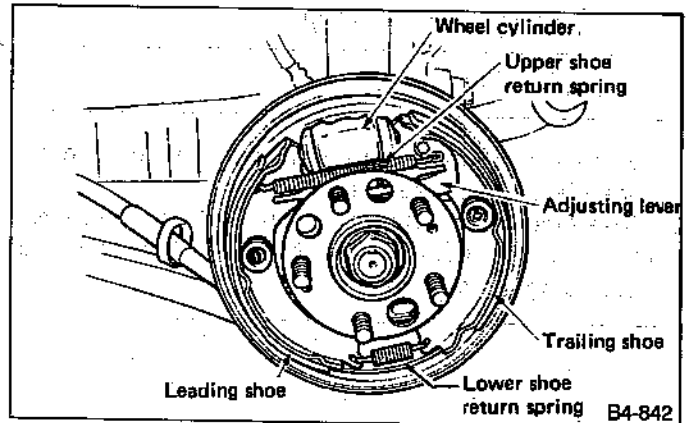


Fig. 3

When brakes are applied during the forward movement, the tip of the brake leading shoe lining is pressed against the inner surface of the drum so as to oppose the drum direction. This increases the braking force. The trailing shoe, however, undergoes a force that pushes back so that braking force applied to the trailing shoe decreases.

The above shoe operation is reversed while the vehicle is backing up, with the braking force exerted on the trailing shoe greater than that on the leading shoe. It follows that there is no difference in braking force between the directions in which the vehicle moves.

B: OPERATION

1. AUTOMATIC ADJUSTER

The brake lining-to-drum clearance is automatically compensated for by the automatic adjuster. When the brake shoe is contracting after expansion, the adjuster lever rotates the adjuster ASSY's screw to lengthen adjuster ASSY so that the clearance is maintained at the specified value.

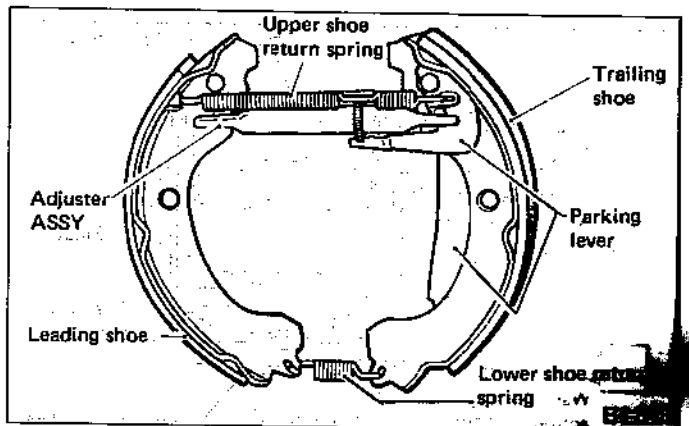


Fig. 4

3. Master Cylinder

A: FUNCTION

- 1) A sealed reservoir tank is adopted to extend the service life of the brake fluid.
- 2) The fluid level indicator is built into the reservoir tank for easy and correct monitoring of the fluid level when adding brake fluid.

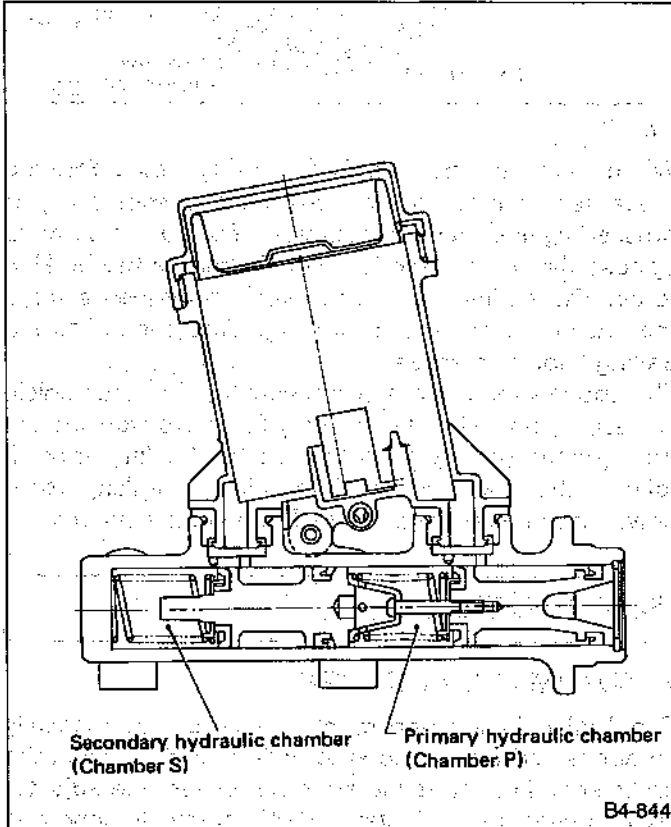


Fig. 5

1. BRAKE FLUID LEVEL INDICATOR

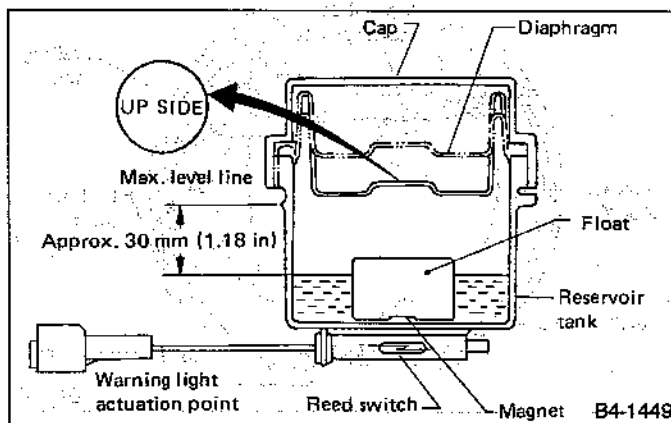


Fig. 6

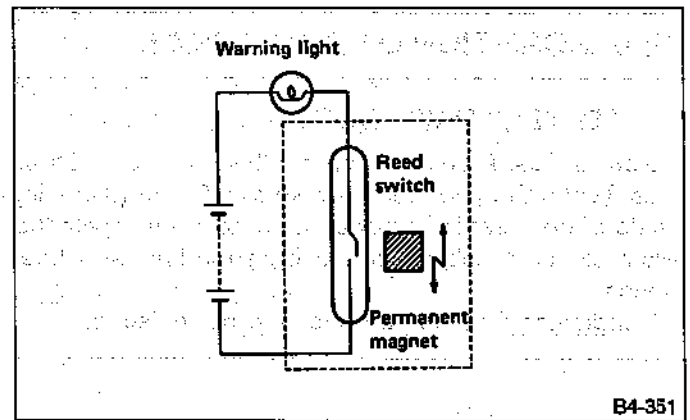


Fig. 7

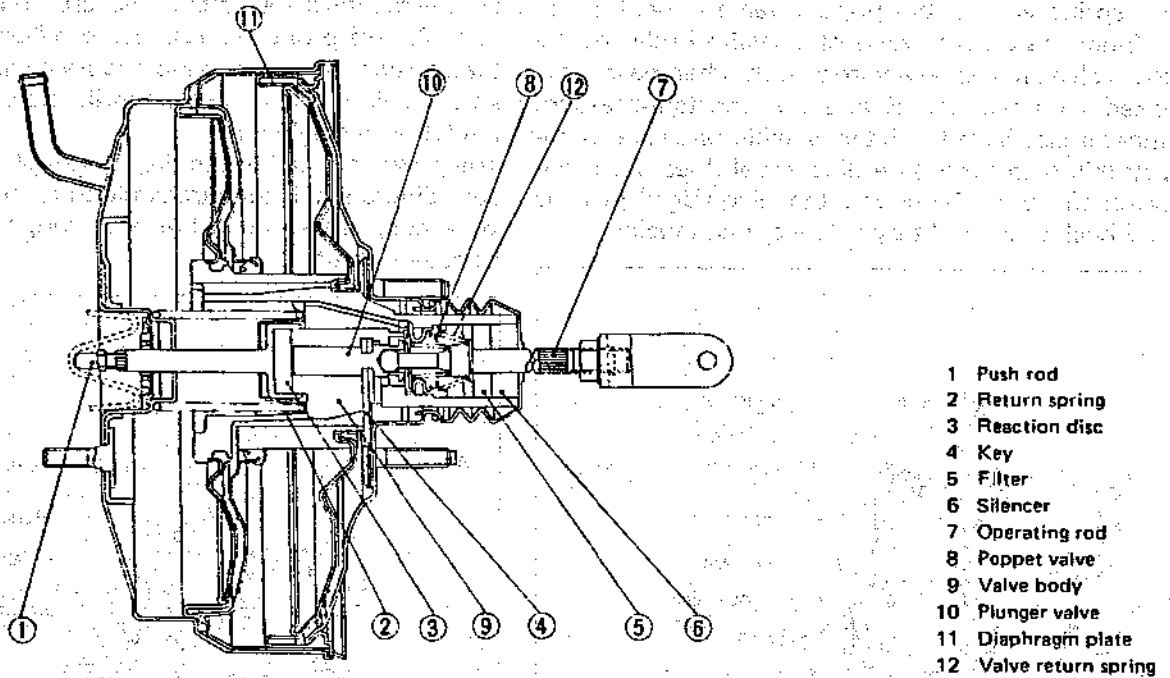
Under normal conditions, the float remains above the reed switch, and the magnetic force from the permanent magnet in the float is unable to activate it. Therefore, the circuit is kept open, and the warning light remains off. The float lowers as the brake fluid level lowers, and if it falls below the specified fluid level [approx. 30 mm (1.18 in) below the MAX level line], the reed switch will be activated by the permanent magnet, closing the circuit. In this event, the warning light comes on and warns the driver of a reduction of the brake fluid level.

However, the lamp may be lighted momentarily even when the brake fluid surface is still above the specified level, if the vehicle body tilts or swings largely.

4. Brake Booster

A: GENERAL

The brake booster is a tandem type that utilizes two small diameter diaphragms to provide high brake boosting effects.



B4-1328

Fig. 8

B: OPERATION**1. BRAKE BOOSTER "OFF"**

The plunger valve comes in contact with the poppet valve so that atmospheric air passing through the filter and silencer is shut out by the atmospheric valve (of the poppet valve).

The plunger valve is moved to the key at the right by the return spring so that the poppet valve is held at the right. Since the vacuum valve of the valve body and the poppet valve are kept away from each other, passage A is linked with passage B and the constant-pressure chamber is also linked with the variable-pressure chamber. At this point, pressure differential does not occur between the two chambers; the diaphragm plate is moved back to the right by return spring tension.

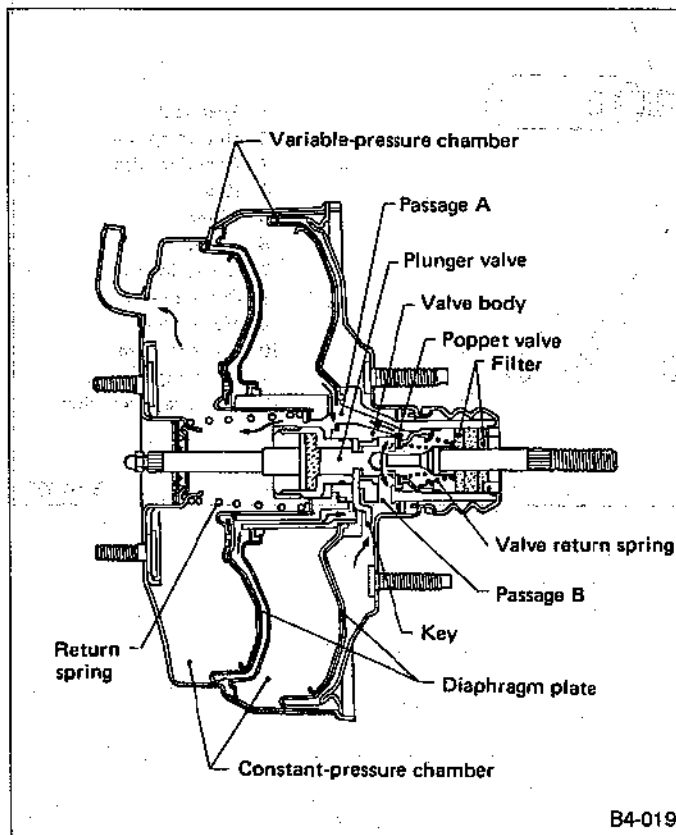


Fig. 9

B4-019

2. BRAKE BOOSTER "ON"

When the brake pedal is depressed, the operating rod pushes the plunger valve so that the poppet valve comes in contact with the vacuum valve of the valve body. This shuts off the circuit between passages A and B, as well as the circuit between the constant- and variable-pressure chambers.

Further movement of the plunger valve moves the atmospheric valve away from it so that atmospheric air is directed to the variable-pressure chamber via passage B. This produces a pressure differential between the constant- and variable-pressure chambers.

As a result, the diaphragm and its plate are moved to the left as a single unit.

The power applied to the diaphragm plate by the pressure differential is then transmitted to the reaction disc via a hub, as well as to the push rod, and produces a booster output.

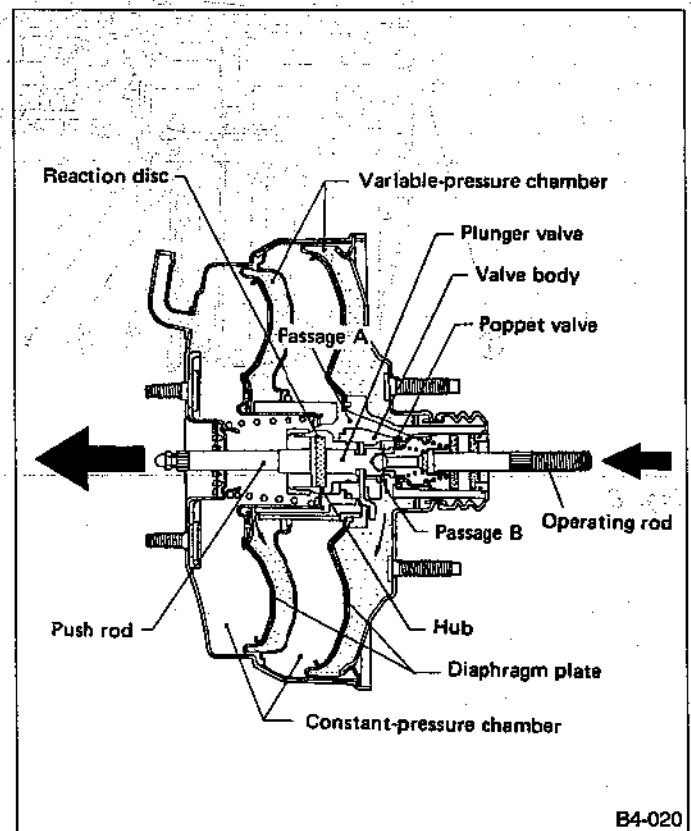


Fig. 10

B4-020

3. BRAKE BOOSTER UNDER MEDIUM LOAD

The poppet valve comes in contact with the plunger valve and valve body when a force pushes the center of the reaction disc (at the contact portion of the plunger valve) via the operating rod and plunger valve. This occurs when brake pedal depression is balanced with a force pushing the plunger valve (via the push rod and reaction disc) due to the reaction force of oil pressure delivered from the master cylinder.

As a result, pressure differential is maintained between the constant-pressure chamber and variable-pressure chamber unless the pedal depression force is changed.

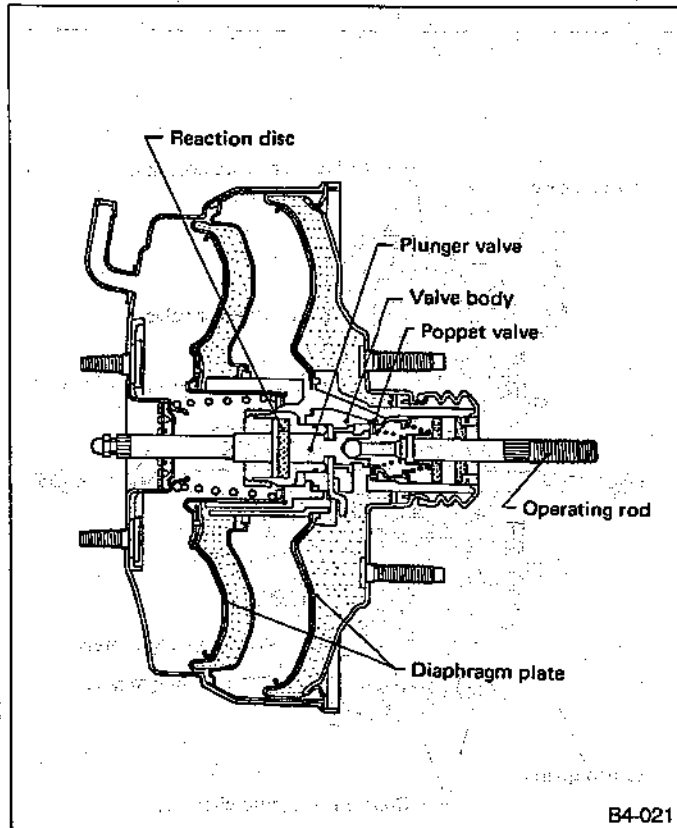


Fig. 11

4. BRAKE BOOSTER UNDER FULL-LOAD CONDITIONS

When pedal depression increases to such an extent that the variable-pressure chamber is maintained at atmospheric pressure, the maximum pressure differential acts on the diaphragm plate.

Further pedal depression does not act on the diaphragm plate but rather on the push rod.

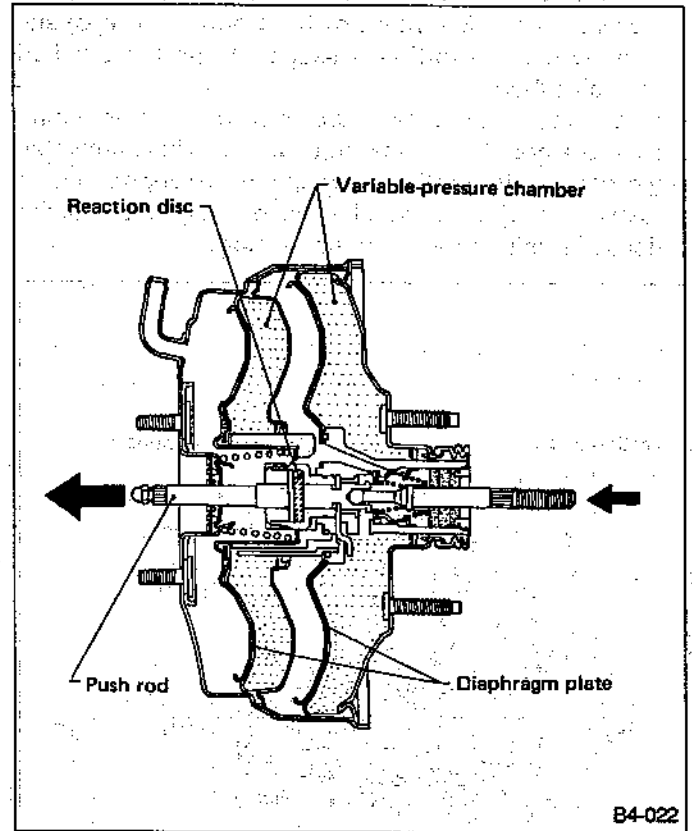


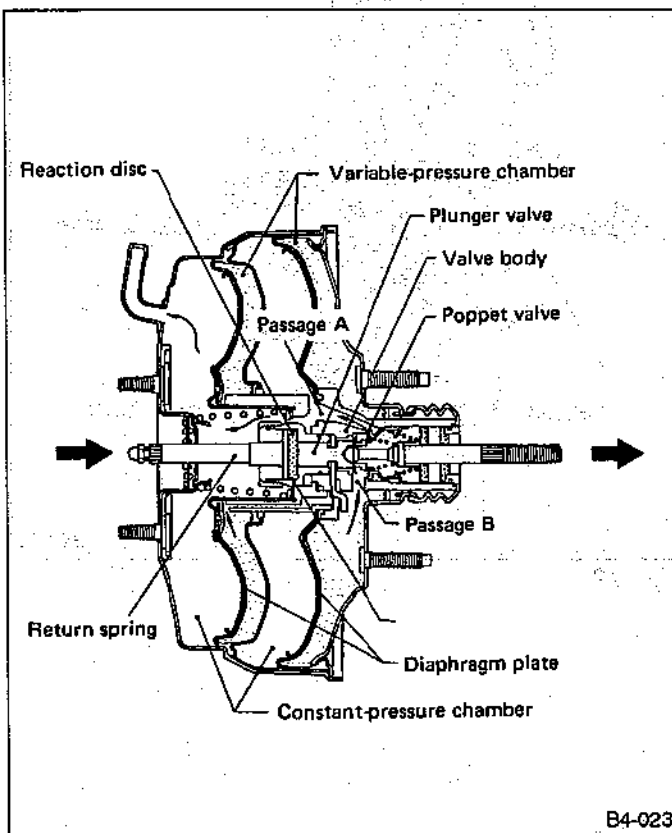
Fig. 12

5. BRAKE BOOSTER RELEASED

When the force of brake pedal depression decreases, the forces acting on the reaction disc and plunger valve are unbalanced, so that the plunger valve is moved to the right.

The plunger valve then comes in contact with the atmospheric valve of the poppet valve to shut off the passage between the variable-pressure chamber and atmospheric air and, at the same time, moves the poppet valve back. Movement of the poppet valve opens the vacuum valve so that passages A and B are linked with each other.

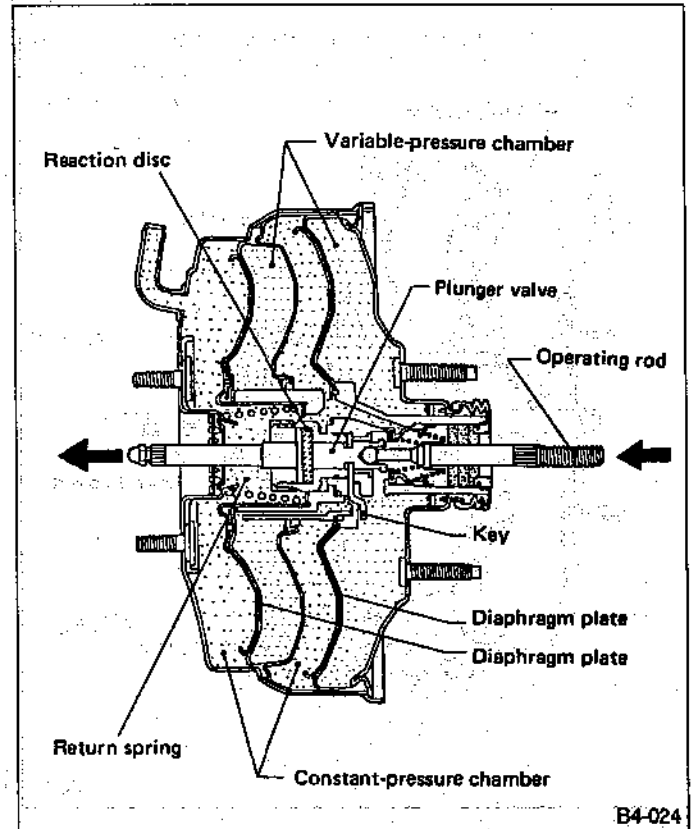
Air from the variable-pressure chamber is then delivered to the constant-pressure chamber. This eliminates any pressure differential between the two chambers. As a result, the diaphragm plate is pushed back to the "release" position by the return spring.



6. BRAKE BOOSTER WITH NO VACUUM

When the brake pedal is depressed while the constant- and variable-pressure chambers are held at atmospheric pressure, the operating rod moves to the left. This moves the plunger valve which in turn pushes the hub via the key.

The reaction disc (which is built into the hub) then moves the master cylinder piston via the push rod. At this point a boosting force does not occur, but oil pressure is produced by movement of the master cylinder piston. As a result, the system serves as a hydraulic brake.



5. Proportioning Valve

A: GENERAL

The proportioning valve for dual piping systems is adopted for controlling the braking force.

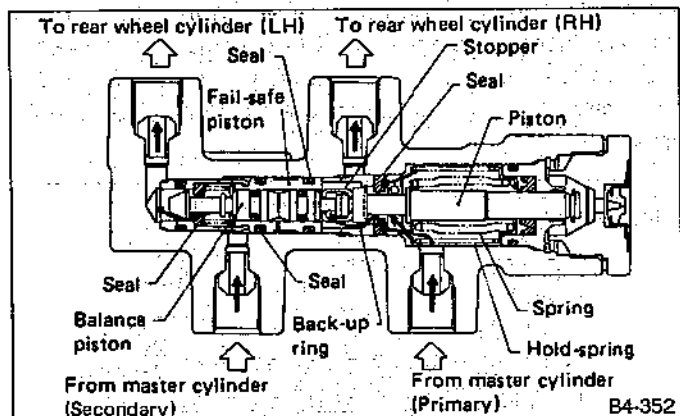


Fig. 15 Construction

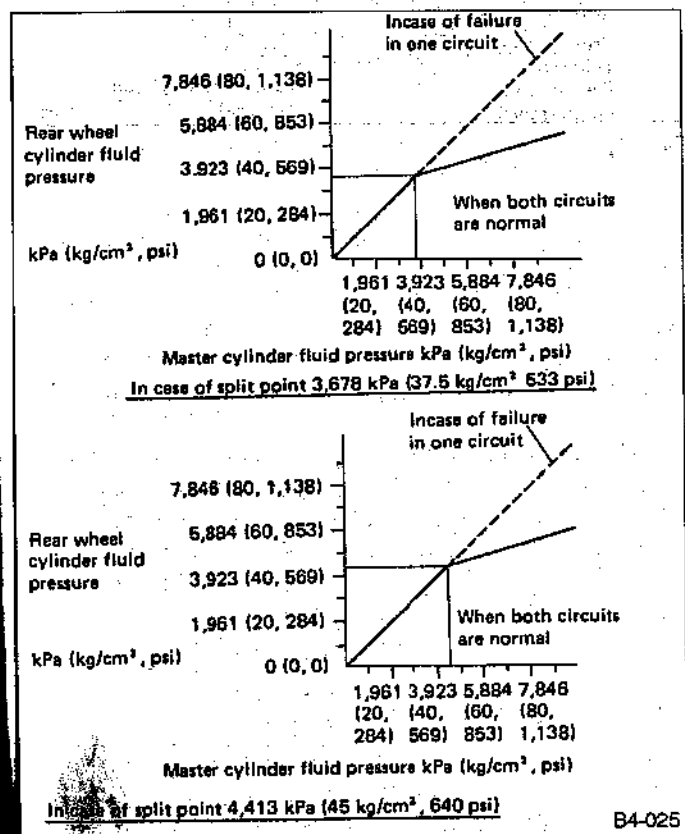


Fig. 16

B: OPERATION

1. OPERATION DURING NORMAL CONDITIONS

When the fluid pressure in the master cylinder is low (the fluid pressure before the split point), the piston is pressed by the spring load and the valve remains inoperative. As a result, the fluid pressure in the master cylinder is held equal to the fluid pressure in the rear wheel cylinder.

1) When the master cylinder fluid pressure rises, the piston in the primary circuit is moved rightward against the spring load, and brought into contact with the seal (1) (as shown in the figure). The master cylinder fluid pressure chamber (chamber A) is therefore cut off from the rear wheel cylinder fluid pressure chamber (chamber B), and the fluid pressure to the rear wheel cylinder is thus controlled. (The pressure at this moment is the split point pressure.)

If the fluid pressure in chamber A rises further, the piston is moved leftward, off the seal (1), and this causes the fluid pressure in chamber B to rise. The piston is then moved rightward, and brought into contact with the seal (1) again. After this, the piston repeats this contact with the seal (1) in this way, thereby controlling the fluid pressure in the rear wheel cylinder.

2) When the fluid pressure in chamber B is controlled in the secondary circuit, the balance piston is moved rightward by the fluid pressure difference between chamber B and chamber C, and brought into contact with the seal (2), and the fluid pressure in chamber D is controlled. Since sectional areas A1 and A2 are equal, the balance piston is pushed by equal forces from the right and left. If the fluid pressure rises in chamber B, the balance piston performs control to equalize the fluid pressure in chamber D and chamber B by repeating open-close operation with the seal (2).

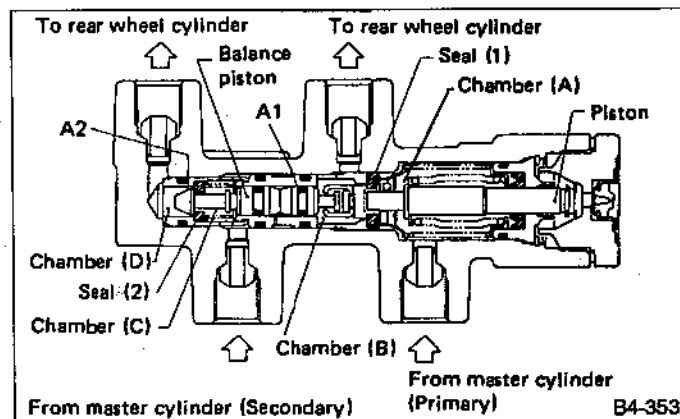


Fig. 17

2. OPERATION IN CASE OF CIRCUIT FAILURE

1) Failure of primary circuit

If the primary circuit fails, the fail-safe piston and balance piston are moved rightward by the fluid pressure in the master cylinder in the secondary circuit until the piston contacts the plug. In this case, the balance piston remains off the seal (2), and no split point is created in the graph. That is, the fluid pressure in the secondary side rear wheel cylinder is equal to the fluid pressure in the master cylinder.

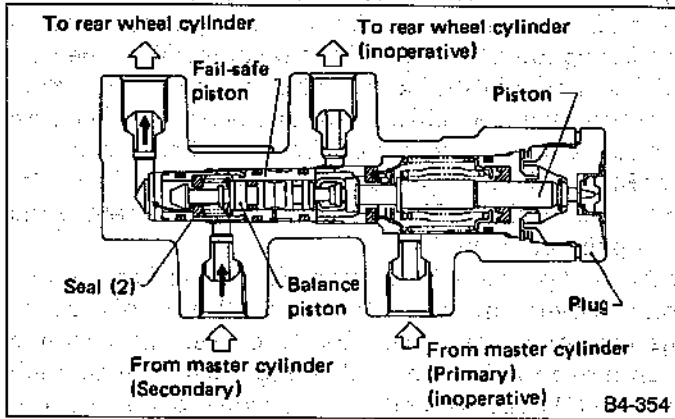


Fig. 18

2) Failure of secondary circuit

If the secondary circuit fails, the balance piston is moved leftward by the fluid pressure in chamber B until the end of the piston contacts the stopper. Since sectional area A1 is greater than A2, the piston remains unmoved even after the master cylinder fluid pressure has reached the split point, and the piston is kept off the seal (1). Hence, no split point is created in the graph, and the rear wheel cylinder fluid pressure of the primary circuit is kept equal to the master cylinder fluid pressure.

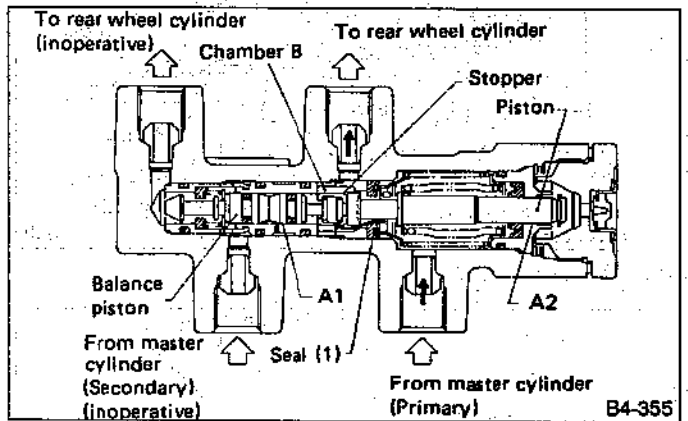


Fig. 19

6. Proportioning Valve (models equipped with ABS)

A: OPERATION

1. OPERATION DURING NORMAL CONDITIONS

1) Operation before the split point

Piston ① is held by spring ④ so that valve ③ is kept away from valve seat ②.

Under this condition, fluid pressure "P₃" to rear wheel cylinders equals fluid pressure "P₂" from master cylinder.

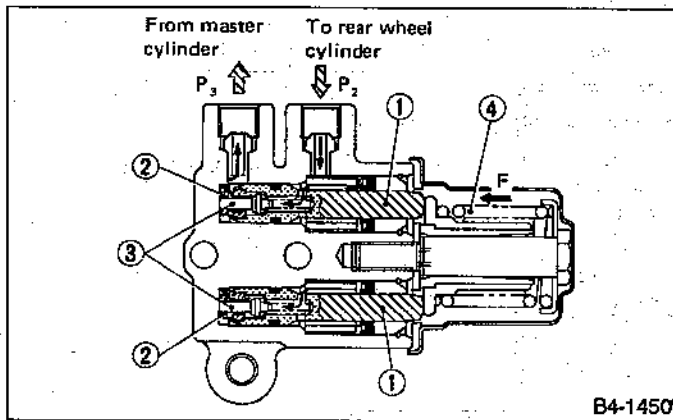


Fig. 20

2) Operation near the split point

Force "f₁", applied to piston ① by spring ④, is one-half of spring force "F". In other words, "f₁" = 1/2 "F".

Force "f₂" is also applied to piston ① in the direction opposite to spring force "F" due to fluid pressure "P₂" generated by master cylinder according to cross sectional area "A".

Spring force "f₂" increases responsively with fluid pressure "P₂". When "f₂" is greater than "f₁", piston ① moves in direction opposite to spring force "F". This causes valve ② to come in contact with valve seat ③, blocking fluid passage.

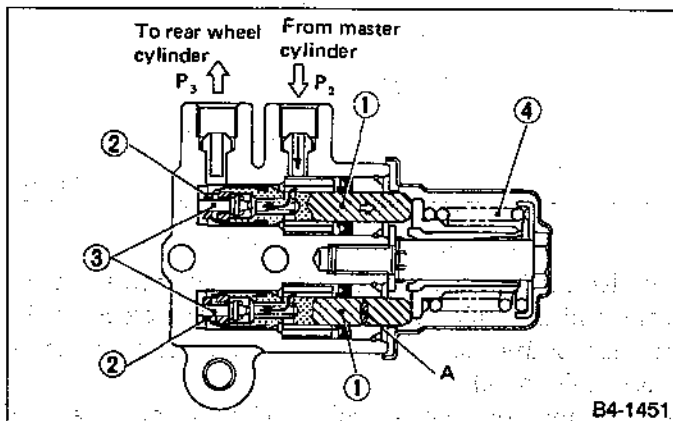


Fig. 21

3) Immediately before fluid passage is closed, fluid pressure "P₂" is held equal to pressure "P₃". When brake pedal is depressed to increase fluid pressure "P₂", piston ① moves in the same direction as spring force "F", opening fluid passage.

However, since fluid passage is closed again immediately after pressure "P₂" equals "P₃", pressure "P₃" is held at a value of less than pressure "P₂".

2. OPERATION IN CASE OF CIRCUIT FAILURE

If either primary or secondary circuit fails to operate, spring force "F" is supported by one of pistons ①. At this point, fluid pressure "P₂", which initially reaches the split point, is greater than that produced under normal conditions.

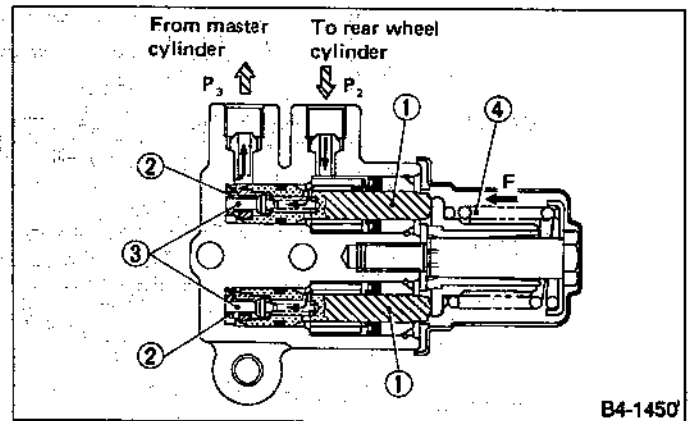


Fig. 22

8. Anti-lock Brake System

A: OUTLINE

1. FEATURE

The ABS (Anti-lock brake system) electrically controls brake fluid pressure to prevent wheel "lock" during braking on slippery road surfaces, thereby improving directional/steering stability as well as shortening the braking distance.

If the ABS becomes inoperative, the fail-safe system activates to ensure it acts as a conventional brake system. The warning light also comes on to indicate that the ABS is malfunctioning.

The front-and-rear wheels utilize a 4-sensor, 4-channel control design: the front wheels have an independent control design*1 and the rear wheels have a select low control design*2.

*1: A system which independently controls fluid pressure to left and right front wheels.

*2: A system which provides the same fluid pressure control for the two rear wheels if either wheel starts to "lock."

2. COMPONENTS

The ABS consists of four tone wheels ⑤, four ABS sensors ④, an electronic control unit ⑧, a hydraulic control unit ⑦, a G sensor ⑥ and a warning light ⑩.

ABS component parts

Item	Function
Tone wheel	Attached to each wheel hub and rotates at the same speed as the hub.
ABS sensor	Emits a wheel speed signal during tone wheel rotation.
Electronic control unit	Receives wheel-speed signals from speed sensors and sends a control signal to hydraulic unit so that fluid pressure is optimally controlled.
Hydraulic control unit (There are two types of ABS, NIPPON ABS and BOSCH ABS.)	Receives a control signal from electronic control unit and controls respective wheel cylinder fluid pressure.
G sensor (4WD manual transmission model)	Detects vehicle deceleration.
Warning light	Comes on when ABS becomes inoperative.

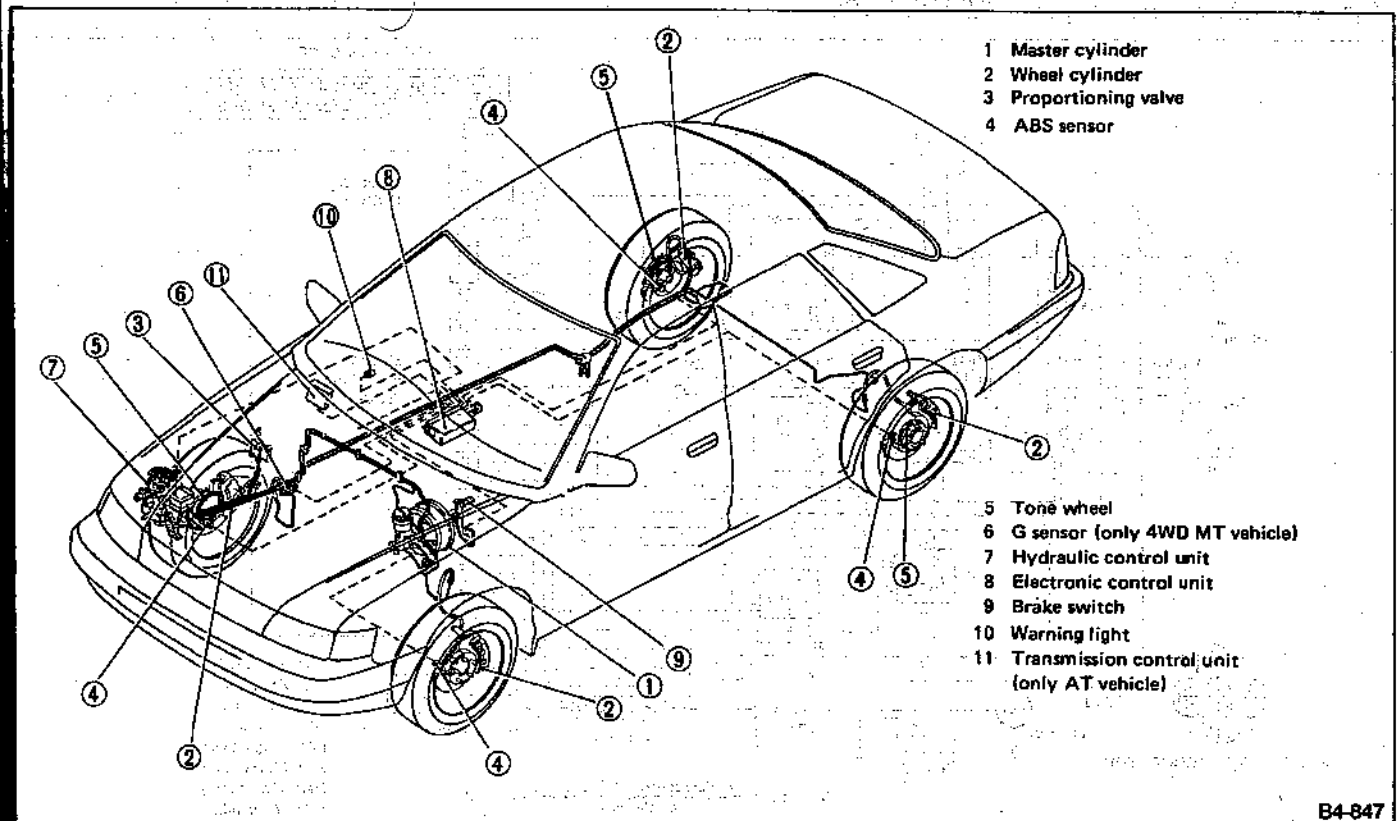


Fig. 30

B4-847

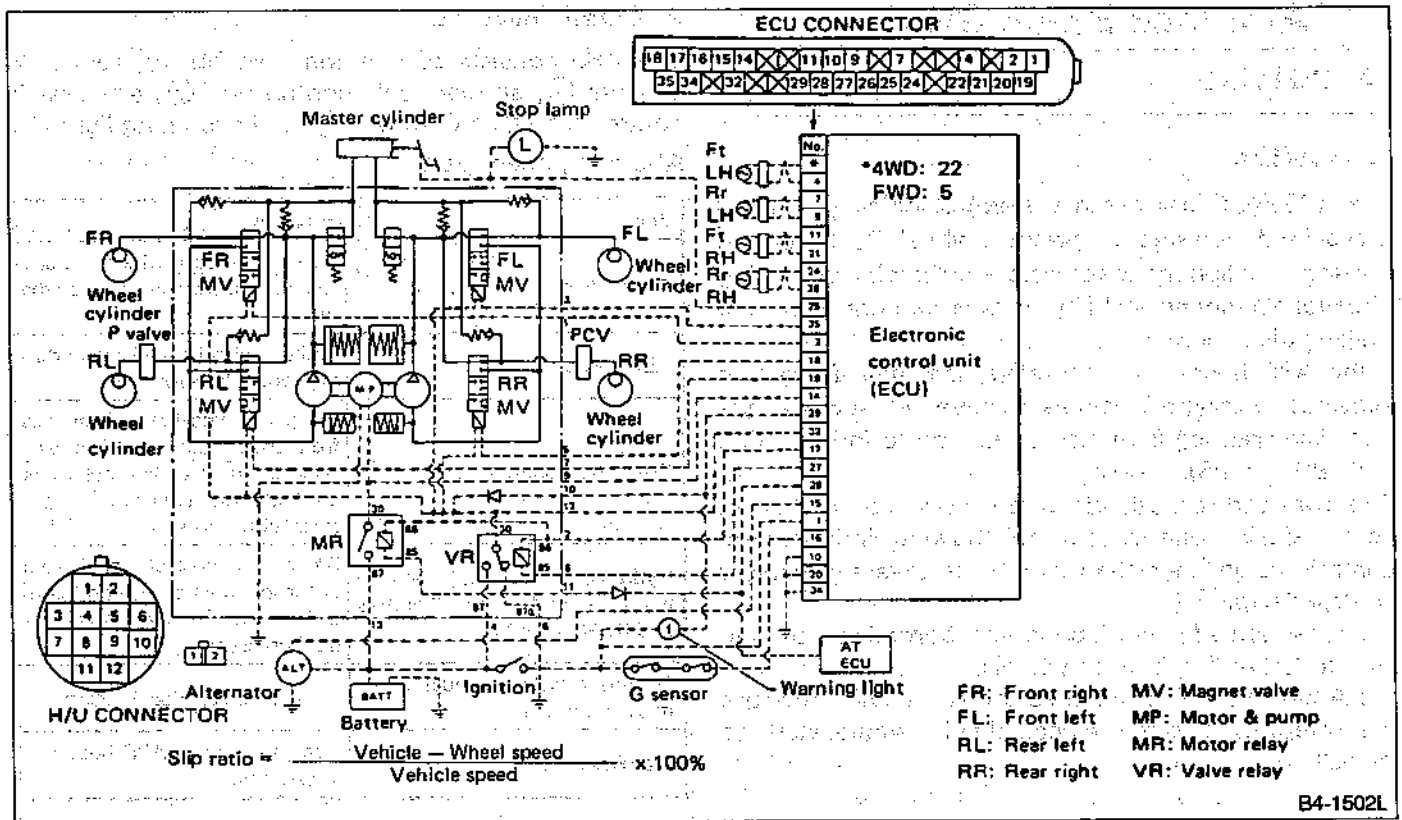


Fig. 31 ABS system diagram (NIPPON ABS)

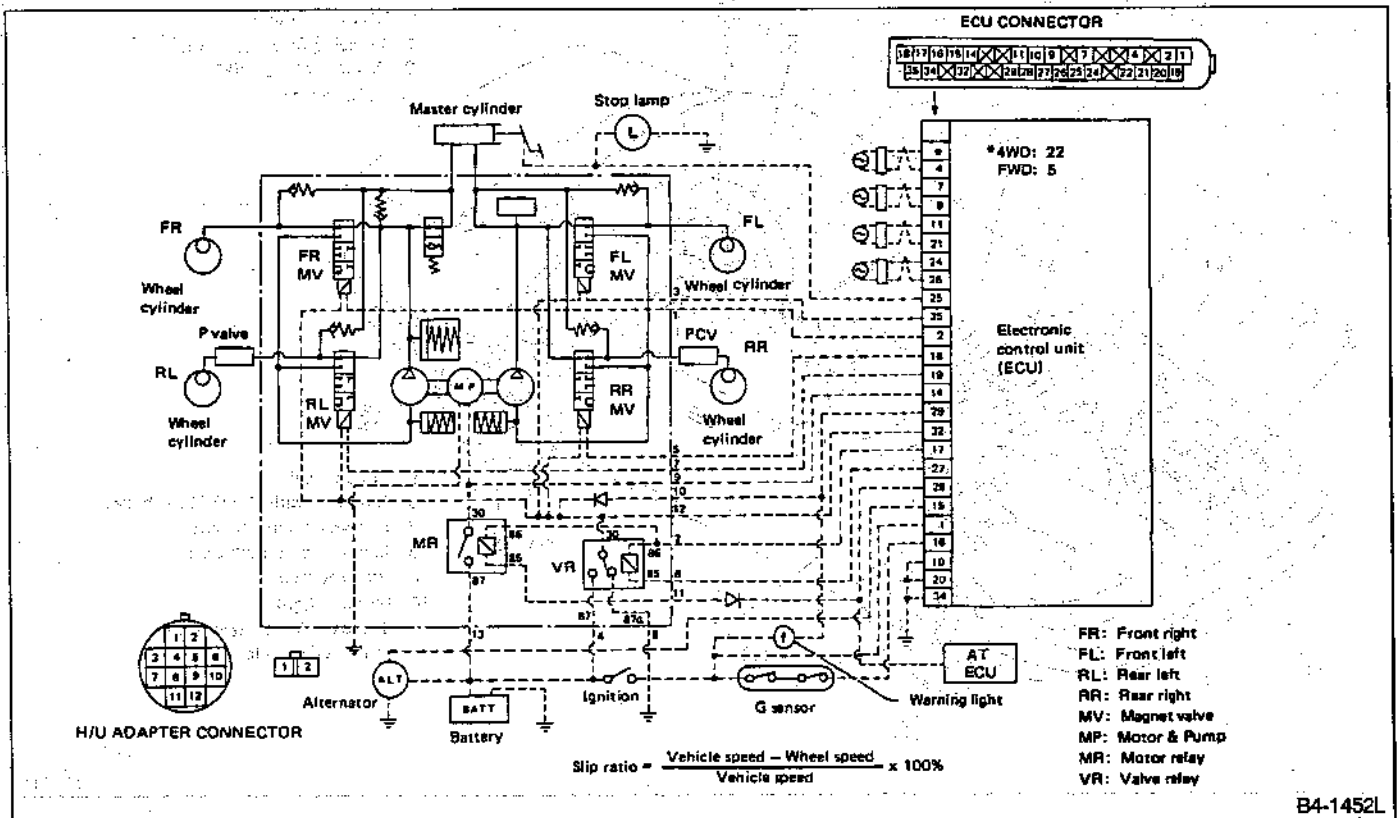


Fig. 32 ABS system diagram (BOSCH ABS)

3. THEORY OF ABS CONTROL

When the brake pedal is depressed during operation, wheel speed as well as vehicle speed decreases. The difference which occurs between wheel speed and vehicle speed is called the "slip" phenomenon. The magnitude of this action is expressed by "slip" the ratio which is determined by the following equation:

$$\text{Slip ratio} = \frac{\text{Vehicle speed} - \text{Wheel speed}}{\text{Vehicle speed}} \times 100\%$$

When the "slip" ratio is 0% vehicle speed equals wheel speed and the wheel rotates without any slippage. When the "slip" is 100% the wheel locks and does not rotate (wheel speed = 0) although vehicle speed exists. The relationship between the frictional force of a wheel in the fore-and-aft direction and the "slip" ratio is shown by two characteristic curves in Figure 33.

These curves are determined by the relationship between the wheel and road surface. Where the same type of wheel are used; the curve shown by a solid line indicates wheels driven on asphalt or paved roads, the curve shown by dotted lines refers wheels subjected to slippery (snowy or icy) roads.

When different types of wheels are used, although the road surface is the same, these curves will change. In general, the frictional coefficient between wheel and road surface in relation to an increase in the "slip ratio" will reach the maximum value in the 8—30% range and will tend to decrease after that.

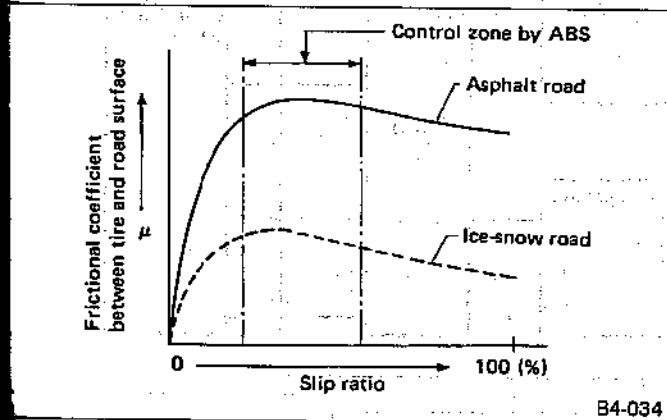


Fig. 33

B: CONSTRUCTION AND OPERATION

1. ABS SENSOR

The ABS sensor detects wheel speed and consists of a permanent magnet, coil, tone wheel, etc. The magnetic flux produced by the permanent magnet varies with the tone wheel (which rotates together with the wheel) and the sensor emits an alternating voltage corresponding with the wheel speed by electromagnetic induction.

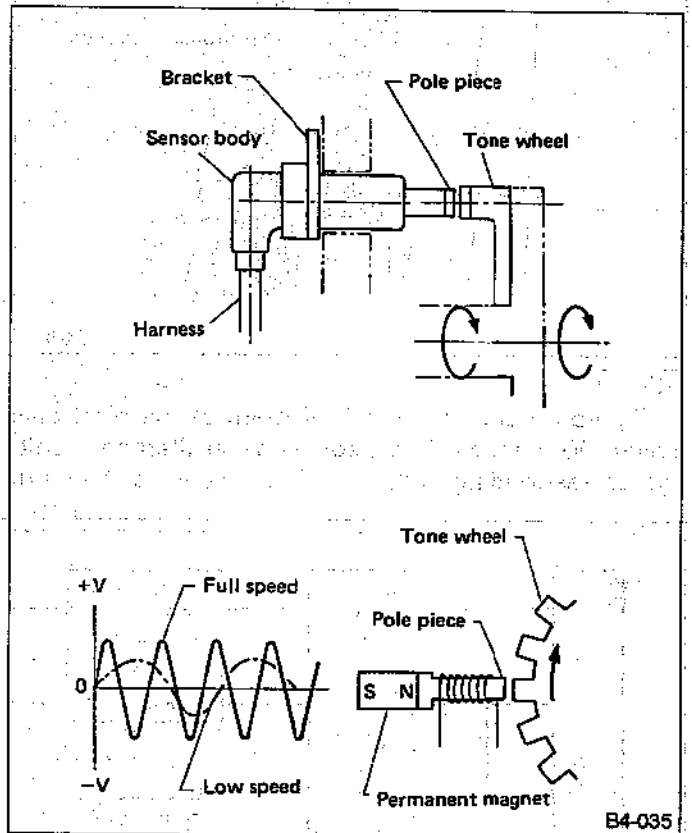


Fig. 34

2. ELECTRONIC CONTROL UNIT (E.C.U.)

1) The electronic control unit is a digital type that utilizes LSI elements to achieve compact structure and improve circuit reliability.

It consists of an arithmetic circuit, control circuit, signal input-output circuits, a safety circuit and a regulated power circuit. All these circuits are housed in the case located on the PC board.

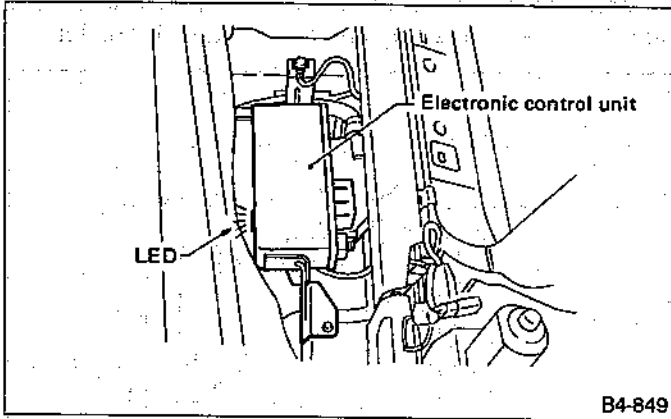


Fig. 35

2) Figure 36 shows a block diagram of the electronic circuits. When the ABS sensor sends an alternating voltage corresponding with the wheel speed to the input

amplifier circuit, the signal voltage is converted into a rectangular wave which is sent to the digital signal generating circuit. (This circuit receives two channels of signal at a time.)

The LSI circuit, which consists of approximately 16,000 transistors, computes wheel speed in relation to the signal sent from the ABS sensor. It then emits the required control signal as a result of computation. This circuit also contains a safety circuit for monitoring purposes. The control signal emitted from the LSI circuit is then sent to the current-control and -amplification circuits where a signal is produced to operate the magnet valve of the hydraulic control unit.

The memory circuit, which serves to memorize system failure, and monitor the regulated power circuit and others, is housed in a separate IC. When the E.C.U. power is applied with the ignition switch "ON", the safety circuit begins to monitor electronic circuits, sensors, the hydraulic control unit, etc. If any circuits or units malfunction, a warning light (dual circuit design) comes on to warn the driver of a problem. The LED in the ECU illuminates to show a trouble code. The brake system then functions as a conventional brake system in place of the ABS.

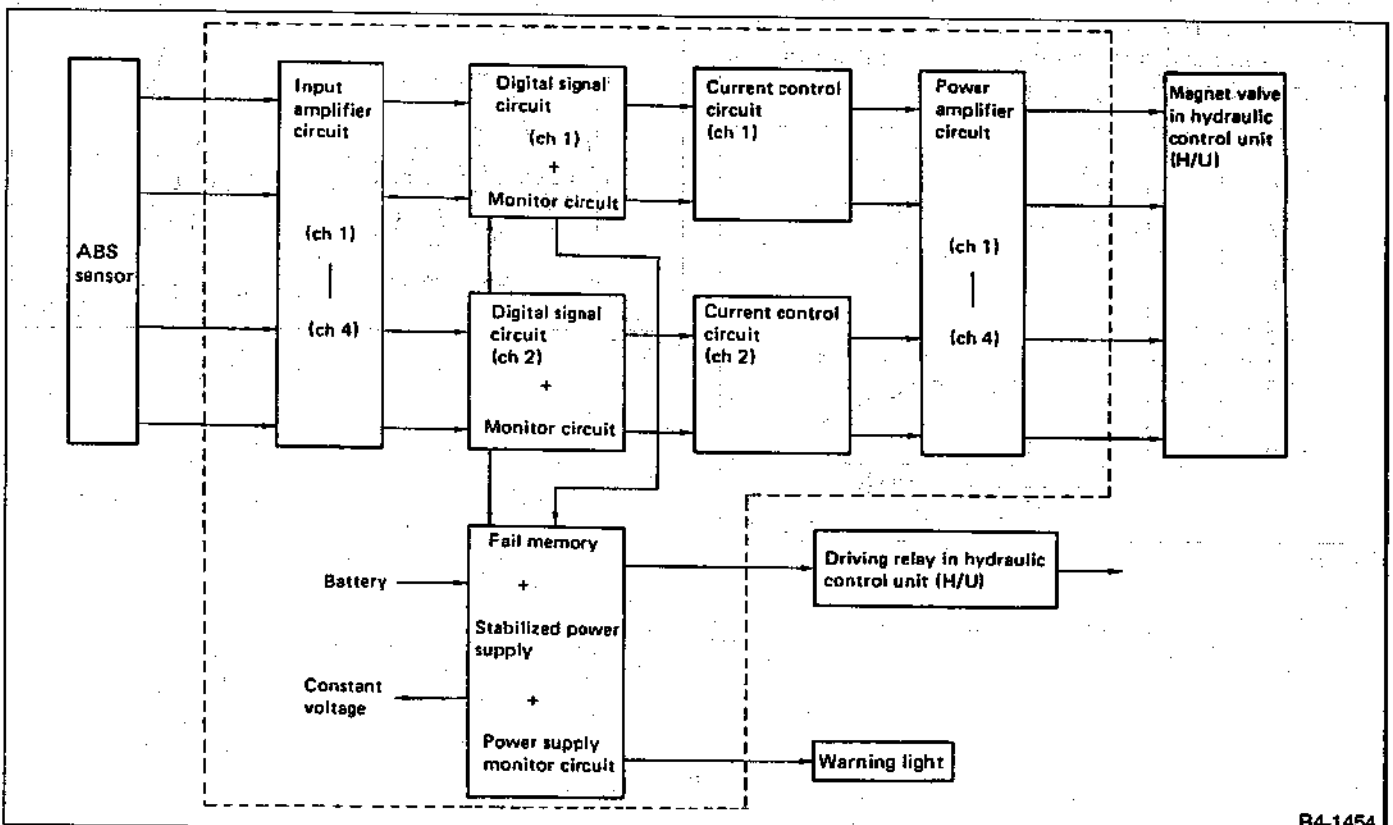


Fig. 36

B4-1454

3. ABS CONTROL CYCLE CURVES

As the brake pedal is depressed, brake fluid pressure increases correspondingly, which in turn decreases wheel speed. When brake fluid pressure reaches point "A" (where wheel deceleration exceeds $-b_0$), the control unit transmits a "hold" signal to hold the brake fluid pressure in wheel cylinder at that point. At the same time, the control unit computes a "dummy" vehicle speed. When the wheel speed drops below the slip-ratio setting (= speed less than the dummy vehicle speed) at point "B" of the brake fluid pressure, the control unit then transmits a "decrease" signal to prevent wheel lock-up. This causes the brake fluid pressure to decrease. After brake fluid pressure is decreased, wheel acceleration increases. When it exceeds the wheel acceleration

setting $+b_{10}$ at point "C" (brake fluid pressure), the control unit transmits a "hold" signal to hold the brake fluid pressure at that point. When wheel acceleration setting value $+b_{10}$ is exceeded and when brake fluid pressure is at point "D", the control unit judges that wheel lockup will not occur and then transmits an "increase" signal to increase brake fluid pressure. When wheel acceleration drops below $+b_0$ at point "E" (which occurred due to a brake fluid pressure increase), the repetition of the "hold" and "increase" signals takes place a at constant cycle. When wheel deceleration exceeds $-b_0$, at point "F" of the brake fluid pressure, the control unit immediately transmits a "decrease" signal to decrease brake fluid pressure.

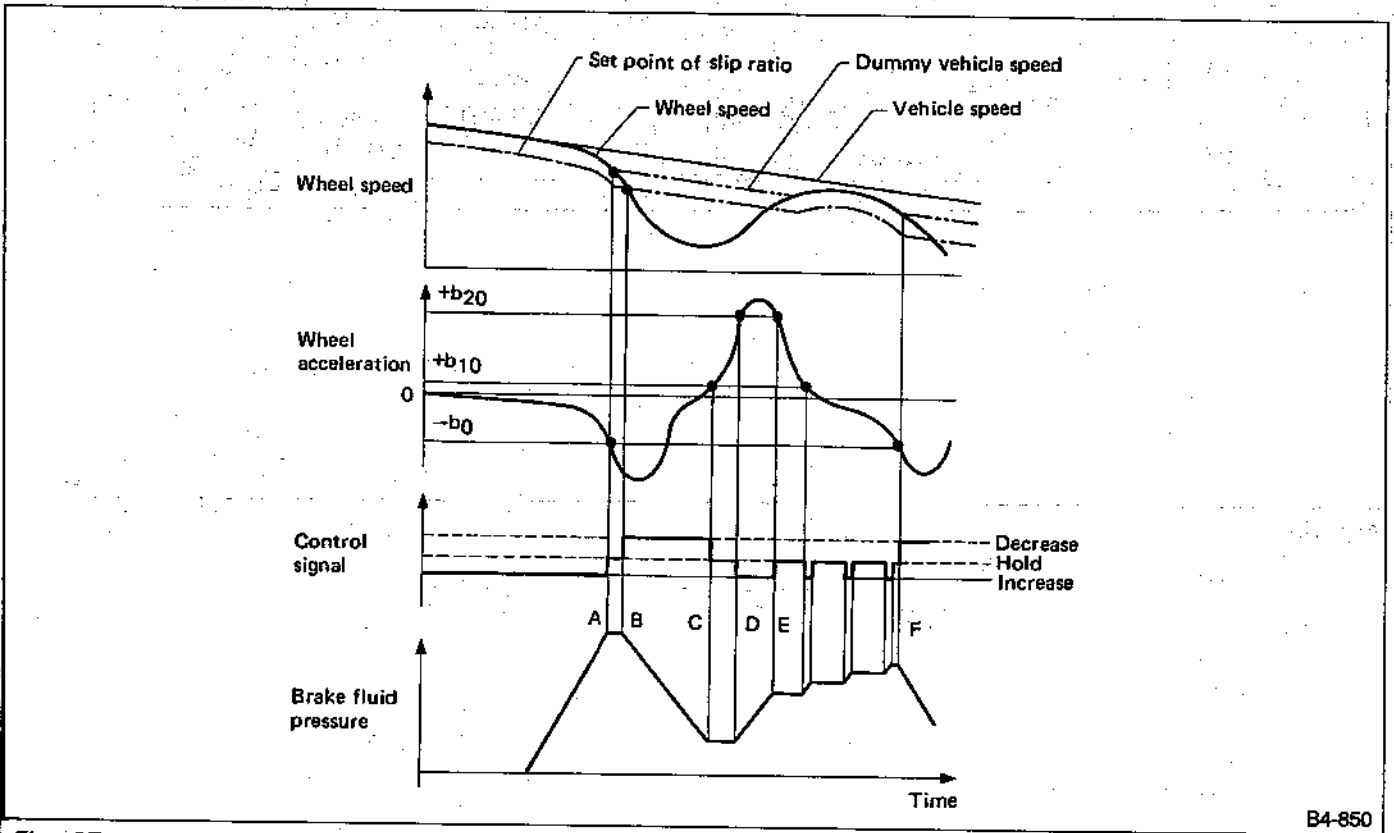


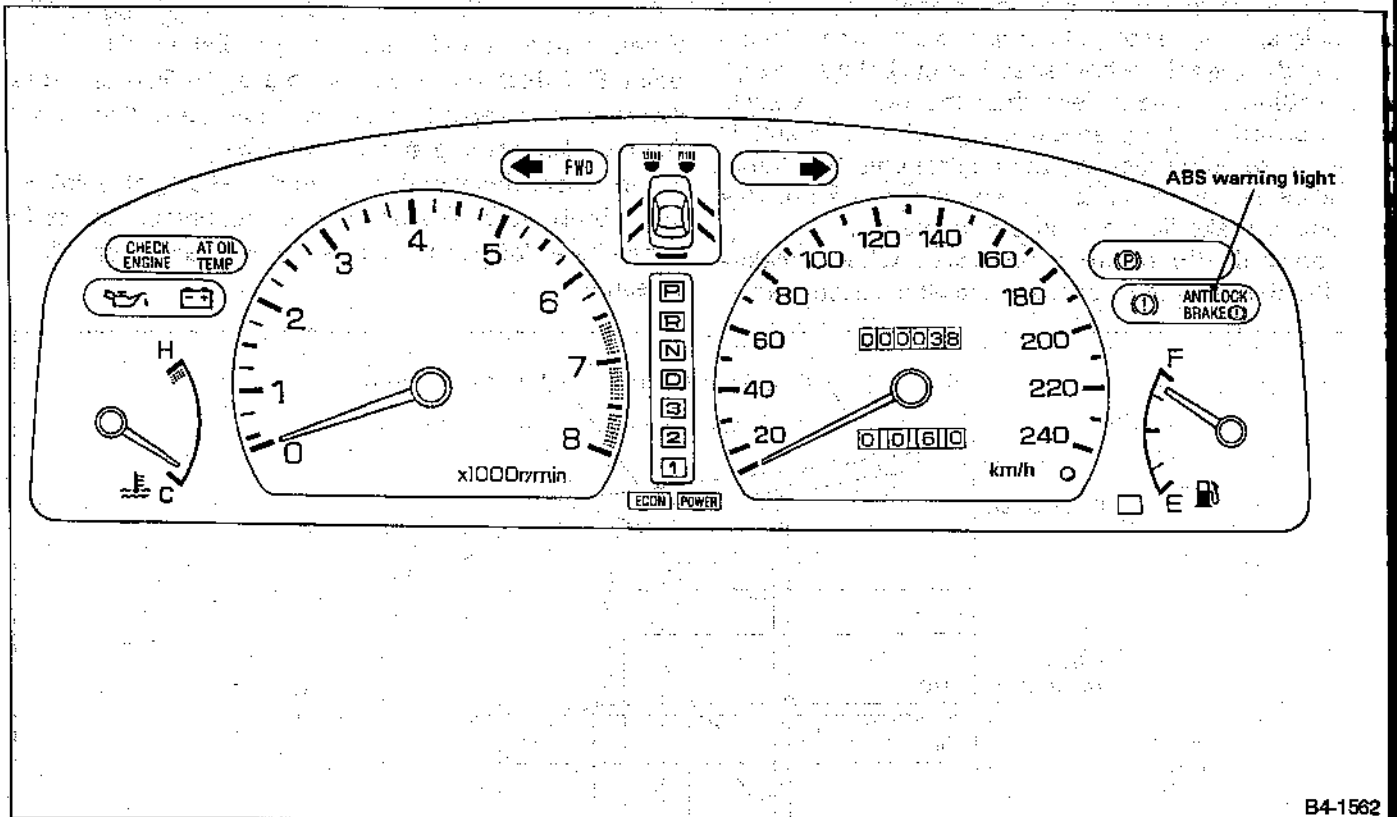
Fig. 37

B4-850

4. ABS WARNING LIGHT

When a signal system or the electronic control unit (E.C.U.) becomes inoperative, the warning light in the instrument panel comes on to indicate that the system or control unit is malfunctioning. At the same time, current flowing through the hydraulic control unit is inter-

rupted so that the brake system functions as a conventional brake system. The circuit through which the warning light comes on utilizes a dual system design. If the warning light comes on upon detection of a system malfunction, the control unit's LED also shows a trouble code.



B4-1562

Fig. 38

5. HYDRAULIC CONTROL UNIT

The hydraulic control unit is a fluid pressure control assembly which is composed of an electric motor, a plunger pump, a damper, a housing, a magnet valve and a relay.

There are two types of hydraulic control unit. One is manufactured by Nippon ABS, LTD. under license from ROBERT BOSCH GmbH, and the other is manufactured by ROBERT BOSCH GmbH. Both hydraulic control units are very similar to each other. The BOSCH type hydraulic control unit does not have the F-valve but has brake pedal "kick back" instead.

(NIPPON ABS)

1) During normal braking

When the brake pedal is depressed, fluid pressure is delivered from master cylinder ① to magnet valve ④ via F-valve ② while moving the ball up. Since current does not flow through the magnet valve, fluid pressure is delivered to wheel cylinder ⑫ so that normal braking force occurs.

Fluid pressure delivered to the F-valve ② also reaches outlet valve ⑧ which is sealed by the ball.

Accumulator ⑪ has its spring set to act by high fluid pressure, and not by normal fluid pressure. When cur-

rent does not flow through the magnet valve, the outlet port is sealed so that the oil passage to reservoir ⑤ is not linked.

When the brake pedal is released, master cylinder ① fluid pressure will decrease. Wheel cylinder ⑫ pressure will then return to the master cylinder ① while pushing the ball of check valve ③. At this point, F-valve ② is moved up by the ball to prevent wheel cylinder ⑫ pressure from returning to the master cylinder ①.

However, when master cylinder ① pressure drops below approximately 981 kPa (10 kg/cm², 142 psi), the F-valve ②'s return spring is moved to the left to push the ball up. This allows a slight amount of residual pressure (applied to check valve ③) to be delivered to wheel cylinder ⑫ via magnet valve ④.

When the brake pedal is slightly released while the ABS is operating, excess wheel cylinder fluid pressure returns to the master cylinder via check valve ③ so that wheel cylinder fluid pressure is balanced with master cylinder fluid pressure.

During the time the excess wheel cylinder fluid pressure returns to the master cylinder, the driver may feel a pedal "kickback".

This is not an indication of a problem.

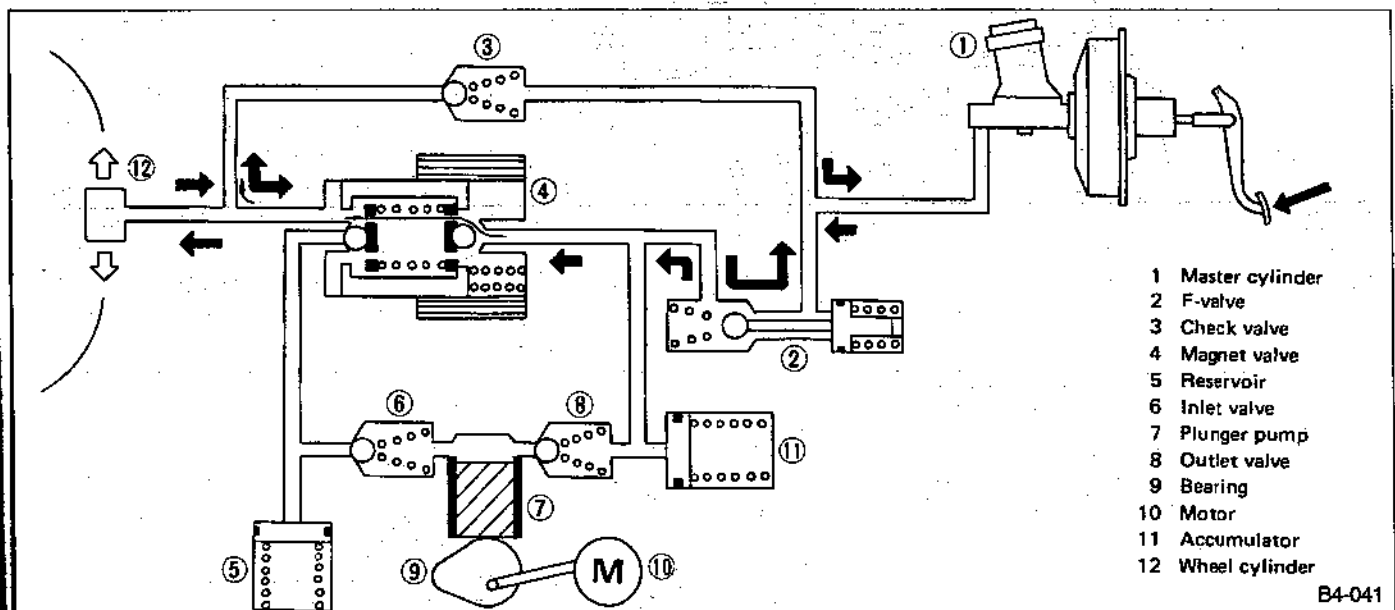


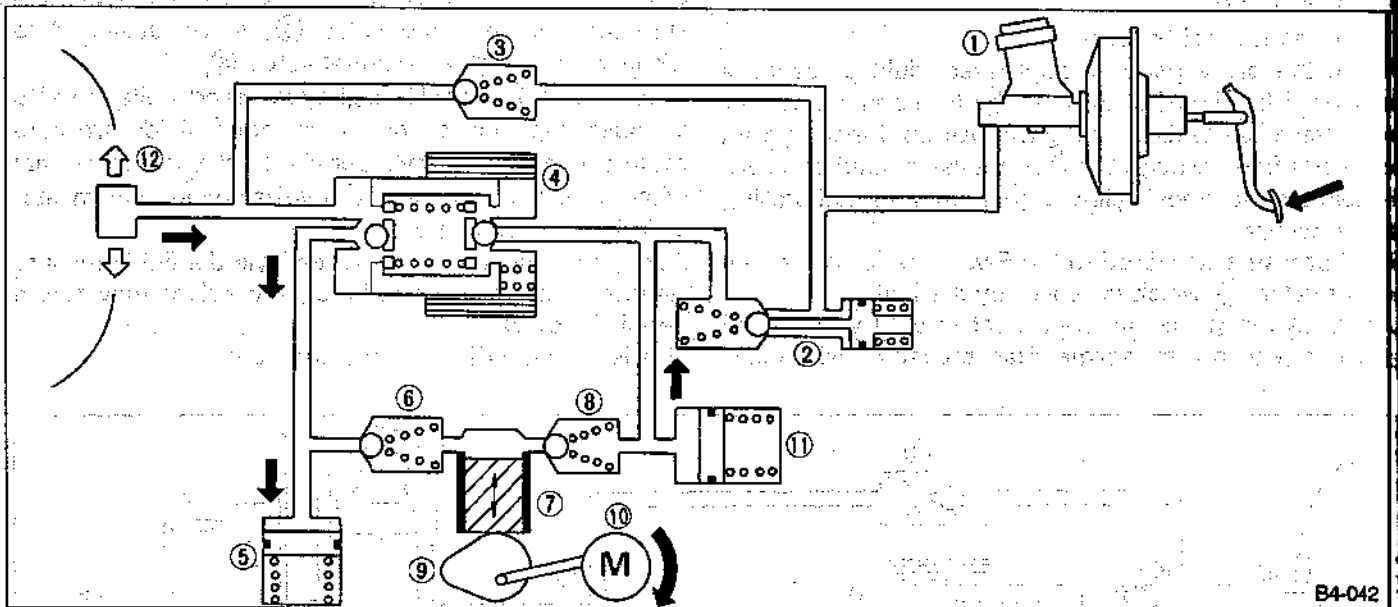
Fig. 39

B4-041

2) Pressure-decrease action with ABS in operation: When the wheels begin to lock during brake application, the E.C.U. emits an instruction so that a current of 4.8 to 6 amperes (which decreases fluid pressure) flows through magnet valve ④.

This closes the inlet port of the magnet valve ④ and opens the outlet port so that wheel cylinder ⑫ pressure is delivered to reservoir ⑤ via the outlet port. Since current also flows through the motor ⑩ (simultaneously when the current flows through the magnet valve), motor ⑩ will start to activate the plunger pump ⑦ via the bearing ⑨ (provided with an eccentric

cam) connected to it. Brake fluid pressure delivered to reservoir ⑤ then passes through inlet valve ⑥ and is increased by plunger pump ⑦. Increased brake fluid then passes through inlet valve ⑥ and is stored in accumulator ⑪. At this point, the increased brake fluid pressure is sealed by the ball of valve F ② to shut out the fluid pressure in master cylinder ①. Fluid pressure in wheel cylinder ⑫ also shuts out the fluid pressure in the master cylinder ① by means of check valve ③. Wheel cylinder ⑫ fluid pressure will then decrease to prevent the brake pedal from kicking back while it is being controlled to accommodate vehicle deceleration.

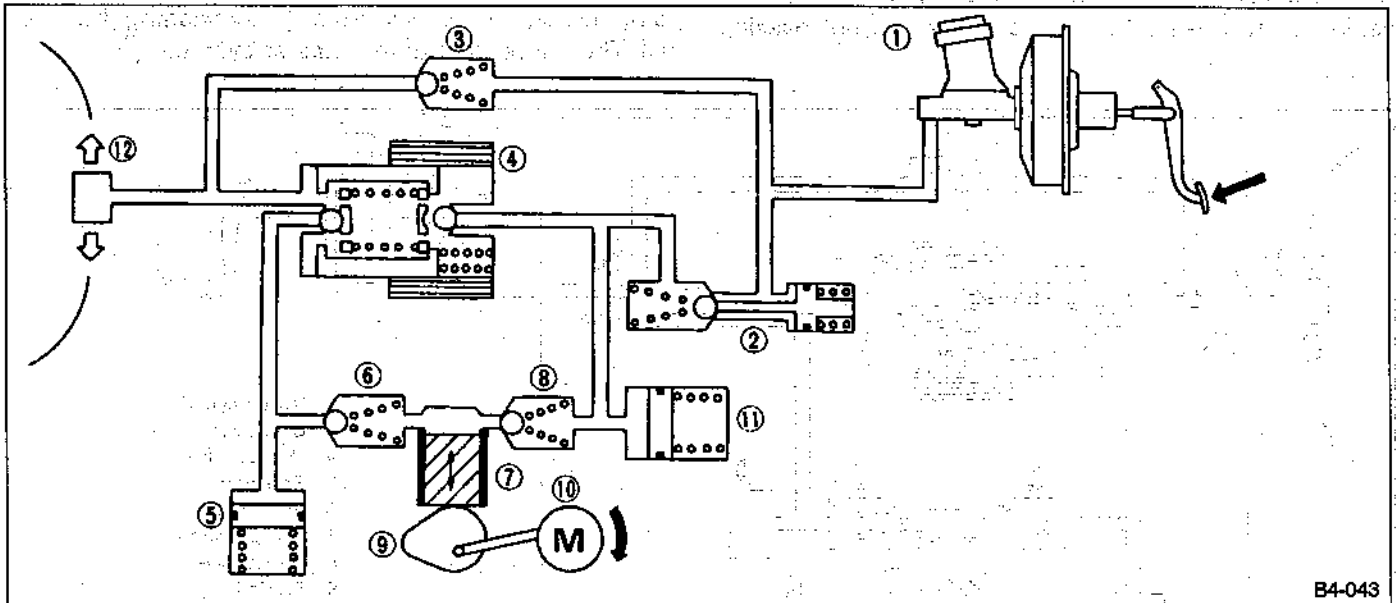


B4-042

Fig. 40

3) Pressure "hold" action with ABS in operation. When wheel cylinder ⑫ fluid pressure is decreased or increased to the optimum point, the controller emits an instruction so that a hold current of 1.9 to 2.3 amperes flows through magnet valve ④. The inlet and outlet ports will then be closed. At this point, the controlled

fluid pressure is held in the wheel cylinder ⑫, the fluid pressure increased by the pump (which increases the decreased wheel cylinder) is stored in accumulator ⑪, the fluid pressure increased by brake pedal depression force is held in master cylinder ① and the fluid pressure discharged from the pump is held in reservoir ⑤.

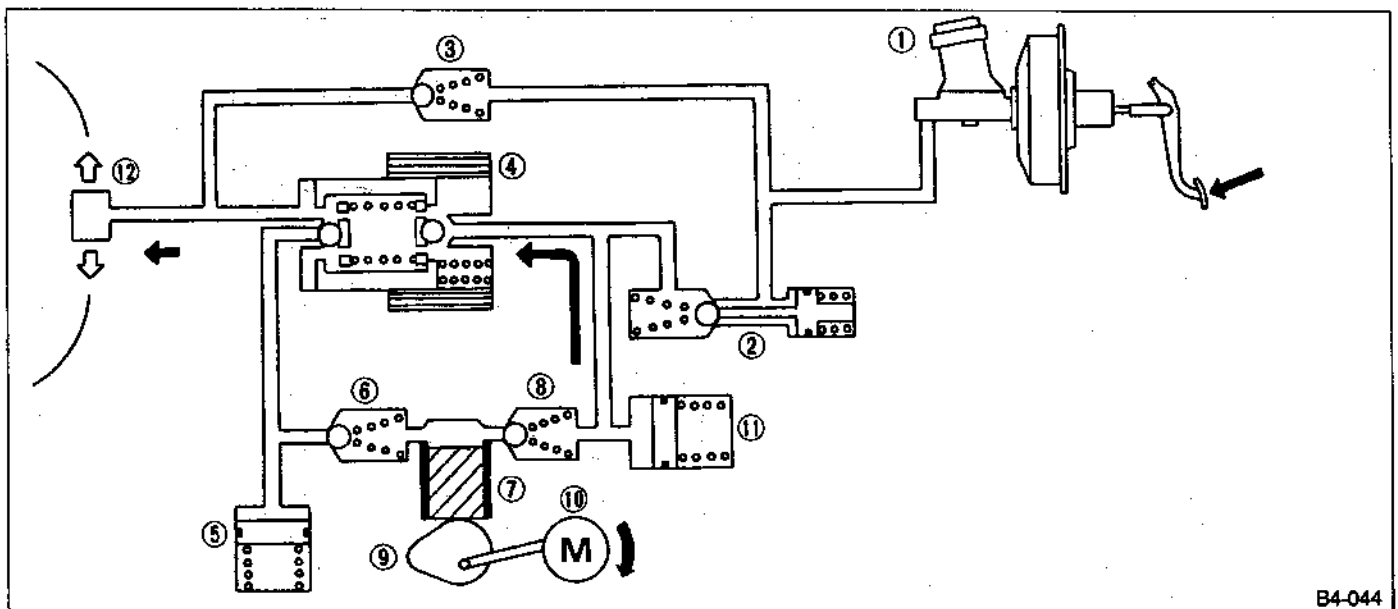


B4-043

Fig. 41

4) Pressure-increase action with ABS in operation. When current flowing through magnet valve ④ is interrupted (OFF) by an instruction emitted from the E.C.U., the fluid pressure of wheel cylinder ⑫ is increased. (At this point, internal passages of the magnet valve function is the same as in a conventional brake system.) When the magnet valve ④ is OFF, the inlet port is opened and the outlet port is closed. High fluid pres-

sure is then delivered from accumulator ⑪ to wheel cylinder ⑫ via the inlet port so that wheel cylinder pressure is increased. Since check valve ③ and F-valve ② remain sealed by the fluid pressure of master cylinder ① and high fluid pressure of accumulator ⑪ respectively, only wheel cylinder ⑫ fluid pressure is increased. Accordingly, a sensation of brake pedal "pull" will not occur.



B4-044

Fig. 42

(BOSCH ABS)

1) During normal braking

When the brake pedal is depressed, the brake fluid in the master cylinder ① goes through the magnet valve ④, and is delivered to the wheel cylinder ⑫, so that a normal braking force occurs. At the same time, the fluid pressure also reaches the outlet valve ⑧ which is sealed by the ball. At this time, current is not passing

through the magnet valve ④, and so the oil passage to reservoir ⑤ is clogged by the magnet valve ④ and the outlet valve ⑧.

When the brake pedal is released, the fluid pressure in the master cylinder ① will decrease. The fluid in the wheel cylinder ⑫ is pushed back. This fluid goes through the magnet valve ④, at the same time, as going through the check valve ③ by pushing the inner ball. Then, it returns to the master cylinder ①.

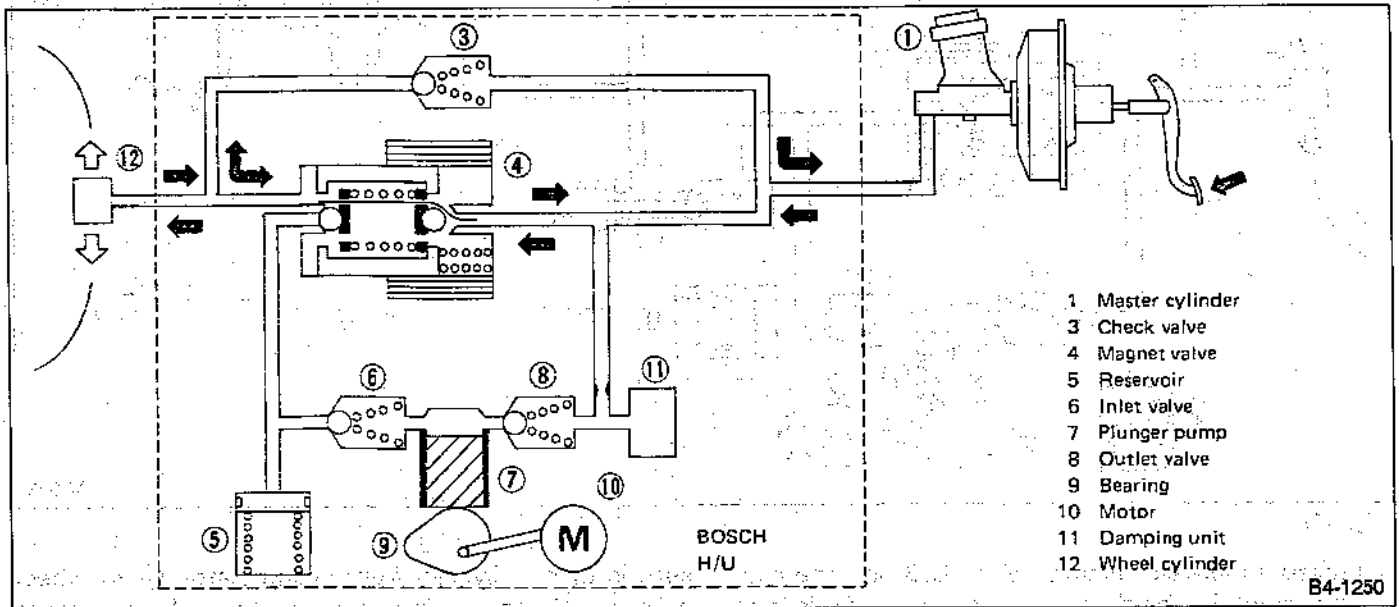


Fig. 43

2) Pressure-decrease action with ABS in operation
 When the wheels begin to lock during brake operation, the E.C.U. emits an instruction so that a current of 4.8 to 6 amperes flows through magnet valve ④. This operation closes the inlet port of the magnet valve ④ and opens the outlet port so that wheel cylinder ⑫ pressure is delivered to reservoir ⑤ via the outlet port. Brake fluid pressure delivered to reservoir ⑤ then passes through inlet valve ⑥ and is increased by

plunger pump ⑦. This causes "kick-back" of the brake pedal. Damping unit ⑪ reduces the pulse flow caused by plunger pump ⑦.
 The fluid pressure in wheel cylinder ⑫ is shut off from the fluid pressure in master cylinder ① by means of check valve ③. This prevents master cylinder pressure from flowing into the wheel cylinder. Wheel cylinder ⑫ fluid pressure will then decrease to prevent the wheel lock.

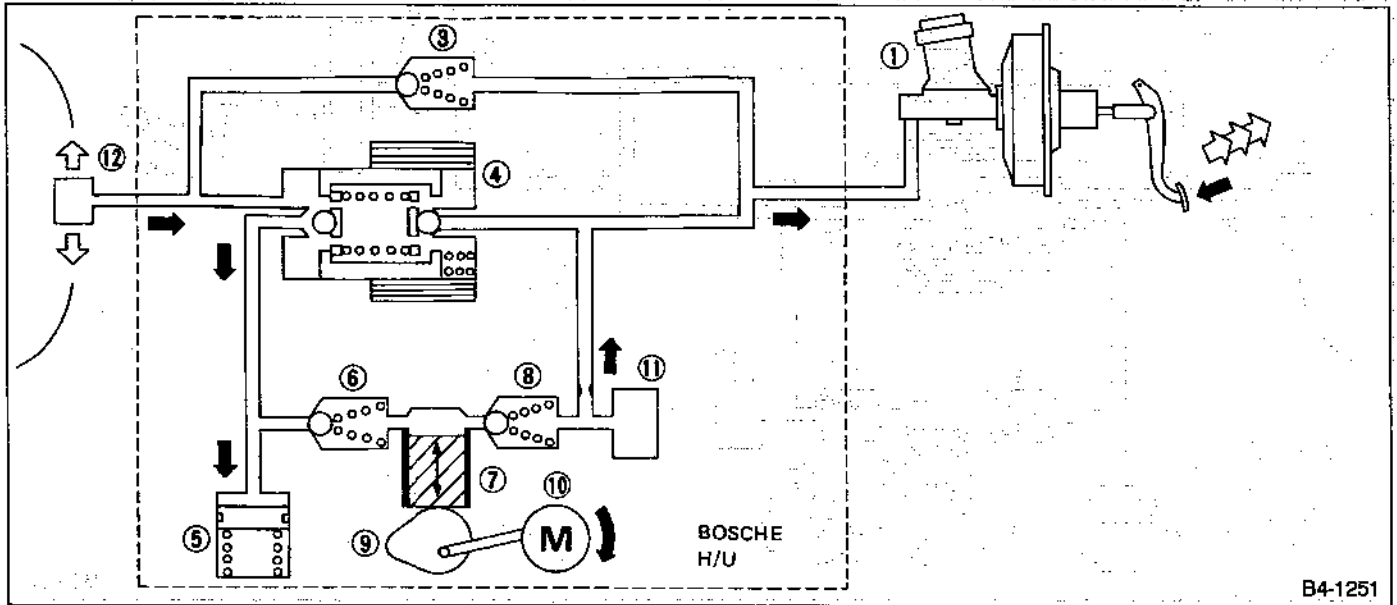


Fig. 44

3) Pressure "hold" action with ABS in operation
 When wheel cylinder ⑫ fluid pressure is decreased or increased to the optimum point, the controller emits an instruction so that a hold current of 1.9 to 2.3 amperes flows through magnet valve ④. The inlet and outlet ports will then be closed. At this point, the controlled

fluid pressure is held in the wheel cylinder ⑫, the fluid pressure increased by the pump (which increases the decreased wheel cylinder) is stored in accumulator ⑪, the fluid pressure increased by brake pedal depression force is held in master cylinder ① and the fluid pressure discharged from the pump is held in reservoir ⑤.

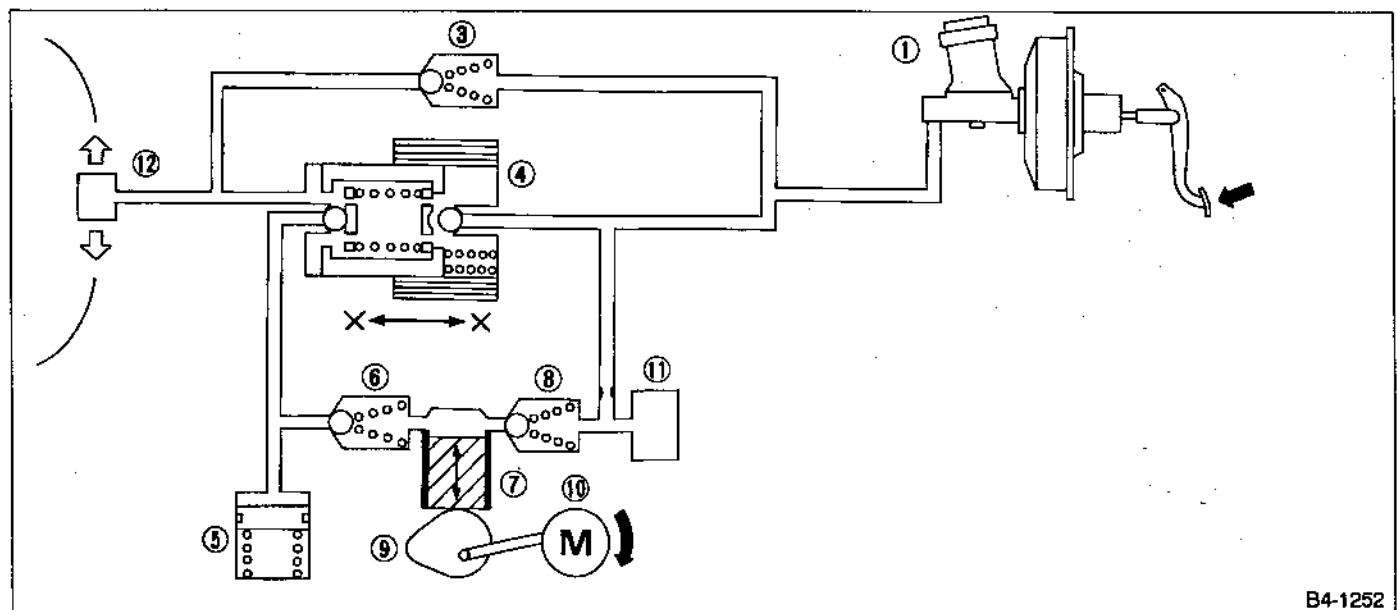
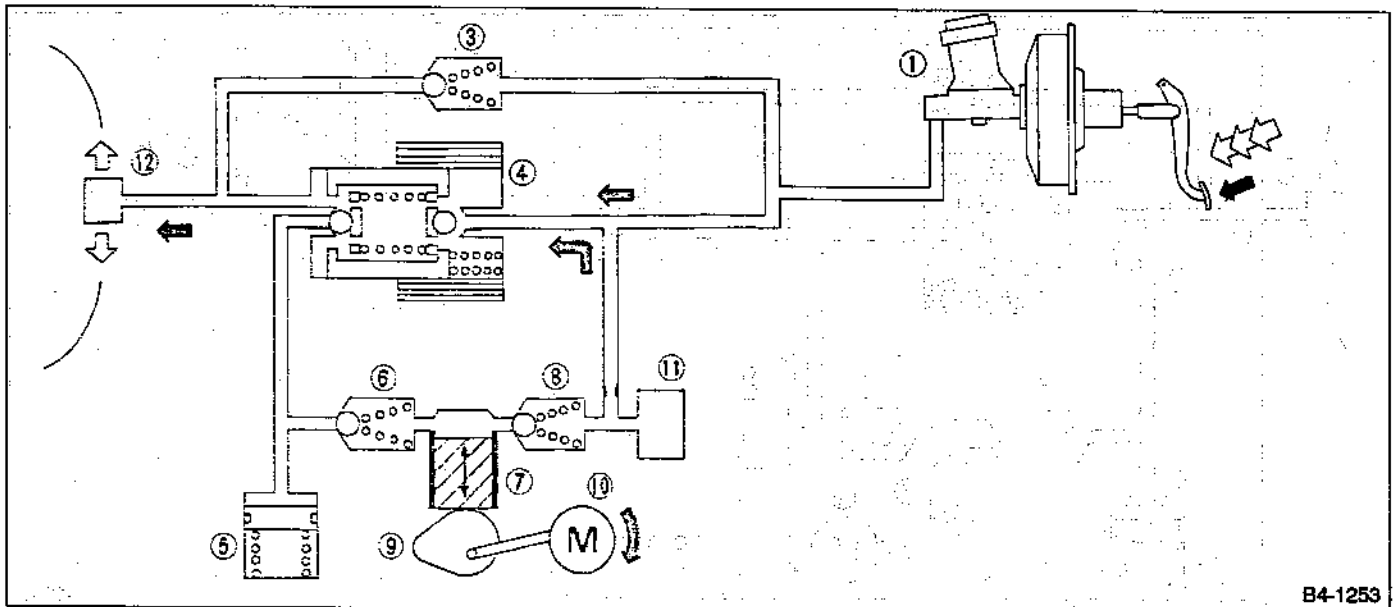


Fig. 45

4) Pressure-increase action with ABS in operation
 When current flowing through magnet valve ④ is interrupted (OFF) by an instruction emitted from the E.C.U., the fluid pressure of wheel cylinder ⑫ is increased. At this time, the magnet valve position is the same as the normal braking position. When magnet valve ④ is OFF, the inlet port is opened and the outlet port is closed.

High fluid pressure caused by the force on the brake pedal is then delivered to wheel cylinder ⑫ via the inlet port so that wheel cylinder pressure is increased.



B4-1253

Fig. 46

9. Parking Brake (Rear Disc Brake)

A: OUTLINE

The rear disc brake has its parking brake drum housed in the disc rotor for improved performance.

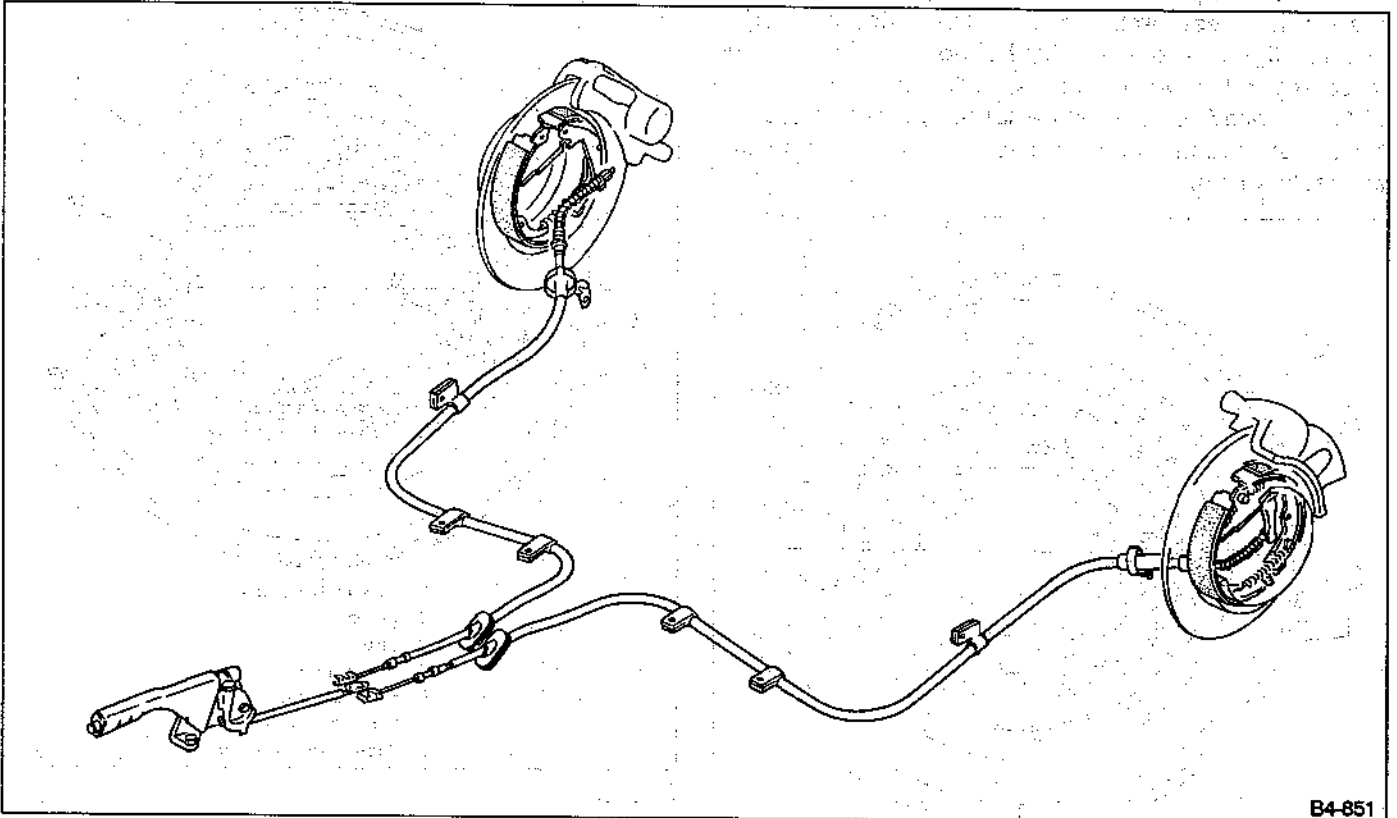


Fig. 47

B4-851

B: OPERATION**1. PARKING BRAKE APPLICATION**

When the parking brake lever is moved back, lever ② located on the end of the parking brake cable ① moves strut ③ in the direction of "A" with point "P" utilized as a fulcrum.

The strut then presses brake shoes ④ and ⑤ against the drum. These brake shoes utilize a floating design and are lightly supported by hold-down pins ⑦. The force applied to brake shoe ④, and the reaction force of "A" applied to brake shoe ⑤ via point "P" provide brake application when the shoes are pressed against the brake drum.

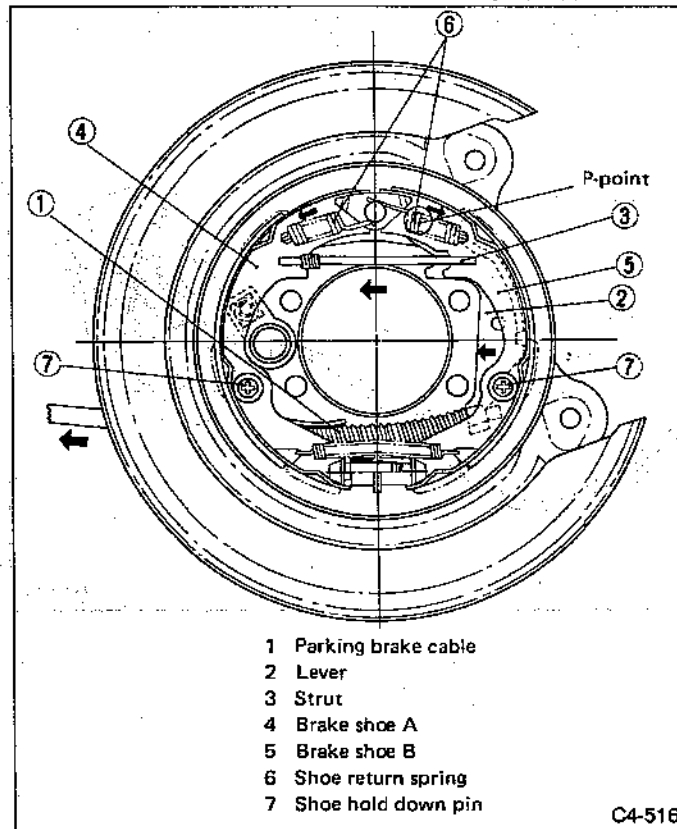


Fig. 48

2. PARKING BRAKE RELEASE

When the parking brake lever is moved forward, parking brake cable ① is loosened. This returns brake shoes ④ and ⑤ to their original position from the tension of return spring ⑥ so that the parking brake is released.

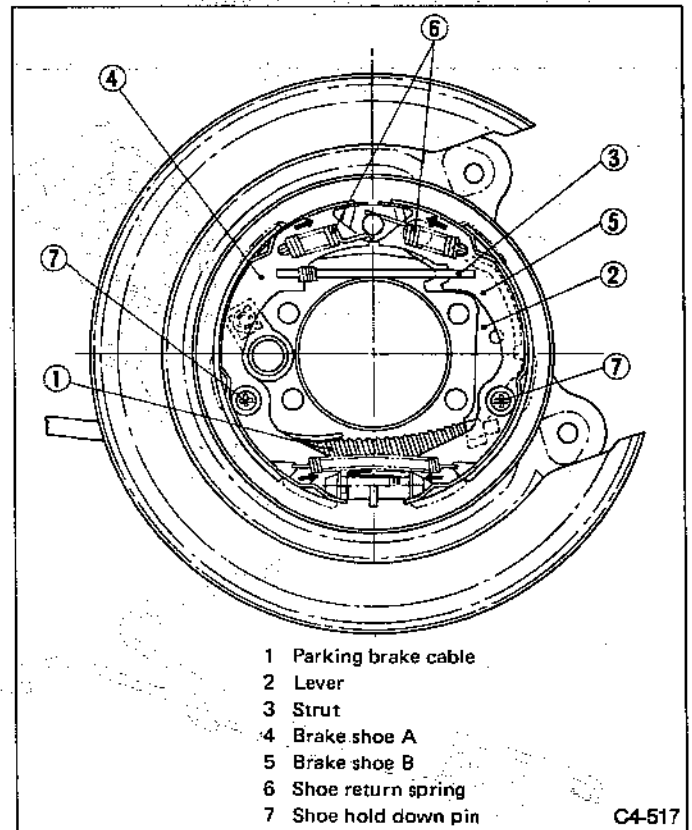


Fig. 49

S SPECIFICATIONS AND SERVICE DATA

A: SPECIFICATIONS

	Model	4-Door Sedan										
	Engine (cc)	1600		1800				2000		2200		
	Driving system	FWD				4WD		FWD	4WD		FWD	4WD
		DL	GL	DL	GL	DL	GL	GL	GL	TURBO	GX	GX
Front brake	Type	Disc (Floating type, ventilated)										
	Effective disc diameter mm (in)	194 (7.64)	210 (8.27)	194 (7.64)	210 (8.27)				228 (8.98)	210 (8.27)		
	Disc thickness x Outer diameter mm (in)	18 x 242 (0.71 x 9.53)	24 x 260 (0.94 x 10.24)	18 x 242 (0.71 x 9.53)	24 x 260 (0.94 x 10.24)				24 x 277 (0.94 x 10.91)	24 x 260 (0.94 x 10.24)		
	Effective cylinder diameter mm (in)	57.2 (2.252)							42.8 x 2 (1.685 x 0.08)	57.2 (2.252)		
	Pad dimensions (length x width x thickness) mm (in)	112.4 x 44.3 x 11.0 (4.43 x 1.744 x 0.433)							112.3 x 50 x 11 (4.42 x 1.97 x 0.43)	112.4 x 44.3 x 11.0 (4.43 x 1.744 x 0.433)		
	Clearance adjustment	Automatic adjustment										
Rear brake	Type	Drum (Leading-Trailing type)				Drum (Leading-Trailing type) [Disc (Floating type)]		Disc (float- ing type, venti- lated)	Disc (Floating type)			
	Effective drum or disc diameter mm (in)	228.6 (9)				228.6 (9) [230 (9.06)]		230 (9.06)	230 (9.06)			
	Disc thickness x Outer diameter mm (in)	—				— [10 x 266 (0.39 x 10.47)]		18 x 266 (0.71 x 10.47)	10 x 266 (0.39 x 10.47)			
	Effective cylinder diameter mm (in)	17.4 (0.685)				17.4 (0.685) [34.9 (1.374)]		38.1 (1.500)	34.9 (1.374)			
	Lining or pad dimensions (length x width x thickness) mm (in)	218.8 x 35.0 x 4.1 (8.61 x 1.378 x 0.161)				218.8 x 35.0 x 4.1 (8.61 x 1.378 x 0.161) [92.4 x 33.7 x 10.0 (3.638 x 1.327 x 0.394)]		92.4 x 33.7 x 10.0 (3.638 x 1.327 x 0.394)	92.4 x 33.7 x 10.0 (3.638 x 1.327 x 0.394)			
	Clearance adjustment	Automatic adjustment										

[]: ABS equipped vehicle

BRAKES

[SOA0] 4-4

	Model	Station Wagon						Touring Wagon						
	Engines (cc)	1600		1800		2000		1600	1800	2000		2200		
	Driving system	FWD			4WD			FWD	4WD	4WD		FWD	4WD	
		DL	DL	GL	DL	GL	DL	GL	GL	GL	TURBO	GL	TURBO	GX
Front brake	Type	Disc (Floating type, ventilated)												
	Effective disc diameter mm (in)	194 (7.64)			210 (8.27)						228 (8.99)		210 (8.27)	
	Disc thickness x Outer diameter mm (in)	18 x 242 (0.71 x 9.53)			24 x 260 (0.94 x 10.24)						24 x 277 (0.94 x 10.91)		24 x 260 (0.94 x 10.24)	
	Effective cylinder diameter mm (in)	57.2 (2.252)						42.8 x 2 (1.685 x 0.08)		52.2 (2.055)				
	Pad dimensions (length x width x thickness) mm (in)	112.4 x 44.3 x 11.0 (4.43 x 1.744 x 0.433)						112.3 x 50 x 11 (4.42 x 1.97 x 0.43)		112.4 x 44.3 x 11.0 (4.43 x 1.744 x 0.433)				
	Clearance adjustment	Automatic adjustment												
Rear brake	Type	Drum (Leading-Trailing type)			Drum (Leading-Trailing type) [Disc (Floating type)]			Drum (Leading-Trailing type)	Drum (Leading-Trailing type) [Disc (Floating type)]		Disc (floating type, ventilated)	Disc (Floating type)		
	Effective drum or disc diameter mm (in)	228.6 (9)			228.6 (9) [230 (9.06)]			228.6 (9)	228.6 (9) [230 (9.06)]		230 (9.06)	230 (9.06)		
	Disc thickness x Outer diameter mm (in)	—			[10 x 266 (0.39 x 10.47)]			—	[10 x 266 (0.39 x 10.47)]		18 x 266 (0.71 x 10.47)	10 x 266 (0.39 x 10.47)		
	Effective cylinder diameter mm (in)	19.0 (0.748)			19.0 (0.748) [38.1 (1.500)]			19.0 (0.748)	19.0 (0.748) [38.1 (1.500)]		38.1 (1.500)	38.1 (1.500)		
	Lining or pad dimensions (length x width x thickness) mm (in)	218.8 x 35.0 x 4.1 (8.61 x 1.378 x 0.161)			218.8 x 35.0 x 4.1 (8.61 x 1.378 x 0.161) [92.4 x 33.7 x 10.0 (3.638 x 1.327 x 0.394)]			218.8 x 35.0 x 4.1 (8.61 x 1.378 x 0.161)	218.8 x 35.0 x 4.1 (8.61 x 1.378 x 0.161) [92.4 x 33.7 x 10.0 (3.638 x 1.327 x 0.394)]		92.4 x 33.7 x 10.0 (3.638 x 1.327 x 0.394)	92.4 x 33.7 x 10.0 (3.638 x 1.327 x 0.394)		
	Clearance adjustment	Automatic adjustment												

[]: ABS equipped vehicle

	Model	4-Door Sedan											
	Engine (cc)	1600		1800				2000			2200		
	Driving system	FWD				4WD		FWD	4WD		FWD	4WD	
		DL	GL	DL	GL	DL	GL	GL	GL	TURBO	GX	GX	
Parking brake	Type	Mechanical on rear brakes, drum											
	Effective drum diameter mm (in)	228.6 (9)				228.6 (9) [170 (6.69)]				170 (6.69)			
	Lining dimensions (length x width x thickness) mm (in)	218.8 x 35.0 x 4.1 (8.61 x 1.378 x 0.161)				218.8 x 35.0 x 4.1 (8.61 x 1.378 x 0.161) [162.6 x 30.0 x 3.2 (6.40 x 1.181 x 0.126)]				162.6 x 30.0 x 3.2 (6.40 x 1.181 x 0.126)			
	Clearance adjustment	Automatic adjustment				Automatic adjustment [Manual adjustment]				Manual adjustment			
Master cyl- inder	Type	Tandem											
	Effective diameter mm (in)	23.81 (15/16)				23.81 (15/16) [26.99 (1-1/16)]				25.40 (1) [26.99 (1-1/16)]			
	Reservoir type	Sealed type											
	Brake fluid reservoir capacity cm ³ (cu in)	190 (11.59)											
Brake boost- er	Type	Vacuum suspended											
	Effective diameter mm (in)	230 (9.06)				230 (9.06) [205 + 230 (8.07 + 9.06)]				180 + 205 (7.09 + 8.07) [205 + 230 (8.07 + 9.06)]			
Pro- por- tioning valve	Split point kPa (kg/cm ² , psi)	3,678 (37.5, 533)				3,678 (37.5, 533) [3,678 (37.5, 533)]							
	Reducing ratio	0.3											
Brake line	Dual circuit system												
Hill-holder	Equipped on manual transmission vehicle (Except TURBO model)												
ABS	NA					OP							

[]: ABS equipped vehicle

BRAKES

[SOA0] 4

	Model	Station Wagon						Touring Wagon				
	Engine (cc)	1600	1800		2000		1600	1800	2000	2200		
	Driving system	FWD		4WD	FWD	4WD	FWD	4WD	4WD		FWD	4WD
		DL	DL	GL	DL	GL	DL	GL	GL	TURBO	GX	GX
Parking brake	Type	Mechanical on rear brakes, drum										
	Effective drum diameter mm (in)	228.6 (9)			228.6 (9) [170 (6.69)]		228.6 (9)	228.6 (9) [170 (6.69)]		170 (6.69)		
	Lining dimensions (length x width x thickness) mm (in)	218.8 x 35.0 x 4.1 (8.61 x 1.378 x 0.161)			218.8 x 35.0 x 4.1 (8.61 x 1.378 x 0.161) [162.6 x 30.0 x 3.2 (6.40 x 1.181 x 0.126)]		218.8 x 35.0 x 4.1 (8.61 x 1.378 x 0.161)	218.8 x 35.0 x 4.1 (8.61 x 1.378 x 0.161) [162.6 x 30.0 x 3.2 (6.40 x 1.181 x 0.126)]		162.6 x 30.0 x 3.2 (6.40 x 1.181 x 0.126)		
	Clearance adjustment	Automatic adjustment			Automatic adjustment [Manual adjustment]		Auto- matic adjust- ment	Automatic adjustment [Manual adjustment]		Manual adjustment		
Master cyl- inder	Type	Tandem										
	Effective diameter mm (in)	23.81 (15/16)			23.81 (15/16) [26.99 (1-1/16)]		23.81 (15/16)	23.81 (15/16) [26.99 (1-1/16)]		25.40 (1) [26.99 (1-1/16)]		
	Reservoir type	Sealed type										
	Brake fluid reservoir capacity cm ³ (cu in)	190 (11.59)										
Brake boost- er	Type	Vacuum suspended										
	Effective diameter mm (in)	230 (9.06)			230 (9.06) [205 + 230 (8.07 + 9.06)]		230 (9.06)	230 (9.06) [205 + 230 (8.07 + 9.06)]		180 + 205 (7.09 + 8.07) [205 + 230 (8.07 + 9.06)]		
Pro- por- tioning valve	Split point kPa (kg/cm ² , psi)	3,678 (37.5, 533)			3,678 (37.5, 533) [3,678 (37.5, 533)]		3,678 (37.5, 533)	3,678 (37.5, 533) [4,413 (45, 640)]		4,413 (45, 640) [4,413 (45, 640)]		
	Reducing ratio	0.3										
Brake line	Dual circuit system											
Hill-holder	Equipped on manual transmission vehicle (Except TURBO model)											
ABS	NA			OP		NA	OP					

[]: ABS equipped vehicle

B: SERVICE DATA

ITEM		STANDARD	SERVICE LIMIT
Front brake	Pad thickness (including back metal)	17 mm (0.67 in)	7.5 mm (0.295 in)
	Disc thickness	13-inch type: 18 mm (0.71 in) 14-inch type: 24 mm (0.94 in) 15-inch type: 24 mm (0.94 in)	13-inch type: 16 mm (0.63 in) 14-inch type: 22 mm (0.87 in) 15-inch type: 22 mm (0.87 in)
	Disc run-out	—	0.10 mm (0.0039 in)
Rear brake (Disc type)	Pad thickness (including back metal)	15 mm (0.59 in)	6.5 mm (0.256 in)
	Disc thickness	Solid type: 10 mm (0.39 in) Ventilated type: 18 mm (0.71 in)	Solid type: 8.5 mm (0.335 in) Ventilated type: 16 mm (0.63 in)
	Disc run-out	—	0.10 mm (0.0039 in)
Rear brake (Drum type)	Inside diameter	228.6 mm (9 in)	230.6 mm (9.079 in)
	Lining thickness	4.1 mm (0.161 in)	1.5 mm (0.059 in)
Rear brake (Disc type Parking)	Inside diameter	170 mm (6.69 in)	171 mm (6.73 in)
	Lining thickness	3.2 mm (0.126 in)	1.5 mm (0.059 in)
Parking brake	lever stroke	7 to 8 notches/196N (20 kg/44 lb)	

			DL*GL	GX	TURBO	DL*GL*GX with ABS	TURBO with ABS
Brake booster	Brake fluid pressure without engine running	Brake pedal force	Fluid pressure				
		147N (15 kg, 33 lb)	785 kPa (8 kg/cm ² , 114 psi)	588 kPa (6 kg/cm ² , 85 psi)	588 kPa (6 kg/cm ² , 85 psi)	588 kPa (6 kg/cm ² , 85 psi)	588 kPa (6 kg/cm ² , 85 psi)
	294N (30kg, 66 lb)	2,158 kPa (22 kg/cm ² , 313 psi)	1,863 kPa (19 kg/cm ² , 270 psi)	1,863 kPa (19 kg/cm ² , 270 psi)	1,667 kPa (17 kg/cm ² , 242 psi)	1,667 kPa (17 kg/cm ² , 242 psi)	
	Brake fluid pressure with engine running and vacuum at 66.7 kPa (500 mmHg, 19.69 inHg)	147N (15 kg, 33 lb)	5,492 kPa (56 kg/cm ² , 796 psi)	5,394 kPa (55 kg/cm ² , 782 psi)	4,904 kPa (50 kg/cm ² , 711 psi)	5,394 kPa (55 kg/cm ² , 782 psi)	5,002 kPa (51 kg/cm ² , 725 psi)
294N (30kg, 66 lb)		8,434 kPa (86 kg/cm ² , 1,223 psi)	9,219 kPa (94 kg/cm ² , 1,337 psi)	9,219 kPa (94 kg/cm ² , 1,337 psi)	10,003 kPa (102 kg/cm ² , 1,450 psi)	10,003 kPa (102 kg/cm ² , 1,450 psi)	

C: RECOMMENDED BRAKE FLUID

FMVSS No. 116, fresh DOT3 or 4 brake fluid

- Avoid mixing brake fluid of different brands to prevent the fluid performance from degrading.
- When brake fluid is supplemented, be careful not to allow any dust into the reservoir.
- Use fresh DOT3 or 4 brake fluid when replacing or refilling the fluid.

D: BRAKE FLUID LEVEL INDICATOR

Reserve tank with level indicator:
Residual fluid quantity at light ON
Approx. 80 cm³ (80cc, 4.88 cu in)
Tank capacity
190 cm³ (190cc, 11.59 cu in)

C COMPONENT PARTS

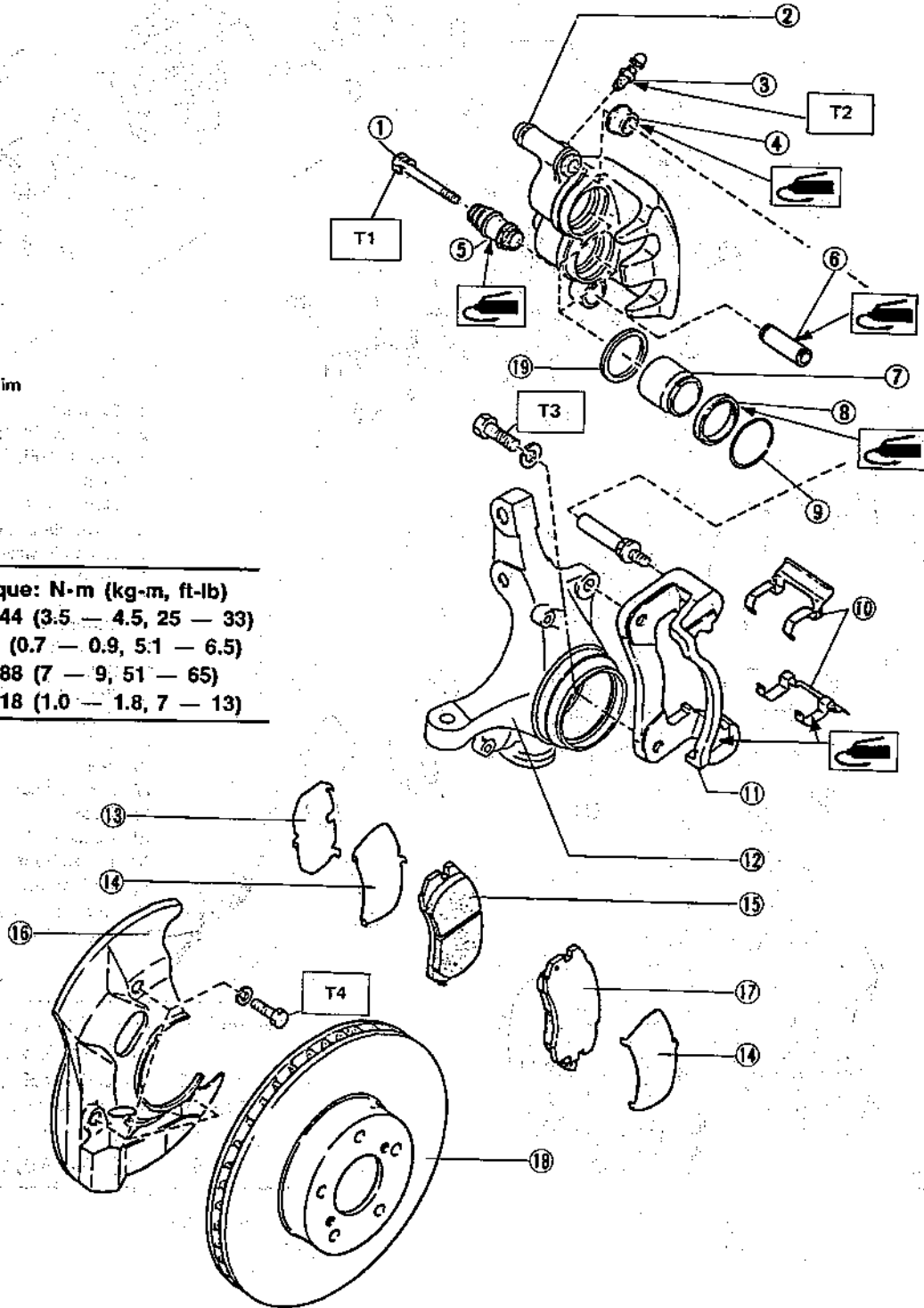
1. Front Disc Brake

1. TURBO MODEL

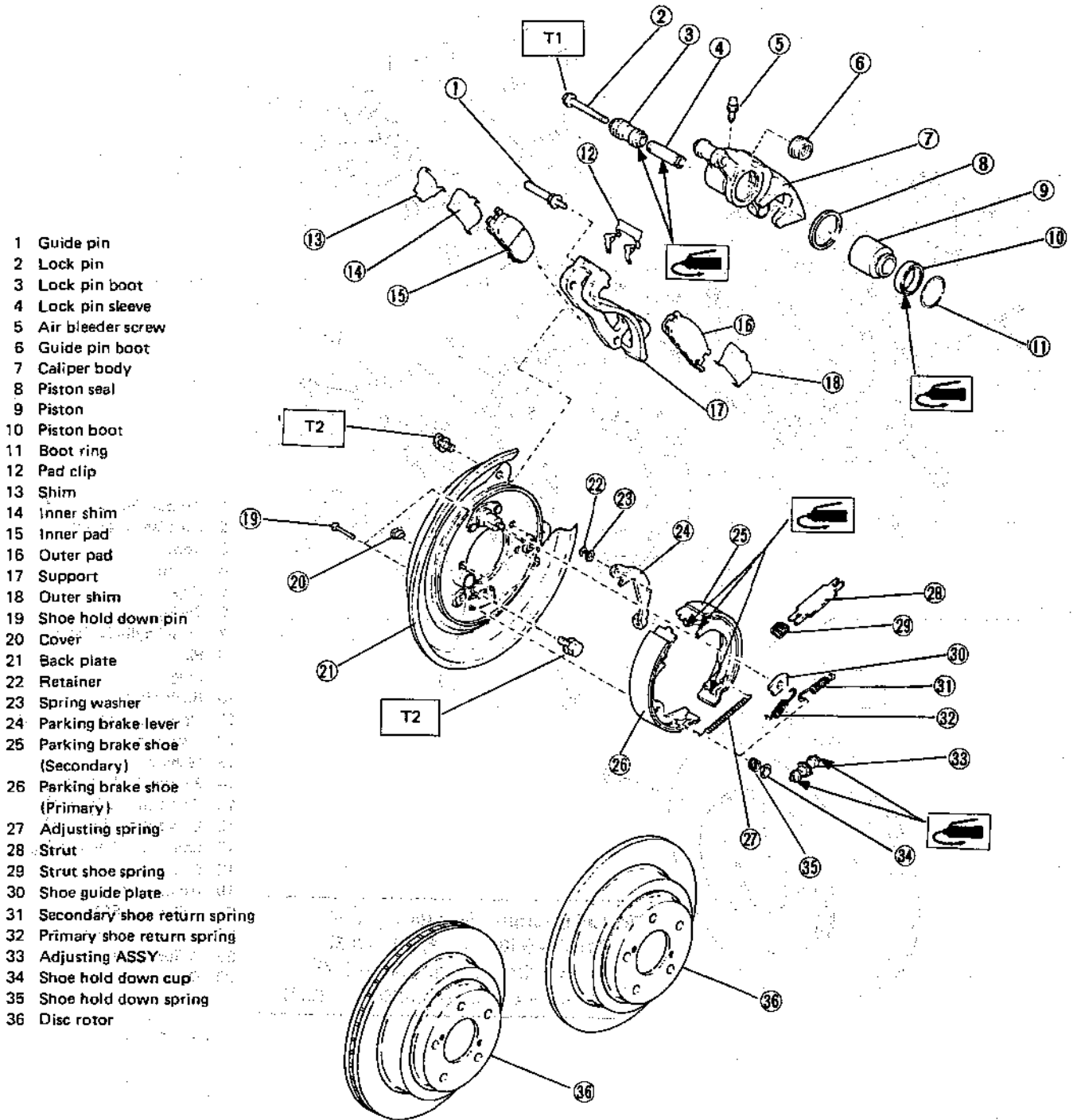
- 1 Lock pin
- 2 Caliper body
- 3 Air bleeder screw
- 4 Guide pin boot
- 5 Lock pin boot
- 6 Lock pin sleeve
- 7 Piston
- 8 Piston boot
- 9 Boot ring
- 10 Pad clip
- 11 Support
- 12 Housing
- 13 Shim
- 14 Rubber-coated shim
- 15 Inner pad
- 16 Disc cover
- 17 Outer pad
- 18 Disc rotor
- 19 Piston seal

Tightening torque: N-m (kg-m, ft-lb)

T1:	34 — 44 (3.5 — 4.5, 25 — 33)
T2:	7 — 9 (0.7 — 0.9, 5.1 — 6.5)
T3:	69 — 88 (7 — 9, 51 — 65)
T4:	10 — 18 (1.0 — 1.8, 7 — 13)



2. Rear Disc Brake



Tightening torque: N-m (kg-m, ft-lb)
 T1: 16 - 24 (1.6 - 2.4, 12 - 17)
 T2: 46 - 58 (4.7 - 5.9, 34 - 43)

Fig. 53

B4-1335

4. Master Cylinder

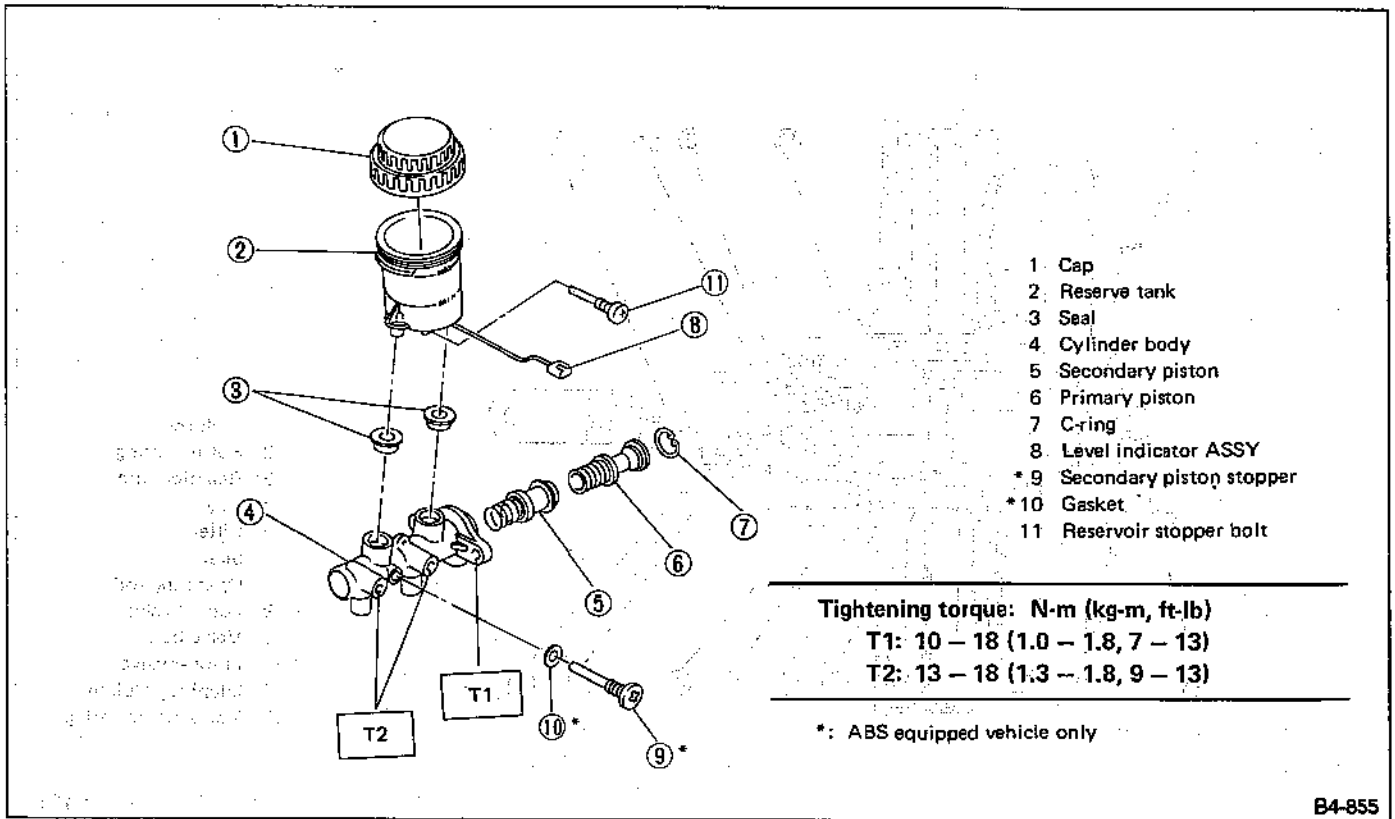


Fig. 55

B4-855

5. Brake Booster

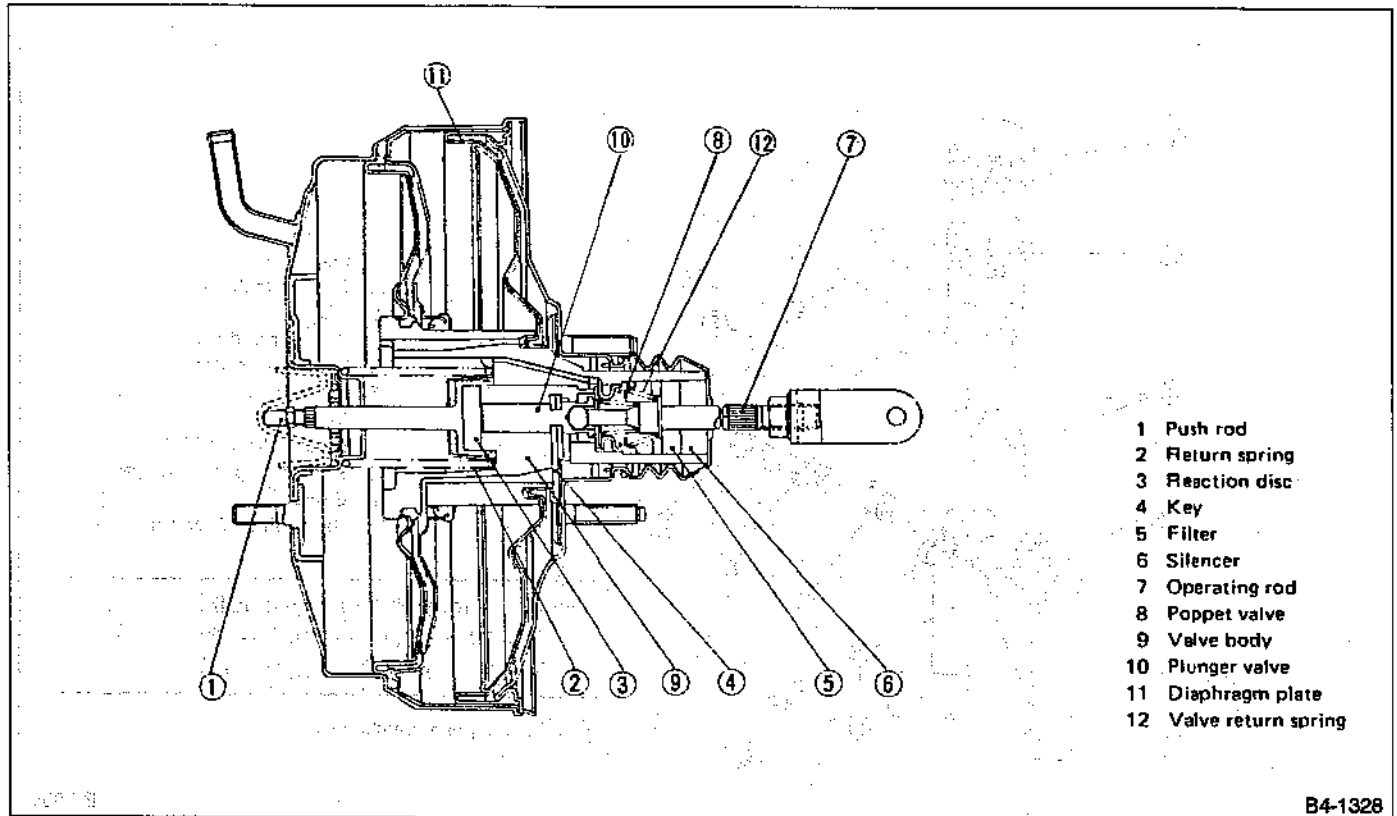
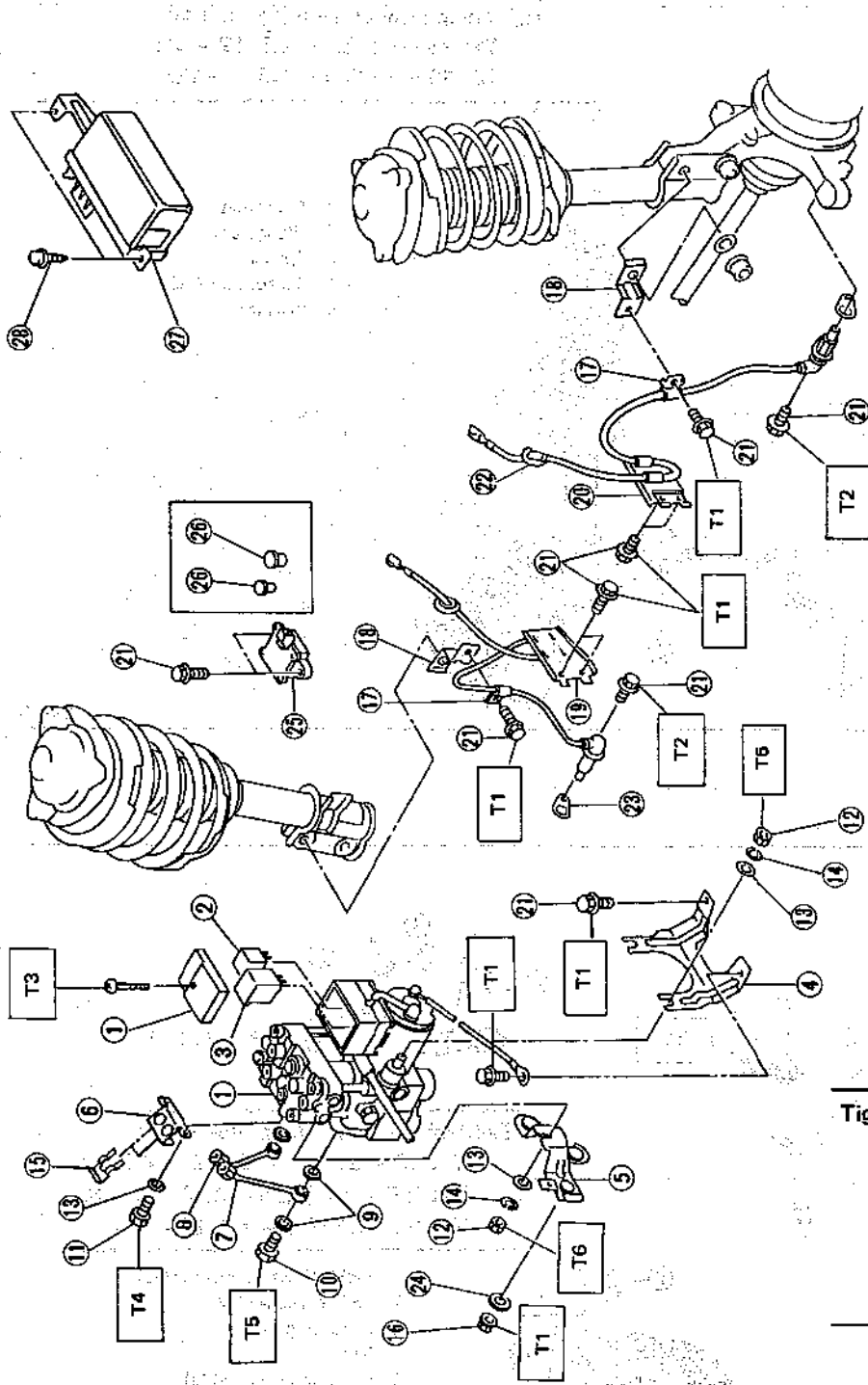


Fig. 56

B4-1328

6. ABS System



- 1 Hydraulic control unit ASSY
- 2 Motor relay
- 3 Valve relay
- 4 Hydraulic control unit bracket (A)
- 5 Hydraulic control unit bracket (B)
- 6 Joint bracket
- 7 Inlet joint RH
- 8 Inlet joint LH
- 9 Gasket
- 10 Union bolt
- 11 Socket bolt
- 12 Nut
- 13 Washer
- 14 Spring washer
- 15 Clamp
- 16 Flange nut
- 17 Front harness clamp
- 18 ABS harness bracket
- 19 Body COMPL bracket RH
- 20 Body COMPL bracket LH
- 21 Flange bolt
- 22 Grogmet
- 23 ABS spacer
- 24 Spacer
- 25 G sensor
- 26 Plug
- 27 Electronic control unit ASSY
- 28 Screw

Tightening torque: N-m (kg-m, ft-lb)

T1:	23 - 42 (2.3 - 4.3, 17 - 31)
T2:	10 - 16 (1.0 - 1.6, 7 - 12)
T3:	1.2 - 1.5 (0.12 - 0.15, 0.9 - 1.1)
T4:	13 - 18 (1.3 - 1.8, 9 - 13)
T5:	15 - 20 (1.5 - 2.0, 11 - 14)
T6:	7 - 9 (0.7 - 0.9, 5.1 - 6.5)

Fig. 57 Front ABS system

B4-1497

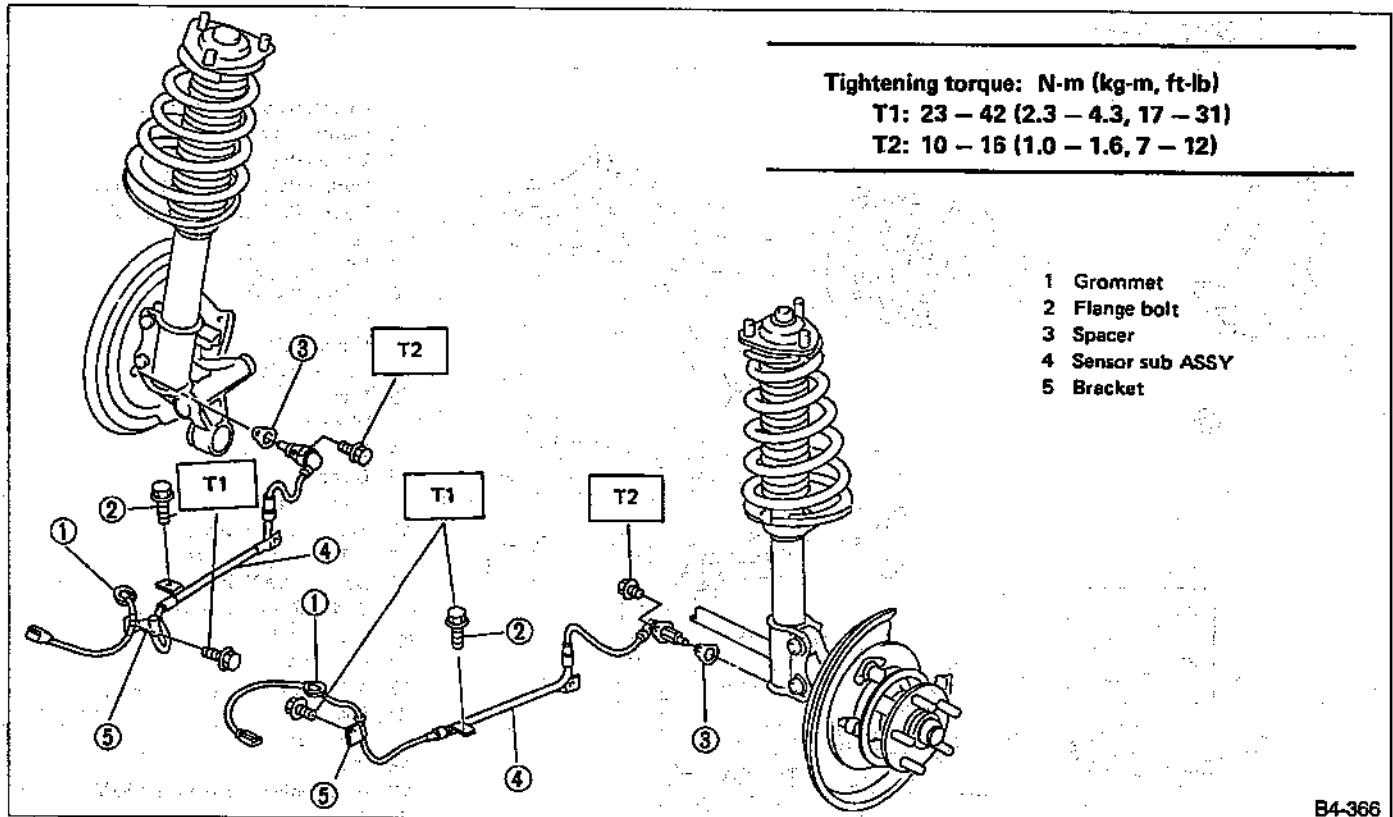


Fig. 58

7. Hill-Holder

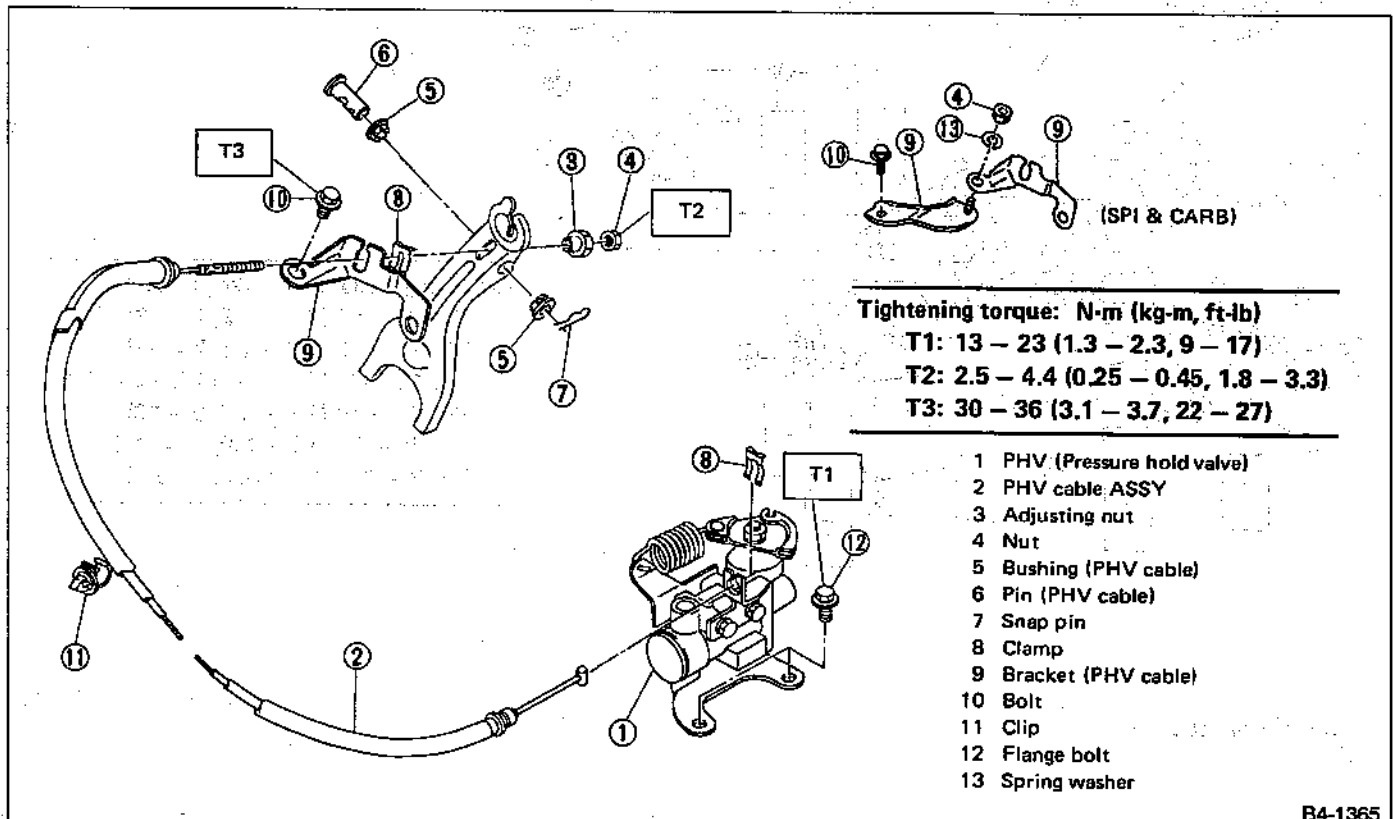
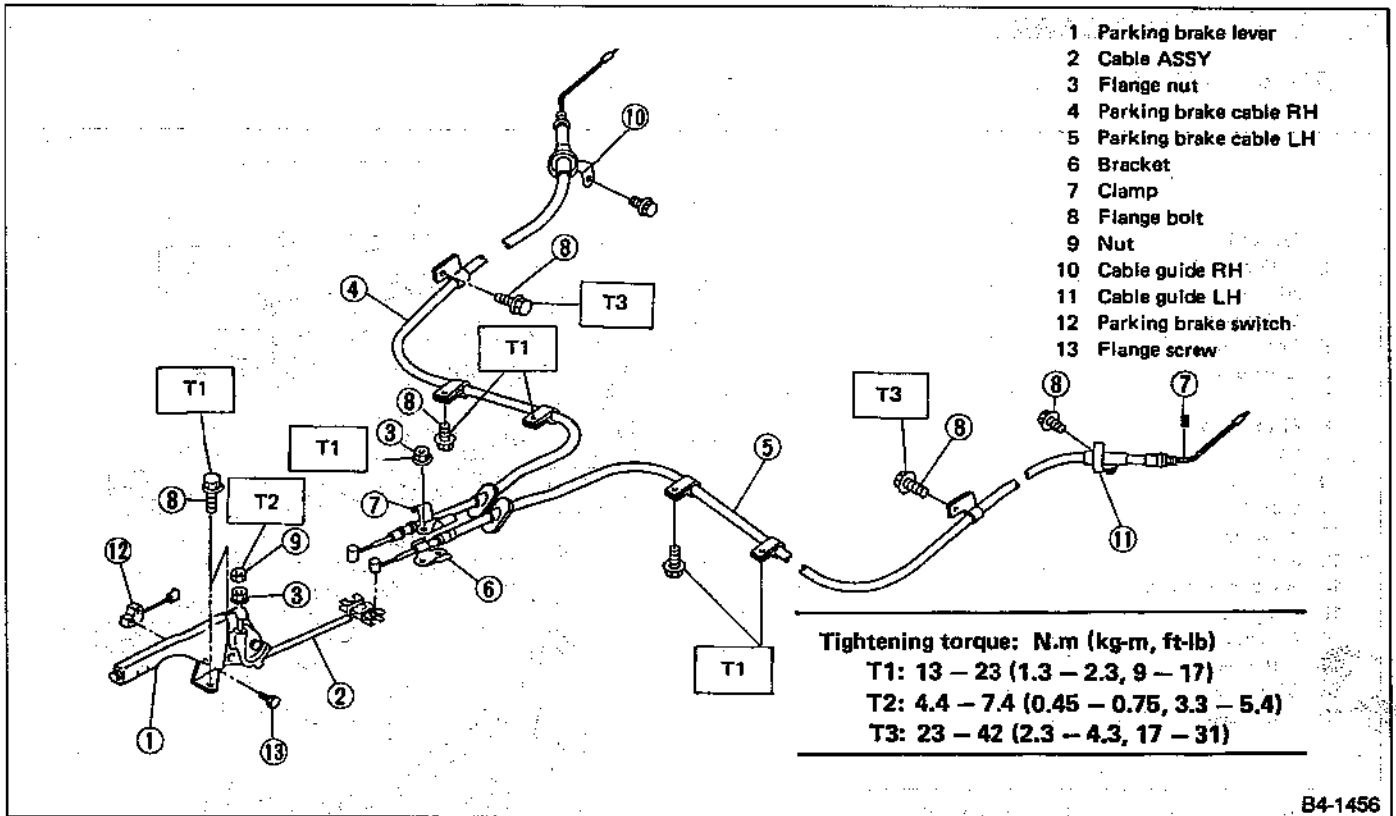


Fig. 59

8. Parking (Hand) Brake



B4-1456

Fig. 60

W SERVICE PROCEDURE

1. Front Disc Brake

1. TURBO MODEL

- 1 Lock pin
- 2 Caliper body
- 3 Air bleeder screw
- 4 Guide pin boot
- 5 Lock pin boot
- 6 Lock pin sleeve
- 7 Piston
- 8 Piston boot
- 9 Boot ring
- 10 Pad clip
- 11 Support
- 12 Housing
- 13 Shim
- 14 Rubber-coated shim
- 15 Inner pad
- 16 Disc cover
- 17 Outer pad
- 18 Disc rotor
- 19 Piston seal

Tightening torque: N·m (kg-m, ft-lb)

T1: 34 — 44 (3.5 — 4.5, 25 — 33)

T2: 7 — 9 (0.7 — 0.9, 5.1 — 6.5)

T3: 69 — 88 (7 — 9, 51 — 65)

T4: 10 — 18 (1.0 — 1.8, 7 — 13)

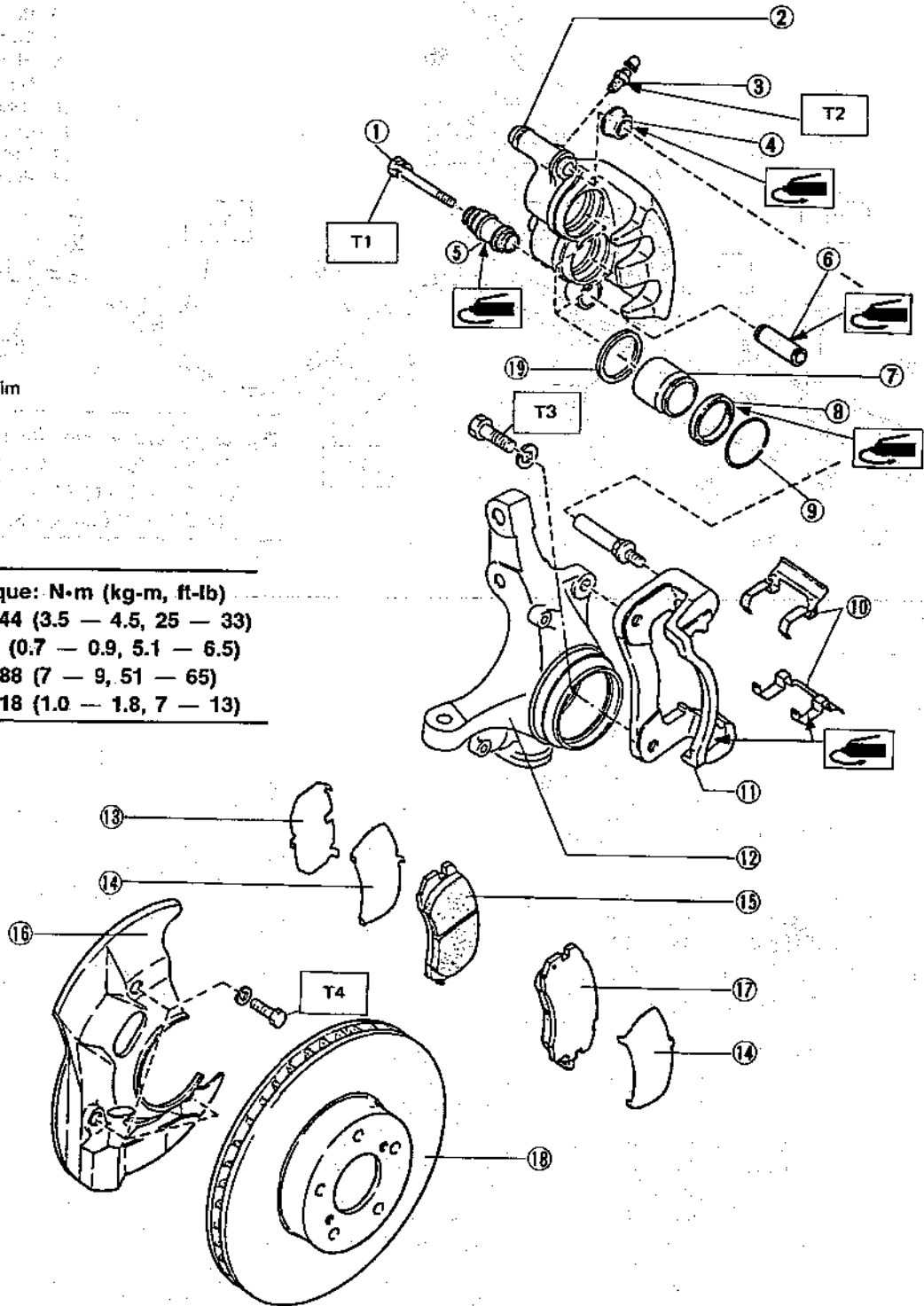
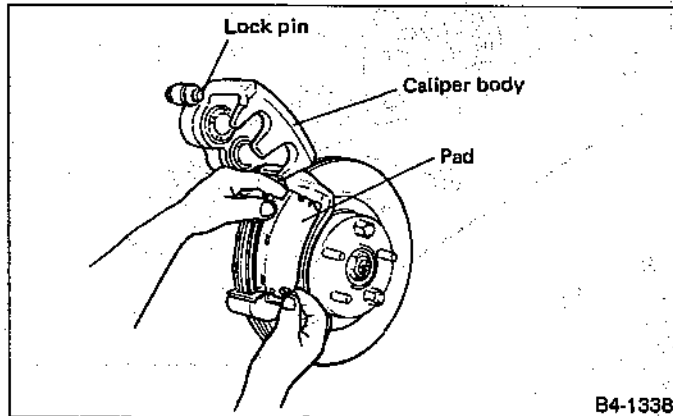


Fig. 61

B4-1337

A: ON-CAR SERVICE**1. PAD**

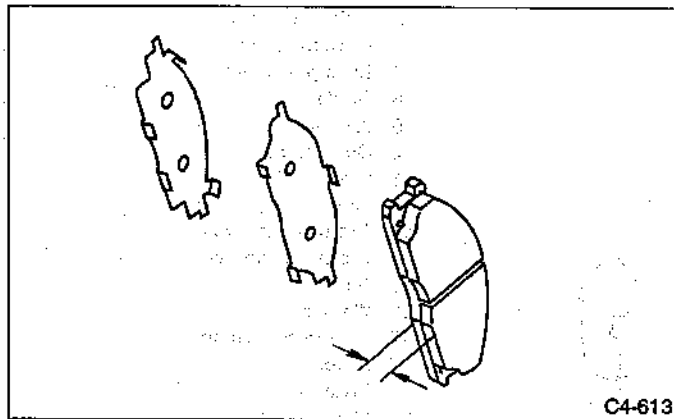
- 1) Remove lock pin.
- 2) Raise caliper body.
- 3) Remove pad.



B4-1338

Fig. 63

- 4) Check pad thickness A.



C4-613

Fig. 64

Pad thickness (including back metal) mm (in)	Standard value	17 (0.67)
	Wear limit	7.5 (0.295)

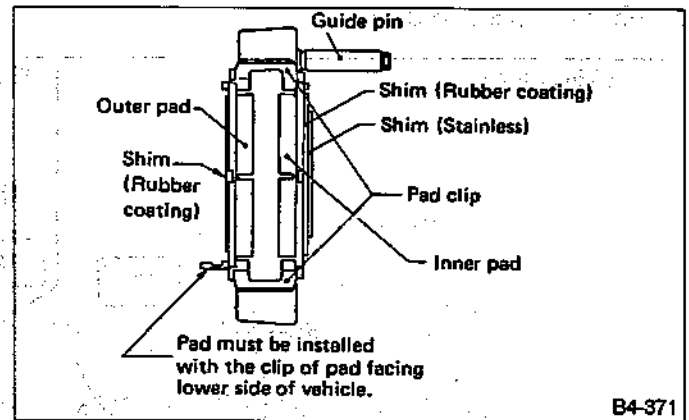
a. Always replace the pads for both the left and right wheels at the same time. Also replace pad clips if they are twisted or worn.

b. A wear indicator is provided on the outer disc brake pad. If the pad wears down to such an extent that the end of the wear indicator contacts the disc rotor, a squeaking sound is produced as the wheel rotates. If this sound is heard, replace the pad.

c. Replace pad if there is oil or grease on it.

5) Apply thin coat of PBC GREASE (725191330 or 003607000) to the frictional portion between pad and pad clip.

6) Install pads on support.



B4-371

Fig. 65

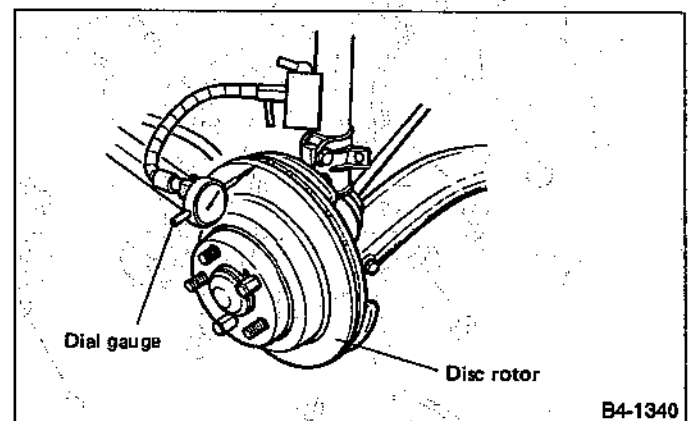
7) Install caliper body on support.

If it is difficult to push piston during pad replacement, loosen air bleeder to facilitate work.

2. DISC ROTOR

1) Set a dial gauge on the disc rotor. Turn disc rotor to check runout.

Make sure that dial gauge is set 5 mm (0.20 in) inward of rotor outer perimeter.



B4-1340

Fig. 66

Disc rotor runout limit:
0.1 mm (0.004 in)

2) Measure disc rotor thickness.

Make sure that micrometer is set 5 mm (0.20 in) inward of rotor outer perimeter.

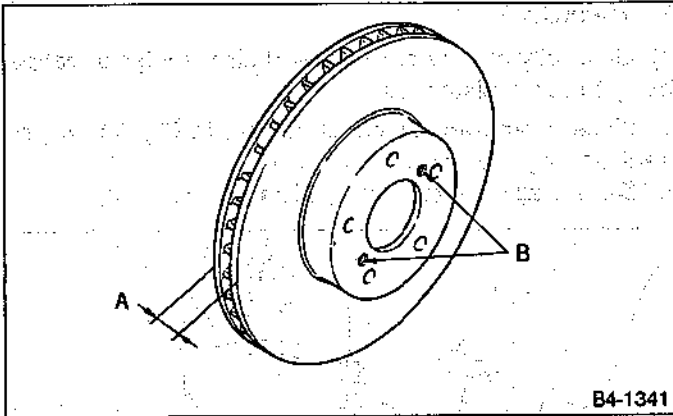


Fig. 67

	Tire dia.	Standard value	Service limit	Disc outside dia.
Disc rotor thickness A mm (in)	13"	18.0 (0.709)	16.0 (0.630)	242 (9.53)
	14"	24.0 (0.945)	22.0 (0.866)	260 (10.24)
	15"	24.0 (0.945)	22.0 (0.866)	277 (10.91)

B: REMOVAL

- 1) Remove union bolt (shown by A in Figure 68), and disconnect brake hose from caliper body ASSY.
- 2) Loosen lock pin (shown by B in Figure 68).

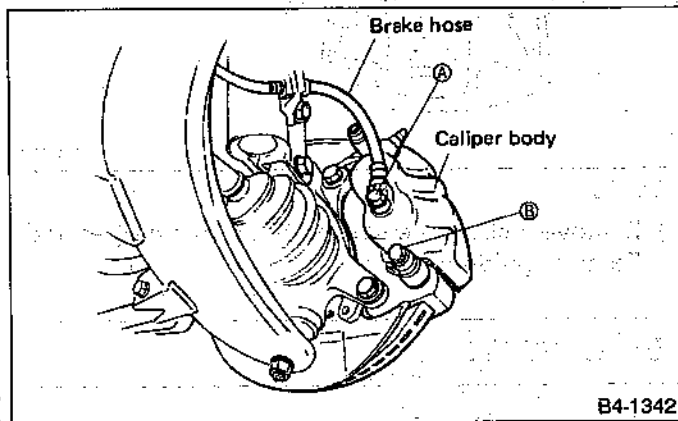


Fig. 68

- 3) Raise caliper body and move it toward vehicle center to separate it from support.

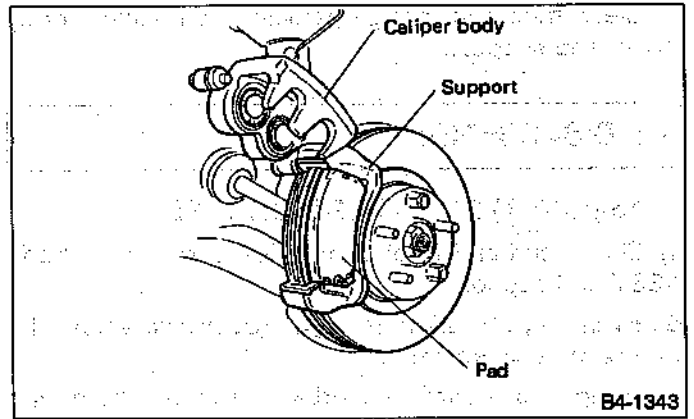


Fig. 69

- 4) Remove support from housing.

Remove support only when replacing it or the rotor. It need not be removed when servicing caliper body ASSY.

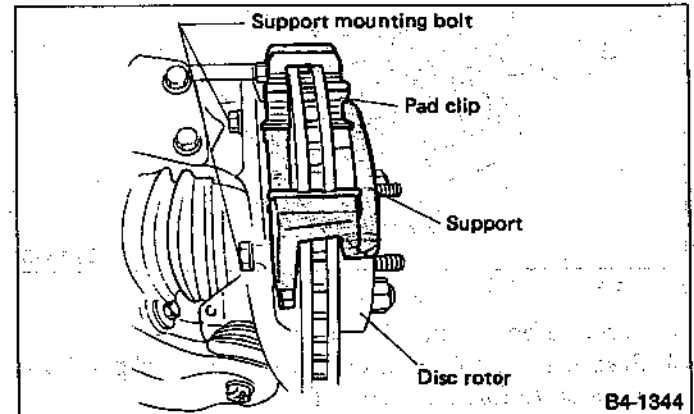


Fig. 70

- 5) Remove disc rotor from hub.

If disc rotor seizes up within hub, drive disc rotor out by installing an 8-mm bolt in holes B on the rotor.

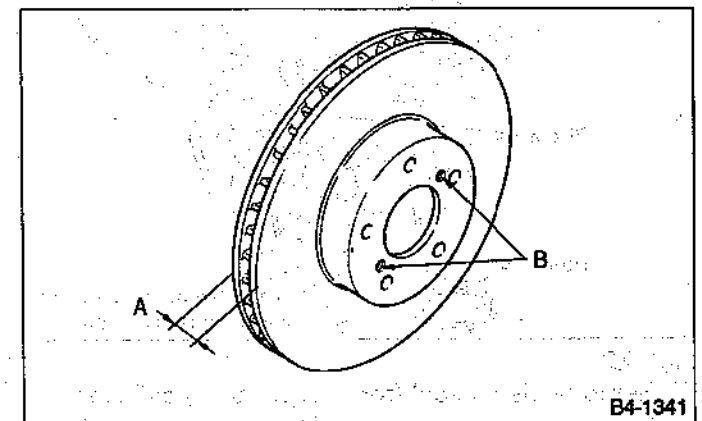


Fig. 71

6) Clean mud and foreign particles from caliper body ASSY and support.

C: DISASSEMBLY

1. 15-INCH TYPE AND 13-INCH TYPE

1) Clean mud and foreign particles from caliper body ASSY and support.

Be careful not to allow foreign particles to enter inlet (at brake hose connector).

2) Using a standard screwdriver, remove boot ring from piston.

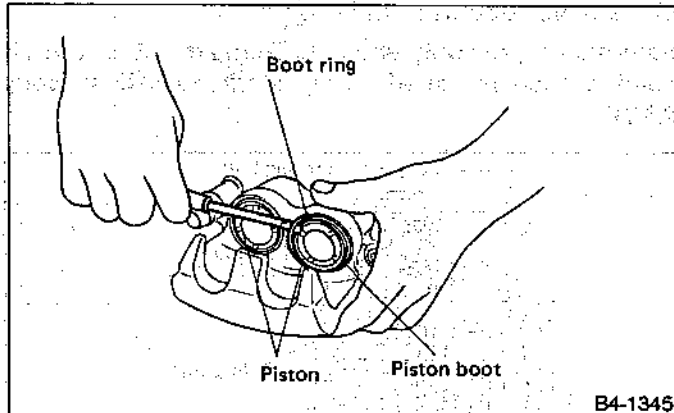


Fig. 72

3) Remove boot from piston end.

4) Gradually supply compressed air via caliper body brake hose to force piston out.

Place a wooden block as shown in Fig. 73 to prevent damage to piston.

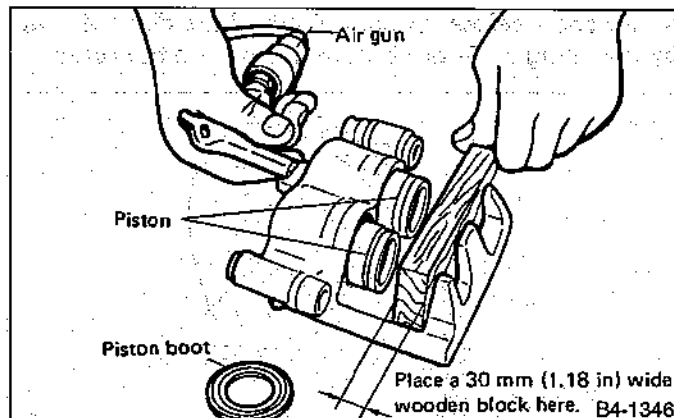


Fig. 73

- 5) Remove piston seal from caliper body cylinder.
- 6) Remove lock pin sleeve and boot from caliper body.
- 7) Remove guide pin boot.

2. 14-INCH TYPE

1) Gradually supply compressed air via inlet of caliper body to force piston out.

a. Place a wooden block as shown in Fig. 74 to prevent damage to piston.

b. Do not apply excessively high pressure.

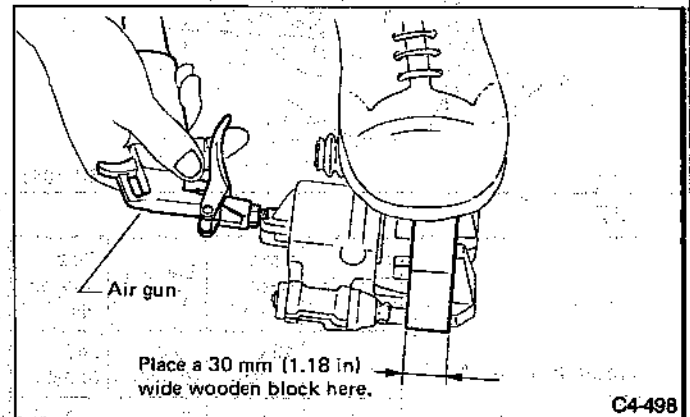


Fig. 74

2) Remove piston boot.

3) Remove piston seal from caliper body cylinder.

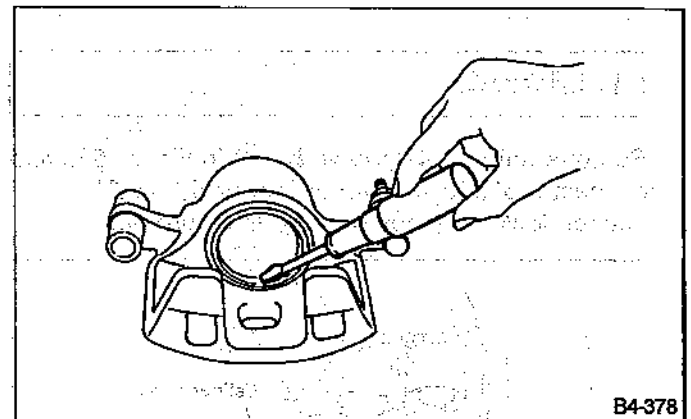


Fig. 75

- 4) Remove lock pin sleeve and boot from caliper body.
- 5) Remove guide pin boot.

D: INSPECTION

- 1) Repair or replace faulty parts.
- 2) Check caliper body and piston for uneven wear, damage or rust.
- 3) Check rubber parts for damage or deterioration.

E: ASSEMBLY

1. 15-INCH TYPE AND 13-INCH TYPE

- 1) Clean caliper body interior using brake fluid.
- 2) Apply a coat of brake fluid to piston seal and fit piston seal in groove on caliper body.
- 3) Apply a coat of brake fluid to the entire inner surface of cylinder and outer surface of piston.
- 4) Insert piston into cylinder.

Do not force piston into cylinder.

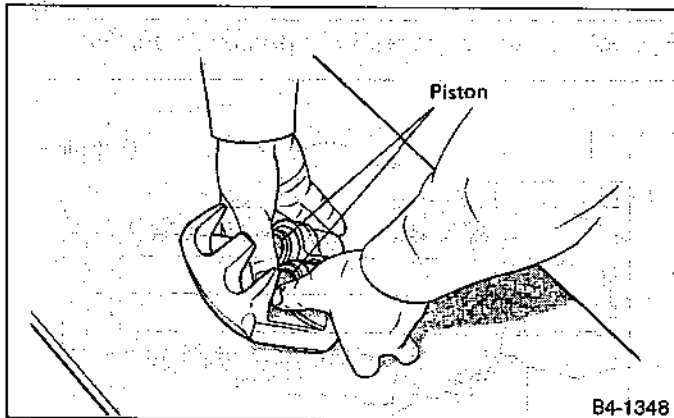


Fig. 76

- 5) Apply a coat of specified grease to boot and fit in groove on ends of cylinder and piston.

Grease:
NIGLUBE RX-2

To facilitate installation, fit boot starting with piston end.

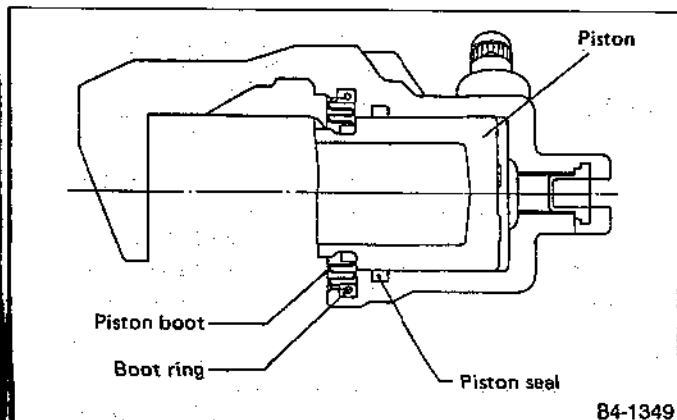


Fig. 77

- 6) Install boot ring. Be careful not scratch boot.
- 7) Apply a coat of specified grease to guide pin, outer surface, sleeve outer surface, cylinder inner surface, and boot grooves.

Grease:
RUBBER GREASE or NIGLUBE RX-2

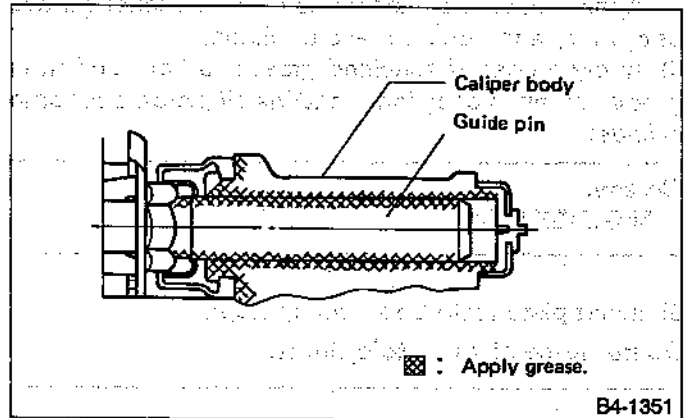


Fig. 78

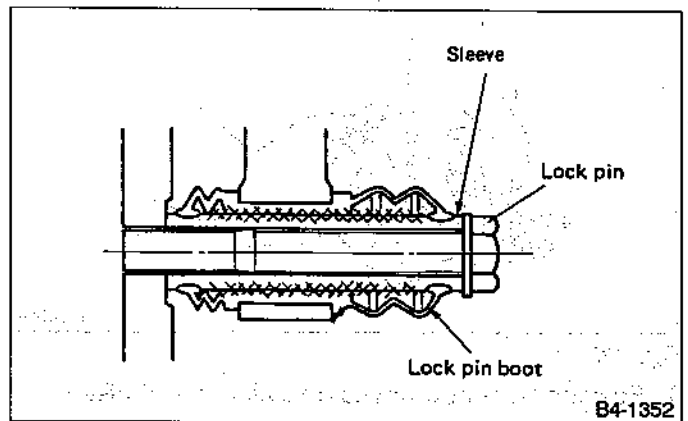


Fig. 79

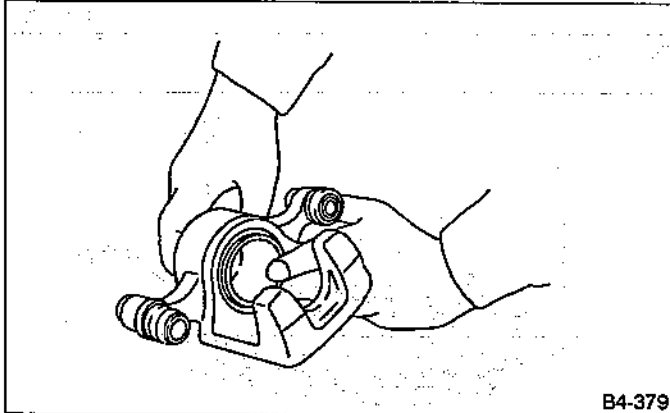
- 8) Install guide pin boots on caliper body.
- 9) Install lock pin boots on caliper body and insert lock pin sleeve into place.

2. 14-INCH TYPE

- 1) Clean caliper body interior using brake fluid.
- 2) Apply a coat of brake fluid to piston seal and fit piston seal in groove on caliper body.
- 3) Apply a coat of brake fluid to the entire inner surface of cylinder and outer surface of piston.
- 4) Apply a coat of specified grease to boot and fit in groove on ends of cylinder and install piston boot onto cylinder.

Grease:
NIGLUBE RX-2

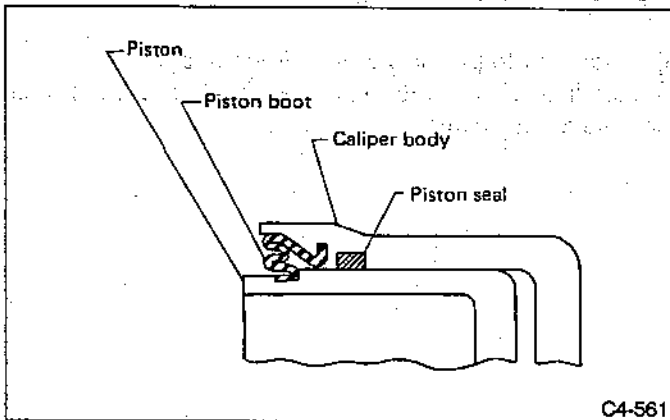
- 5) Insert piston into boot and cylinder.
Do not force piston into cylinder.



B4-379

Fig. 80

- 6) Position boot in grooves on cylinder and piston.

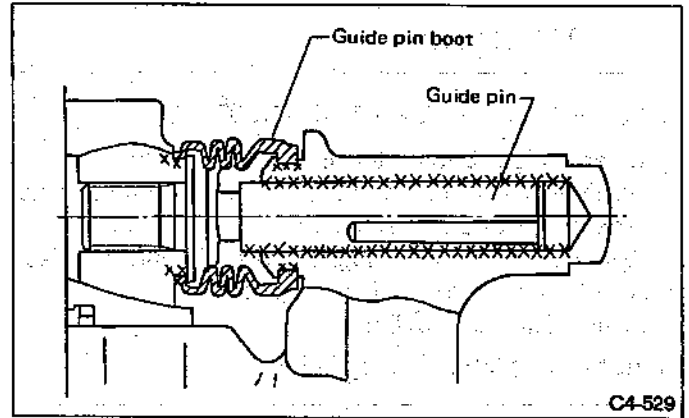


C4-561

Fig. 81

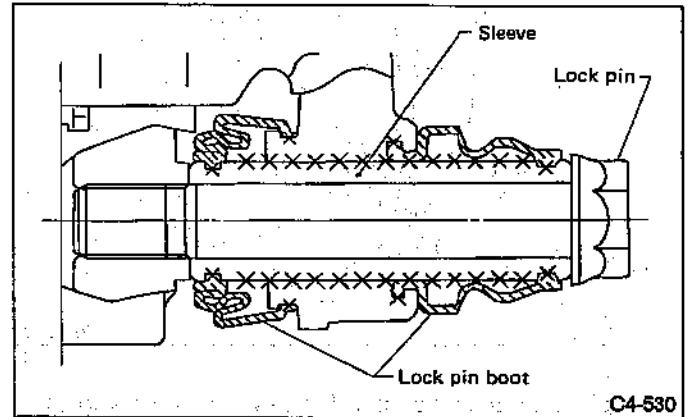
- 7) Apply a coat of specified grease to guide pin outer surface, sleeve outer surface, and boot grooves.

Grease:
RUBBER GREASE or NIGLUBE RX-2



C4-529

Fig. 82 Grease application to guide pin portion



C4-530

Fig. 83 Grease application to lock pin portion

- 8) Install guide pin boot on caliper body.
- 9) Install lock pin boot on caliper body and insert lock pin sleeve into place.

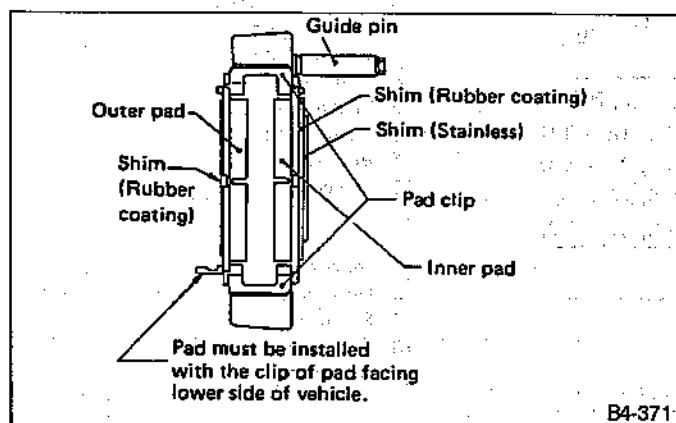
F: INSTALLATION

- 1) Install disc rotor on housing.
- 2) Install support on housing.

Tightening torque:

69 — 88 N·m (7 — 9 kg-m, 51 — 65 ft-lb)

- a. Always replace the pads for both the left and right wheels at the same time. Also replace pad clips if they are twisted or worn.
 - b. A wear indicator is provided on the outer disc brake pad. If the pad wears down to such an extent that the end of the wear indicator contacts the disc rotor, a squeaking sound is produced as the wheel rotates. If this sound is heard, replace the pad.
 - c. When replacing the pad, replace pads of the right and left wheels at the same time.
- 3) Apply thin coat of PBC GREASE (725191330 or 003607000) to the frictional portion between pad and pad clip.
 - 4) Install pads, rubber coated shim and stainless shim on support.



B4-371

Fig. 84

- 5) Install caliper body on support.

Tightening torque:

34 — 44 N·m (3.5 — 4.5 kg-m, 25 — 33 ft-lb)

- 6) Connect brake hose.

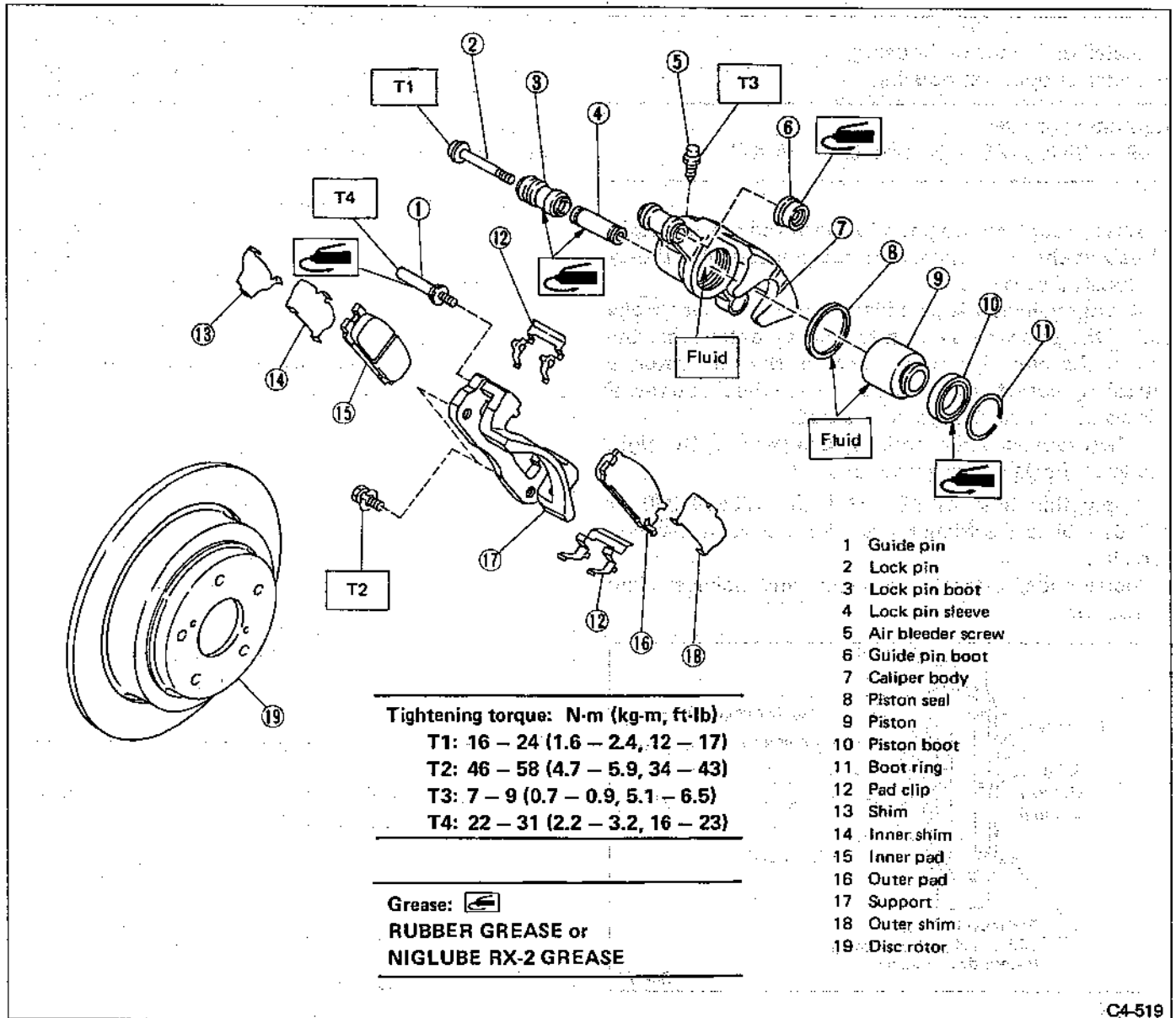
Tightening torque:

15 — 21 N·m (1.5 — 2.1 kg-m, 11 — 15 ft-lb)

Replace brake hose gaskets with new ones.

- 7) Bleed air from brake system.

2. Rear Disc Brake



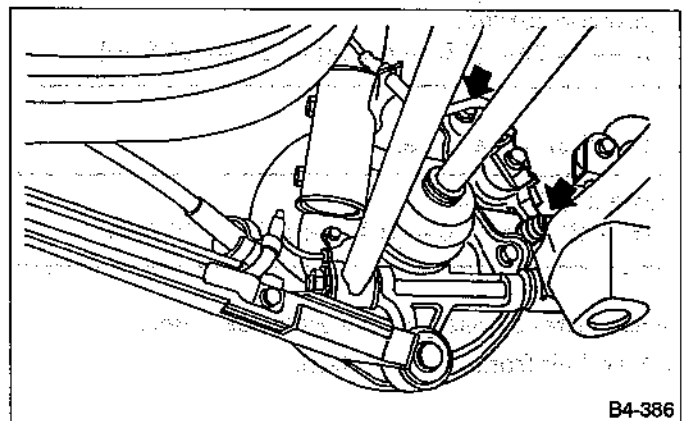
C4-519

Fig. 85

A: ON-CAR SERVICE

1. PAD

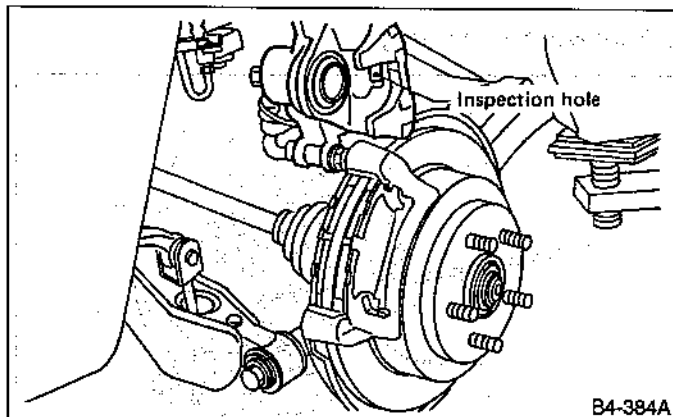
- 1) Remove lock pin.



B4-386

Fig. 86

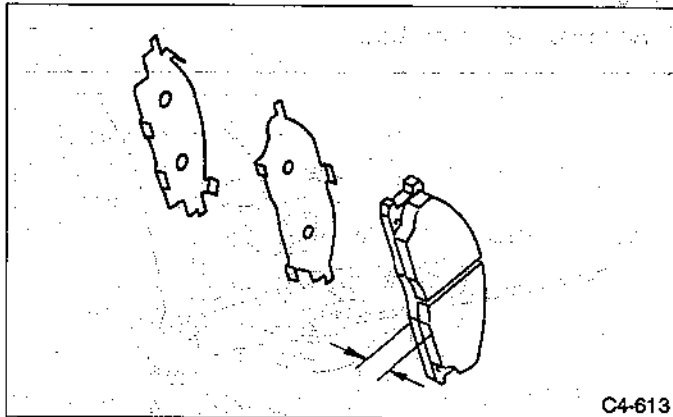
- 2) Raise caliper body.
- 3) Remove pad from support.



B4-384A

Fig. 87

- 4) Check pad thickness A.

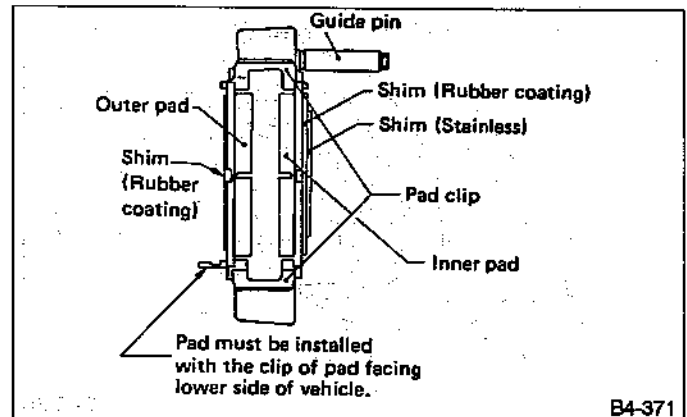


C4-613

Fig. 88

Pad thickness (including back metal) mm (in)	Standard value	15.0 (0.591)
	Wear limit	6.5 (0.256)

- a. Always replace the pads for both the left and right wheels at the same time. Also replace pad clips if they are twisted or worn.
 - b. A wear indicator is provided on the outer disc brake pad. If the pad wears down to such an extent that the end of the wear indicator contacts the disc rotor, a squeaking sound is produced as the wheel rotates. If this sound is heard, replace the pad.
 - c. Replace pad if there is oil or grease on it.
- 5) Apply thin coat of PBC GREASE (725191330 or 03607000) to the frictional portion between pad and pad clip.
 - 6) Install pad on support.



B4-371

Fig. 89

- 7) Install caliper body on support.

Tightening torque:

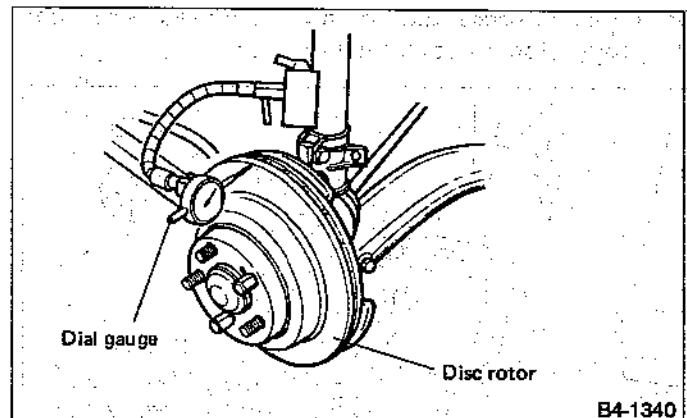
16 — 24 N·m (1.6 — 2.4 kg-m, 12 — 17 ft-lb)

If it is difficult to push piston during pad replacement, loosen air bleeder to facilitate work.

2. DISC ROTOR

- 1) Set a dial gauge on the disc rotor. Turn disc rotor to check runout.

Make sure that dial gauge is set 5 mm (0.20 in) inward of rotor outer perimeter.



B4-1340

Fig. 90

Disc rotor runout limit:

0.1 mm (0.004 in)

- 2) Measure disc rotor thickness.

Make sure that micrometer is set 5 mm (0.20 in) inward of rotor outer perimeter.

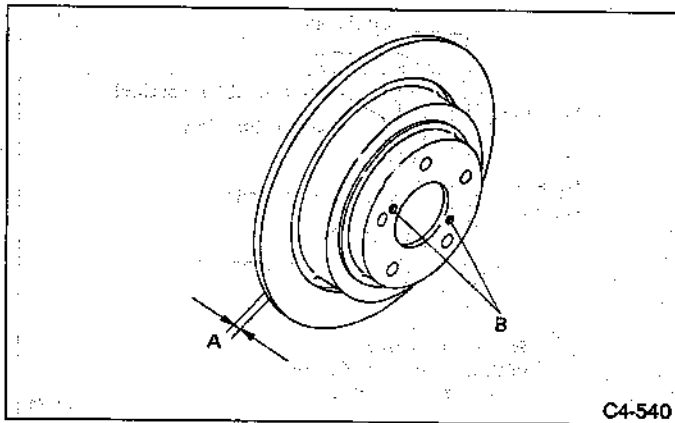


Fig. 91

Disc rotor thickness A mm (in)	Disc type	Standard value	Service limit
	Solid type	10 (0.39)	8.5 (0.335)
	Ventilated type	18 (0.71)	16 (0.63)

When removing disc rotor, refer to instructions under Parking Brake [W3A0].

B: REMOVAL

- 1) Lift up vehicle and remove wheels.
- 2) Disconnect brake hose from caliper body ASSY.

Do not allow brake fluid to come in contact with vehicle body; wipe off completely if spilled.

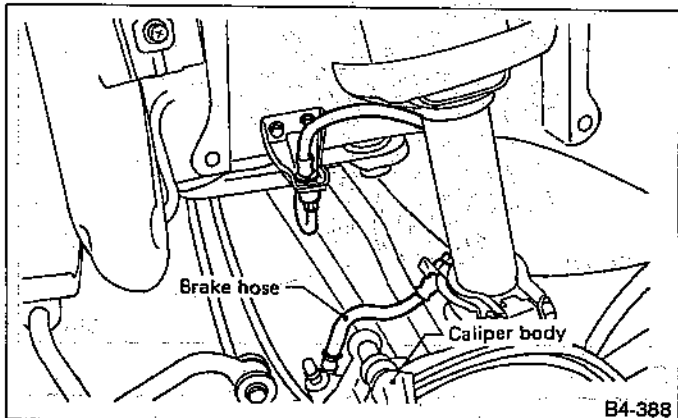


Fig. 92

- 3) Remove lock pin.
- 4) Raise caliper body and move it toward vehicle center to separate it from support.
- 5) Remove support from back plate.

Remove support only when replacing it or the rotor. It need not be removed when servicing caliper body ASSY.

- 6) Clean mud and foreign particles from caliper body ASSY and support.

Be careful not to allow foreign particles to enter inlet (at brake hose connector).

C: DISASSEMBLY

- 1) Remove the boot ring.

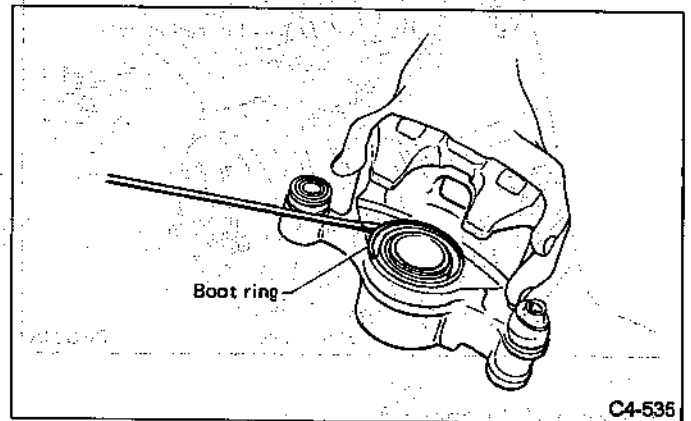


Fig. 93

- 2) Remove the piston boot.

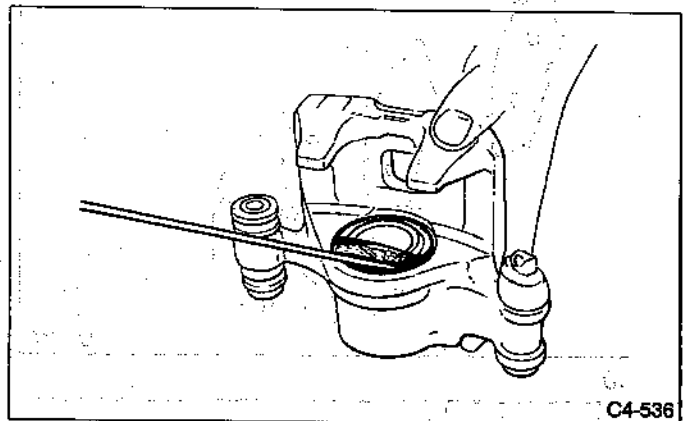


Fig. 94

- 3) Gradually supply compressed air via inlet of caliper body to force piston out.

- a. Place a wooden block as shown in Fig. 95 to prevent damage to piston.
- b. Do not apply excessively high pressure.

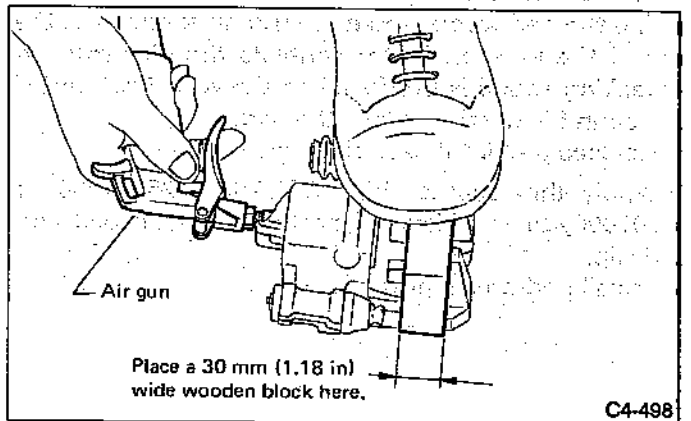
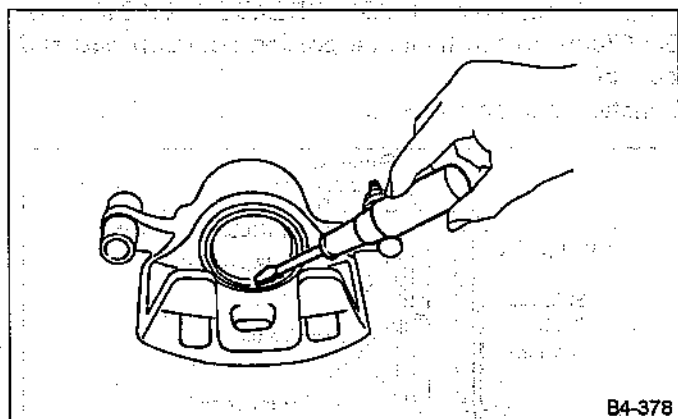


Fig. 95

- 4) Remove piston seal from caliper body cylinder.



B4-378

Fig. 96

- 5) Remove lock pin sleeve and boot from caliper body.
6) Remove guide pin boot.

D: INSPECTION

- 1) Repair or replace faulty parts.
- 2) Check caliper body and piston for uneven wear, damage or rust.
- 3) Check rubber parts for damage or deterioration.

E: ASSEMBLY

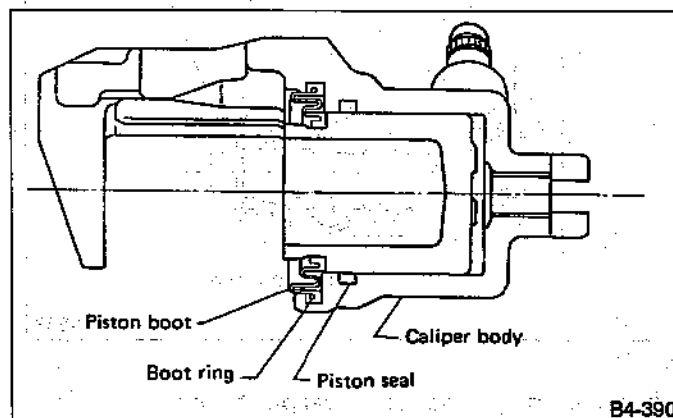
- 1) Clean caliper body interior using brake fluid.
- 2) Apply a coat of brake fluid to piston seal and fit piston seal in groove on caliper body.
- 3) Apply a coat of brake fluid to the entire inner surface of cylinder and outer surface of piston.
- 4) Insert piston into cylinder.

Do not force piston into cylinder.

- 5) Apply a coat of specified grease to boot and fit in groove on ends of cylinder and piston.

Grease:
NIGLUBE RX-2

- 6) Install the piston boot to the caliper body, and attach boot ring.

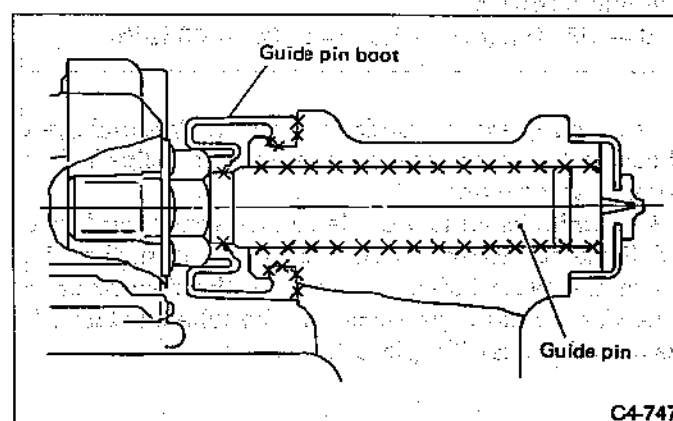


B4-390

Fig. 97

- 7) Apply a coat of specified grease to guide pin, outer surface, sleeve outer surface, cylinder inner surface, and boot grooves.

Grease:
RUBBER GREASE or NIGLUBE RX-2



C4-747

Fig. 98

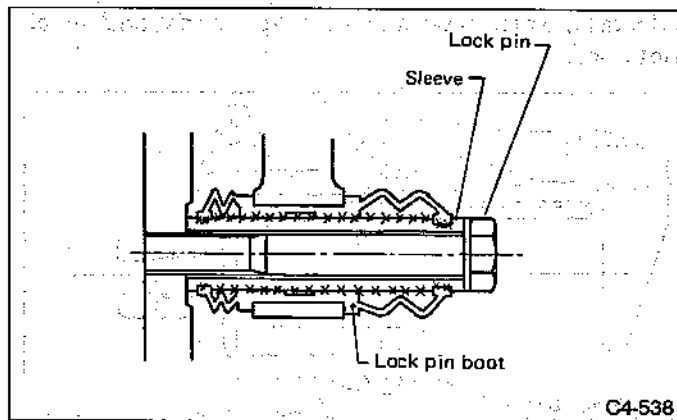


Fig. 99

- 8) Install guide pin boots on caliper body.
- 9) Install lock pin boots on caliper body and insert lock pin sleeve into place.

F: INSTALLATION

- 1) Install disc rotor on hub.
- 2) Install support on back plate.

Tightening torque:

46 — 58 N·m (4.7 — 5.9 kg-m, 34 — 43 ft-lb)

- a. Always replace the pads for both the left and right wheels at the same time. Also replace pad clips if they are twisted or worn.
- b. A wear indicator is provided on the outer disc brake pad. If the pad wears down to such an extent that the end of the wear indicator contacts the disc rotor, a squeaking sound is produced as the wheel rotates. If this sound is heard, replace the pad.

- c. Replace pads if there is oil or grease on them.
- 3) Apply thin coat of PBC GREASE (725191330 or 003607000) to the frictional portion between pad and pad clip.
- 4) Install pads on support.

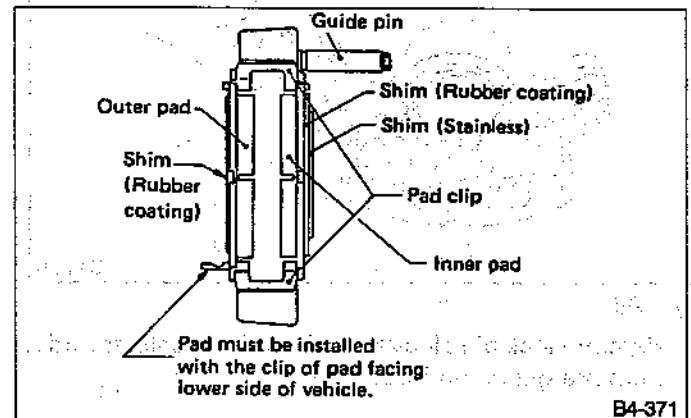


Fig. 100

- 5) Install caliper body on support.

Tightening torque:

16 — 24 N·m (1.6 — 2.4 kg-m, 12 — 17 ft-lb)

- 6) Connect brake hose.

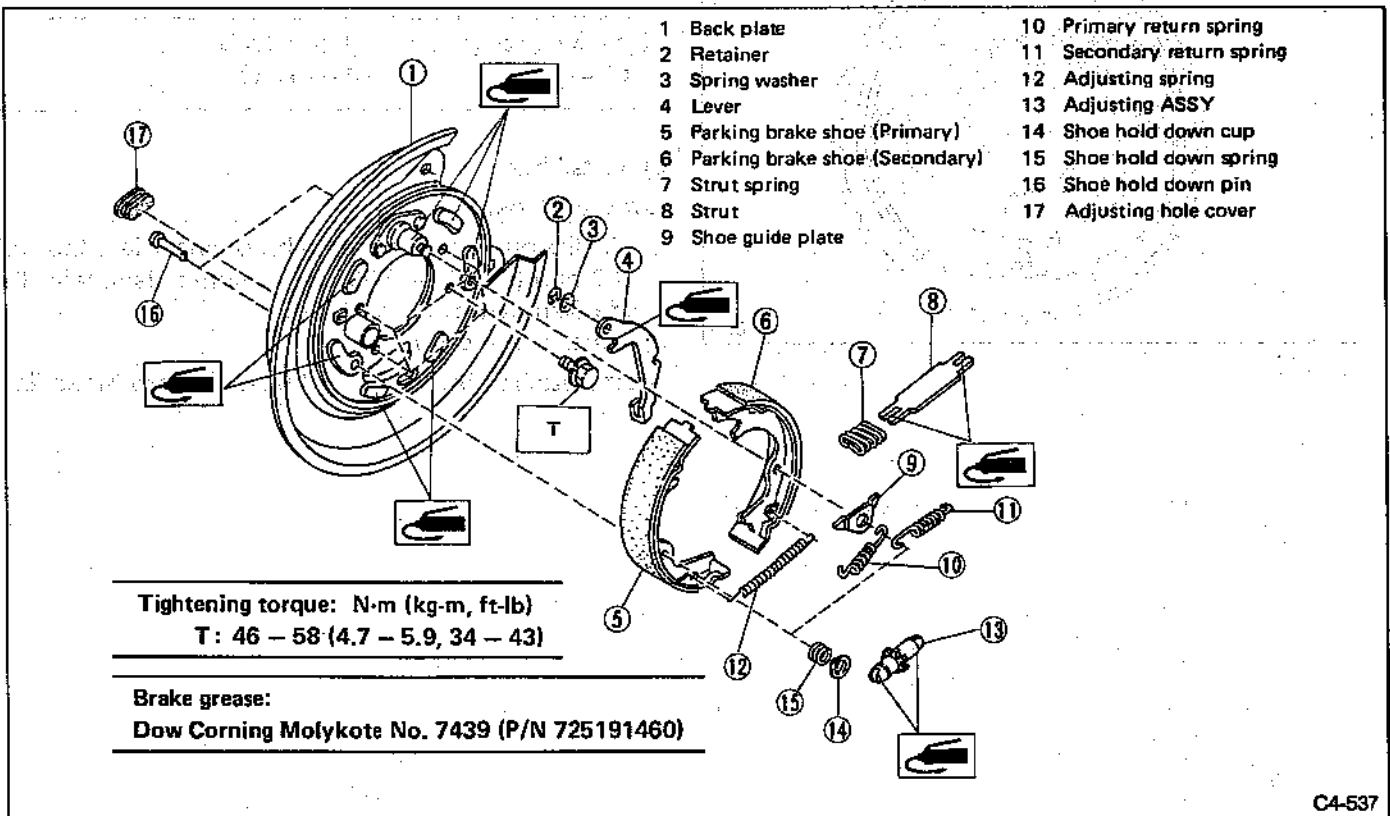
Tightening torque:

16 — 20 N·m (1.6 — 2.0 kg-m, 12 — 14 ft-lb)

- a. The brake hose must be connected without any twist.
- b. Replace brake hose gaskets with new ones.
- 7) Bleed air from brake system.

4. Parking Brake (Rear Disc Brake)

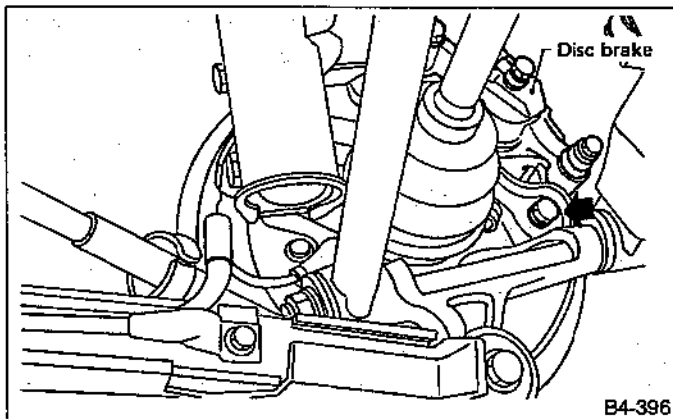
A: REMOVAL



C4-537

Fig. 118

1) Remove the two mounting bolts and remove the disc brake ASSY.



B4-396

Fig. 119

2) Suspend the disc brake ASSY so that the hose is not stretched.

3) Remove the disc rotor.

4) Remove shoe return spring from parking brake ASSY.

5) Remove front shoe hold down spring and pin with pliers.

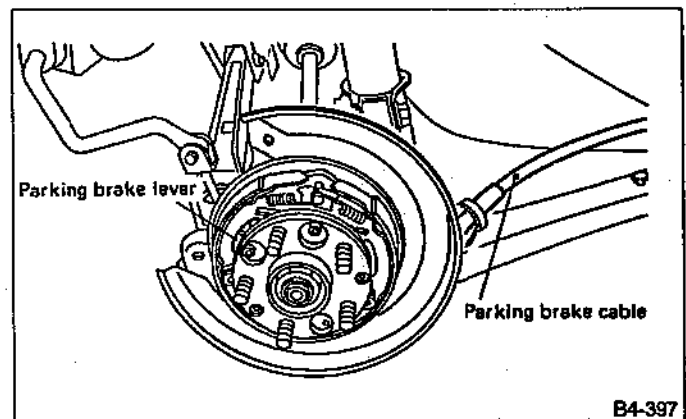
6) Remove strut and strut spring.

7) Remove adjuster ASSY from parking brake ASSY.

8) Remove brake shoe.

9) Remove rear shoe hold-down spring and pin with pliers.

10) Remove parking cable from parking lever.



B4-397

Fig. 120

11) Using a standard screwdriver, raise retainer. Remove parking lever and washer from brake shoe.

B: INSPECTION

1) Measure brake disc inside diameter. If the disc is scored or worn, replace the brake disc.

Disc inside diameter:

Standard

170 mm (6.69 in)

Service limit

171 mm (6.73 in)

2) Measure the lining thickness. If it exceeds the limit, replace shoe ASSY.

Lining thickness:

Standard

3.2 mm (0.126 in)

Service limit

1.5 mm (0.059 in)

Replace the brake shoes on the right and left brake ASSY at the same time.

C: INSTALLATION

Be sure lining surface is free from oil contamination.

Brake grease:

Dow Corning Molykote No 7439 (P/N 725191460)

1) Apply brake grease to the following places. (Refer to Figure 118.)

- (1) Six contact surfaces of shoe rim and back plate packing.
- (2) Contact surface of shoe wave and anchor pin
- (3) Contact surface of lever and strut
- (4) Contact surface of shoe wave and adjuster assembly
- (5) Contact surface of shoe wave and strut
- (6) Contact surface of lever and shoe wave

2) Installation is in reverse order of removal.

a. Use new retainers and clinch them when installing brake shoes to levers.

b. Ensure that parking lever moves smoothly.

c. Do not confuse left parking lever with right one.

d. Do not confuse left strut with right one.

e. Ensure that adjuster assembly is securely installed with screw in the left side, facing vehicle front.

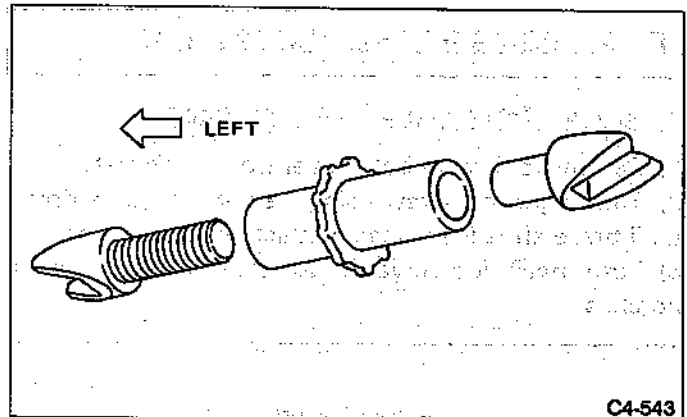


Fig. 121

f. Ensure that shoe return spring is installed as shown in Fig. 122.

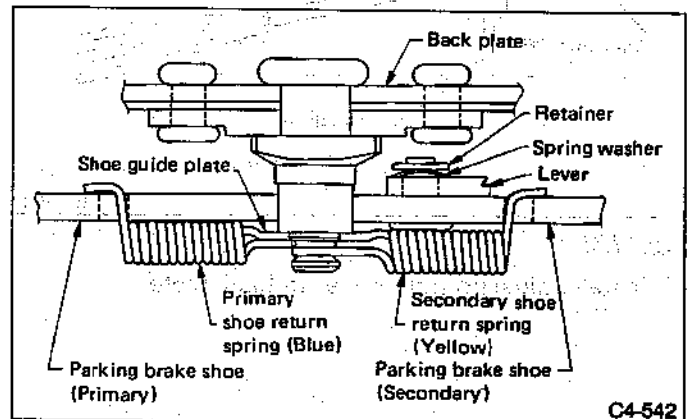


Fig. 122

3) Adjust parking brakes. Refer to 4-4 [W3D1].

a. After replacing parking brake lining, be sure to drive vehicle for "break-in" purposes.

b. Drive the vehicle about 35 km/h (22 MPH).

c. With the parking brake release button pushed in, pull the parking brake lever gently.

d. Drive the vehicle for about 200 meter (0.12 mile) in this condition.

e. Wait 5 to 10 minutes for the parking brake to cool down. Repeat this procedure once more.

f. After breaking-in, re-adjust parking brakes.

D: PARKING BRAKE ADJUSTMENT**1. SHOE CLEARANCE ADJUSTMENT**

- 1) Remove adjusting hole cover from back plate.
- 2) Turn adjusting screw using a slot-type screw driver until brake shoe is in close contact with disc rotor.
- 3) Turn back (downward) adjusting screw 3 or 4 notches.

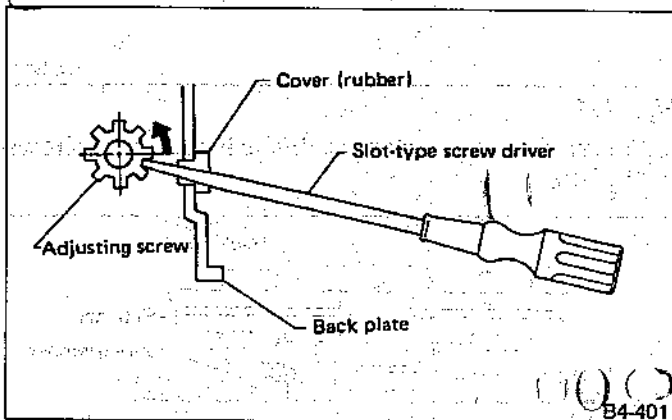


Fig. 123

- 4) Install adjusting hole cover to back plate.

2. LEVER STROKE ADJUSTMENT

- 1) Remove console box lid.
- 2) Forcibly pull parking brake lever 3 to 5 times.
- 3) Adjust parking brake lever by turning adjuster until parking brake lever stroke is set at 6 notches with operating force of 196 N (20 kg, 44 lb).
- 4) Tighten lock nut.

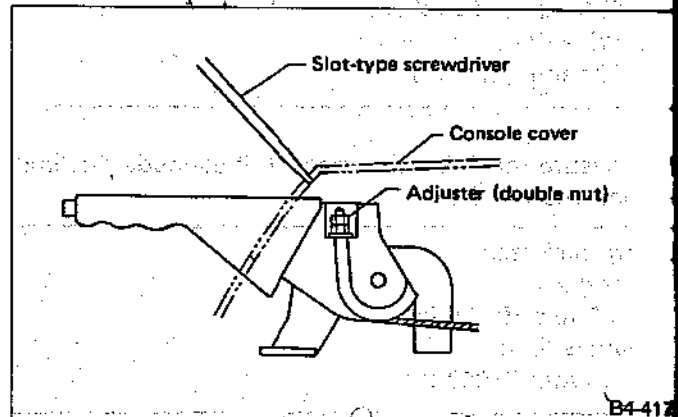


Fig. 124

- 5) Install console box lid.

Lever stroke:

**7 to 8 notches when pulled
with a force of 196 N (20 kg, 44 lb)**

Torque (Adjuster lock nut):

4.4 — 7.4 N·m (0.45 — 0.75 kg·m, 3.3 — 5.4 ft·lb)

5. Master Cylinder

A: REMOVAL

- 1) Thoroughly drain brake fluid from reservoir tank.
- 2) Disconnect fluid level indicator harness connector.
- 3) Remove brake pipes from master cylinder.
- 4) Remove master cylinder mounting nuts, and take out master cylinder from brake booster.

Be extremely careful not to spill brake fluid. Brake fluid spilt on the vehicle body will harm the painted surface; wipe it off quickly if spilt.

B: DISASSEMBLY

1. PRECAUTIONS FOR DISASSEMBLY

- 1) Remove mud and dirt from the surface of brake master cylinder.
- 2) Prepare tools necessary for disassembly operation, and arrange them neatly on work bench.
- 3) Clean work bench.
- 4) Tools for disassembly operation:
 - Phillips screwdriver 1
 - C-ring pliers 1

2. DISASSEMBLY PROCEDURE

- 1) Remove secondary piston stopper. (only vehicle equipped with ABS)
- 2) Remove C-ring with C-ring pliers pushing in primary piston slightly.

Piston may jump out from master cylinder.

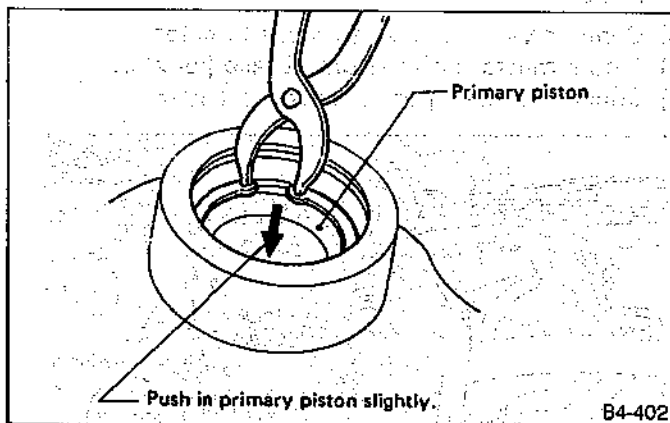


Fig. 125

- 3) Extract primary piston CP and secondary piston CP.
 - a. Do not disassemble the piston CP; otherwise, the spring set value may be changed.
 - b. Use brake fluid or methanol to wash inside wall of cylinder, pistons and piston cups. Be careful not to damage parts when washing. If methanol is used for washing, do not dip rubber parts, such as piston cups, in it for more than 30 seconds; otherwise, they may become swelled.

C: INSPECTION

If any damage, deformation, wear, swelling, rust, and other faults are found on the primary piston CP, secondary piston CP, secondary piston stopper, or gasket, replace the faulty part.

- a. The primary and secondary pistons must be replaced as complete assemblies.
- b. The service limit of the clearance between each piston and the master cylinder inner dia. is 0.11 mm (0.0043 in).
- c. When handling parts, be extremely careful not to damage or scratch the parts, or let any foreign matter get on them.

D: ASSEMBLY

1. PRECAUTIONS FOR ASSEMBLING

- 1) When assembling, be sure to use recommended brake fluid.
- 2) Ensure that the inside wall of cylinder, pistons, and piston cups are free from dirt when assembling.
- 3) Be extremely careful not to damage, scratch, or dent cylinder inside wall, pistons, and piston cups.
- 4) Do not drop parts. Never attempt to use any part that has been dropped accidentally.

2. ASSEMBLING OPERATION

- 1) Assembling piston CP:

Apply recommended brake fluid to inside wall of cylinder, and to outer surface of piston CP, and install piston CPs carefully into cylinder.
- 2) Assembling secondary piston stopper:

After installing piston into cylinder, push primary piston in about 10 mm (0.39 in), using a rod, such as push rod then assemble gasket and secondary piston stopper.

Tightening torque:

1.5 — 2.9 N·m (0.15 — 0.3 kg·m, 1.1 — 2.2 ft·lb)

If the gasket and secondary piston stopper are assembled without pushing in the primary piston, scratches may be caused on the secondary piston, and no pressure may be built up in the secondary side. To avoid such an error, be sure to push in the primary piston before assembling these parts.

- 3) Assembling C-ring:

With primary piston pushed in slightly, attach C-ring by using C-ring pliers.

After assembling, ensure that the C-ring is fitted securely in the ring groove.

E: INSTALLATION

To install the master cylinder to the body, reverse the sequence of removal procedure.

Tightening torque:

Master cylinder mounting nut

10 — 18 N·m (1.0 — 1.8 kg-m, 7 — 13 ft-lb)

Piping flare nut

13 — 18 N·m (1.3 — 1.8 kg-m, 9 — 13 ft-lb)

Be sure to use recommended brake fluid.

6. Brake Booster**A: REMOVAL**

- 1) Remove the following parts at engine compartment.
 - (1) Disconnect connector for brake fluid level indicator.
 - (2) Remove brake pipes from master cylinder.
 - (3) Remove master cylinder installing nuts.
 - (4) Disconnect vacuum hose from brake booster.
- 2) Remove the following parts from the pedal bracket.
 - (1) Snap pin and clevis pin.
 - (2) Four brake booster installing nuts.
- 3) Remove brake booster while shunning brake pipes.

B: INSTALLATION

- 1) Mount brake booster in position.
- 2) Connect operating rod to brake pedal with clevis pin and snap pin.

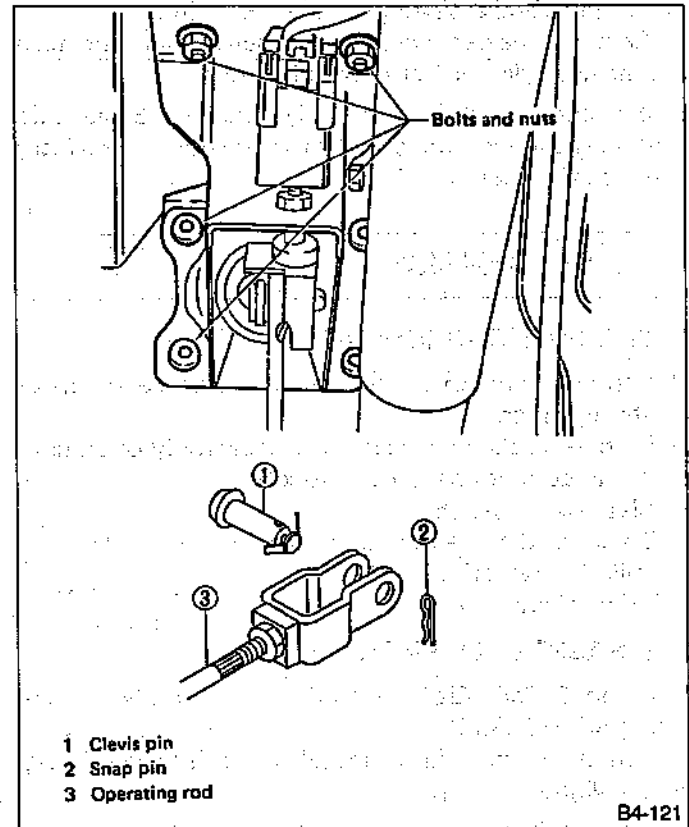


Fig. 126

- 3) Connect vacuum hose to brake booster.
- 4) Mount master cylinder onto brake booster.
- 5) Connect brake pipes to master cylinder.

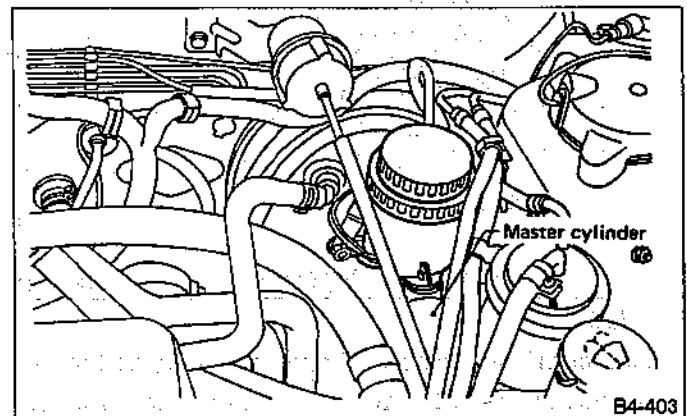


Fig. 127

- 6) Connect electric connector for brake fluid level indicator.
- 7) Adjust operating rod of brake booster as follows:
- (1) Be sure engine is off. (No vacuum is applied to brake booster.)
 - (2) There should be play between brake booster clevis and pin at brake pedal installing portion.
(Depress brake pedal with a force of less than 10 N [1 kg, 2 lb] to a stroke of 1 to 3 mm [0.04 to 0.12 in].)

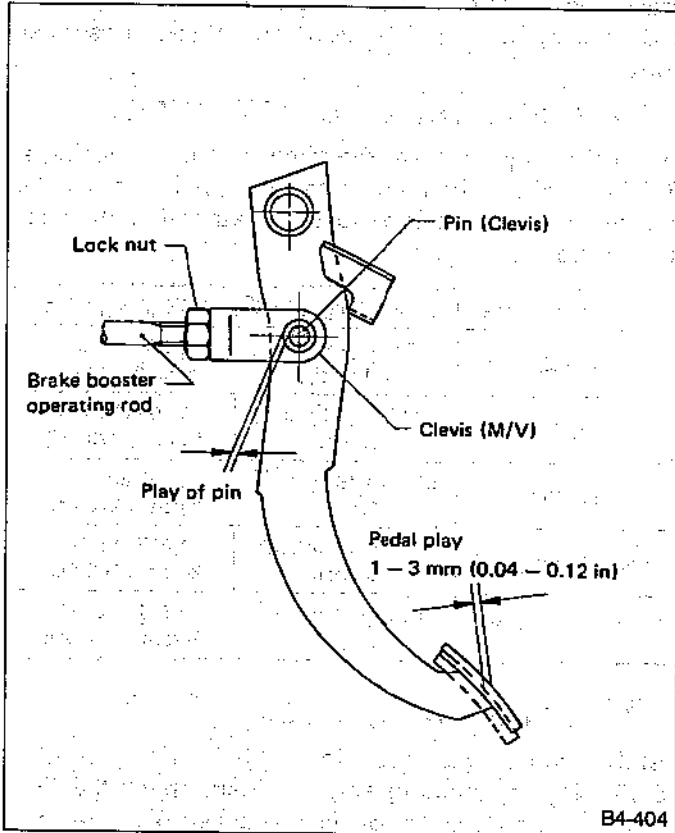


Fig. 128

- (3) Depress the surface of brake pad by hand.
- (4) If there is no free play between clevis pin and clevis, loosen lock nut for operating rod and adjust operating rod by turning in the direction that shortens it.

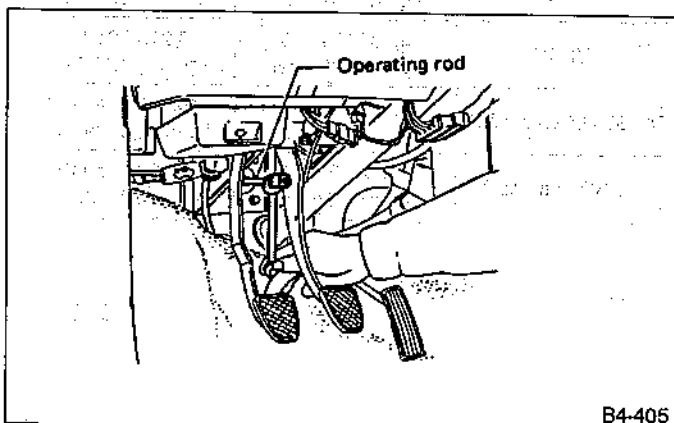


Fig. 129

- 8) Bleed air from brake system.

Torque (Air bleeder screw):

7 — 9 N·m (0.7 — 0.9 kg-m, 5.1 — 6.5 ft-lb)

- 9) Conduct road tests to ensure brakes do not drag.

C: OPERATION CHECK

When checking operation, be sure to securely apply the hand brake.

1. CHECKING WITHOUT USING GAUGES

This method cannot determine the exact portion which has failed, but it can provide a rough understanding of the nature of the failure if checking is conducted in accordance with the following procedure.

2. AIR TIGHTNESS CHECK

Start engine, and run it for 1 to 2 minutes, then turn it off. Depress brake pedal several times applying the same pedal force as that used in ordinary braking operations. The pedal stroke should be greatest on the 1st depression, and it should become smaller with each successive depression. If no change occurs in the pedal height while in a depressed state, brake booster is faulty.

In the event of defective operation, inspect the condition of the check valve and vacuum hose. Replace them if faulty and conduct the test again. If no improvement is observed, check precisely with gauges.

3. OPERATION CHECK

- 1) With engine off, depress brake pedal several times applying the same pedal force and make sure that the pedal height does not vary with each depression of the pedal.
- 2) With brake pedal depressed, start engine.
- 3) As engine starts, brake pedal should move slightly toward the floor. If no change occurs in the pedal height, brake booster is faulty.

If faulty, check precisely with gauges.

4. LOADED AIR TIGHTNESS CHECK

Depress brake pedal while engine is running, and turn off engine while the pedal is still depressed. Keep the pedal depressed for 30 seconds; if no change occurs in the pedal height, brake booster is functioning normally; if the pedal height increases, it is faulty.

If faulty, check precisely with gauges.

5. CHECKING WITH GAUGES

Connect gauges as shown in figure. After bleeding air from pressure gauges, proceed to each check.

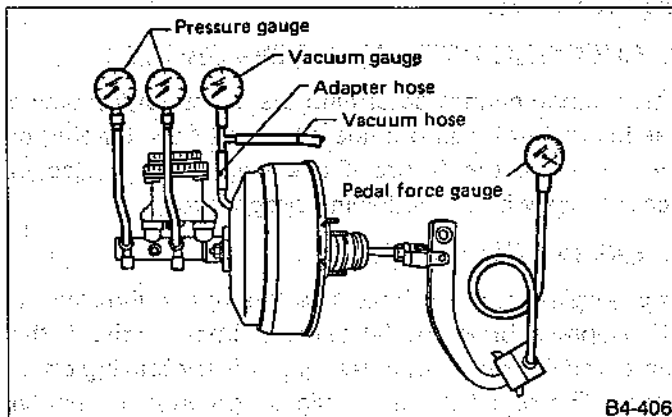


Fig. 130

6. AIR TIGHTNESS CHECK

1) Start engine and keep it running until a vacuum of 66.7 kPa (500 mmHg, 19.69 inHg) is indicated on vacuum gauge. Do not depress brake pedal.

2) Stop engine and watch the gauge. If the vacuum drop range is less than 3.3 kPa (25 mmHg, 0.98 inHg) within 15 seconds after stopping engine, brake booster is functioning properly.

If defective, the cause may be one of those listed below.

- Check valve malfunction
- Leak from vacuum hose
- Leak from the shell jointed portion or stud bolt welded portion
- Damaged diaphragm
- Leak from valve body seal and bearing portion
- Leak from plate & seal ASSY portion
- Leak from poppet valve ASSY portion

7. LOADED AIR TIGHTNESS CHECK

1) Start engine and depress brake pedal with pedal force of 196 N (20 kg, 44 lb). Keep engine running until a vacuum of 66.7 kPa (500 mmHg, 19.69 inHg) is indicated on vacuum gauge while the pedal is still depressed.

2) Stop engine and watch vacuum gauge. If the vacuum drop range is less than 3.3 kPa (25 mmHg, 0.98 inHg) within 15 seconds after stopping engine, brake booster is functioning properly. If defective, refer to "Air tightness check" described above.

8. LACK OF BOOSTING ACTION CHECK

Turn off engine, and set the vacuum gauge reading at "0". Then, check the fluid pressure when brake pedal is depressed. The pressure must be greater than the standard value listed below.

Brake pedal force	147N (15 kg, 33 lb)	294N (30kg, 66 lb)
DL*GL	785 kPa (8 kg/cm ² , 114 psi)	2,158 kPa (22 kg/cm ² , 313 psi)
GX	588 kPa (6 kg/cm ² , 85 psi)	1,963 kPa (19 kg/cm ² , 270 psi)
TURBO	588 kPa (6 kg/cm ² , 85 psi)	1,963 kPa (19 kg/cm ² , 270 psi)
DL*GL*GX with ABS	588 kPa (6 kg/cm ² , 85 psi)	1,667 kPa (17 kg/cm ² , 242 psi)
TURBO with ABS	588 kPa (6 kg/cm ² , 85 psi)	1,667 kPa (17 kg/cm ² , 242 psi)

9. BOOSTING ACTION CHECK

Set the vacuum gauge reading at 66.7 kPa (500 mmHg, 19.69 inHg) by running engine. Then, check the fluid pressure when brake pedal is depressed. The pressure must be greater than the standard value listed below.

Brake pedal force	147N (15 kg, 33 lb)	294N (30kg, 66 lb)
DL*GL	5,492 kPa (56 kg/cm ² , 796 psi)	8,434 kPa (86 kg/cm ² , 1,223 psi)
GX	5,394 kPa (55 kg/cm ² , 782 psi)	9,219 kPa (94 kg/cm ² , 1,337 psi)
TURBO	4,904 kPa (50 kg/cm ² , 711 psi)	9,219 kPa (94 kg/cm ² , 1,337 psi)
DL*GL*GX with ABS	5,394 kPa (55 kg/cm ² , 782 psi)	10,003 kPa (102 kg/cm ² , 1,450 psi)
TURBO with ABS	5,002 kPa (51 kg/cm ² , 725 psi)	10,003 kPa (102 kg/cm ² , 1,450 psi)

D: HANDLING PRECAUTIONS

1) After protector has been removed from push-rod, do not turn the master cylinder side of brake booster downwards.

(1) If the master cylinder side is turned downwards, push-rod may come loose by virtue of its own weight, and reaction disc may drop into brake booster.

(2) Whether or not reaction disc has dropped can be determined by measuring the dimension "L".

The projected amount "L" of pushrod should be as follows:

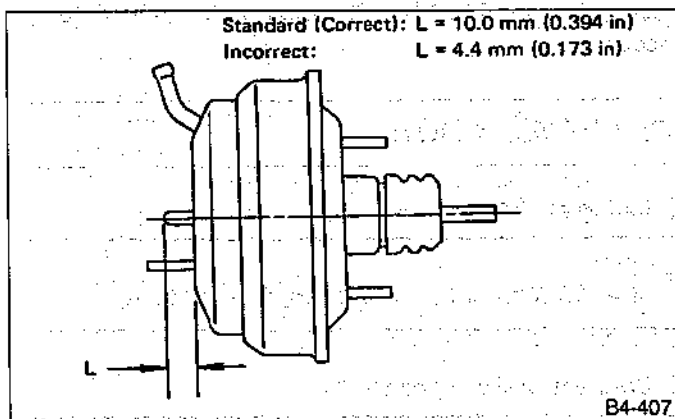


Fig. 131

(3) If protector is fitted correctly, reaction disc will not fall out.

2) Be careful not to drop brake booster. Brake booster should be discarded if it has been dropped.

3) Use special care when handling operating rod. If excessive force is applied to operating rod, sufficient to cause a change in the angle in excess of $\pm 3^\circ$, it may result in damage to the power piston cylinder.

4) Use care when placing brake booster on the floor.

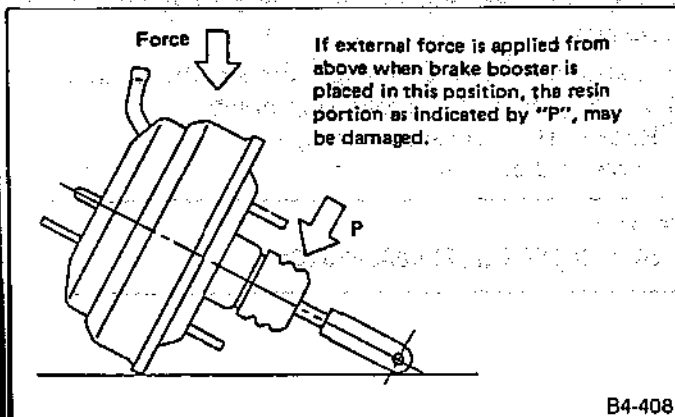


Fig. 132

7. Brake Hose**A: REMOVAL**

- 1) Separate brake pipe from brake hose.
(Always use flare nut wrench and be careful not to deform flare nut.)

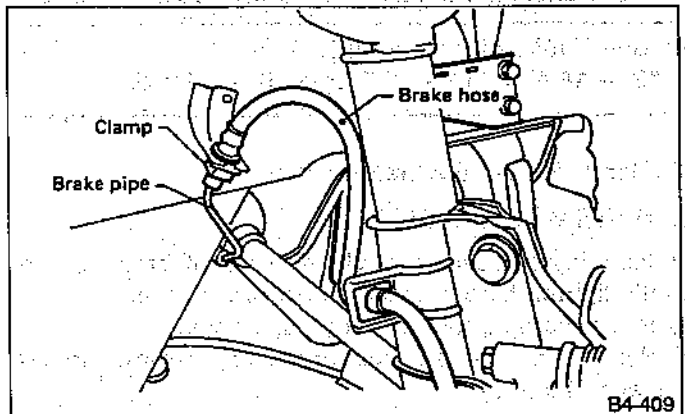


Fig. 133

- 2) Pull out clamp to remove brake hose.
- 3) Remove clamp at strut and union bolt.

B: INSTALLATION**1. FRONT BRAKE HOSE**

- 1) Route end of brake hose (on caliper side) through hole in brake hose bracket at strut location.
- 2) Tighten end of brake hose at caliper using a union bolt.

Torque (Union bolt):

15 — 21 N·m (1.5 — 2.1 kg-m, 11 — 15 ft-lb)

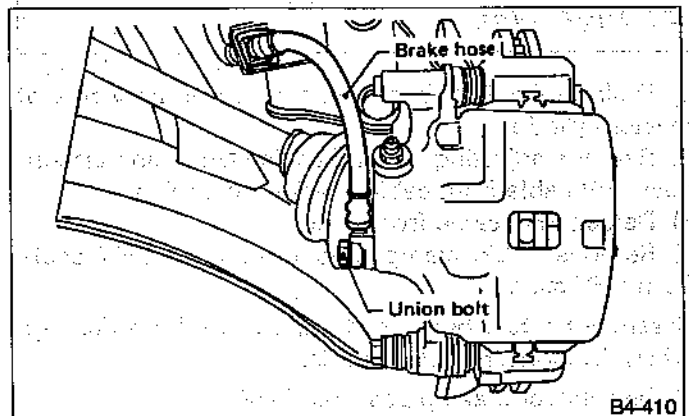


Fig. 134

- 3) Secure middle fitting of brake hose to bracket at strut location using a clamp.

- 4) Position disc in straight-forward direction and route brake hose through hole in bracket on wheel apron side. Be sure brake hose is not twisted.
- 5) Temporarily tighten flare nut to connect brake pipe and hose.
- 6) Fix brake hose with clamp at wheel apron bracket.
- 7) While holding hexagonal part of brake hose fitting with a wrench, tighten flare nut to the specified torque.

Torque (Brake pipe flare nut):

13 — 18 N·m (1.3 — 1.8 kg-m, 9 — 13 ft-lb)

- 8) Bleed air from the brake system.

2. REAR BRAKE HOSE

- 1) Pass brake hose through the hole of bracket, and lightly tighten flare nut to connect brake pipe.
- 2) Insert clamp upward to fix brake hose.
- 3) Perform the same procedures as before-mentioned in steps 7) and 8).

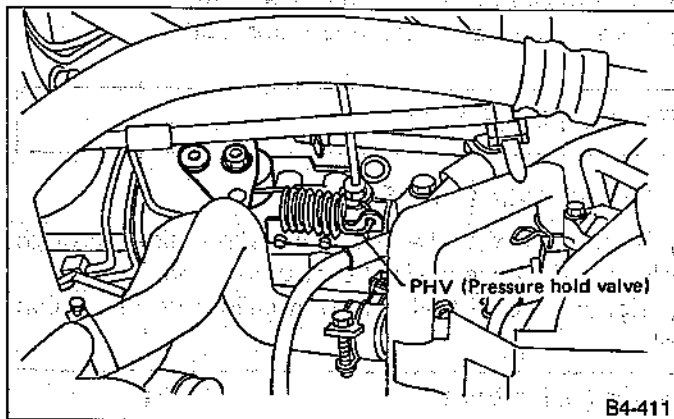
8. Hill-Holder

Fig. 135

A: REMOVAL

- 1) Drain brake fluid from reservoir on primary side of master cylinder.
- 2) Remove adjusting nut and cable clamp, and disconnect PHV cable from cable bracket on engine.
- 3) Detach PHV cable from clips.
- 4) Remove cable clamp, and disconnect PHV cable from PHV stay.

Carefully protect boots and inner cable from damage when disconnecting PHV cable.

- 5) Disconnect brake pipes from PHV.
 - a. Pay attention not to drop brake fluid onto body painting since it may dissolve paint.
 - b. Pay attention not to damage hexagonal head of flare nut by using pipe wrench without fail.
- 6) Detach PHV along with support from side frame.

Exercise utmost care to prevent foreign matter from entering into PHV when removing it.

B: INSPECTION

Check up removed parts as follows, and replace defective ones.

- 1) Check if boots of PHV cable are damaged or degraded, and if inner cable is damaged or corroded.
- 2) Check if return spring is worn out, damaged or corroded.
- 3) Confirm that rolling sound of ball is heard with PHV inclined and lever rotates smoothly.

Never disassemble PHV. Replace entire PHV ASSY if necessary.

C: INSTALLATION

- 1) Install PHV onto side frame.

Torque:

13 — 23 N·m (1.3 — 2.3 kg-m, 9 — 17 ft-lb)

- 2) Connect brake pipes to PHV.

Torque:

13 — 18 N·m (1.3 — 1.8 kg-m, 9 — 13 ft-lb)

Confirm that brake pipes are not deformed and/or damaged. Replace them with new ones if necessary.

- 3) Install PHV cable to PHV stay.
If cable clamp (and clips) is damaged, replace it with a new one.
- 4) Connect PHV cable with clips.

Avoid sharp bending of PHV cable as it may cause breakage.

- 5) Install PHV cable onto cable bracket on engine.
- 6) Apply grease to the following points.
 - Hook portion of return spring
 - Cable end portion of lever

Grease:

SUNLIGHT 2 (P/N 003602010)

7) Be sure to bleed air from the system.

After replacing PHV cable or clutch cable with new one, operate clutch pedal about 30 times as a running-in operation prior to adjustment.

D: ADJUSTMENTS

1) Confirm stopping and starting performances by activating hill-holder on an uphill road of 3° or higher inclination.

(1) If vehicle does not stop;
Tighten adjust nut of PHV cable.

(2) If vehicle does not start properly;

- Case A — When hill-holder is released later than engagement of clutch pedal (Engine tends to stall.):

Loosen adjust nut gradually until smooth starting is enabled.

- Case B — When hill-holder is released earlier than engagement of clutch pedal (Vehicle slips down slightly.):

Tighten adjust nut so that hill-holder is released later than engagement of clutch pedal (status in Case A). Then make adjustment the same as in Case A.

Whenever turning adjust nut, prevent PHV cable from revolving as shown in following figure.

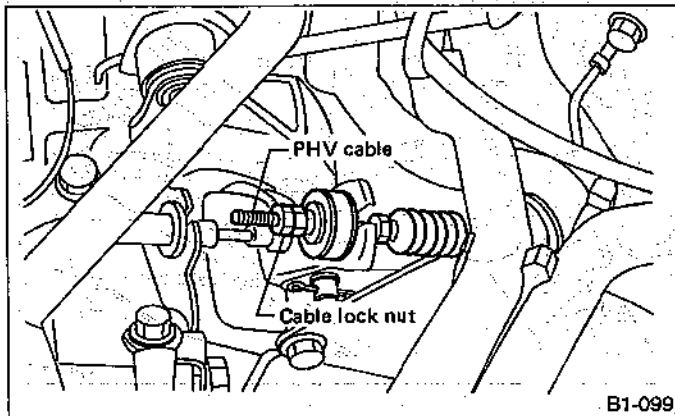


Fig. 136

9. Parking Brake Lever

A: REPLACEMENT

- 1) Remove console box from front floor.
- 2) Disconnect electric connector for parking brake switch.
- 3) Loosen parking brake adjuster, and remove inner cable end from equalizer.
- 4) Remove parking brake lever.
- 5) Install parking brake lever in the reverse order of removal.

Torque (Lever installing bolt):

13 — 23 N·m (1.3 — 2.3 kg·m, 9 — 17 ft·lb)

- 6) Adjust parking brake lever by turning adjuster until parking brake lever stroke is set at 7 to 8 notches with operating force of 196 N (20 kg, 44 lb).

- 7) Tighten lock nut.

Torque (Adjuster lock nut):

4.4 — 7.4 N·m (0.45 — 0.75 kg·m, 3.3 — 5.4 ft·lb)

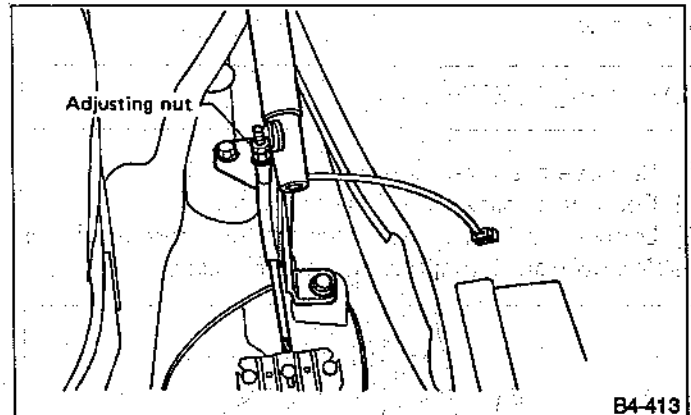
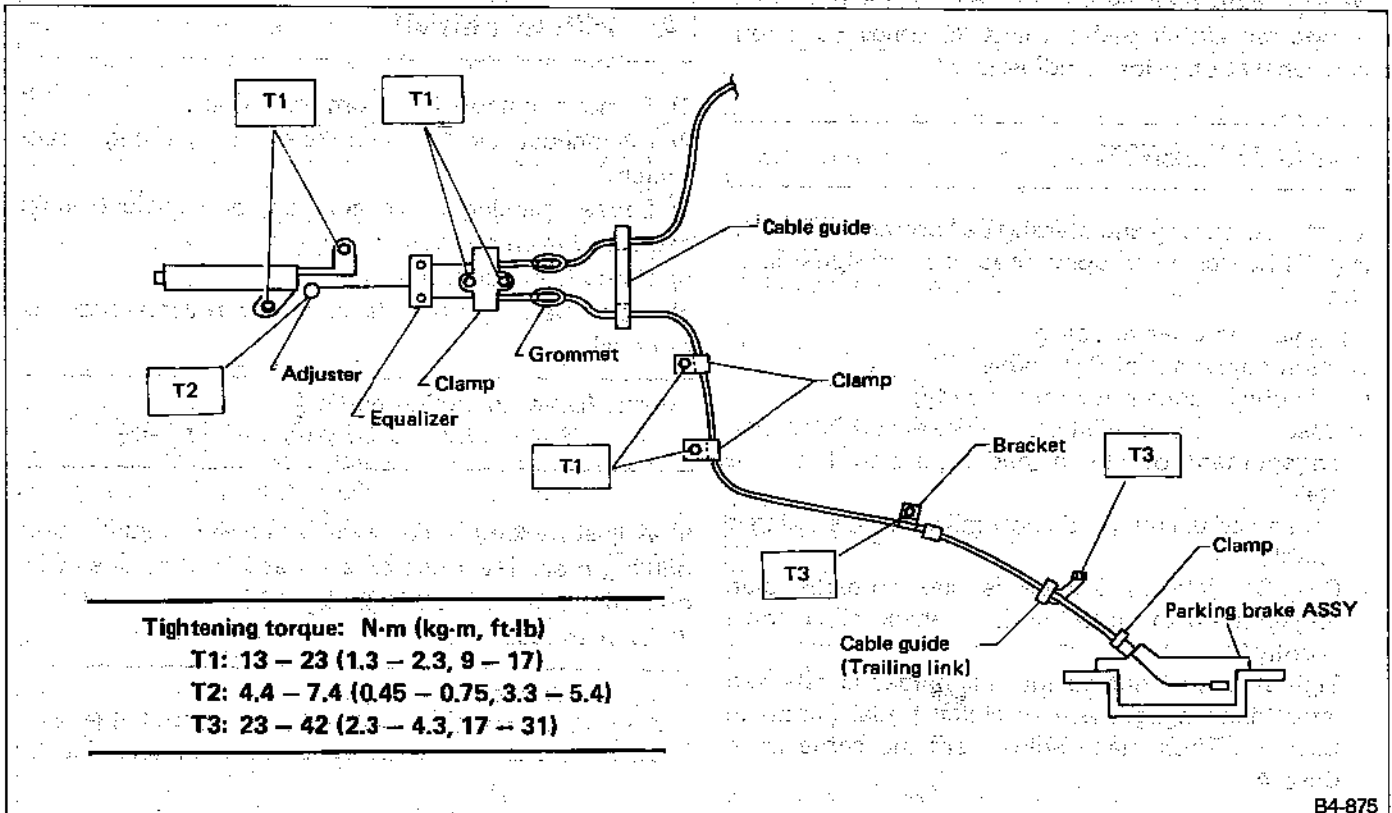


Fig. 137

10. Parking Brake Cable

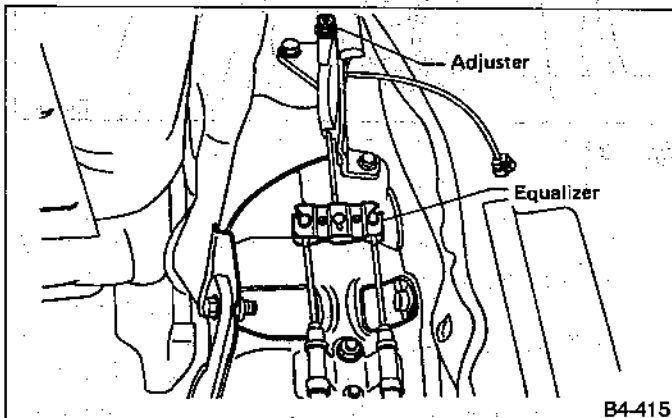


B4-875

Fig. 138

A: REPLACEMENT

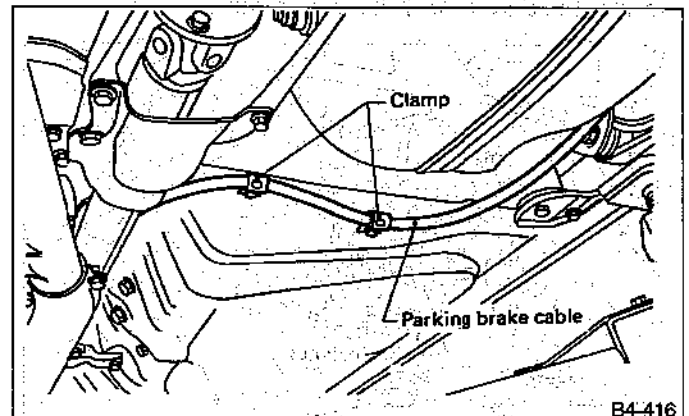
- 1) Remove rear tires and wheels.
- 2) Remove console box from front floor.
- 3) Loosen parking cable adjuster, then remove inner cable end from equalizer, and detach clamps.



B4-415

Fig. 139

- 4) Pull out parking brake cable from parking brake ASSY. (Ref. to 4-4 [W4A0].)
- 5) Pull out clamp from parking brake ASSY.
- 6) Remove bolt and bracket from trailing link bracket.
- 7) Remove bolt and clamp from rear floor.



B4-416

Fig. 140

- 8) Detach grommet from rear floor.
- 9) Remove cable ASSY from cabin by forcibly pulling it backward.
- 10) Detach parking brake cable from cable guide at rear trailing link.
- 11) Install (new) parking brake ASSY in the reverse order of removal.
 - a. Be sure to pass cable through cable guide inside the tunnel.
 - b. Be sure to adjust the lever stroke. (Refer to 4-4 [W4D1].)

11. Air Bleeding

A: BLEEDING PROCEDURE

- The FMVSS No. 116, fresh DOT3 or 4 brake fluid must be used.
- Cover bleeder with waste cloth, when loosening it, to prevent brake fluid from being splashed over surrounding parts.
- Avoid mixing different brands of brake fluid to prevent degrading the quality of the fluid.
- Be careful not to allow dirt or dust to get into the reservoir tank.
- During bleeding operation, keep the brake reserve tank filled with brake fluid to eliminate entry of air.
- Brake pedal operating must be very slow.
- For convenience and safety, it is advisable to have two man working.
 - Make sure that there is no leak from joints and connections of the brake system.
 - Fit one end of vinyl tube into the air bleeder and put the other end into a brake fluid container.

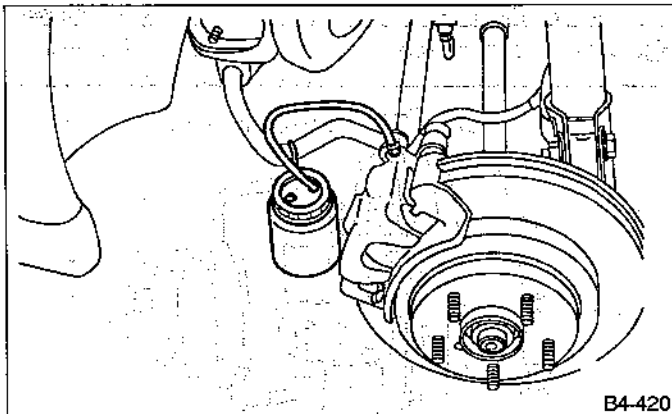


Fig. 141

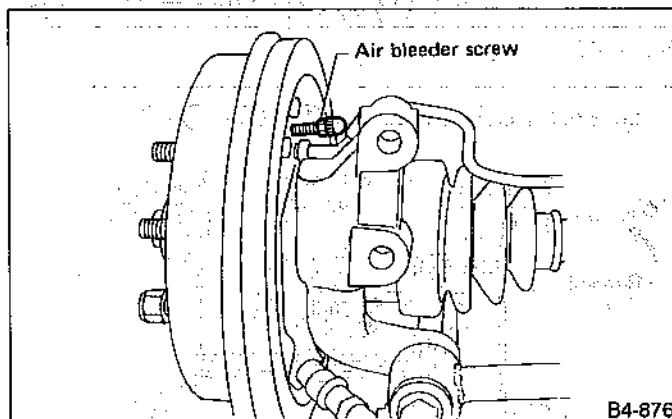


Fig. 142

- Slowly depress the brake pedal and keep it depressed. Then, open the air bleeder to discharge air together with the fluid. Release air bleeder for 1 to 2 seconds.

Next, with the bleeder closed, slowly release the brake pedal.

Repeat these steps until there are no more air bubbles in the vinyl tube.

Allow 3 to 4 seconds between two brake pedal operations.

4) Tighten air bleeder securely when no air bubbles are visible.

Tightening torque (Bleeder screw):

7 — 9 N·m (0.7 — 0.9 kg-m, 5.1 — 6.5 ft-lb)

5) Bleed air from brake system in numerical sequence shown in Figure 143 and 144 using above steps as a guide.

Air bleeding of hydraulic unit is performed only on ABS equipped models.

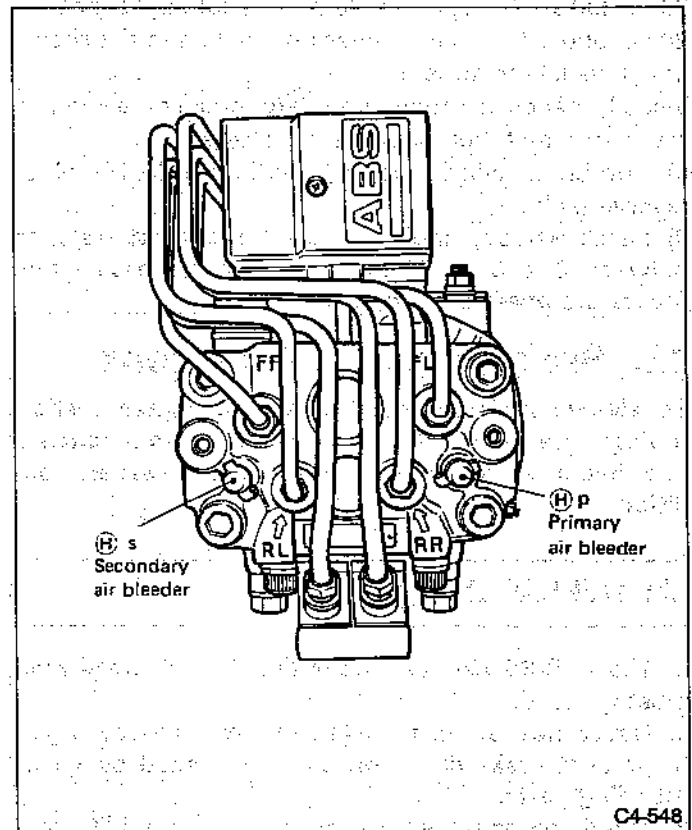


Fig. 143 Hydraulic unit

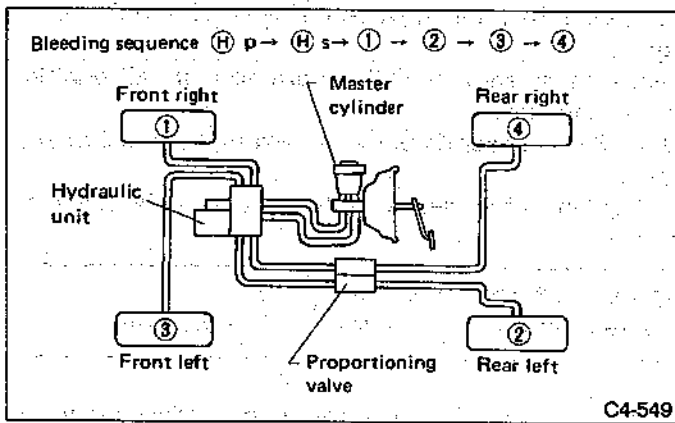


Fig. 144

6) If the pedal action is soft and spongy, or pedal travels excessively, the system must be bled of air again.
7) Depress brake pedal with a force of approximately 294 N (30 kg, 66 lb) and hold it there for approximately 20 seconds. At this time check pedal to see if it shows any unusual movement.

Visually inspect bleeder screws and brake pipe joints to make sure that there is no fluid leakage.

8) Add brake fluid to the required level (MAX level) of reserve tank.

9) Install wheels, and drive car for a short distance between 2 to 3 km (1 to 2 miles) to make sure that brakes are operating properly.

12. Brake Fluid Replacement

To always maintain the brake fluid characteristics, replace the brake fluid according to maintenance schedule or earlier than that when used in severe condition.

A: REPLACEMENT

- The FMVSS No. 116, fresh DOT3 or 4 brake fluid must be used.
- Cover bleeder with waste cloth, when loosening it, to prevent brake fluid from being splashed over surrounding parts.
- Avoid mixing different brands of brake fluid to prevent degrading the quality of the fluid.
- Be careful not to allow dirt or dust to get into the reservoir tank.
- During bleeding operation, keep the brake reserve tank filled with brake fluid to eliminate entry of air.
- Brake pedal operating must be very slow.
- For convenience and safety, it is advisable to have two man working.
- The amount of brake fluid required is approximately 300 ml (10.1 US fl oz, 10.6 Imp fl oz) for total brake system.

1) Either jack up vehicle and place a safety stand under it, or left up vehicle.

- Remove both front and rear wheels.
- Draw out the brake fluid from master cylinder with syringe.
- Refill reservoir tank with recommended brake fluid.

Recommended brake fluid

FMVSS No. 116, fresh DOT3 or 4 brake fluid

- Install one end of a vinyl tube onto the air bleeder of and insert the other end of the tube into a container to collect the brake fluid.

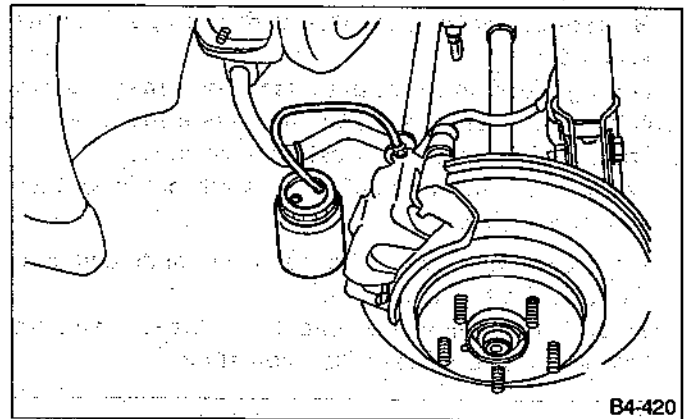


Fig. 145

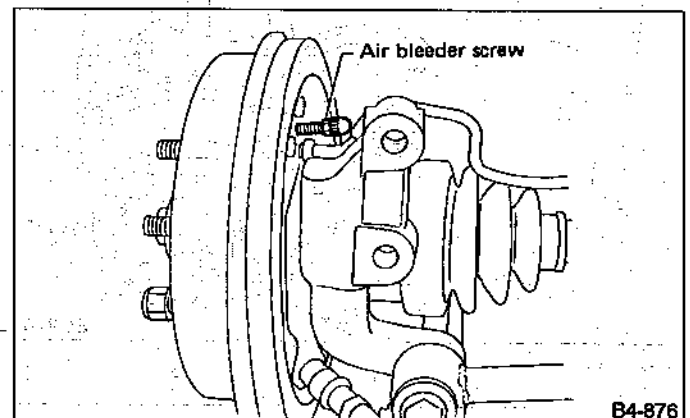


Fig. 146

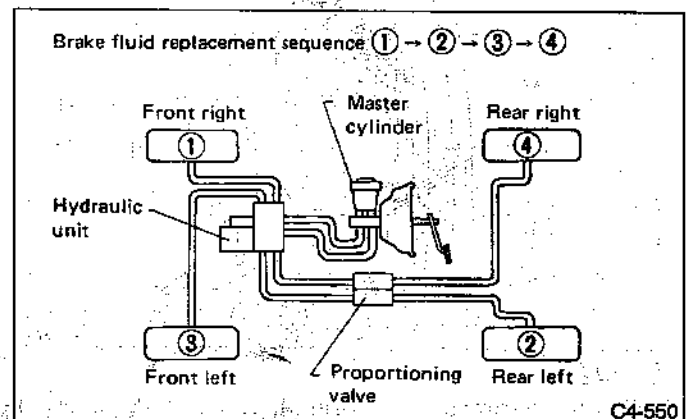


Fig. 147

- Instruct your co-worker to depress the brake pedal slowly two or three times and then hold it depressed.

7) Loosen bleeder screw approximately 1/4 turn until a small amount of brake fluid drains into container, and then quickly tighten screw.

8) Repeat steps 6) and 7) above until there are no air bubbles in drained brake fluid and new fluid flows through vinyl tube.

Add brake fluid as necessary while performing the air bleed operation, in order to prevent the tank from running short of brake fluid.

9) After completing the bleeding operation, hold brake pedal depressed and tighten screw and install bleeder cap.

Tightening torque (Bleeder screw):

7 — 9 N·m (0.7 — 0.9 kg-m, 5.1 — 6.5 ft-lb)

10) Bleed air from each wheel cylinder using the same procedures as described in steps 6) through 7) above.

11) Depress brake pedal with a force of approximately 294 N (30 kg, 66 lb) and hold it there for approximately 20 seconds. At this time check pedal to see if it shows any unusual movement.

Visually inspect bleeder screws and brake pipe joints to make sure that there is no fluid leakage.

12) Install wheels, and drive car for a short distance between 2 to 3 km (1 to 2 miles) to make sure that brakes are operating properly.

13. Proportioning Valve

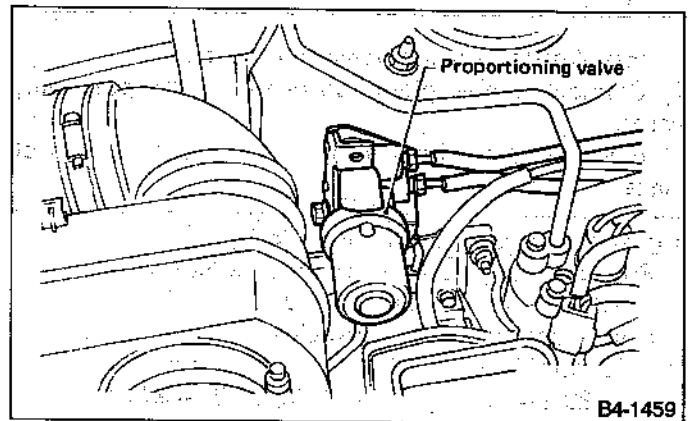


Fig. 148 (ABS equipped model)

A: INSPECTION

- 1) Install the oil pressure gauges to measure the master cylinder fluid pressure (front wheel brake fluid pressure) and rear wheel cylinder fluid pressure.
- 2) Bleed air from the oil pressure gauges.
- 3) Check the master cylinder fluid pressure and rear wheel cylinder fluid pressure.

The standard values are shown in figure.

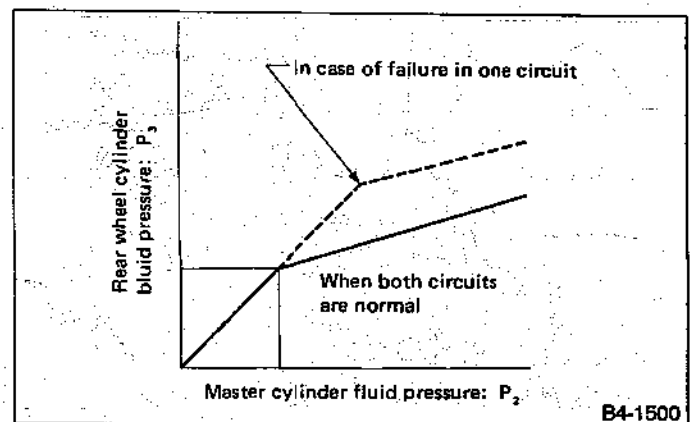


Fig. 149

- 4) For the oil pressure in case of split point, refer to A: SPECIFICATIONS [S0A0].

B: REMOVAL

- 1) Remove brake pipe from proportioning valve at four places.
- 2) Remove proportioning valve from its bracket.

Do not disassemble or adjust the proportioning valve. (The proportioning valve must be replaced as an assembly.)

C: INSTALLATION

- 1) Install proportioning valve to bracket.
- 2) Connect brake pipes correctly to proportioning valve.
- 3) Bleed air, then check each joint of brake pipe for oil leaks.

Tightening torque: N·m (kg-m, ft-lb)

Proportioning valve to brake pipe flare nut

13 — 18 (1.3 — 1.8, 9 — 13)

Proportioning valve to bracket

Normal brake vehicle:

20.1 — 28.9 (2.05 — 2.95, 14.8 — 21.3)

ABS equipped vehicle:

13 — 23 (1.3 — 2.3, 9 — 17)

14. ABS Sensor**A: REMOVAL**

- 1) Disconnect front ABS sensor located in engine compartment.
- 2) Remove bolts which secure sensor harness to bracket.

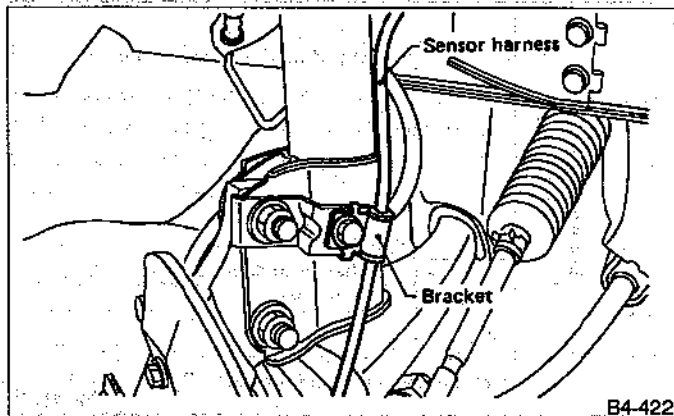


Fig. 150

- 3) Remove bolts which secure front ABS sensor to housing, and remove front ABS sensor.

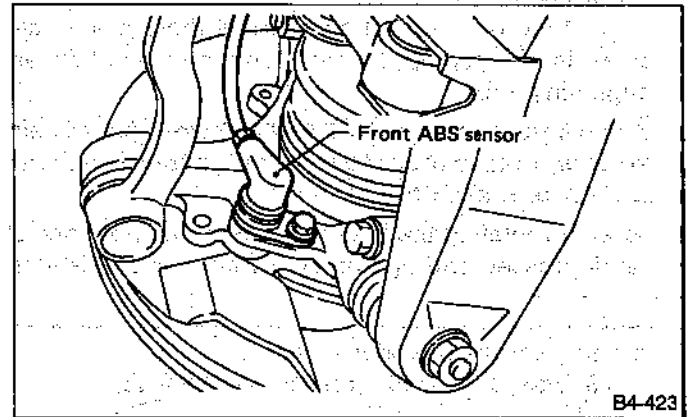


Fig. 151

Be careful not to damage pole piece located at tip of the sensor during removal.

- 4) Remove front disc brake caliper and disc rotor from housing after removing front tire.
- 5) Remove front drive shaft and housing & hub ASSY. (Ref. to 4-2 [W1A0].)
- 6) Remove tone wheel while removing hub from housing & hub ASSY. (Ref. to 4-2 [W1B0].)

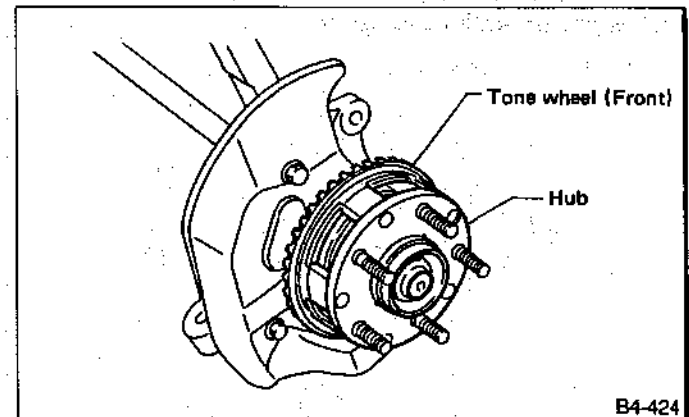
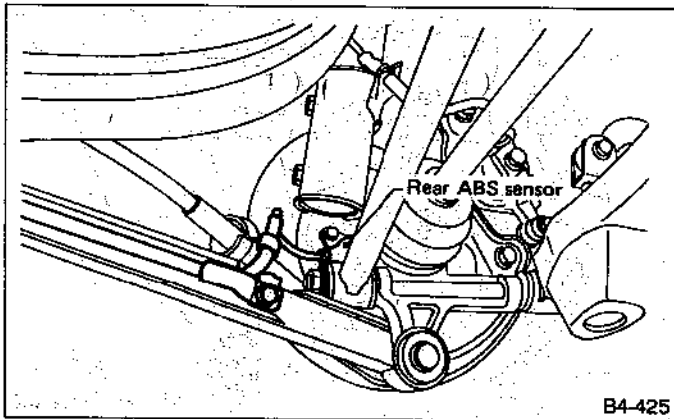


Fig. 152

Be careful not to damage teeth faces of tone wheel during removal.

- 7) Remove rear seat and disconnect rear speed sensor connector.
- 8) Remove rear sensor harness bracket from rear trailing link.
- 9) Remove rear back plate from rear speed sensor.



B4-425

Fig. 153

10) Remove rear tone wheel while removing hub from housing & hub ASSY. (Ref. to 4-2 [W3A0].)

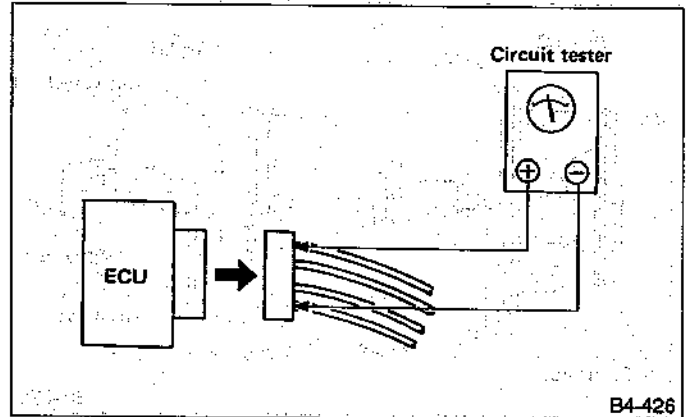
- a. Be careful not to damage pole piece of sensor and teeth faces.
- b. Do not pull sensor harness during removal.

B: INSPECTION

1. ABS SENSOR

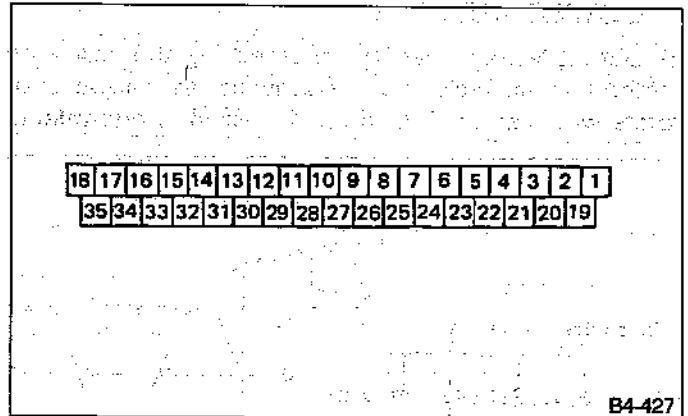
- 1) Check pole piece of speed sensor for foreign particles or damage. If necessary, clean pole piece or replace ABS sensor.
- 2) Measure resistance between ABS sensor terminals.

ABS sensor	Model	Terminal No.	Standard
Front - LH	4WD	22 and 4	1.0 ± 0.2 kΩ
	FWD	5 and 4	
Front - RH	ALL	11 and 2	
Rear - LH	ALL	7 and 9	
Rear - RH	ALL	24 and 25	
Front - LH	4WD	22 and 10, 20, 34	
	FWD	5 and 10, 20, 34	
Front - RH	ALL	11 and 10, 20, 34	
Rear - LH	ALL	7 and 10, 20, 34	
Rear - RH	ALL	24 and 10, 20, 34	



B4-426

Fig. 154



B4-427

Fig. 155

- a. If resistance is outside the standard value, replace ABS sensor with new one or adjust sensor gap between ABS sensor and tone wheel.
- b. Check ABS sensor cable for discontinuity. If necessary, replace with a new one.

2. TONE WHEEL

- 1) Check tone wheel's teeth (44 pieces) for cracks or dents. If necessary, replace tone wheel with a new one.
- 2) Clearances (sensor gaps) should be measured one by one to ensure tone wheel and ABS sensor are installed correctly.

ABS sensor clearance:

- Front
 - 0.9 — 1.4 mm (0.035 — 0.055 in)
- Rear
 - 0.7 — 1.2 mm (0.028 — 0.047 in)

- a. If clearance is narrow, adjust by using spacer (P/# 26755AA000)
- b. If clearance is wide, check the outputted voltage then replace ABS sensor or tone wheel if the outputted voltage is outside the specification.

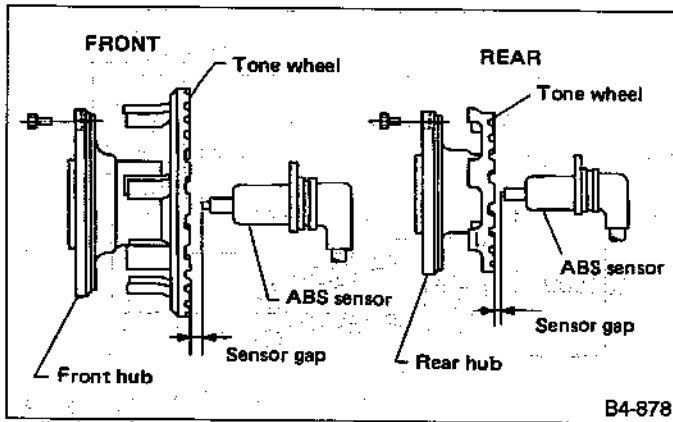


Fig. 156

3. OUTPUT VOLTAGE

1) Output voltage can be checked by the following method. Install resistor and condenser as follows, then rotate wheel about 2.75 km/h (1.7 MPH) or equivalent.

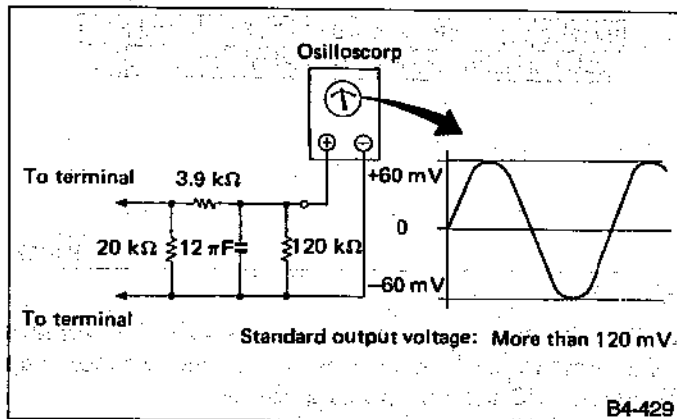


Fig. 157

Regarding terminal No., please refer to item ABS SENSOR.

C: INSTALLATION

1. FRONT ABS SENSOR

- 1) Install tone wheel on hub, then install housing on hub ASSY. (Ref. to 4-2 [W1D0].)
- 2) Temporarily install front ABS sensor on housing.

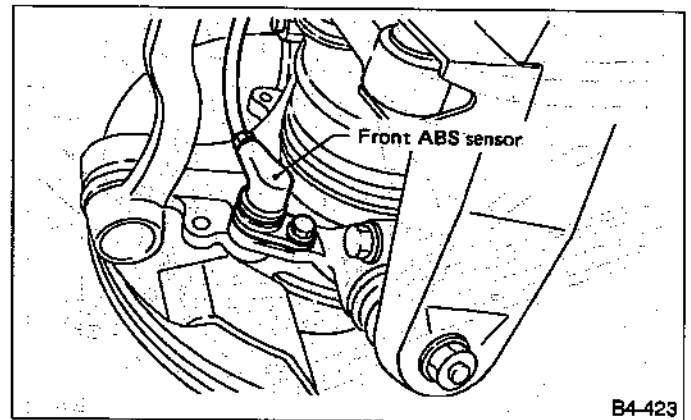


Fig. 158

Be careful not to strike ABS sensor's pole piece and tone wheel's teeth against adjacent metal parts during installation.

- 3) Install front driver shaft to hub spline and transmission spindle. (Ref. to 4-2 [W1D0].)
- 4) Install front ABS sensor on strut and wheel apron bracket.

Tightening torque:

23 — 42 N·m (2.3 — 4.3 kg-m, 17 — 31 ft-lb)

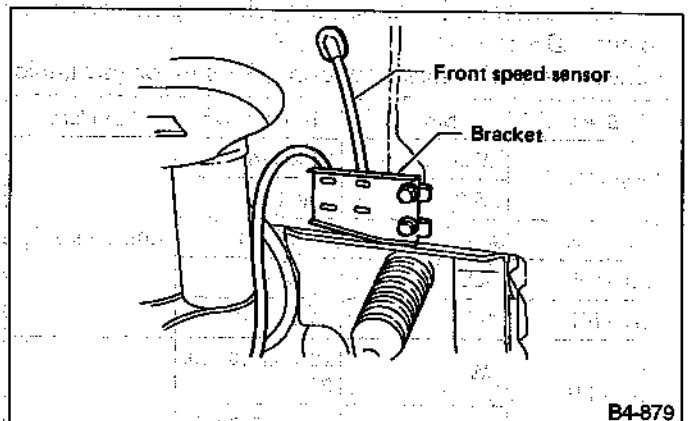


Fig. 159

5) Place a thickness gauge between ABS sensor's pole piece and tone wheel's tooth face. After standard clearance is obtained over the entire perimeter, tighten ABS sensor on housing to specified torque.

ABS sensor standard clearance:

0.9 — 1.4 mm (0.035 — 0.055 in)

Tightening torque:

23 — 42 N·m (2.3 — 4.3 kg-m, 17 — 31 ft-lb)

If the clearance is outside specifications, readjust.

2. REAR ABS SENSOR

- 1) Install rear tone wheel on hub, then rear housing on hub COMPL. (Ref. to 4-2.)
- 2) Temporarily install rear ABS sensor on back plate.

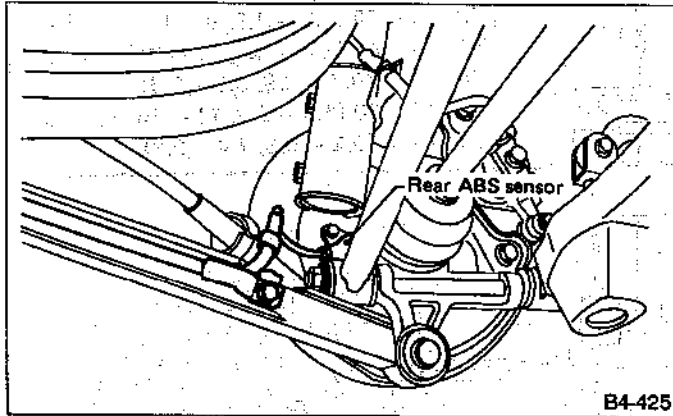


Fig. 160

Be careful not to strike ABS sensor's pole piece and tone wheel's teeth against adjacent metal parts.

- 3) Install rear drive shaft to rear housing and rear differential spindle. (Ref. to 4-2.)
- 4) Install rear sensor harness on rear trailing link.

Tightening torque:

23 — 42 N·m (2.3 — 4.3 kg-m, 17 — 31 ft-lb)

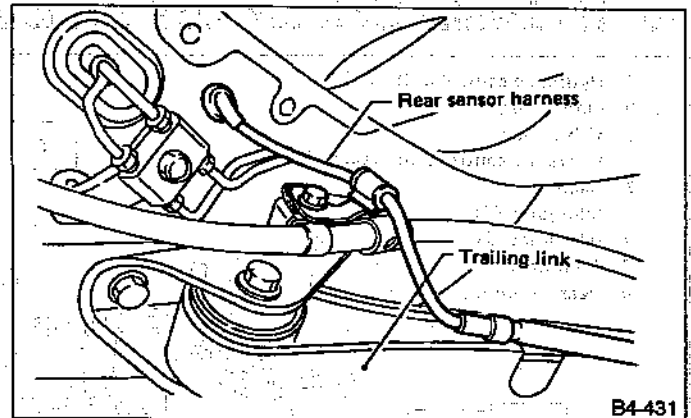


Fig. 161

- 5) Place a thickness gauge between ABS sensor's pole piece and tone wheel's tooth face. After standard clearance is obtained over the entire perimeter, tighten ABS sensor on back plate to specified torque.

Speed sensor standard clearance:

0.7 — 1.2 mm (0.028 — 0.047 in)

Tightening torque:

23 — 42 N·m (2.3 — 4.3 kg-m, 17 — 31 ft-lb)

If the clearance is outside specifications, readjust.

15. Hydraulic Unit for ABS System

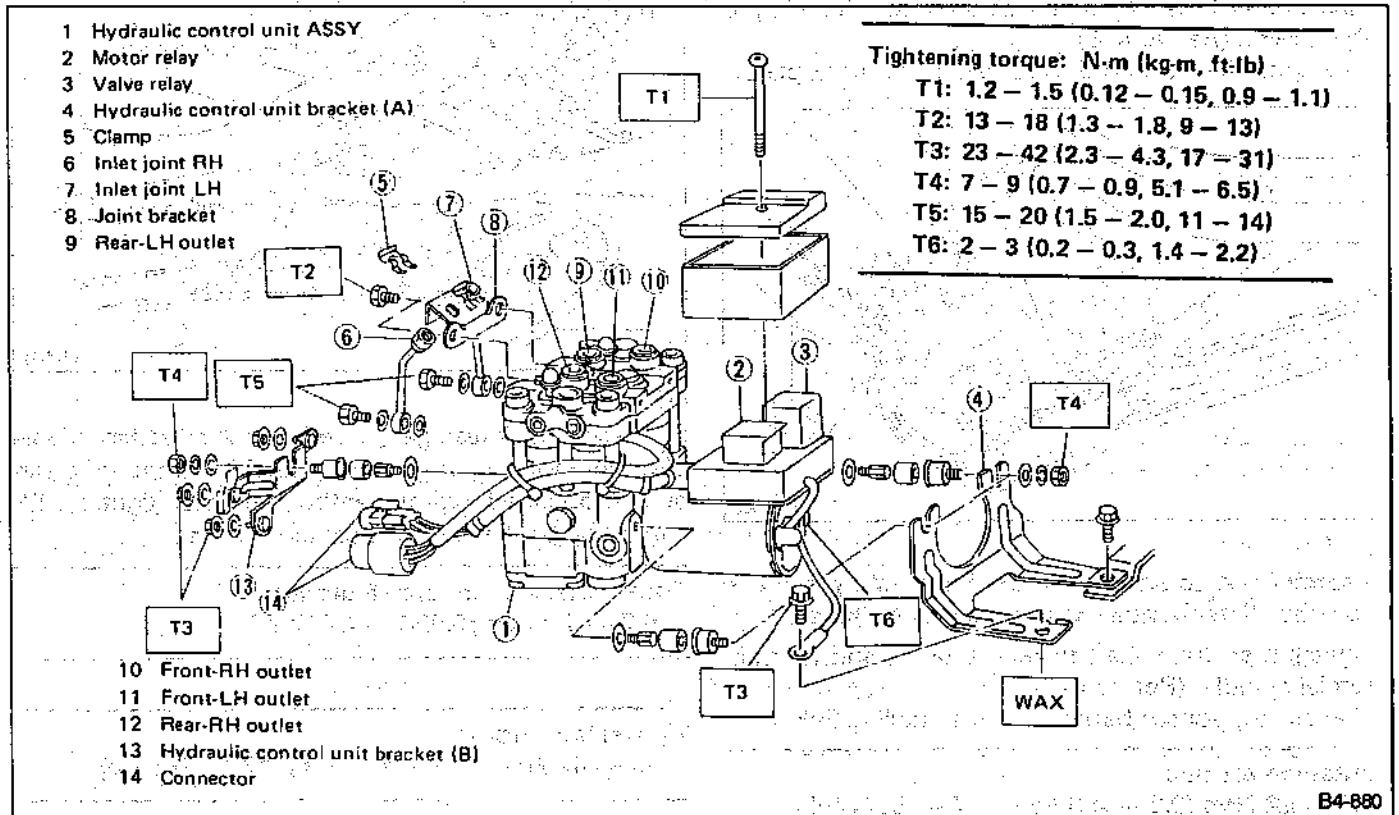


Fig. 162 (NIPPON ABS)

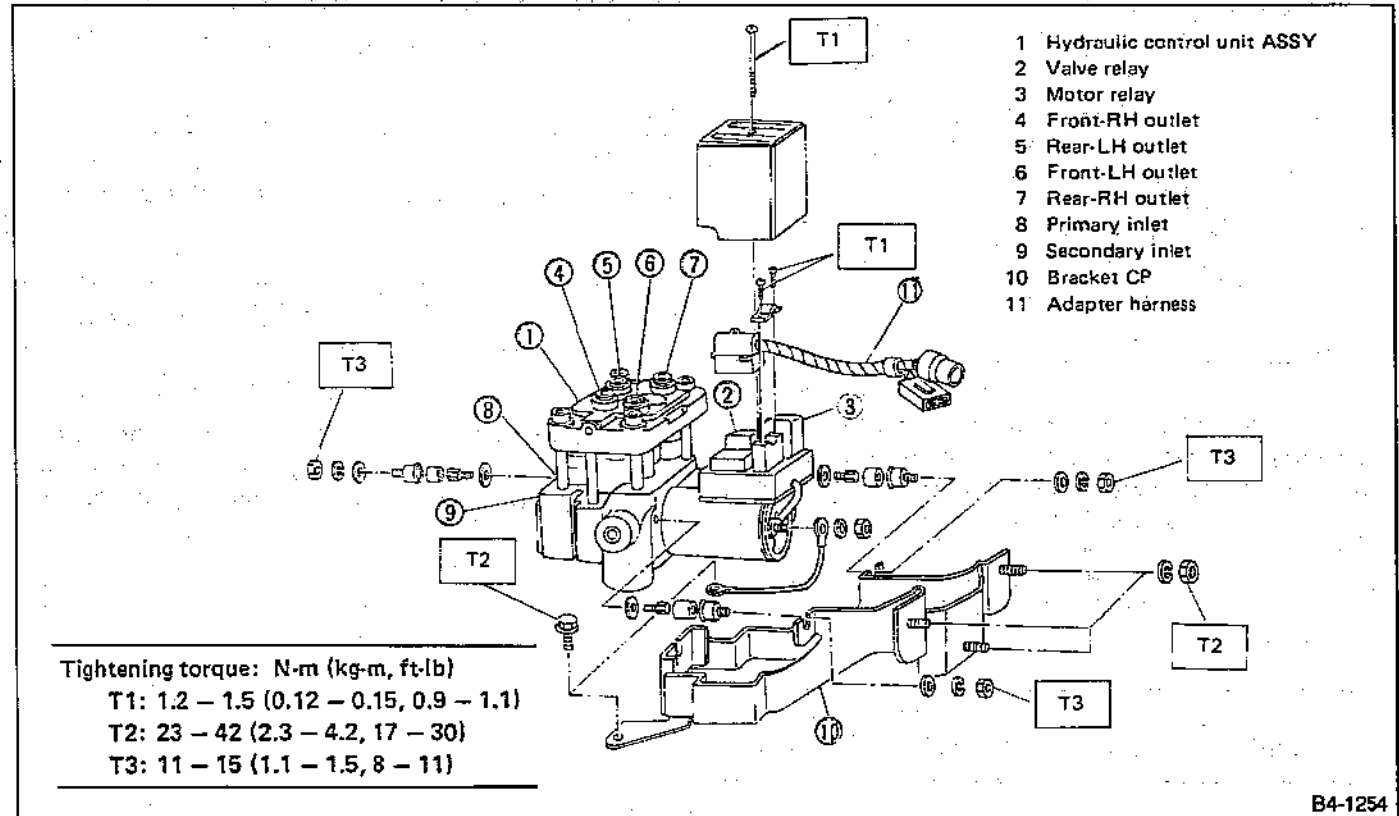
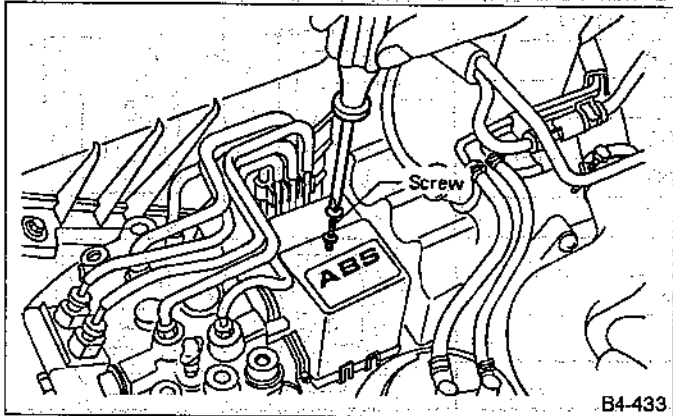


Fig. 163 (BOSCH ABS)

A: REMOVAL

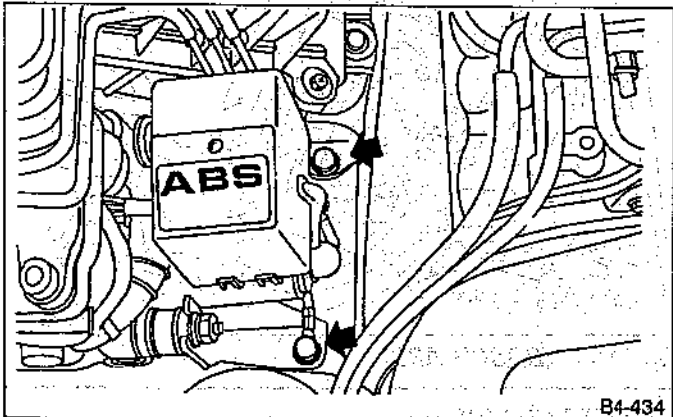
- 1) Remove canister from engine compartment to facilitate removal of hydraulic unit.
- 2) Disconnect brake pipes from hydraulic unit and plug open joints to prevent entry of foreign particles.
- 3) Remove screws which secure hydraulic unit's relay box cover.



B4-433

Fig. 164

- 4) Remove bolts which secure hydraulic unit to bracket, and remove hydraulic unit from engine compartment.



B4-434

Fig. 165

- a. Hydraulic unit cannot be disassembled. Do not attempt to loosen bolts and nuts.
- b. Do not drop or bump hydraulic unit.
- c. Do not turn the hydraulic unit upside down or place it on its side.
- d. Be careful to prevent foreign particles from getting into hydraulic unit.
- e. When a new hydraulic unit is installed, apply a coat of rust-preventive wax (Nippeco LT or GB) to bracket attaching bolts after tightening.
- f. Do not pull harness disconnecting harness connector.

B: INSPECTION

- 1) Check bracket (on vehicle) for looseness.
- 2) Check connected and fixed condition of connector.
- 3) Open hydraulic unit relay box and check for discontinuity or short-circuits.

	Condition	Terminal number	Standard	Diagram	Terminal location
Valve relay	Turning off electricity.	85 — 86	93 — 113 Ω		
		30 — 87a	0 Ω		
		30 — 87	∞		
	Turning on electricity between 85 and 86. (DC 12 V)	30 — 87a	0Ω		
		30 — 87	0Ω		
			—		
Motor relay	Turning off electricity.	85 — 88	72 — 88 Ω		
		30 — 87	∞		
	Turning on electricity between 85 and 86. (DC 12 V)	30 — 87	0 Ω		

B4-435

Fig. 166

C: INSTALLATION

- 1) Install relay box cover on hydraulic unit.

Tightening torque:

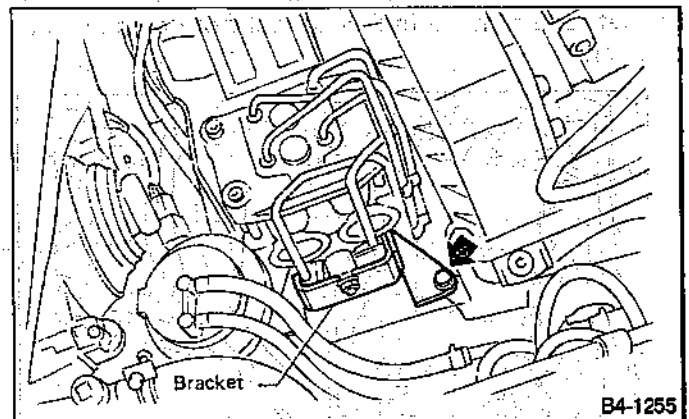
1.2 — 1.5 N·m (0.12 — 0.15 kg-m, 0.9 — 1.1 ft-lb)

- 2) Install hydraulic unit after tightening bracket and motor ground lead as a unit.

Tightening torque:

23 — 42 N·m (2.3 — 4.3 kg-m, 17 — 31 ft-lb)

- 3) Connect brake pipes to their correct hydraulic unit connections.

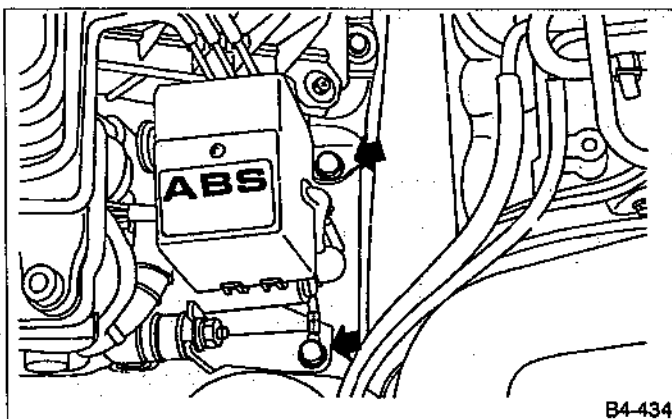


B4-1255

Fig. 168 (BOSCH ABS)

Tightening torque:

13 — 18 N·m (1.3 — 1.8 kg-m, 9 — 13 ft-lb)



B4-434

Fig. 167 (NIPPON ABS)

16. Electronic Control Unit for ABS System

A: REMOVAL

- 1) Remove floor mat located under lower right side of front seat.
- 2) Remove bolts which secure electronic control unit to body.

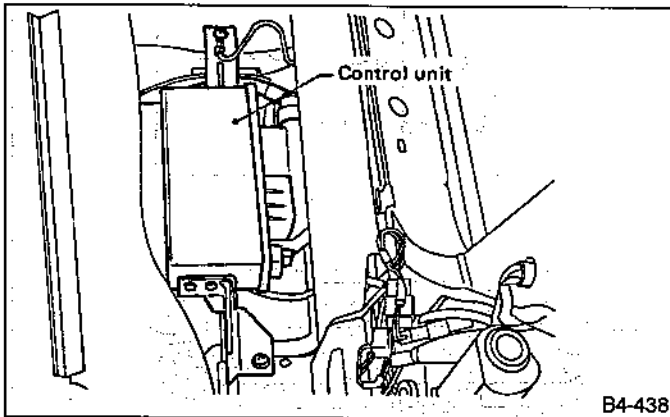


Fig. 169

- 3) Remove screws which secure connector to electronic control unit and disconnect connector.

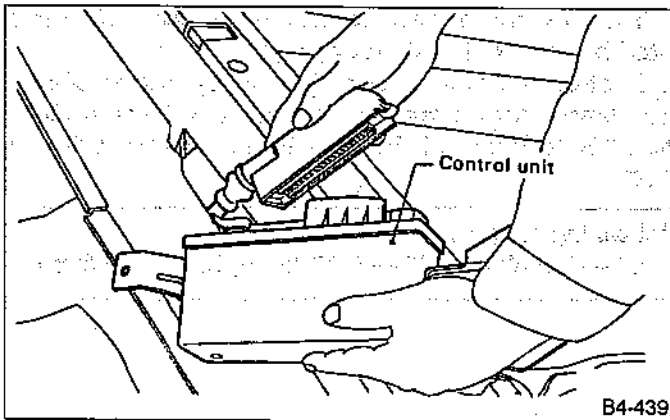


Fig. 170

B: INSPECTION

Check that connector is connected correctly and that connector terminal sliding resistance is correct.

C: INSTALLATION

- 1) Connect connector to electronic control unit.

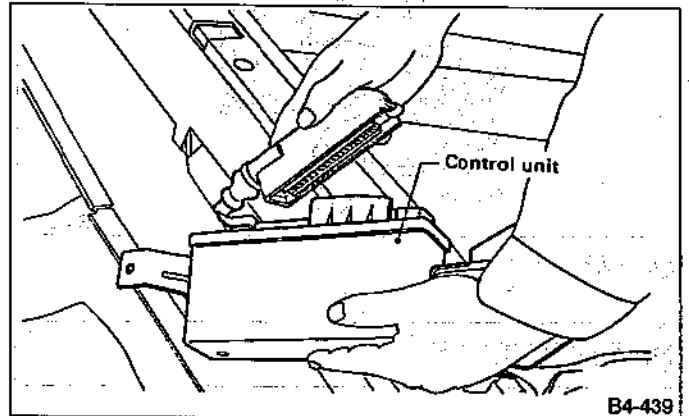


Fig. 171

- 2) Install electronic control unit on body.

17. G Sensor for ABS System

A: REMOVAL AND INSTALLATION

The G sensor is located on the right front wheel apron.

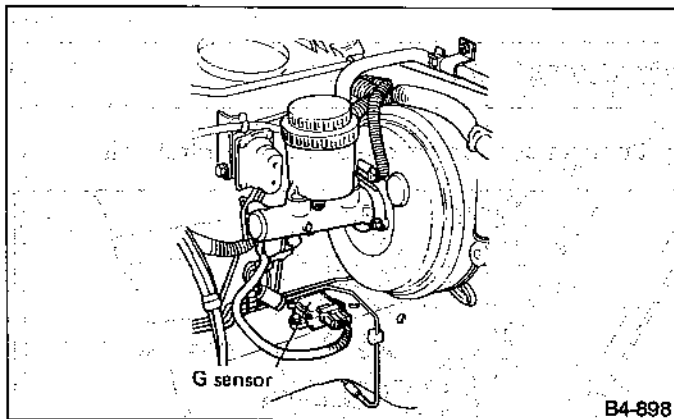


Fig. 172

B: INSPECTION

- 1) Check to ensure that G sensor is securely installed on front wheel apron, and that connector is properly installed.
- 2) Disconnect connector from G sensor and measure contact resistance between terminals.

Condition of G sensor	Standard
On flat surface	$610 \pm 60 \Omega$
* When slanting about $14^\circ - 21.3^\circ (\theta)$	$610 \pm 60 \Omega \rightarrow$ More than $100 \text{ k}\Omega$

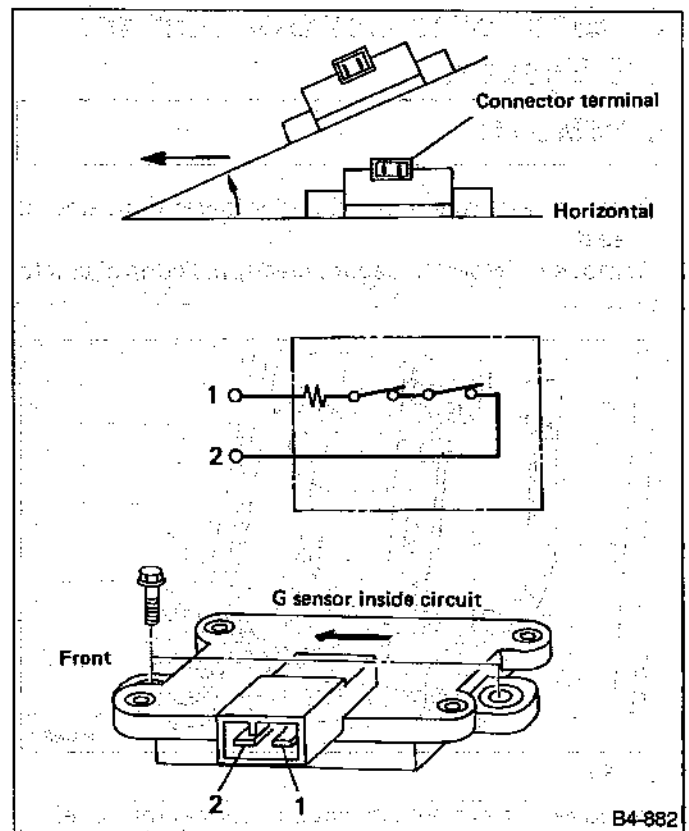


Fig. 173

- a. Tilt G sensor forward as shown in Figure 173. If it is tilted backward, it will not operate.
- b. Hysteresis occurs during ON-OFF operation of sensor. Sensor should turn OFF from ON ($610 \Omega \rightarrow$ More than $100 \text{ k}\Omega$) when it is tilted in a range from 14° to 21.3° .

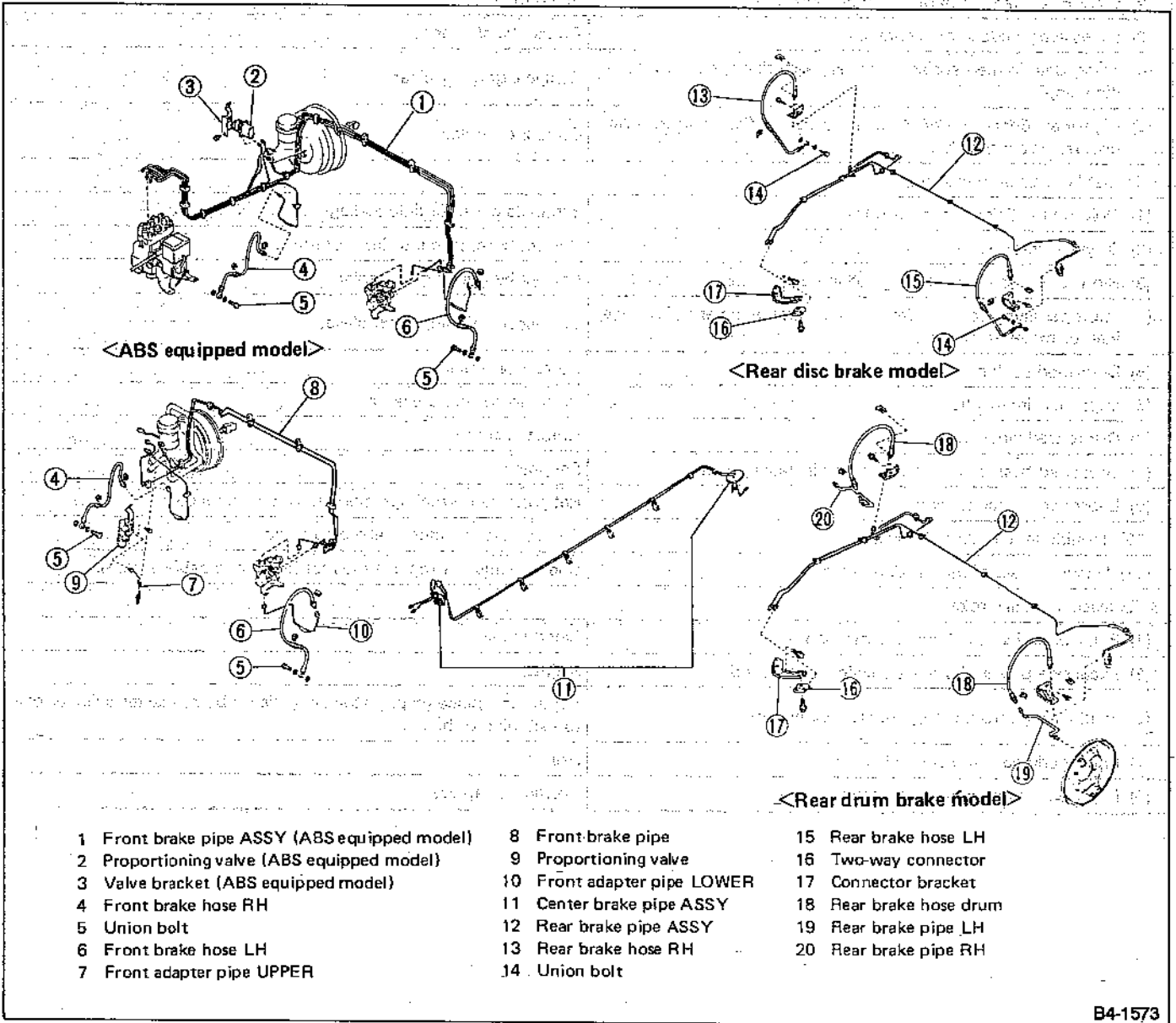
Tightening torque:

$7.2 - 7.6 \text{ N}\cdot\text{m}$ ($0.73 - 0.77 \text{ kg}\cdot\text{m}$, $5.3 - 5.6 \text{ ft}\cdot\text{lb}$)

18. Brake Hose and Pipe

A: REMOVAL AND INSTALLATION

- a. When removing and installing the brake pipe, make sure that it is not bent.
- b. After installing the brake pipe and hose, bleed the air.
- c. After installing the brake hose, make sure that it does not touch the tire or suspension ASSY, etc.



B4-1573

Fig. 174

T TROUBLESHOOTING

1. Entire Brake System

Trouble and possible cause	Corrective action
1. Insufficient braking	
(1) Fluid leakage from the hydraulic mechanism	Repair or replace (cup, piston seal, piston boot, master cylinder piston kit, pipe or hose).
(2) Entry of air into the hydraulic mechanism	Bleed the air.
(3) Excessively wide shoe clearance	Adjust the clearance.
(4) Wear, deteriorated surface material, adhering water or fluid on the lining	Replace, grind or clean.
(5) Improper operation of master cylinder, disc caliper, brake booster or check valve	Correct or replace.
2. Unstable or uneven braking	
(1) Fluid on the lining, drum or rotor	Eliminate cause of fluid leakage, clean, or replace.
(2) Drum or rotor eccentricity	Correct or replace the drum or rotor.
(3) Worn brake drum, or damage to the drum caused by sand	Correct by grinding, or replace.
(4) Improper lining contact, deteriorated surface material, improper inferior material, or wear	Correct by grinding, or replace.
(5) Deformed back plate	Correct or replace.
(6) Improper tire inflation	Inflate to correct pressure.
(7) Disordered wheel alignment	Adjust alignment.
(8) Loosened back plate or the support installing bolts	Retighten.
(9) Loosened wheel bearing	Retighten to normal tightening torque or replace.
(10) Trouble in the hydraulic system	Replace the cylinder, brake pipe or hose.
(11) Uneven effect of the parking brake	Check, adjust, or replace the rear brake and cable system.
3. Excessive pedal stroke	
(1) Entry of air into the hydraulic mechanism	Bleed the air.
(2) Excessive play in the master cylinder push rod	Adjust.
(3) Fluid leakage from the hydraulic mechanism	Repair or replace (cup, piston seal, piston boot, master cylinder piston kit, pipe or hose).
(4) Improperly adjusted shoe clearance	Adjust.
(5) Improper lining contact or worn lining	Correct or replace.

BRAKES

[T100] 4-4

Trouble and possible cause	Corrective action
4. Brake dragging or improper brake return	
(1) Insufficient pedal play	Adjust play.
(2) Improper master cylinder return	Clean or replace the cylinder.
(3) Clogged hydraulic system	Replace.
(4) Improper return or adjustment of parking brake	Correct or adjust.
(5) Weakened spring tension or breakage of shoe return spring	Replace the spring.
(6) Excessively narrow shoe clearance	Adjust the clearance.
(7) Improper disc caliper operation	Correct or replace.
(8) Improper adjusted wheel bearing	Adjust or replace.
5. Brake noise (1) (creak sound)	
(1) Hardened or deteriorated lining	Replace the shoe ASSY or pad.
(2) Worn lining	Replace the shoe ASSY or pad.
(3) Loosened back plate or the support installing bolts	Retighten.
(4) Loose wheel bearing	Retighten to normal tightening torque.
(5) Dirty drum or rotor	Clean the drum or rotor, or clean and replace the brake ASSY.
6. Brake noise (2) (hissing sound)	
(1) Worn lining	Replace the shoe ASSY or pad.
(2) Improper installed shoe or pad	Correct or replace the shoe ASSY or pad.
(3) Loose or bent drum or rotor	Retighten or replace.
7. Brake noise (3) (click sound)	
In the case of the disc brake.	
(1) Excessively worn pad or the support	Replace the pad or the support.
In the case of the drum brake.	
(1) Excessively worn shoe ridge.	Replace the back plate.
(2) Lack of oil on the shoe ridge surface and anchor	Add more grease.

2. Hill-Holder

Trouble and possible cause	Corrective action
1. Counterforce of clutch pedal is too strong	
(1) PHV cable is damaged or does not operate properly	Repair or replace.
(2) Lever of PHV is defective	Replace entire PHV ASSY.
(3) Clutch system is anomalous	Refer to "Clutch and pedal cable system".
2. Vehicle does not stop on uphill road of 3° or higher inclination	
(1) Front side of vehicle is lowered	Refer to "Suspension".
(2) PHV cable is broken	Replace.
(3) Play of clutch is excessive	Adjust.
(4) PHV cable is elongated	Adjust.
(5) Sealing of PHV is poor	Replace entire PHV ASSY.
3. Shock is felt when starting	
(1) Poor adjustment of starting performance	Adjust.
(2) When depressing the brake pedal strongly:	(The stronger brake pedal depressing force, the later hill holder releasing.)
(3) When starting on flat road after stopping reverse movement:	(Because hill holder is activated.)
4. Vehicle slips down when starting	
(1) PHV cable is elongated	Adjust.
(2) Clutch facing is worn out	Adjust or replace.
(3) Bracket (cable) or stay (PHV) is deformed	Repair or replace.
5. Vehicle cannot start after stoppage	
(1) Return spring is fatigued or broken	Replace.
(2) PHV lever won't return	Replace entire PHV ASSY.
(3) When intentionally depressing brake pedal strongly:	[When the brake pedal is depressed by a force of 1,177 N (120 kg, 265 lb) or more.]
6. Abnormal sound is generated upon releasing brake pedal when stopping	
Rotor and pad matched with each other due to inadequate depressing force to brake pedal	(Abnormal sound is not generated when depressing brake pedal a little stronger.)

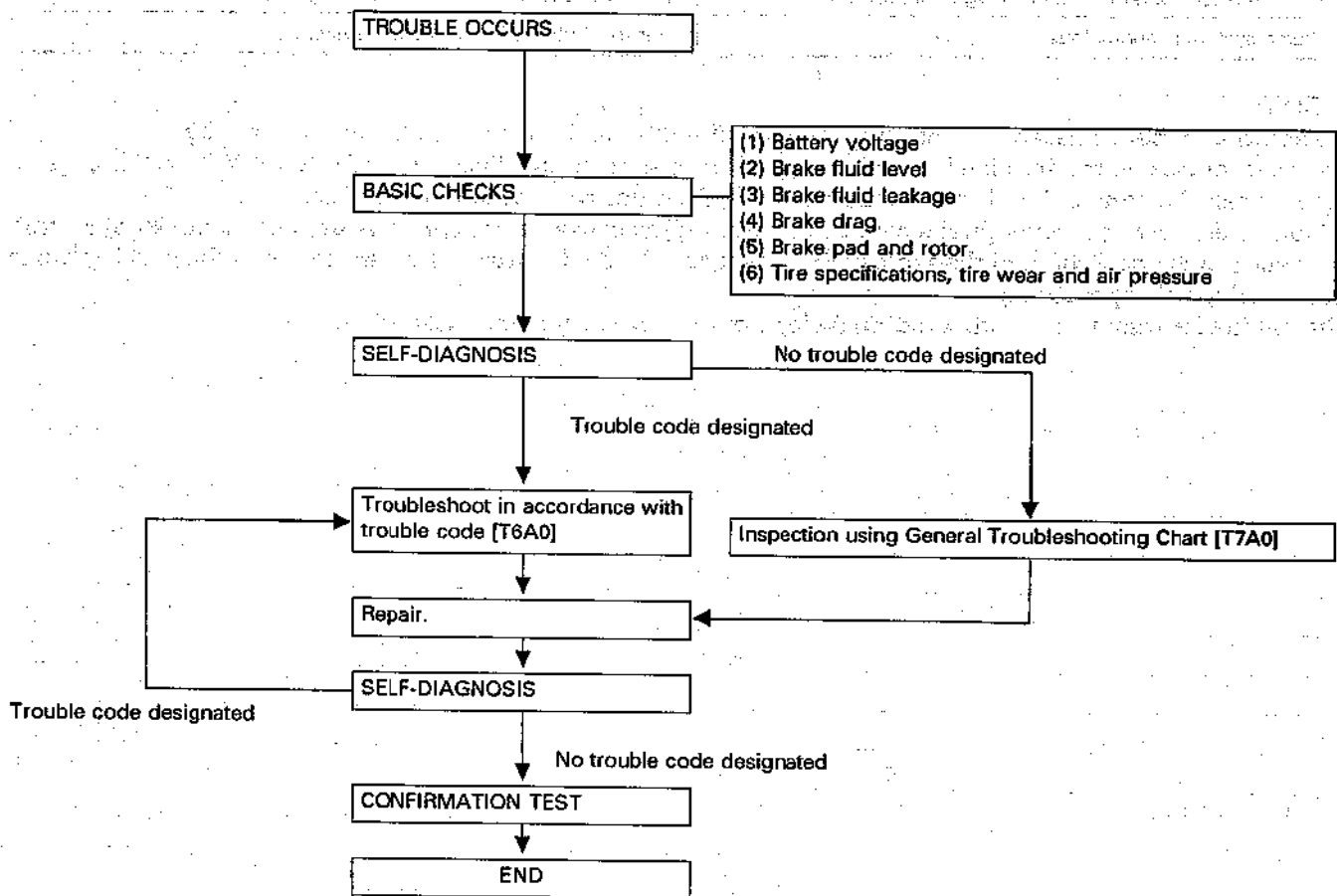
Trouble and possible cause	Corrective action
7. Abnormal sound is generated when operating clutch pedal	
(1) Grease is inadequate for the hook of return spring and sliding portion of PHV cable end	Apply grease.
(2) When releasing after maintaining high fluid pressure:	(Flowing sound of fluid when releasing high fluid pressure.)
(3) Clutch system is anomalous	Refer to "Clutch and pedal cable system".

CAUTION:

- a. Description in parentheses is a characteristic of hill-holder and does not indicate abnormality. Depressing force required for clutch pedal equipped to hill-holder specifications is 20 to 29 N (2 to 3 kg, 4 to 7 lb) larger than the conventional specifications, which does not constitute abnormality.
- b. When vehicle cannot travel (brake cannot be released) because return spring is broken, remove adjust nut, disconnect clutch and PHV, and then return PHV lever to release the brake. (Be sure to apply the parking brake before starting this operation.)
- c. The hill-holder may not be activated on a slope of an extremely small inclination.

3. Troubleshooting for ABS

A: BASIC TROUBLESHOOTING PROCEDURE



a. To check harness for broken wires or short-circuits, shake it while holding it or the connector.

b. When ABS warning lamp illuminates, read and record trouble code indicated by ECU's LED.

B: SELF-DIAGNOSIS

Conduct self-diagnosis after driving the vehicle at speeds greater than 30 km/h (19 MPH) for at least one minute. The vehicle must be stopped with the engine operating. When a problem is detected by self-diagnosis, the warning light in the instrument panel comes on.

Approximately 5 — 12 seconds after the warning light has come on, the problem detected by the ABS control

unit (located under the right front seat) is displayed by a trouble code in terms of "the number of LED's blinks."

a. Both the warning light and the LED remain activated unless the ignition key is turned OFF. With the ignition key turned OFF, the contents of the problem stored in the memory are reset.

b. Only one trouble code is displayed at a time. When a multiple of problems occur, only the first problem detected is displayed.

c. If the LED does not activate (though the warning light is ON), the power supply may be inoperative.

C: LIST OF TROUBLE CODES**1. TROUBLE CODES**

Trouble code	Contents of diagnosis	
0 [LED OFF]	Improper power line voltage or faulty harness	
1	Broken or shorted solenoid valve circuit(s) in hydraulic unit	Left front wheel control
2		Right front wheel control
3		Right rear wheel control
4		Left rear wheel control
5	Faulty ABS sensor	Left front wheel speed
6		Right front wheel speed
7		Right rear wheel speed
8		Left rear wheel speed
9	Faulty motor and/or motor relay or broken or shorted harness circuit	
10	Faulty valve relay or broken or shorted harness circuit Faulty valve relay or broken or shorted harness, or interrupted ABS (causing brakes to function as a conventional brake system)	
16	Faulty ABS control unit or G sensor or broken or shorted harness circuit Faulty ABS control unit or G sensor or broken or shorted harness, or malfunctioning system or line unidentified by vehicle speed sensor fail-safe function.	

2. HOW TO READ TROUBLE CODE:

The LED in the ABS control unit flashes the code corresponding to the faulty part.

Trouble codes are displayed by the number of LED blinks.

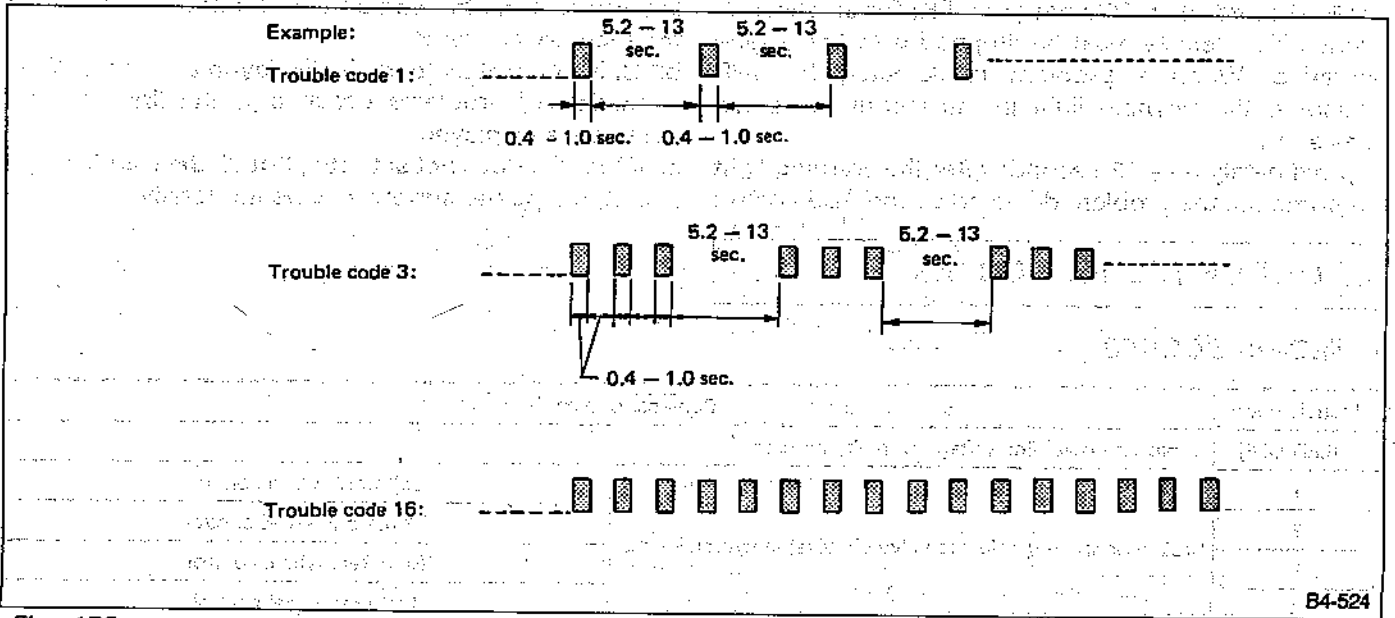


Fig. 175

4. ABS Control Unit I/O Signal

A: I/O SIGNAL VOLTAGE

18	17	16	15	14	13	12	11	10	9	8	7	6	5	4	3	2	1
35	34	33	32	31	30	29	28	27	26	25	24	23	22	21	20	19	

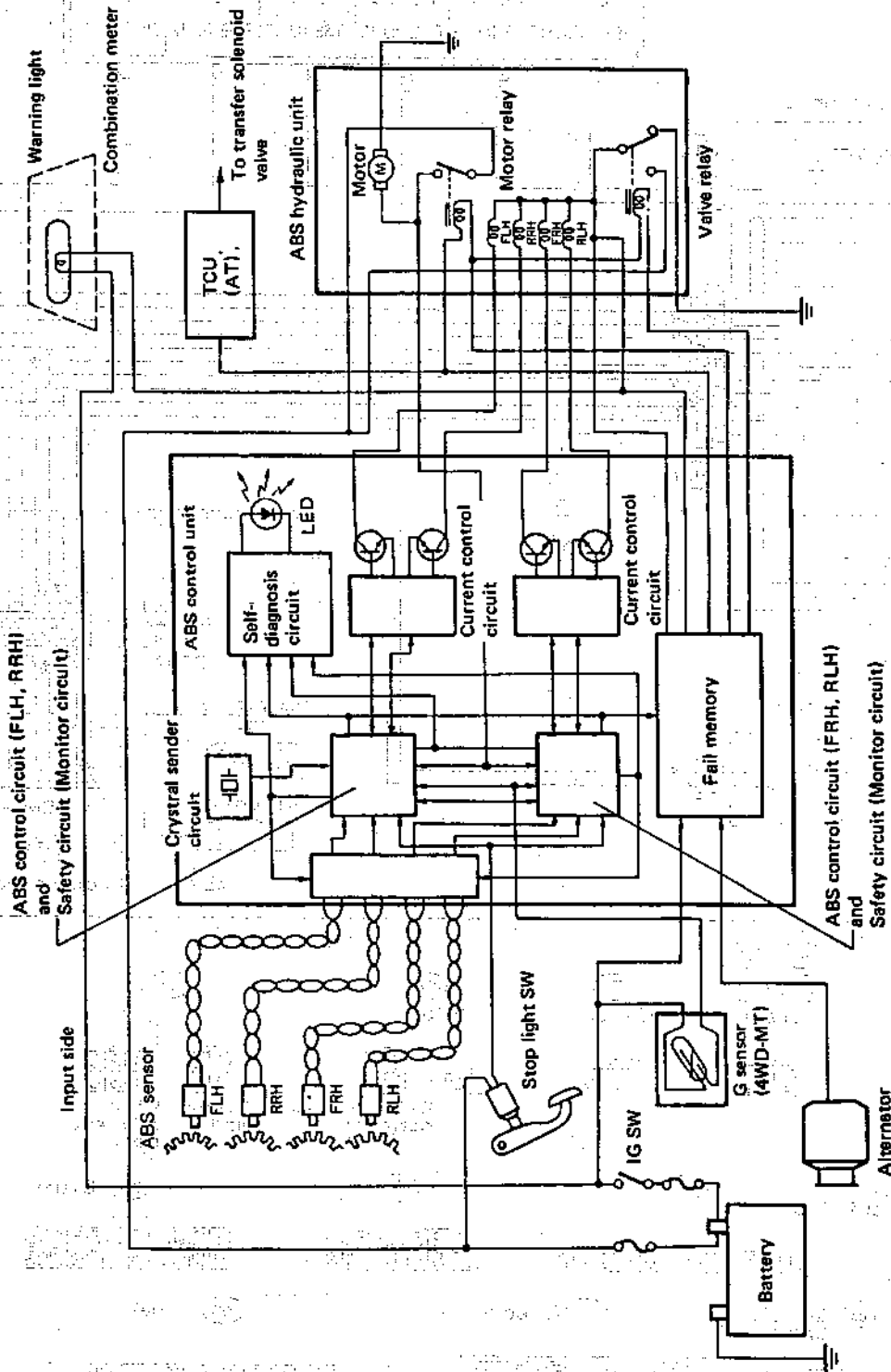
TO (P12)

B4-525

Fig. 176

Contents		Terminal No.	With engine idling	Input/output signals		
				Measured value	Measuring conditions	
ABS sensors	Left front wheel	22	0V	200 — 300 mV (AC range)	<ul style="list-style-type: none"> No. 22 — No. 4 Vehicle speed 2.75 km/h (1.7 MPH) 	
	GND	4				
	Right front wheel	11	0V	200 — 300 mV (AC range)	<ul style="list-style-type: none"> No. 11 — No. 21 Vehicle speed 2.75 km/h (1.7 MPH) 	
	GND	21				
	Left rear wheel	7	0V	200 — 300 mV (AC range)	<ul style="list-style-type: none"> No. 7 — No. 9 Vehicle speed 2.75 km/h (1.7 MPH) 	
	GND	9				
	Right rear wheel	24	0V	200 — 300 mV (AC range)	<ul style="list-style-type: none"> No. 24 — No. 26 Vehicle speed 2.75 km/h (1.7 MPH) 	
	GND	26				
G sensor		16	13 — 14V	0V		
Stop light switch		25	0V	13 — 14V	When brake pedal is depressed.	
Motor monitoring		14	0V	13 — 14V	When motor operates.	
Valve power-supply monitoring		32	13 — 14V	13 — 14V	—	
Hydraulic unit	Solenoid	Left front wheel	2	13 — 14V	0V	When solenoid is energized to produce output.
		Right front wheel	35	13 — 14V	0V	
		Left rear wheel	18	13 — 14V	0V	
		Right rear wheel	19	13 — 14V	0V	
	Valve relay coil		27	0V	0V	—
	Motor relay coil		28	13 — 14V	0V	When motor operates to produce output
Warning light		29	0V	13 — 14V	Ignition switch ON (Engine OFF)	
Power supply	Alternator	15	13 — 14V	1.7V	Ignition switch ON (Engine OFF)	
	Battery	1	13 — 14V	13 — 14V	—	
	Relay coil (valve, motor, etc.)	17	13 — 14V	13 — 14V	—	
Grounding line		10	0V	0V	—	
		20	0V	0V	—	
		34	0V	0V	—	

B: I/O SIGNAL DIAGRAM



5. Diagram of ABS

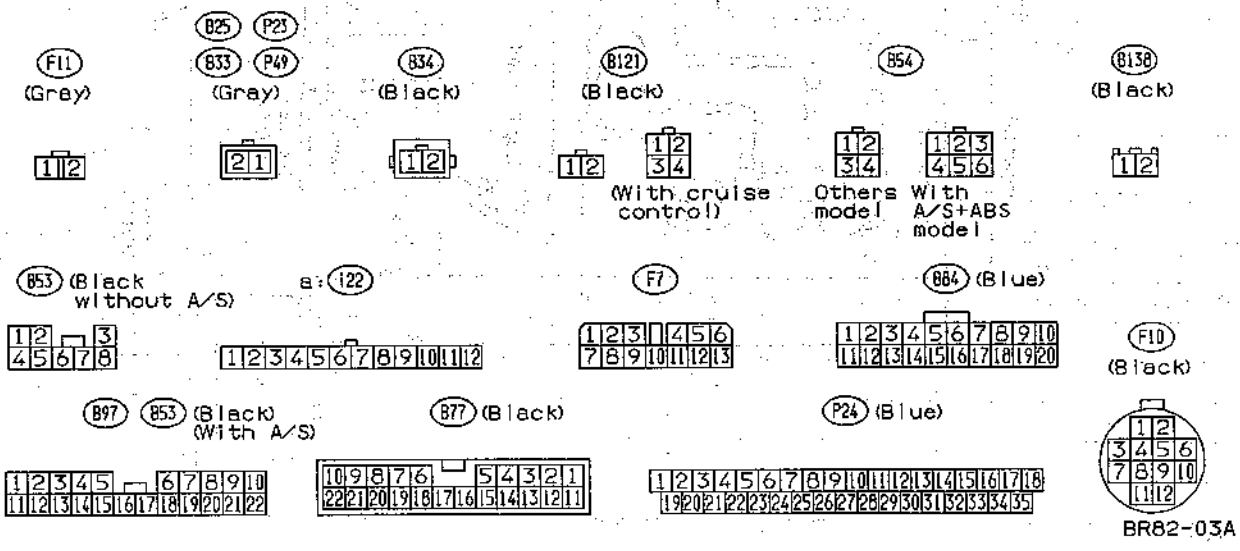
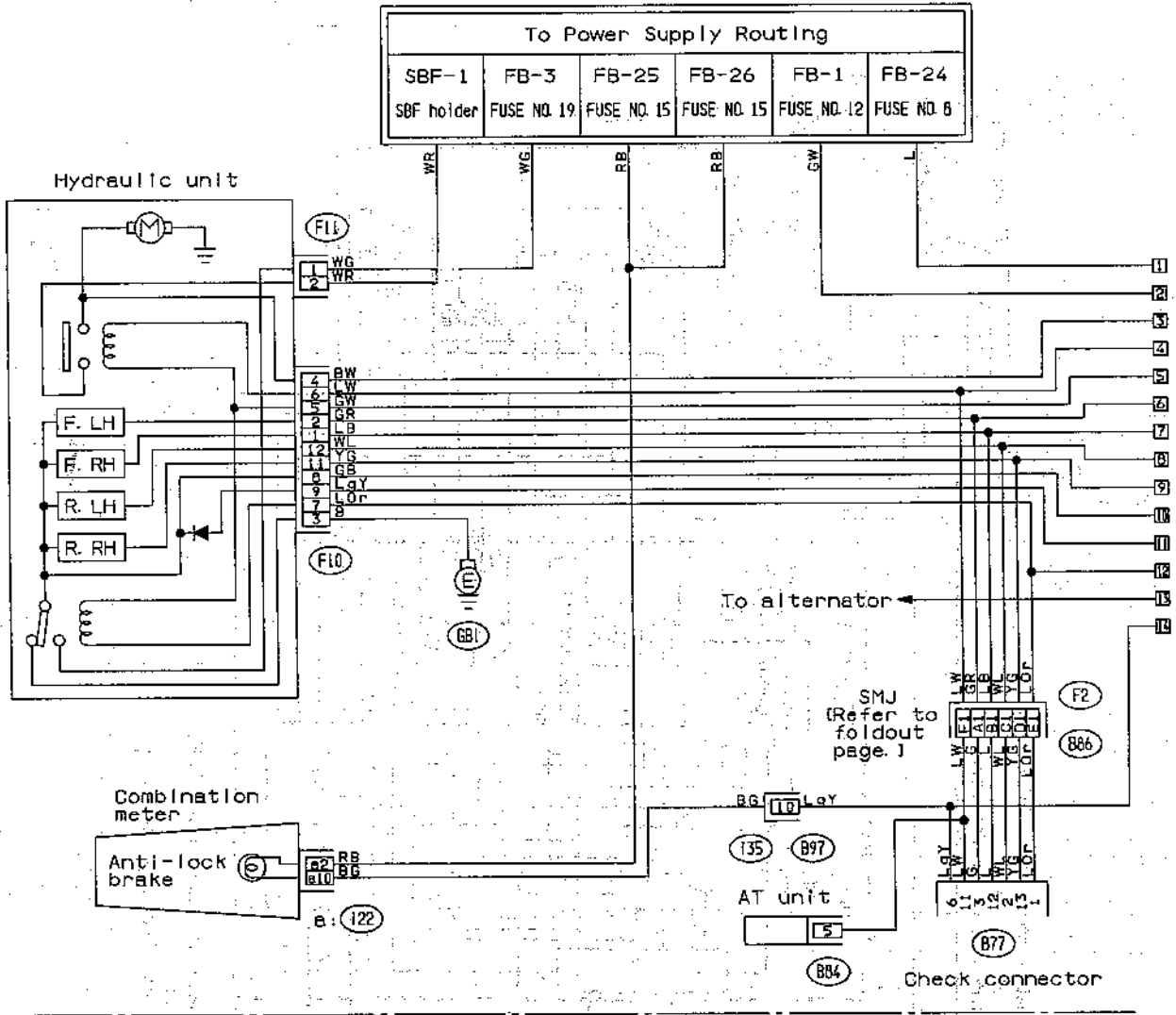
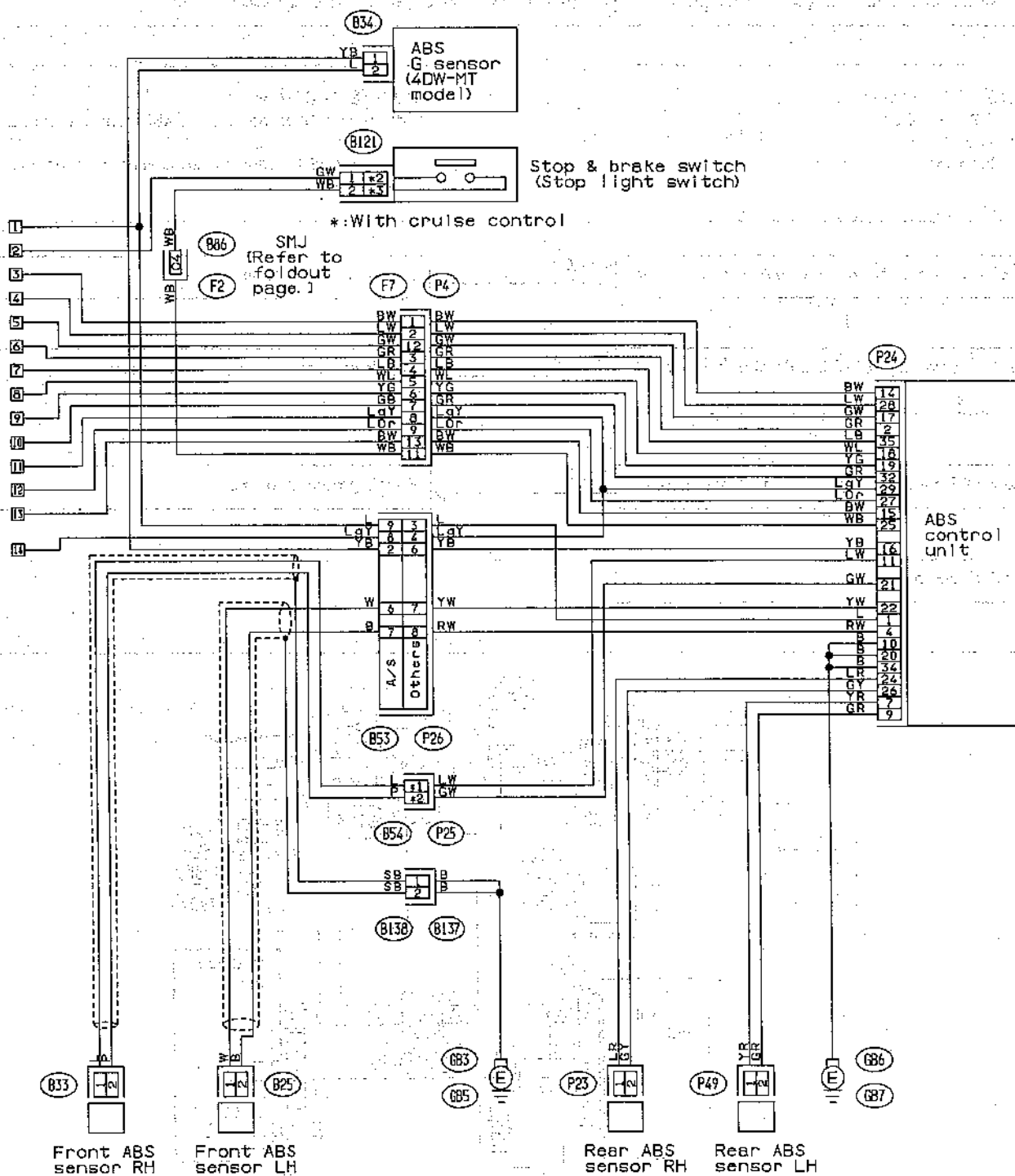


Fig. 178

BRAKES

[T500] 4-4



	*1	*2
With A/S+ABS model	2	6
Others model	1	4

BR82-03B

6. Troubleshooting Chart with Trouble Code

A: TROUBLE CODE (0) — Improper power line voltage or faulty harness

CONTENTS OF DIAGNOSIS:

- Faulty ABS control unit
- Faulty harness
- Faulty alternator

TROUBLE SYMPTOM:

- Warning light comes on but ABS control unit LED does not.
- Normal ABS function resumes although ignition switch remains ON.

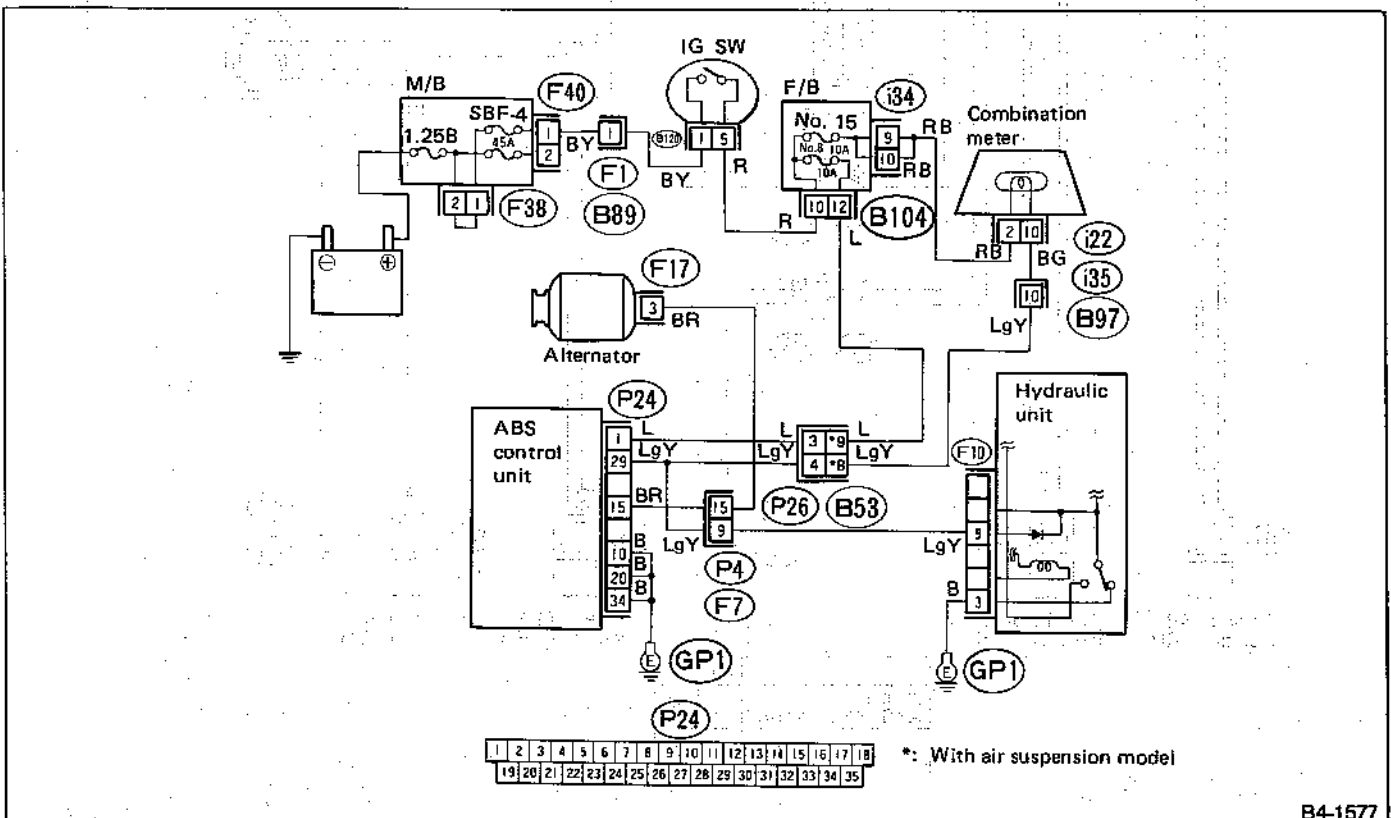
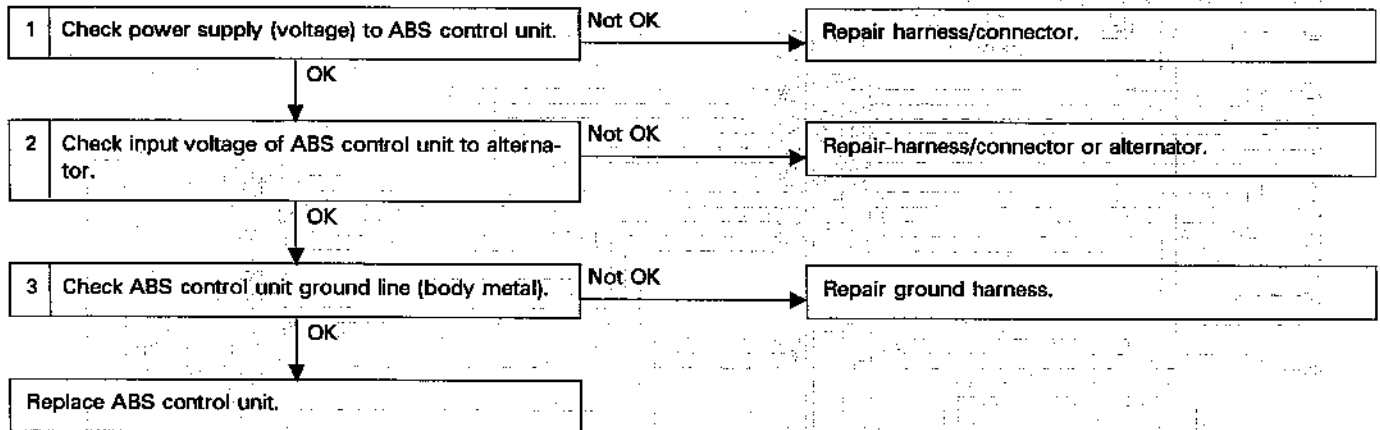


Fig. 179

B4-1577

1. CHECK POWER SUPPLY (VOLTAGE) TO ABS CONTROL UNIT

- 1) Turn ignition switch OFF.
- 2) Disconnect connector from ABS control unit.
- 3) Disassemble connector.
 - a) While pushing portion ①, disconnect connector.
 - b) Remove screw from portion ②.
 - c) Move rubber boot ③ back (toward harness).
 - d) Slide cover ④ in direction shown by arrow and remove.

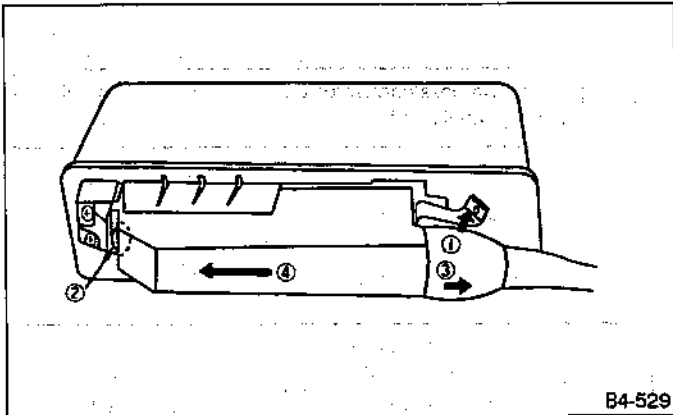


Fig. 180

- 4) Turn ignition switch ON.
- 5) Measure voltage between ABS control unit connector and body.

Connector & terminal / Specified Voltage:
 (P24) No. 1 — Body / 10 — 12 V

2. CHECK INPUT VOLTAGE OF ABS CONTROL UNIT TO ALTERNATOR

- 1) Start the engine.
- 2) Measure voltage between ABS control unit connector and body.

Connector & terminal / Specified Voltage:
 (P24) No. 15 — Body / Approx. 13.5 V

3. CHECK ABS CONTROL UNIT GROUND SYSTEM

- 1) Turn ignition switch OFF.
- 2) Connect connector to ABS control unit.
- 3) Turn ignition switch ON.
- 4) Measure voltage between ABS control unit terminal and body.

Terminal / Specified Voltage:
 (P24) No. 20 — Body / 0 V

B: TROUBLE CODE (1 — 4) — Faulty solenoid valve circuit(s) in hydraulic unit

CONTENTS OF DIAGNOSIS:

- Faulty harness/connector in hydraulic unit
- Faulty solenoid valve in hydraulic unit

TROUBLE SYMPTOM:

- ABS does not operate.

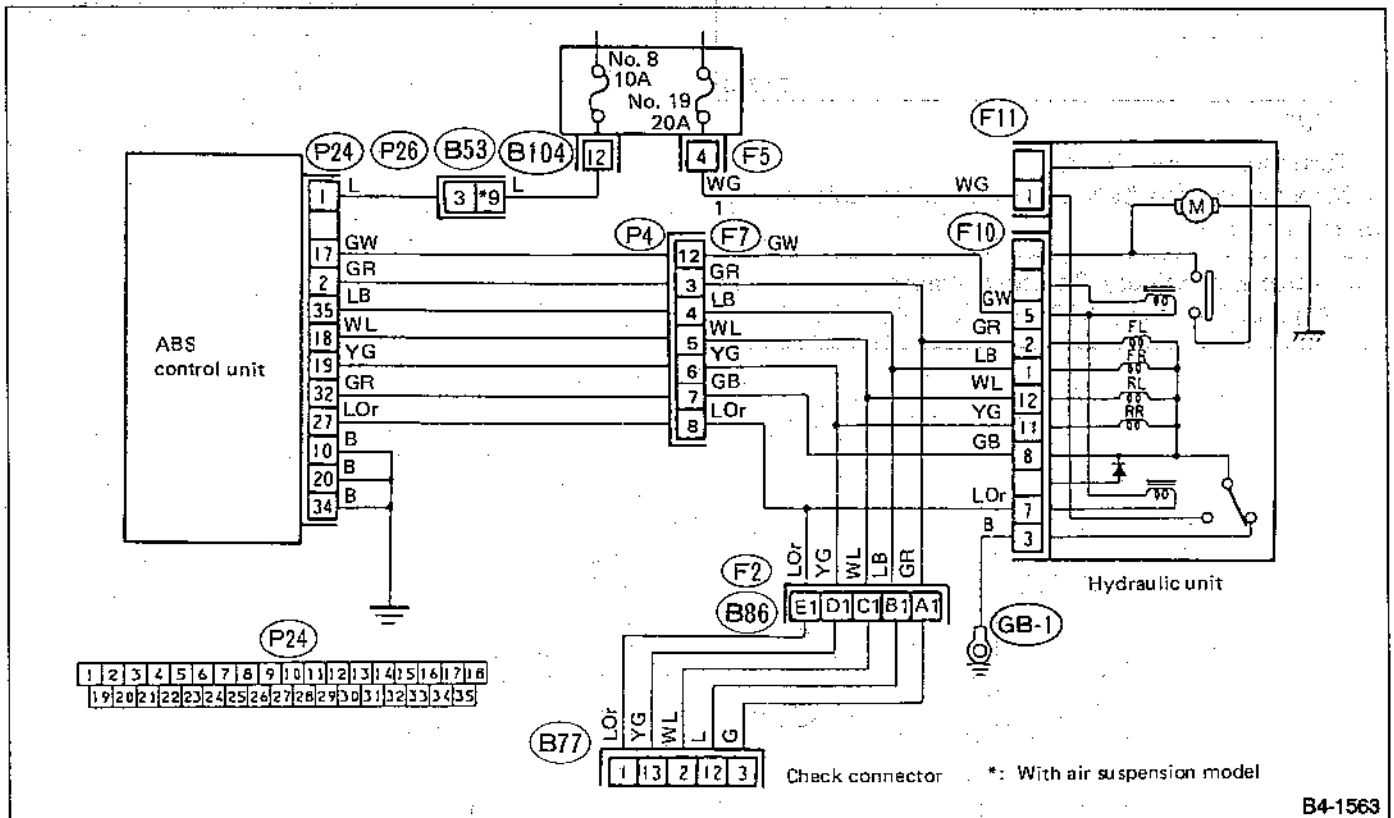
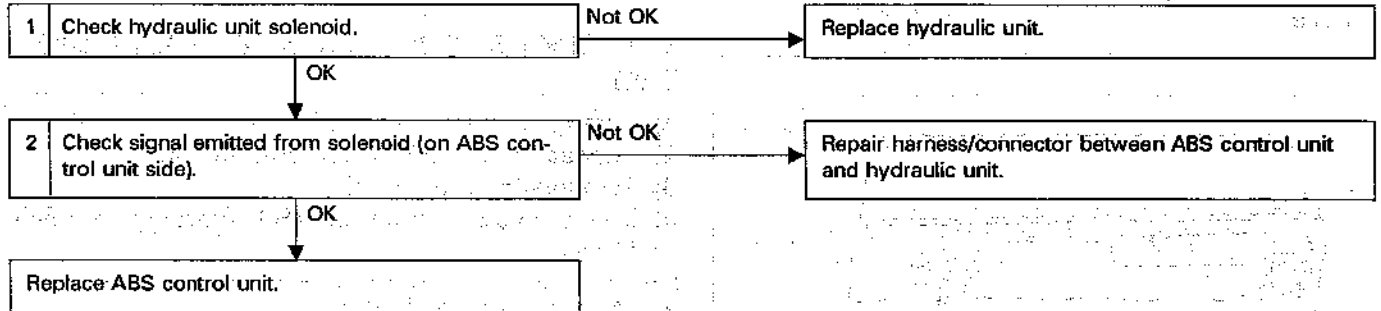


Fig. 181

B4-1563

1. CHECK HYDRAULIC UNIT SOLENOID

- 1) Turn ignition switch ON.
- 2) Ground check-connector terminal, and check solenoid valve for operation (sound which indicates proper operation).

Each time solenoid activates, system circuit is interrupted. To check again, first turn ignition switch OFF and then ON.

TROUBLE CODE / Connector & Terminal:

- 1 / (B77) No. 3 — Body
- 2 / (B77) No. 12 — Body
- 3 / (B77) No. 13 — Body
- 4 / (B77) No. 2 — Body

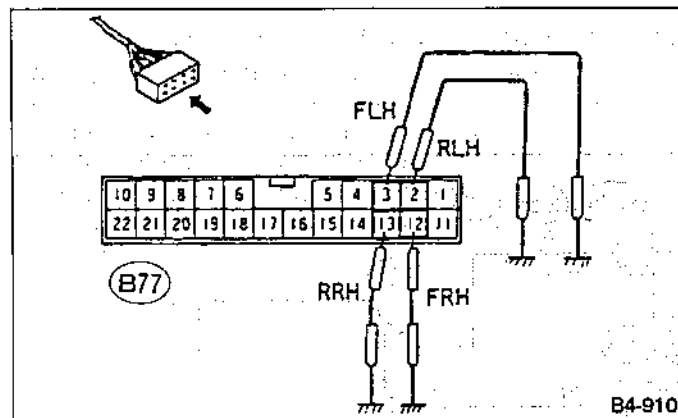


Fig. 182

2. CHECK SOLENOID (ON ABS CONTROL UNIT SIDE)

- 1) Turn ignition switch ON.
- 2) Attach circuit tester's positive probe to terminal (corresponding with solenoid) and ground probe to ground and measure voltage between terminal and ground.

Each time solenoid activates, system circuit is interrupted. To check again, first turn ignition switch OFF and then ON.

TROUBLE CODE / Connector & Terminal:

- 1 / (P24) No. 2 — Body
- 2 / (P24) No. 35 — Body
- 3 / (P24) No. 19 — Body
- 4 / (P24) No. 18 — Body

Specified Voltage: 0 V (solenoid in operation)

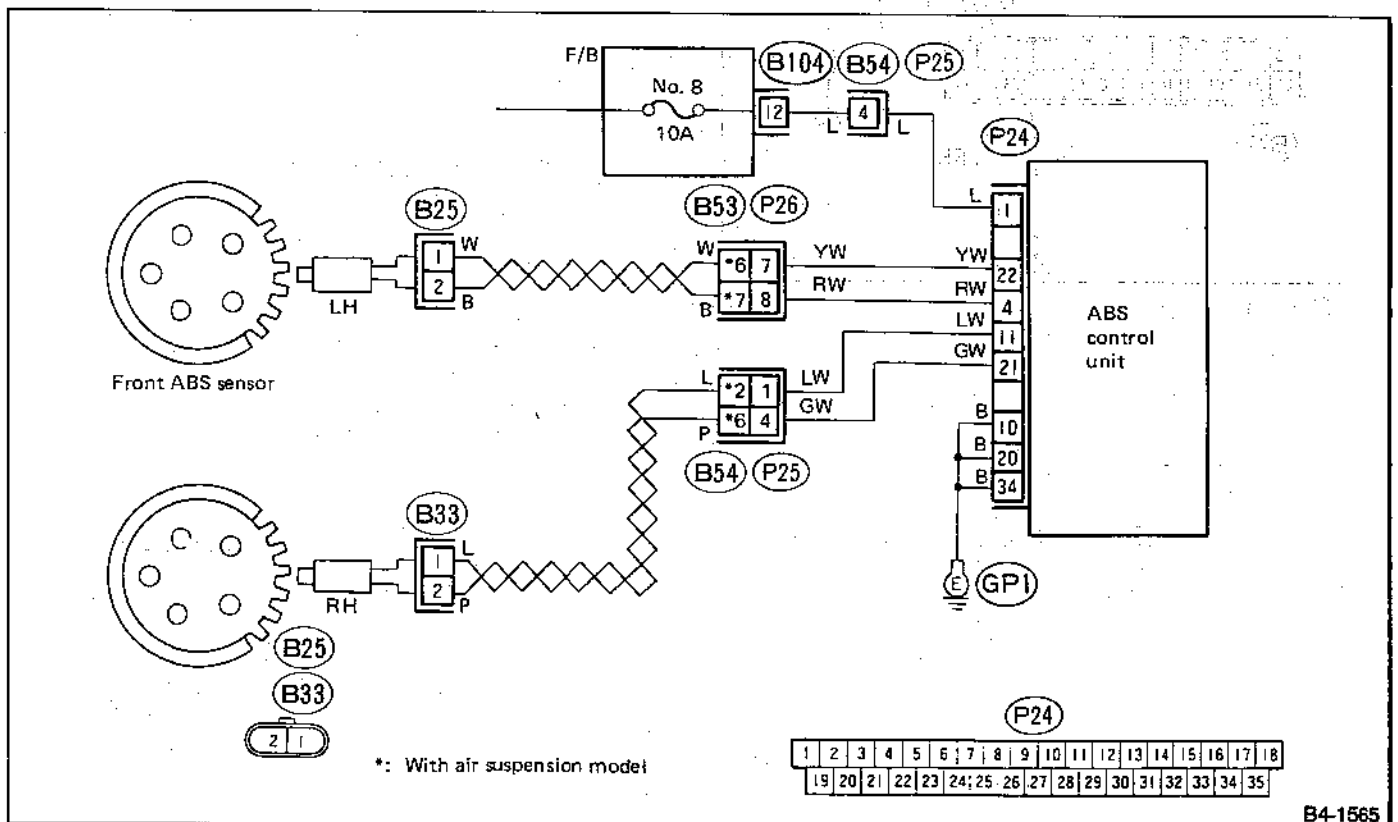
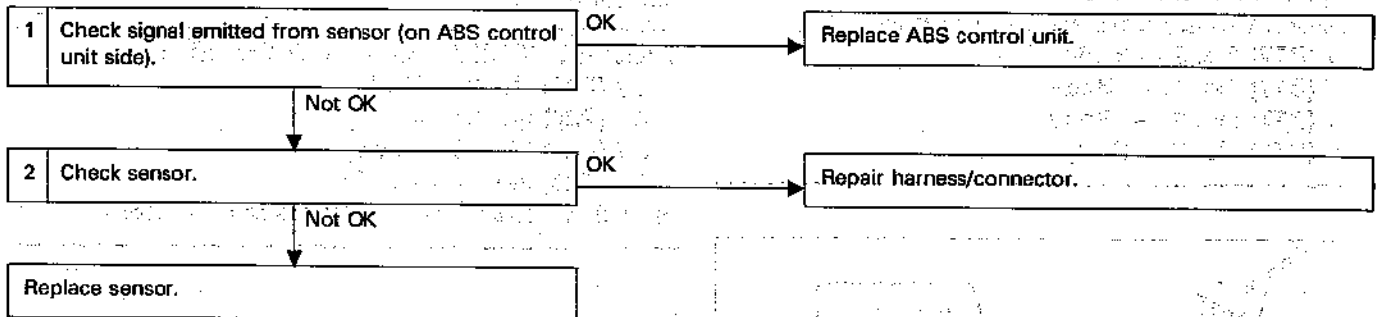
C: TROUBLE CODE (5 and 6) — Faulty front ABS sensor

CONTENTS OF DIAGNOSIS:

- Faulty front ABS sensor or harness
- Faulty ABS control unit

TROUBLE SYMPTOM:

- ABS does not operate.



B4-1565

Fig. 183

1. CHECK SIGNAL EMITTED FROM SENSOR (ON ABS CONTROL UNIT SIDE)

- 1) Disconnect connector from ABS control unit. (Refer to No. T6A1)
- 2) Raise all four wheels off ground.
- 3) Measure voltage between ABS control unit terminals using a digital circuit tester (set in "AC" range) according to trouble code.

TROUBLE CODE / Connector & Terminal:

5 / (P24) No. 4 — No. 22

6 / (P24) No. 11 — No. 21

Specified Voltage:

200 — 300 mV (at "creep" speed of AT model)

- 4) Disconnect ABS control unit connector, and measure resistance between sensor and body.

Connector & terminal / Specified Resistance:

(P24) No. 22 — Body / 1 M Ω min.

(P24) No. 21 — Body / 1 M Ω min.

2. CHECK SENSOR

- 1) Disconnect sensor connector.
- 2) Measure resistance between sensor terminals.

TROUBLE CODE / Connector & Terminal:

5 / Sensor LH No. 1 — No. 2

6 / Sensor RH No. 1 — No. 2

Specified Resistance: 0.8 — 1.3 k Ω

- 3) Measure resistance between sensor connector terminal and body.

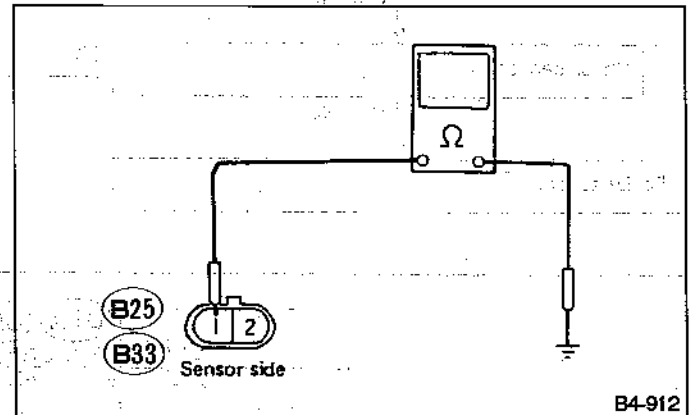


Fig. 184

Connector & terminal / Specified Resistance:

(B25) No. 1 — Body / 1 M Ω min.

(B33) No. 1 — Body / 1 M Ω min.

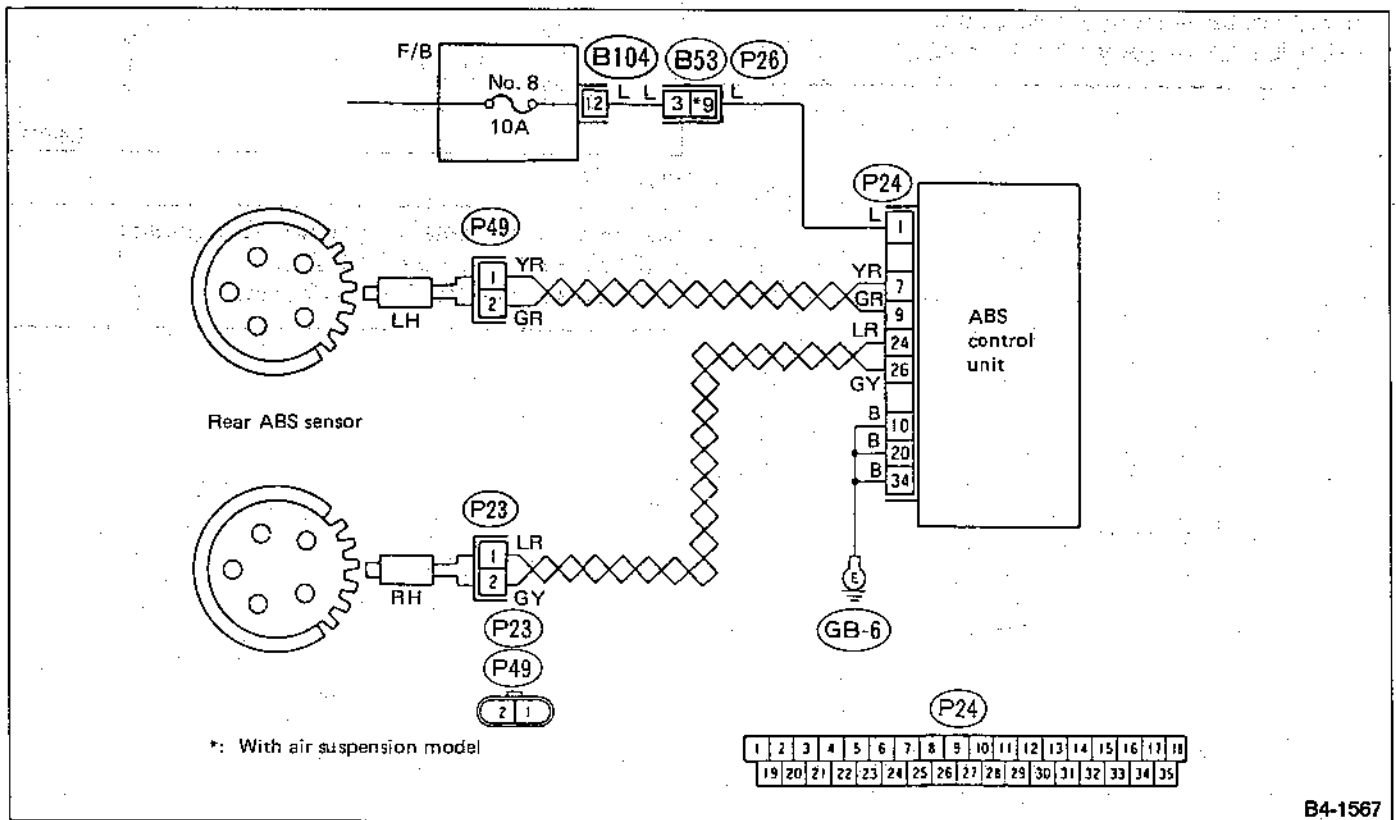
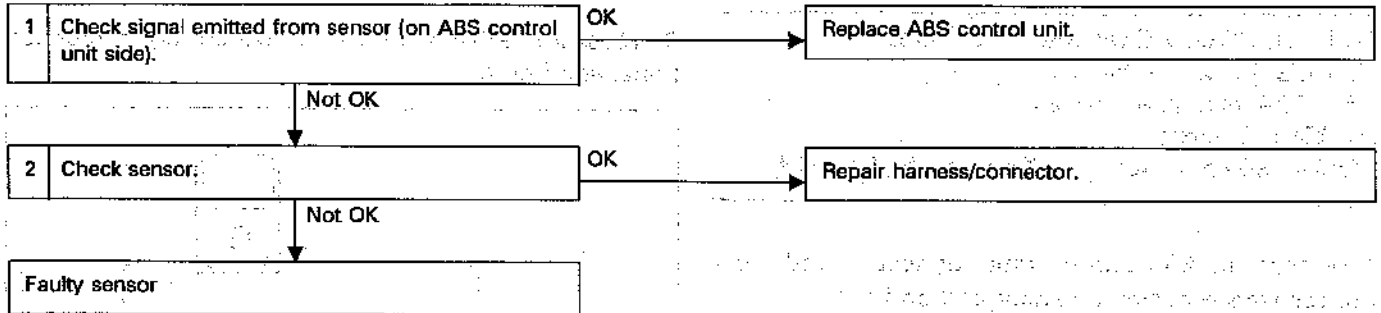
D: TROUBLE CODE (7 and 8) — Faulty rear ABS sensor

CONTENTS OF DIAGNOSIS:

- Faulty rear ABS sensor or harness
- Faulty ABS control unit

TROUBLE SYMPTOMS:

- ABS does not operate.
- Rear wheels only are occasionally controlled by ABS.



B4-1567

Fig. 185

1. CHECK INPUT SIGNAL OF SENSOR TO ABS CONTROL UNIT

- 1) Disconnect connector from ABS control unit. (Refer to No. T6A1)
- 2) Raise wheels off ground.
- 3) Measure voltage between ABS control unit terminals using a digital circuit tester, (Set in "AC" range) according to trouble code.

TROUBLE CODE / Connector & Terminal:

7 / (P24) No. 24 — No. 26

8 / (P24) No. 7 — No. 9

Specified Voltage:

200 — 300 mV (at "creep" speed of AT model)

- 4) Disconnect ABS control unit connector and measure resistance between sensor and body.

Connector & Terminal / Specified Resistance:

(P24) No. 26 — Body / 1 M Ω min.

(P24) No. 9 — Body / 1 M Ω min.

2. CHECK SENSOR

- 1) Disconnect sensor connector.
- 2) Measure resistance between sensor terminals.

TROUBLE CODE / Connector & Terminal:

7 / Sensor RH No. 1 — No. 2

8 / Sensor LH No. 1 — No. 2

Specified Voltage: 0.8 — 1.3 k Ω

- 3) Measure resistance between sensor connector terminal and body.

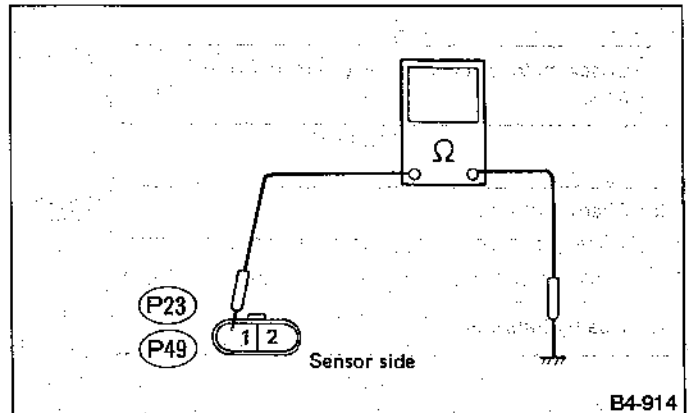


Fig. 186

Connector & Terminal / Specified Resistance:

(P23) No. 1 — Body / 1 M Ω min.

(P49) No. 1 — Body / 1 M Ω min.

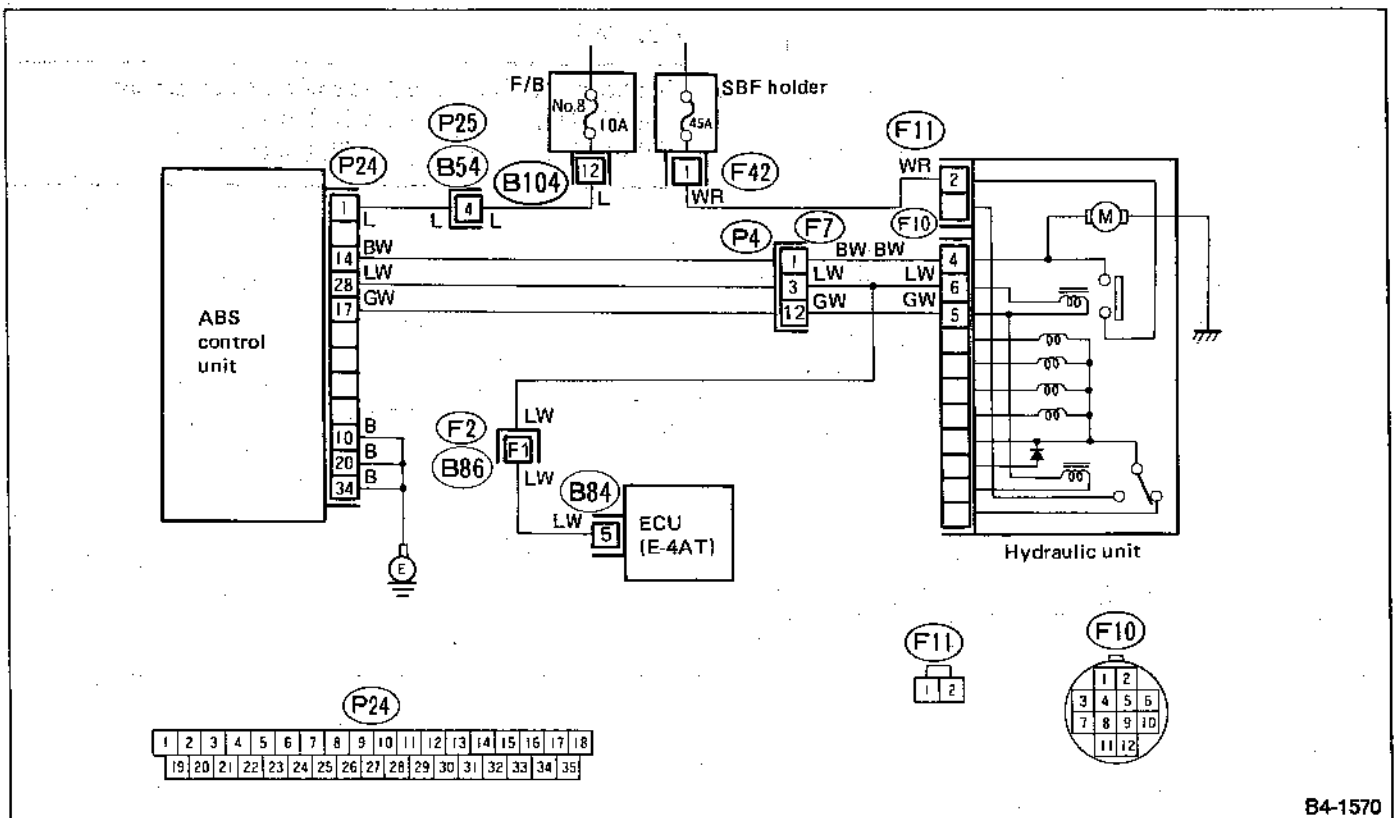
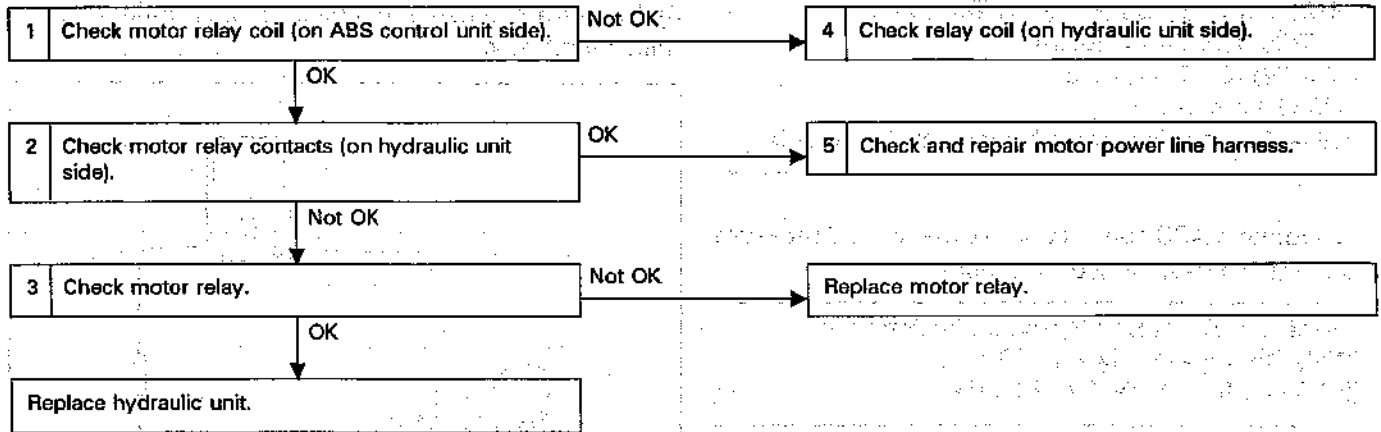
E: TROUBLE CODE (9) — Faulty hydraulic motor or motor relay

CONTENTS OF DIAGNOSIS:

- Faulty main power supply
- Faulty hydraulic motor or motor relay built into hydraulic unit

TROUBLE SYMPTOM:

- ABS does not operate.



84-1570

Fig. 187

1. CHECK RELAY COIL (ON ABS CONTROL UNIT SIDE)

- 1) Turn ignition switch OFF.
- 2) Disconnect ABS control unit connector.
- 3) Disassemble ABS control unit connector.
- 4) Measure resistance between ABS control unit terminals.

Connector & terminal / Specified Resistance:
(P22) No. 17 — No. 28 / 45 — 55 Ω

2. CHECK MOTOR RELAY CONTACTS (ON HYDRAULIC UNIT SIDE)

- 1) Disconnect connectors from hydraulic unit.
- 2) Measure resistance between hydraulic unit terminals.

Terminal / Specified Resistance:
(To F11) No. 2 — (To F10) No. 4 / 1 M Ω min.

3. CHECK MOTOR RELAY

- 1) Remove motor relay.
- 2) Attach circuit tester probes to terminals, as shown in Figure.

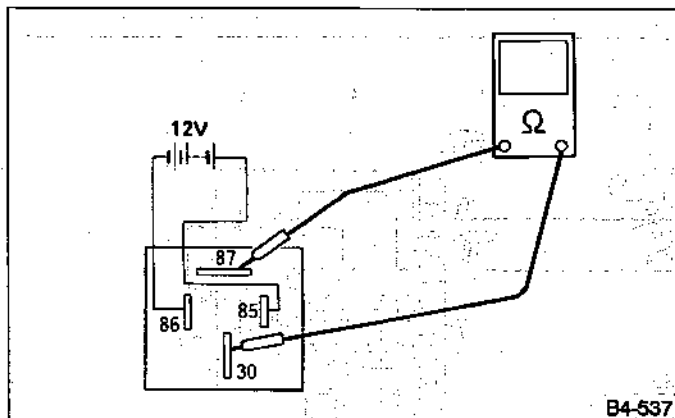


Fig. 188

- 3) Measure resistance between terminals.

Terminal / Specified Resistance:
No. 30 — 87 / 0 Ω (when 12 volts applied)
No. 30 — 87 / 1 M Ω min. (when no voltage is applied)

4. CHECK RELAY COIL (ON HYDRAULIC UNIT SIDE)

- 1) Disconnect connector from hydraulic unit.
- 2) Measure resistance between hydraulic unit terminals.

Terminal / Specified Resistance:
No. 5 — No. 6 / 45 — 55 Ω

When resistance checks out "Not OK", check relay as a single unit.

- If resistance checks out "OK", replace hydraulic unit.
- If "Not OK", repair harness connector between ABS control unit and hydraulic unit.

- 3) Disconnect connectors from ABS control unit and hydraulic unit. Measure resistance between connectors, and between each connector and body.

Connector & terminal / Specified Resistance:
(F10) No. 6 — (P24) No. 28 / 0 Ω
(F10) No. 5 — (P24) No. 17 / 0 Ω
(F10) No. 6 — Body / 1 M Ω min
(F10) No. 4 — Body / 1 M Ω min

5. CHECK AND REPAIR MOTOR POWER HARNESS

- 1) Turn ignition switch ON.
- 2) Measure voltage between hydraulic unit connector and body.

Connector & terminal / Specified Voltage:
(F11) No. 2 — Body / 10 — 12 V

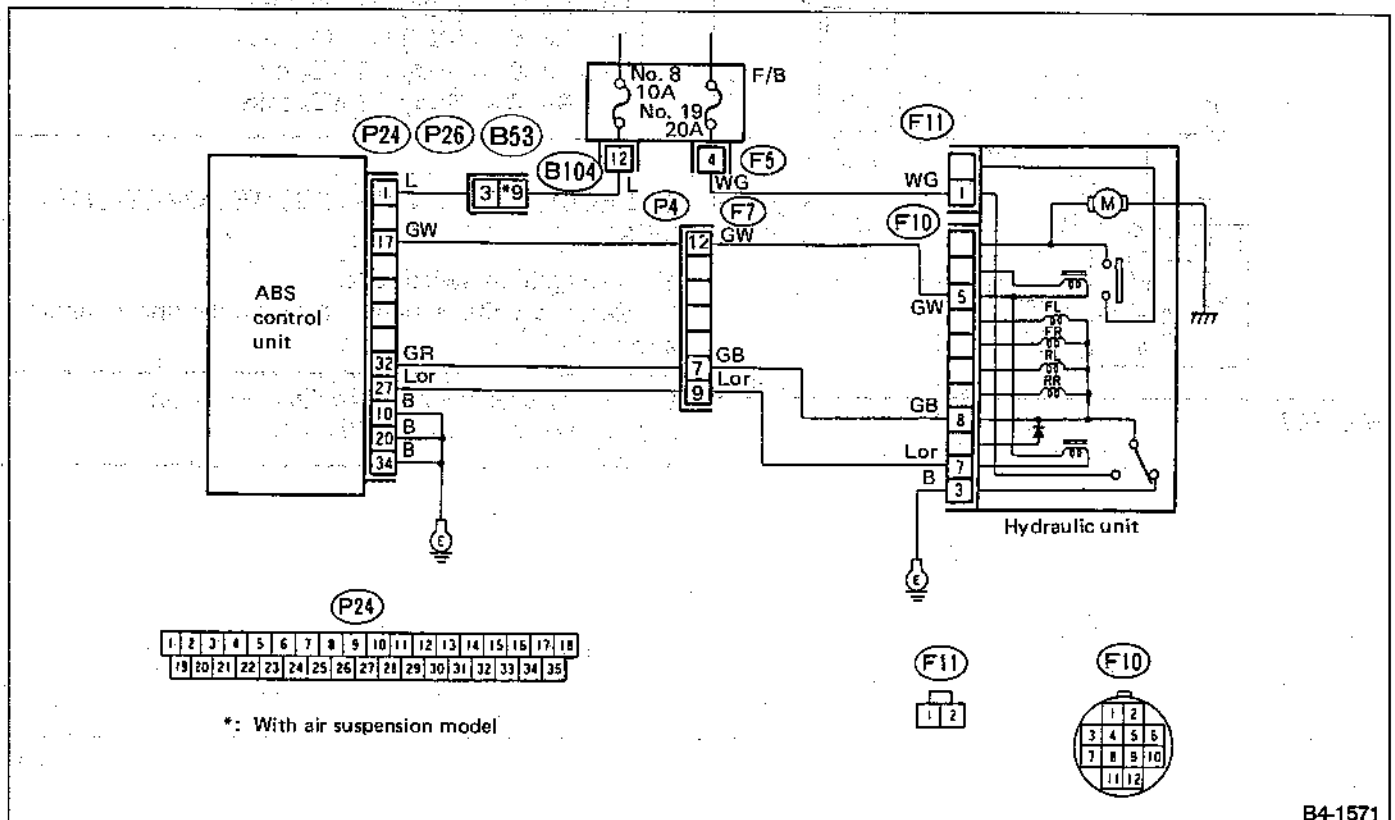
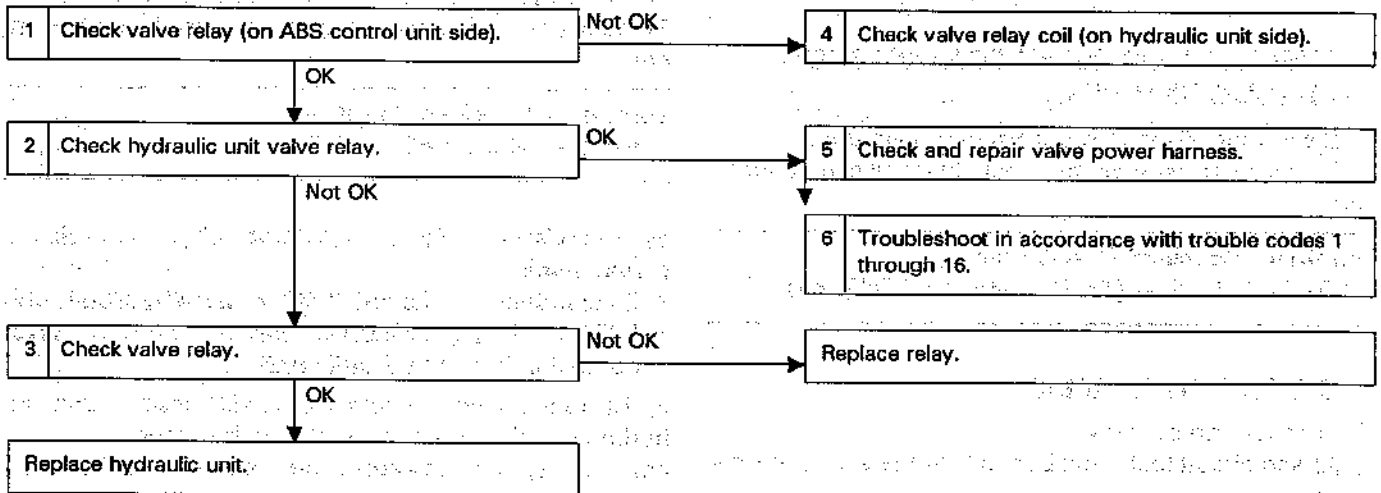
F: TROUBLE CODE (10) — Faulty valve relay or interrupted system operation (caused by symptoms other than those indicated at left.)

CONTENTS OF DIAGNOSIS:

- Faulty main power supply
- Faulty hydraulic unit valve relay
- Interference with other system

TROUBLE SYMPTOM:

- ABS does not operate.



B4-1571

Fig. 189

1. CHECK VALVE RELAY COIL (ON ABS CONTROL UNIT SIDE)

- 1) Turn ignition switch OFF.
- 2) Disconnect ABS control unit connector.
- 3) Disassemble connector. (Refer to No. T6A1)
- 4) Measure resistance between ABS control unit terminals.

Connector & terminal / Specified Resistance:
(P24) No. 17 — No. 27 / 80 — 90 Ω

2. CHECK HYDRAULIC UNIT VALVE RELAY

- 1) Disconnect connector from hydraulic unit.
- 2) Measure resistance between hydraulic unit terminals.

Terminal / Specified Resistance:
(To F11) No. 1 — (To F10) No. 8 / 1 M Ω min.

3. CHECK VALVE RELAY AS A SINGLE UNIT

- 1) Remove valve relay.
- 2) Attach circuit tester probes to terminals, as shown in Figure.

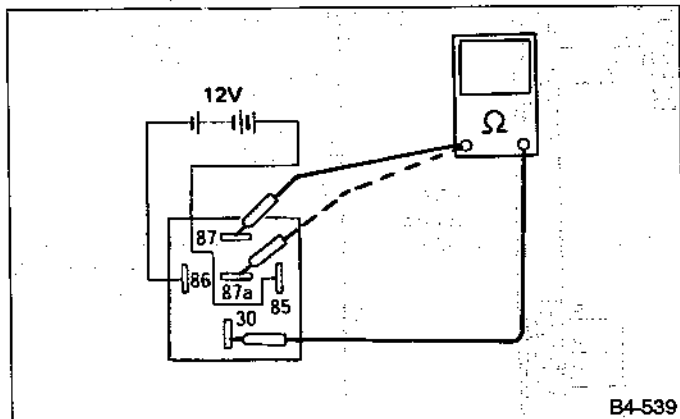


Fig. 190

- 3) Measure resistance between respective terminals.

Terminal / Specified Resistance:
No. 87 — 30 / 0 Ω (when 12 volts applied)
No. 87 — 30 / 1 M Ω (when no voltage is applied)
No. 87a — 30 / 1 M Ω (when 12 volts applied)
No. 87a — 30 / 0 Ω (when no voltage is applied)

4. CHECK HYDRAULIC UNIT VALVE RELAY COIL

- 1) Disconnect connector from hydraulic unit.
- 2) Measure resistance between hydraulic unit terminals.

Terminal / Specified Resistance:
(To F10) No. 5 — No. 7 / 80 — 90 Ω

When resistance checks out "Not OK", check relay as a single unit.

- w3) Disconnect connectors from ABS control unit and hydraulic unit. Measure resistance between connectors.

Connector & terminal / Specified Resistance:
(F10) No. 5 — (P12) No. 17 / 0 Ω
(F10) No. 7 — (P12) No. 27 / 0 Ω
(F10) No. 5 — Body / 1 M Ω min.
(F10) No. 7 — Body / 1 M Ω min.

If resistance checks out "OK", replace hydraulic unit; if "Not OK", repair harness/connector between ABS control unit and hydraulic unit.

5. CHECK AND REPAIR POWER HARNESS

- 1) Turn ignition switch ON.
- 2) Measure resistance between hydraulic unit connector and body.

Connector & terminal / Specified Voltage:
(F11) No. 1 / 10 — 12 V

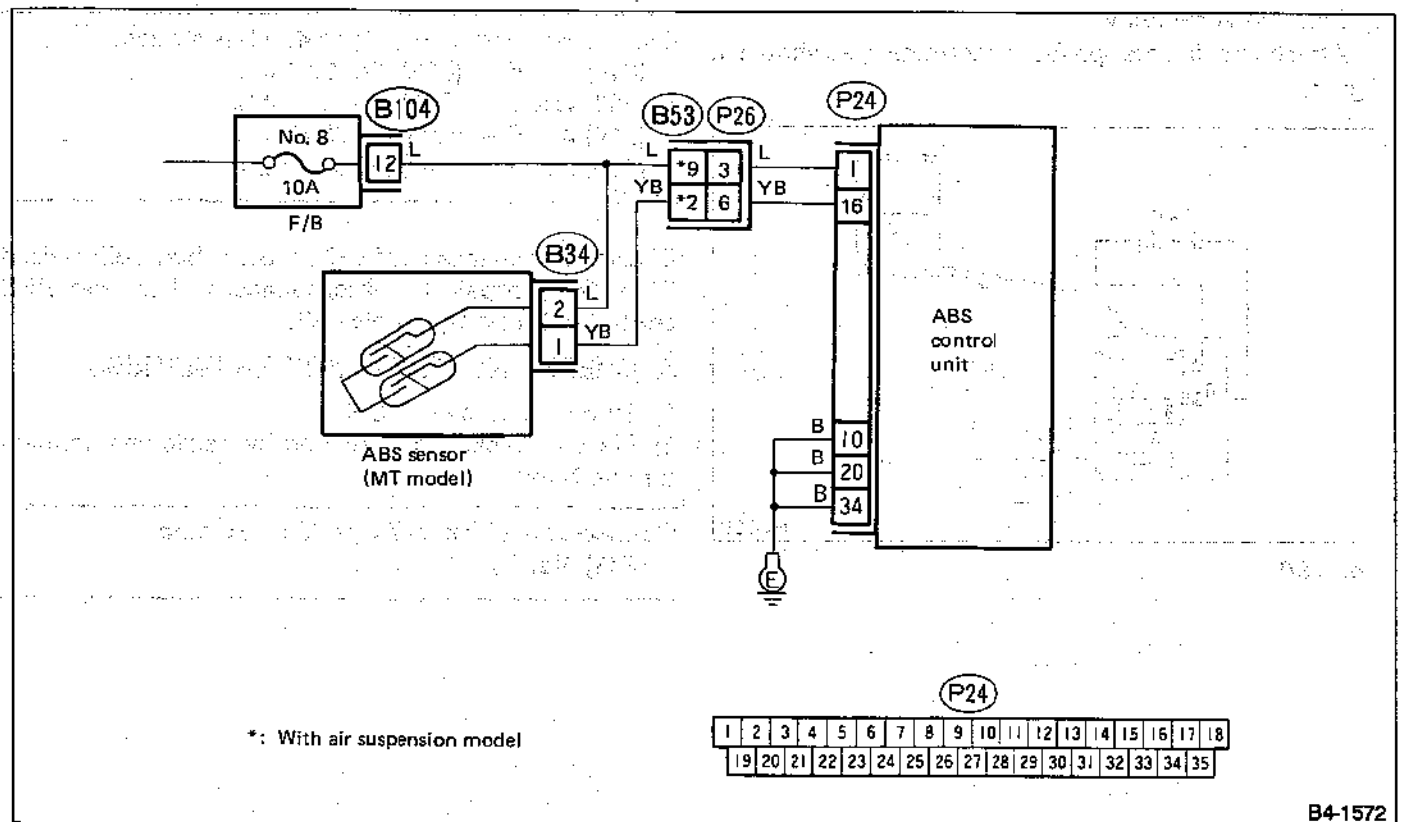
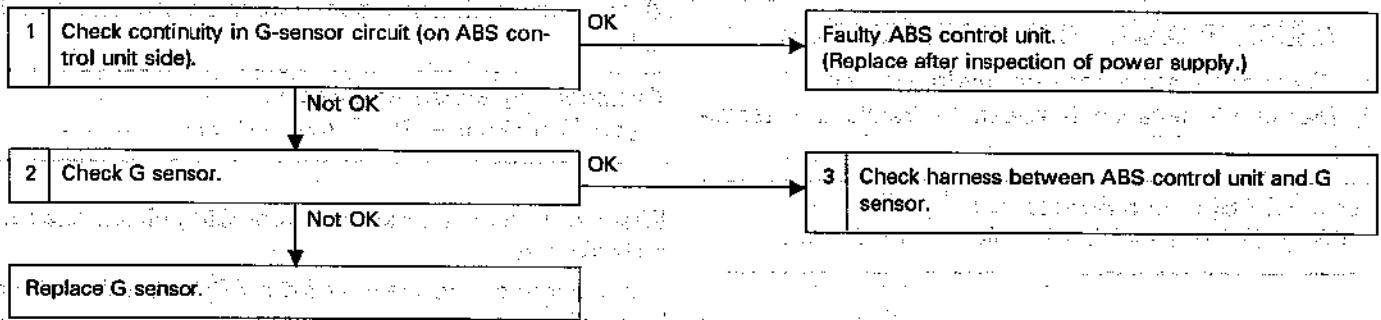
G: TROUBLE CODE (16) — Faulty ABS control unit or G sensor (4WD, MT model)

CONTENTS OF DIAGNOSIS:

- Faulty ABS control unit
- Faulty power supply to ABS control unit or faulty ground system
- Faulty G sensor
- Faulty G-sensor harness and connector

TROUBLE SYMPTOMS:

- ABS control unit does not operate.
- ABS activates faster than specifications when braking on high "μ" (dry asphalt) road.
- Warning light comes on and trouble code "16" is displayed approximately 20 seconds after vehicle starts.



B4-1572

Fig. 191

1. CHECK CONTINUITY IN G SENSOR CIRCUIT (ON ABS CONTROL UNIT SIDE)

- 1) Position vehicle on a flat surface.
- 2) Disconnect connector from ABS control unit.
- 3) Disassemble connector.
- 4) Measure resistance between ABS control unit connector terminals.

Connector & terminal / Specified Resistance:
 (P24) No. 1 — No. 16 / 550 — 670 Ω

2. CHECK G SENSOR

- 1) Disconnect G-sensor connector.
- 2) Measure resistance between G-sensor terminals. (Ensure that G sensor is horizontal during measurement.)

Specified Resistance:
 550 — 670 Ω

3. CHECK AND REPAIR HARNESS BETWEEN ABS CONTROL UNIT AND G SENSOR

- 1) Turn ignition switch ON.
- 2) Connect G-sensor connector.
- 3) Measure voltage between connector and body.

Connector & terminal / Specified Voltage:
 (B34) No. 2 — Body / 10 — 12 V
 (P24) No. 16 — Body / 10 — 12 V

When resistance checks out "OK", replace ABS control unit.

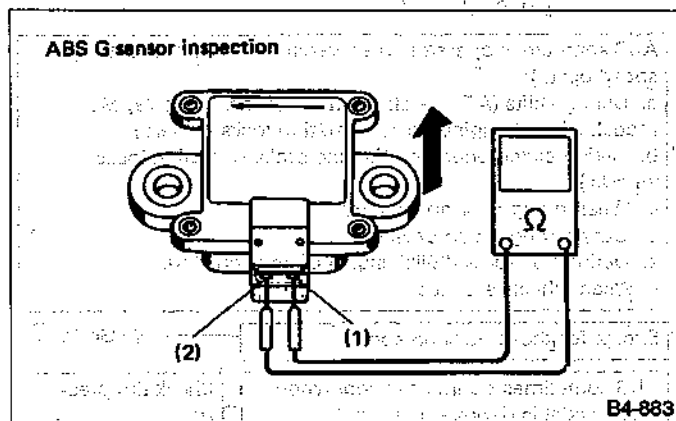


Fig. 192

7. General Troubleshooting Chart

A: VIBRATING PEDAL AND NOISE

Brake pedal vibrates and noise occurs.

Depress brake pedal abruptly to check if such problems occur while ABS is in operation.

When do problems occur?

Normal

When engine starts

Before vehicle attains initial 10 km/h (6 MPH) speed immediately after engine starts

Only when vehicle is being driven

Brake pedal is released.

Brake pedal is depressed.

Check using self-diagnosis system according to trouble code.

Do problems stop within 5 seconds?

YES

Normal

NO
Go to ①

ABS sometimes operates when variations in wheel rotating speed occur:

- a. During shifts (AT model: Band brake locks wheels; MT model: Abrupt engine brake operation locks wheels.)
- b. During clutch operation (Engine brake operation locks wheels.)
- c. When riding over an obstacle
- d. During rough-road driving
- e. During "U" turns ("Slip" signal often is emitted.)
- f. When wheels are stuck

Except for those outlined above

Go to ①

ABS sometimes operates except when brake pedal is depressed abruptly:

- a. Low "μ" roads
- b. "U" turns during high-speed operations
- c. During rough-road driving
- d. When tire chains are installed
- e. Use of improper tires
- f. Excessive free play of wheels and associated parts

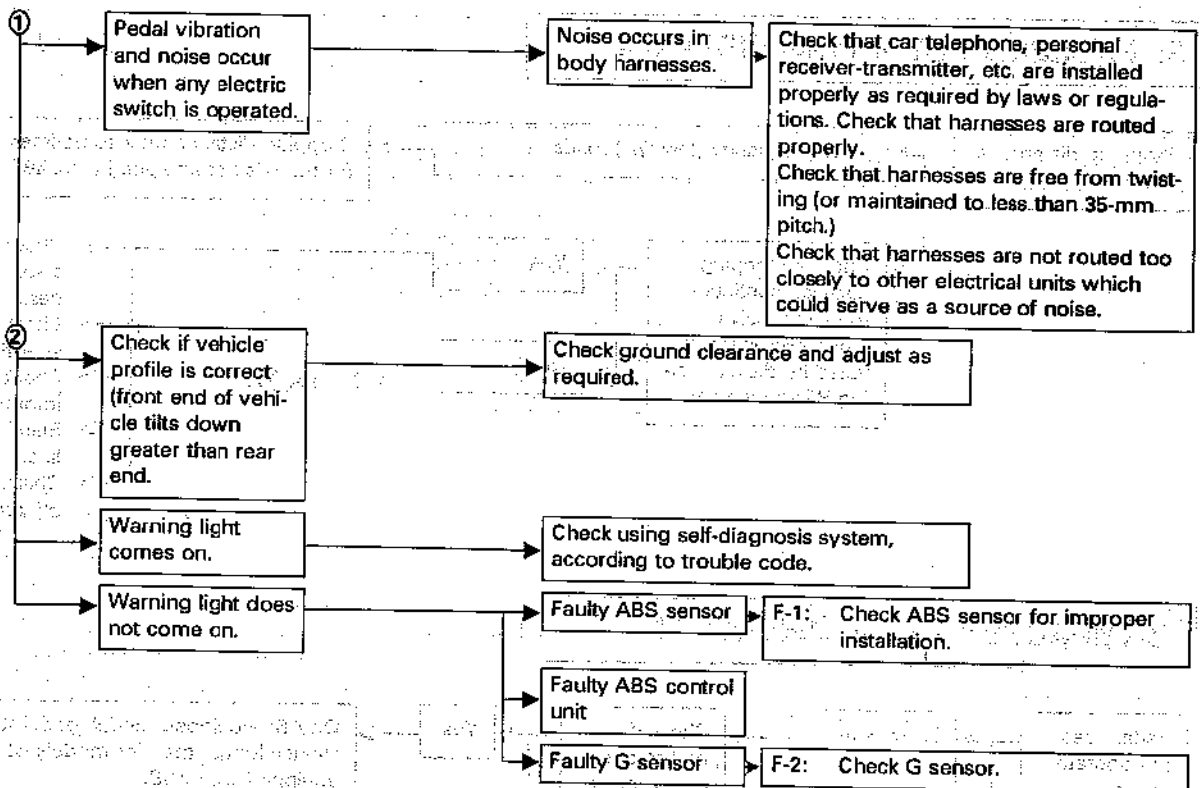
Check tire pressure. (Premature wear may occur if tires other than those specified are used.)

- a. Use specified tires.
- b. Adjust tire pressure evenly.
- c. Use of an "emergency" tire
- d. Check wheels and associated parts if excessive free play is noted.

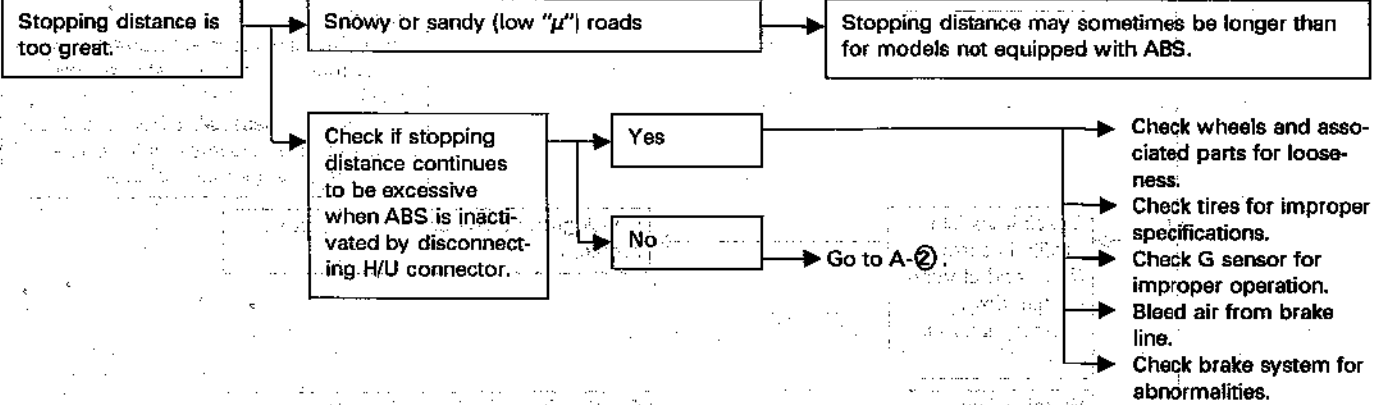
Except for those outlined above

Go to ①

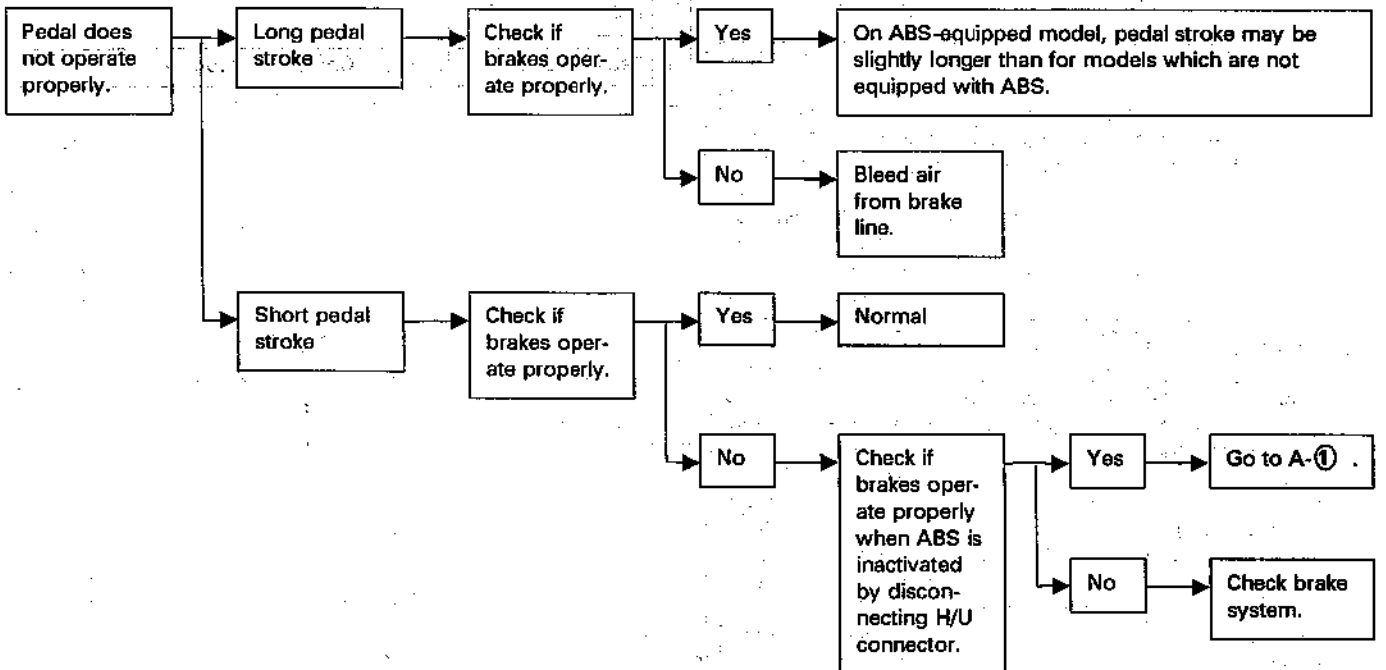
①



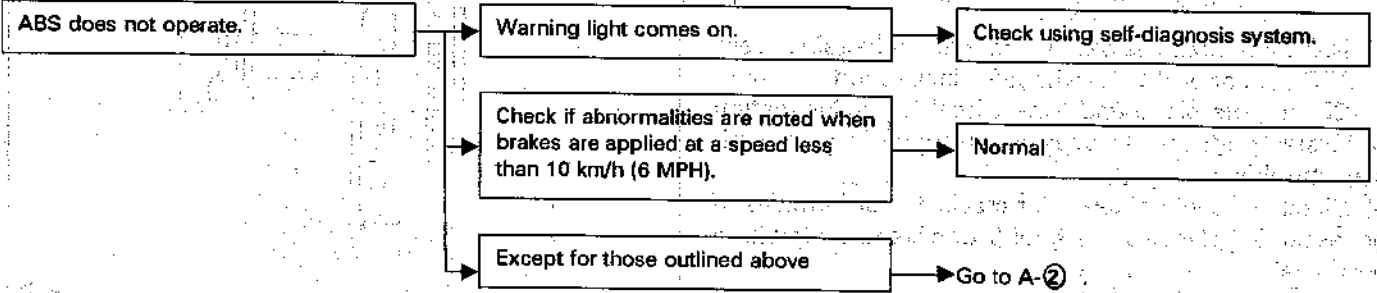
B: EXCESSIVE STOPPING DISTANCE



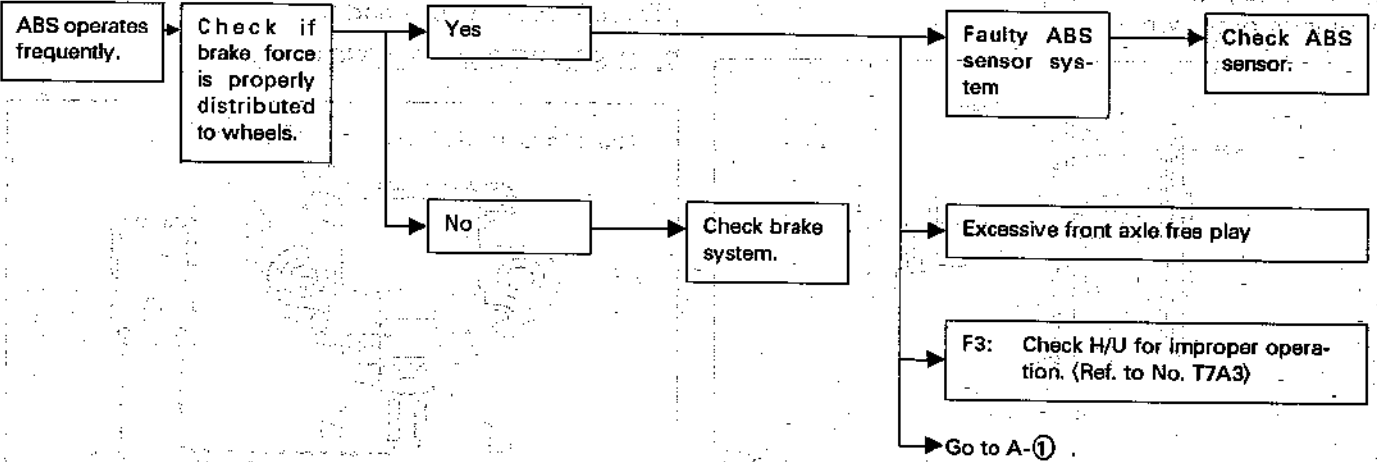
C: IMPROPER PEDAL OPERATION



D: ABS INOPERATIVE



E: FREQUENT ABS OPERATION



F: INSPECTION OF COMPONENTS

1. ABS SENSOR INSTALLATION

- 1) Dismount brake as outlined in manual to gain access to ABS sensor and tone wheel for inspection.
- 2) Check pole piece and tone wheel for accumulation of foreign particles. If necessary, remove foreign particles and clean.
- 3) Check tone wheel teeth for cracks for deformities. If necessary, replace tone wheel (No. of teeth: 44) with a new one.
- 4) Check tone wheel for looseness.

Tightening torque:

10 — 16 N•m (1 — 1.6 kg-m, 7 — 12 ft-lb)

- 5) Measure tone wheel-to-pole piece gap over entire perimeter of the wheel.

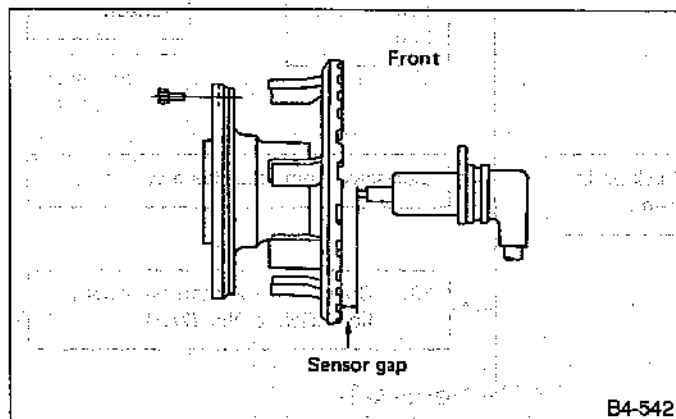


Fig. 193

Specifications	Front wheel	Rear wheel
	0.9 — 1.4 mm (0.035 — 0.055 in)	0.7 — 1.2 mm (0.028 — 0.047 in)

If measurements check out "Not OK", adjust the gap using spacers (Part No. 26755AA000). If spacers cannot correct the gap, replace worn sensor or worn tone wheel.

- 6) Check hub runout.

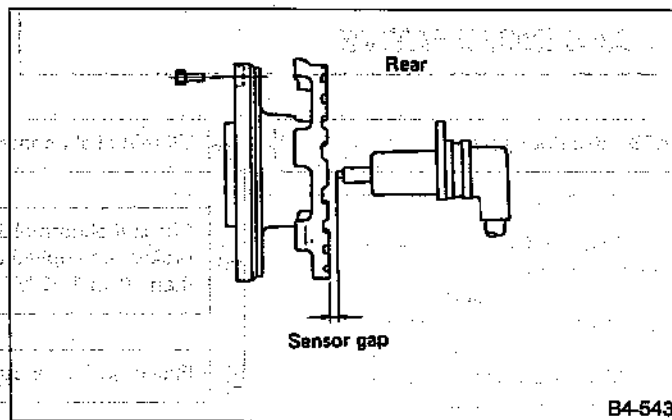


Fig. 194

Specifications	0.05 mm (0.0020 in)
----------------	---------------------

- 7) For inspection procedures of sensors, refer to "Trouble Codes 5, 6, 7 and 8".

2. G SENSOR INSPECTION

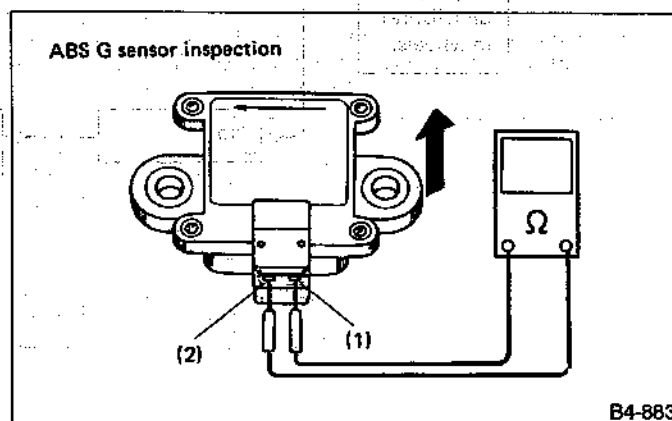


Fig. 195

- 1) Remove G sensor.
- 2) Check continuity between G-sensor terminals (1) and (2).
- 3) Tilt G sensor down in vehicle's advancing direction.

Specifications	Horizontal position	When tilted forward greater than 14 — 21.3°
	Continuity exists. (550 — 670 Ω)	Continuity does not exist. 550 — 670 Ω

3. HYDRAULIC UNIT INSPECTION

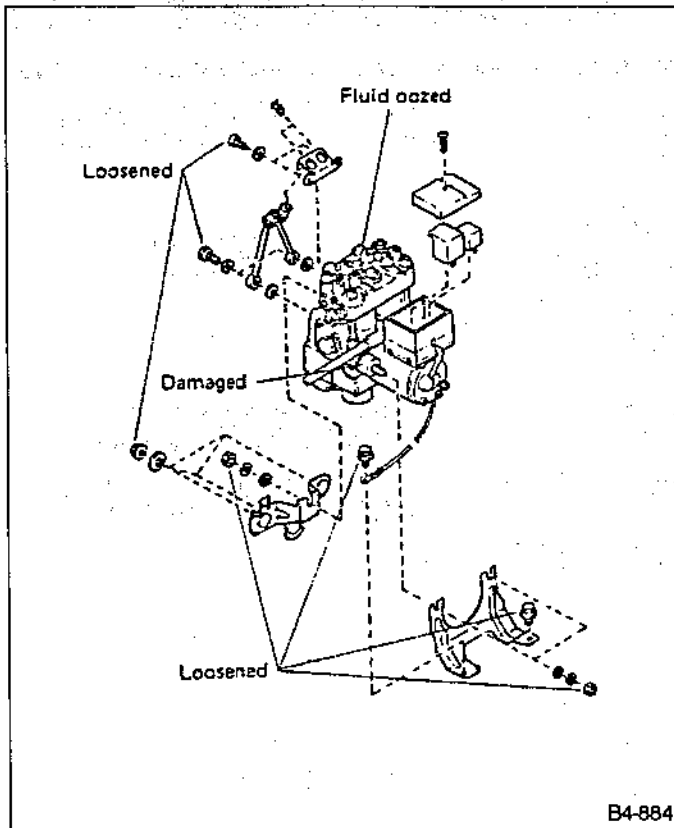


Fig. 196

1) Check parts for traces of brake fluid or dents. Clean parts and tighten pipe connections, etc. if traces of brake fluid are noted. Replace hydraulic unit if parts are excessively dented or damaged.

2) Check bracket for looseness or improper installation, damper for damage, and attaching nuts for looseness.

Specifications	Parts must be tightly in place and free from damage.
----------------	--

3) Check connectors for improper installation.

Specifications	Connectors must be tight and secure.
----------------	--------------------------------------

4) Check each relay as a single unit. Refer to "Trouble Code 9" for inspection of motor relay and "Trouble Code 10" for valve relay.

5) Valve inspection

Refer to step 1 under "Trouble Code 1 through 4" for instructions.

PEDAL SYSTEM AND CONTROL CABLES

4-5

SUBARU®

1992

SERVICE MANUAL



	Page
M MECHANISM AND FUNCTION	2
1. Pedal Effort Reducing Mechanism	2
2. Hydraulic Clutch Pedal System [TURBO]	3
S SPECIFICATIONS AND SERVICE DATA	4
C COMPONENT PARTS	5
1. Pedal (Manual Transmission)	5
2. Pedal (Automatic Transmission)	7
W SERVICE PROCEDURE	8
1. Pedal	8
2. Clutch Cable	14
3. Accelerator Cable	15
4. Speedometer Cable	16
T TROUBLESHOOTING	17

M MECHANISM AND FUNCTION

1. Pedal Effort Reducing Mechanism

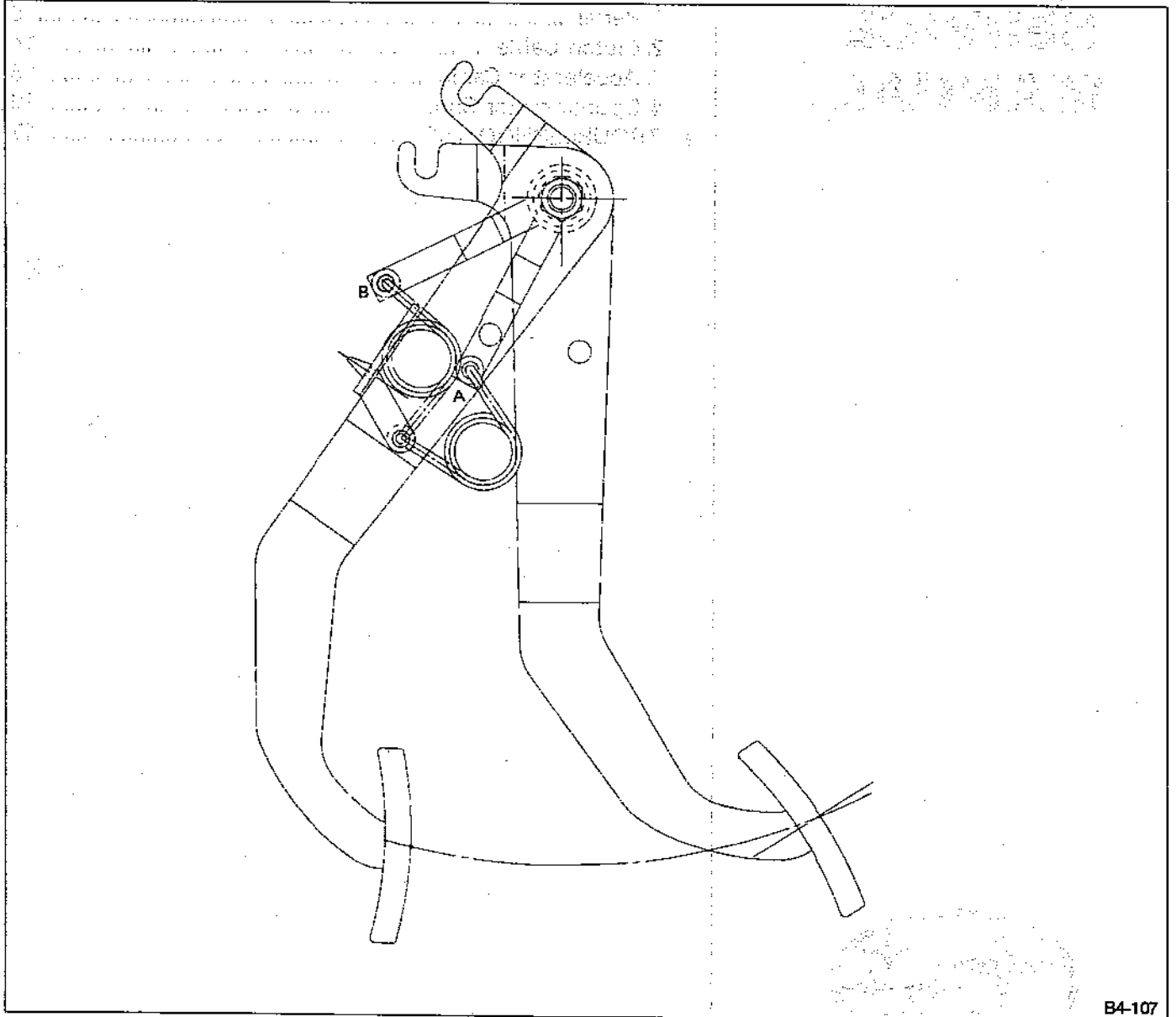
An arm is made integral with the clutch pedal, and spring-hook is connected to the arm end bushing.

The pedal effort reducing mechanism uses a mechanical turnover system as shown below. It is installed on vehicles which require a large force for the clutch pedal.

A: CONSTRUCTION

B: OPERATION

When the clutch pedal is depressed, point A moves toward point B, spring-hook makes a swing. The pedal depressing effort becomes small when the prolonged line of the spring-hook passes over the center of the pedal shaft.



B4-107

Fig. 1

2. Hydraulic Clutch Pedal System [TURBO]

A: CONSTRUCTION

The hydraulic clutch pedal is connected to the master cylinder (which produces oil pressure) via a rod.

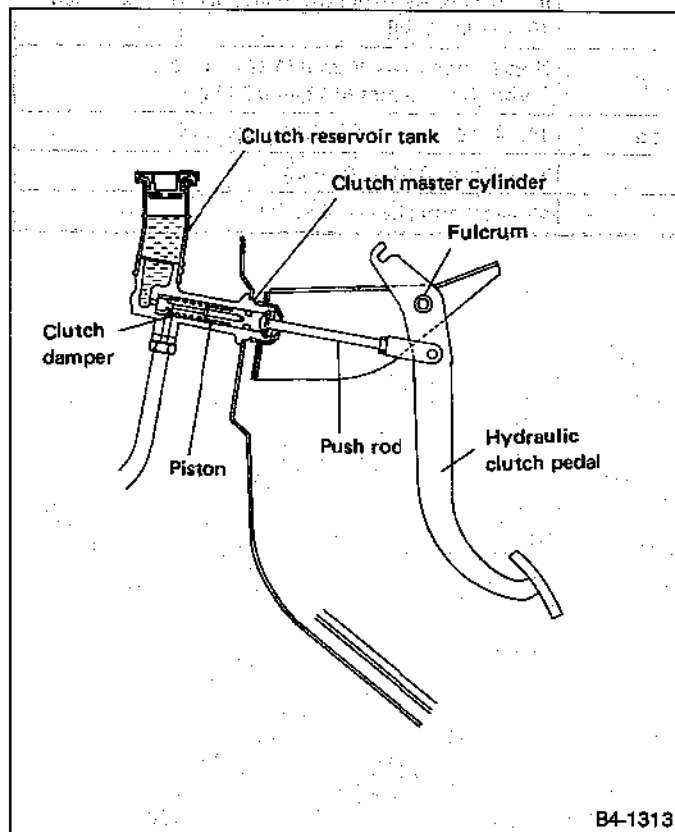


Fig. 2

B: OPERATION

The operating principle of the hydraulic clutch pedal system is similar to that of a mechanical clutch pedal system except that a return spring returns the clutch pedal to the original position.

S SPECIFICATIONS AND SERVICE DATA

A: SERVICE DATA

Brake pedal	Free play		1 — 3 mm (0.04 — 0.12 in) [Depress brake pedal pad with a force of less than 10 N (1 kg, 2 lb)]
Clutch pedal	Free play	At clutch pedal pad	Non-Turbo: 10 — 20 mm (0.39 — 0.79 in) Turbo: 3 — 15 mm (0.12 — 0.59 in)
	Full stroke	At clutch pedal pad	145 — 150 mm (5.71 — 5.91 in)
Accelerator pedal	Free play	At pedal pad	1 — 4 mm (0.04 — 0.16 in)
	Stroke	At pedal pad	46 — 50 mm (1.81 — 1.97 in)

2. TURBO

Tightening torque: N·m (kg·m, ft·lb)

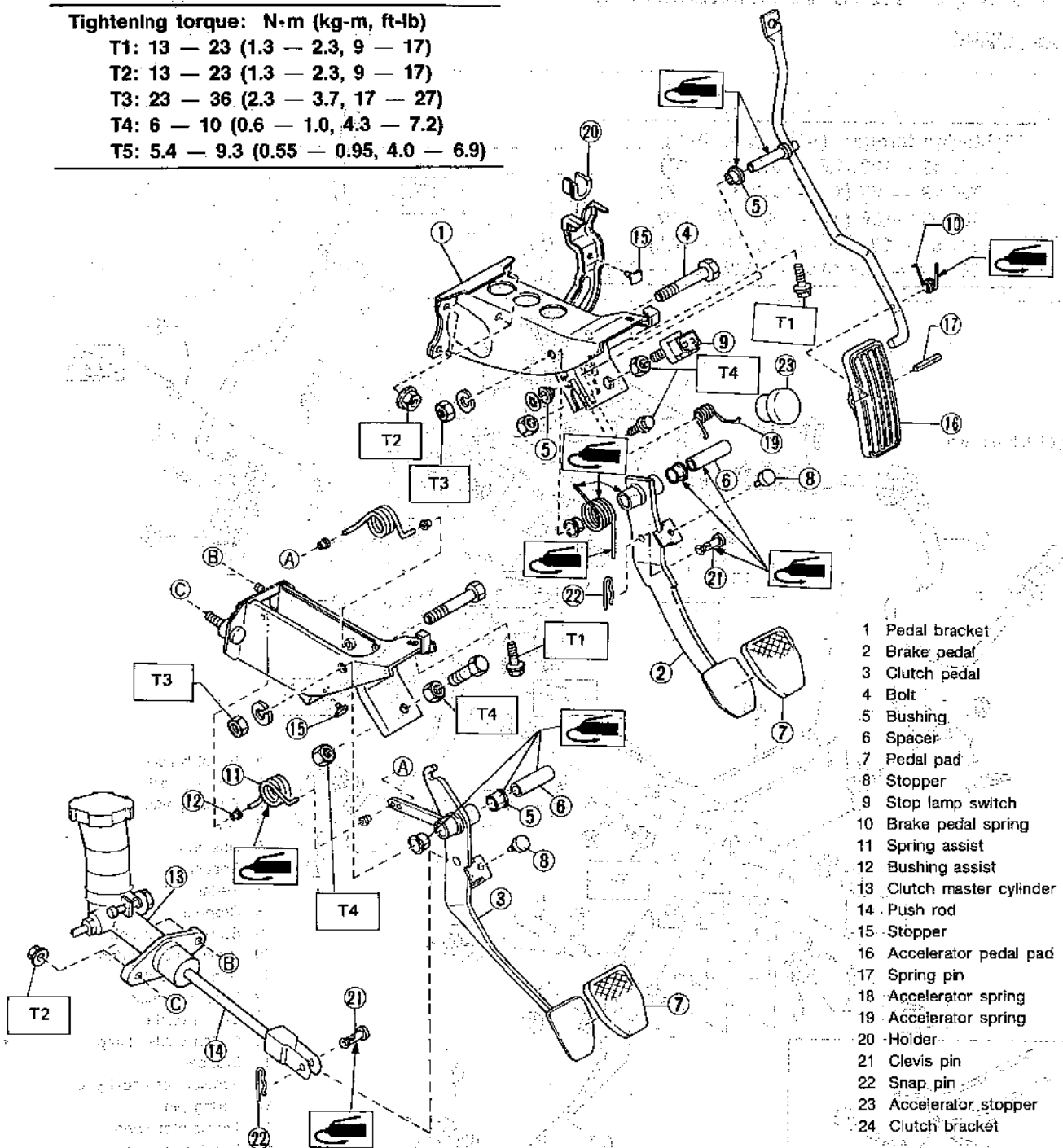
T1: 13 — 23 (1.3 — 2.3, 9 — 17)

T2: 13 — 23 (1.3 — 2.3, 9 — 17)

T3: 23 — 36 (2.3 — 3.7, 17 — 27)

T4: 6 — 10 (0.6 — 1.0, 4.3 — 7.2)

T5: 5.4 — 9.3 (0.55 — 0.95, 4.0 — 6.9)



- 1 Pedal bracket
- 2 Brake pedal
- 3 Clutch pedal
- 4 Bolt
- 5 Bushing
- 6 Spacer
- 7 Pedal pad
- 8 Stopper
- 9 Stop lamp switch
- 10 Brake pedal spring
- 11 Spring assist
- 12 Bushing assist
- 13 Clutch master cylinder
- 14 Push rod
- 15 Stopper
- 16 Accelerator pedal pad
- 17 Spring pin
- 18 Accelerator spring
- 19 Accelerator spring
- 20 Holder
- 21 Clevis pin
- 22 Snap pin
- 23 Accelerator stopper
- 24 Clutch bracket

Fig. 4

B4-1554

W SERVICE PROCEDURE

1. Pedal

A: ON-CAR SERVICE

1. BRAKE PEDAL

1) Check position of pedal pad.
If it is not in specified value, adjust it by adjusting brake booster operating rod length.

2) Check free play by operating pedal by hand.
If it is not in specified value, adjust it by adjusting position of stop lamp switch.

Be careful not to rotate stop lamp switch.

3) Apply grease to operating rod connecting pin to prevent it from wearing.

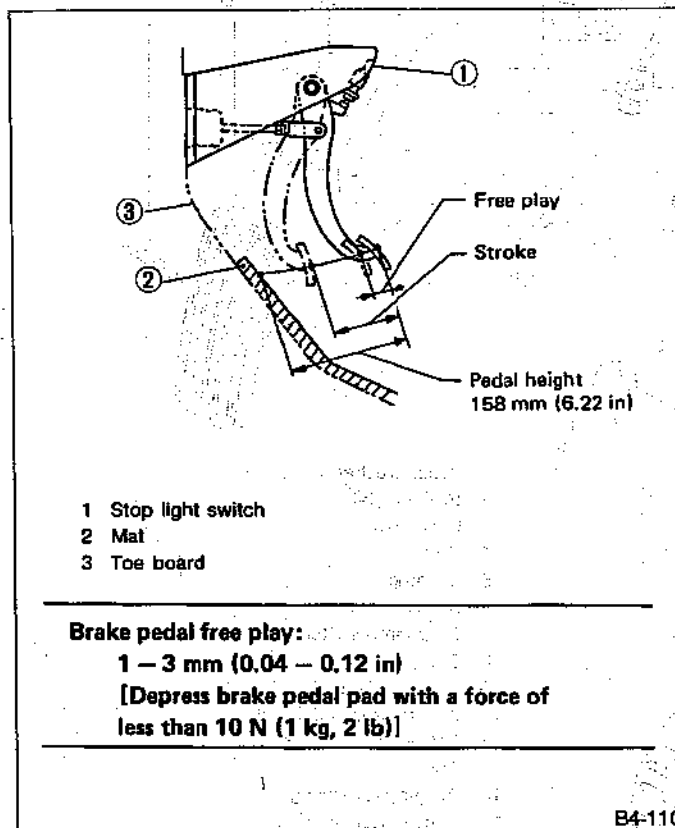


Fig. 6

2. CLUTCH PEDAL

1) Check clutch pedal free play by operating pedal by hand.

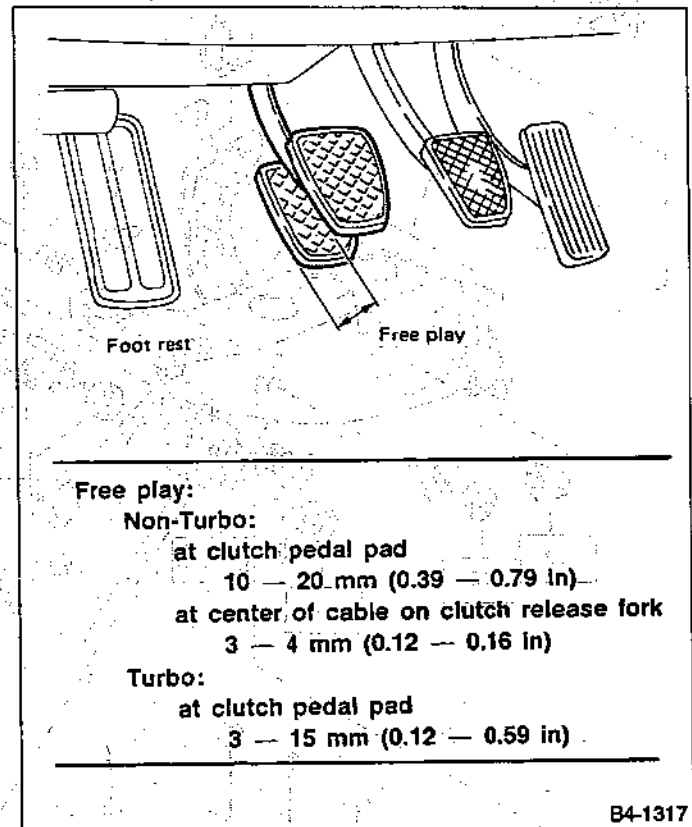


Fig. 7

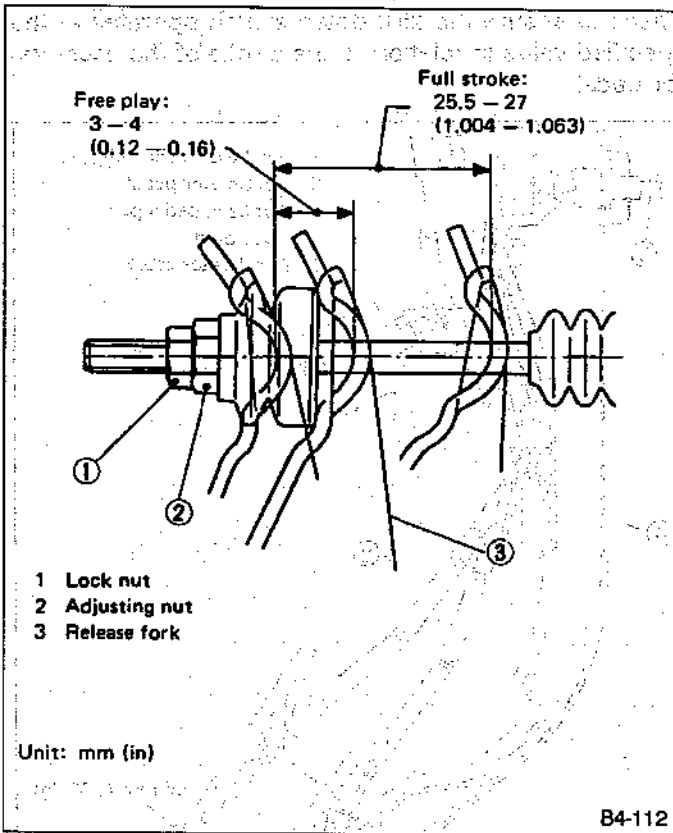


Fig. 8

2) Mechanical application type [Non-TURBO]

- (1) If it is not in specified value, adjust it by turning adjusting nut on engine side end of clutch cable.
- (2) Apply grease to connecting portion of clutch pedal and clutch cable.

3) Hydraulic application type [TURBO]

- (1) If it is out of specification, loosen lock nut for push rod and adjust push rod by turning in the direction that shortens or lengthens it.

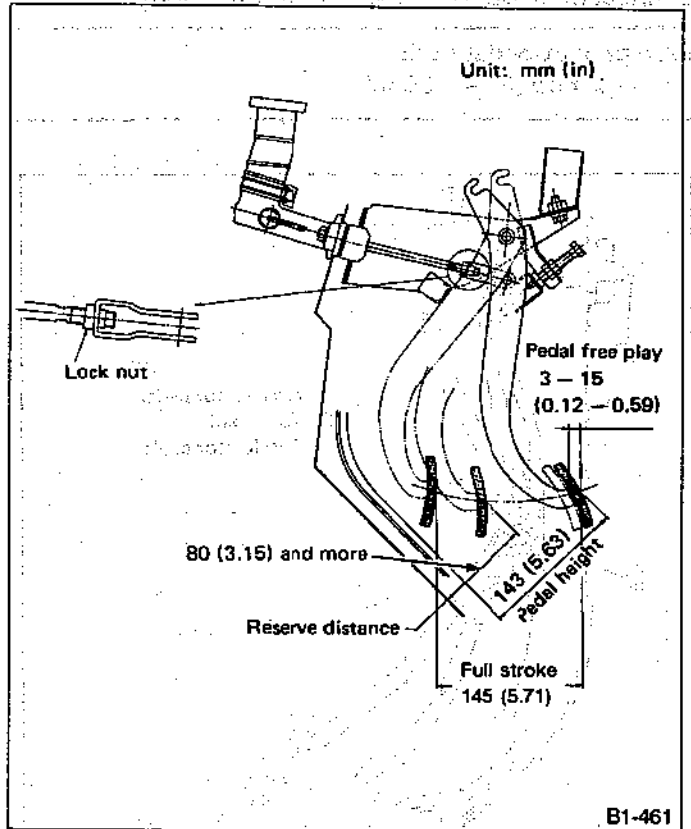


Fig. 9

Tightening torque (Adjusting nut):

9 — 11 N·m (0.9 — 1.1 kg-m, 6.5 — 8.0 ft-lb)

- (2) Check the fluid level on the outside of the clutch master cylinder tank. If the level is below "MIN", add clutch fluid to bring it up to "MAX".

Recommended clutch fluid:

FMVSS No. 116, fresh DOT 3 or DOT 4 brake fluid

3. ACCELERATOR PEDAL

Check pedal stroke and free play by operating accelerator pedal by hand. If it is not within specified value, adjust it by turning nut connecting accelerator cable to throttle body.

Free play at pedal pad:

0 — 2 mm (0 — 0.08 in)

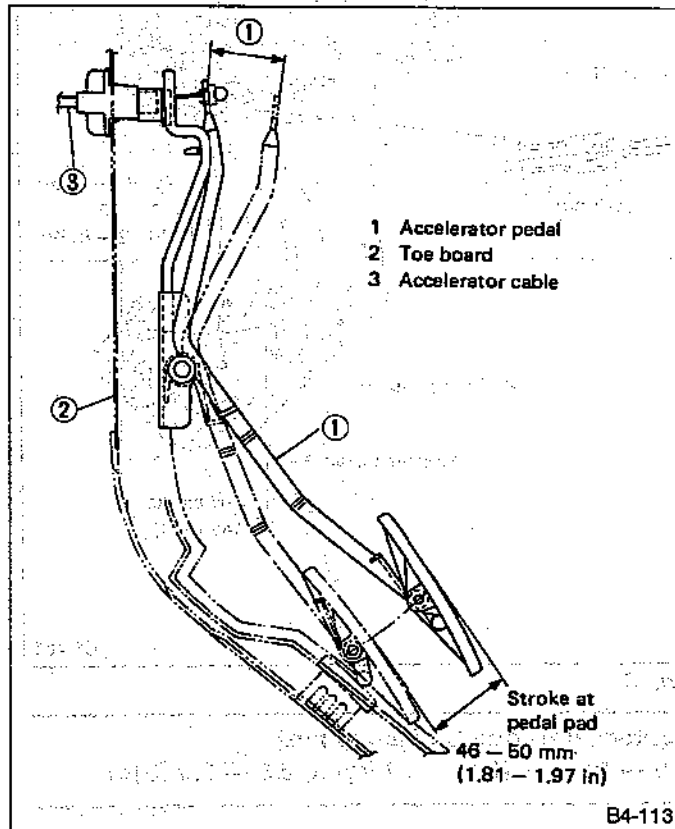


Fig. 10

Check to ensure the kick down switch operates at the specified value in relation to the stroke of the accelerator pedal.

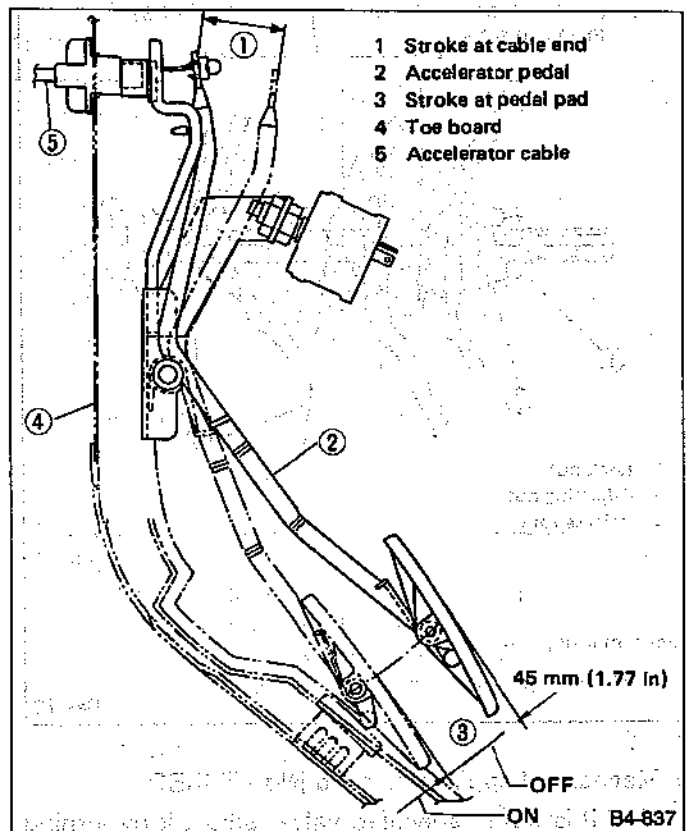


Fig. 11

B: REMOVAL

1. ACCELERATOR AND BRAKE PEDAL ASSY

- 1) Disconnect ground cable from battery.
- 2) Disconnect accelerator cable from throttle body.

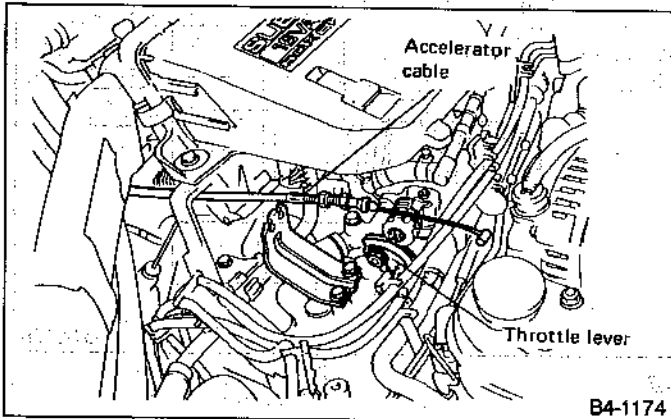


Fig. 12

- 3) Attach a wrench to the casing cap above toeboard, and turn the casing cap clockwise to remove it.

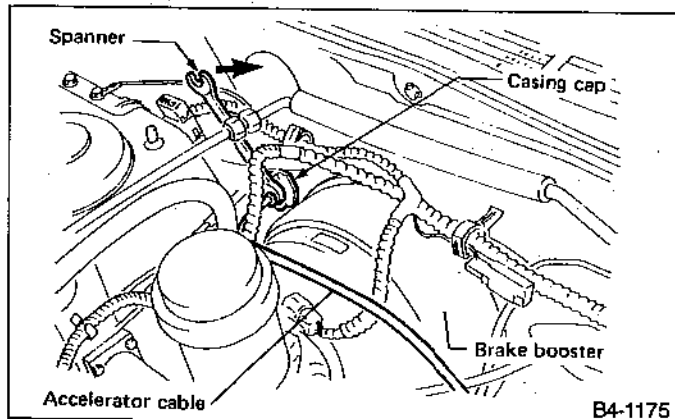


Fig. 13

- 4) Remove lower instrument cover located above accelerator and brake pedals.
 - 5) Remove bushing from front end of accelerator pedal.
- While using a standard screwdriver or a suitable tool to rear of bushing, lever off bushing.

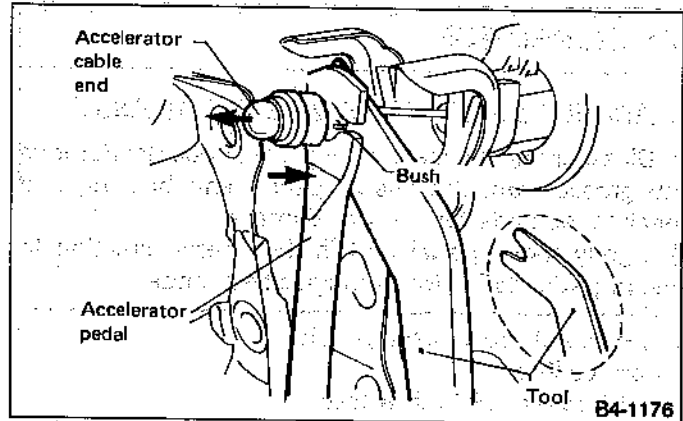


Fig. 14

- 6) Disconnect accelerator and stop lamp switch harness connectors.
- 7) Remove the pin which connects brake pedal and operating rod.

Operating rod length is preset at the factory. Do not attempt to loosen the lock nut.

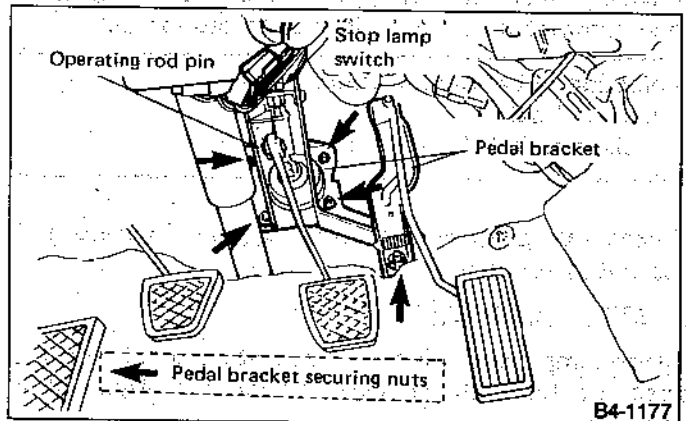


Fig. 15

- 8) Remove nuts which secure pedal bracket.

2. CLUTCH PEDAL ASSY

1) Mechanical application type [Non-TURBO]

- (1) Disconnect end of clutch cable on the engine side.
- (2) Remove two flange nuts at bracket location.
- (3) Remove lower instrument cover.
- (4) Remove the bolt which secures bracket.
- (5) Remove clutch pedal ASSY together with clutch cable.

2) Hydraulic application type [TURBO]

- (1) Remove master cylinder cover.
- (2) Remove master cylinder mounting nuts.
- (3) Remove snap pin and clevis pin that join pushrod and clutch pedal.
- (4) Remove clutch pedal and bracket as a unit.

C: INSPECTION**1. ACCELERATOR AND BRAKE PEDAL ASSY**

- 1) Disassemble accelerator and brake pedals. Remove any grease from the shaft, spacer, and bushing and check these parts for wear or damage.
- 2) Lightly move pedal pad in the lateral direction to ensure pedal deflection is in specified range.

Deflection of accelerator pedal:

Service limit

5.0 mm (0.197 in) or less

If excessive deflection is noted, replace bushing and clip with new ones.

2. CLUTCH PEDAL

- 1) Check pedal shaft and bushing for wear or damage.
- 2) Move brake and clutch pedal pads in the lateral direction with a force of approximately 10 N (1 kg, 2 lb) to ensure pedal deflection is in specified range.

Deflection of brake and clutch pedal:

Service limit

5.0 mm (0.197 in) or less

If excessive deflection is noted, replace bushing and clip with new ones.

3. STOP LAMP SWITCH

If stop lamp switch does not operate properly (or if it does not stop at the specified position), replace with a new one.

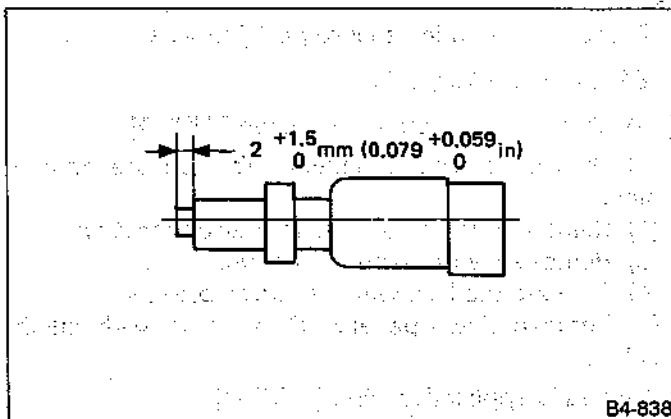


Fig. 16

4. KICK DOWN SWITCH

If kick down switch does not operate properly (or if it does not stop at the specified position), replace with a new one.

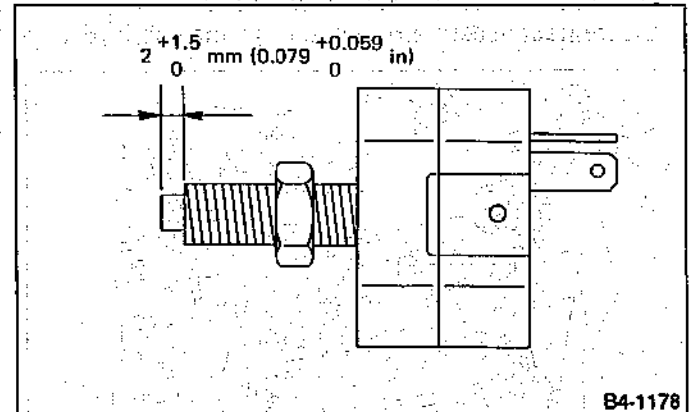


Fig. 17

D: INSTALLATION

1. ACCELERATOR AND BRAKE PEDAL ASSY

To install, reverse removal procedures. Observe the following:

- 1) After installing accelerator cable casing cap on toeboard, check that casing cap and holder are properly connected at position "A" while holding a mirror on the compartment side.

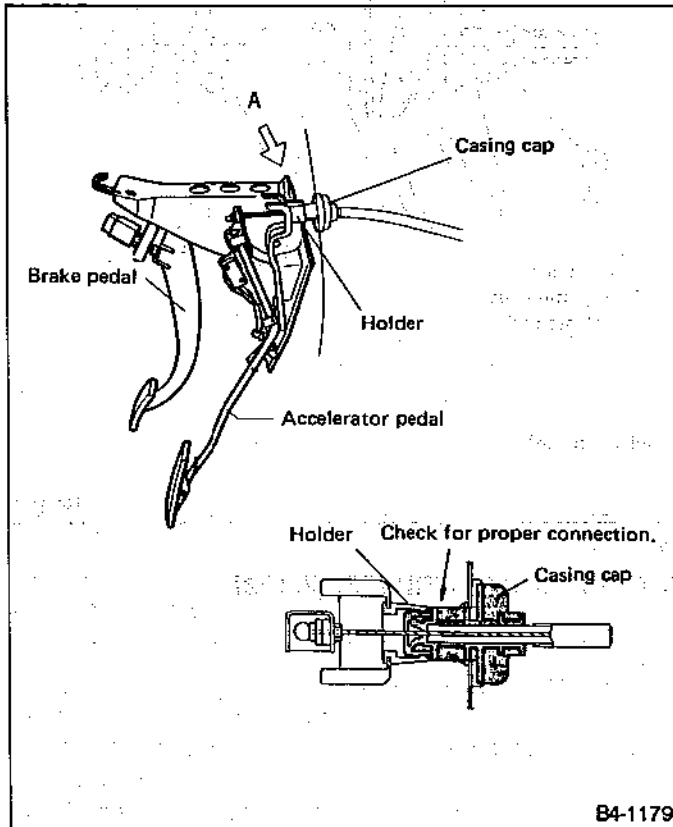


Fig. 18

- 2) Check brake pedal free play and clearance (pedal height above the floor).

Free play:

1 — 3 mm (0.04 — 0.12 in)

Clearance:

ℓ1: 150 — 160 mm (5.91 — 6.30 in)

ℓ2: 179 — 185 mm (7.05 — 7.28 in)

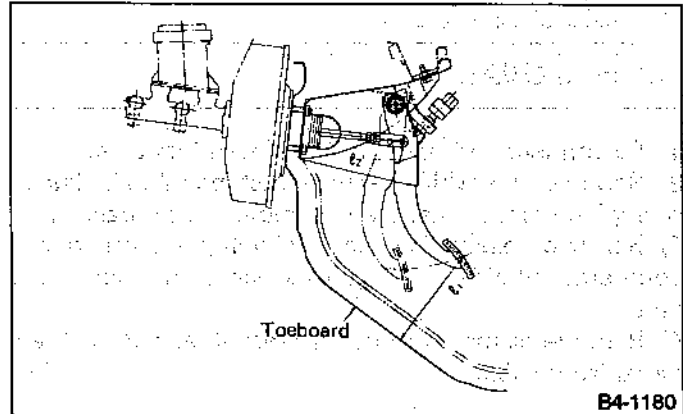


Fig. 19

- 3) After installing accelerator cable, check the clearance between throttle lever and outer end cable.

Clearance: 1 — 8 mm (0.04 — 0.31 in)

- 4) Check that kick down switch turns ON when pedal is depressed 45 mm (1.77 in), which is measured at pedal pad.

2. CLUTCH PEDAL

1) Mechanical application type [Non-TURBO]

- (1) Clean clutch cable, pedal shaft and bushing, and apply grease.
- (2) Connect clutch pedal and clutch cable as follows:
- (3) Attach clutch cable to pedal hook.
- (4) Insert end of clutch cable into bracket, and secure it with a clamp.
- (5) Check clutch pedal free play. If it is less than the specified value, adjust it on transmission side.

2) Hydraulic application type [TURBO]

- (1) Clean clutch pedal shaft and bushing, and apply grease.
- (2) Install pushrod and clutch pedal with clevis pin and snap pin.
- (3) Install master cylinder.
- (4) Install master cylinder cover.
- (5) Check clutch pedal free play.

Refer to ON-CAR SERVICE 4-5. [W1A2]

2. Clutch Cable

A: REMOVAL

- 1) Disconnect end of cable on release fork side.
- 2) Remove nuts which secure clutch pedal to bulkhead of engine compartment, and remove cable bracket.
- 3) Remove bolts which secure clutch pedal on driver's compartment side, and remove pedal and cable as a unit.
- 4) Remove clamp from pedal bracket, and disconnect pedal from cable.

B: INSTALLATION

- 1) Attach end of cable to pedal hook.
- 2) Insert end of outer cable into bracket, and secure it with a clamp.
- 3) To assure proper cable and pedal operation, adjust as follows:
After attaching end of cable to pedal hook, adjust stopper until it lightly contacts lower end of auto adjuster.
- 4) Check that pedal returns to its original position. Disconnect boot at end of outer cable, and insert inner cable into bracket.
- 5) Position bushing located at end of outer cable in bracket.
- 6) Install boot onto bushing at end of outer cable.
- 7) Insert cable into place through groove in release lever.

8) Adjustment after cable installation

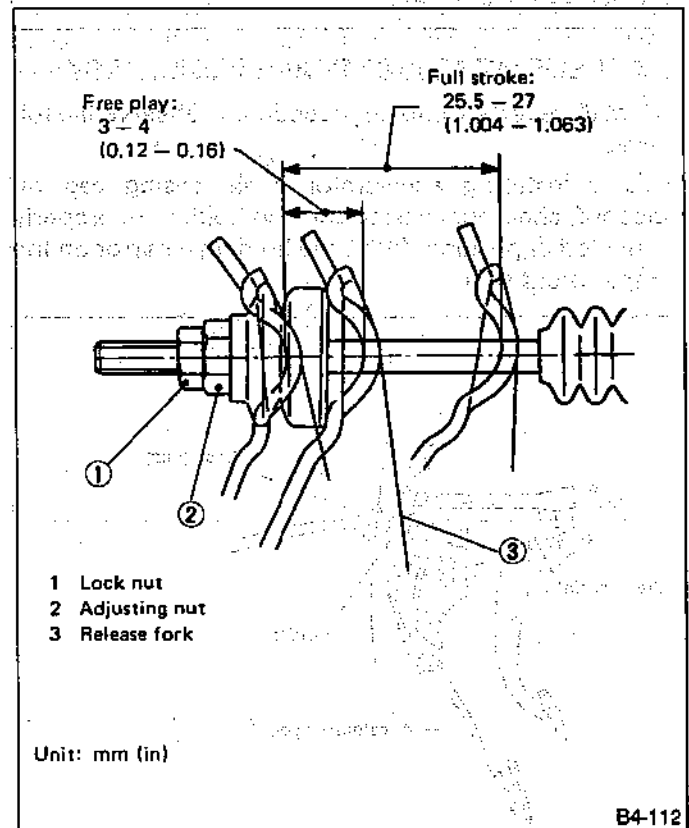
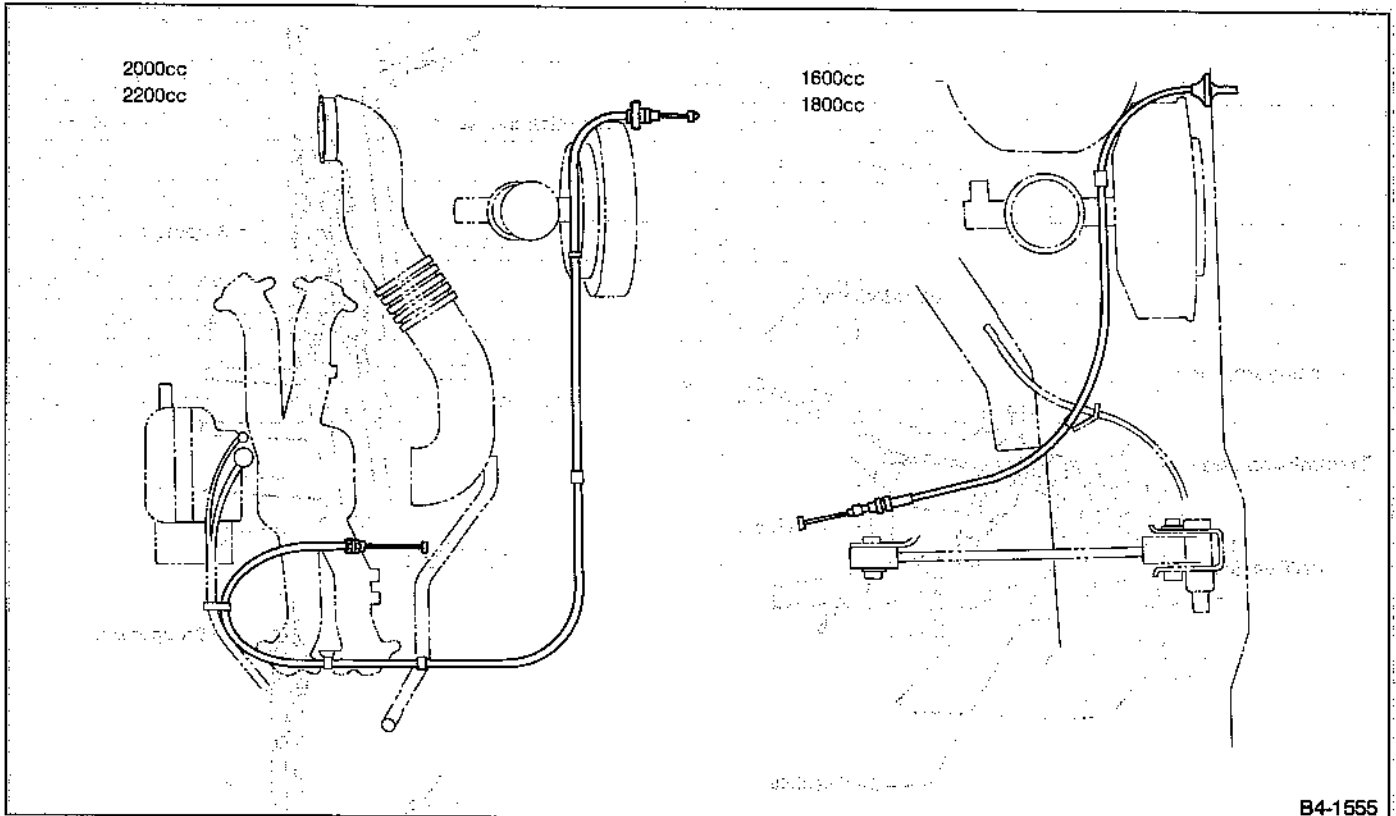


Fig. 20

Refer to ON-CAR SERVICE [W1A2]

3. Accelerator Cable



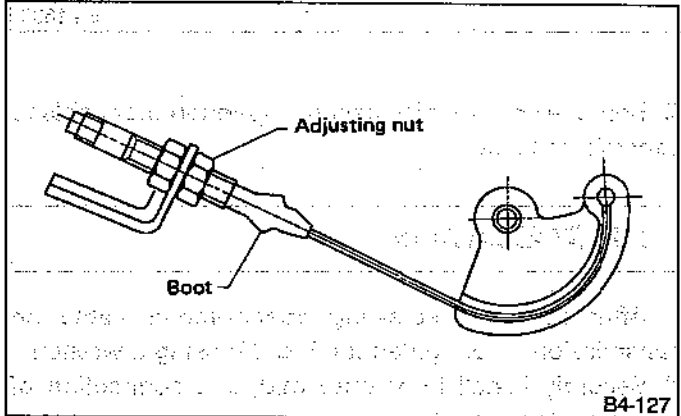
B4-1555

Fig. 21

A: REMOVAL

- 1) Disconnect accelerator cable from connector inside engine compartment first.
- 2) Remove adjusting nut and boot from accelerator cable bracket.
- 3) Separate accelerator cable from bracket, then unlock inner cable.

- Be careful not to bend inner cable.
- 5) Disconnect cable end from accelerator cable bracket inside driver compartment.
 - 6) Remove clip inside engine compartment.
 - 7) Working inside engine compartment, remove cable connection by turning toe board clockwise.



B4-127

Fig. 22

- 4) Remove cable end from throttle cam using your fingertips.

B: INSTALLATION

- 1) Pass inner cable through toe board hole and route inside driver compartment. Install cable bushing on accelerator pedal end.
- 2) While turning accelerator cable counterclockwise, transfer it to driver compartment through toe board hole.
- 3) Connect accelerator cable to upper holder of accelerator pedal.
- 4) Install clip inside engine compartment.
- 5) To install cable to throttle cam, reverse the order of the removal procedures.

Tightening torque:
 10 — 18 N·m (1.0 — 1.8 kg-m, 7 — 13 ft-lb)

4. Speedometer Cable

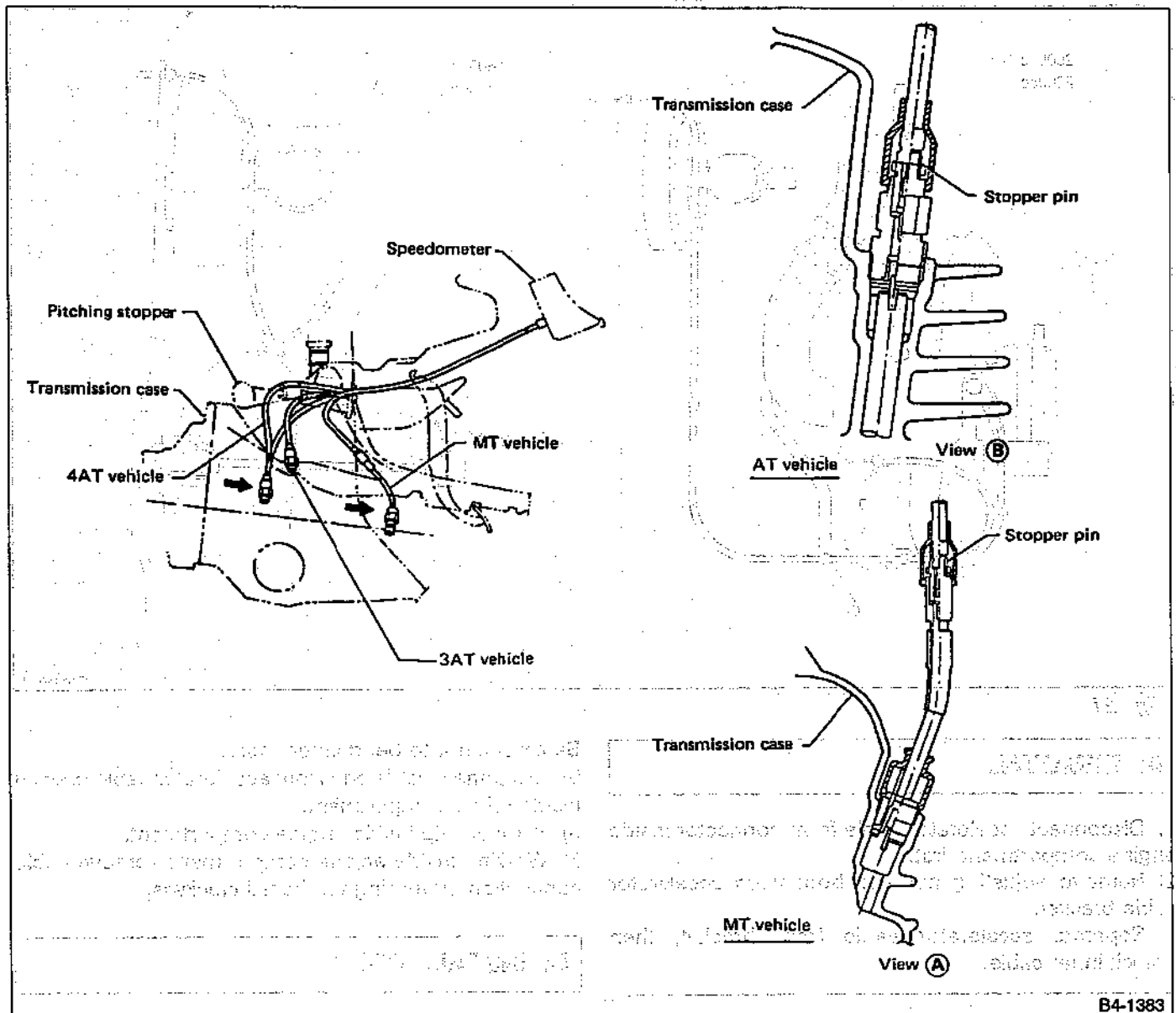


Fig. 23

A: REMOVAL

- 1) Remove speedometer cable, starting with its midpoint connection inside engine compartment.
- 2) While holding up boot located at speedometer cable connection, slightly expand clip. Extract speedometer cable by pulling it upward 2 to 3 mm (0.08 to 0.12 in) on speedometer side. Then, release clip and remove speedometer cable.
- 3) After disconnecting cable from speedometer, pull it out of toe board.

- 4) Remove screw which secures speedometer cable to transmission side.

B: INSTALLATION

- 1) After manually screwing speedometer cable on transmission side, tighten it 45 to 90° using a wrench.
- 2) Securely install boot onto midpoint connection of speedometer cable to prevent entry of water.

B4-1383

T TROUBLESHOOTING

Trouble	Corrective action
Excessively worn brake pedal pad	Replace.
Failure of clutch and/or accelerator pedals to operate	Connect cables correctly.
Speedometer does not work.	Connect speedometer cable correctly.
Stop lamp switch does not light up.	Adjust position of stop lamp switch.
Stop lamp switch is not smooth and/or stroke is not correct.	Replace.
Insufficient pedal play	Adjust pedal play.
Brake pedal freeplay insufficient	Adjust pedal freeplay.
Maladjustment of brake pedal or booster push rod	Inspect and adjust.
Excessively worn and damaged pedal shaft and/or bushing	Replace bushing and/or shaft with new one.

HEATER AND VENTILATOR

4-6

SUBARU

1992

SERVICE MANUAL

July 1991
Printed in Japan
Subaru Corp.
Tokyo, Japan



	Page
M MECHANISM AND FUNCTION	2
1. Outline	2
2. Control Unit	6
3. Mode Door Control	9
4. Intake Door Control	11
5. Blower System	12
S SPECIFICATIONS AND SERVICE DATA	13
C COMPONENT PARTS	14
1. Heater System	14
2. Heater Unit	15
3. Intake Unit	16
4. Control Unit	17
W SERVICE PROCEDURE	19
1. Heater Unit	19
2. Blower Motor Assembly	19
3. Control Unit	20
4. Mode Door Motor	22
5. Intake Door Motor	23
6. Temperature Control Cable	23

M MECHANISM AND FUNCTION

1. Outline

The heater control unit is located in the middle portion of the instrument panel.

The heater unit is provided with mode doors and an air mix door. The intake unit is provided with an intake door and blower motor. The heater unit and the intake unit are regulated by their control units.

Fresh outside air is introduced into the compartment through the center and side ventilator grilles when the ventilator fan is operated.

Fresh outside air can also be introduced through the side vents on the driver's and passenger's sides by the ram pressure produced while the vehicle is running.

A high performance heater system is adopted. All models are equipped with the front side window defroster and some models are further equipped with the rear heater duct.

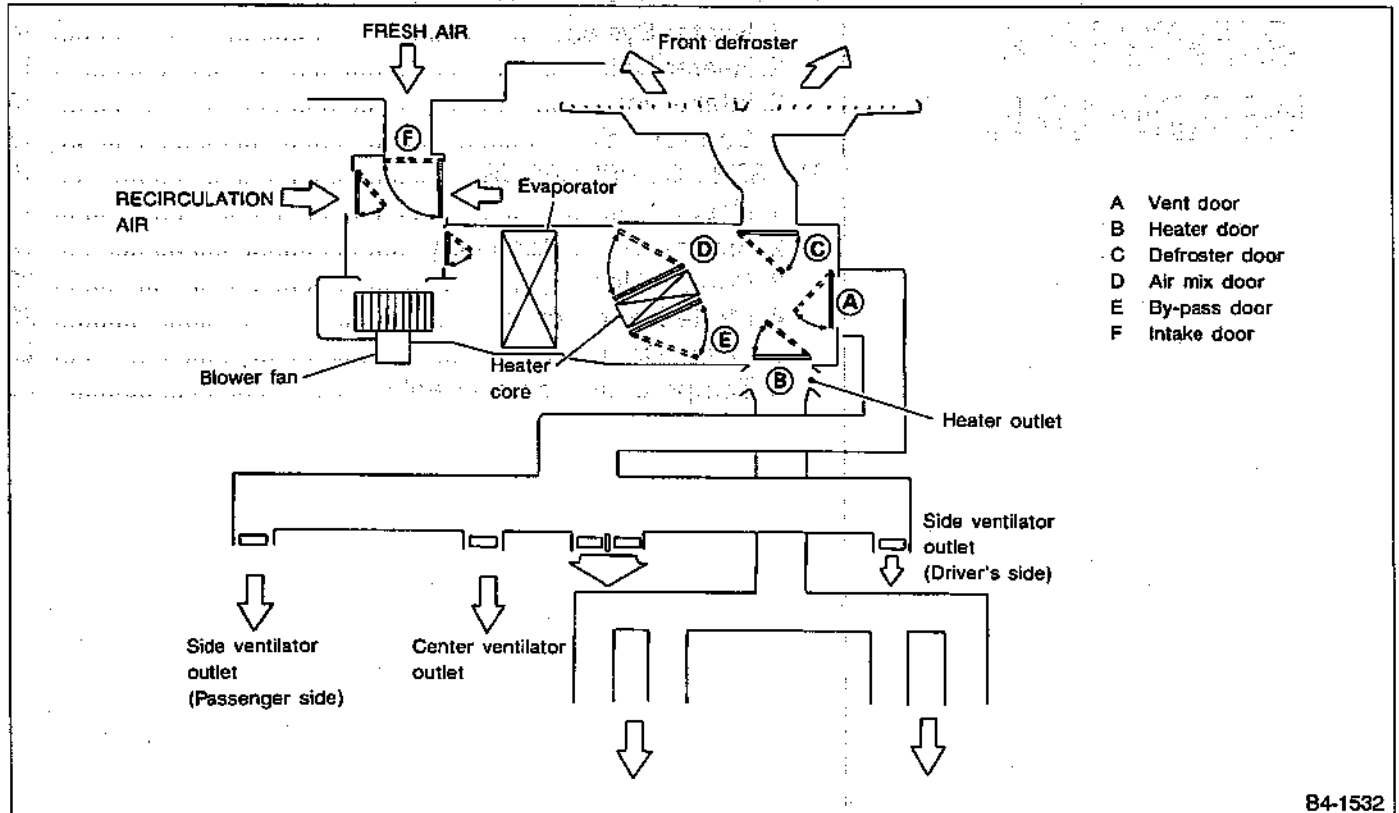


Fig. 1

B4-1532

1. SYSTEM FLOW

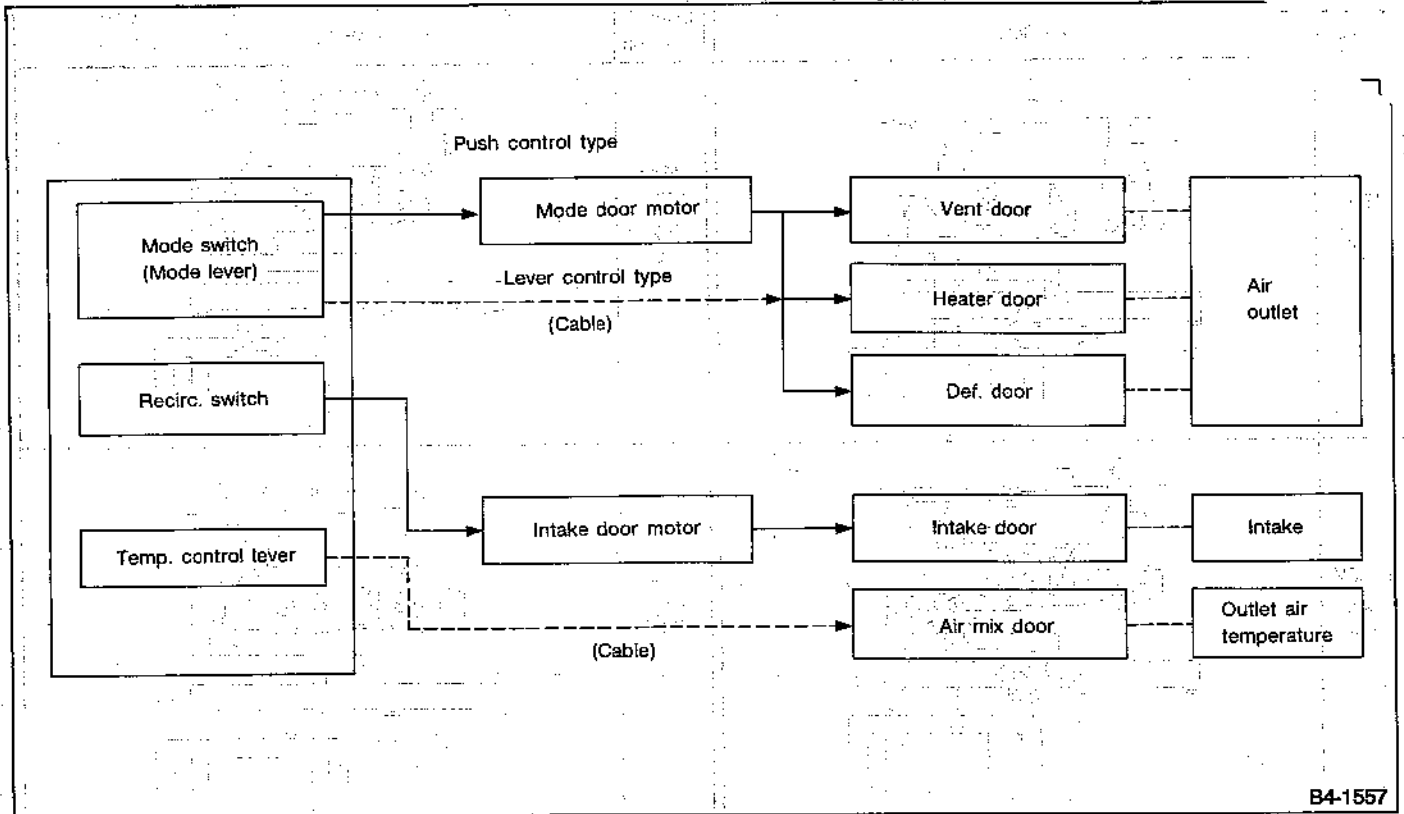


Fig. 2

2. AIR FLOW

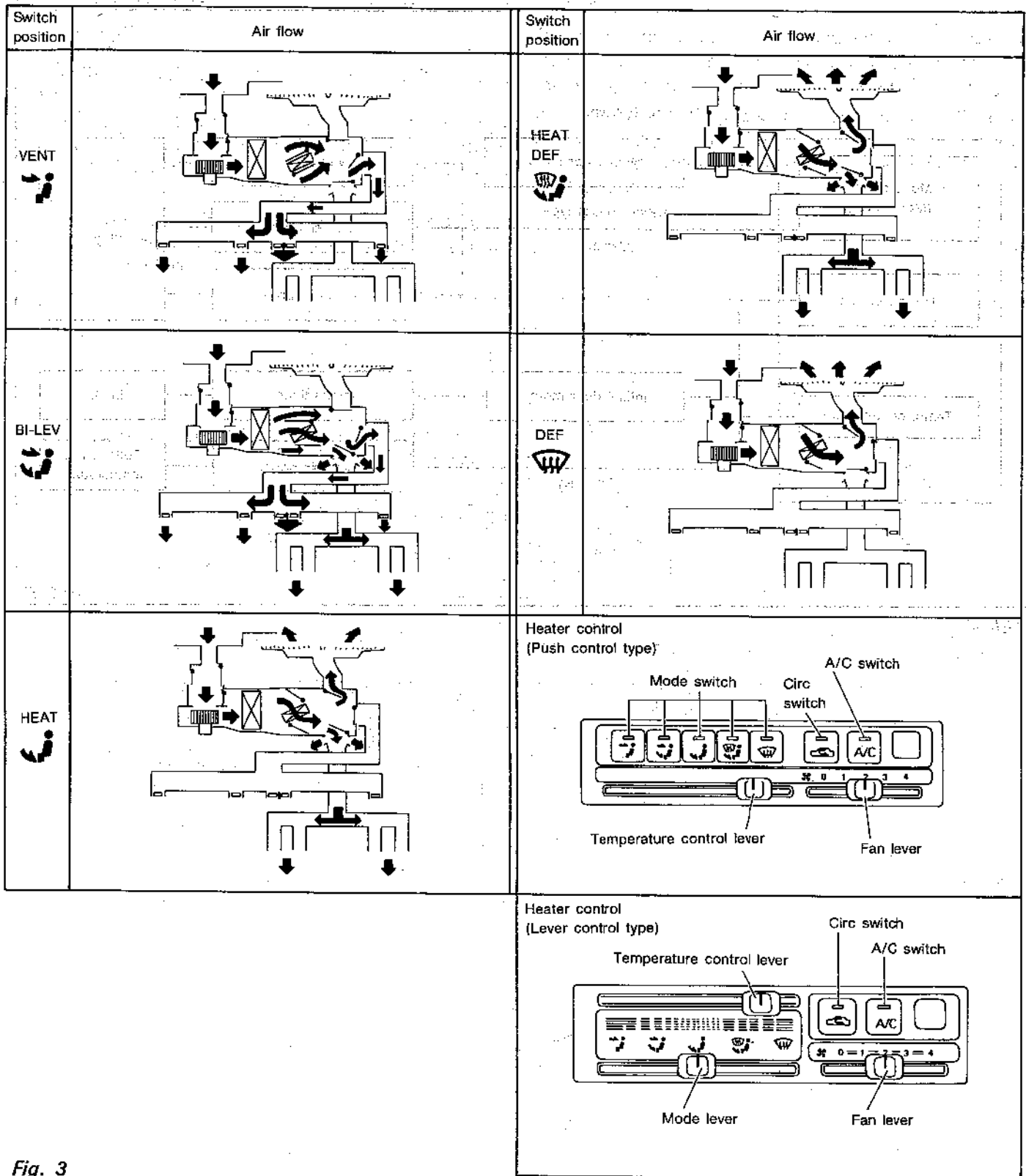


Fig. 3

B4-1558

3. AIR DISTRIBUTION RATIO

Figure shows air distribution ratios corresponding to mode selector switch or lever positions.

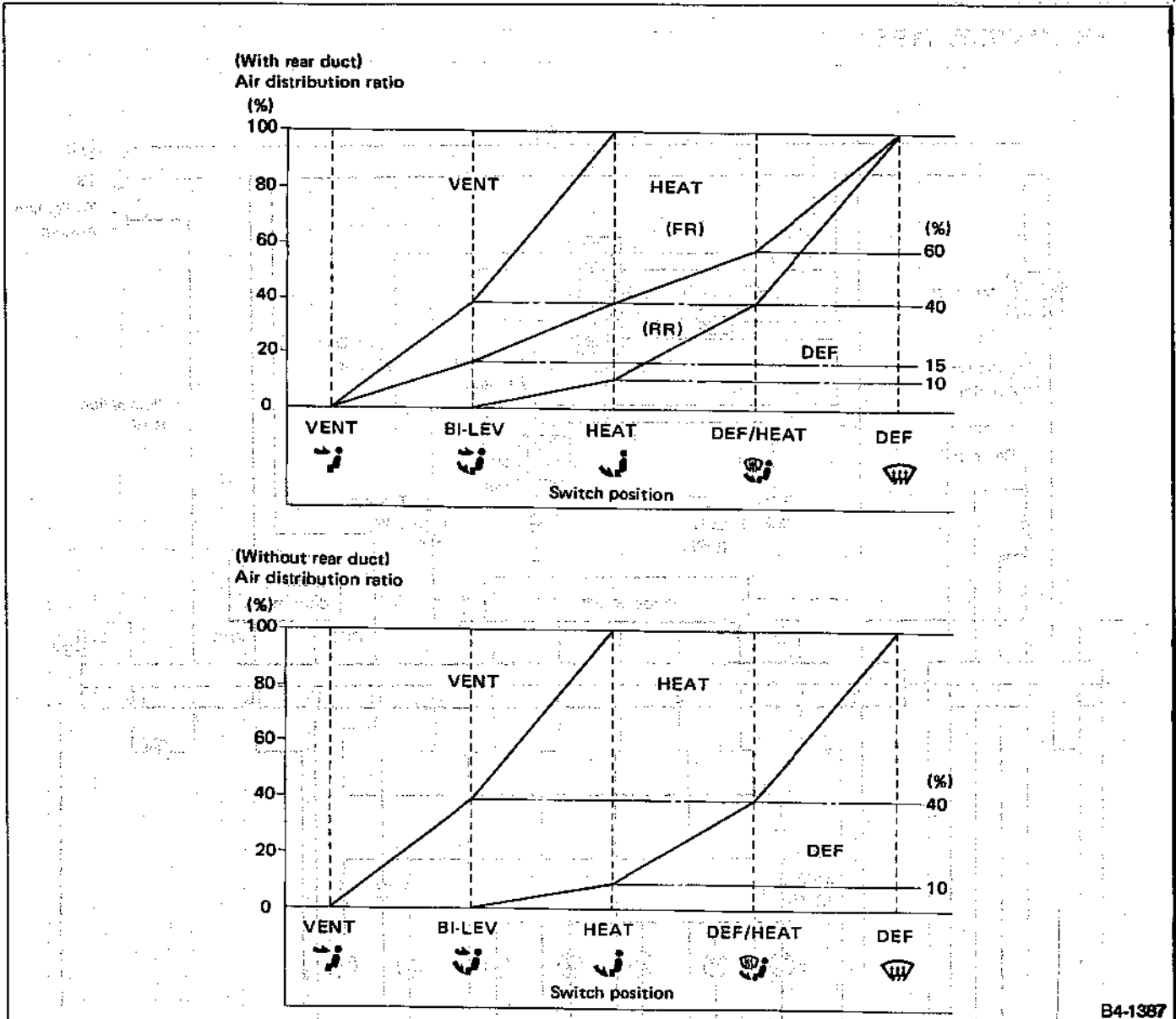


Fig. 4

B4-1387

2. Control Unit

OPTIONAL EQUIPMENT FOR A

of optional equipment with production of such equipment
available only as factory order

A: SCHEMATIC

1. PUSH CONTROL TYPE

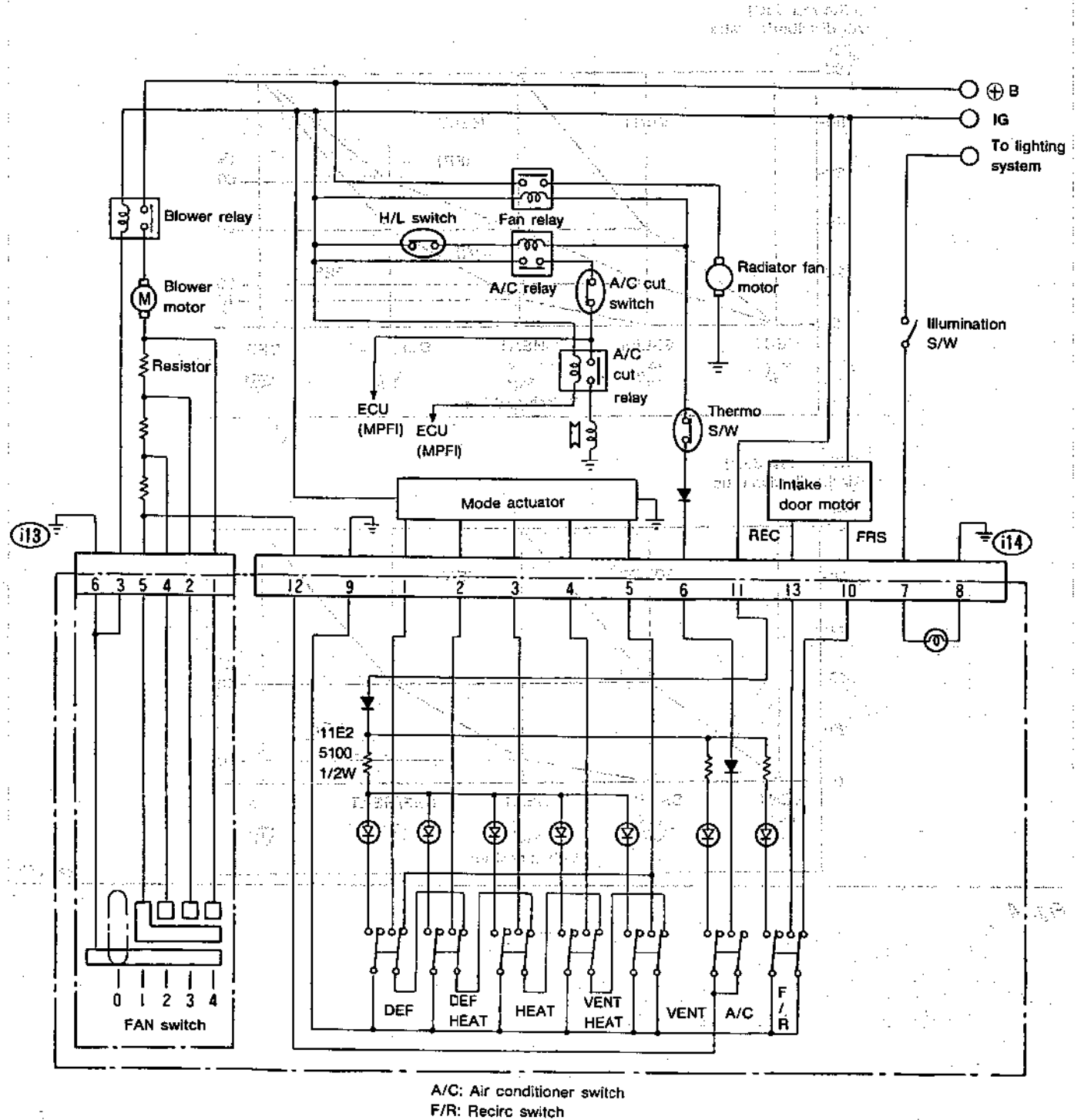
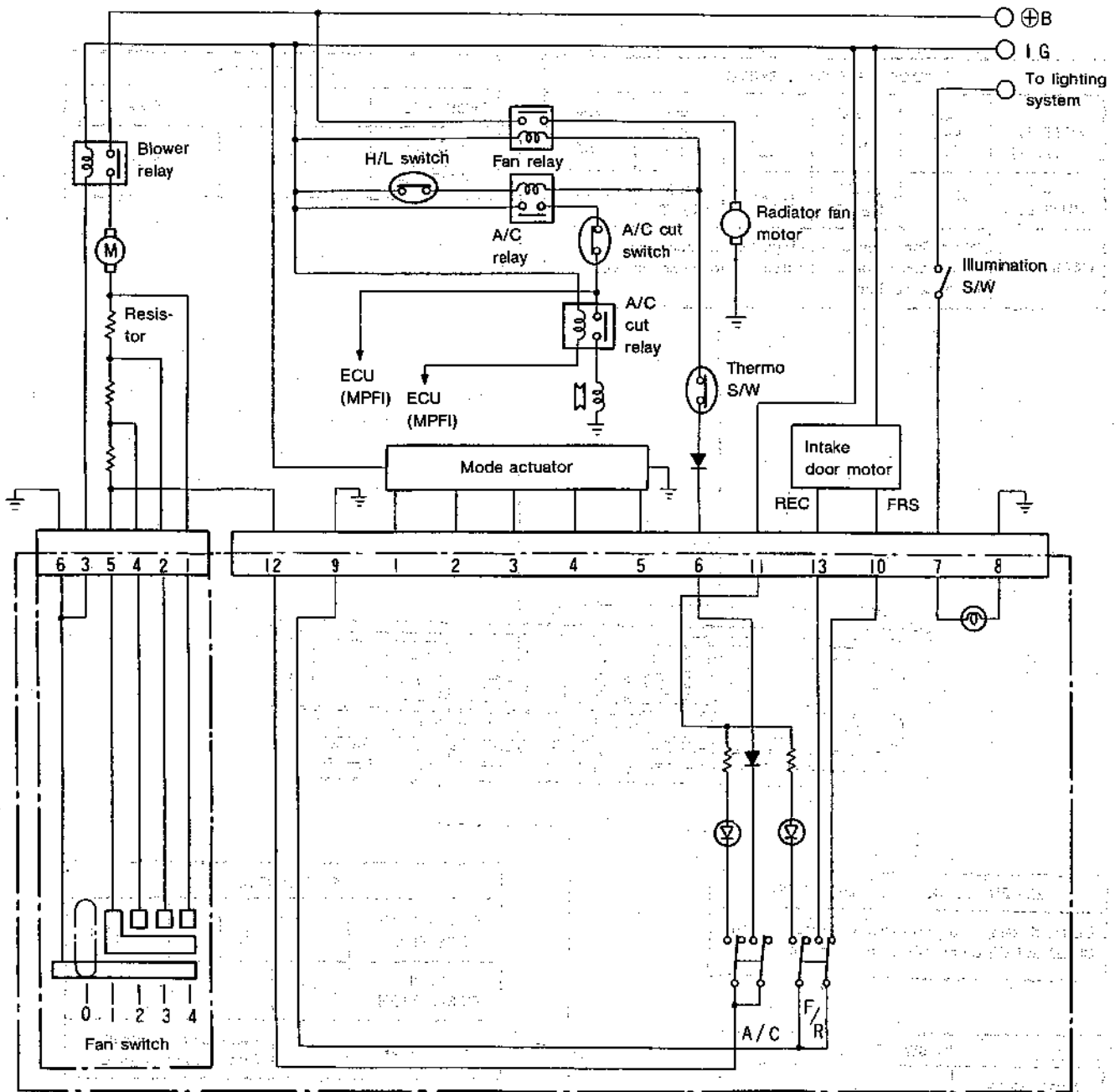


Fig. 5

B4-1535

2. LEVER CONTROL TYPE



A/C: Air conditioner switch
F/R: Recirc switch

B4-1560

Fig. 6

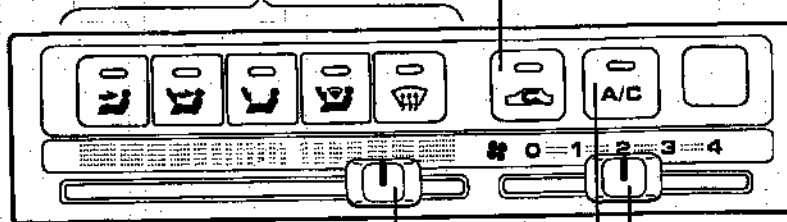
B: FUNCTION

*: Lever control type differs from push control type in that it is provided with a MODE lever. Functional features for the two types are the same.

PUSH CONTROL TYPE

* MODE SELECTOR SWITCH					
SWITCH POSITION					
AIR OUTLET	VENT	VENT HEAT	HEAT	DEF HEAT	DEF
REMARKS	When Cool Vent Switch is pushed, air comes out of VENT and air outlet selected by mode selector switch at the same time.				

RECIRC SWITCH		
INDICATOR	ON	OFF
INTAKE DOOR POSITION	RECIRC	FRESH



TEMPERATURE CONTROL LEVER
Outlet air temperature is variably controlled from COLD to HOT by air mix door and cable.

FAN SWITCH					
FAN SWITCH POSITION	0	1	2	3	4
FAN OPERATION	OFF	ON			
REMARKS	Fan speed is controlled from 1st to 4th speed.				

A/C SWITCH		
INDICATOR	* ON	OFF
COMPRESSOR	ON	OFF
REMARKS	*: When fan switch is pushed, indicator lights and compressor turns on.	

Compressor may be turned off by thermo control even though A/C switch indicator is lighted.

Fig. 7

3. Mode Door Control

A: GENERAL

The mode door motor is located on the right side of the heater unit.

It opens and closes the vent, heater and defroster doors through side links.

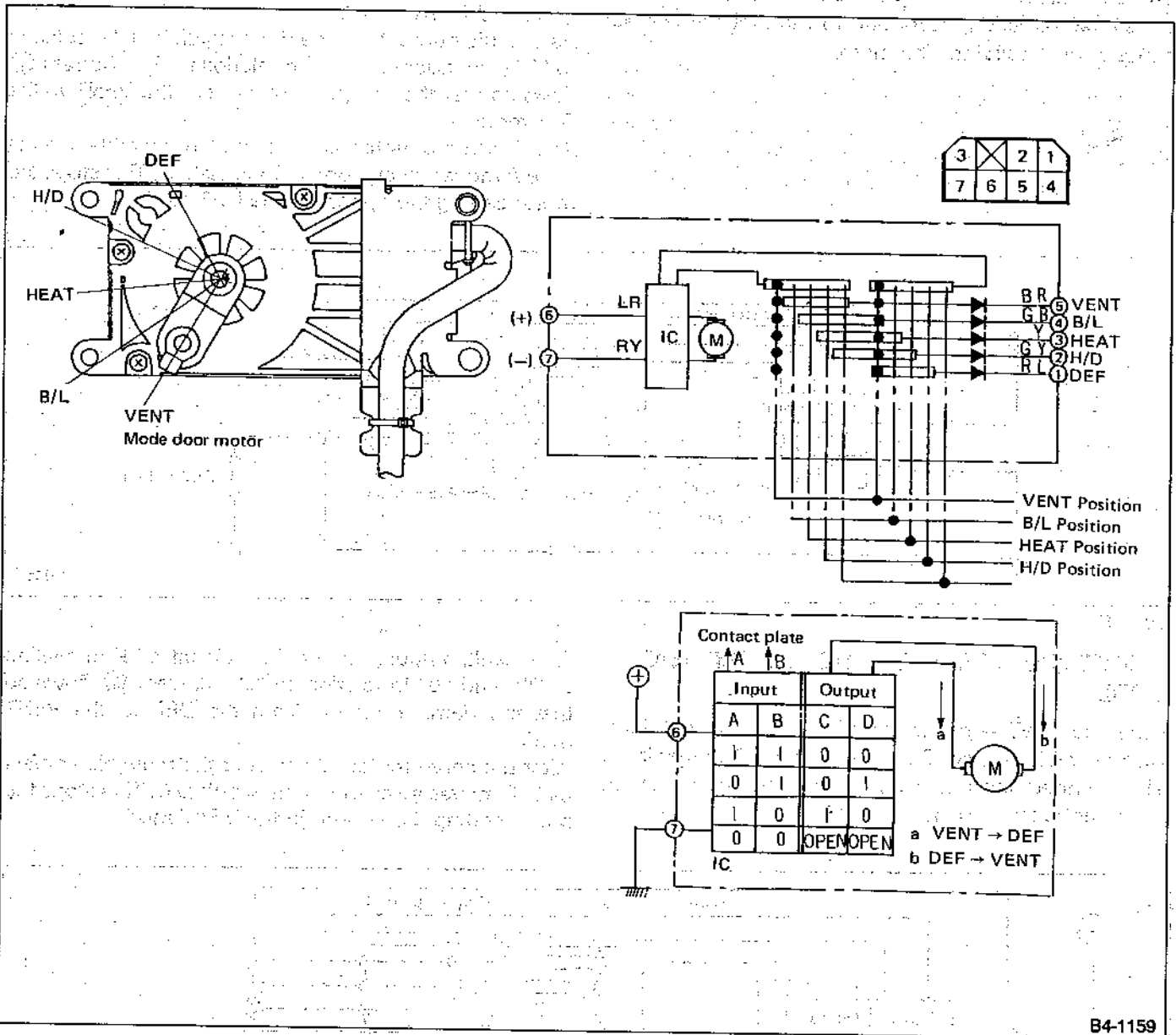


Fig. 8

B4-1159

B: OPERATION**1. DRIVE CIRCUIT**

The drive circuit rotates the servo motor in the standard or reverse direction, according to the input of contact plates A or B built into the motor.

2. SWITCHING FROM THE VENT TO THE DEF MODE

When the DEF switch is turned to "ON", current flows from movable contact A to contact plate A so that input A is grounded (current = 0). At this point, input B is not grounded (current = 1).

As a result, output from the drive circuit is "0" in relation to "C" (grounded) and "1" in relation to "D". Current ① flows so that the damper moves from the VENT to the DEF mode.

After the servo motor has rotated, the movable contact plate A moves away from contact plate C. This stops the motor setting the system in the DEF mode.

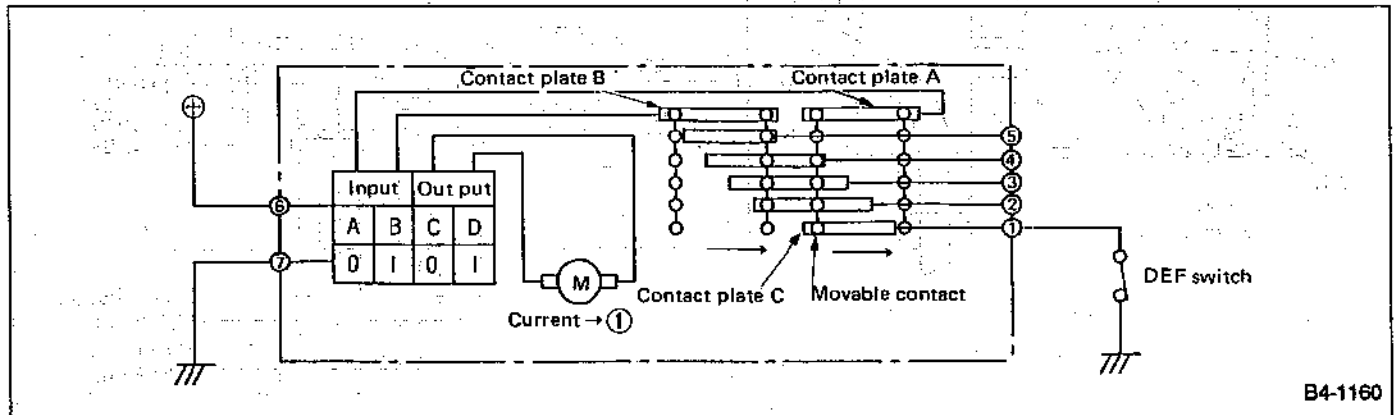


Fig. 9

3. SWITCHING FROM THE DEF TO THE VENT MODE

When the VENT switch is turned to "ON", current flows from movable contact B to contact plate B so that input B is grounded (current = 0). At this point, input A is not grounded (current = 1).

As a result, output from the drive circuit is "1" in relation to "C" and "0" in relation to "D". Current ② flows so that the damper moves from the DEF to the VENT mode.

After the servo motor has rotated the movable contact plate B moves away from contact plate C. This stops the motor setting the system in the VENT mode.

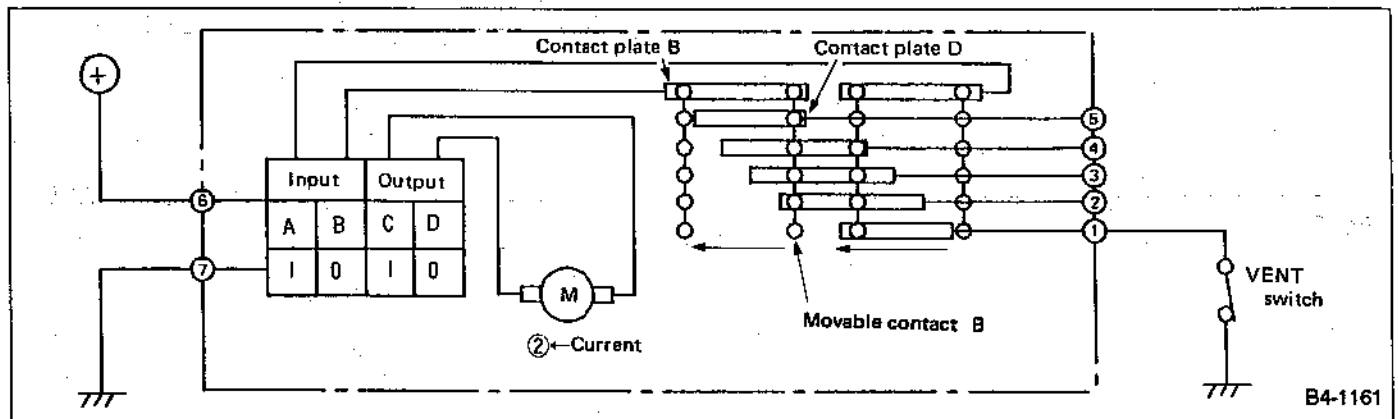


Fig. 10

4. Intake Door Control

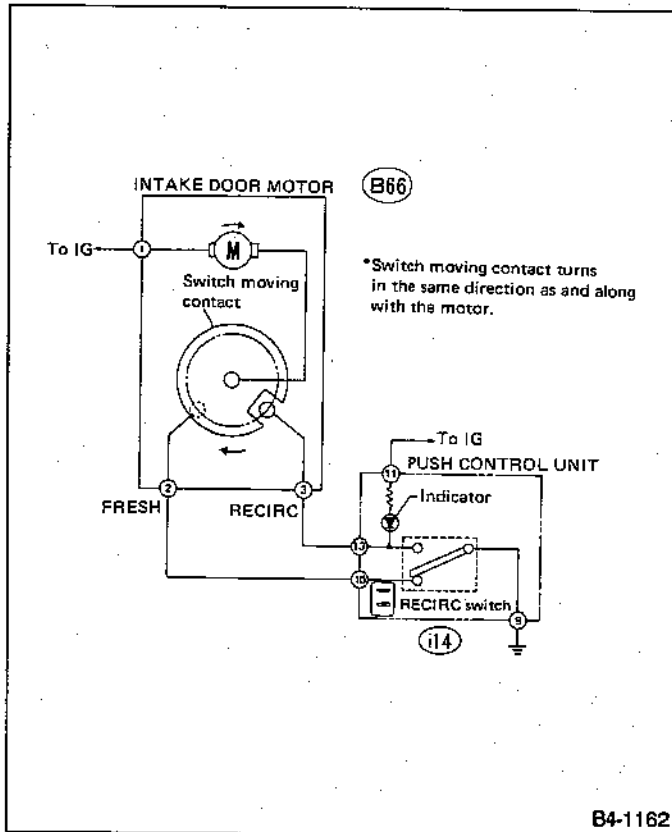


Fig. 11

Intake door motor is located on the upper part of the intake unit. It opens and closes the intake door with a rod and a link. When the RECIRC switch is set to ON (the RECIRC indicator lights), the ground line of the intake door motor is switched to terminal 2 from terminal 1. And the motor starts to rotate because the position switch contacts built into it are set to the current flow position. The contacts turn along with the motor. When they reach the non-contacts flow position, the motor will stop. The motor always turns in the same direction. When the RECIRC switch is set to OFF (the RECIRC indicator does not light), follow the same operation.

5. Blower System

Operation of the blower relay is controlled by turning ON and OFF the ignition switch. When the ignition switch is ON and the fan switch is operated from 1st to 4th speed, electric current from the battery goes through the blower motor, the resistor, the fan switch and ground. The resistor is switched by the position of the fan switch, and controls the blower motor speed from 1st to 4th.

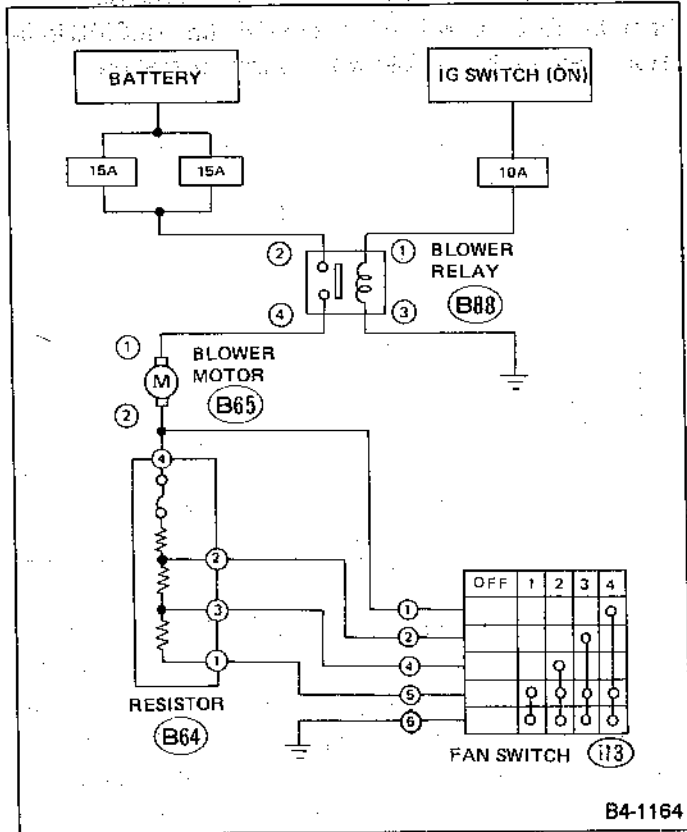


Fig. 12

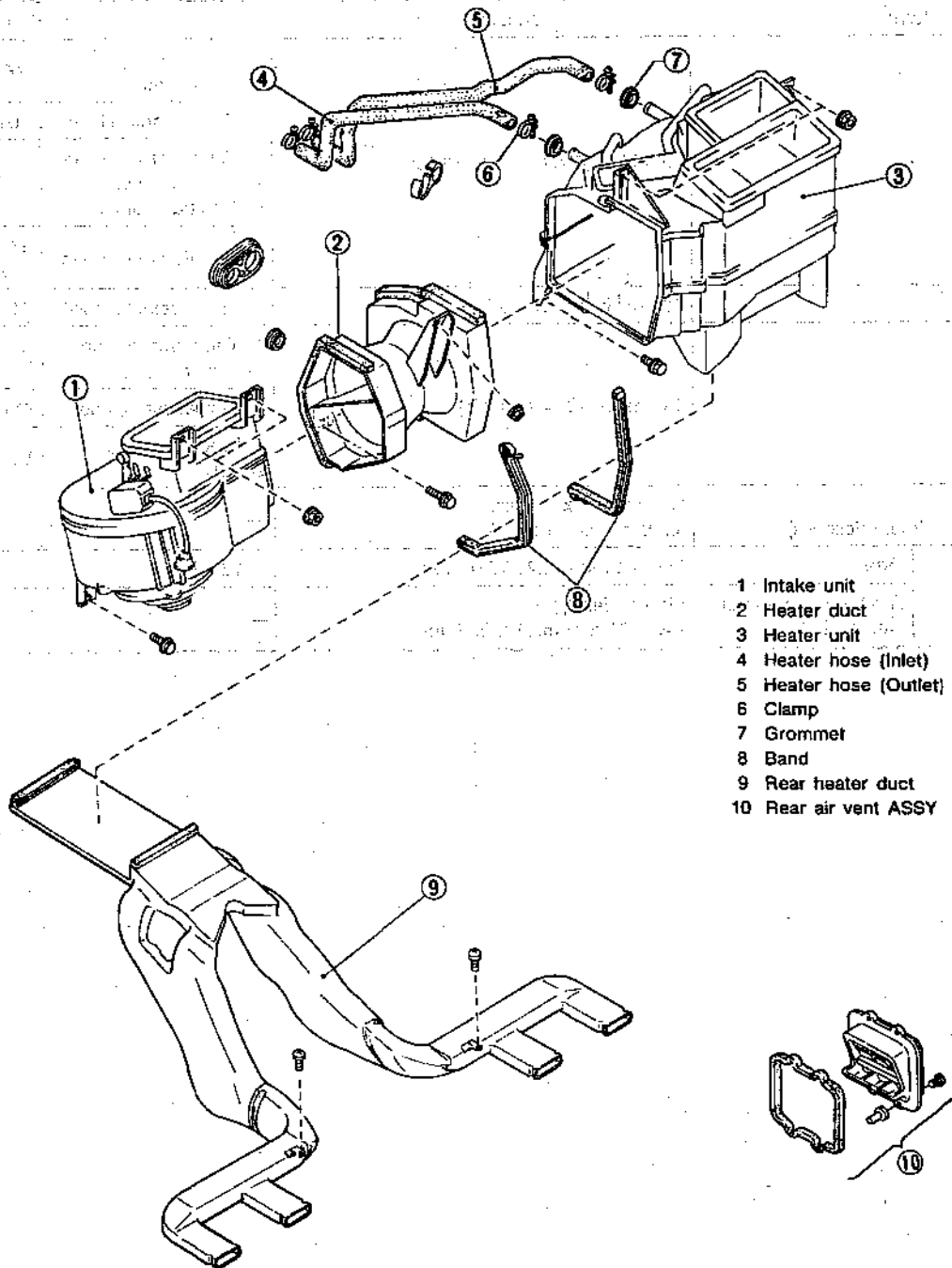
S SPECIFICATIONS AND SERVICE DATA

A: SPECIFICATIONS

Item	Specifications	Condition
Heating capacity	4.885 kW (4,200 kcal/h, 16,666 BTU/h)	• Mode selector switch : HEAT
		• Temp. control lever : Full hot
		• Temperature difference between hot water and inlet air : 65°C (149°F)
		• Hot water flow rate : 360 ℓ/h (95.1 US gal/h, 79.2 imp gal/h)
Air flow rate	300 m ³ /h (10,593 cu ft/h)	• Mode selector switch: HEAT
Max air flow rate	480 m ³ /h (16,949 cu ft/h)	• Temperature control lever : Full cold
		• Blower fan speed : 4th position
		• Mode selector switch : VENT
Heater core size (height x length x width x thickness)	159.5 x 180 x 32 mm (6.28 x 7.09 x 1.26 in)	—
Blower motor	Type	Magnet motor 220 W or less at 12.5 V
	Fan type & Size (diameter x width)	Sirocco fan type 140 x 65 mm (5.51 x 2.56 in)

C COMPONENT PARTS

1. Heater System



- 1 Intake unit
- 2 Heater duct
- 3 Heater unit
- 4 Heater hose (Inlet)
- 5 Heater hose (Outlet)
- 6 Clamp
- 7 Grommet
- 8 Band
- 9 Rear heater duct
- 10 Rear air vent ASSY

Fig. 13

B4-1537

2. Heater Unit

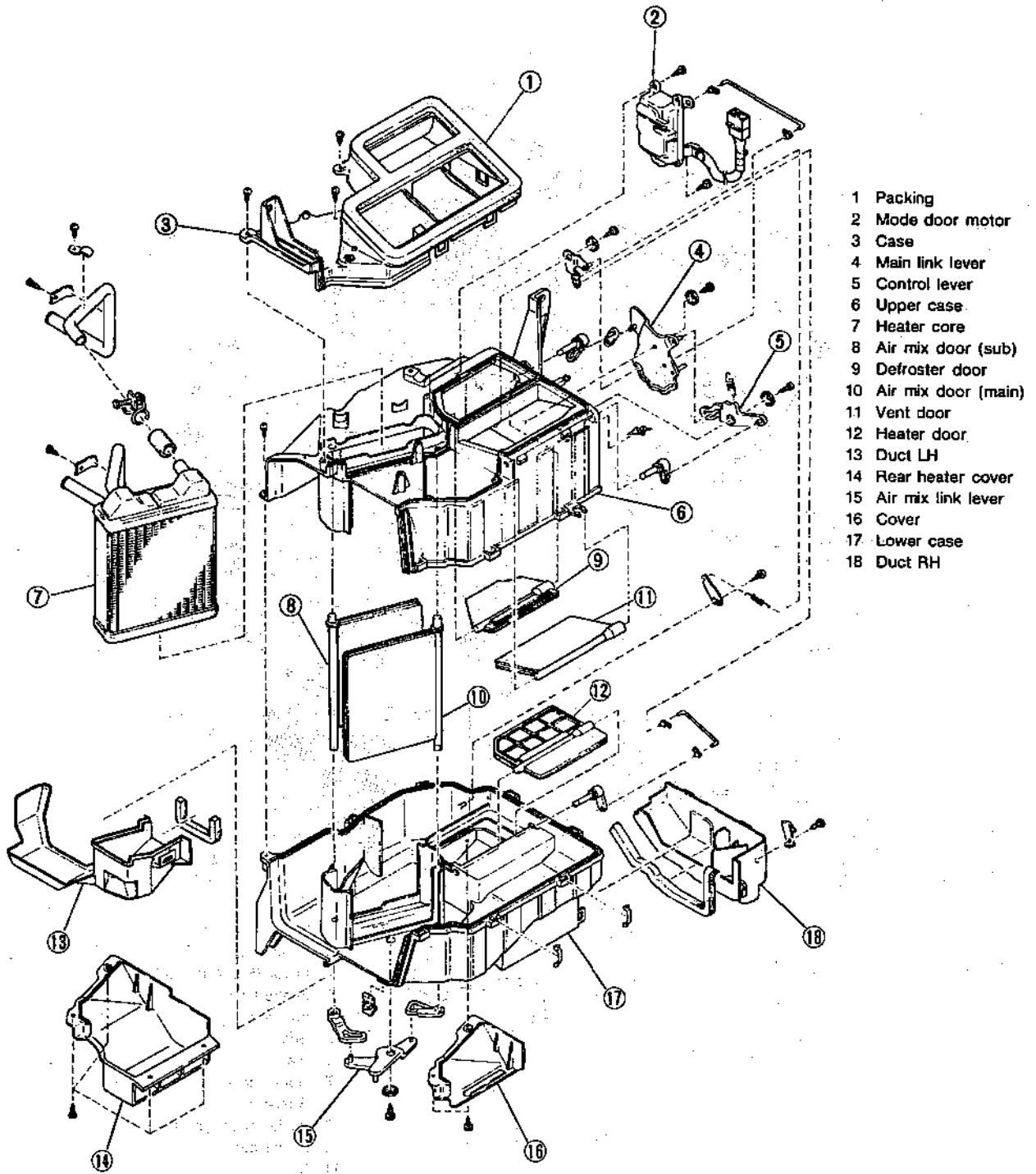


Fig. 14

B4-1538

3. Intake Unit

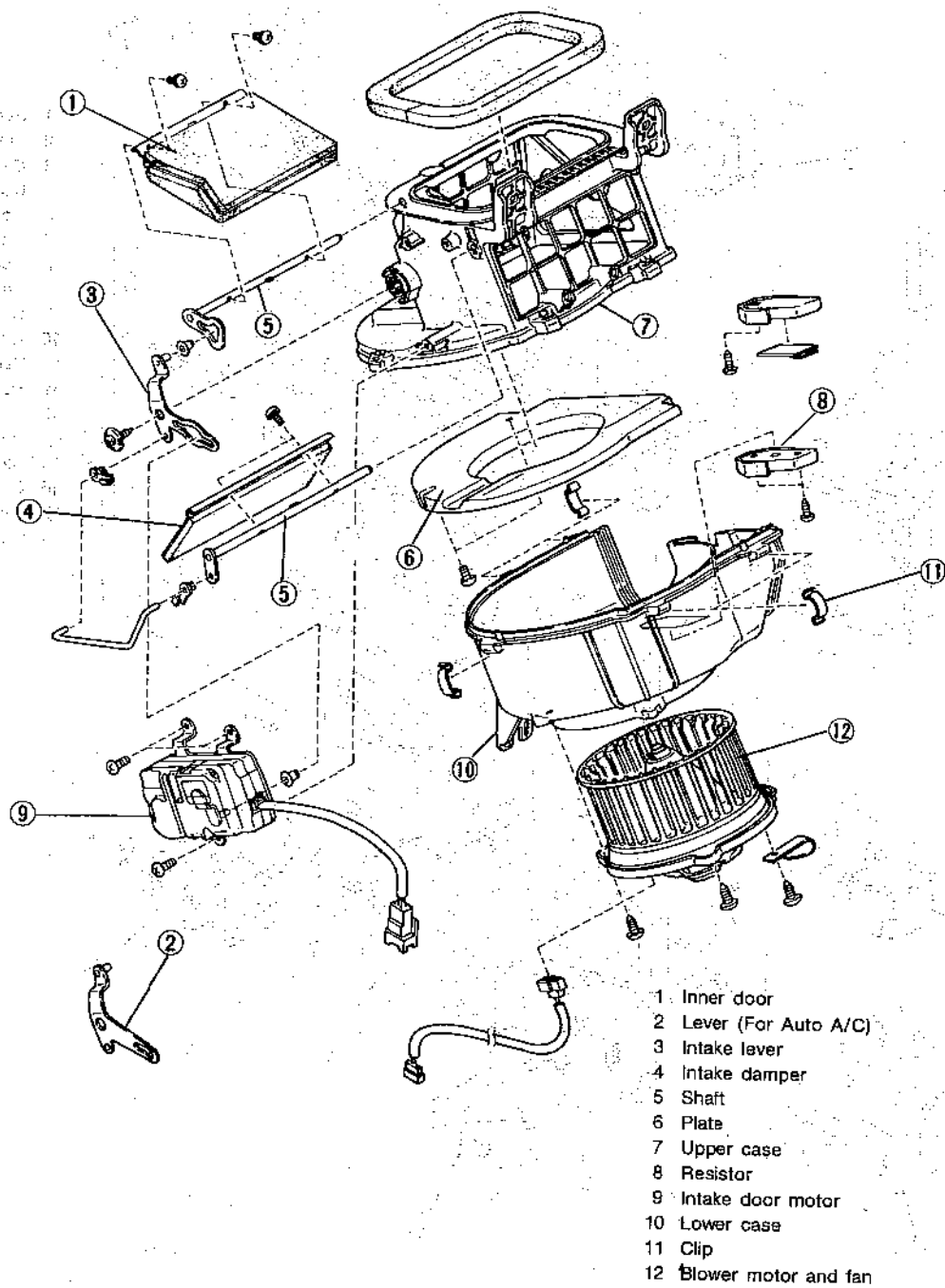


Fig. 15

B4-1564

4. Control Unit

1. PUSH CONTROL TYPE

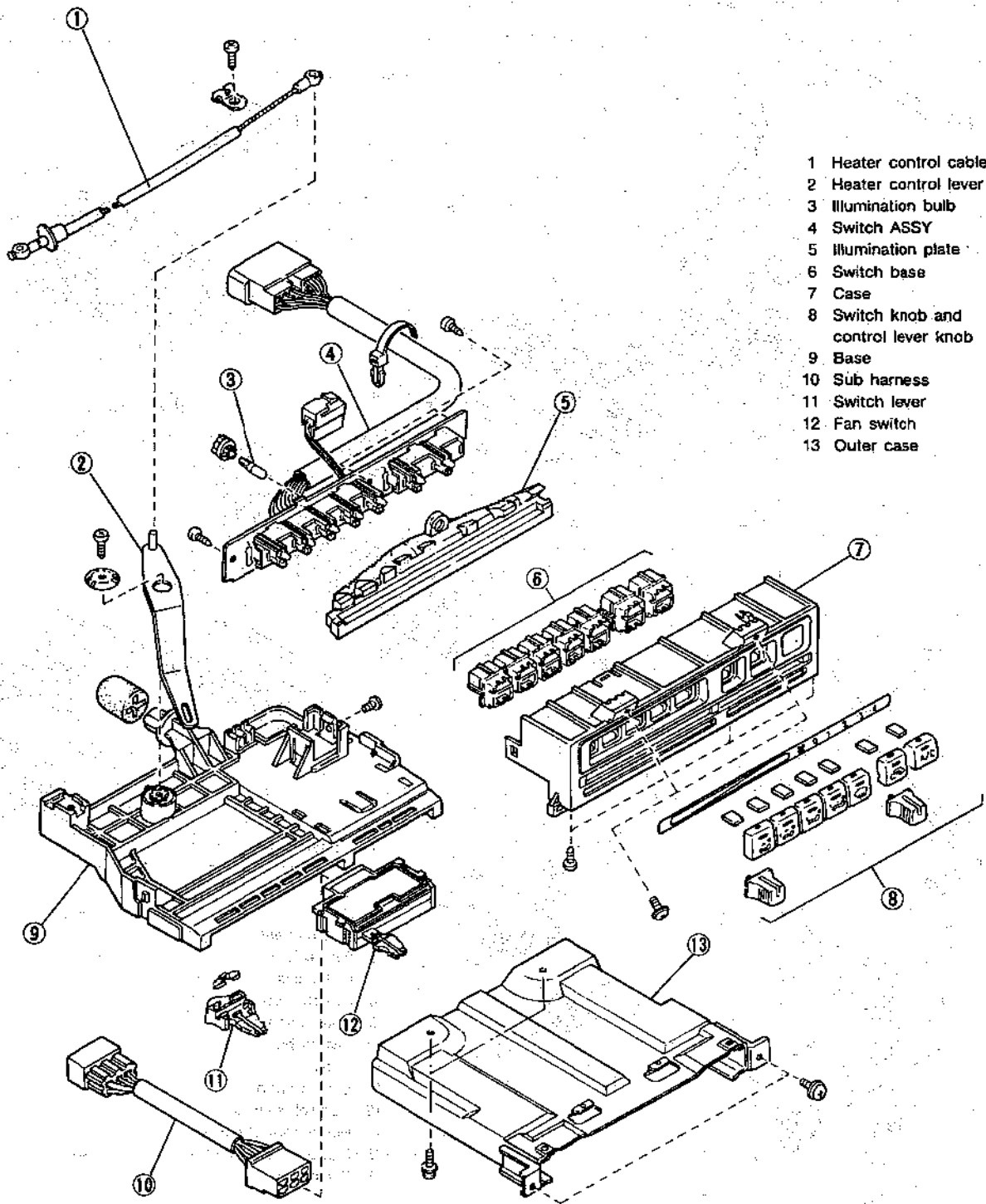


Fig. 16

B4-1539

W SERVICE PROCEDURE

1. Heater Unit

A: REMOVAL

1) Remove heater hoses (inlet, outlet) in engine compartment.

Drain as much coolant from heater unit as possible, and plug disconnected hose with cloth.

2) Disconnect temperature control cable and door motor joint connectors (mode, intake) from heater unit and intake unit.

3) Remove instrument panel and console box.
(Refer to 5-4.)

4) Remove cooling unit ASSY.
(Refer to 4-7.)

5) Remove heater duct.

6) Remove heater unit.

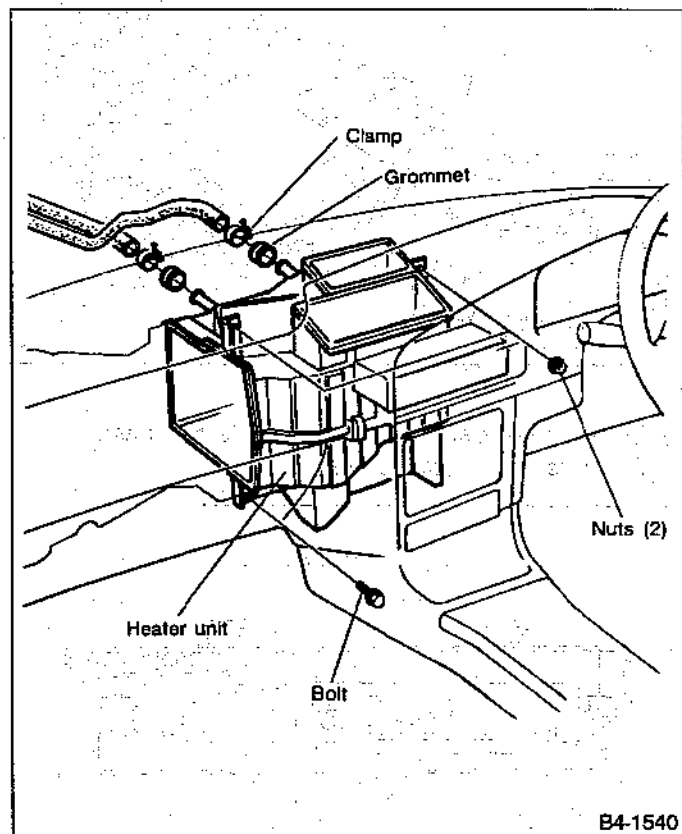


Fig. 18

B: INSTALLATION

Installation is in the reverse order of removal.

Fitted length of heater hose over pipe:
20 — 25 mm (0.79 — 0.98 in)

Heater unit mounting bolt tightening torque:
5.4 — 9.3 N·m (0.55 — 0.95 kg·m, 4.0 — 6.9 ft·lb)

2. Blower Motor Assembly

A: REMOVAL

1) Remove glove box and stay.

2) Remove heater duct. (or cooling unit for A/C equipped vehicles.)

3) Disconnect intake door motor harness connector.

4) Disconnect blower motor harness connector.

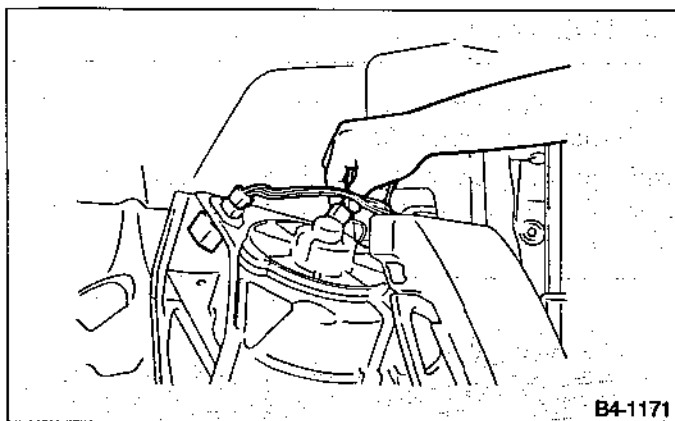


Fig. 19

5) Remove blower motor mounting bolts and nuts.

6) Remove blower motor assembly.

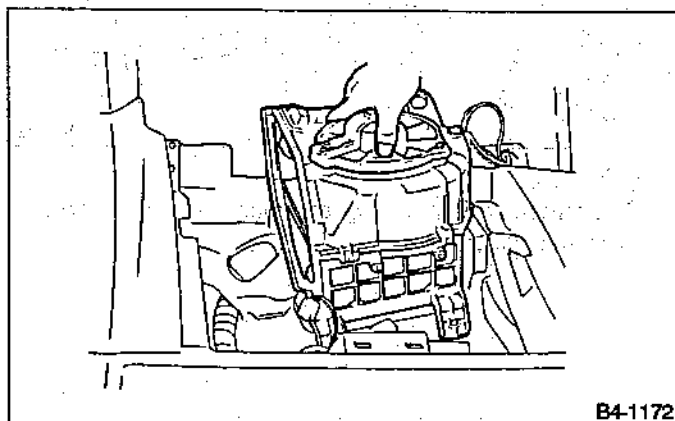


Fig. 20

3. Control Unit

A: REMOVAL

- 1) Remove temperature control cable from heater unit.
- 2) Remove visor A.
(Refer to chapter "INSTRUMENT PANEL".)
- 3) Disconnect push control unit harness connectors.
- 4) Remove push control unit assembly.

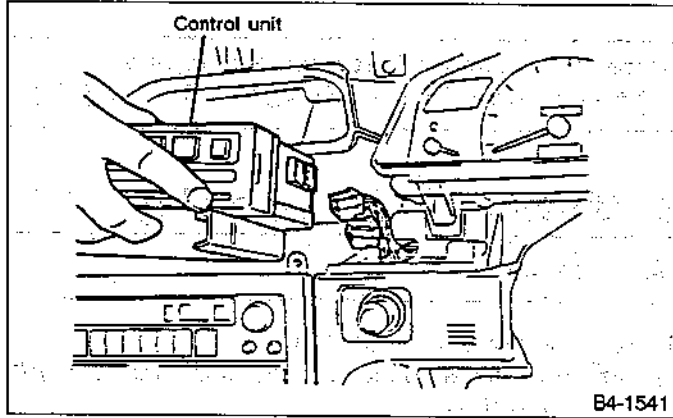


Fig. 21

B: DISASSEMBLY

- 1) Remove the two control knobs.
- 2) Remove the switch knobs.

While pushing the switch knob locking retainer with a pointed pin driver, remove switch knob in the direction of the arrow.

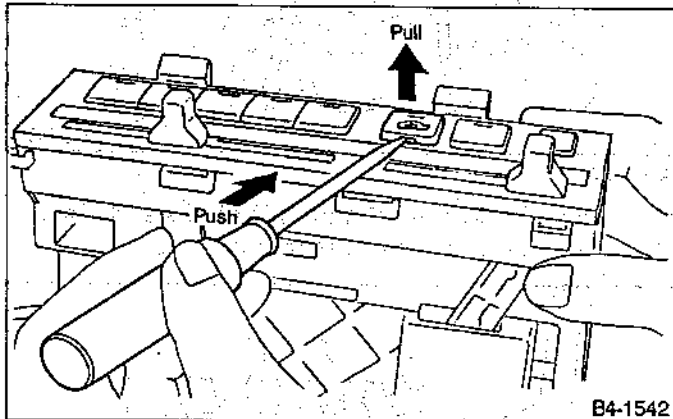


Fig. 22

- 3) Disconnect push control sub harness connector.
- 4) Remove control base.

Unfasten locks on each side of control base in the direction of the arrow, and remove control base from control box.

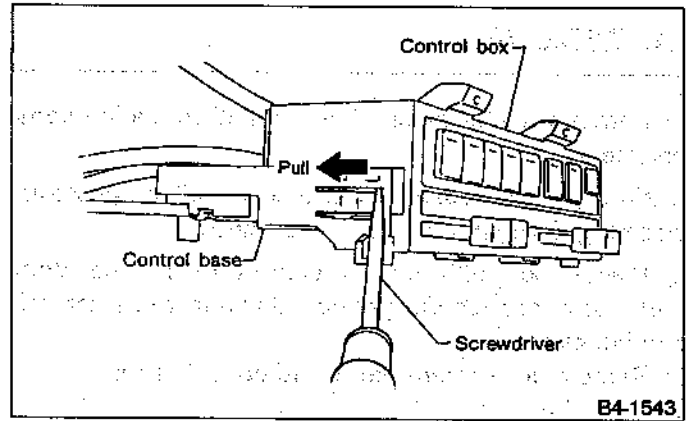


Fig. 23

- 5) Remove fan switch.

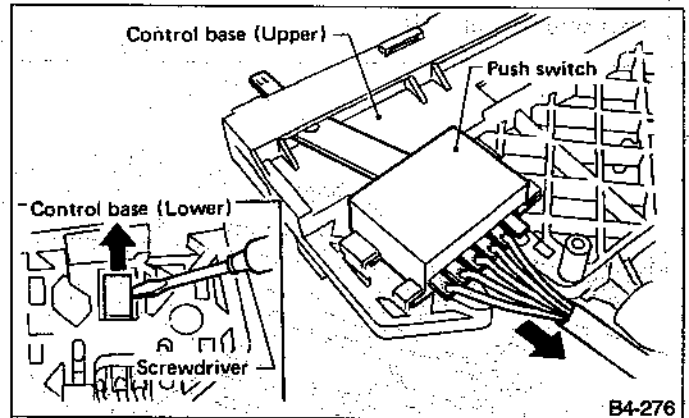


Fig. 24

- 6) Remove temperature control cable and lever.
- 7) Remove illumination bulbs.

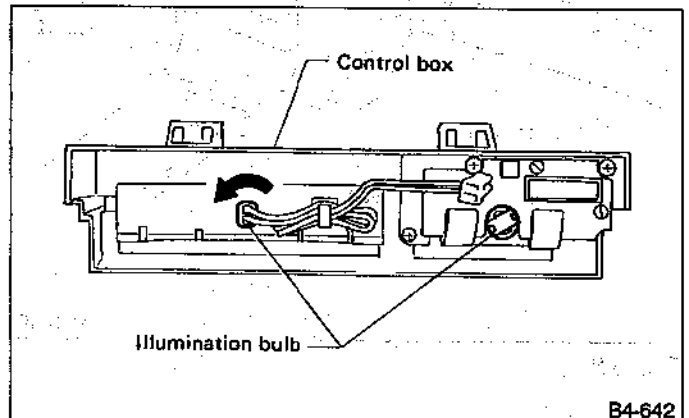


Fig. 25

C: INSPECTION

1. FAN SWITCH

Check continuity between terminals at each switch position:

Terminal No. / Switch position	1	2	4	5	3	6
OFF					○—○	
1				○—○	○—○	○—○
2			○—○	○—○	○—○	○—○
3		○—○	○—○	○—○	○—○	○—○
4	○—○	○—○	○—○	○—○	○—○	○—○

2. CONTROL UNIT

- 1) Ignition switch is turned OFF.
- 2) Disconnect connector from control unit.
- 3) Check circuit continuity between each terminal, when push control switch (mode, recirc switch) is turned ON.

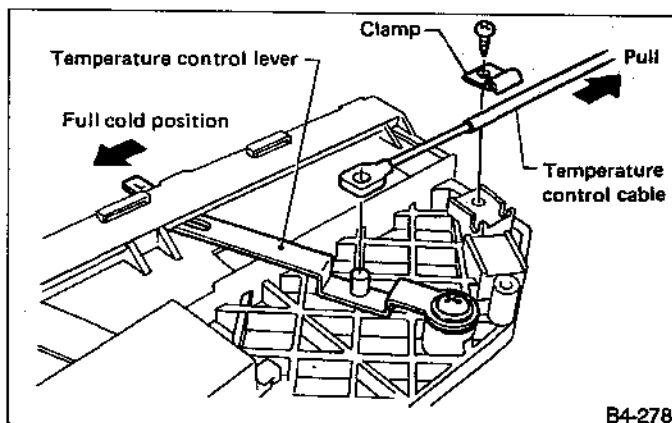
Terminal	Mode selector switch *2						RECIRC switch		A/C switch	L.E.D.		
	VENT	VENT HEAT	HEAT	HEAT DEF	DEF	OFF (switch canceled)	RECIRC	FRESH	ON	Mode selector switch *1	RECIRC switch *1	A/C switch
①						○						
②				○								
③			○									
④		○										
⑤	○					○						
⑥									○			
⑦									○			
⑧									○			
⑨	○	○	○	○	○	○	○	○	○	○	○	○
⑩										○	○	○
⑪										○	○	○
⑫										○	○	○
⑬										○	○	○

*1 Each switch (mode and recirc) is turned ON.

*2 Used only push control type.

D: ADJUSTMENT

- 1) Operate temperature control lever to "FULL COLD."
- 2) Install control cable to lever. While pulling outer cable, secure control cable with a clamp.



B4-278

Fig. 26

E: ASSEMBLY

Assembly is in the reverse order of disassembly.

F: INSTALLATION

Installation is in the reverse order of removal.
(Refer to 4-6 [W6A0].)

4. Mode Door Motor**A: REMOVAL**

- 1) Remove lower cover from instrument panel.
- 2) Disconnect mode door motor harness connector.
- 3) Remove screws which secure mode door motor to heater unit.
- 4) Using a screwdriver, remove rod holder.
- 5) While rotating mode door motor, remove it from rod holder.

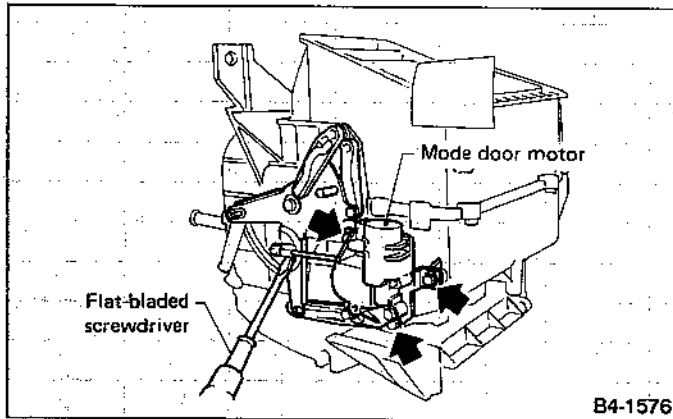


Fig. 27

Ensure mode select or switch is set to "VENT" (to set side link in the vent position) when removing mode door motor.

B: INSPECTION

- 1) Check the mode door motor operation. When approx. 12V is applied to the mode door motor terminals, mode door motor operates as follows.

	Terminal No.							Mode door motor position
	1	2	3	4	5	6	7	
Polarity of power supply					(-)	(+)	(-)	VENT
				(-)		(+)	(-)	BILEV
			(-)			(+)	(-)	HEAT
		(-)				(+)	(-)	HEAT/DEF
	(-)					(+)	(-)	DEF

C: INSTALLATION

- 1) Connect mode door motor to harness connector.
- 2) Turn ignition switch to "ACC" and set mode select or switch to "VENT".

Ensure that mode door motor is set in the vent mode.

- 3) Install mode door motor on heater unit.
- 4) Manually operate side link to the vent mode position, and secure rod to rod holder.
- 5) Set mode selector switch to "DEF", and ensure that side link moves over its full stroke range.

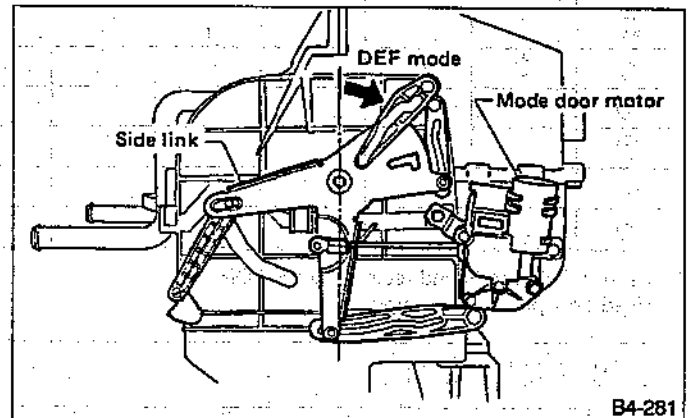


Fig. 28

5. Intake Door Motor

A: REMOVAL

- 1) Remove glove box.
- 2) Remove side cover from instrument panel.
- 3) Remove intake unit ASSY from the vehicle.
- 4) Remove screws which secure intake door motor to intake unit ASSY.

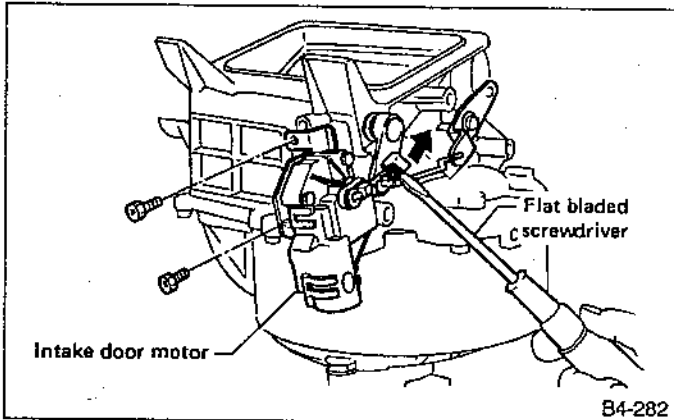


Fig. 29

- 5) Remove intake door motor and harness as a unit.
- 6) Disconnect harness from intake motor.

Ensure that RECIRC switch is set to "ON".

B: INSPECTION

When approx. 12V is applied to the intake door motor terminals, intake door motor operates as follows.

Intake door motor position	Terminal		Intake door motor operation
	⊕	⊖	
Fresh	①	③	Door motor moved to Recirc position
Recirc	①	②	Door motor moved to Fresh position

C: INSTALLATION

- 1) Connect harness to intake door motor.
- 2) Turn ignition switch to "ACC" and set RECIRC switch to "ON" switch to "RECIRC".

Ensure that intake door motor is set in the "RECIRC" mode.

- 3) Install intake door motor on intake unit.
- 4) Secure rod holder to link, and install link to intake unit ASSY.
- 5) Manually set rod in the "RECIRC" mode, and secure to rod holder.

- 6) Operate mode selector switch to ensure that system changes from intake air to "RECIRC" and from "RECIRC" to intake air in full-stroke range.

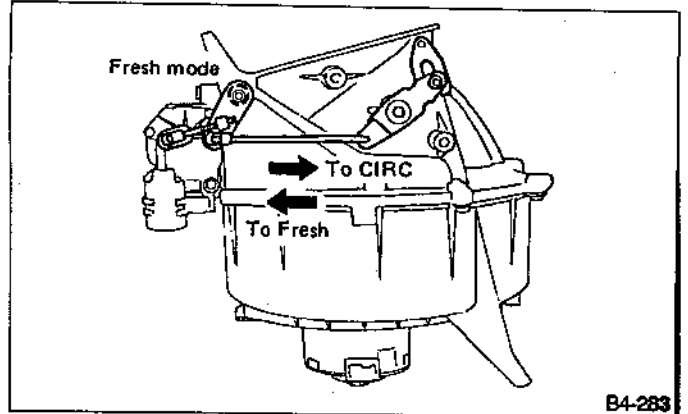


Fig. 30

6. Temperature Control Cable

A: ADJUSTMENT

- 1) Operate temperature control lever to "FULL COLD".
- 2) Connect control cable to air mix door link.
- 3) While pushing outer cable in the direction of the arrow, secure control cable to clamp.

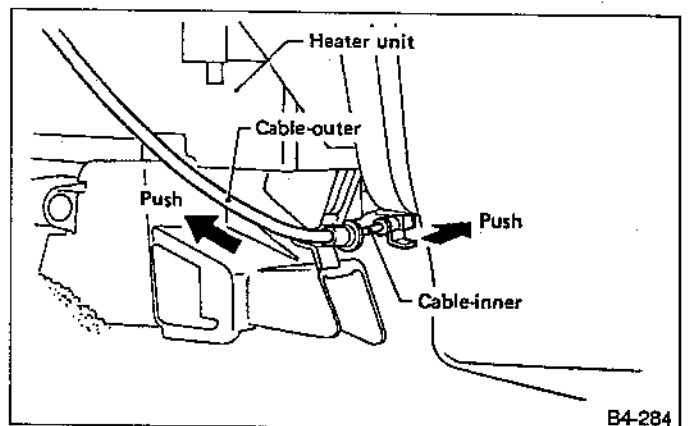


Fig. 31

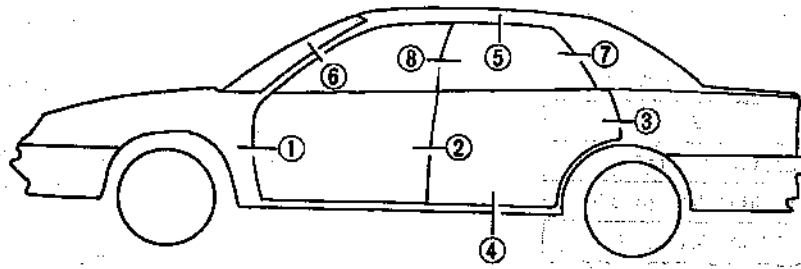
- 4) Operate temperature control lever to ensure that it and air mix door link complete their full stroke ranges. (Refer to 4-6.)



Publication No. G205AE ④
Issued: September 1991 A
Printed in Japan M-0.25

SERVICE DATA

1. DOOR ALIGNMENT



Unit: mm (in)

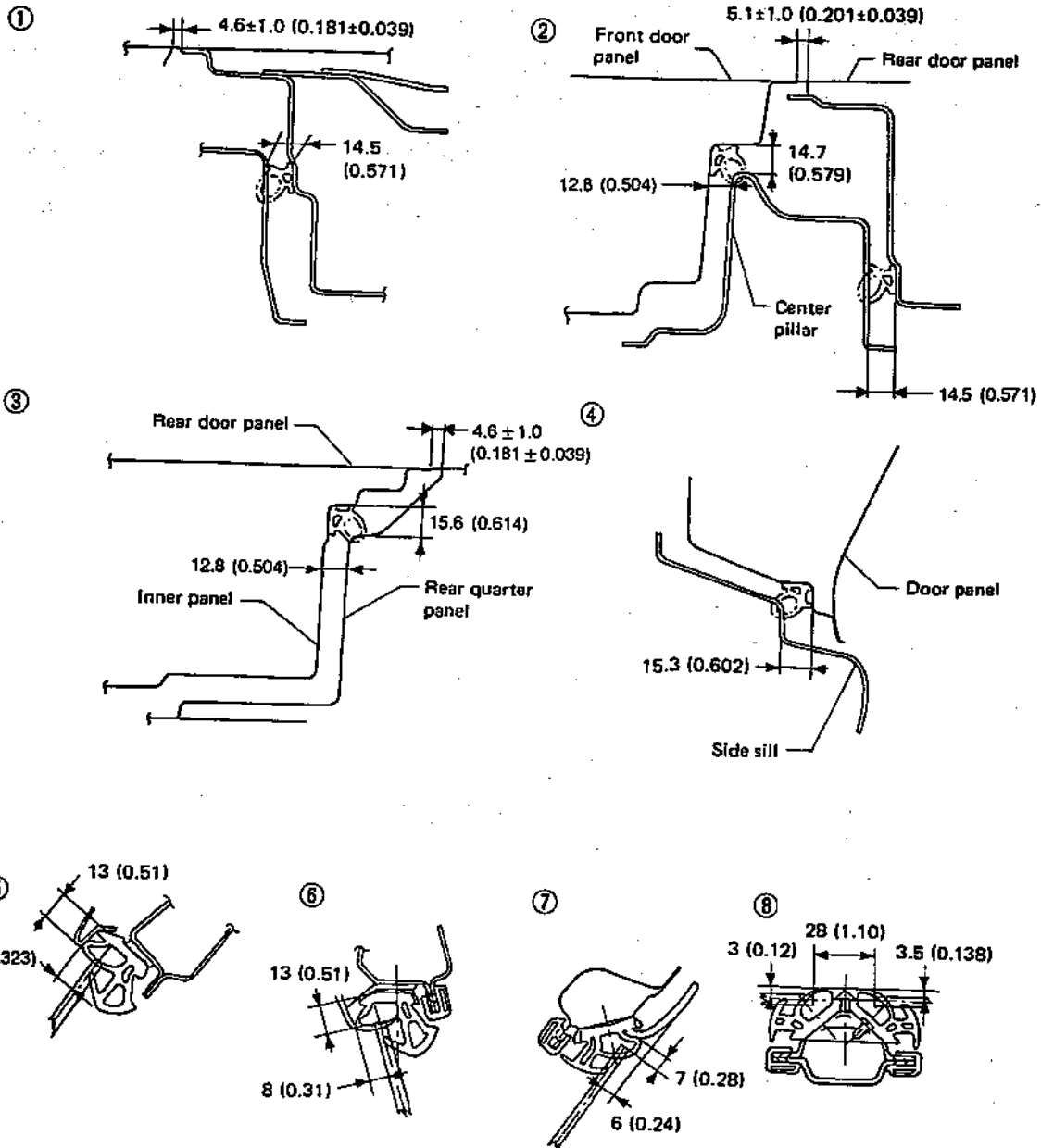
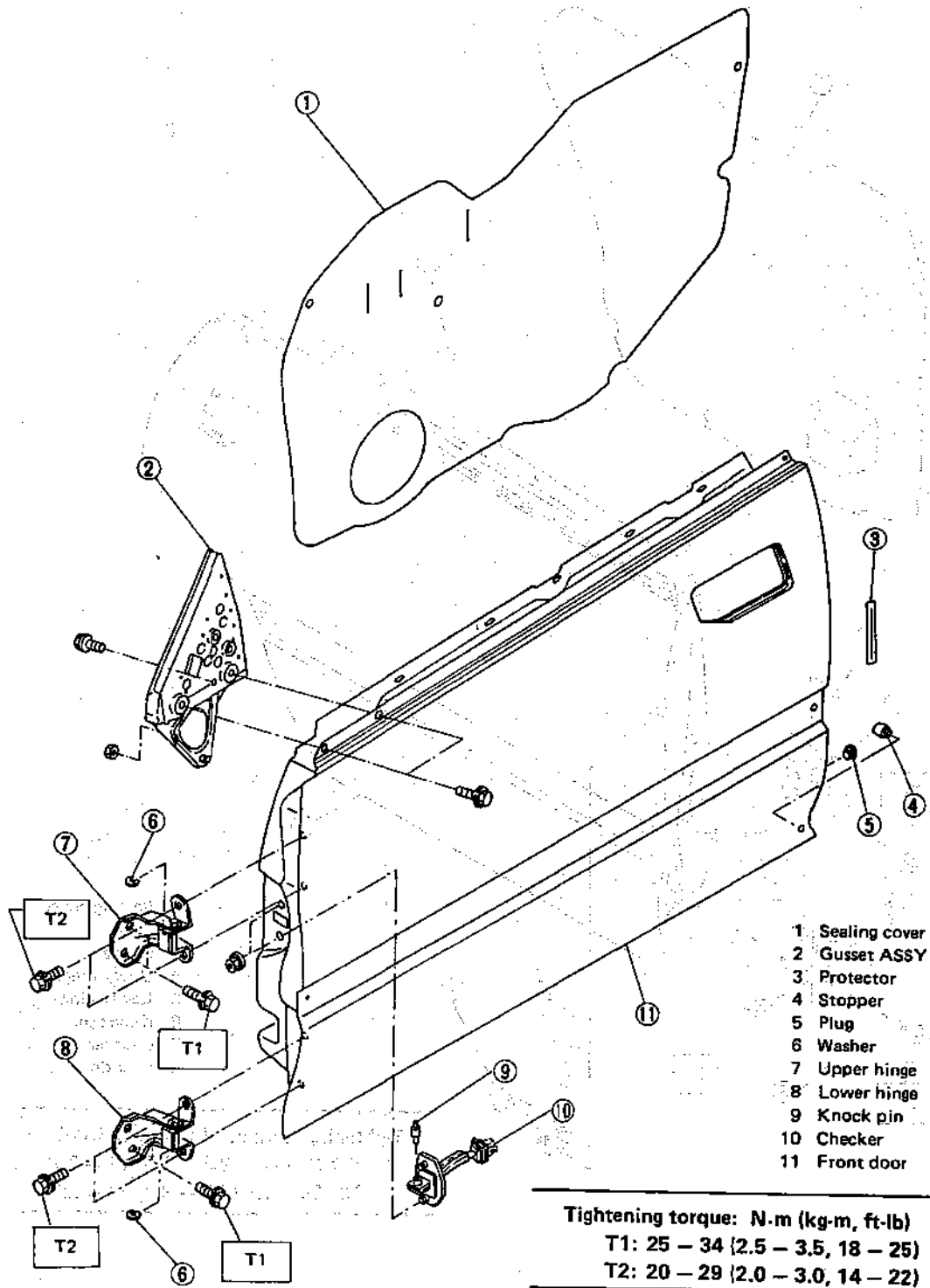


Fig. 11

B5-166

C COMPONENT PARTS

1. Front Door



- 1 Sealing cover
- 2 Gusset ASSY
- 3 Protector
- 4 Stopper
- 5 Plug
- 6 Washer
- 7 Upper hinge
- 8 Lower hinge
- 9 Knock pin
- 10 Checker
- 11 Front door

Tightening torque: N-m (kg-m, ft-lb)
T1: 25 - 34 (2.5 - 3.5, 18 - 25)
T2: 20 - 29 (2.0 - 3.0, 14 - 22)

Fig. 12

DOOR

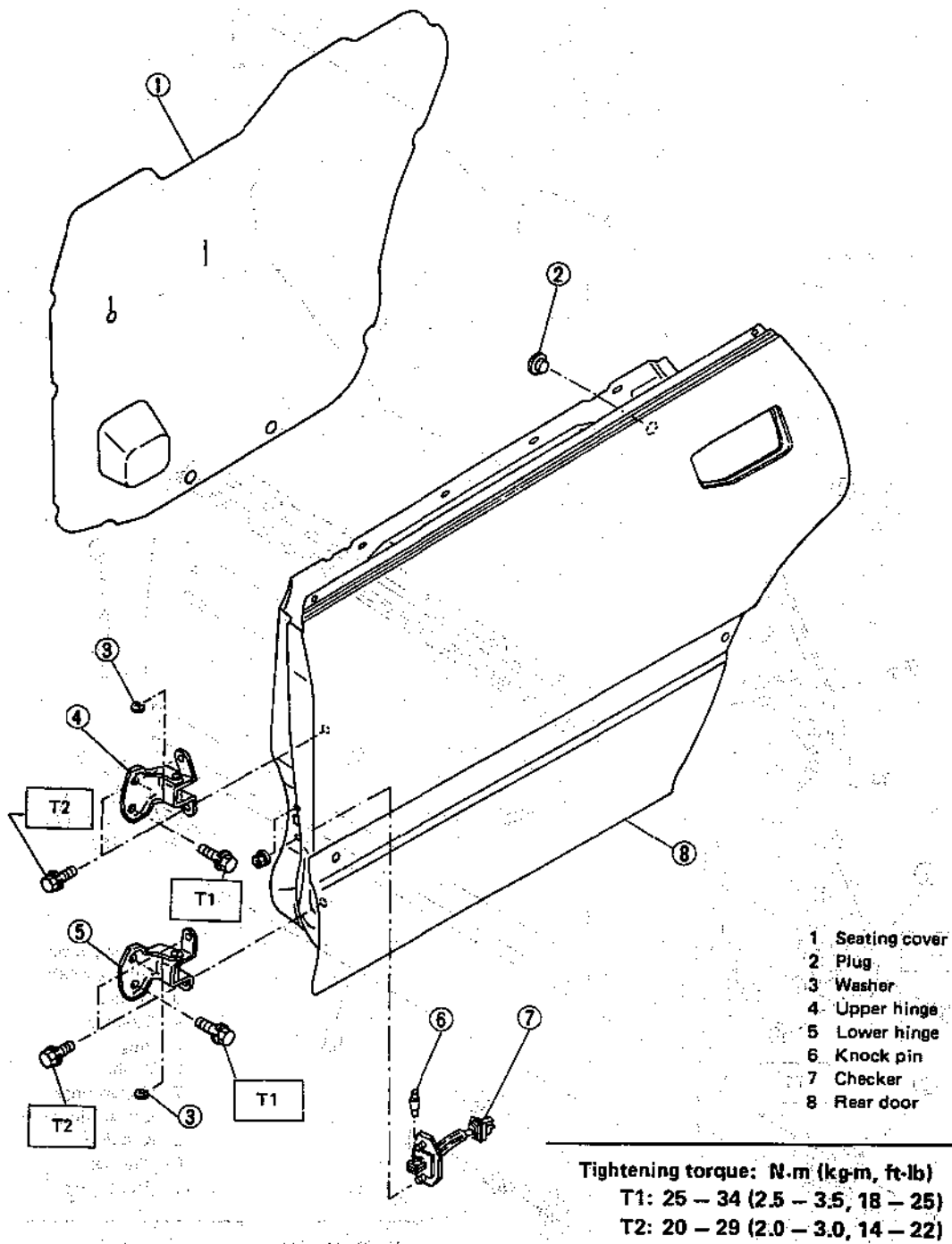


Fig. 13

B5-1023

3. Front Door Glass

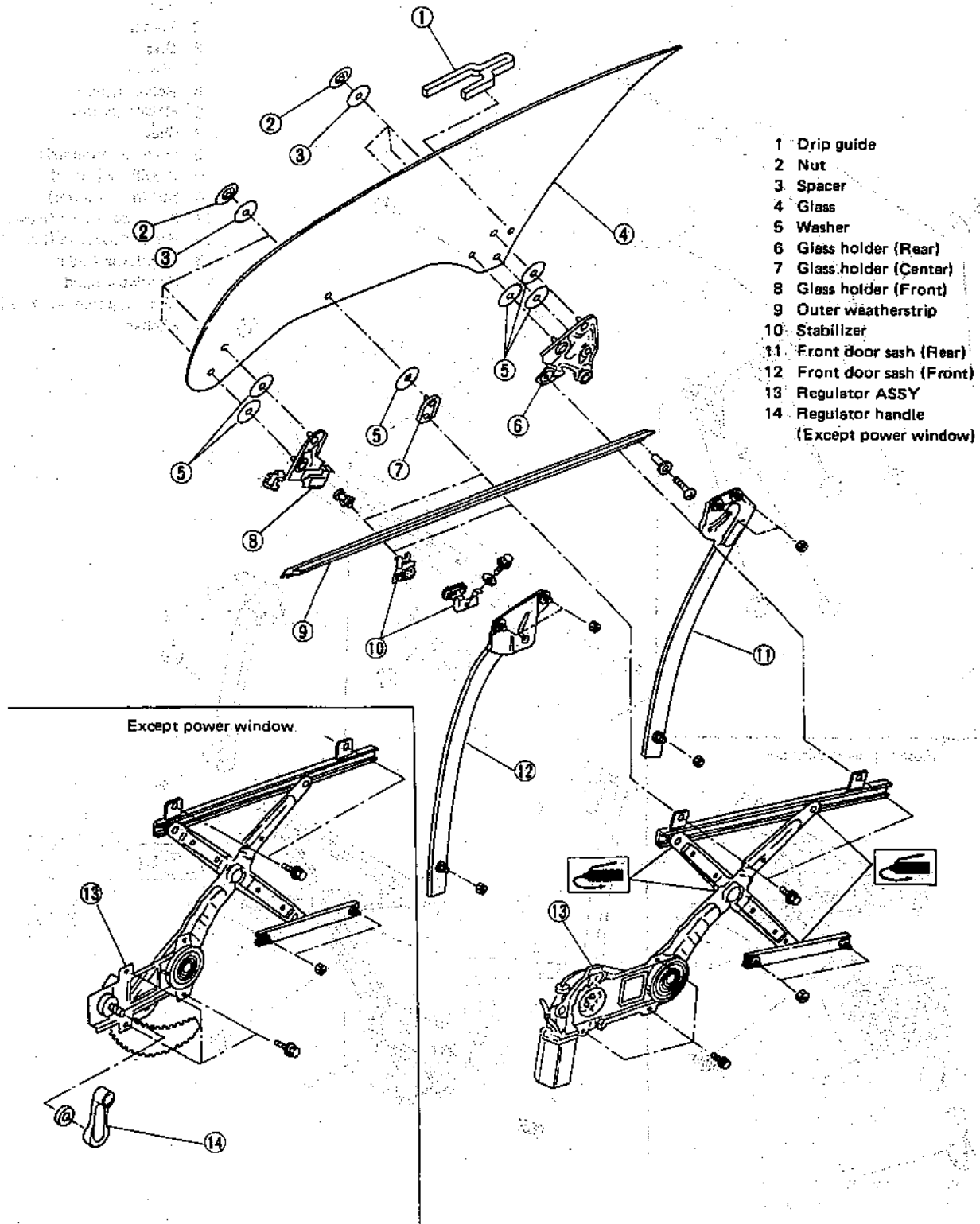


Fig. 14

B5-1024-1

Door Glass

Illustration of the door glass assembly showing the front and rear views of the door sash and the regulator assembly.

- 1 Nut
- 2 Spacer
- 3 Glass
- 4 Washer
- 5 Holder (Rear)
- 6 Holder (Front)
- 7 Slider
- 8 Outer weatherstrip
- 9 Stabilizer (Inner)
- 10 Stabilizer (Outer)
- 11 Front door sash (Rear)
- 12 Front door sash (Front)
- 13 Regulator ASSY
- 14 Regulator handle (Except power window)
- 15 Washer

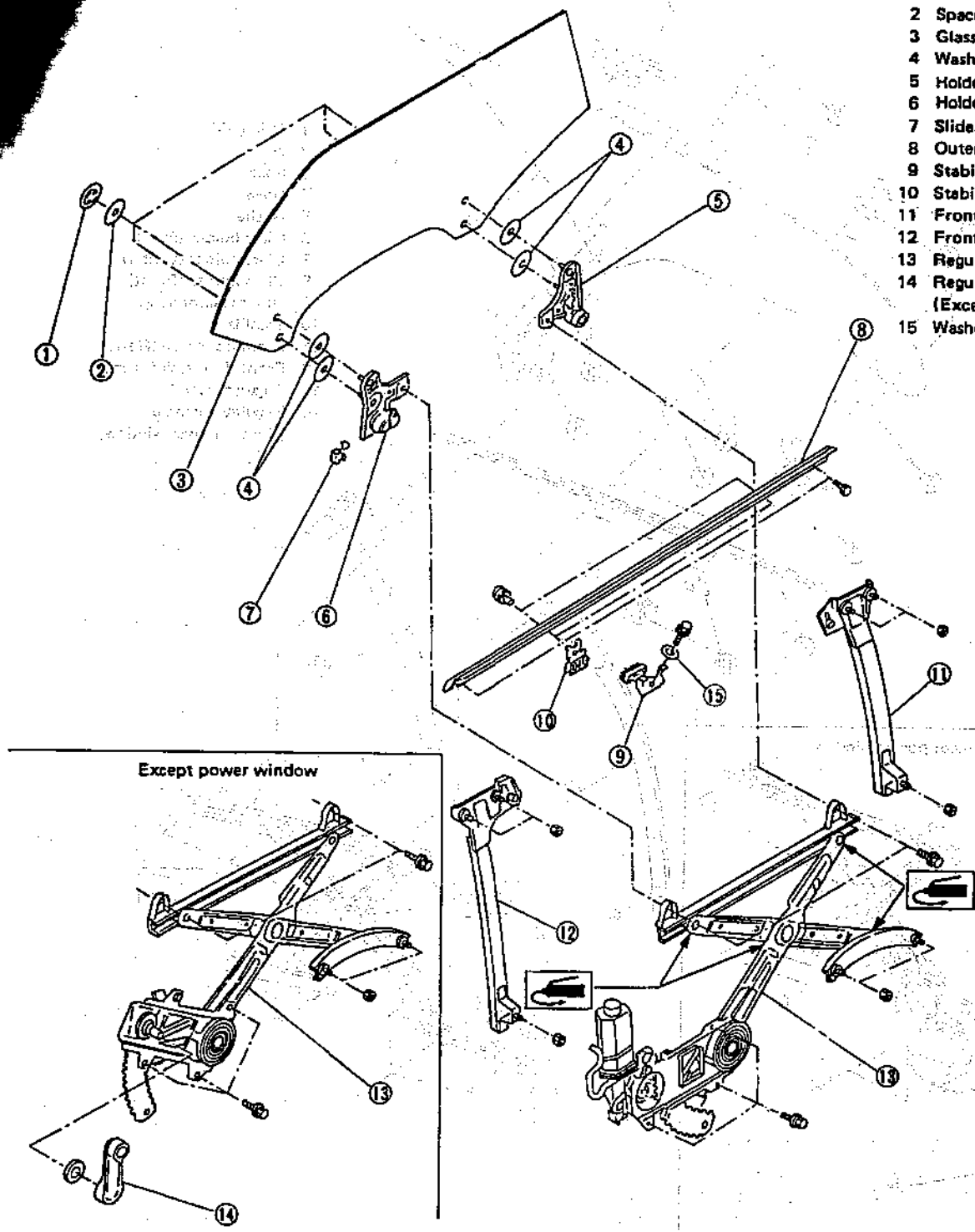


Fig. 15

B5-547

5. Rear Gate and Glass

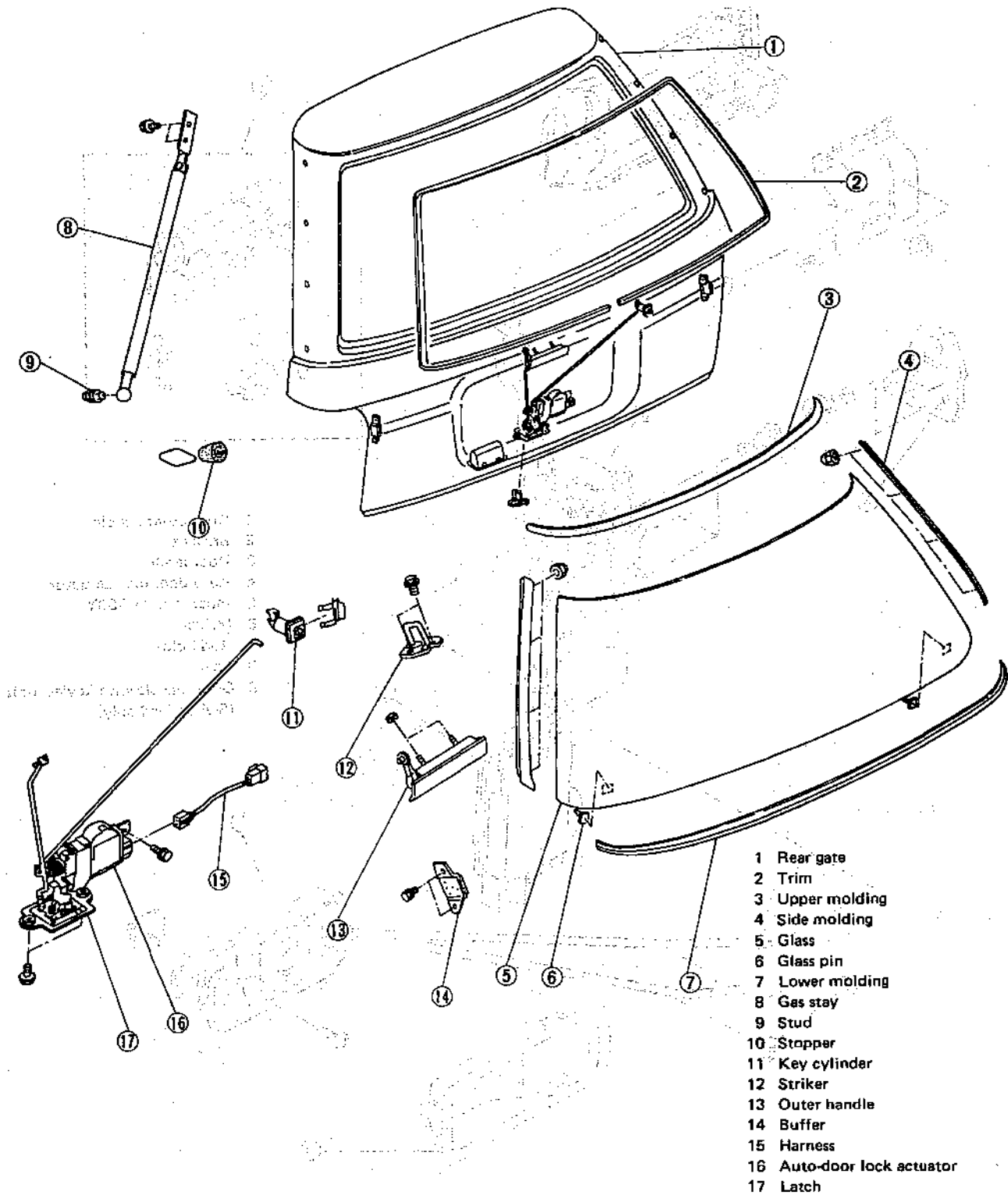
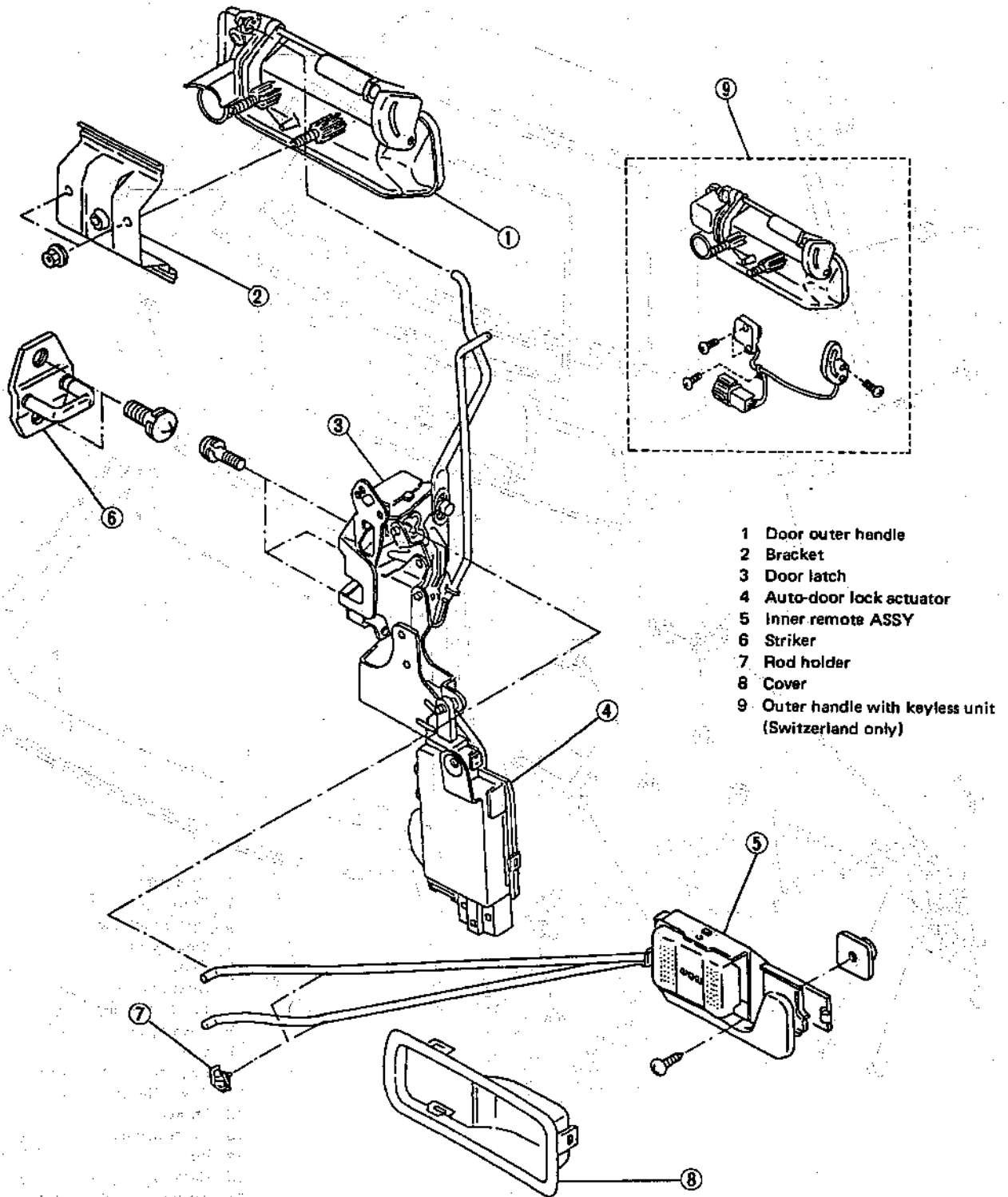


Fig. 16

B5-1025

Lock Assembly (Front)



- 1 Door outer handle
- 2 Bracket
- 3 Door latch
- 4 Auto-door lock actuator
- 5 Inner remote ASSY
- 6 Striker
- 7 Rod holder
- 8 Cover
- 9 Outer handle with keyless unit (Switzerland only)

Fig. 17

B5-601

7. Door Lock Assembly (Rear)

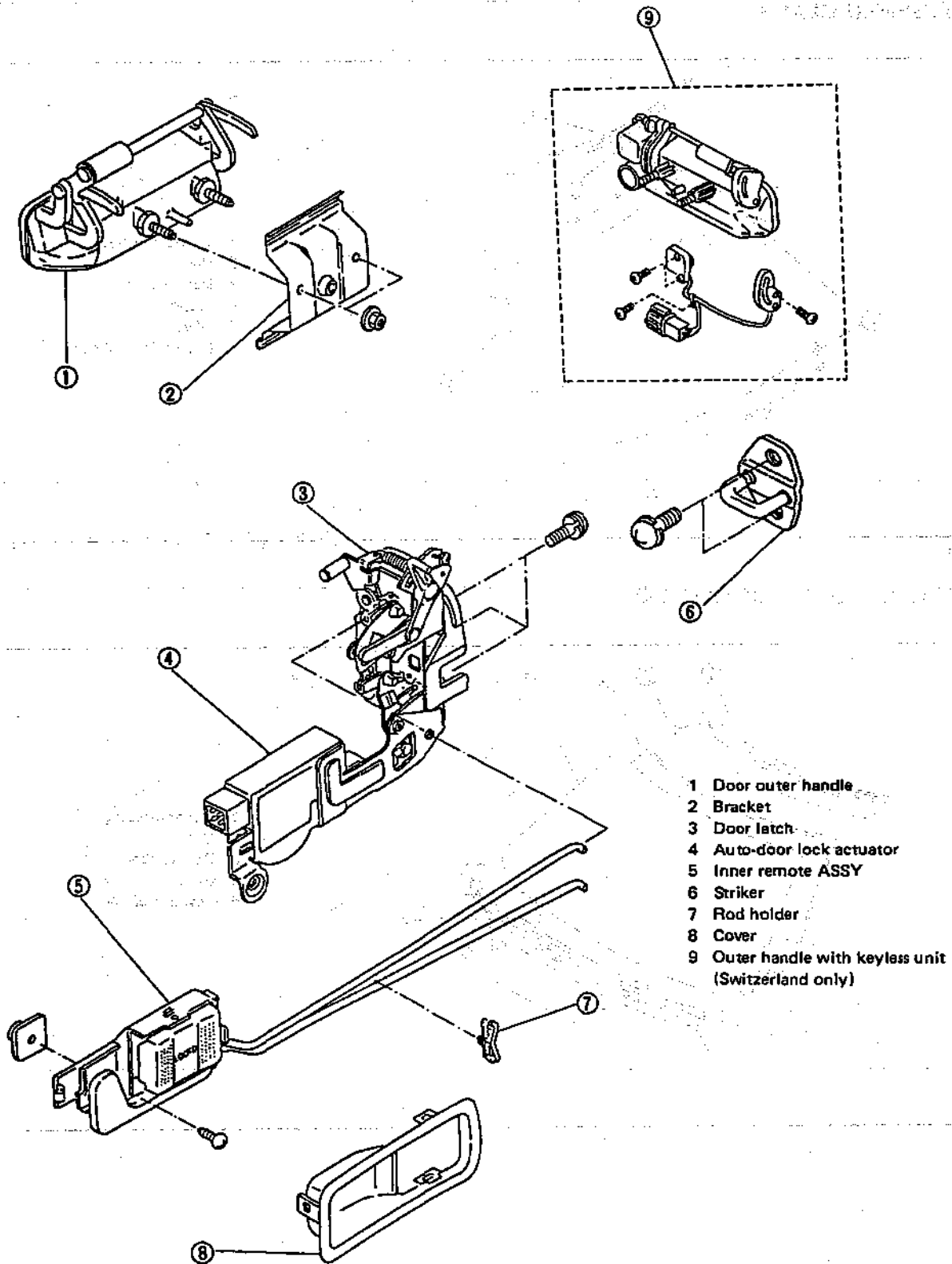
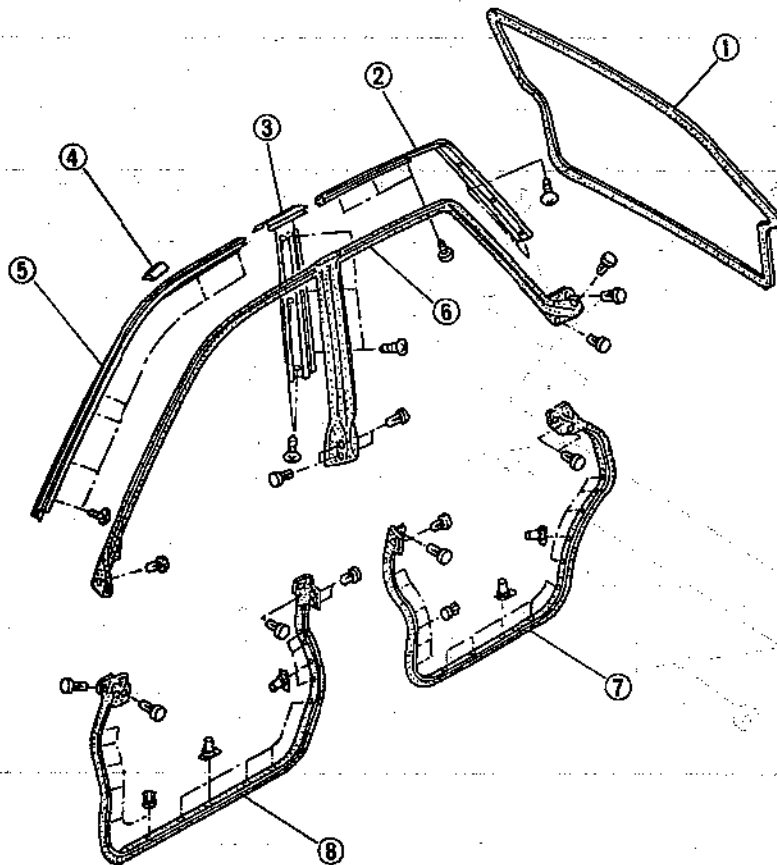
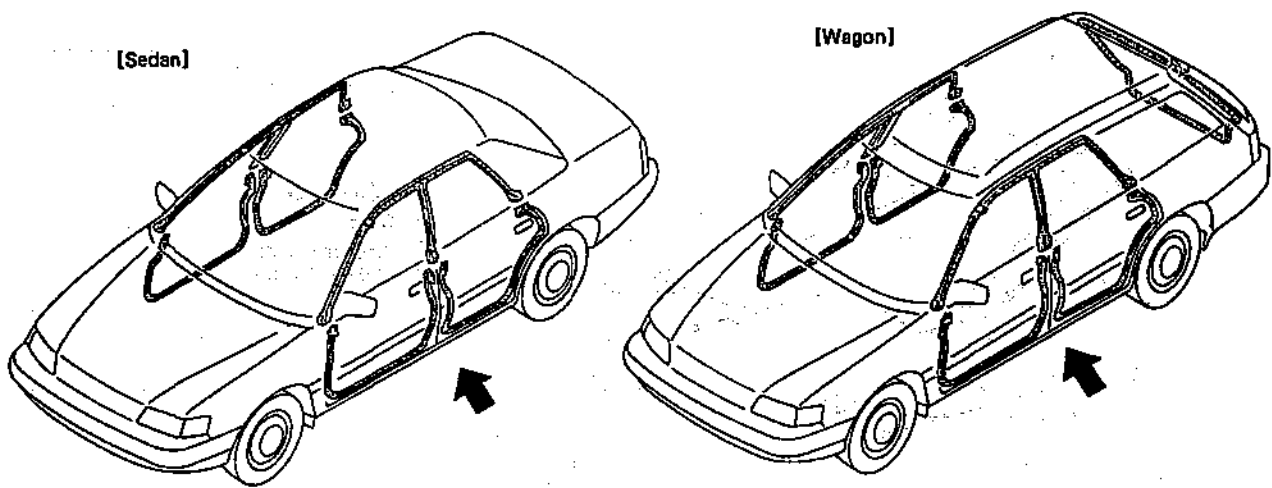


Fig. 18

B5-602

9. Weatherstrip



- 1 Rear gate weatherstrip
(Station Wagon only)
- 2 Upper retainer (Rear)
- 3 Upper retainer (Center)
- 4 Clip
- 5 Upper door retainer (Front)
- 6 Upper and side weatherstrip
- 7 Lower weatherstrip (Rear)
- 8 Lower weatherstrip (Front)

Fig. 23

B5-361

10. Garnish

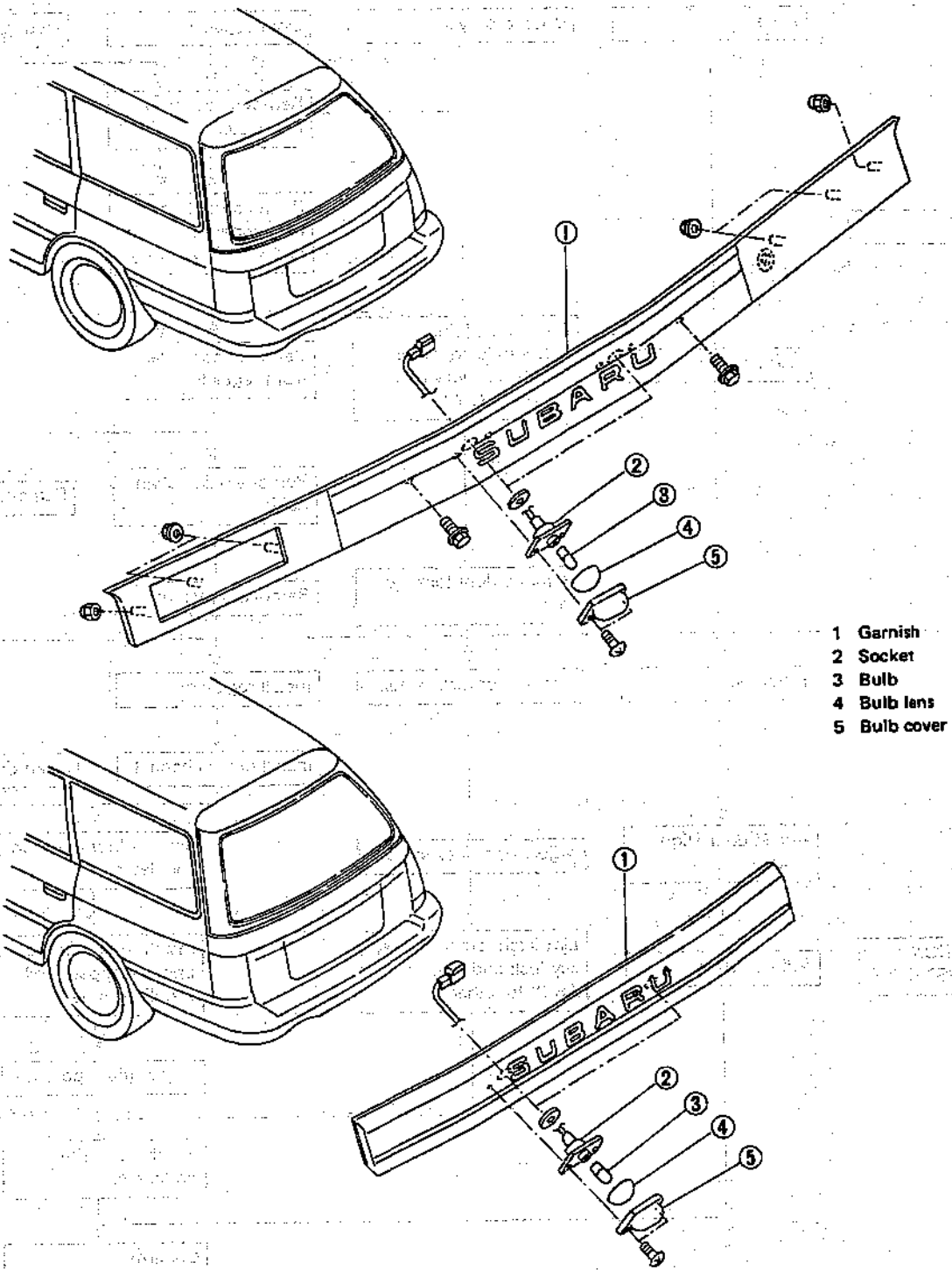
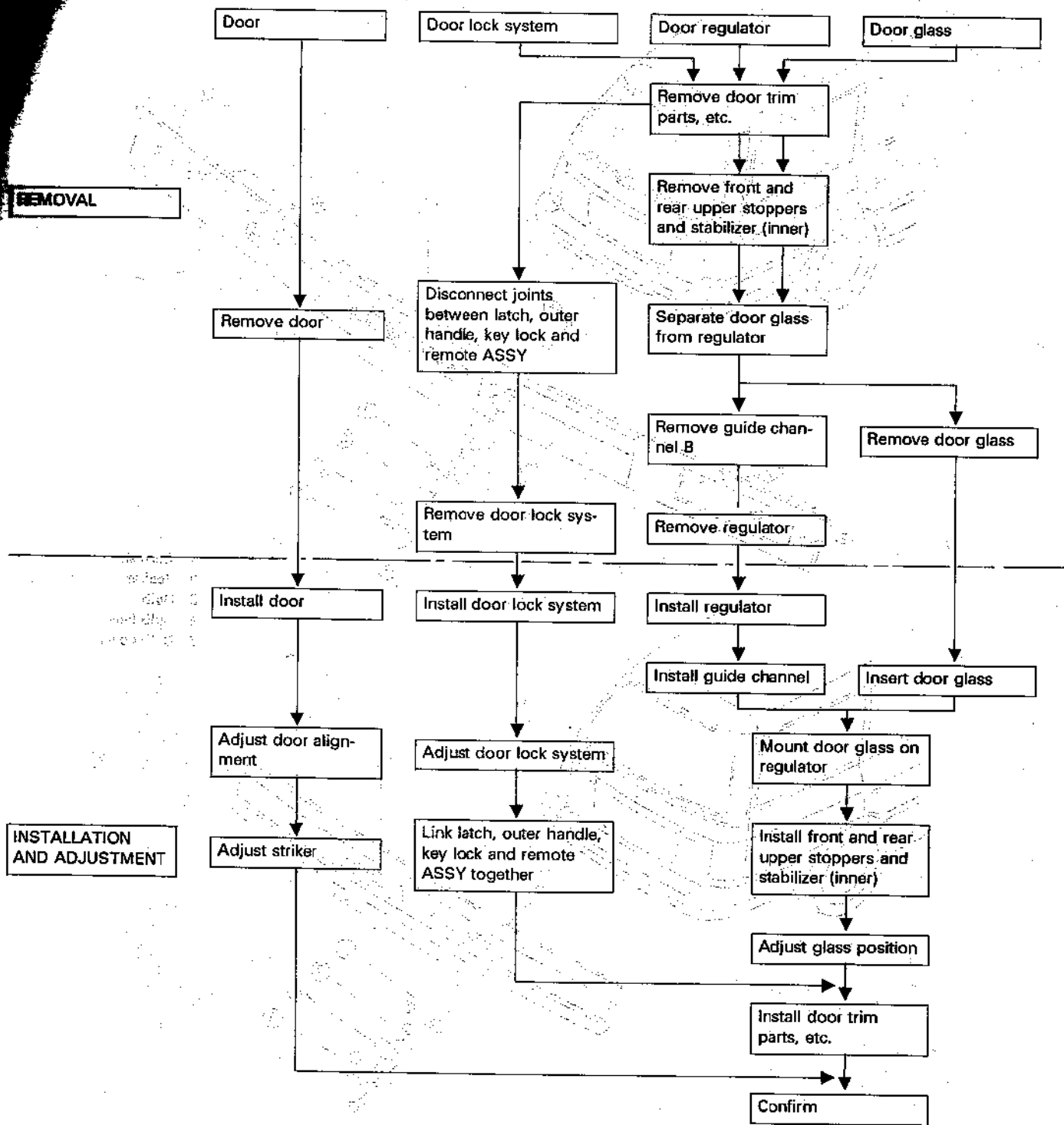


Fig. 24

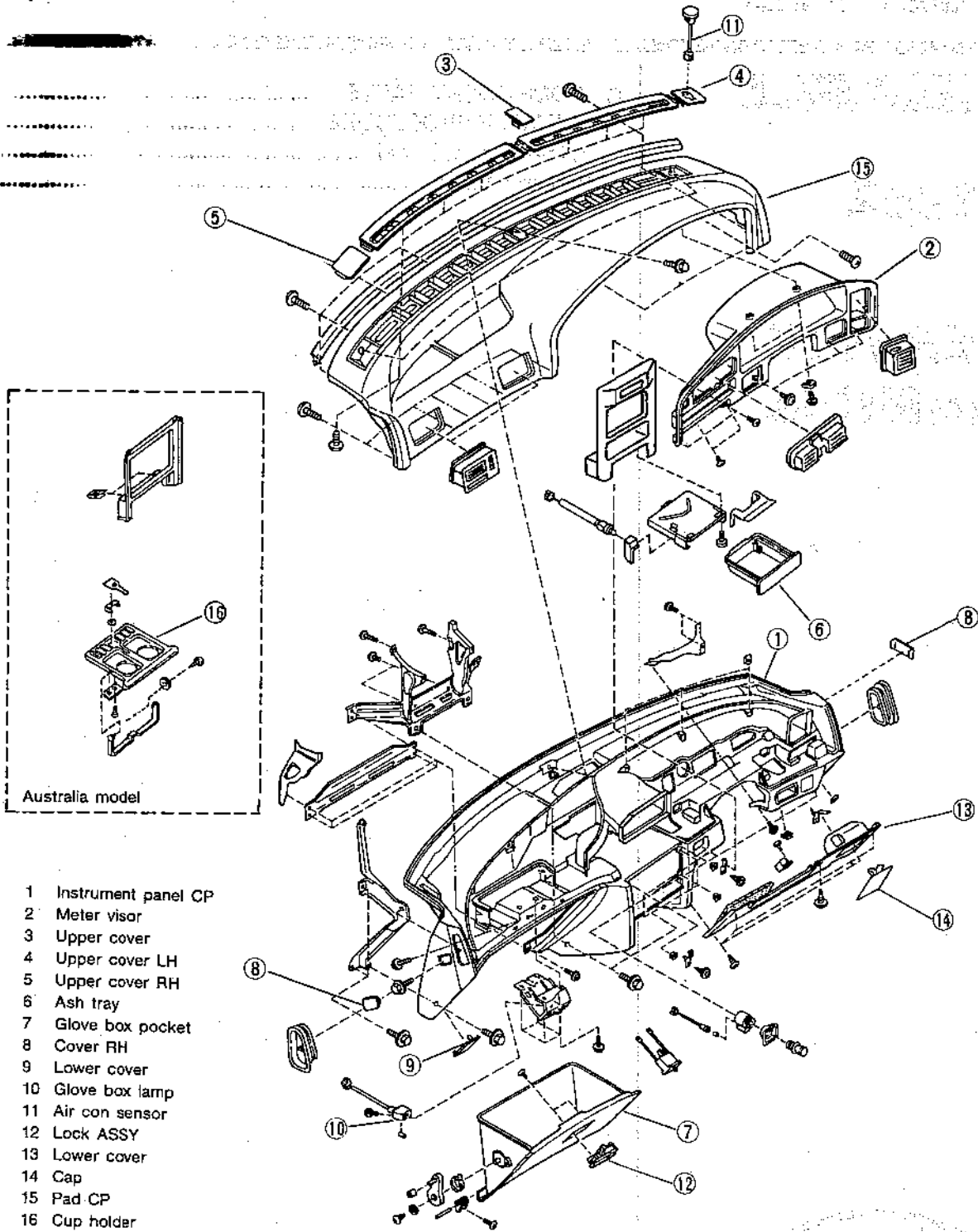
SERVICE PROCEDURE

Procedure Chart of Removing and Installing Door and Related



This flowchart shows the main procedures for removing and installing the door and its related parts. For details, refer to text.

C COMPONENT PARTS



- 1 Instrument panel CP
- 2 Meter visor
- 3 Upper cover
- 4 Upper cover LH
- 5 Upper cover RH
- 6 Ash tray
- 7 Glove box pocket
- 8 Cover RH
- 9 Lower cover
- 10 Glove box lamp
- 11 Air con sensor
- 12 Lock ASSY
- 13 Lower cover
- 14 Cap
- 15 Pad CP
- 16 Cup holder

Fig. 1

B5-1175

W SERVICE PROCEDURE

1. Instrument Panel

A: REMOVAL

- 1) Disconnect ground cable from battery.
- 2) Remove center console box.

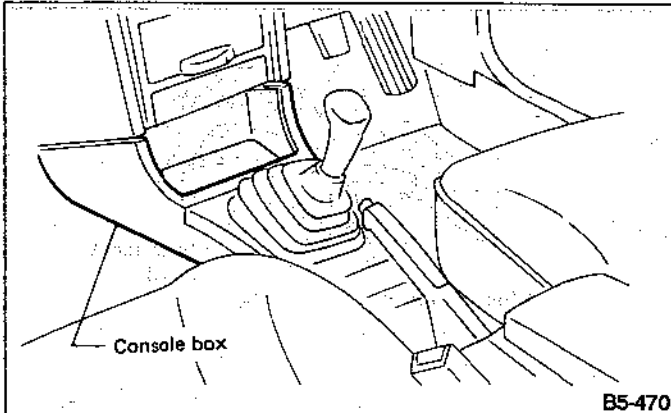


Fig. 2

- 3) Remove instrument panel covers.
 - (1) Remove three upper covers with a screwdriver.
 - (2) Remove both side covers with a screwdriver.
 - (3) Remove lower passenger side cover with a screwdriver.

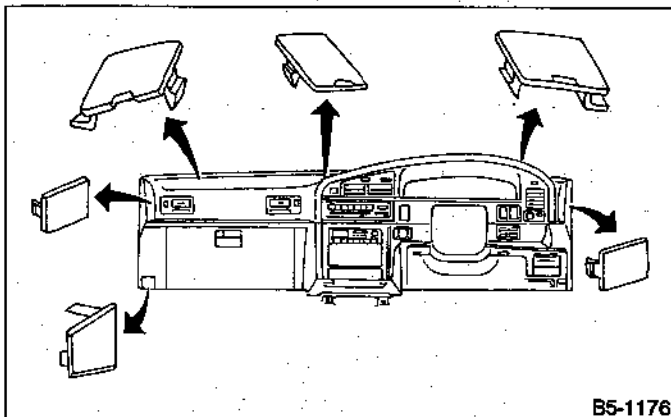


Fig. 3

- 4) Remove front pillar lower trim panel from the body.
- 5) Remove front hood cable from the front hood.
- 6) Disconnect harness connectors.
 - a. Be sure to hold socket section when disconnecting, not harness.
 - b. Put matching mark, if necessary, for easy re-assembly.
- 7) Disconnect speedometer cable from rear side of combination meter.
- 8) Disconnect blower switch harness connector.

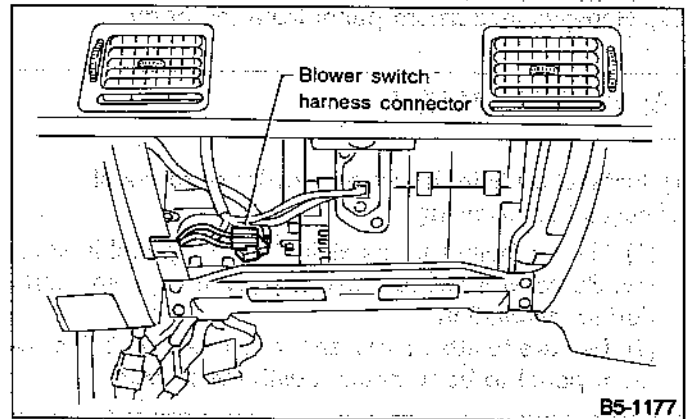


Fig. 4

- 9) Disconnect ventilation cable from heater unit.
- 10) Disconnect radio antenna feeder.
- 11) Disconnect temperature control cable from heater unit.
- 12) Disconnect connector from fuse box.
- 13) Remove lower cover on driver's side.

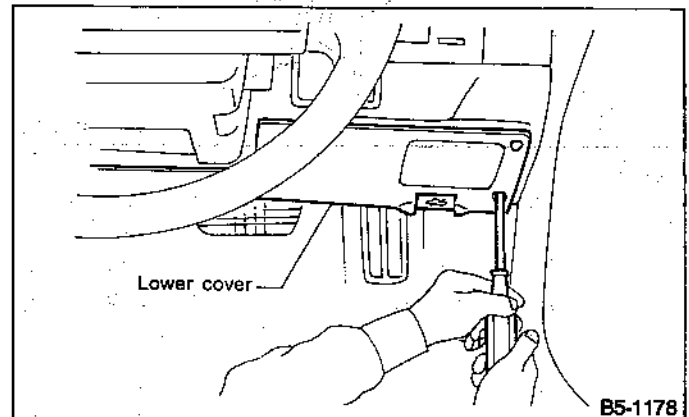


Fig. 5

- 14) Remove bolts which secure steering system.
- 15) Remove bolts holding instrument panel in place.

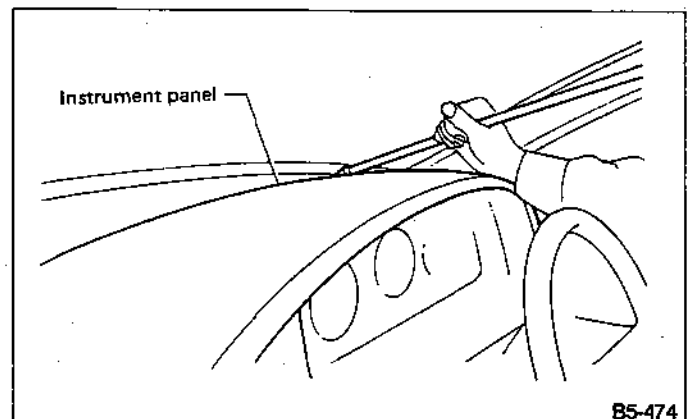


Fig. 6

Instrument panel is supported by center bracket and will not fall even when all bolts are removed.

16) Disconnect blower motor vacuum hose at upper ~~opposite~~ side of pocket frame.

17) Remove instrument panel from the body.

B: INSTALLATION

1) Installation is in the reverse order of removal. Observe the following:

(1) Have a helper to install instrument panel in vehicle. Be careful not to strike it against adjacent parts during installation.

(2) Be sure to attach forward center section of instrument panel to body bracket with the helper.

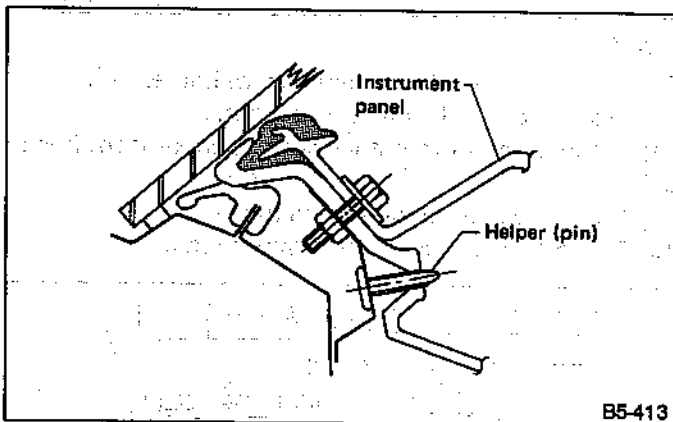


Fig. 7

(3) While setting instrument panel in position, be careful not to obstruct air outlets of heater and blower with harness connectors, cables of vacuum hoses. Also, do not allow them to be caught between bracket and instrument panel.

(4) Be sure to place forward end of instrument panel on top of weatherstrip located at lower side of windshield. Do not fold up weatherstrip.

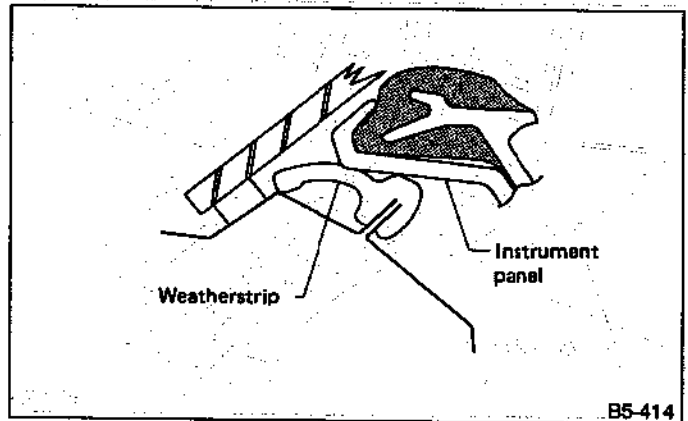


Fig. 8

2. Meter Visor

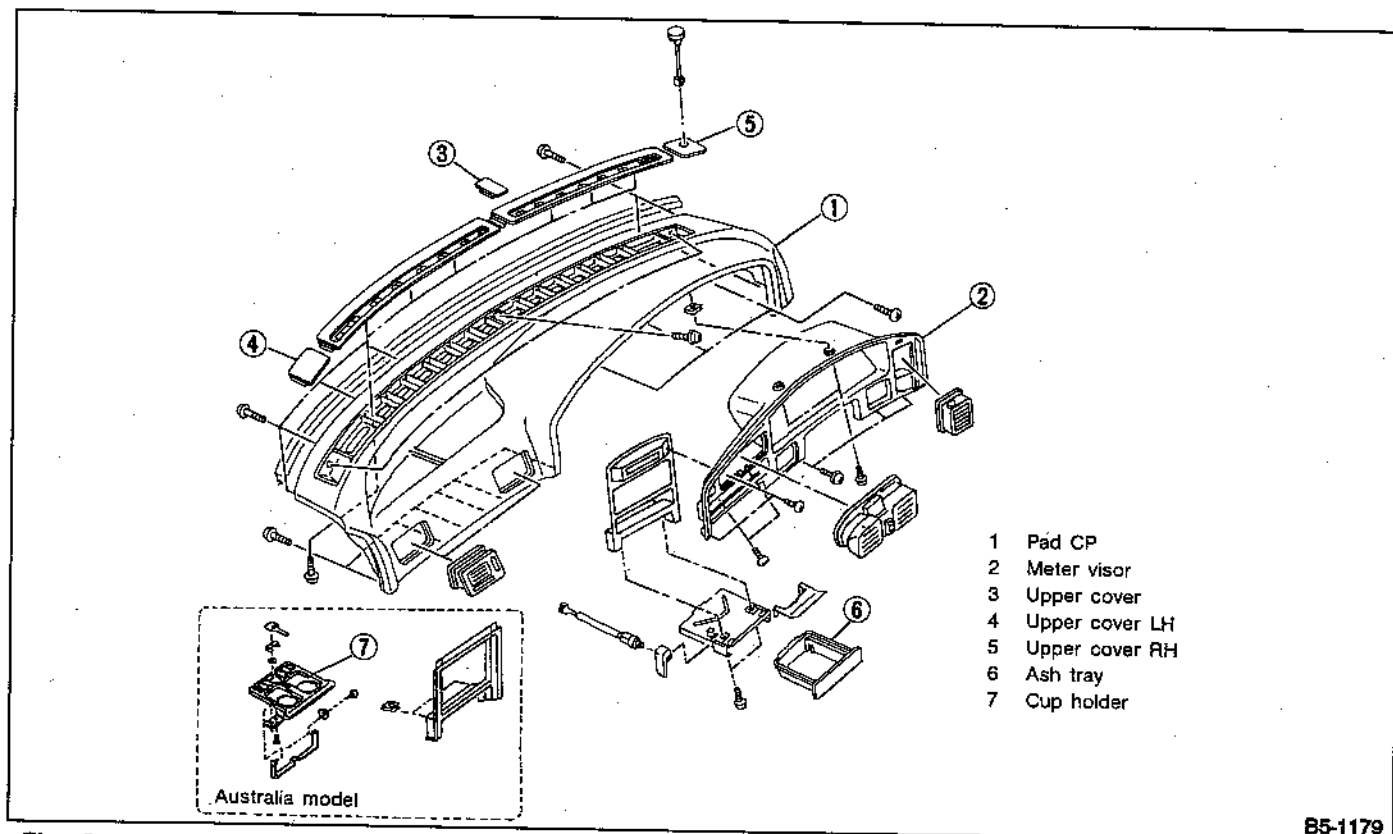


Fig. 9

B5-1179

A: REMOVAL

- 1) Pull out cup holder (only models for Australia) and ash tray from instrument panel.
- 2) Remove center panel by removing the four screws.

- 4) Remove the two screws on the upper side of heater control panel.
- 5) Remove the two screws on the upper side of meter.
- 6) Remove meter visor from instrument panel by pulling it up and forward.

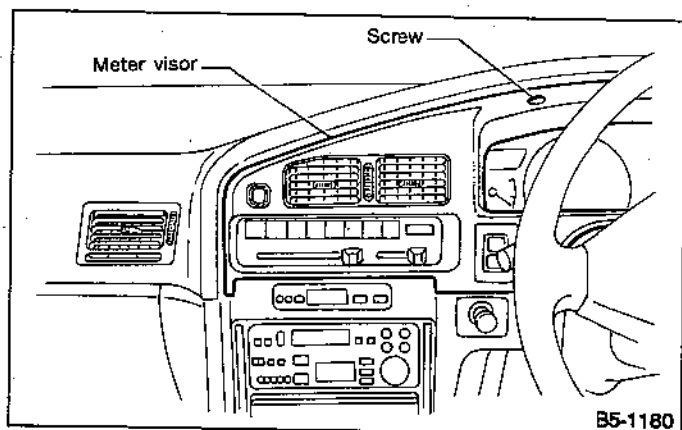


Fig. 10

B5-1180

- 3) Remove parts such as ventilation grills (both driver and center sides), switch box, mirror control switch, height control switch, and then remove the screw at the bottom of each part.

B: INSTALLATION

Installation is in the reverse order of removal.
After installation, make sure there is no clearance between parts.



SUBARU[®] LEGACY

1992 SERVICE MANUAL SECTION 2



SUBARU®

1992

SERVICE MANUAL

FOREWORD

This service manual has been prepared to provide SUBARU service personnel with the necessary information and data for the correct maintenance and repair of SUBARU vehicle.

This manual include the procedures for maintenance disassembling, reassembling, inspection and adjustment of components and troubleshooting for guidance of both the fully qualified and the less-experienced mechanics. Please peruse and utilize this manual fully to ensure complete repair work for satisfying our customers by keeping their vehicle in optimum condition. When replacement of parts during repair work is needed, be sure to use SUBARU genuine parts.

All information, illustration and specifications contained in this manual are based on the latest product information available at the time of publication approval.

FUJI HEAVY INDUSTRIES LTD.

All right reserved. This book may not be reproduced or copied, in whole or in part, without the written permission of
FUJI HEAVY INDUSTRIES LTD., TOKYO JAPAN.

SUBARU,  and  are trademarks of
FUJI HEAVY INDUSTRIES LTD.

© Copyright 1991 FUJI HEAVY INDUSTRIES LTD.

2 ENGINE SECTION

EMISSION CONTROL SYSTEM AND VACUUM FITTING	2-1
ON-CAR SERVICES	2-2
ENGINE (SOHC)	2-3a
ENGINE (DOHC)	2-3b
ENGINE LUBRICATION SYSTEM	2-4
ENGINE COOLING SYSTEM	2-5
CARBURETOR	2-6
FUEL INJECTION SYSTEM (MPFI Non-TURBO)	2-7a
FUEL INJECTION SYSTEM (SPFI)	2-7b
FUEL INJECTION SYSTEM (MPFI TURBO)	2-7c
FUEL SYSTEM	2-8
EXHAUST SYSTEM	2-9
CLUTCH	2-10
ENGINE AND TRANSMISSION MOUNTING SYSTEM	2-11

IMPORTANT SAFETY NOTICE

Providing appropriate service and repair is a matter of great importance in the serviceman's safety maintenance and safe operation, function and performance which the SUBARU vehicle possesses.

In case the replacement of parts or replenishment of consumables is required, genuine SUBARU parts whose parts numbers are designated or their equivalents must be utilized.

It must be made well known that the safety of the serviceman and the safe operation of the vehicle would be jeopardized if he used any service parts, consumables, special tools and work procedure manuals which are not approved or designated by SUBARU.

How to use this manual

- This Service Manual is divided into six volumes by section so that it can be used with ease at work. Refer to the Table of Contents, select and use the necessary section.
- Each chapter in the manual is basically made of the following five types of areas.

M : Mechanism and function
S : Specifications and service data
C : Component parts
W : Service procedure
(X : Service procedure)
(Y : Service procedure)
T : Troubleshooting

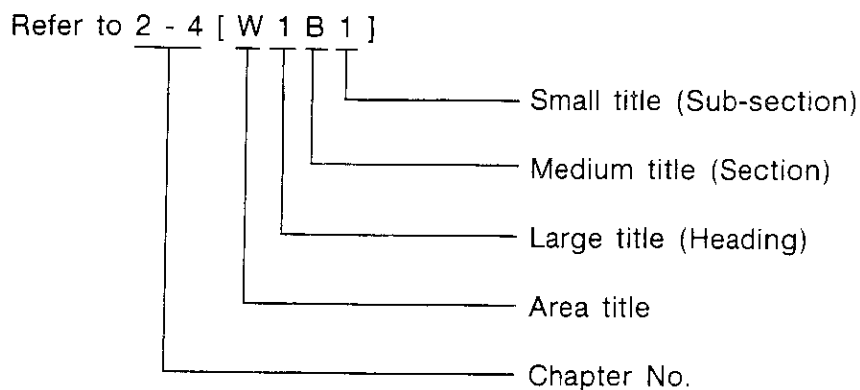
- The description of each area is provided with four types of titles different in size as shown below. The Title No. or Symbol prefixes each title in order that the construction of the article and the flow of explanation can be easily understood.

[Example of each title]

- Area title: W. Service procedure (one of the five types of areas)
- Large title (Heading): 1. Oil Pump (to denote the main item of explanation)
- Medium title (Section): A. REMOVAL (to denote the type of work in principle)
- Small title (Sub-section): 1. INNER ROTATOR (to denote a derivative item of explanation)

- The Title Index No. is indicated on the top left (or right) side of the page as the book is opened. This is useful for retrieving the necessary portion.

(Example of usage)



Example of title placement

CLUTCH

2-10 [W 1 A 0]

W SERVICE PROCEDURE

1.General

A: PRECAUTION

When servicing clutch system, pay attention to the following items.

- 1) Check the routing of clutch cable for smoothness.
- 2) Excessive tightness or looseness of clutch cable have a bad influence upon the cable durability.
- 3) Apply grease sufficiently to the connecting portion of clutch pedal.
- 4) Apply grease sufficiently to the release lever portion.
- 5) Position clutch cable through the center of toeboard hole.

Adjustment is done by

2.RELEASE LEVER

Check lever pivot portion and the point of contact with holder for wear.


2.Release Bearing and Lever

A: REMOVAL

2) Seal

Area title
 Large title
 Medium title
 Small title

- In this manual, the following symbols are used.

 : Should be lubricated with oil.

 : Should be lubricated with grease.

 : Sealing point

 : Tightening torque

TABLE OF CONTENTS

1	GENERAL SECTION	<ul style="list-style-type: none"> 1-1 Specifications 1-2 ★★★★★★★★★★ 1-3 General Information 1-4 Pre-Delivery Inspection 1-5 Periodic Maintenance Services 1-6 Special Tools
2	ENGINE SECTION	<ul style="list-style-type: none"> 2-1 Emission Control System and Vacuum Fitting 2-2 On-Car Services 2-3a Engine (SOHC) 2-3b Engine (DOHC) 2-4 Engine Lubrication System 2-5 Engine Cooling System 2-6 Carburetor 2-7a Fuel Injection System (MPFI Non-TURBO) 2-7b Fuel Injection System (SPFI) 2-7c Fuel Injection System (MPFI TURBO) 2-8 Fuel System 2-9 Exhaust System 2-10 Clutch 2-11 Engine and Transmission Mounting System
3	TRANSMISSION AND DIFFERENTIAL SECTION	<ul style="list-style-type: none"> 3-1 Manual Transmission and Differential 3-2a Automatic Transmission and Differential (4AT) 3-2b ★★★★★★★★★★ 3-3 Transmission Control System 3-4 4WD System
4	MECHANICAL COMPONENTS SECTION	<ul style="list-style-type: none"> 4-1 Suspension 4-2 Wheels and Axles 4-3 Steering System 4-4 Brakes 4-5 Pedal System and Control Cables 4-6 Heater and Ventilator 4-7 ★★★★★★★★★★
5	BODY SECTION	<ul style="list-style-type: none"> 5-1 Body and Exterior 5-2 Doors and Windows 5-3 Seats, Seat Belts, and Interior 5-4 Instrument Panel
6	ELECTRICAL SECTION	<ul style="list-style-type: none"> 6-1 Engine Electrical System 6-2 Body Electrical System 6-3 Wiring Diagram and Trouble-shooting

SUBARU®

1992

**SERVICE
MANUAL**

	Page
1. System Application	2
2. Schematic Drawing	3
3. General Precautions	11
4. Crankcase Emission Control System	11
5. Three-way Catalyst	13
6. A/F Control System	13
7. Ignition Control System	14
8. Evaporative Emission Control System	17
9. Vacuum Fitting	22



1. System Application

There are three emission control systems which are as follows:

- 1) Crankcase emission control system
- 2) Exhaust emission control system

- Three-way catalyst system
 - A/F control system
 - Ignition control system
- 3) Evaporative emission control system

*: On Australia model, not equipped rear catalyst

Item	Main components	Function	2200cc MPFI		2000cc MPFI		1800cc		1600cc	
			Catalyst model	Non catalyst model	Turbo	Non-Turbo	SPFI	Carburetor	Carburetor	
Crankcase emission control system	PCV valve	Draws blow-by gas into intake manifold from crankcase and burns it together with air-fuel mixture. Amount of blow-by gas to be drawn in is controlled by intake manifold vacuum pressure.	○	○	○	○	○	○	○	
Exhaust emission control system	Catalyst system	Three-way catalyst	○*	—	○*	○	○	—	—	
	A/F control system	ECU (Electronic Control Unit)	Receives input signals from various sensors, compares these signals with stored data, and emits a signal for optimal control of air-fuel mixture ratio.	○	○	○	○	○	—	—
		O ₂ sensor	Detects density of oxygen contained in exhaust gases.	○	—	○	○	○	—	—
		Air flow sensor	Detects amount of intake air.	○	○	○	○	○	—	—
		Throttle sensor	Detects throttle valve position and idle position signal.	○	○	○	○	○	—	—
	Ignition control system	ECU	Receives various signals, compares these signals with basic data stored in memory, and emits a signal for optimal control of ignition timing.	○	○	○	○	○	—	—
		Crank angle sensor	Detects engine's revolution speed.	○	○	○	○	○	—	—
		Cam angle sensor	Detects reference signal for combustion cylinder discrimination.	○	○	○	○	○	—	—
		Water temperature sensor	Emits a coolant temperature signal.	○	○	○	○	○	—	—
		Knock sensor	Detects a knock signal and sends to ECU.	○	○	○	—	○	—	—
		Centrifugal advancer	Controls ignition timing in response to engine speed.	—	—	—	—	—	○	○
	Vacuum advancer	Controls ignition timing by intake manifold vacuum pressure, according to engine load.	—	—	—	—	—	○	○	
Evaporative emission control system	Canister	Adsorbs evaporative gas which occurs in fuel tank when engine stops, and sends it to combustion chambers for a complete burn when engine is started. This prevents HC from being discharged into atmosphere.	○	○	○	○	○	○	○	
	Purge control solenoid valve	Receives a signal from ECU and controls purge of evaporative gas adsorbed by canister.	○	○	○	○	○	—	—	
	Thermo valve	Controls purging of evaporative gases adsorbed on canister by controlling coolant temperature.	—	—	—	—	—	○	○	
	Switch vent solenoid valve	Introduces evaporative gas from carburetor float chamber into canister when ignition switch is ON.	—	—	—	—	—	○	○	
	Auxiliary purge control valve	Controls purge of evaporative gas sent to resonator chamber from canister.	—	—	○	—	—	—	—	

2. Schematic Drawing

1. 2200cc MPFI CATALYST MODEL [Except Australia model]

[Non-TURBO]

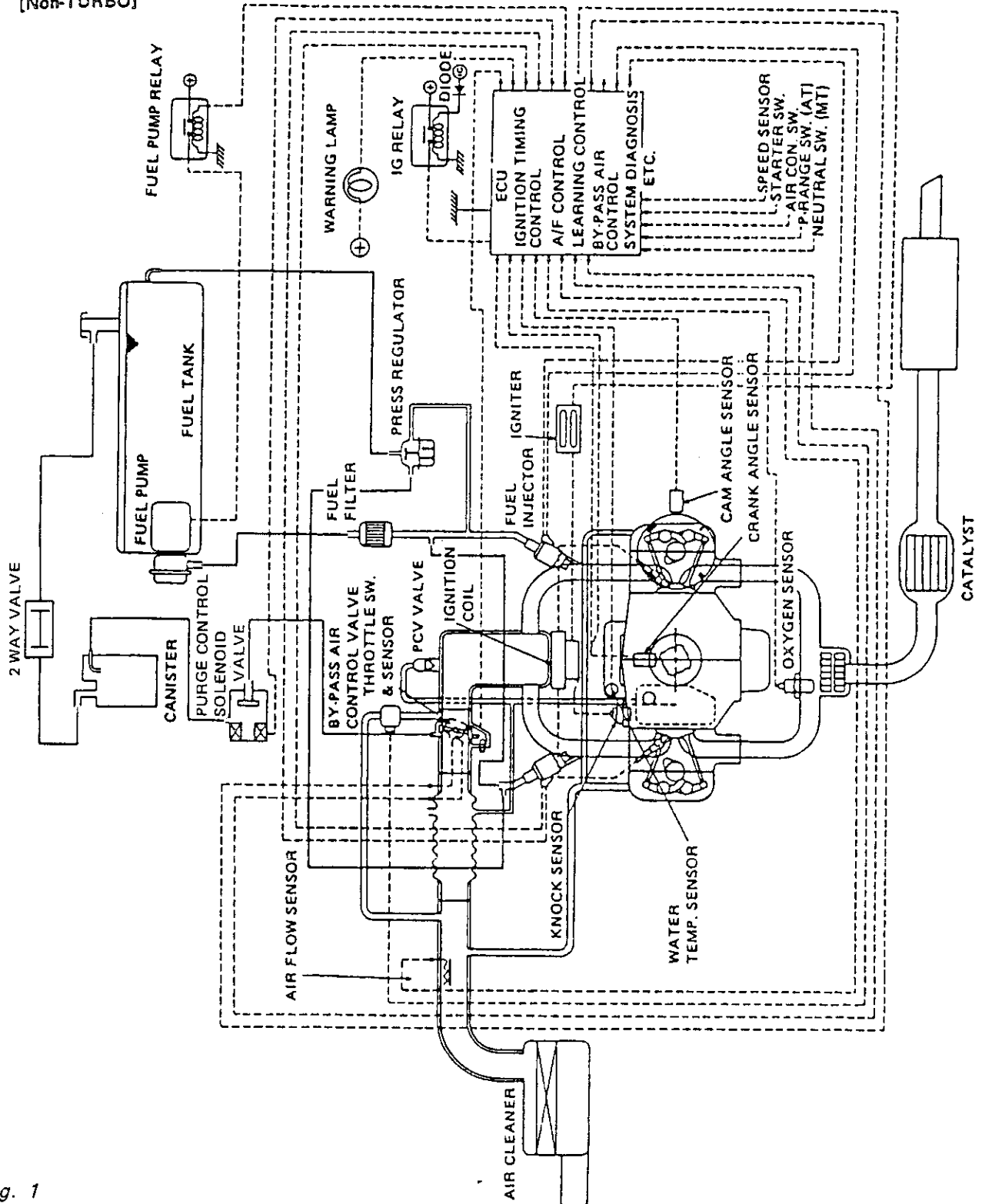


Fig. 1

[Australia model]

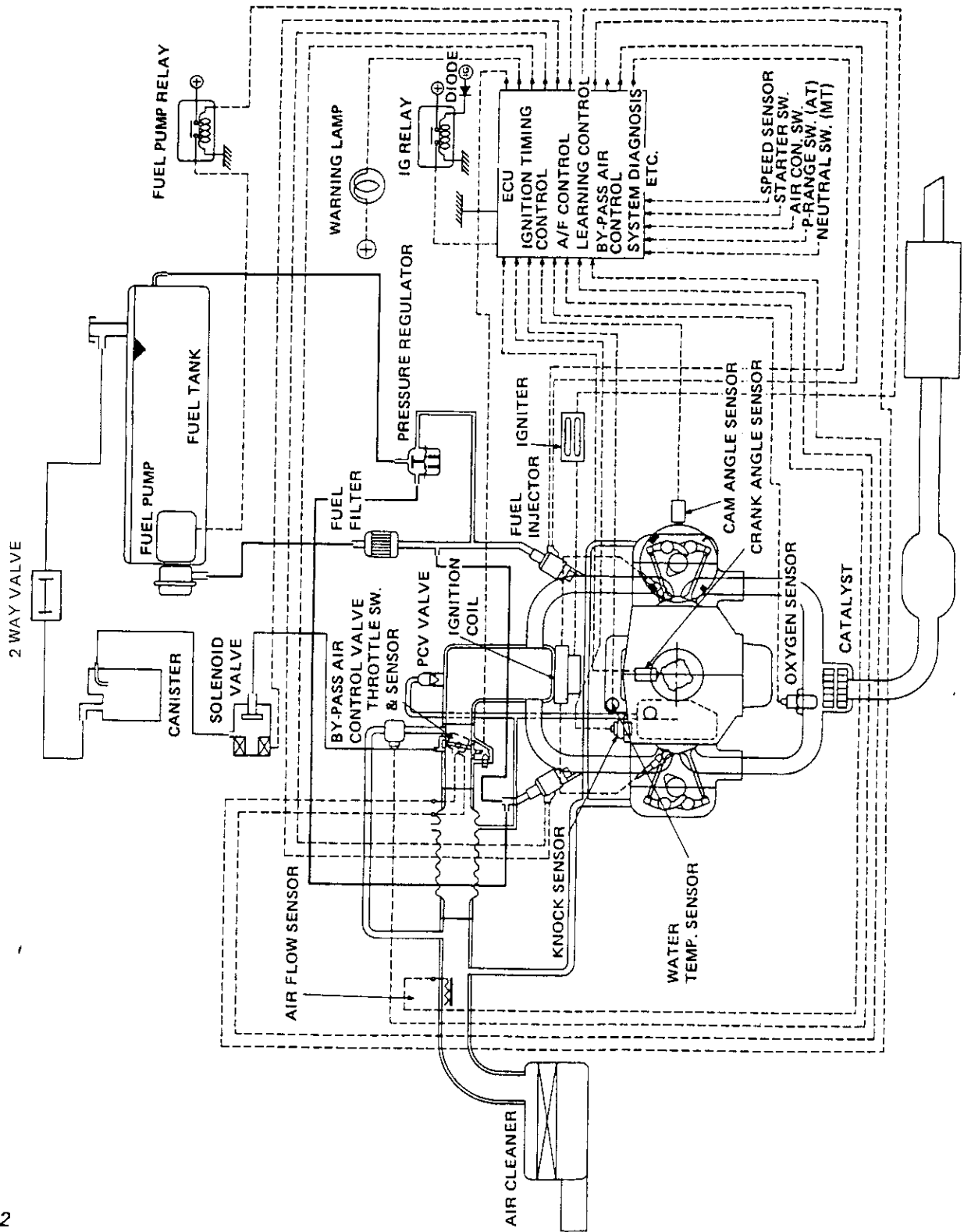


Fig. 2

B2-530

2. 2200cc MPFI NON-CATALYST MODEL

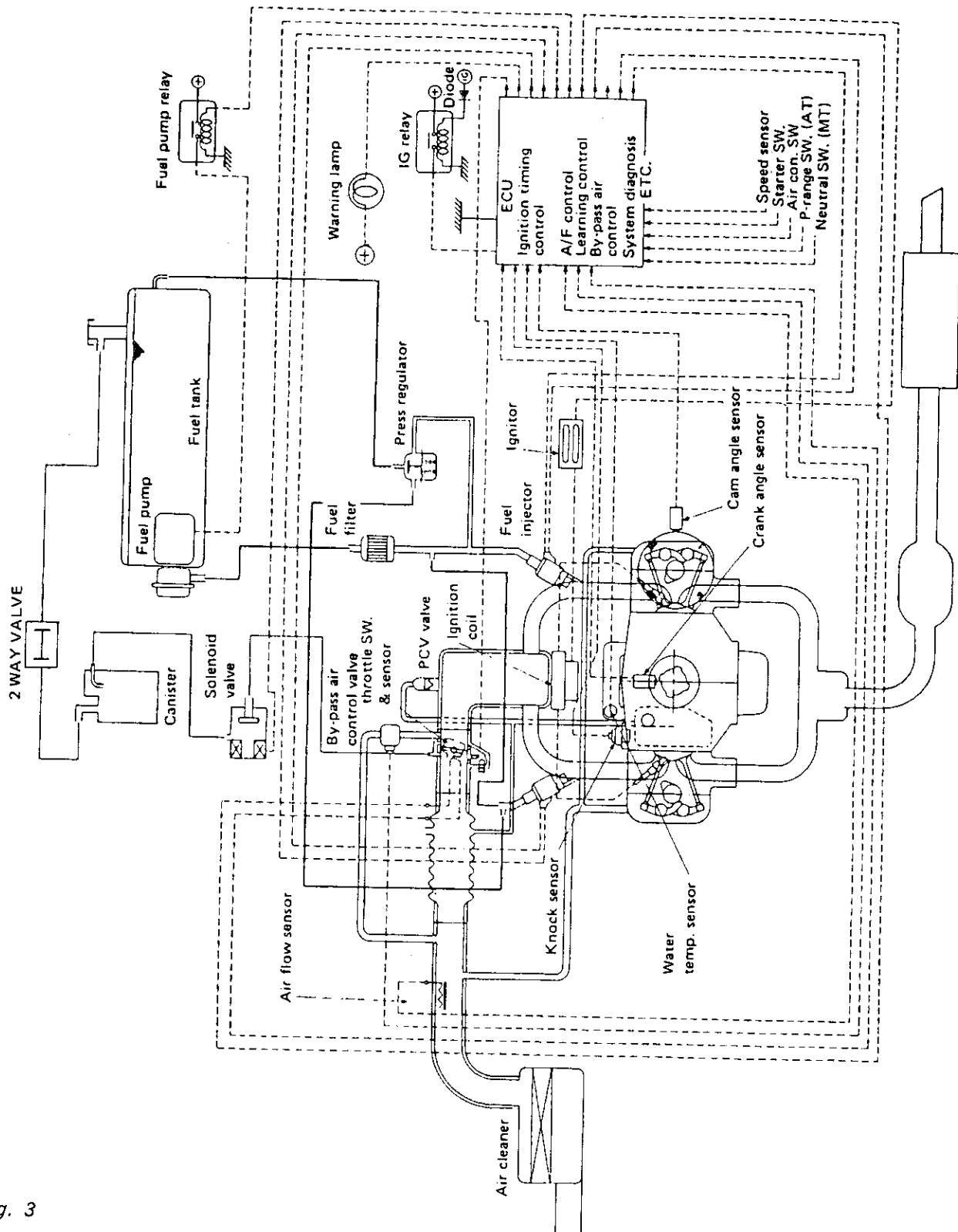


Fig. 3

B2-374

3. 2000cc MPFI NON-TURBO MODEL

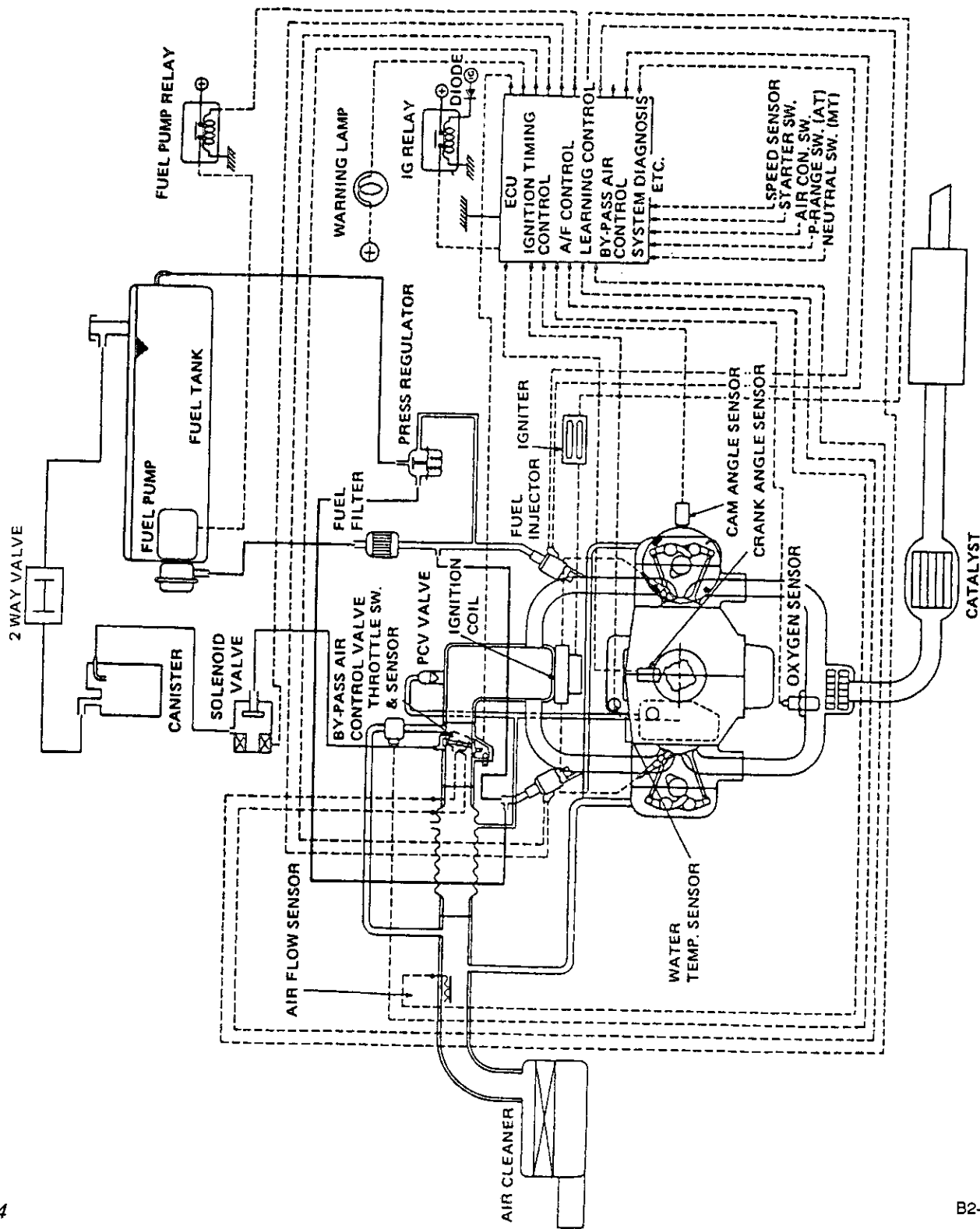


Fig. 4

4. 2000cc MPFI TURBO MODEL [Except Australia model]

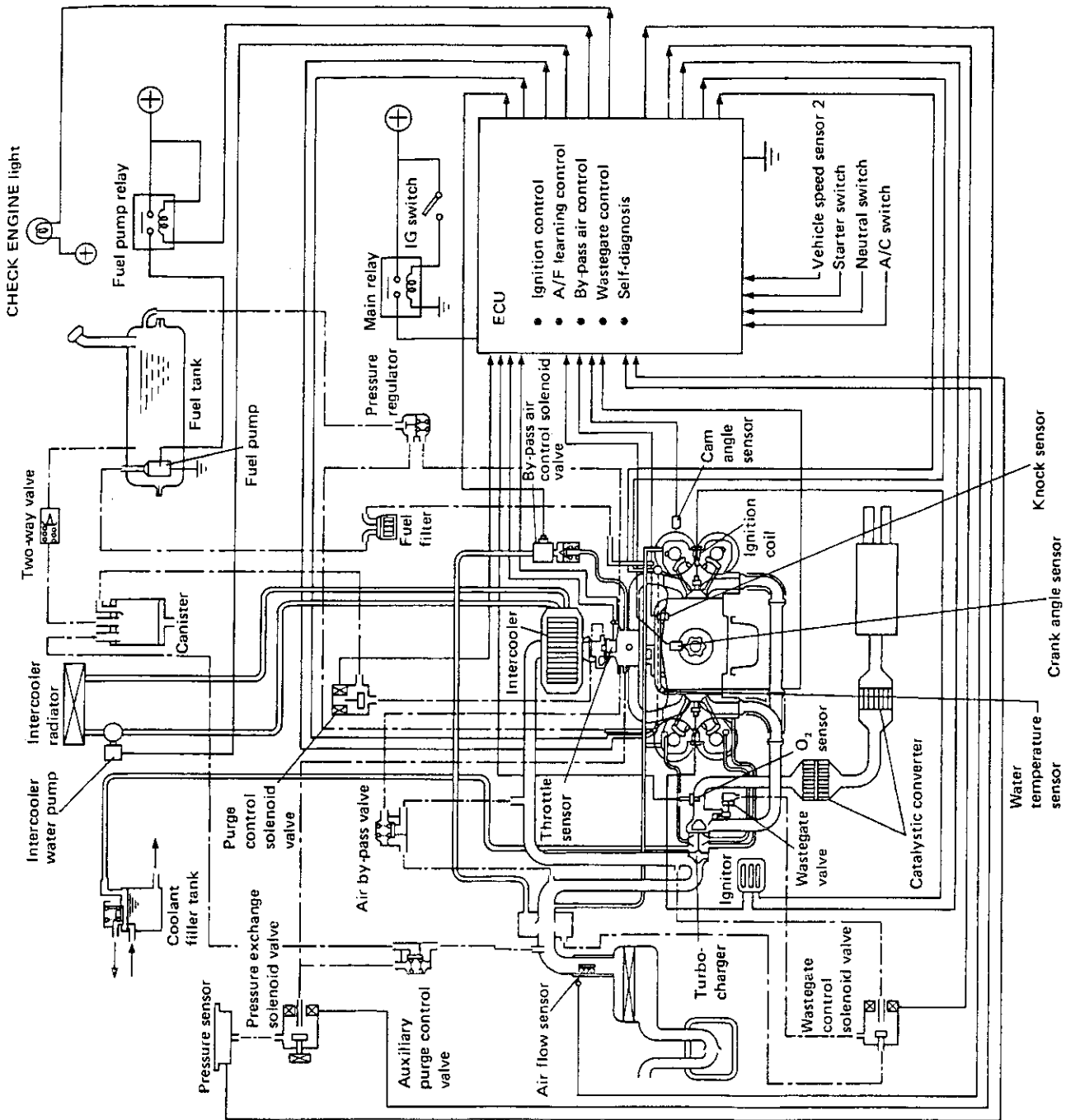


Fig. 5

B2-1037

[Australia model]

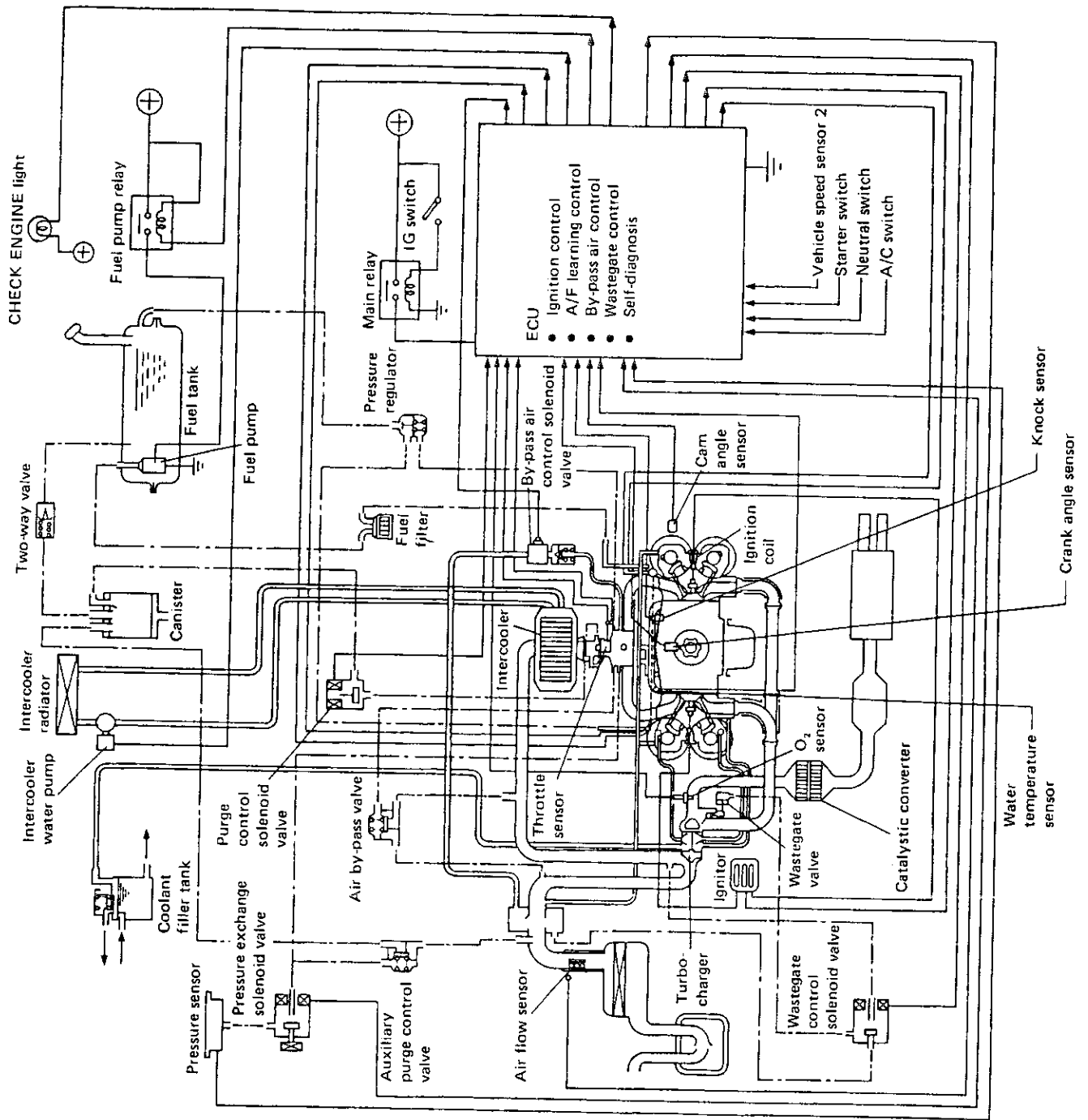


Fig. 6

B2-1115

5. 1800cc SPFI MODEL

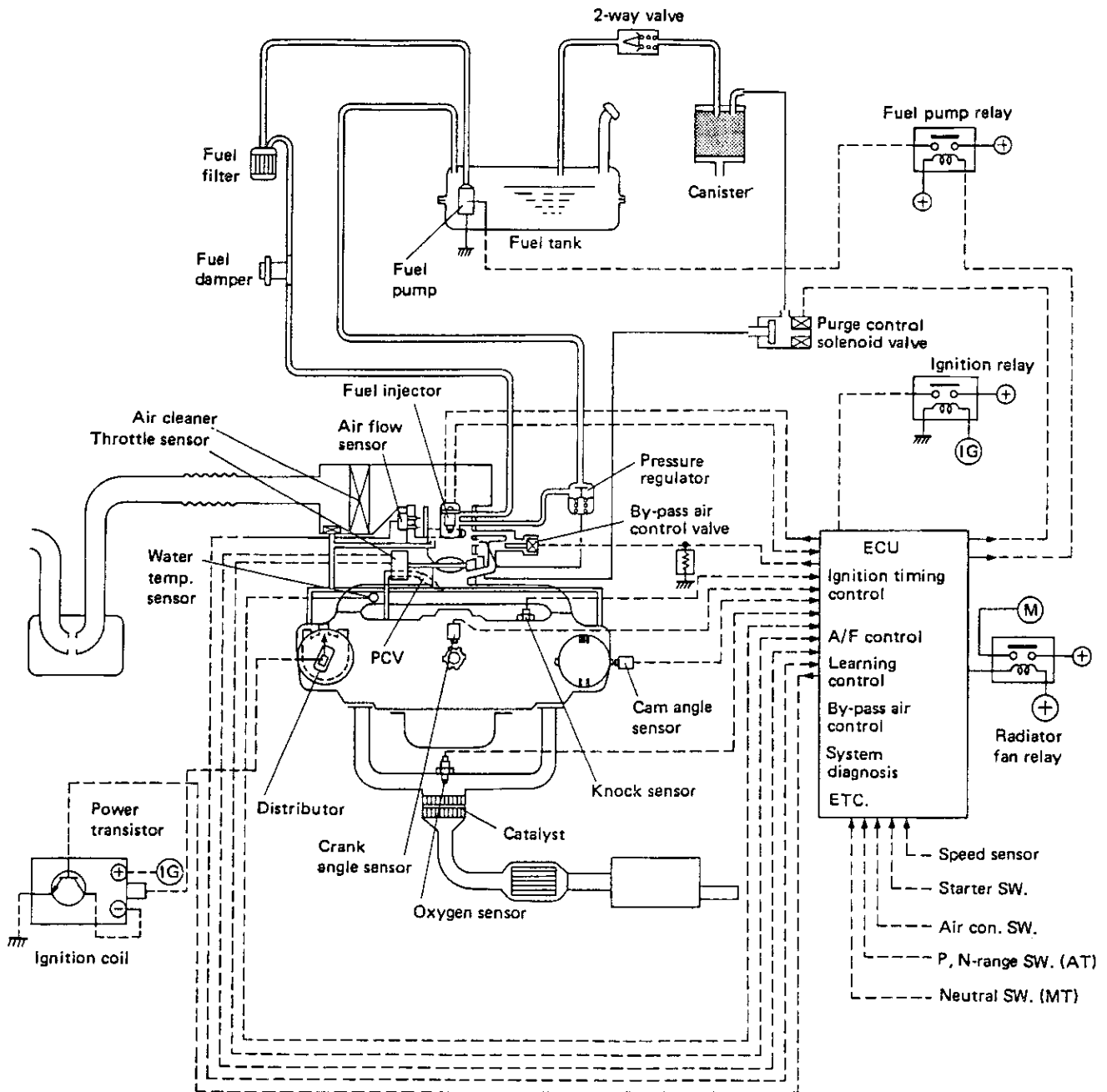


Fig. 7

B2-375

6. 1800cc and 1600cc CARBURETOR MODELS

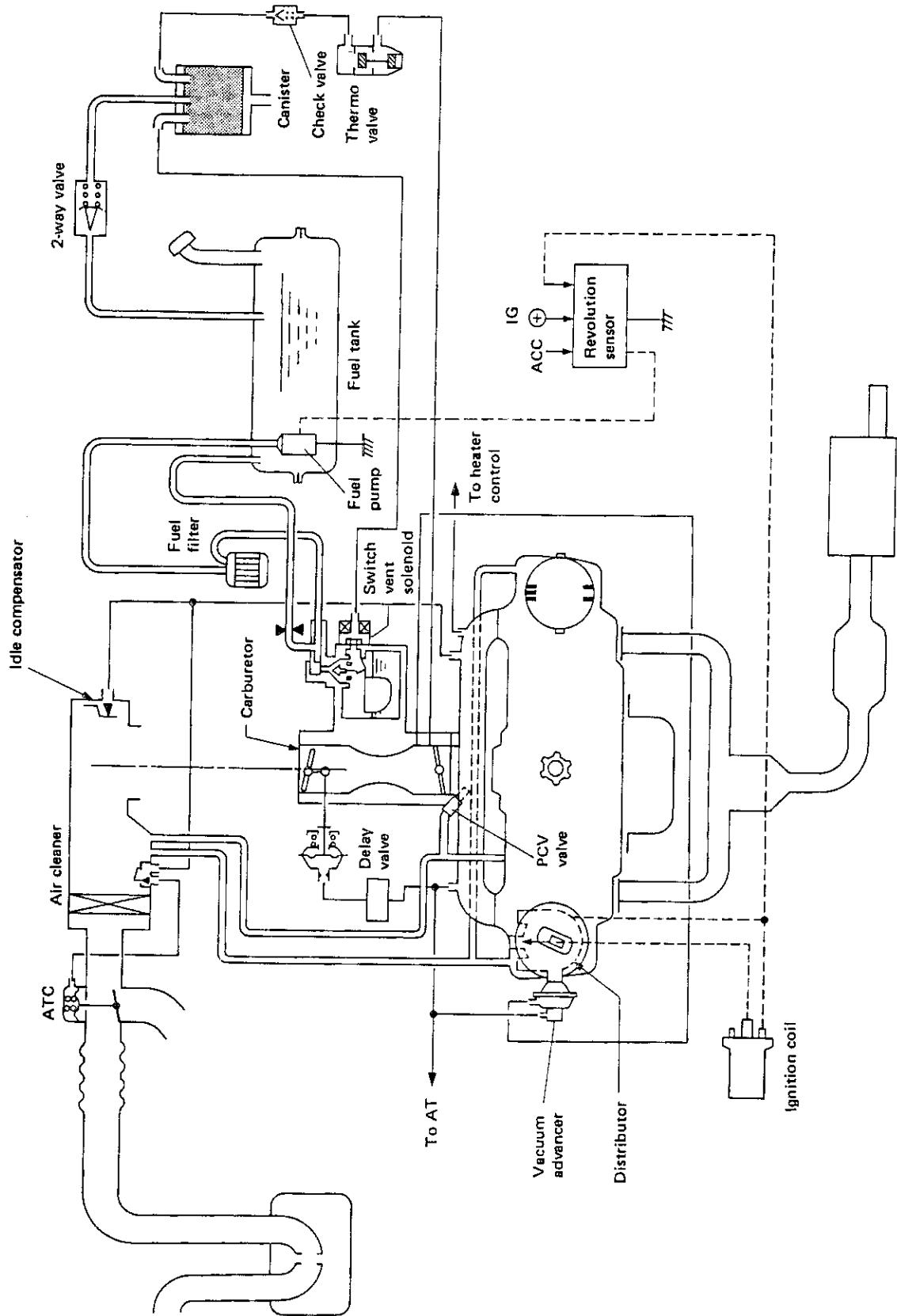


Fig. 8

B2-376

3. General Precautions

1) Know the importance of periodic maintenance services.

(1) Every service item in the periodic maintenance schedule must be performed.

(2) Failing to do even one item can cause the engine to run poorly and increase exhaust emissions.

2) Determine if you have an engine or emission system problem.

(1) Engine problems are usually not caused by the emission control systems.

(2) When troubleshooting, always check the engine and ignition system or fuel injection system first.

3) Check hose and wiring connections first.

The most frequent cause of problems is simply a bad connection in the wiring or vacuum hoses. Always make sure that connections are secure and correct.

4) Avoid coasting with the ignition turned off and prolonged engine braking.

5) Do not damage parts.

(1) To disconnect vacuum hoses, pull on the end, not the middle of the hose.

(2) To pull apart electrical connectors, pull on the connector itself, not the wire.

(3) Be careful not to drop electrical parts, such as sensors, or relays.

If they are dropped on a hard floor, they should be replaced and not reused.

(4) When checking continuity at the wire connector, the test bar should be inserted carefully to prevent terminals from bending.

6) Use SUBARU genuine parts.

7) Record how hoses are connected before disconnecting.

(1) When disconnecting vacuum hoses, use tags to identify how they should be reconnected.

(2) After completing a job, double check to see that the vacuum hoses are properly connected. See the "Vacuum connections label" under the hood.

4. Crankcase Emission Control System

A: DESCRIPTION

The positive crankcase ventilation (PCV) system is employed to prevent air pollution which will be caused by blow-by gas being emitted from the crankcase.

The system consists of a sealed oil filler cap, connecting hoses, PCV valve, and rocker covers with a port which works as an emission outlet or a fresh air inlet in response to the following condition.

At part throttle, the blow-by gas in the crankcase flows into the intake manifold through the connecting hose, and PCV valve by the strong vacuum of the intake manifold. Under this condition, fresh air is introduced into the rocker covers through the connecting hoses of both cylinder sides, and is drawn into the intake manifold through the PCV valve together with blow-by gas.

At wide open throttle, a part of blow-by gas flows into the *1air intake duct or *2air cleaner case through the connecting hoses and is drawn to the throttle chamber or carburetor because under this condition, the intake manifold vacuum is not so strong as to introduce all blow-by gases increasing with engine speed directly through the PCV valve.

*1: 2200cc and 2000cc models

*2: 1800cc and 1600cc models

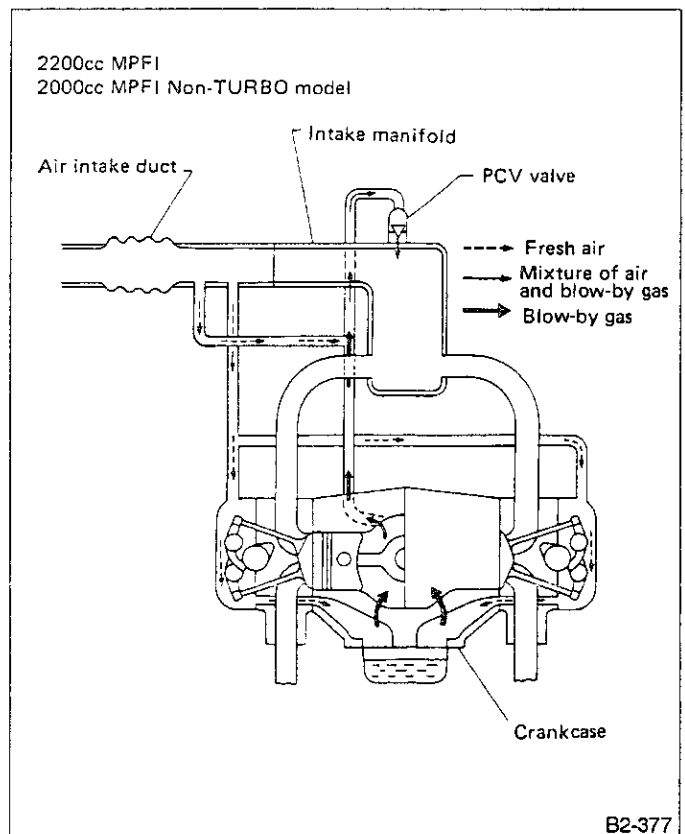


Fig. 9

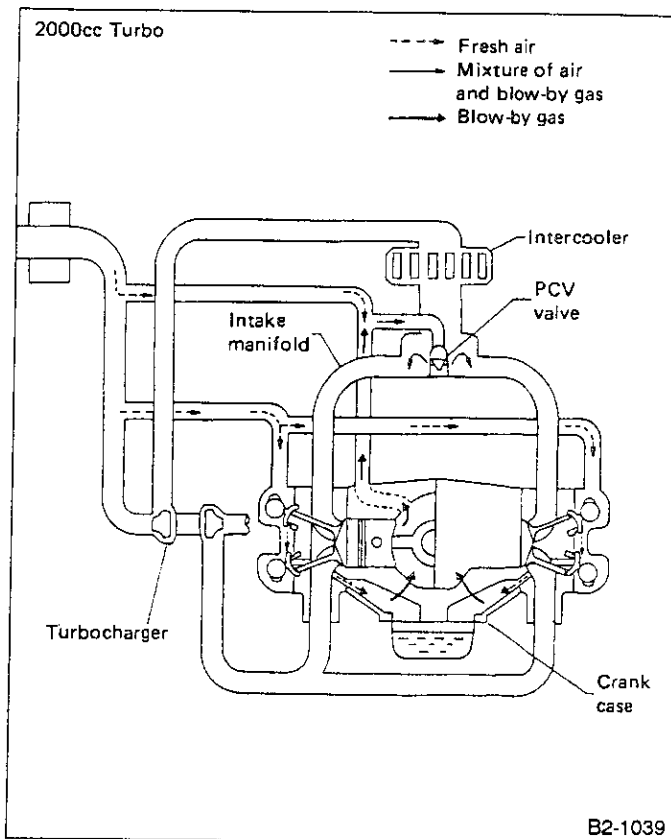


Fig. 10

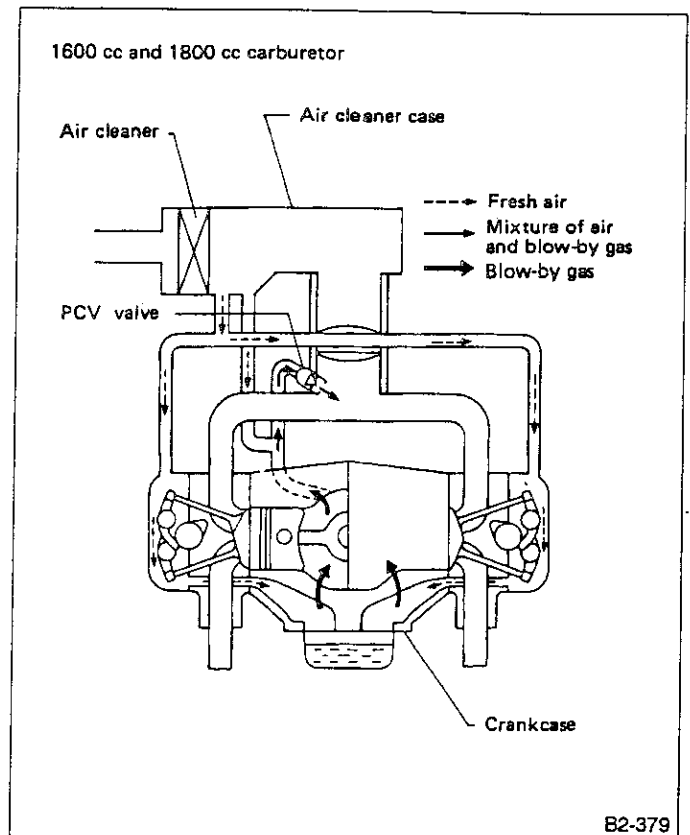


Fig. 12

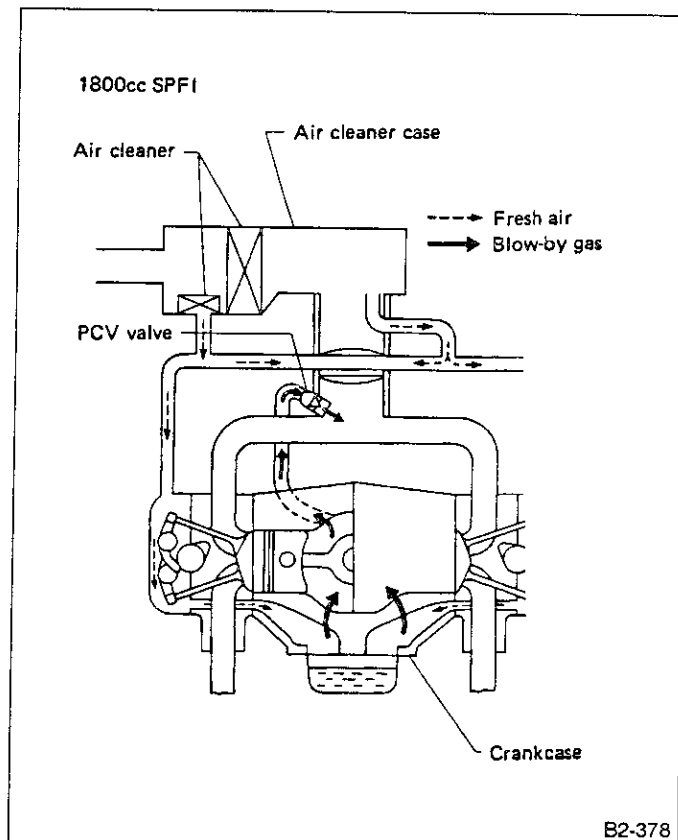


Fig. 11

B: INSPECTION

- 1) Check the positive crankcase ventilation hoses and connections for leaks and clogging. The hoses may be cleared with compressed air.
- 2) Check the oil filler cap to insure that the gasket is not damaged and the cap fits firmly on the filler cap end.
- 3) Check the PCV valve as the following procedure.
 - (1) Disconnect the hose from the PCV valve.
 - (2) With a finger attaching top of the valve, then lightly open and close the throttle valve (increase and decrease the engine speed a little).
 - (3) The valve is in good condition if a vacuum is felt by the finger. If not, replace the valve.
 - (4) The valve alone may be checked by shaking it. It is normal when you hear it move. Replace it if it fails to move.

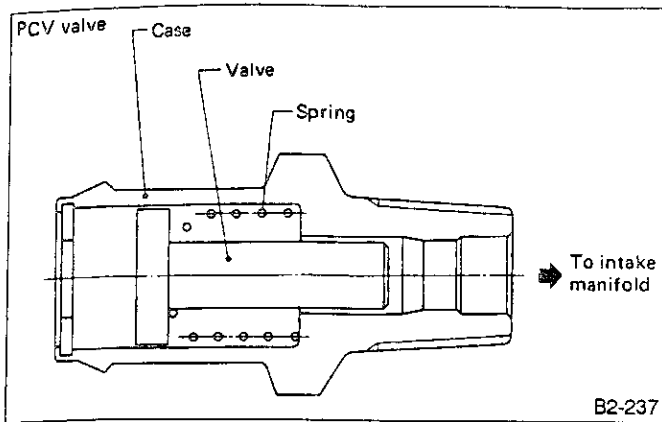


Fig. 13

5. Three-way Catalyst

The basic material of three-way catalyst is platinum (Pt) and rhodium (Rh), and a thin film of their mixture is applied onto honeycomb or porous ceramics of an oval shape (carrier). To avoid damaging the catalyst, only unleaded gasoline should be used.

The catalyst is used to reduce HC, CO and NO_x in exhaust gases, and permits simultaneous oxidation and reduction. To obtain an excellent purification efficiency on all components HC, CO and NO_x, a balance should be kept among the concentrations of the components. These concentrations vary with the air-fuel ratio.

The air-fuel ratio needs to be controlled to a value within the very narrow range covering around the theoretical (stoichiometric) air-fuel ratio to purify the components efficiently.

6. A/F Control System

1. 2200cc MPFI CATALYST MODEL, 2000cc MPFI MODEL and 1800cc SPFI MODEL

The air/fuel control system compensates for the basic amount of fuel injection in response to a signal sent from the O₂ sensor to provide proper feedback control of the mixture. Thus, the theoretical air-fuel ratio is maintained to provide effective operation of the three-way catalyst. The basic amount of fuel injection is pre-set according to engine speed and loads, as well as the amount of intake air.

This system also has a "learning" control function which stores the corrected data in relation to the basic amount of fuel injection in the memory map. A new air-fuel ratio correction is automatically added for quick response to the deviation of the air-fuel ratio. Thus, the air-fuel ratio is optimally maintained under various conditions while stabilizing exhaust gases, improving driving performance and compensating for changes in sensors' performance quality with elapse of time.

Refer to 2-7 "FUEL INJECTION SYSTEM".

2. 2200cc MPFI NON-CATALYST MODEL

Based on input signals (car speed, coolant temperature, engine speed, intake air flow, throttle position, etc.) from various sensors, the ECU determines the engine operating conditions.

It then computes and controls the amount of fuel injected by the fuel injectors under varying conditions in order to maintain the optimum air-fuel ratio at all times.

7. Ignition Control System

1. MPFI AND SPFI MODELS

The ignition control system is controlled by the ECU. The ECU determines the optimal ignition timing according to signals sent from various sensors (which monitor the operating conditions of the engine), and sends a signal to the igniters.

The ECU has a "learning" control function which provides superb transient characteristics for responsive ignition timing control. (Except 2000cc MPFI Non-Turbo model).

Refer to 2-7 "FUEL INJECTION SYSTEM".

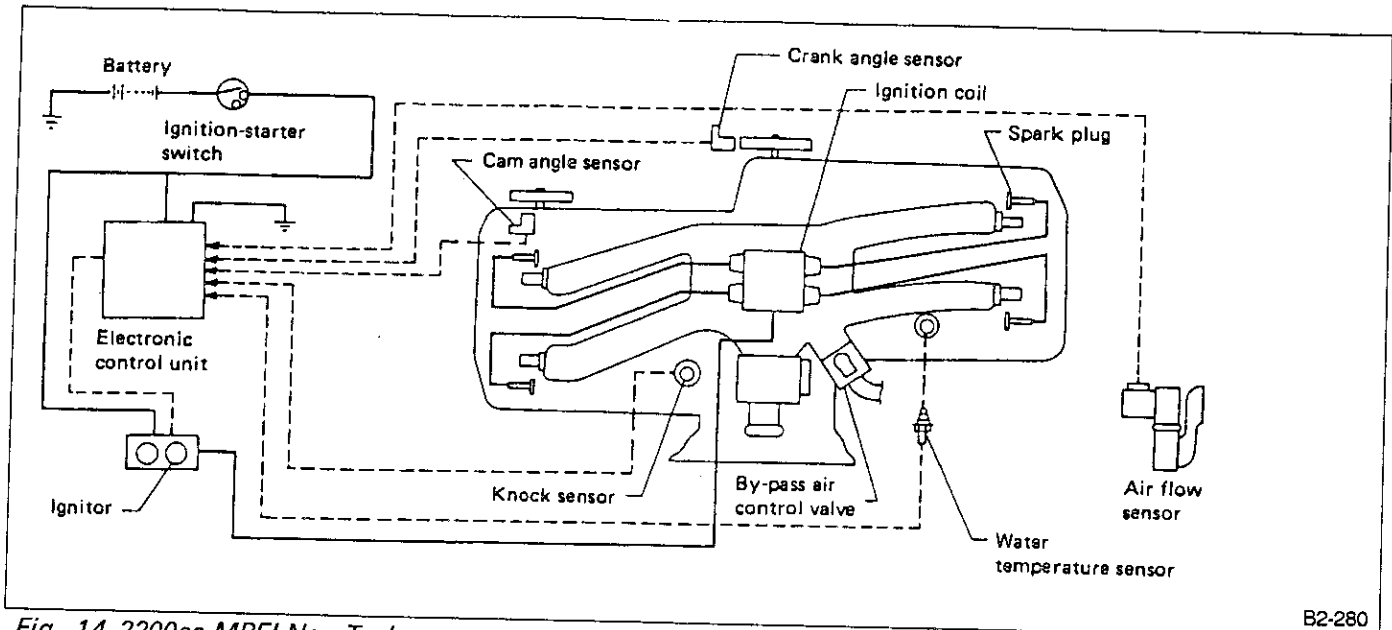


Fig. 14 2200cc MPFI Non-Turbo

B2-280

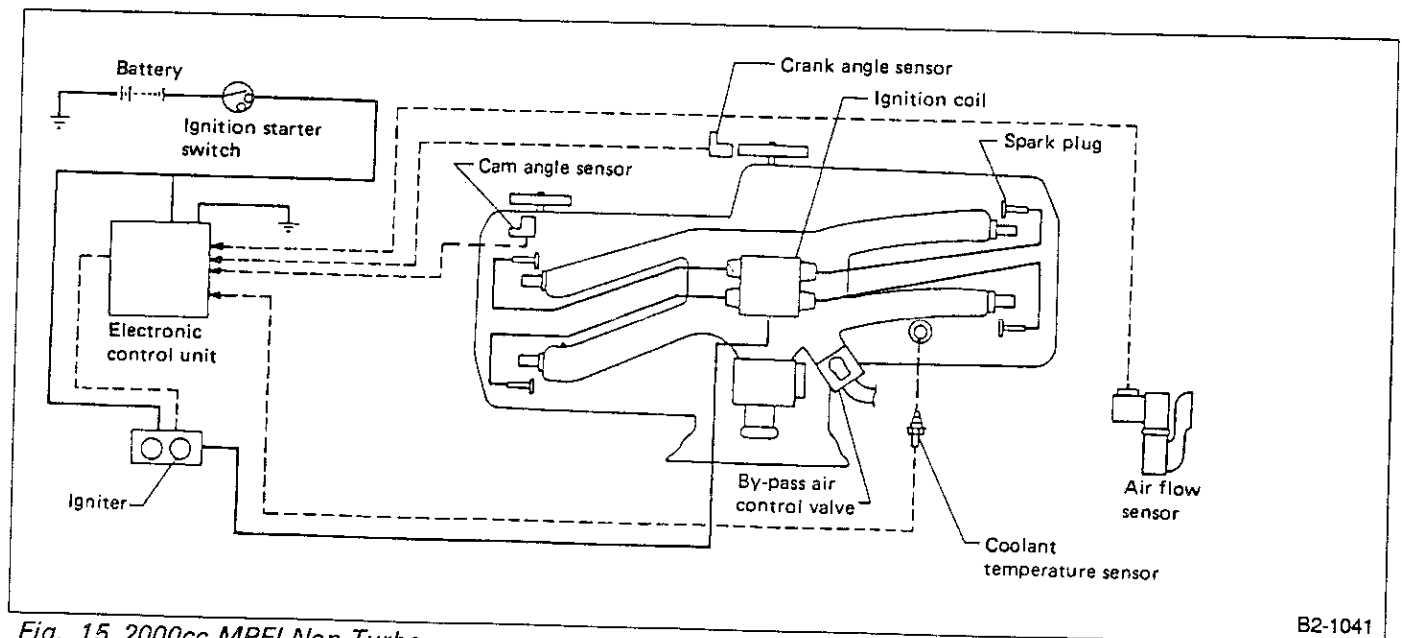


Fig. 15 2000cc MPFI Non-Turbo

B2-1041

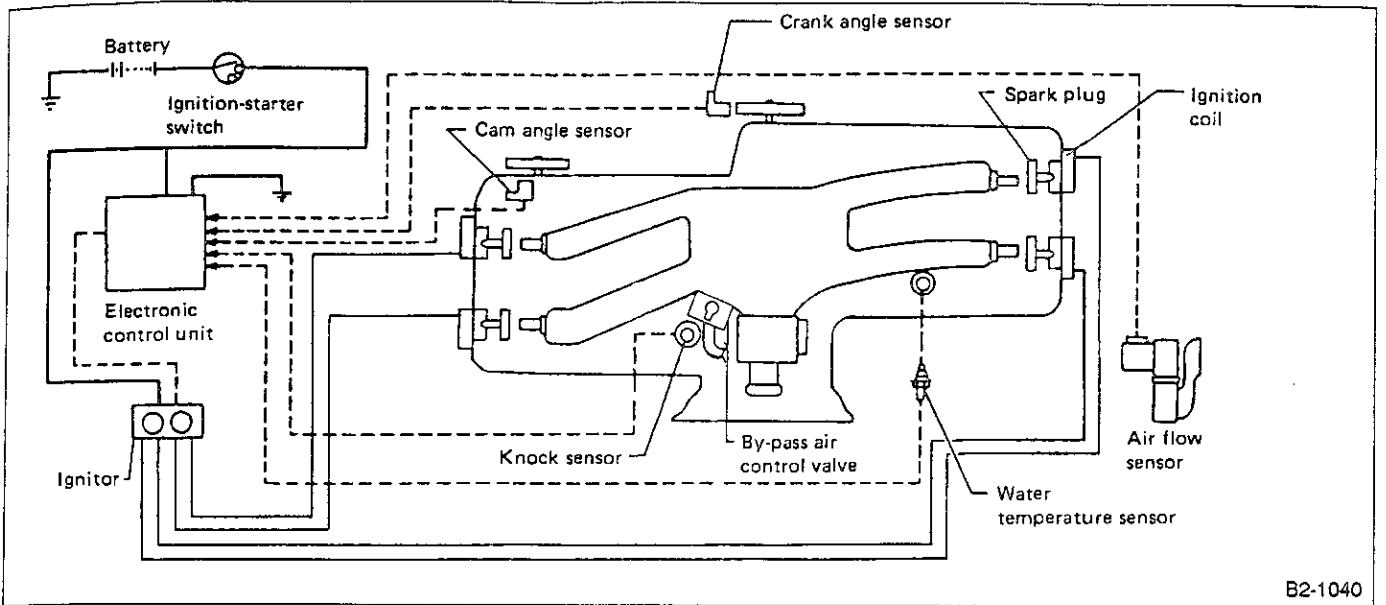


Fig. 16 2000cc MPFI Turbo

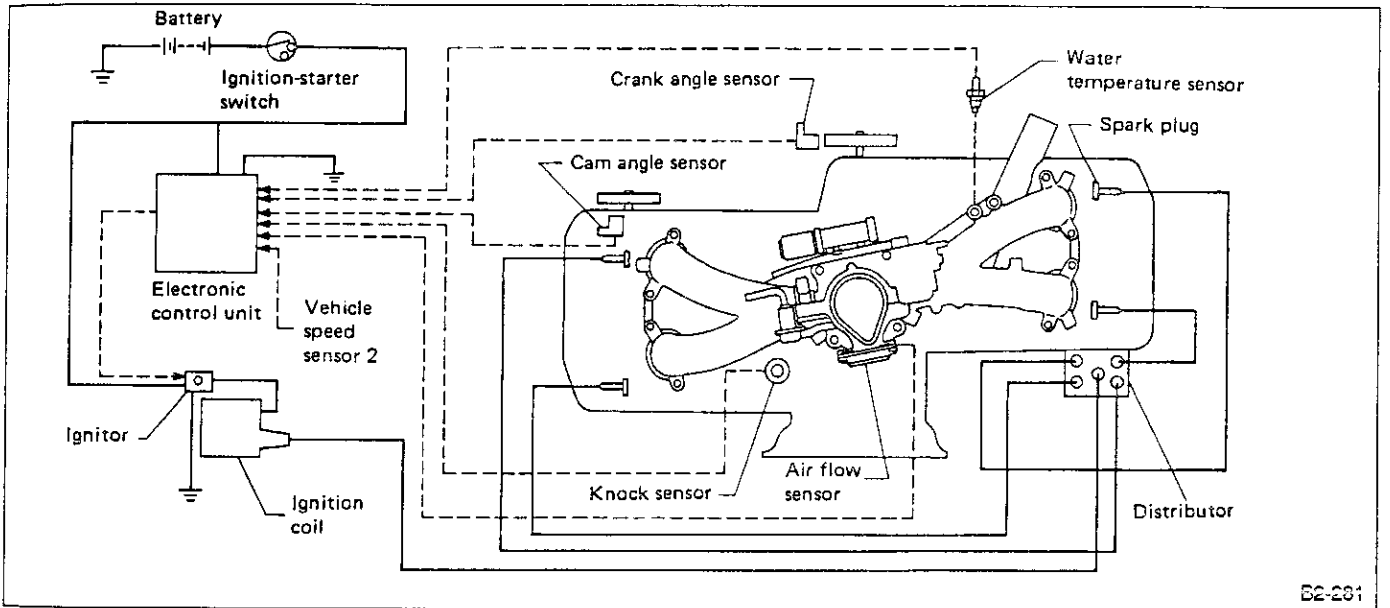


Fig. 17 1800cc SPFI

2. CARBURETOR MODELS

Ignition control system is aimed to reduce HC, CO and NOx emissions through the whole operating conditions. Actual ignition timing is controlled by the combination of a centrifugal advancer and a vacuum controller of distributor.

1800cc carburetor (MT, 3AT)

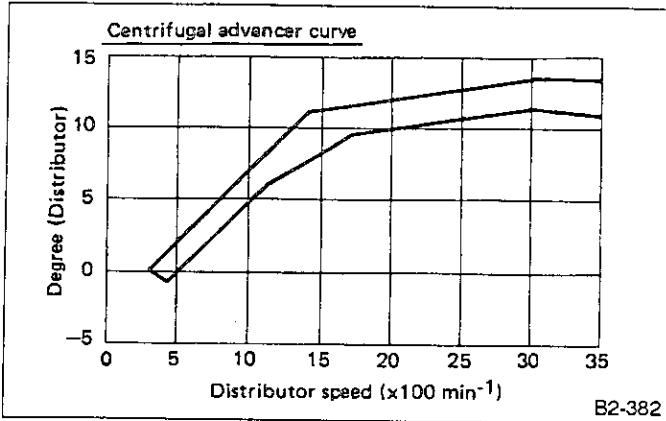


Fig. 18

B2-382

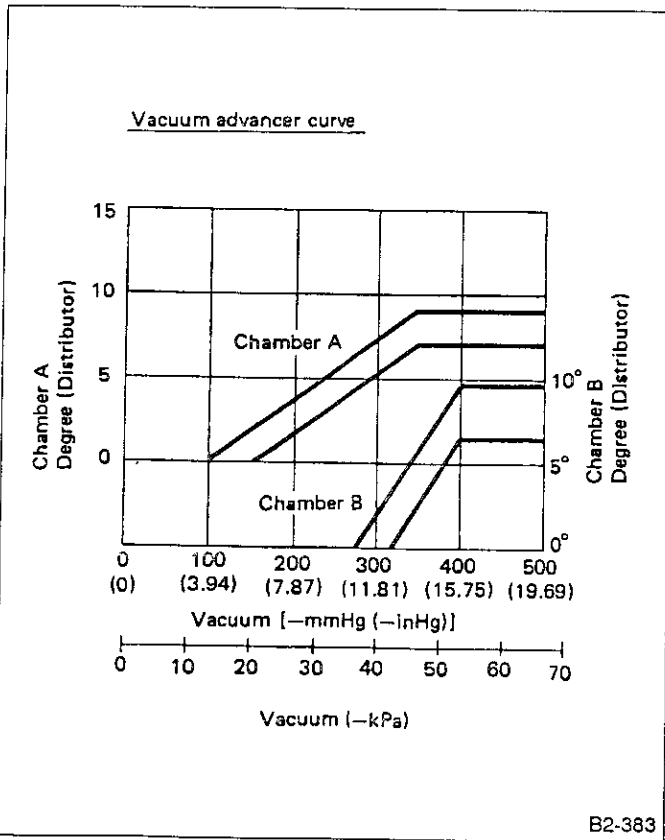


Fig. 19

B2-383

1800cc carburetor (4AT)

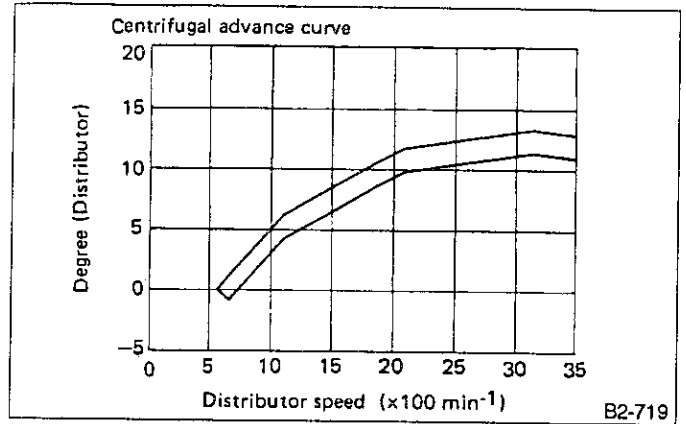


Fig. 20

B2-719

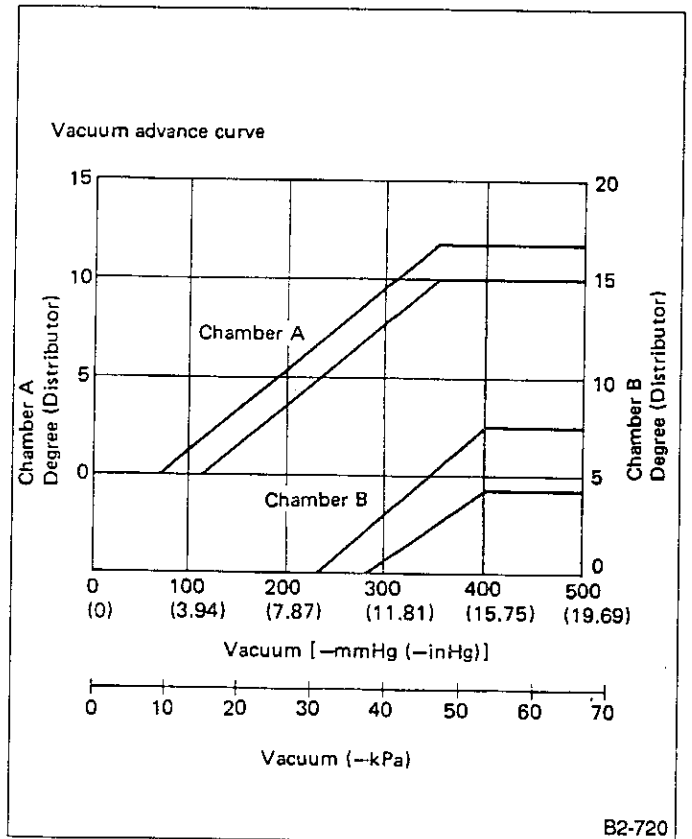


Fig. 21

B2-720

1600cc carburetor

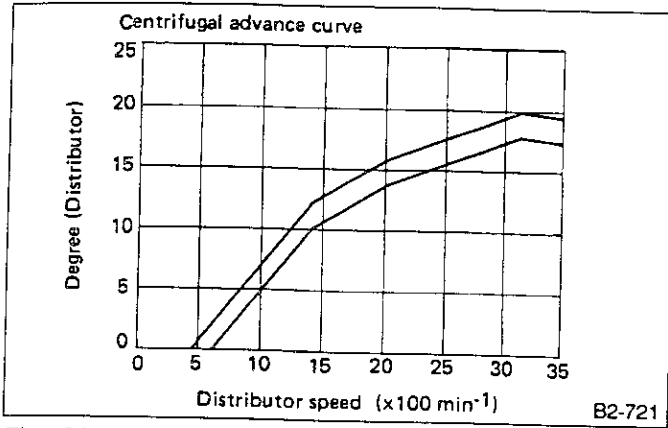


Fig. 22

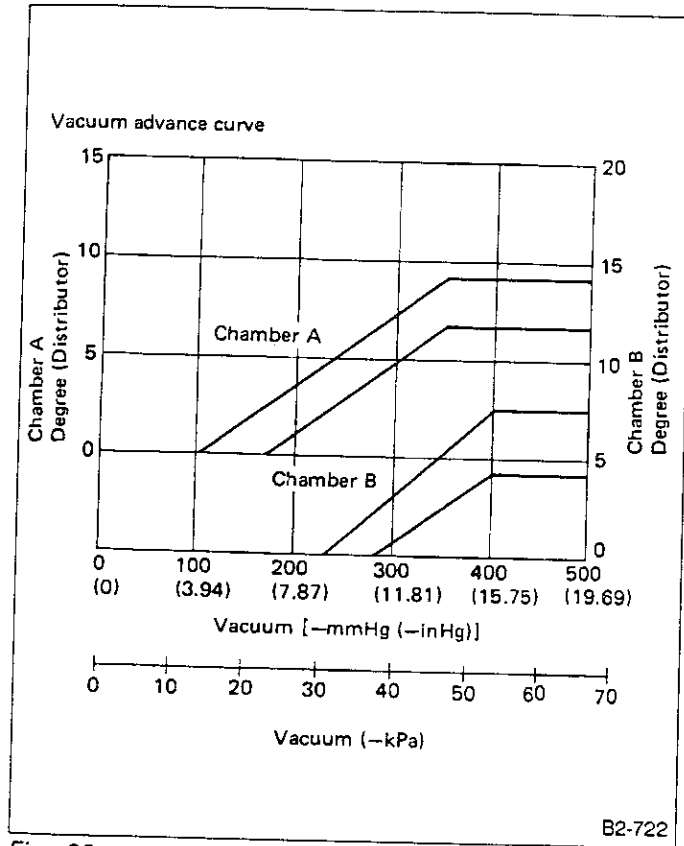


Fig. 23

8. Evaporative Emission Control System

A: DESCRIPTION

1. GENERAL

The evaporative emission control system is employed to prevent evaporative fuel from being discharged into ambient atmosphere. This system includes a canister, purge control solenoid valve or thermo valve, a fuel separator, their connecting lines, etc.

Gasoline vapor evaporated from the fuel in the fuel tank is introduced into the canister located in the engine compartment through the evaporation line, and is absorbed on activated carbon in it. A fuel separator is also incorporated on the tank fuel line.

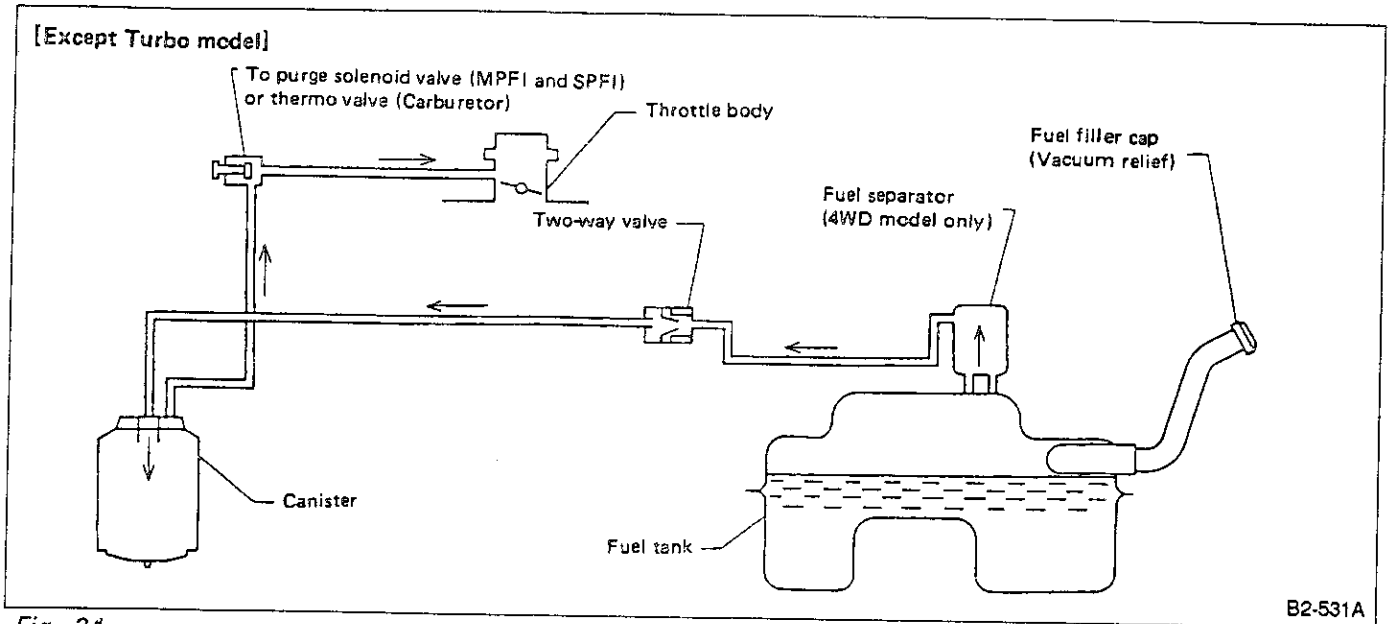


Fig. 24

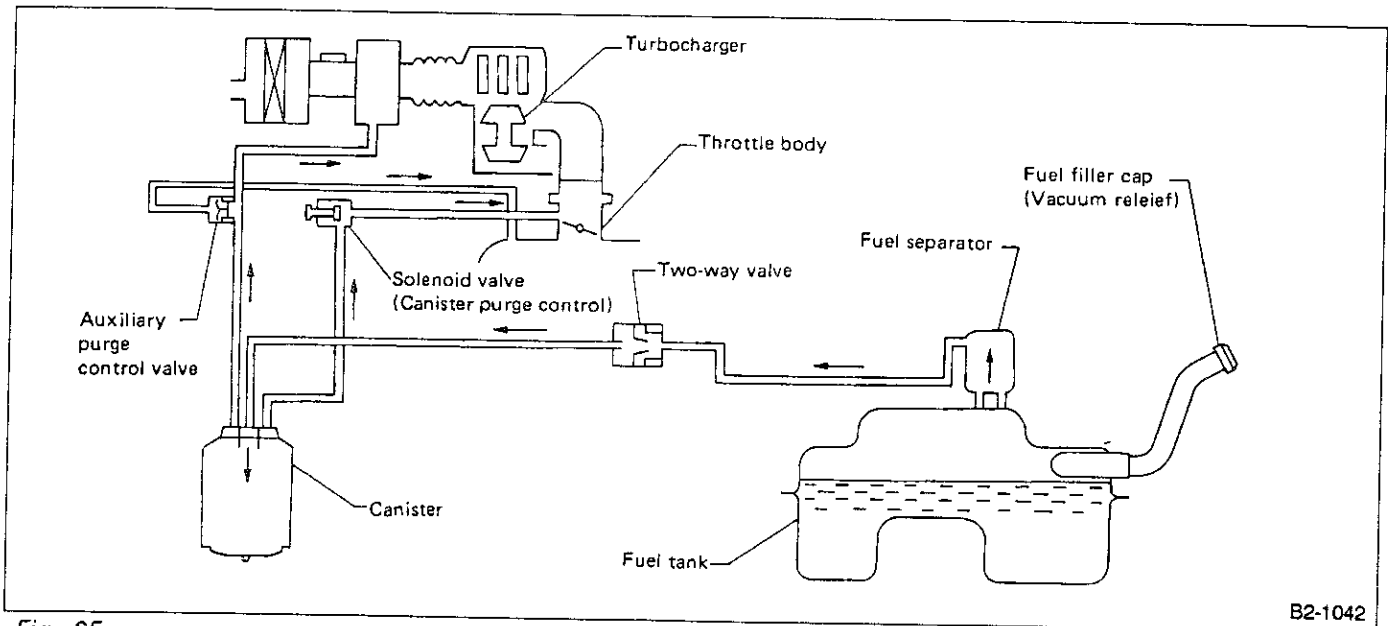


Fig. 25

2. PURGE CONTROL LINE

[MPFI and SPFI model]

The purge control solenoid valve is controlled by the ECU and provides optimal purge control according to the coolant temperature, engine speed and vehicle speed.

On TURBO models, the auxiliary purge control valve is situated between the canister and the resonator chamber. It is opened by vacuum pressure produced in the intake manifold when the engine is not supercharged.

[Carburetor model]

When the coolant temperature reaches the specified value, the purge control thermo valve opens the purge line so that evaporative gas is delivered from the canister to the carburetor throttle bore.

3. CARBURETOR VAPOR LINE

The carburetor vapor line, connecting between the carburetor float chamber and the canister, is employed in addition to the tank vapor line. Gasoline vapor evaporated from the float chamber is inducted into the canister through the switch vent solenoid valve at all positions except "ON" and "START" positions of ignition-starter switch.

4. CANISTER

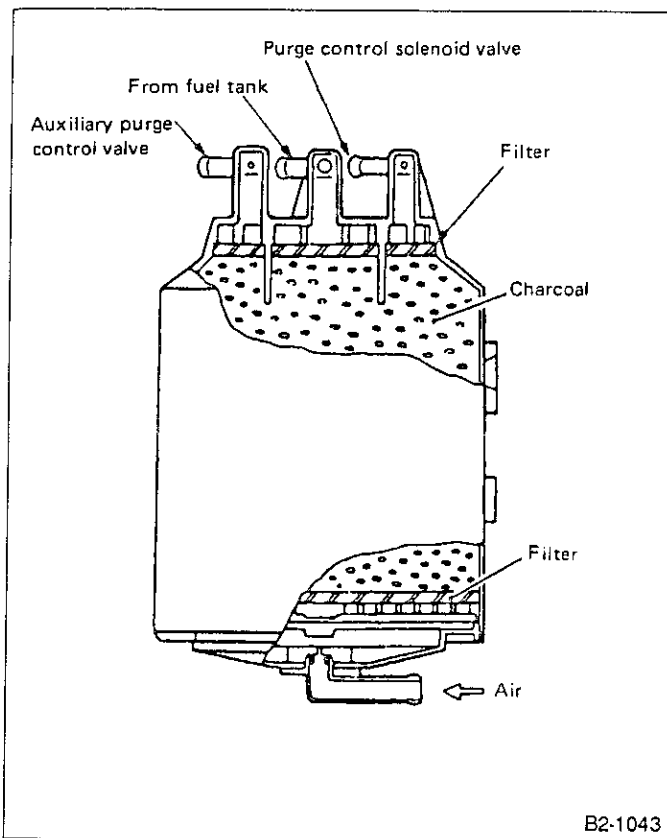


Fig. 26

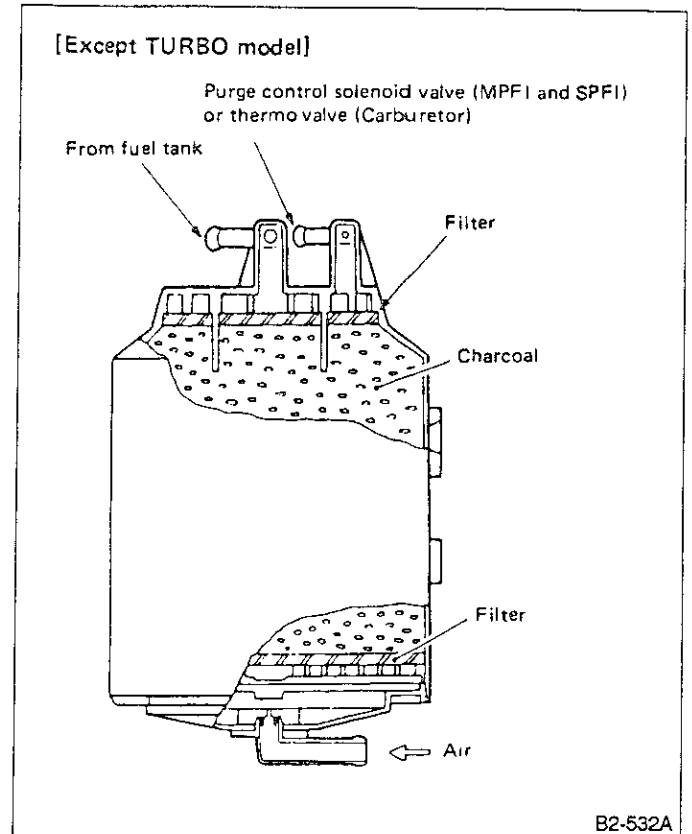
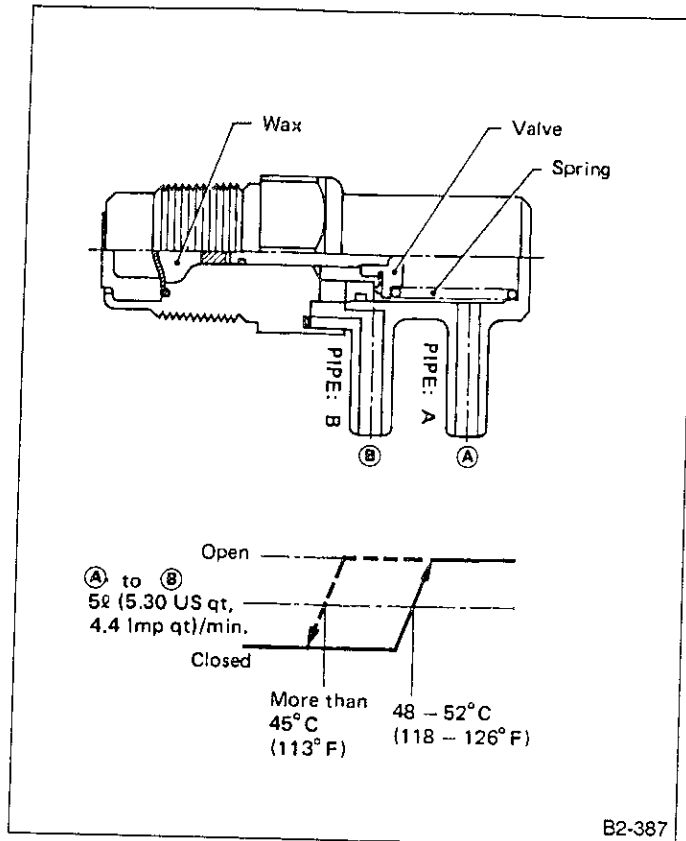


Fig. 27

5. THERMO VALVE



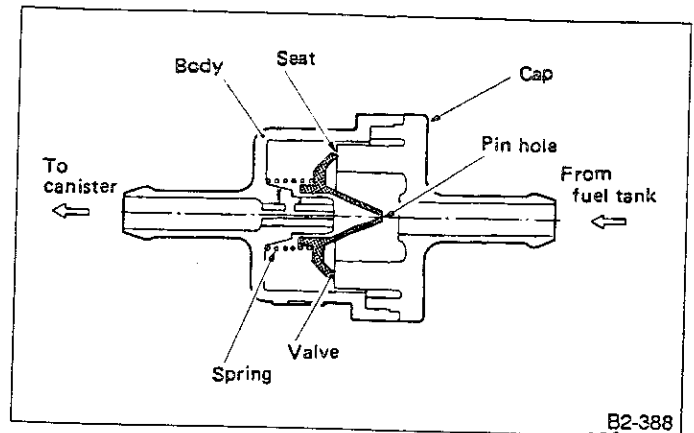
6. TWO-WAY VALVE

The two-way valve is placed in the fuel vapor line between the fuel tank and canister. When fuel tank pressure exceeds the specified value, evaporative gas is discharged to the canister via the two-way valve; when it drops below the specified value, atmospheric air is introduced into the fuel tank. In this way, internal tank pressure is maintained within the specified range to prevent deformation of the fuel tank.

When internal fuel tank pressure exceeds the specified value, the valve is pressurized to push the spring. This lifts the valve seat so that evaporative gas is discharged to the canister.

When internal fuel tank vacuum pressure exceeds the specified value, the valve moves in the right direction to close the valve seat. However, air which enters from the

inlet port of the canister is introduced into the fuel tank through the pin hole located at the end of the valve.



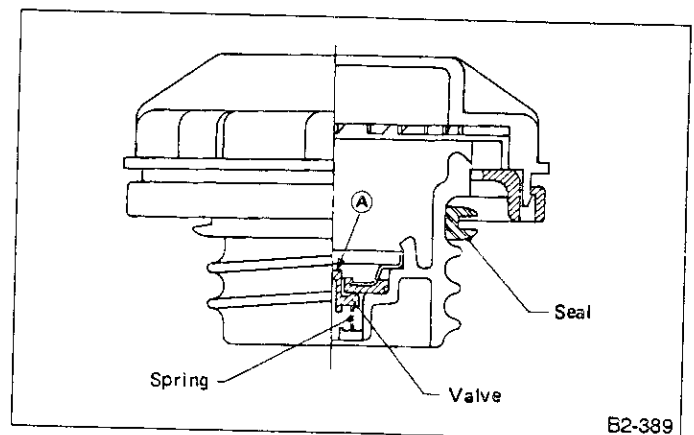
7. FUEL SEPARATOR

The fuel separator is to prevent liquid fuel from flowing into the canister in case of abrupt cornering, etc.

8. FUEL CAP

The relief valve is adopted to prevent the development of vacuum in the fuel tank which may occur in case of trouble in the fuel vapor line.

In normal condition, the filler pipe is sealed at A and at the packing pressed against the filler pipe end. As vacuum develops in the fuel tank, atmospheric pressure forces the spring down to open the valve; consequently air is led into the fuel tank controlling the inside pressure.



B: INSPECTION**1. EVAPORATION LINE**

- 1) Remove fuel filler cap.
- 2) Disconnect evaporation hose from canister and disconnect evaporation hose from 2-way valve. Check for unobstructed evaporation line by blowing air into hose.
- 3) Disconnect purge hose from canister. Blow air through hose to ensure that air does not leak.

Be careful not to suck on the hose as this causes fuel evaporating gas to enter your mouth.

- 4) Check the exterior of the canister to ensure that it is not cracked or scratched.

2. TWO-WAY VALVE

- 1) Check for slight resistance in the air passage due to the valve by blowing air into the nipple on the canister side.
- 2) Check for resistance in the air passage due to the valve by blowing air into the nipple on the fuel tank side.

3. THERMO VALVE

Connect vinyl tube to each nipple of thermo valve and blow air into the valve to make sure that the valve opens and closes at the specified temperatures as shown in the table below.

If any item in the table is not satisfied, replace valve with a new one.

Above 50°C (122°F)	Open
Below 45°C (113°F)	Closed

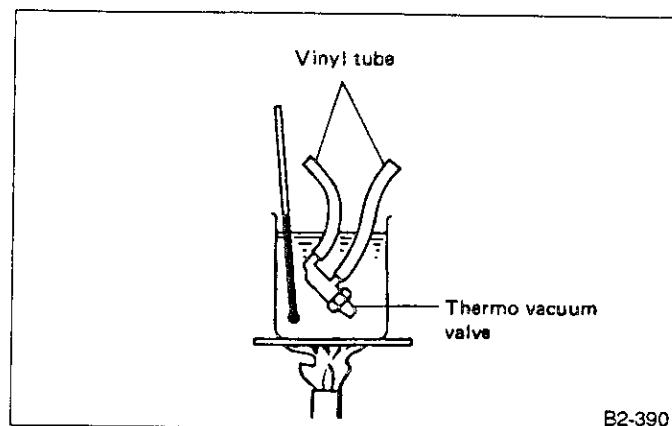


Fig. 31

9. Vacuum Fitting

1. 2200cc MPFI AND 2000cc MPFI NON-TURBO

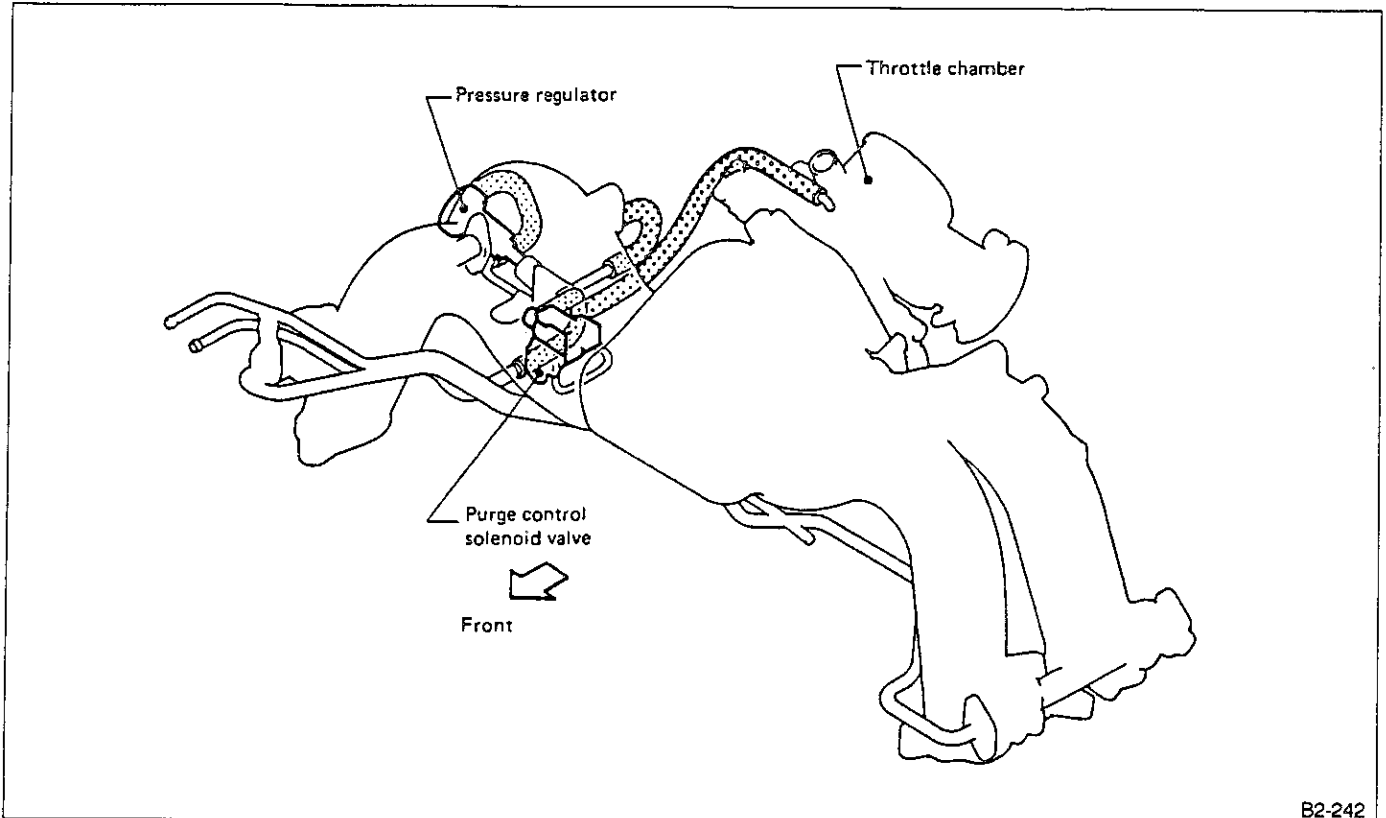


Fig. 32

2. 2000cc MPFI TURBO model

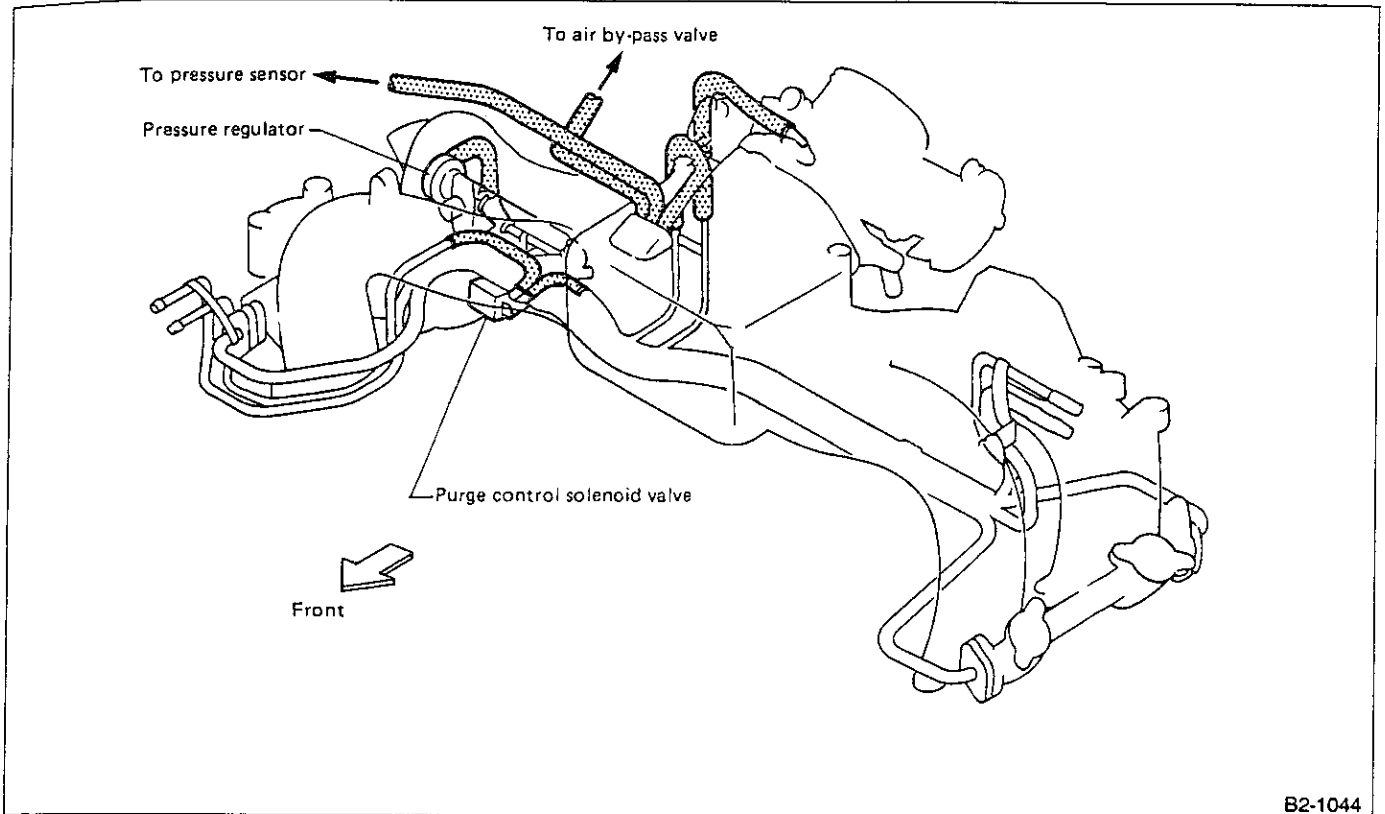


Fig. 33

3. 1800cc SPFI

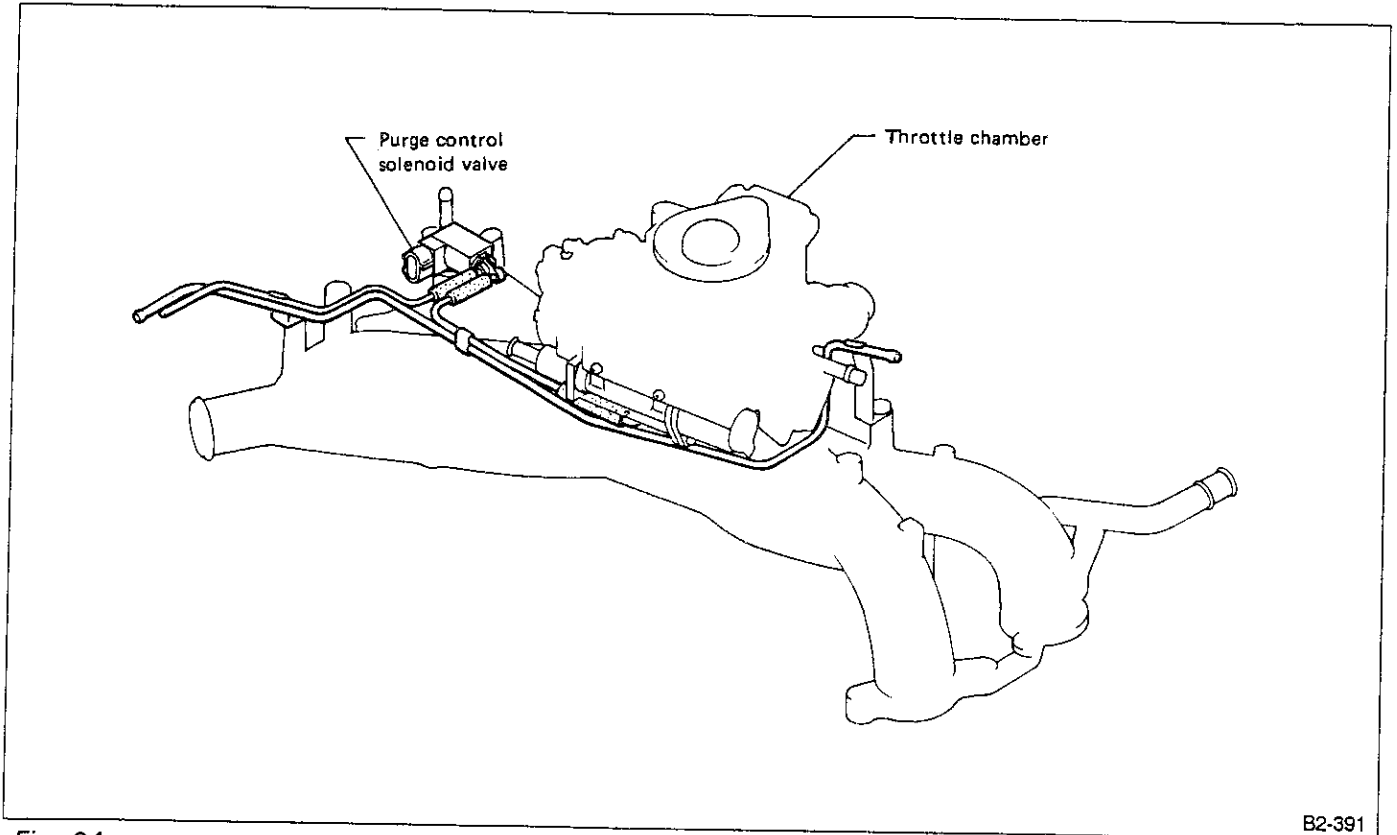


Fig. 34

4. 1800cc CARBURETOR (4AT)

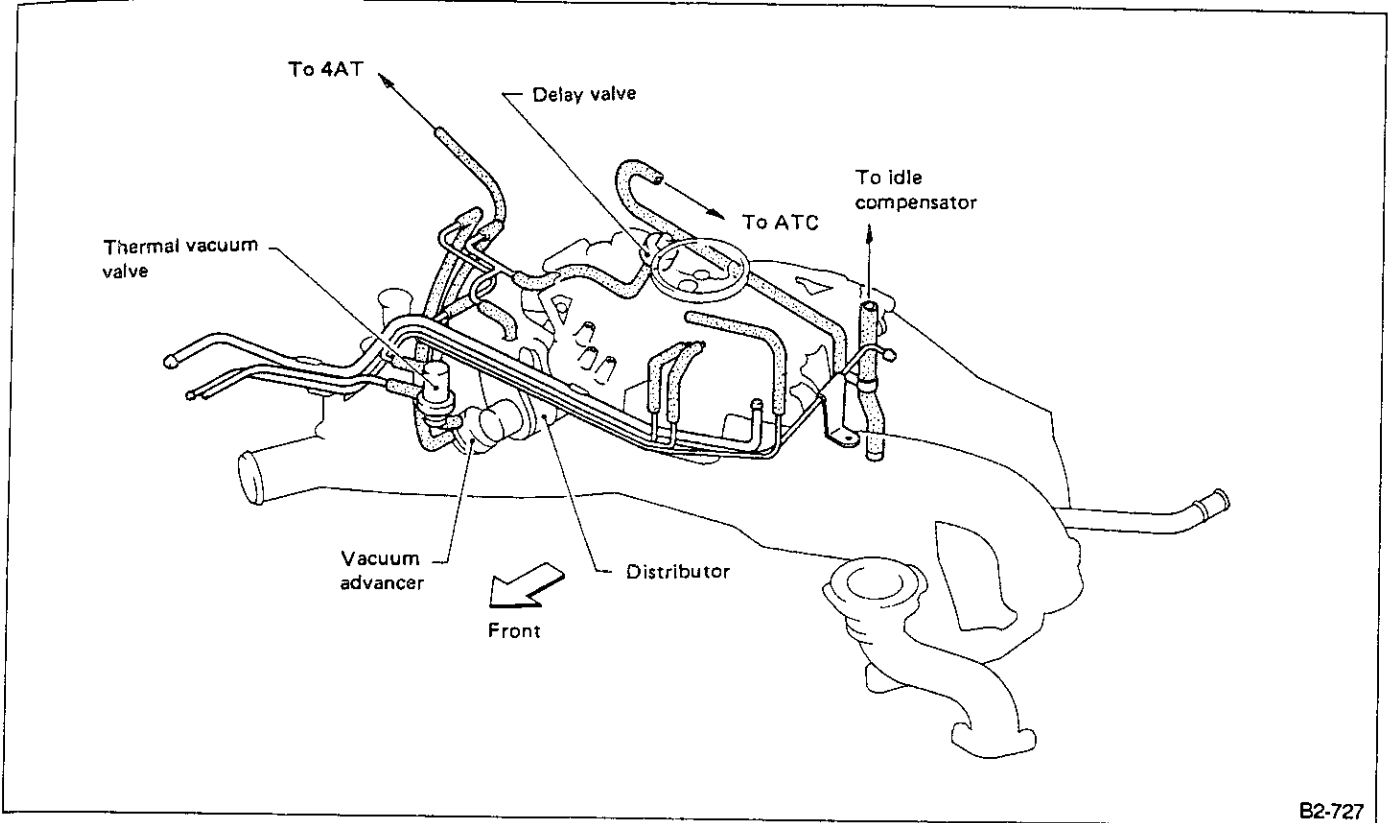


Fig. 35

B2-727

5. 1800cc CARBURETOR (MT, 3AT) and 1600cc CARBURETOR

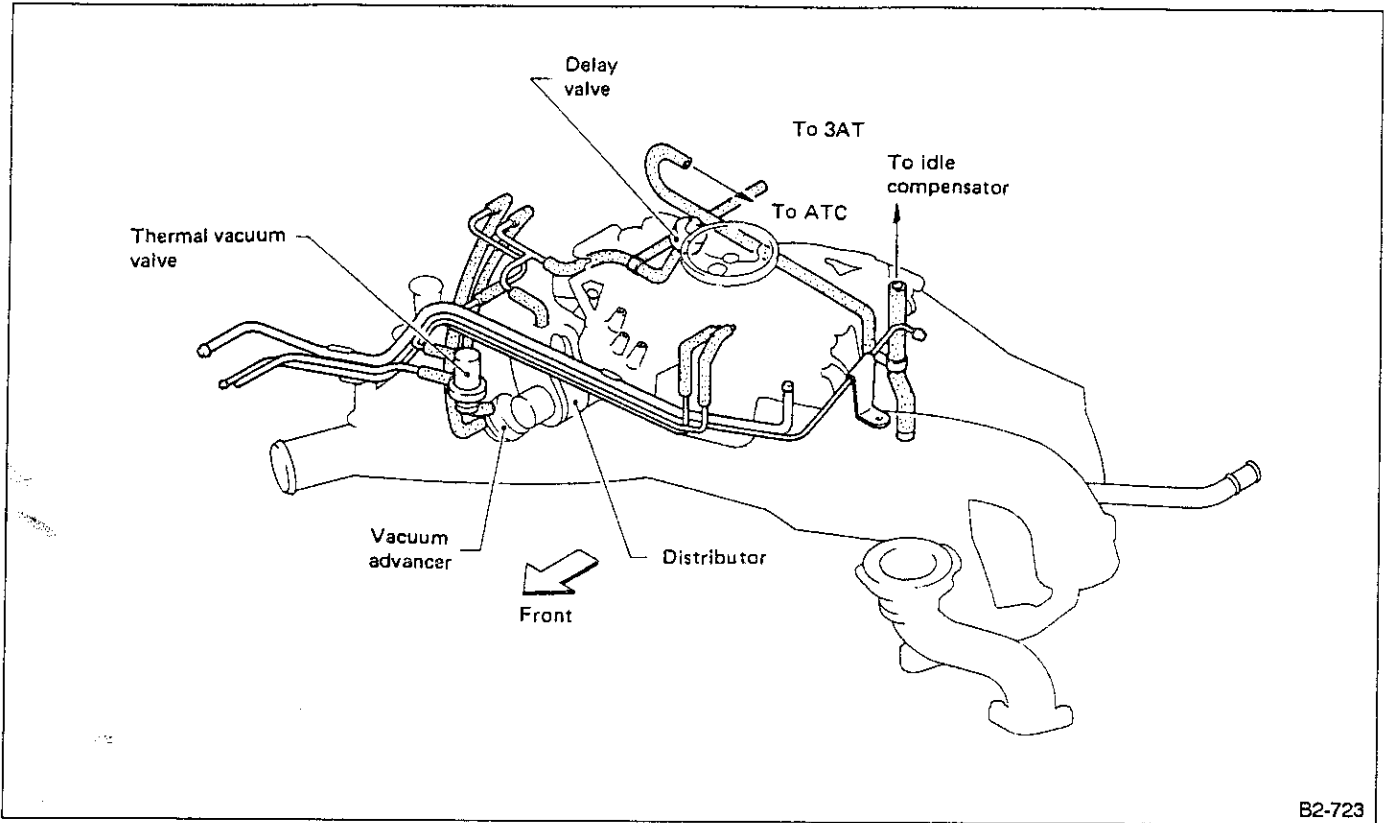


Fig. 36

SUBARU®

1992

**SERVICE
MANUAL**

	Page
1. Foreword	2
2. Ignition Timing	2
3. Engine Idle Speed	3
4. Engine Compression	3
5. Intake Manifold Vacuum	4
6. Hydraulic Lash Adjuster	5
7. Fuel Injector	6
8. Oxygen (O ₂) Sensor	7
9. Hot Air Control System	8
10. Idle Compensator	9



1. Foreword

This chapter describes major inspection and service procedures for the engine mounted on the body. For procedures not found in this chapter, refer to the service procedure section in the applicable chapter.

2. Ignition Timing

A: INSPECTION

1. 2200 cc MPFI, 2000 cc MPFI NON-TURBO AND 1800 cc SPFI

- 1) Warm up the engine.
- 2) Confirm that the idle switch is ON.
- 3) To check the ignition timing, connect a timing light to #1 cylinder spark plug cord, and illuminate the timing mark with the timing light.

Ignition timing [BTDC/rpm]:

2200 cc MPFI	$23^{\circ} \pm 10^{\circ}/800$
2000 cc MPFI NON-TURBO	$23^{\circ} \pm 10^{\circ}/800$
1800 cc SPFI	$20^{\circ} \pm 10^{\circ}/850(\text{MT})$
	$20^{\circ} \pm 10^{\circ}/800(\text{AT})$

Ignition timing can be observed using select monitor. (Function mode "F07")

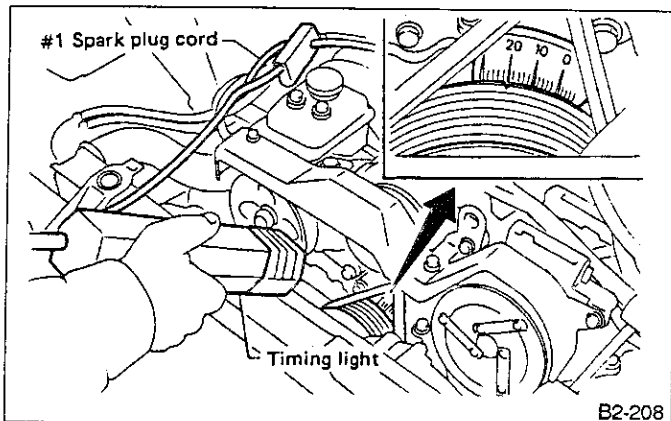


Fig. 1

2. 2000 cc MPFI TURBO

- 1) Warm up the engine.
- 2) Confirm that the idle switch is ON.
- 3) Connect "Select Monitor" and observe ignition timing. (Function mode "F07")

Ignition timing [BTDC/rpm]:

2000 cc MPFI TURBO	$18^{\circ} \pm 10^{\circ}/900$
--------------------	---------------------------------

3. 1800 cc CARBURETOR AND 1600 cc CARBURETOR

- 1) Warm up the engine.
- 2) Ensure that vacuum hose is properly connected to distributor vacuum advancer.
- 3) To check the ignition timing, connect a timing light to #1 cylinder spark plug cord, adjust the engine idle speed to the specification and illuminate the timing mark with the timing light.

Ignition timing [BTDC/rpm]:

1800 cc Carburetor	$20^{\circ} \pm 5^{\circ}/800$
1600 cc Carburetor	$20^{\circ} \pm 5^{\circ}/900$

B: ADJUSTMENT

1. 2200 cc MPFI, 2000 cc MPFI (TURBO AND NON-TURBO) AND 1800 cc SPFI

If the timing is not correct, check the ignition control system. (Refer to "2-7 Fuel Injection System".)

2. 1800 cc CARBURETOR AND 1600 cc CARBURETOR

- 1) Loosen the 8 mm bolt(s) securing distributor.
- 2) Turn the distributor housing. The timing is advanced when the distributor housing is turned clockwise and is retarded when turned counterclockwise.
- 3) Tighten the bolt(s) and make sure that the timing is correct.

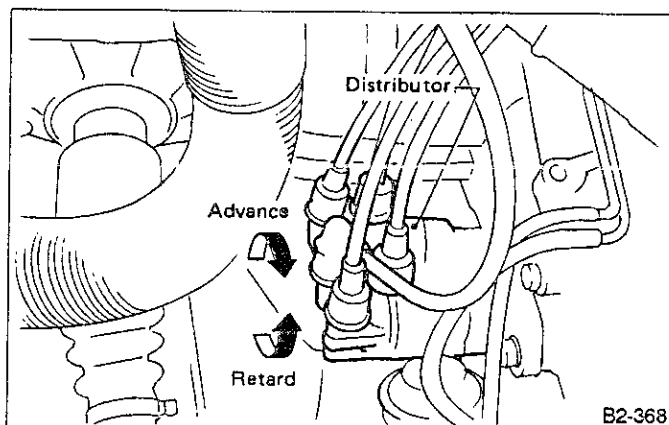


Fig. 2

- 4) Adjust the engine idle speed.

3. Engine Idle Speed

A: INSPECTION

1. EXCEPT 2000 cc MPFI TURBO

- 1) Before checking idle speed, check the following:
 - (1) Ensure that air cleaner element is free from clogging, ignition timing is correct, spark plugs are in good condition, and that hoses are connected properly.
 - (2) Ensure that CHECK ENGINE light is off (Except 1800 cc Carburetor and 1600 cc Carburetor models).
- 2) Warm up the engine.
- 3) Attach the pickup sensor on tachometer (Secondary pickup type) to #1 plug cord.

The ignition system of the 2200 cc MPFI model provides simultaneous ignition for #1 and #2 plugs. It must be noted that some tachometers may register twice that of actual engine speed.

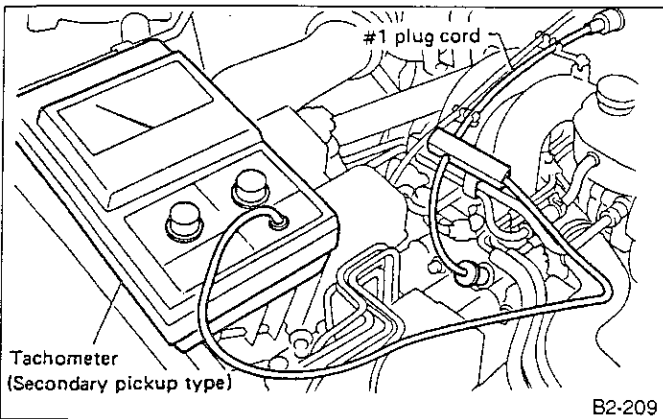


Fig. 3

- 4) Check idle speed when unloaded (with headlights, heater fan, rear defroster, radiator fan, air conditioner, etc. OFF).

Idle speed (No load and gears in neutral position):

- 2200 cc MPFI 800 ± 100 rpm
- 2000 cc MPFI NON-TURBO 800 ± 100 rpm
- 1800 cc SPFI 850 ± 100 rpm (MT)
- 800 ± 100 rpm (AT)
- 1800 cc Carburetor 800 ± 50 rpm
- 1600 cc Carburetor 900 ± 50 rpm

- a. If idle speed is outside specifications, refer to General Troubleshooting chart under "2-7 Fuel Injection System" (MPFI and SPFI model), or "1-5 Periodic Maintenance Services" (Carburetor model).
- b. On MPFI and SPFI models, engine speed can be observed using select monitor (Function mode "F04").

2. 2000 cc MPFI TURBO

- 1) Before checking idle speed, check the following:
 - (1) Ensure that air cleaner element is free from clogging, ignition timing is correct, spark plugs are in good condition, and that hoses are properly connected.
 - (2) Ensure that CHECK ENGINE light is off.
- 2) Warm up the engine.
- 3) Connect "Select Monitor" and observe engine rpm. (Function mode "F04")
- 4) Check idle speed when unloaded (with headlights, heater fan, rear defroster, radiator fan, air conditioner, etc. OFF).

Idle speed (No load and gears in neutral position):
 2000 cc MPFI TURBO
 900 ± 100 rpm

If idle speed is outside specifications, refer to General Troubleshooting chart under "2-7 Fuel Injection System".

4. Engine Compression

A: MEASUREMENT

- 1) After warming up the engine, turn off the ignition-starter switch.
 - 2) Make sure that the battery is fully charged.
 - 3) Remove all ignition coils. (TURBO model only) (Refer to "6-1 Ignition coil [W5A2]").
 - 4) Remove all the spark plugs.
 - 5) Disconnect connectors from fuel injector.
 - 6) Fully open the throttle valve.
 - 7) Check the starter motor for satisfactory performance and operation.
 - 8) Crank the engine by means of the starter motor, and read the maximum value on the gauge when the pointer is steady.
- Hold the compression gauge tight against the spark plug hole.
- 9) Perform at least two measurements per cylinder, and make sure that the values are correct.

Compression

(200 — 300 rpm and fully open throttle):

Standard

2200 cc

1,079 — 1,275 kPa

(11.0 — 13.0 kg/cm², 156 — 185 psi)

2000 cc NON-TURBO

1,079 — 1,275 kPa

(11.0 — 13.0 kg/cm², 156 — 185 psi)

2000 cc TURBO

981 — 1,177 kPa

(10.0 — 12.0 kg/cm², 142 — 171 psi)

1800 cc

981 — 1,177 kPa

(10.0 — 12.0 kg/cm², 142 — 171 psi)

1600 cc

883 — 1,079 kPa

(9.0 — 11.0 kg/cm², 128 — 156 psi)**Limit**

2200 cc

883 kPa (9.0 kg/cm², 128 psi)

2000 cc NON-TURBO

883 kPa (9.0 kg/cm², 128 psi)

2000 cc TURBO

834 kPa (8.5 kg/cm², 121 psi)

1800 cc

785 kPa (8.0 kg/cm², 114 psi)

1600 cc

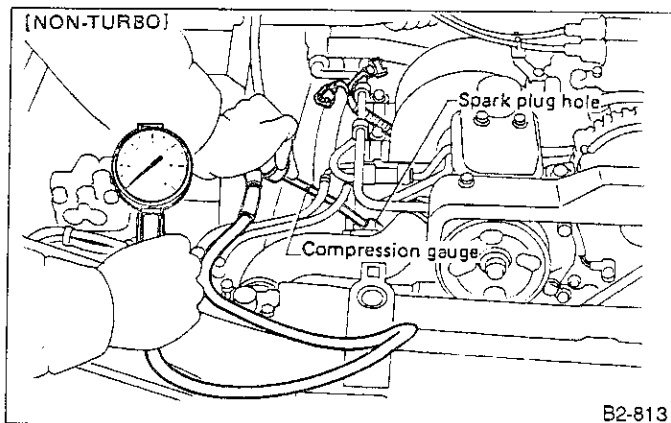
686 kPa (7.0 kg/cm², 100 psi)**Difference between cylinders**196 kPa (2.0 kg/cm², 28 psi)

Fig. 4

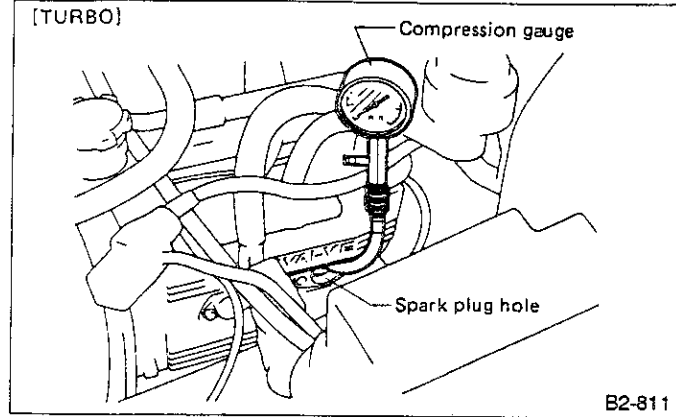


Fig. 5

5. Intake Manifold Vacuum**A: MEASUREMENT**

- 1) Warm up the engine.
- 2) Disconnect the vacuum hose and install the vacuum gauge to the hose fitting on the manifold.
- 3) Keep the engine at the idle speed and read the vacuum gauge indication.

By observing the gauge needle movement, the internal condition of the engine can be diagnosed as described in Table below.

Vacuum pressure (at idling)

2200 cc MPFI

More than - 66.7 kPa

(- 500 mmHg, - 19.69 inHg)

2000 cc MPFI NON-TURBO

More than - 69.3 kPa

(- 520 mmHg, - 20.47 inHg)

2000 cc MPFI TURBO

More than - 66.7 kPa

(- 500 mmHg, - 19.69 inHg)

1800 cc SPFI

More than - 60.0 kPa

(- 450 mmHg, - 17.72 inHg)

1800 cc Carburetor

More than - 58.7 kPa

(- 440 mmHg, - 17.32 inHg)

1600 cc Carburetor

More than - 58.7 kPa

(- 440 mmHg, - 17.32 inHg)

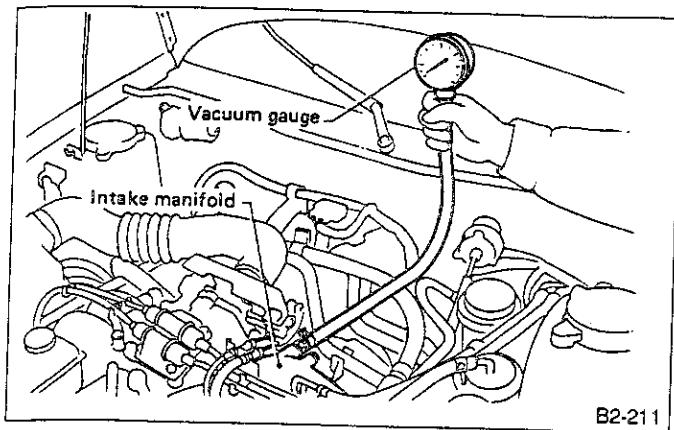


Fig. 6

B2-211

Diagnosis of engine condition by measurement of manifold vacuum	
Vacuum gauge indication	Possible engine condition
1. Needle is steady but lower than normal position. This tendency becomes more evident as engine temperature rises.	Leakage around intake manifold gasket or throttle chamber gasket.
2. When engine speed is reduced slowly from higher speed, needle stops temporarily when it is lowering or becomes steady above normal position.	Back pressure too high, or exhaust muffler clogged.
3. Needle intermittently drops to position lower than normal position.	Leakage around cylinder.
4. Needle drops suddenly and intermittently from normal position.	Sticky valves.
5. When engine speed is gradually increased, needle begins to vibrate rapidly at certain speed, and then vibration increases as engine speed increases.	Weak or broken valve springs.
6. Needle vibrates above and below normal position in narrow range.	Defective ignition system or throttle chamber idle adjustment (MPFI).

6. Hydraulic Lash Adjuster (SOHC model)

A: INSPECTION

- 1) Disconnect blow-by hose.
- 2) Remove plug cap.
- 3) Disconnect connectors from fuel injectors.

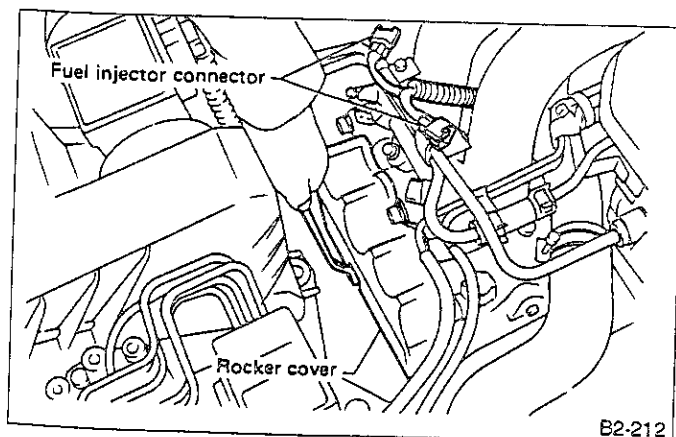


Fig. 7

B2-212

- 4) Remove left and right rocker covers.

Before removing left rocker cover, disconnect engine harness connector, battery cables and alternator cable.

- 5) Manually push valve rocker (at lash adjuster location) to check that there is no air in it.

When air is in lash adjuster, valve rocker moves when pushed with fingers.

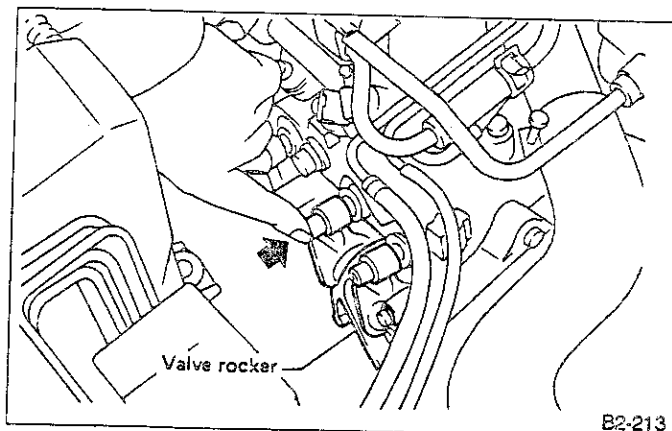


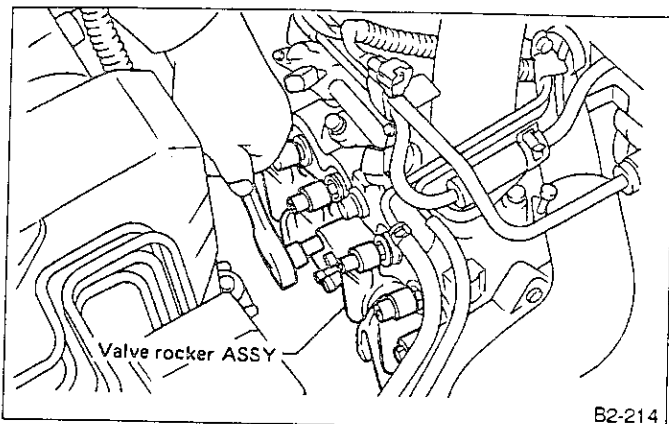
Fig. 8

B2-213

- 6) If air is in lash adjuster, remove valve rocker ASSY from engine and bleed air completely.

B: BLEEDING AIR FROM VALVE LASH ADJUSTER

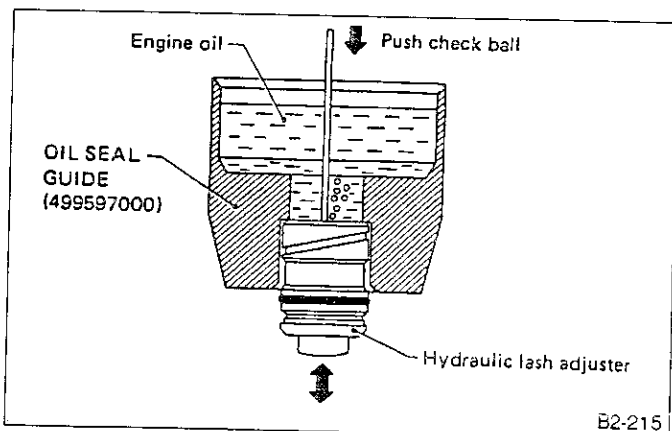
- 1) Remove valve rocker ASSY.



B2-214

Fig. 9

- 2) Manually remove lash adjusters where air is trapped. **If lash adjuster is difficult to remove manually, use pliers. Be careful not to scratch lash adjuster.**
- 3) Insert lash adjuster into OIL SEAL GUIDE as shown, and fill OIL SEAL GUIDE with engine oil. Using a 2 mm (0.08 in) dia. rod, push check ball in.



B2-215

Fig. 10

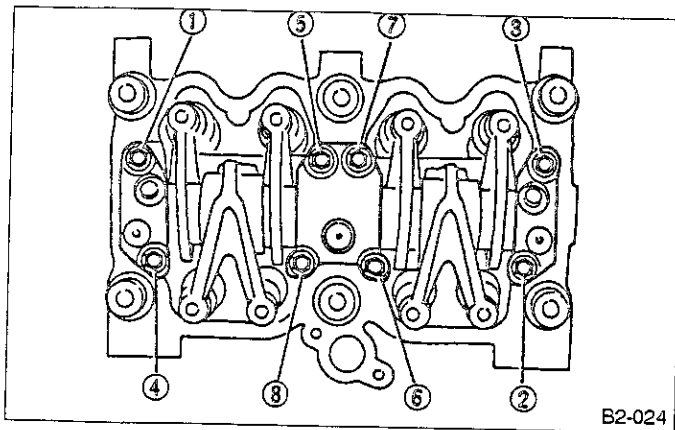
- 4) With check ball pushed in, push plunger at an interval of one second.
- 5) Move plunger up and down until air bubbles are no longer emitted from lash adjuster.
- 6) Remove the rod. Push plunger to ensure that air is completely bled out.

If plunger does not properly lock (when pushed), replace lash adjuster with a new one.

- 7) Fill rocker arm's oil reservoir with engine oil and install lash adjuster.

Do not rotate lash adjuster during installation.

- 8) Temporarily and equally tighten bolts ① through ④. Do not allow dowel pin to catch valve rocker ASSY.



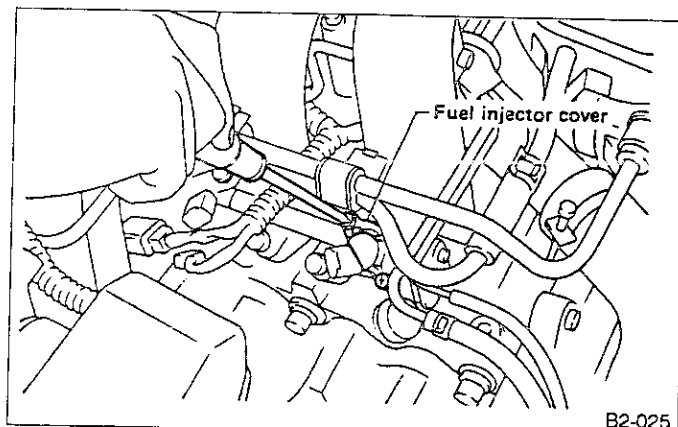
B2-024

Fig. 11

- 9) Tighten bolts ⑤ through ⑧ to specified torque.
- 10) Tighten bolts ① through ④ to specified torque.
- 11) Install rocker covers.
- 12) Connect harness connectors, hoses, etc. to their positions.

7. Fuel Injector (MPFI model)**A: REMOVAL**

- 1) Fuel pressure elimination
- (1) Disconnect fuel pump connector.
 - (2) Start engine.
 - (3) Run engine until it stalls.
 - (4) After it stalls, crank starter for approximately 5 seconds and turn ignition switch to "OFF".
- 2) Remove spark plug caps.
- 3) Disconnect connector from fuel injector.
- 4) Remove fuel injector cover.



B2-025

Fig. 12

- 5) Extract while turning fuel injectors.

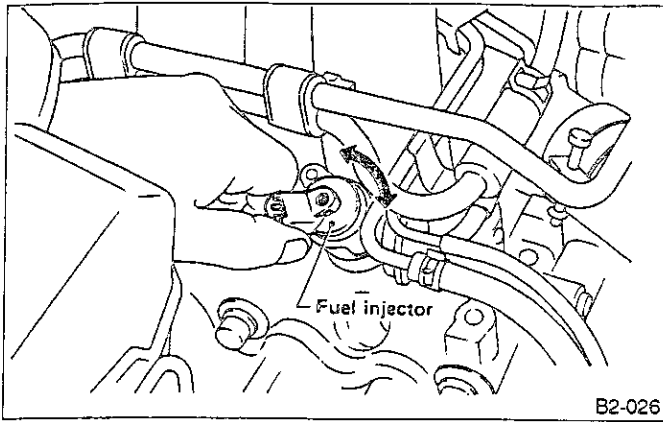


Fig. 13

- a. Do not attempt to pry injectors with a screwdriver or similar tool. Do not pinch injector pin with pliers.
 - b. Be careful not to damage O-ring.
 - c. If injector is difficult to remove with your hand, remove injector and fuel pipe as a unit, and push injector out from the back side.
- 6) To install, reverse order of removal procedures.

8. Oxygen (O₂) Sensor

A: REPLACEMENT

Oxygen (O₂) sensor is one of the important emission control parts. Therefore, replace it as follows only when it is damaged by external force, or if it seems to be out of order according to troubleshooting etc.

1. 2200 cc MPFI CATALYST, 2000 cc MPFI NON-TURBO AND 1800 cc SPFI MODEL

REMOVAL

- 1) Disconnect O₂ sensor cord.
- 2) Apply SUBARU CRC (004301003) or its equivalent to threaded portion of oxygen (O₂) sensor, and leave it for one minute or more.
- 3) Loosen oxygen (O₂) sensor by turning it 10 to 40 degrees with special tool (SOCKET: 499990110) and wrench.

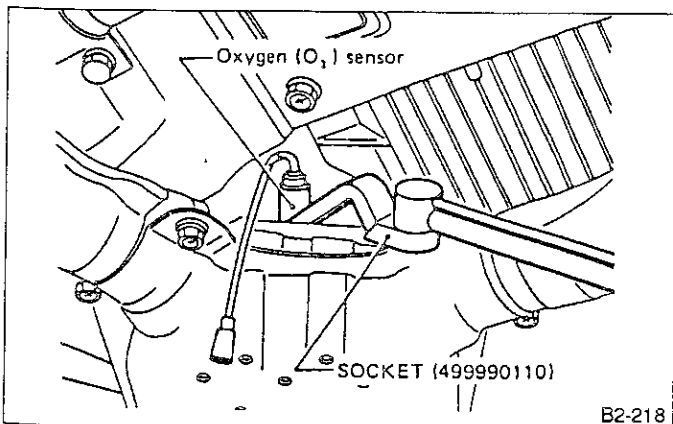


Fig. 14

- 4) Apply SUBARU CRC (004301003) to threaded portion of oxygen (O₂) sensor again, and leave it for one minute or more.
- 5) Remove oxygen (O₂) sensor by using socket and wrench.

When removing, do not force oxygen (O₂) sensor especially when exhaust pipe is cold; otherwise it will damage the exhaust pipe.

INSTALLATION

- 1) Apply anti-seize compound ("SS-30" made by JET-LUBE Inc. in U.S.A. or its equivalent) only to threaded portion of oxygen (O₂) sensor to make the next removal easier.

Never apply anti-seize compound to protector of oxygen (O₂) sensor.

- 2) By using socket and torque wrench, install oxygen (O₂) sensor onto front exhaust pipe by tightening it to the specified torque.

Torque [oxygen (O₂) sensor]:

25 — 34 N·m (2.5 — 3.5 kg-m, 18 — 25 ft-lb)

- 3) Securely connect oxygen (O₂) sensor cord.

2. 2000 cc MPFI TURBO MODEL

REMOVAL

- 1) Disconnect O₂ sensor cord.
- 2) Apply SUBARU CRC (004301003) or its equivalent to threaded portion of oxygen (O₂) sensor, and leave it for one minute or more.
- 3) Loosen oxygen (O₂) sensor by turning it 10 to 40 degrees.

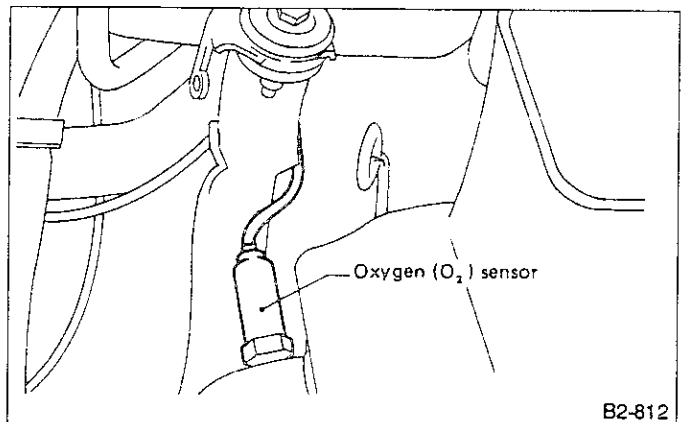


Fig. 15

- 4) Apply SUBARU CRC (004301003) to threaded portion of oxygen (O₂) sensor again, and leave it for one minute or more.
- 5) Remove oxygen (O₂) sensor.

When removing, do not force oxygen (O₂) sensor especially when exhaust pipe is cold; otherwise it will damage the exhaust pipe.

INSTALLATION

1) Apply anti-seize compound ("SS-30" made by JET-LUBE Inc. in U.S.A. or its equivalent) only to threaded portion of oxygen (O₂) sensor to make the next removal easier.

Never apply anti-seize compound to protector of oxygen (O₂) sensor.

2) By using torque wrench, install oxygen (O₂) sensor onto center exhaust pipe by tightening it to the specified torque.

Torque [oxygen (O₂) sensor]:

25 — 34 N·m (2.5 — 3.5 kg-m, 18 — 25 ft-lb)

3) Securely connect oxygen (O₂) sensor cord.

9. Hot Air Control System [Carburetor model (Except G.C.C. model)]

A: INSPECTION

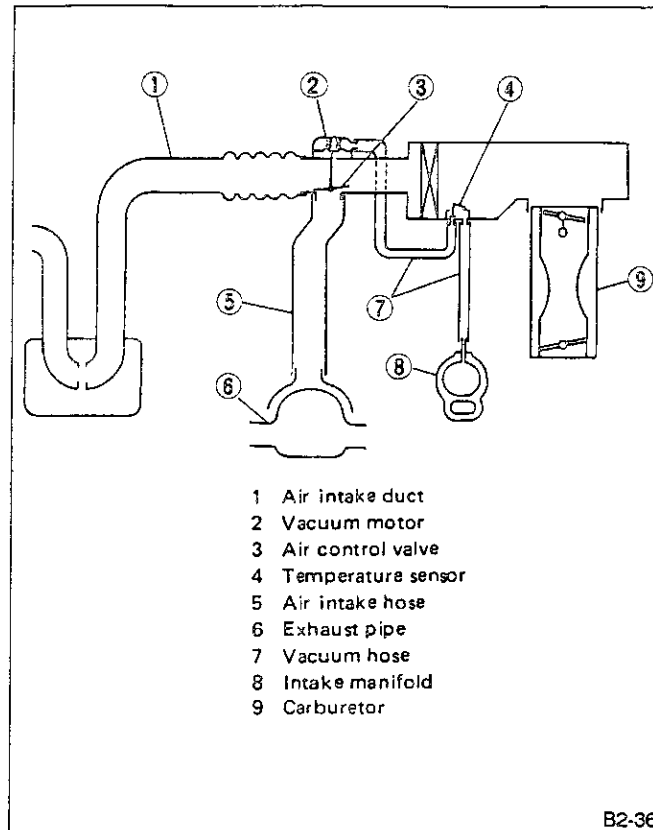
1. HOT AIR CONTROL SYSTEM

Inspect the hot air control system periodically as follows:

In warm weather, it is difficult to find out malfunction of the hot air control system. In cold weather, however, malfunction of the air control valve due to disconnection or deterioration of the vacuum hose between the intake manifold and vacuum motor and insufficient durability of the air control valve will cause insufficient automatic control operation for intake air, and result in engine disorders:

- 1) Stall or hesitation of engine operation,
- 2) Increase in fuel consumption, and
- 3) Lack of power.

These phenomena reveal malfunction of hot air control system. If these phenomena should occur, check the hot air control system for the following items before carrying out inspection of the carburetor.



- 1 Air intake duct
- 2 Vacuum motor
- 3 Air control valve
- 4 Temperature sensor
- 5 Air intake hose
- 6 Exhaust pipe
- 7 Vacuum hose
- 8 Intake manifold
- 9 Carburetor

B2-36

Fig. 16

2. VACUUM HOSES

Check each hose for cracks and proper connections.

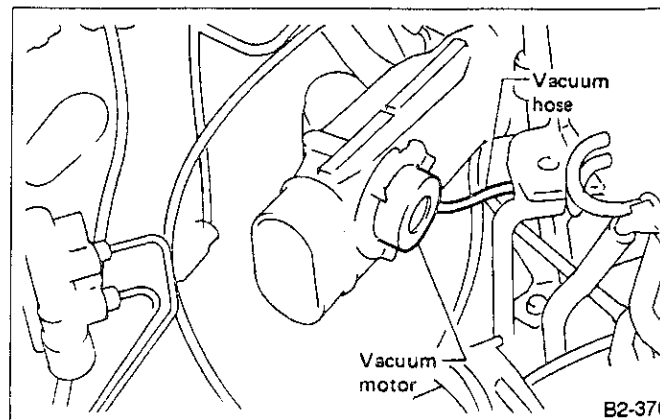
3. VACUUM MOTOR

1) With the engine stopped, remove air intake duct and check to see if the air control valve is in correct position.

The air control valve is in correct position if its under hood air inlet is open and hot air inlet is closed. Check the condition of the air control valve linkage.

2) Disconnect the vacuum motor inlet vacuum hose and connect another hose to the inlet to apply vacuum to the vacuum motor. Vacuum can be applied by sucking at the hose end.

Check to see if the air control valve is in correct position.



B2-37

Fig. 17

Correct position of the air control valve is the reverse of that described in 1) above. The air control valve is in correct position if the under hood air inlet is closed, and the hot air inlet is open.

3) With the hot air inlet in open position, as described in 2), pinch the vacuum hose with fingers so that the air does not enter the vacuum motor. In this condition,

check that the air control valve maintains the condition described in 2) for more than 30 seconds, and that the hot air inlet is open. If the diaphragm spring actuates the air control valve by its spring force to open the under hood air inlet within 30 seconds, replace the vacuum motor as an ASSY since this may have resulted from air leak at the vacuum motor diaphragm.

Operation of air control valve and sensor valve			
Air temperature	Vacuum on vacuum motor diaphragm	Air control valve operation	Sensor valve operation
Below 22°C (72°F)	Below 12.0 kPa (90 mmHg, 3.54 inHg)	Cold air admission	Closed
	Above 22.7 kPa (170 mmHg, 6.69 inHg)	Hot air admission	
22 — 39°C (72 — 102°F)	—	Cold and hot air mixture admission	Open
Above 39°C (102°F)	—	Cold admission	Open

4. TEMPERATURE SENSOR

Check temperature sensor for proper function by proceeding as follows. Be sure to keep the engine cold before starting this test.

1) With the engine stopped, check the position of the air control valve. In this case, underhood air inlet should be open. Use a mirror for inspection as 3-1).

2) Start the engine and keep it idling. Immediately after engine starting, check the air control valve for correct position as described above. In this case, the correct position of the air control valve is the reverse of 4-1); the underhood air inlet is closed, and the hot air inlet is open.

3) Check that the air control valve gradually moves to open the underhood air inlet as the engine warms up. When the environmental temperature around the temperature sensor is low, spend more time for engine warming up operation to facilitate smooth operation of the air control valve.

5. RUBBER PLATE

Check the rubber plate for stickiness.

6. AIR INTAKE HOSE

Check the air intake hose for damage and its connections for leaks.

10. Idle Compensator (Carburetor model)

A: FUNCTION

The idle compensator detects temperature of the intake air and, when the air temperature is high, it draws part of outside air directly into the intake manifold, thereby preventing air-fuel mixture from becoming rich and improving combustion characteristics at idle engine speed.

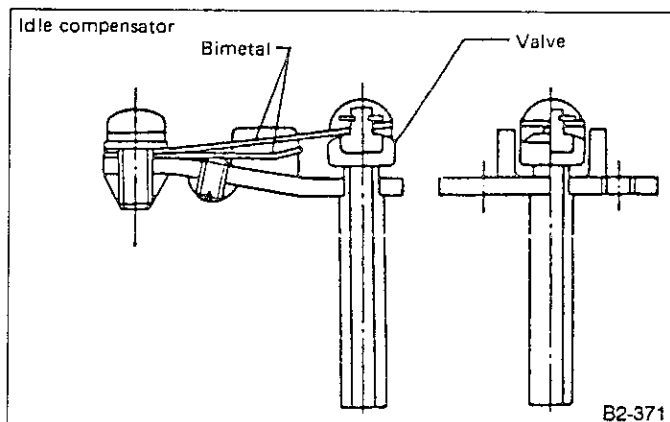


Fig. 18

B: INSPECTION

Check whether valve opens when idle compensator of air cleaner case is heated by a hair drier or the like. Check if valve is in closed position with temperature under 60°C (140°F).

SUBARU®**1992****SERVICE
MANUAL**

	Page
M MECHANISM AND FUNCTION	2
1. General	2
2. Timing Belt	3
3. Belt Tension Adjuster	3
4. Belt Cover	4
5. Valve Rocker ASSY	4
6. Hydraulic Lash Adjuster	5
7. Camshaft	5
8. Cylinder Head	6
9. Cylinder Block	6
10. Crankshaft	7
11. Piston	7
S SPECIFICATIONS AND SERVICE DATA	8
A: SPECIFICATIONS	8
B: SERVICE DATA	9
C COMPONENT PARTS	12
1. Timing Belt	12
2. Cylinder Head and Camshaft	13
3. Cylinder Head and Valve ASSY	14
4. Cylinder Block	15
5. Crankshaft and Piston	16
W SERVICE PROCEDURE	17
1. General Precautions	17
2. Timing Belt	17
3. Valve Rocker ASSY	26
4. Camshaft	30
5. Cylinder Head	35
6. Cylinder Block	43
T TROUBLESHOOTING	61
1. Engine Trouble in General	61
2. Engine Noise	64

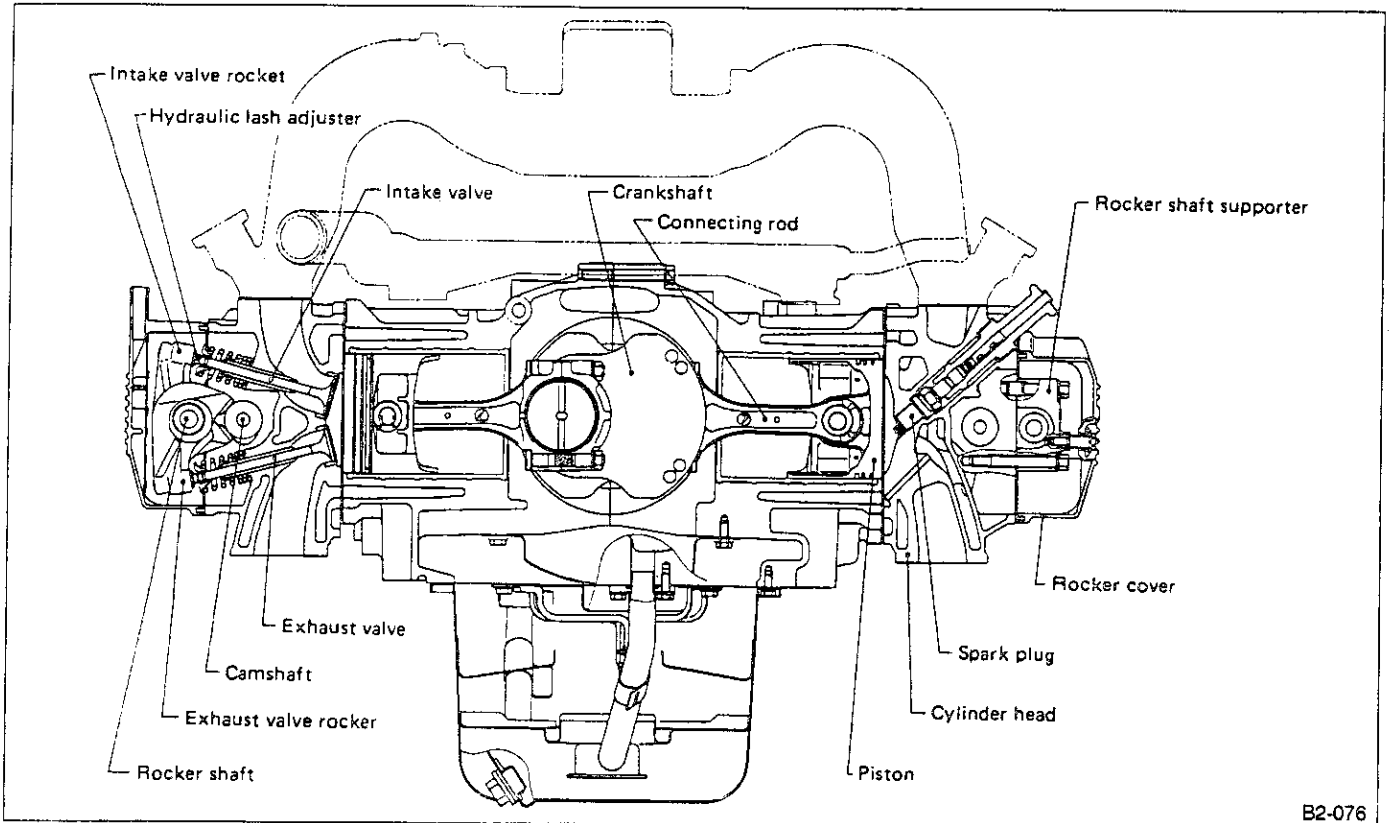
M MECHANISM AND FUNCTION

1. General

The engine is made from aluminum alloy and is horizontally opposed. It is a 4-stroke cycle, water-cooled, SOHC 16-valve engine.

A summary of the major construction and function features is as follows:

- The cylinder head is a center-plug type that utilizes pentroof combustion chambers. The four-valve design is provided with two intake valves and two exhaust valves per cylinder. The intake and exhaust ports are arranged in a cross-flow design.
- The valve rocker arm has a built-in hydraulic lash adjuster which eliminates the need for valve clearance adjustment.
- A single timing belt drives two camshafts on the left and right banks and the water pump on the left bank. Belt tension is automatically adjusted to eliminate maintenance.
- The crankshaft is supported by five bearings to provide high rigidity and strength.
- The cylinder block is made from aluminum diecast which is integrated with cast-iron cylinder liners.



B2-076

Fig. 1

2. Timing Belt

A single timing belt drives two camshafts (one in the left bank and one in the right bank). The back of the belt also drives the water pump.

The timing belt teeth have a specially designed round profile to provide quiet operation. The timing belt is

composed of a strong and inflexible core wire, a wear-resistant canvas and heat-resistant rubber material.

A hydraulic belt-tension adjuster constantly maintains specified belt tension to properly drive the camshafts, as well as to provide a "maintenance-free" advantage.

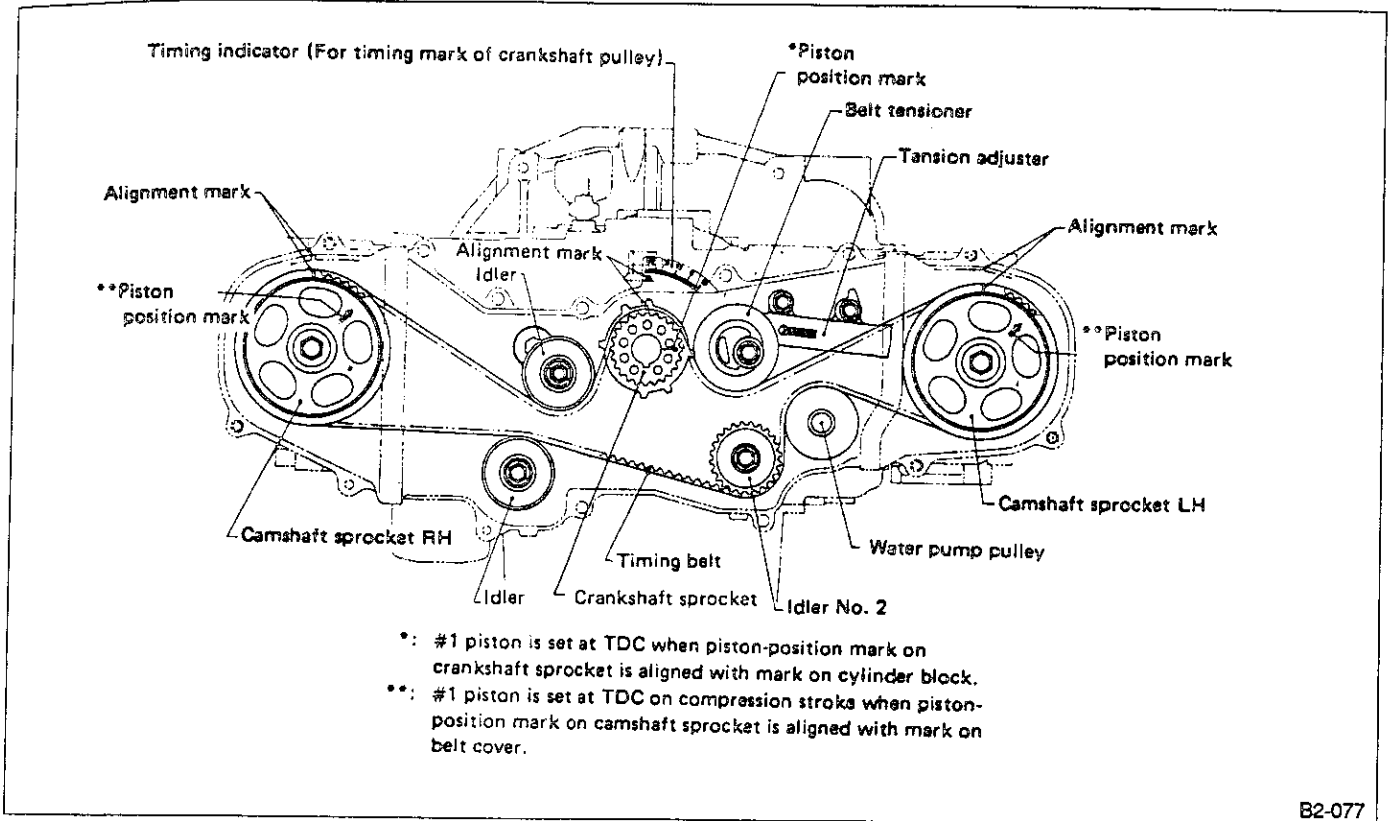


Fig. 2

3. Belt Tension Adjuster

The belt tension adjuster provides a constant value of tension for the timing belt. Proper belt tension is maintained using a rod to push the tension pulley. The location of the tensioner pulley shaft center is offset in relation to the center of the pulley's outside diameter.

The tensioner adjuster rod provides a rotary movement for the tensioner pulley by both tension of the spring housed in the adjuster.

1) Belt tension action

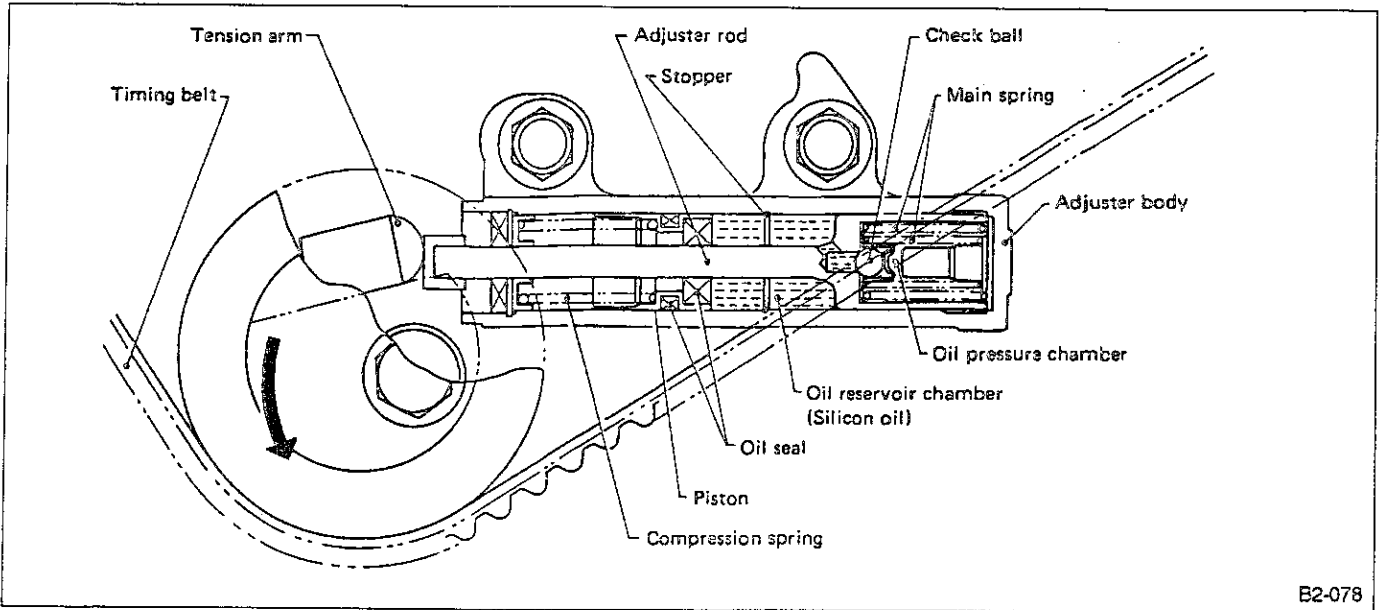
The tensioner adjuster rod is moved to the left by the force of the main spring. This causes silicon oil (which is held to constant pressure by compression-spring tension inside the reservoir chamber) to push the check ball so that silicon oil flows into the oil-pressure chamber.

The momentum which forces the adjuster rod out acts upon the tensioner arm so that the pulley is turned counterclockwise. Thus, timing belt tension is properly maintained.

2) Balance to belt tension

When the timing belt reaction force is balanced by the main spring tension (to push the adjuster rod), the arm is held stationary to maintain constant belt tension.

When the timing belt reaction force increases to such an extent that the belt will be too tight, a small quantity of oil in the oil-pressure chamber gradually returns to the reservoir chamber via the adjuster body-to-rod clearance. This return of oil continually moves the rod until the reaction force of the timing belt balances with main spring force and oil pressure inside the oil-pressure chamber. Thus, belt tension is constantly maintained.



B2-078

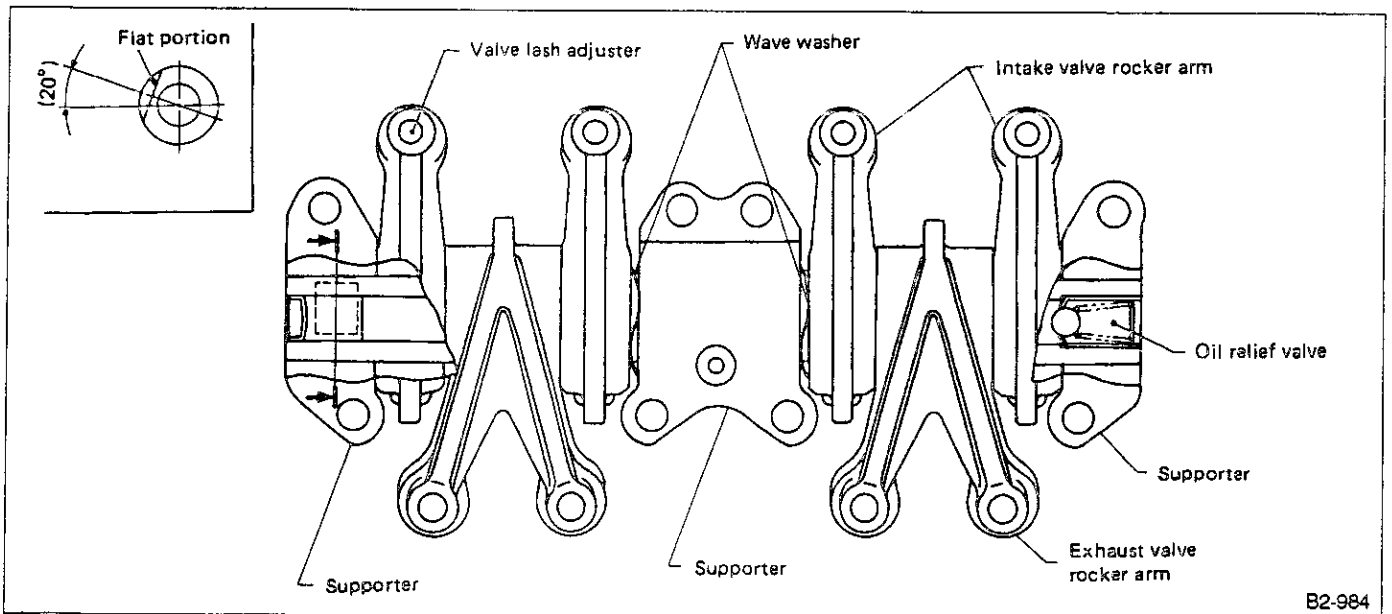
Fig. 3

4. Belt Cover

The belt cover is made of synthetic resin molding which is lightweight and heat resistant. It has a totally enclosed design that utilizes rubber packing at the mating surface of the cylinder block. This eliminates the chance of dust and water from entering the interior. A floating design is utilized by placing rubber mounting between the cylinder block and belt cover to prevent the transmission of noise and vibration. The front belt cover has a graduated line for ignition-timing confirmation.

A metal bushing is press-fitted to the rocker arm at the rocker shaft location and a sintered alloy chip casting is used at the frictional surface of the cam. The valve side of the rocker arm is provided with a hydraulic lash adjuster to maintain a "zero" valve clearance, as well as to provide quiet operation and eliminate valve clearance adjustment. The rocker arm on the exhaust valve side has a "Y"-letter design and operates two exhaust valves. The rocker shaft has an oil passage in it. One side of shaft end is provided with a built-in relief valve.

5. Valve Rocker ASSY



B2-984

Fig. 4

6. Hydraulic Lash Adjuster

The hydraulic lash adjuster is built into each rocker arm on the valve side. A total of sixteen lash adjusters are employed.

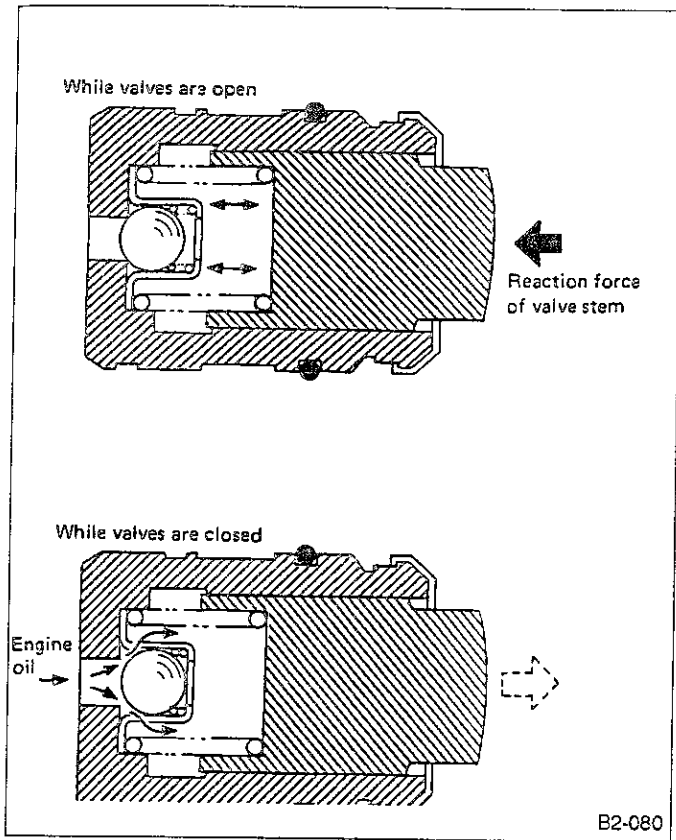


Fig. 5

7. Camshaft

The cam nose part is finished with "chill" treatment to increase wear resistance and anti-scuffing property. The right-hand camshaft is supported by three journals inside the cylinder head while the left-hand camshaft is supported by four journals. The flanges of these camshafts are also supported by the camshaft support ends to receive thrust force.

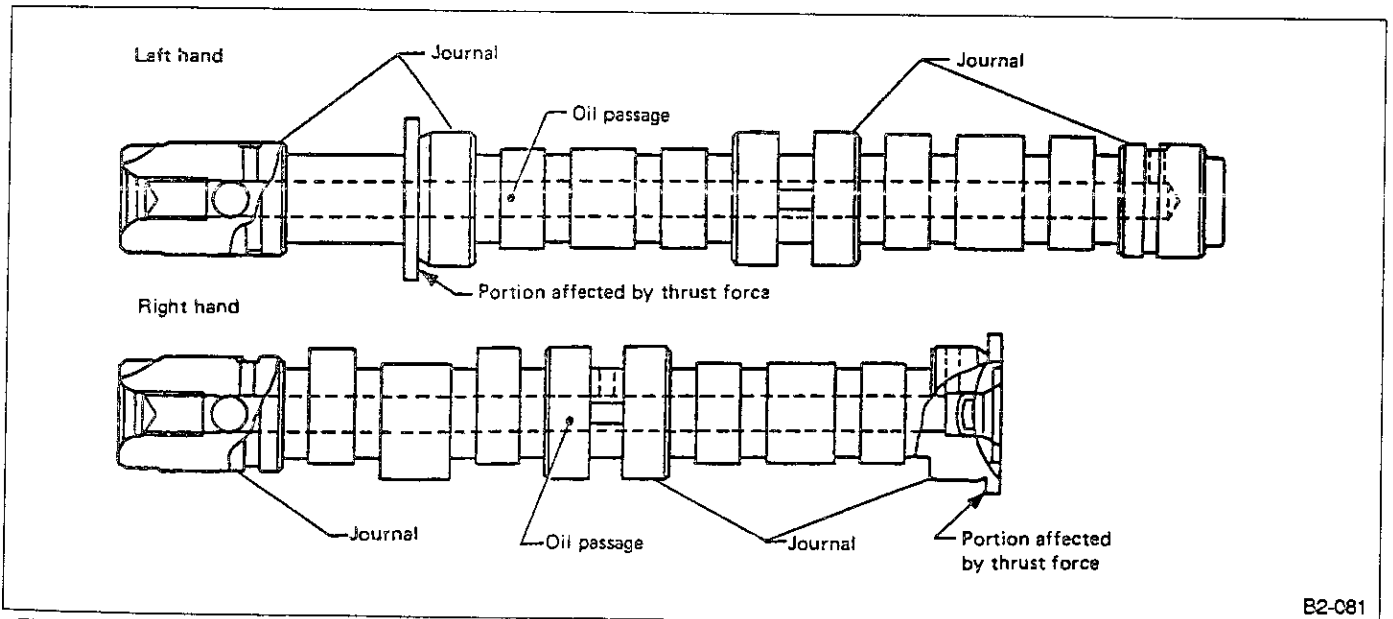


Fig. 6

8. Cylinder Head

Combustion chambers in the cylinder head are compact, center plug, pentroof types which feature a wide "squish" area for increased combustion efficiency.

Four valves (two intake and two exhaust), which are arranged in a cross-flow design, are used per cylinder.

The cylinder head gasket is made from carbon material (not asbestos). Its core is metal provided with metal hooks to increase resistance to both heat and wear.

The inner side of grommets used in the cylinder bore are reinforced with wire to withstand both high combustion pressure and temperature.

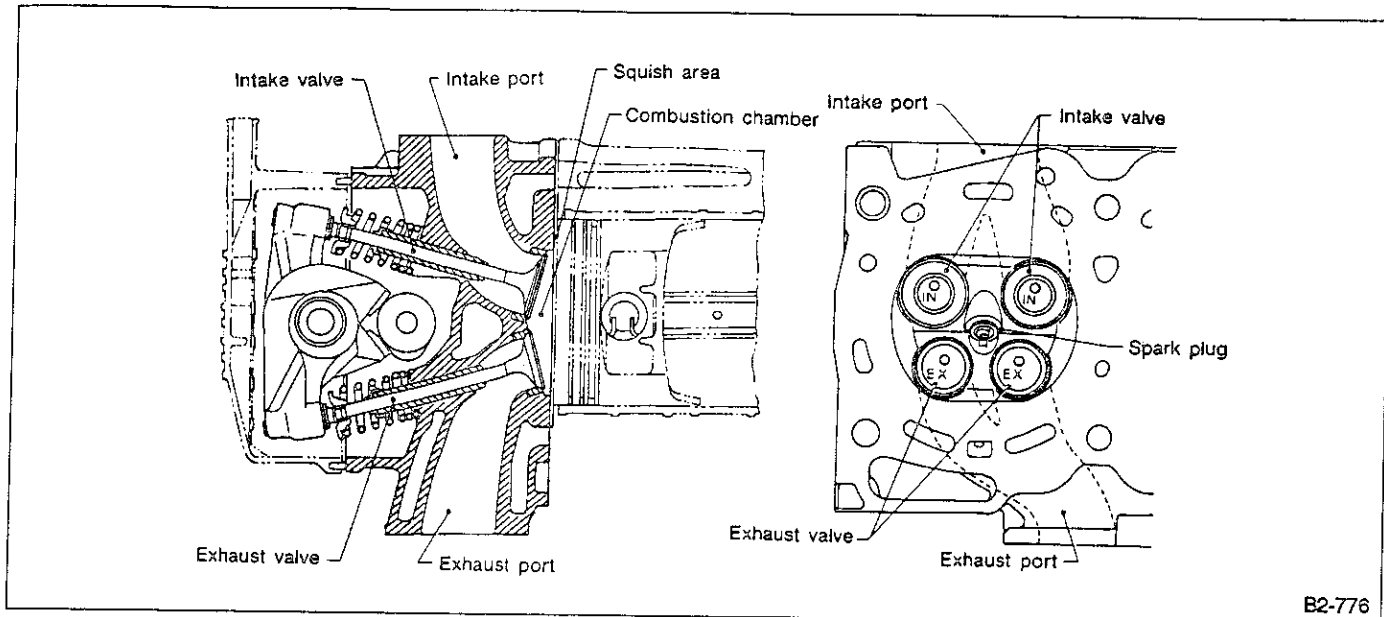


Fig. 7

9. Cylinder Block

The cylinder block is made from aluminum diecasting. The cylinder perimeter has an open-deck design which is lightweight, highly rigid and has superb cooling efficiency.

The cylinder liners are made from cast iron and are dry types which are totally cast with aluminum cylinder block. Five main journal block designs are employed to increase stiffness and quiet operation. The oil pump is located in the front center of the cylinder block and the

water pump is located at the front of the left-cylinder bank. At the rear of the right-cylinder block is a separator which eliminates oil mist contained in the blow-by gas.

10. Crankshaft

The crankshaft is supported by five bearings to provide high rigidity and strength. The corners of the crankshaft journals and webs, as well as the crank pins and webs,

are finished with fillet-roll work to increase stiffness. The five crankshaft bearings are made from aluminum alloy and the No. 3 bearing is provided with a flanged metal to receive thrust force.

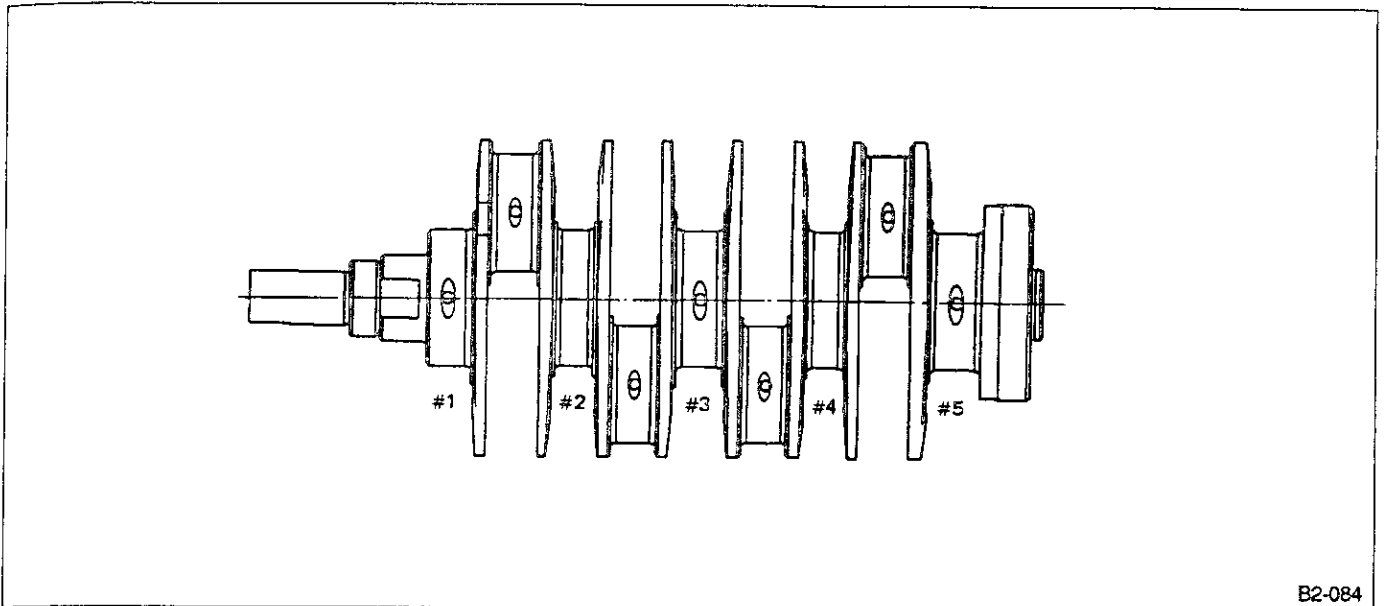


Fig. 8

B2-084

11. Piston

The piston skirt has a "slipper" design to reduce weight and sliding. The oil control ring groove utilizes a slit design.

The piston pin is located in an offset position. The Nos. 1 and 3 pistons are offset in the lower direction while the Nos. 2 and 4 pistons are offset in the upper direction.

The piston head is recessed for both the intake and exhaust valves. It also has symbols used to identify the location and the direction of installation.

Three piston rings are used for each piston—two compression rings and one oil ring. The top piston ring has an inner-bevel design and the second piston ring has an interrupt design to reduce oil consumption.

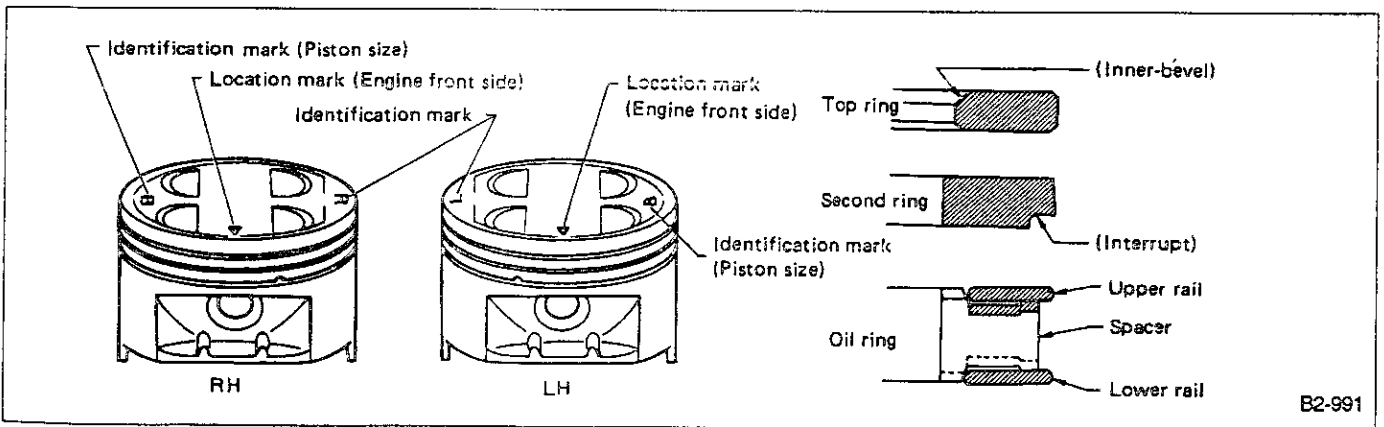


Fig. 9

B2-991

S SPECIFICATIONS AND SERVICE DATA

A: SPECIFICATIONS

		2200cc	2000cc	1800cc		1600cc	
		MPFI	MPFI	SPFI	Carburetor	Carburetor	
ENGINE	Type	Horizontally opposed, liquid cooled, 4-cylinder, 4-stroke gasoline engine					
	Valve arrangement	Belt driven, single over-head camshaft, 4-valve/cylinder					
	Bore x Stroke	mm (in)	96.9 x 75 (3.815 x 2.95)	92 x 75 (3.62 x 2.95)	87.9 x 75 (3.461 x 2.95)		87.9 x 65.8 (3.461 x 2.591)
	Piston displacement	m ³ (cu in)	2,212 (134.98)	1,994 (121.67)	1,820 (111.06)		1,597 (97.45)
	Compression ratio		9.5	9.5	9.7		8.9
	Compression pressure (at 200 - 300 rpm)	kPa (kg/cm ² , psi)	1,079 — 1,275 (11.0 — 13.0, 156 — 185)	1,079 — 1,275 (11.0 — 13.0, 156 — 185)	883 — 1,177 (9.0 — 12.0, 128 — 171)		88.3 — 1,079 (9.0 — 11.0, 128 — 156)
	Number of piston rings		Pressure ring: 2, Oil ring: 1				
	Intake valve timing	Opening	2° BTDC	4° BTDC	12° BTDC		9° BTDC
		Closing	60° ABDC	52° ABDC	58° ABDC		51° ABDC
	Exhaust valve timing	Opening	50° BBDC	48° BBDC	58° BBDC		54° BBDC
		Closing	16° ATDC	12° ATDC	12° ATDC		6° ATDC
	Idling speed (At neutral (on N) position) rpm		800 ± 100 (No load)	800 ± 100 (No load)	MT: 850 ± 100 (No load) AT: 800 ± 100 (No load)	800 ± 50 (No load, with vacuum advancer)	900 ± 50 (No load, with vacuum advancer)
	Firing order		1 → 3 → 2 → 4				
	Ignition timing	BTDC/rpm	23° ± 10°/800	23° ± 10°/800	MT: 20° ± 10°/ 850 AT: 20° ± 10°/800	20° ± 5°/800 (with vacuum advancer)	20° ± 5°/900 (with vacuum advancer)

B: SERVICE DATA

Belt tension adjuster	Protrusion of adjuster rod		15.4 — 16.4 mm	(0.606 — 0.646 in)		
Belt tensioner	Spacer OD		16 mm	(0.63 in)		
	Tensioner bushing ID		16.16 mm	(0.6362 in)		
	Clearance between spacer and bushing		STD	0.117 — 0.180 mm (0.0046 — 0.0071 in)		
			Limit	0.230 mm (0.0091 in)		
	Side clearance of spacer		STD	0.37 — 0.54 mm (0.0146 — 0.0213 in)		
Limit			0.8 mm (0.031 in)			
Valve rocker arm	Clearance between shaft and arm		STD	0.020 — 0.081 mm (0.0008 — 0.0032 in)		
			Limit	0.10 mm (0.0039 in)		
Camshaft	Bend limit		0.025 mm	(0.0010 in)		
	Thrust clearance		STD	0.030 — 0.260 mm (0.0012 — 0.0102 in)		
			Limit	0.35 mm (0.0138 in)		
	Cam lobe height		2200cc	STD	32.390 — 32.490 mm (1.2752 — 1.2791 in)	
				Wear limit	0.3 mm (0.012 in)	
			2000cc	STD	32.364 — 32.464 mm (1.2742 — 1.2781 in)	
				Wear limit	0.3 mm (0.012 in)	
	1800cc 1600cc		STD	32.495 — 32.595 mm (1.2793 — 1.2833 in)		
			Wear limit	0.3 mm (0.012 in)		
	Camshaft journal OD	RH	Front	LH	Rear	31.935 — 31.950 mm (1.2573 — 1.2579 in)
			Center		Center	37.435 — 37.450 mm (1.4738 — 1.4744 in)
			Rear		Front	37.935 — 37.950 mm (1.4935 — 1.4941 in)
	Camshaft journal hole ID	RH	Front	LH	Rear	32.005 — 32.025 mm (1.2600 — 1.2608 in)
			Center		Center	37.505 — 37.525 mm (1.4766 — 1.4774 in)
Rear			Front		38.005 — 38.025 mm (1.4963 — 1.4970 in)	
Oil clearance		STD	0.055 — 0.090 mm (0.0022 — 0.0035 in)			
		Limit	0.10 mm (0.0039 in)			
Cylinder head	Surface warpage limit		0.05 mm	(0.0020 in)		
	Surface grinding limit		0.1 mm	(0.004 in)		
	Standard height		98.3 mm	(3.870 in)		
Valve set	Refacing angle		90°			
	Contacting width		Intake	STD	0.7 mm (0.028 in)	
				Limit	1.4 mm (0.055 in)	
			Exhaust	STD	1.0 mm (0.039 in)	
				Limit	1.8 mm (0.071 in)	
Valve guide	Inner diameter		6.000 — 6.012 mm	(0.2362 — 0.2367 in)		
	Protrusion above head		17.5 — 18.0 mm	(0.689 — 0.709 in)		
Valve	Head edge thickness		Intake	STD	1.0 mm (0.039 in)	
				Limit	0.8 mm (0.031 in)	
			Exhaust	STD	1.2 mm (0.047 in)	
				Limit	0.8 mm (0.031 in)	
	Stem diameter		Intake	5.950 — 5.965 mm (0.2343 — 0.2348 in)		
			Exhaust	5.945 — 5.960 mm (0.2341 — 0.2346 in)		
	Stem oil clearance		STD	Intake	0.035 — 0.062 mm (0.0014 — 0.0024 in)	
				Exhaust	0.040 — 0.067 mm (0.0016 — 0.0026 in)	
		Limit	-	0.15 mm (0.0059 in)		
Overall length		Intake	101.0 mm	(3.976 in)		
		Exhaust	101.2 mm	(3.984 in)		

STD: Standard ID: Inner diameter OD: Outer diameter

Valve spring	Free length		46.16 mm	(1.8173 in)		
	Squariness		2.5°, 1.9 mm	(0.075 in)		
	Tension/spring height		190.3 — 219.7 N (19.4 — 22.4 kg, 42.8 — 49.4 lb)/37.0 mm (1.457 in) 401.1 — 461.9 N (40.9 — 47.1 kg, 90.2 — 103.9 lb)/ 29.2 mm (1.150 in)			
Cylinder block	Surface warpage limit (mating with cylinder head)		0.05 mm	(0.0020 in)		
	Surface grinding limit		0.1 mm	(0.004 in)		
	Cylinder bore	2200cc	A	96.905 — 96.915 mm	(3.8151 — 3.8155 in)	
			B	96.895 — 96.905 mm	(3.8148 — 3.8151 in)	
			C	96.885 — 96.895 mm	(3.8144 — 3.8148 in)	
		2000cc	A	92.005 — 92.015 mm	(3.6222 — 3.6226 in)	
			B	91.995 — 92.005 mm	(3.6218 — 3.6222 in)	
			C	91.985 — 91.995 mm	(3.6214 — 3.6218 in)	
		1800cc 1600cc	A	87.905 — 87.915 mm	(3.4608 — 3.4612 in)	
			B	87.895 — 87.905 mm	(3.4604 — 3.4608 in)	
			C	87.885 — 87.895 mm	(3.4600 — 3.4604 in)	
	Taper		STD	0.015 mm	(0.0006 in)	
			Limit	0.050 mm	(0.0020 in)	
Out-of-roundness		STD	0.010 mm	(0.0004 in)		
		Limit	0.050 mm	(0.0020 in)		
Piston clearance		STD	0.010 — 0.030 mm	(0.0004 — 0.0012 in)		
		Limit	0.060 mm	(0.0024 in)		
Enlarging (boring) limit			0.5 mm	(0.020 in)		
Piston	Outer diameter	2200cc	STD	A	96.885 — 96.895 mm	(3.8144 — 3.8148 in)
				B	96.875 — 96.885 mm	(3.8140 — 3.8144 in)
				C	96.865 — 96.875 mm	(3.8136 — 3.8140 in)
			0.25 mm (0.0098 in) OS		97.125 — 97.135 mm	(3.8238 — 3.8242 in)
			0.50 mm (0.0197 in) OS		97.375 — 97.385 mm	(3.8337 — 3.8340 in)
			2000cc	STD	A	91.985 — 91.995 mm
		B			91.975 — 91.985 mm	(3.6211 — 3.6214 in)
		C			91.965 — 91.975 mm	(3.6207 — 3.6211 in)
		0.25 mm (0.0098 in) OS		92.225 — 92.235 mm	(3.6309 — 3.6313 in)	
		0.50 mm (0.0197 in) OS		92.475 — 92.485 mm	(3.6407 — 3.6411 in)	
		1800cc 1600cc		STD	A	87.885 — 87.895 mm
			B		87.875 — 87.885 mm	(3.4596 — 3.4600 in)
			C		87.865 — 87.875 mm	(3.4592 — 3.4596 in)
			0.25 mm (0.0098 in) OS		88.125 — 88.135 mm	(3.4695 — 3.4699 in)
			0.50 mm (0.0197 in) OS		88.375 — 88.385 mm	(3.4793 — 3.4797 in)
Standard inner diameter of piston pin hole				23.000 — 23.006 mm	(0.9055 — 0.9057 in)	
Piston pin	Outer diameter		22.994 — 23.000 mm	(0.9053 — 0.9055 in)		
	Standard clearance between piston pin and hole in piston		0.001 — 0.013 mm	(0.00004 — 0.00051 in)		
	Degree of fit		Piston pin must be fitted into position with thumb at 20°C (68°F).			
Piston ring	Piston ring gap	Top ring	STD	0.20 — 0.35 mm	(0.0079 — 0.0138 in)	
			Limit	1.0 mm	(0.039 in)	
		Second ring	STD	0.20 — 0.35 mm	(0.0079 — 0.0138 in)	
			Limit	1.0 mm	(0.039 in)	
		Oil ring	STD	0.20 — 0.70 mm	(0.0079 — 0.0276 in)	
			Limit	1.5 mm	(0.059 in)	
	Clearance between piston ring and piston ring groove	Top ring	STD	0.040 — 0.080 mm	(0.0016 — 0.0031 in)	
			Limit	0.15 mm	(0.0059 in)	
	Second ring	STD	0.030 — 0.070 mm	(0.0012 — 0.0028 in)		
		Limit	0.15 mm	(0.0059 in)		
Connecting rod	Bend twist per 100 mm (3.94 in) in length		Limit	0.10 mm	(0.0039 in)	
	Side clearance		STD	0.070 — 0.330 mm	(0.0028 — 0.0130 in)	
			Limit	0.4 mm	(0.016 in)	

STD: Standard OS: Oversize

ENGINE (SOHC)

[SOB0] 2-3a

Connecting rod bearing	Oil clearance		STD	0.015 — 0.045 mm	(0.0006 — 0.0018 in)
			Limit	0.05 mm	(0.0020 in)
	Thickness at center portion	STD		1.492 — 1.501 mm	(0.0587 — 0.0591 in)
		0.03 mm (0.0012 in) US		1.510 — 1.513 mm	(0.0594 — 0.0596 in)
		0.05 mm (0.0020 in) US		1.520 — 1.523 mm	(0.0598 — 0.0600 in)
0.25 mm (0.0098 in) US		1.620 — 1.623 mm	(0.0638 — 0.0639 in)		
Connecting rod bushing	Clearance between piston pin and bushing		STD	0 — 0.022 mm	(0 — 0.0009 in)
			Limit	0.030 mm	(0.0012 in)
Crankshaft	Bend limit			0.035 mm	(0.0014 in)
	Crankpin and crank journal	Out-of-roundness		0.030 mm (0.0012 in) or less	
		Grinding limit		0.250 mm	(0.0098 in)
	Crankpin outer diameter	STD		51.984 — 52.000 mm	(2.0466 — 2.0472 in)
		0.03 mm (0.0012 in) US		51.954 — 51.970 mm	(2.0454 — 2.0461 in)
		0.05 mm (0.0020 in) US		51.934 — 51.950 mm	(2.0446 — 2.0453 in)
		0.25 mm (0.0098 in) US		51.734 — 51.750 mm	(2.0368 — 2.0374 in)
	Crank journal outer diameter	STD		59.984 — 60.000 mm	(2.3616 — 2.3622 in)
		0.03 mm (0.0012 in) US		59.954 — 59.970 mm	(2.3604 — 2.3610 in)
		0.05 mm (0.0020 in) US		59.934 — 59.950 mm	(2.3596 — 2.3602 in)
		0.25 mm (0.0098 in) US		59.734 — 59.750 mm	(2.3517 — 2.3524 in)
	Thrust clearance	STD		0.030 — 0.115 mm	(0.0012 — 0.0045 in)
		Limit		0.25 mm	(0.0098 in)
	Oil clearance	#1, #5	STD	0.010 — 0.030 mm	(0.0004 — 0.0012 in)
			Limit	0.040 mm	(0.0016 in)
#2, #3, #4		STD	0.010 — 0.030 mm	(0.0004 — 0.0012 in)	
		Limit	0.035 mm	(0.0014 in)	
Crankshaft bearing	Crankshaft bearing thickness	#1, #5	STD	1.998 — 2.011 mm	(0.0787 — 0.0792 in)
			0.03 mm (0.0012 in) US	2.017 — 2.020 mm	(0.0794 — 0.0795 in)
			0.05 mm (0.0020 in) US	2.027 — 2.030 mm	(0.0798 — 0.0799 in)
			0.25 mm (0.0098 in) US	2.127 — 2.130 mm	(0.0837 — 0.0839 in)
		#2, #3, #4	STD	2.000 — 2.013 mm	(0.0787 — 0.0793 in)
			0.03 mm (0.0012 in) US	2.019 — 2.022 mm	(0.0795 — 0.0796 in)
			0.05 mm (0.0020 in) US	2.029 — 2.032 mm	(0.0799 — 0.0800 in)
			0.25 mm (0.0098 in) US	2.129 — 2.132 mm	(0.0838 — 0.0839 in)

STD: Standard US: Under size

C COMPONENT PARTS

1. Timing Belt

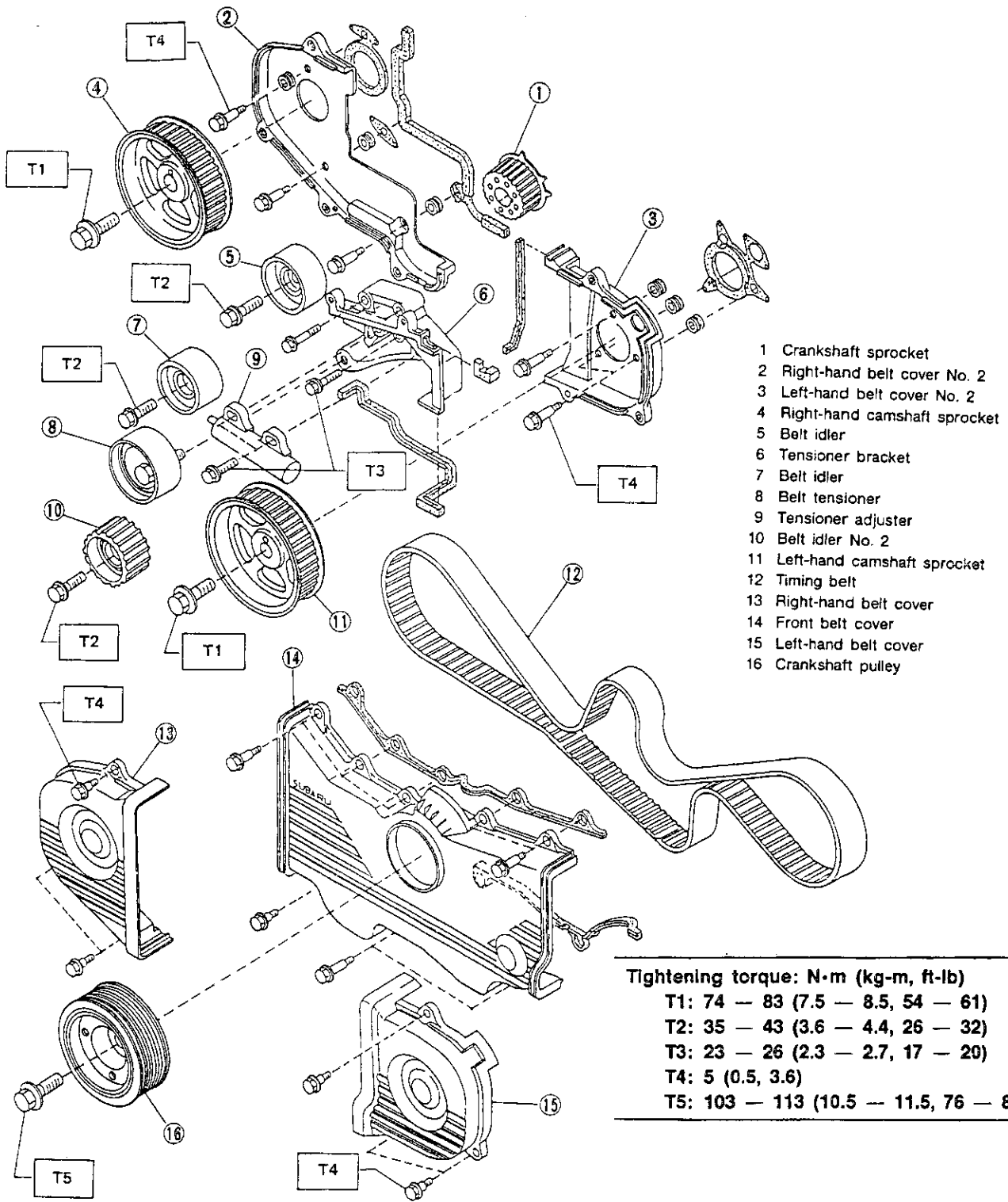


Fig. 10

2. Cylinder Head and Camshaft

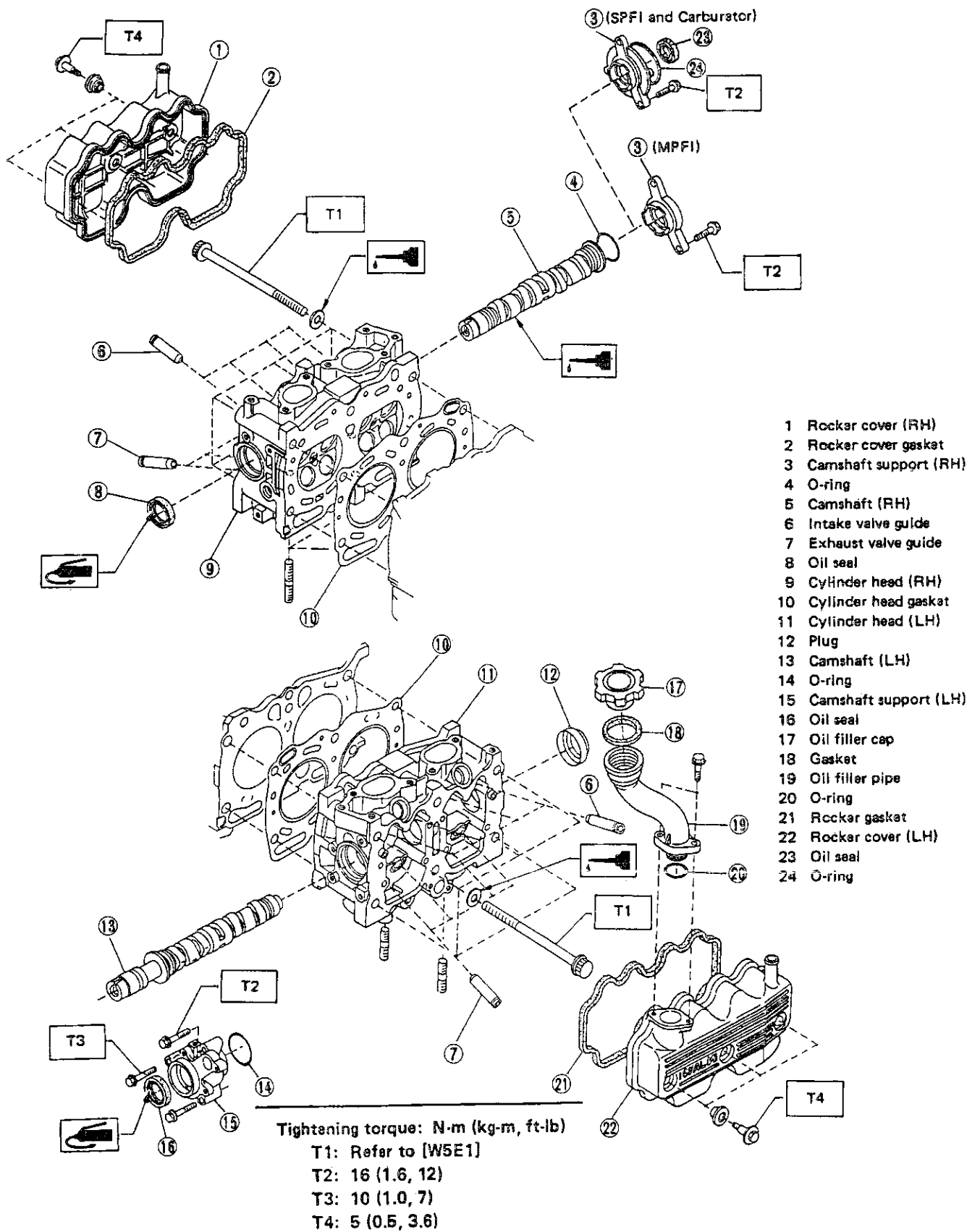
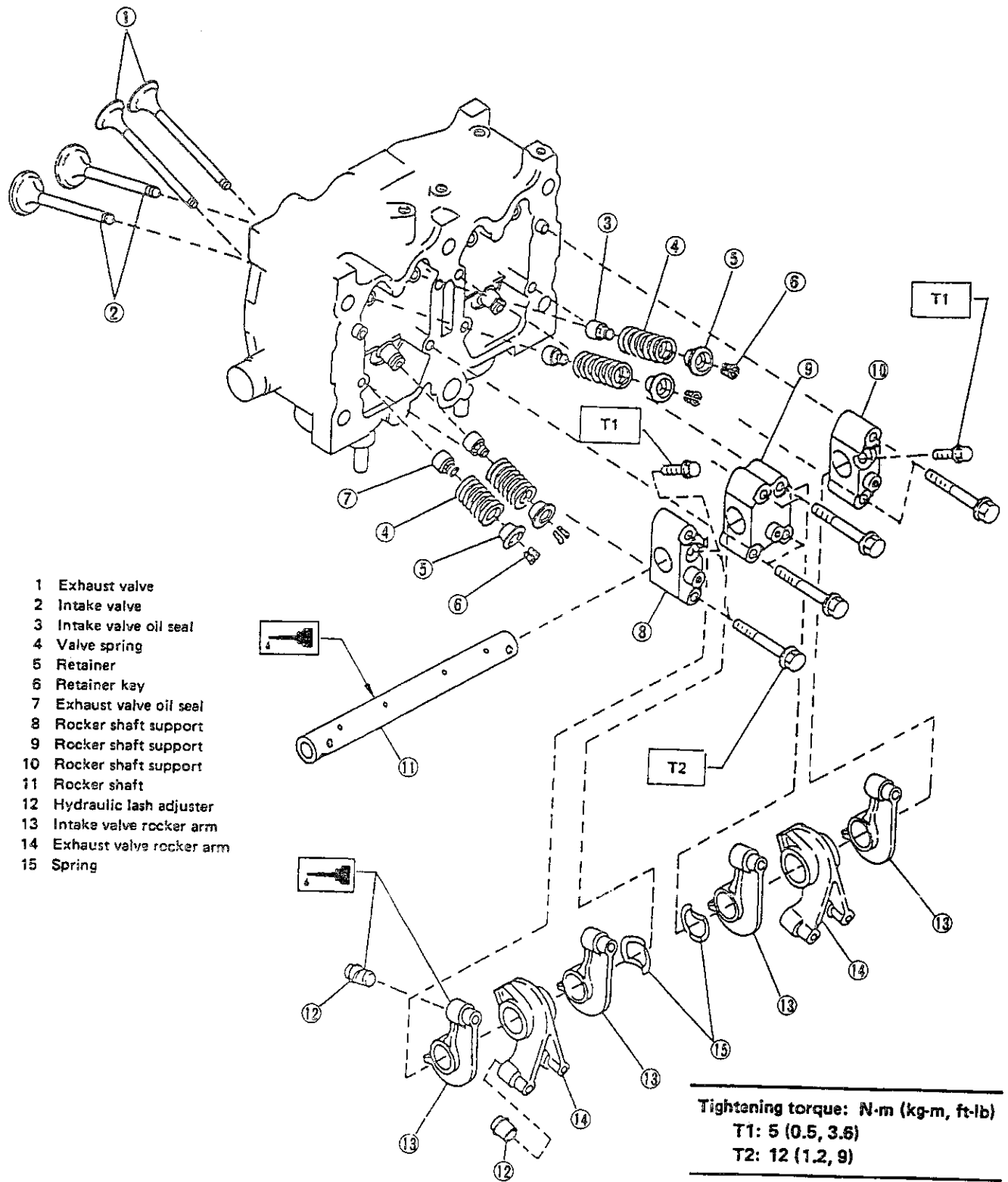


Fig. 11

3. Cylinder Head and Valve ASSY



- 1 Exhaust valve
- 2 Intake valve
- 3 Intake valve oil seal
- 4 Valve spring
- 5 Retainer
- 6 Retainer key
- 7 Exhaust valve oil seal
- 8 Rocker shaft support
- 9 Rocker shaft support
- 10 Rocker shaft support
- 11 Rocker shaft
- 12 Hydraulic lash adjuster
- 13 Intake valve rocker arm
- 14 Exhaust valve rocker arm
- 15 Spring

Tightening torque: N-m (kg-m, ft-lb)
 T1: 5 (0.5, 3.6)
 T2: 12 (1.2, 9)

Fig. 12

4. Cylinder Block

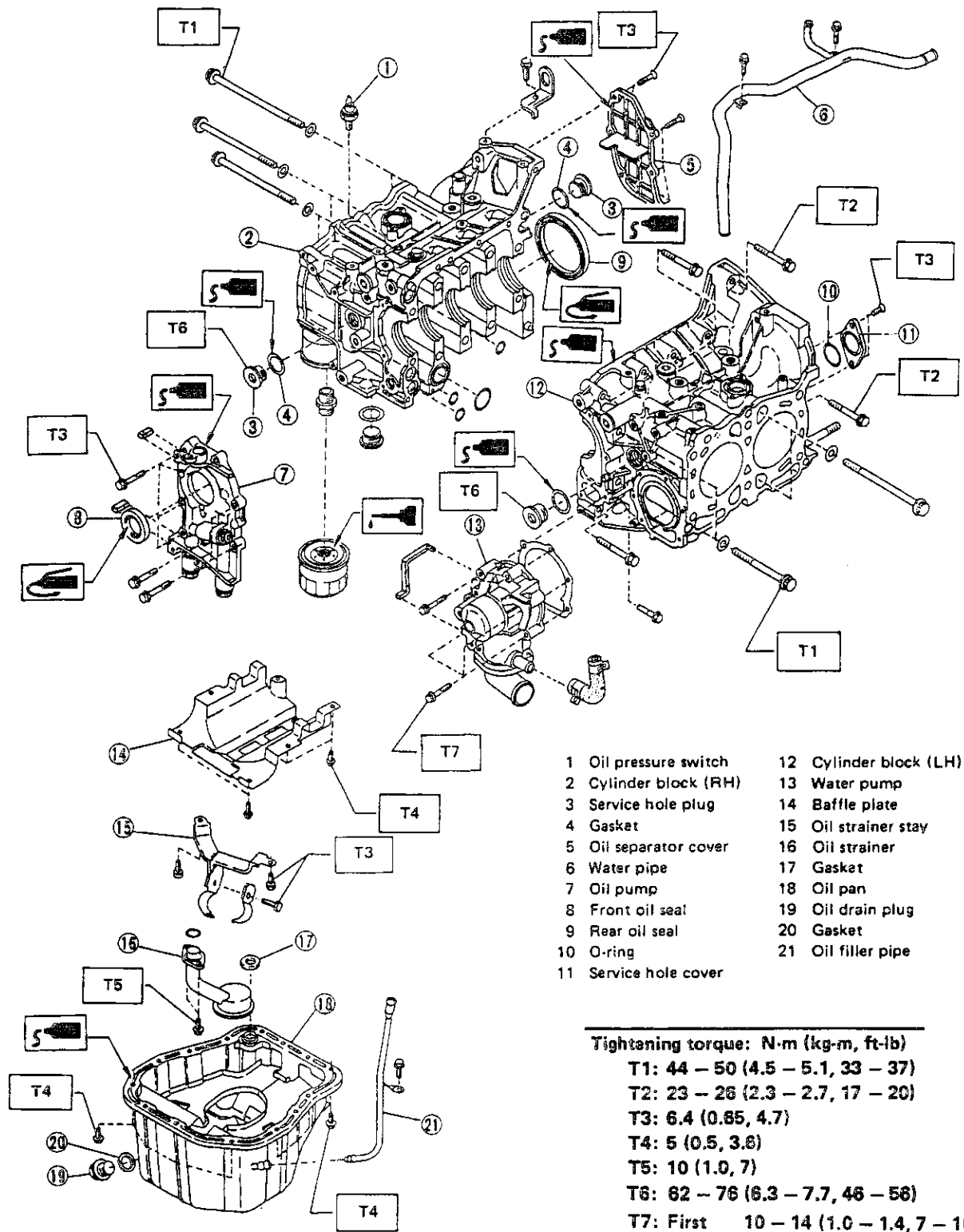
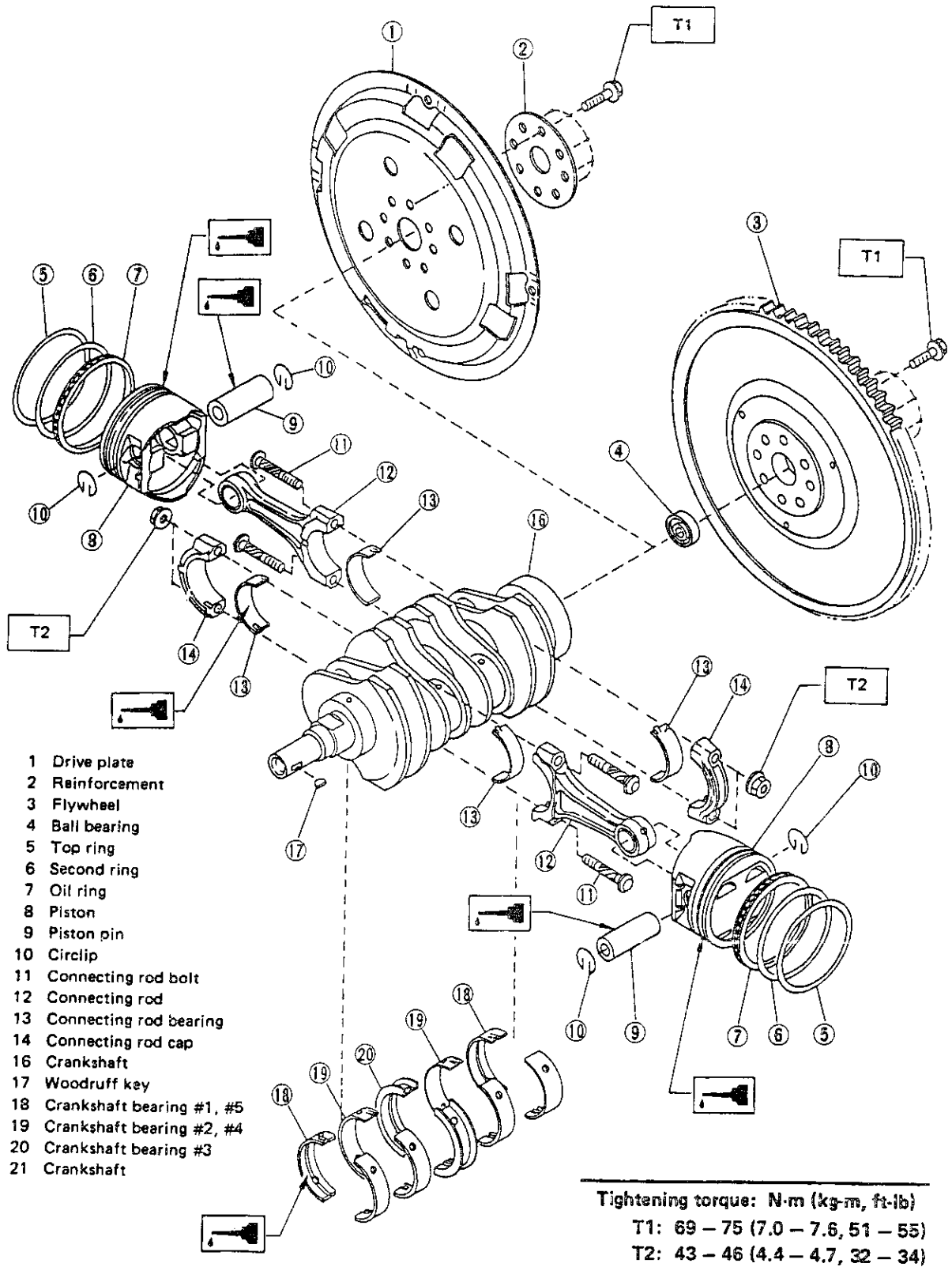


Fig. 13

5. Crankshaft and Piston



- 1 Drive plate
- 2 Reinforcement
- 3 Flywheel
- 4 Ball bearing
- 5 Top ring
- 6 Second ring
- 7 Oil ring
- 8 Piston
- 9 Piston pin
- 10 Circlip
- 11 Connecting rod bolt
- 12 Connecting rod
- 13 Connecting rod bearing
- 14 Connecting rod cap
- 16 Crankshaft
- 17 Woodruff key
- 18 Crankshaft bearing #1, #5
- 19 Crankshaft bearing #2, #4
- 20 Crankshaft bearing #3
- 21 Crankshaft

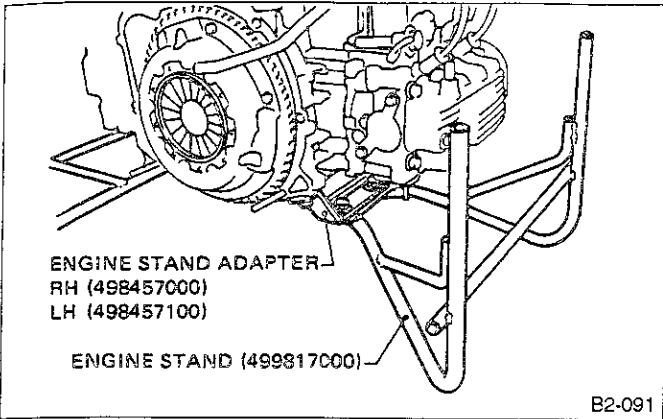
Tightening torque: N·m (kg·m, ft·lb)	
T1:	69 – 75 (7.0 – 7.6, 51 – 55)
T2:	43 – 46 (4.4 – 4.7, 32 – 34)

Fig. 14

W SERVICE PROCEDURE

1. General Precautions

1) Before disassembling engine, install on ENGINE STAND.



B2-091

Fig. 15

2) All parts should be thoroughly cleaned, paying special attention to the engine oil passages, pistons and bearings.

3) Rotating parts and sliding parts such as piston, bearing and gear should be coated with oil prior to assembly.

4) Be careful not to let oil, grease or coolant contact the timing belt, clutch disc and flywheel.

5) All removed parts, if to be reused, should be reinstalled in the original positions and directions.

6) Gaskets and lock washers must be replaced with new ones. Liquid gasket should be used where specified to prevent leakage.

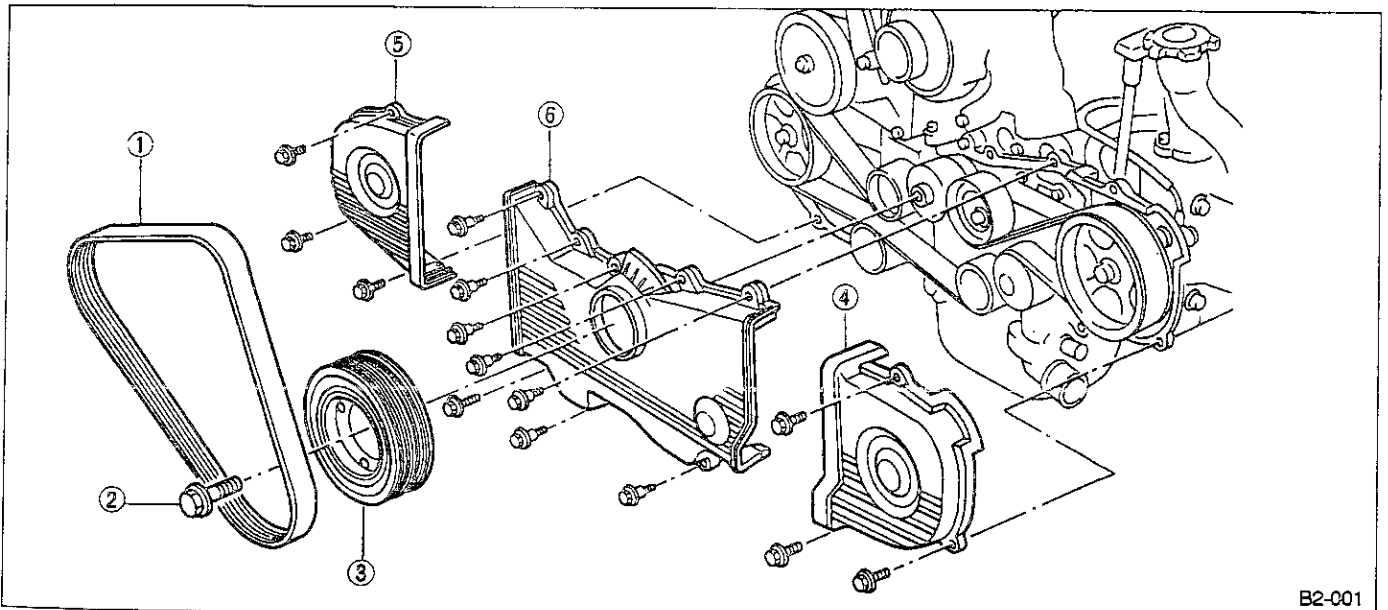
7) Bolts, nuts and washers should be replaced with new ones as required.

8) Even if necessary inspections have been made in advance, proceed with assembly work while making rechecks.

2. Timing Belt

A: REMOVAL

1. CRANKSHAFT PULLEY AND BELT COVER

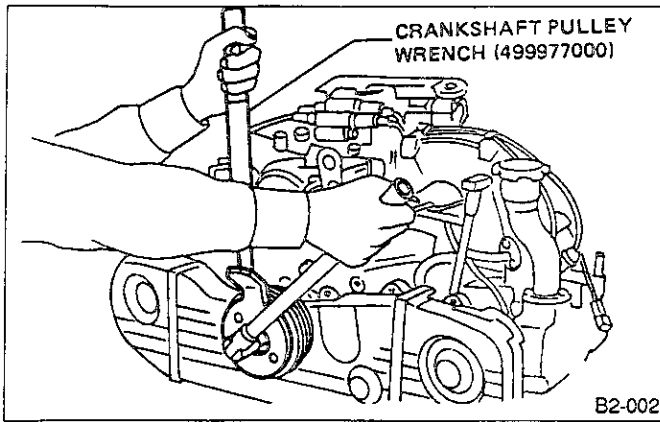


B2-001

Fig. 16

1) Remove V-belt.

2) Remove pulley bolt. To lock crankshaft, use Special Tool.



- 3) Remove crankshaft pulley.
- 4) Remove left-hand belt cover.
- 5) Remove right-hand belt cover.
- 6) Remove front belt cover.

Fig. 17

2. TIMING BELT

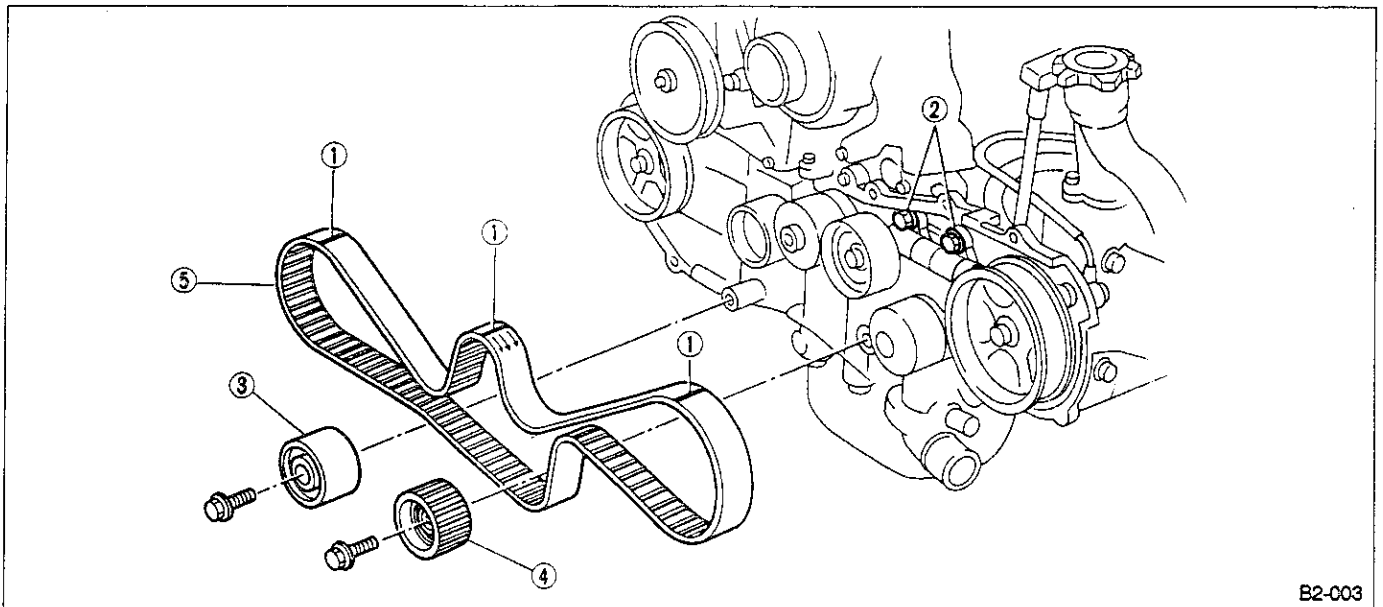


Fig. 18

1) If alignment mark and/or arrow mark (which indicates rotation direction) on timing belt fade away, put new marks before removing timing belt as follows:

- (1) Turn crankshaft, and align alignment marks on crankshaft sprocket, and left and right camshaft sprockets with notches of belt cover and cylinder block.

Special tool: CRANKSHAFT SOCKET (499987500)

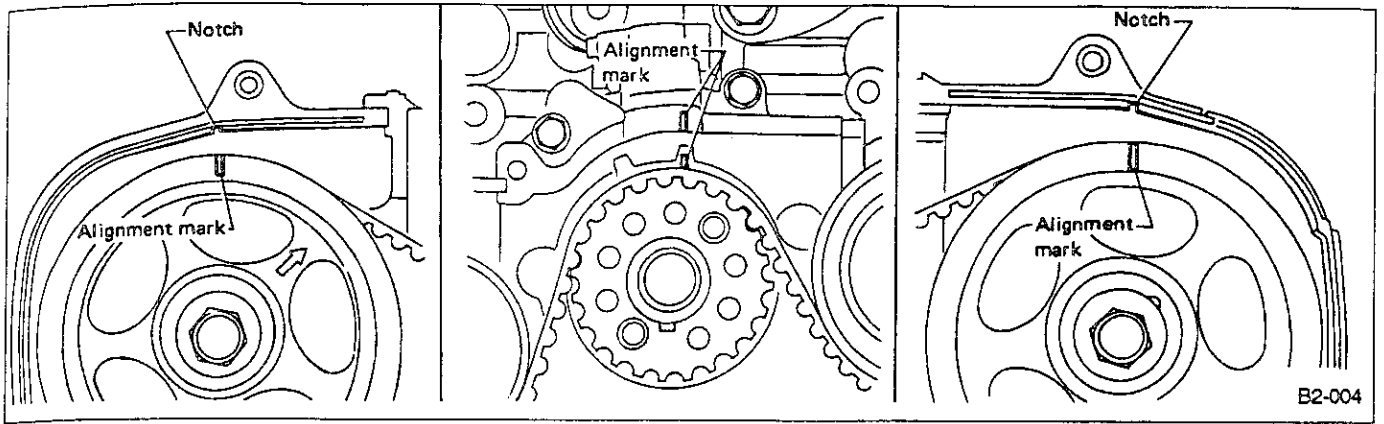


Fig. 19

(2) Using white paint, put alignment and/or arrow marks on timing belts in relation to the sprockets.

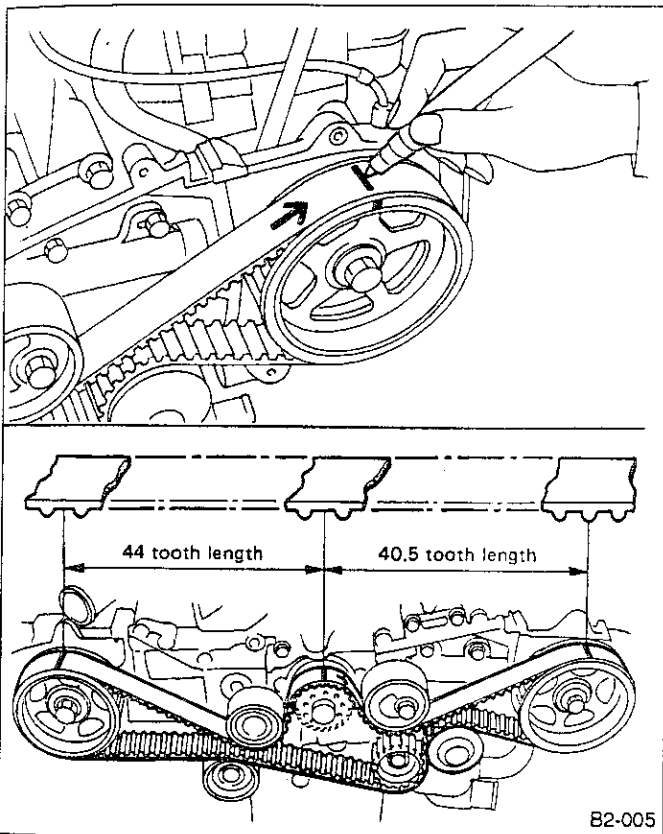
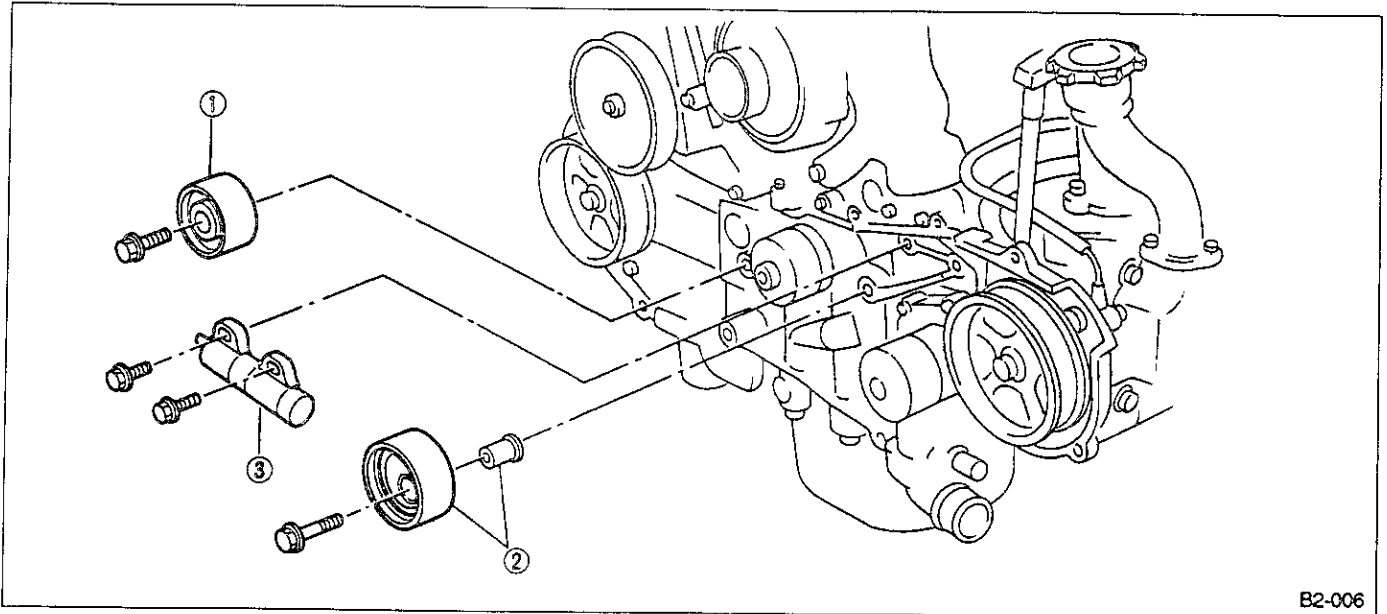


Fig. 20

- 2) Loosen tensioner adjuster mounting bolts.
- 3) Remove belt idler.

- 4) Remove belt idler No. 2
- 5) Remove timing belt.

3. BELT TENSIONER AND IDLER



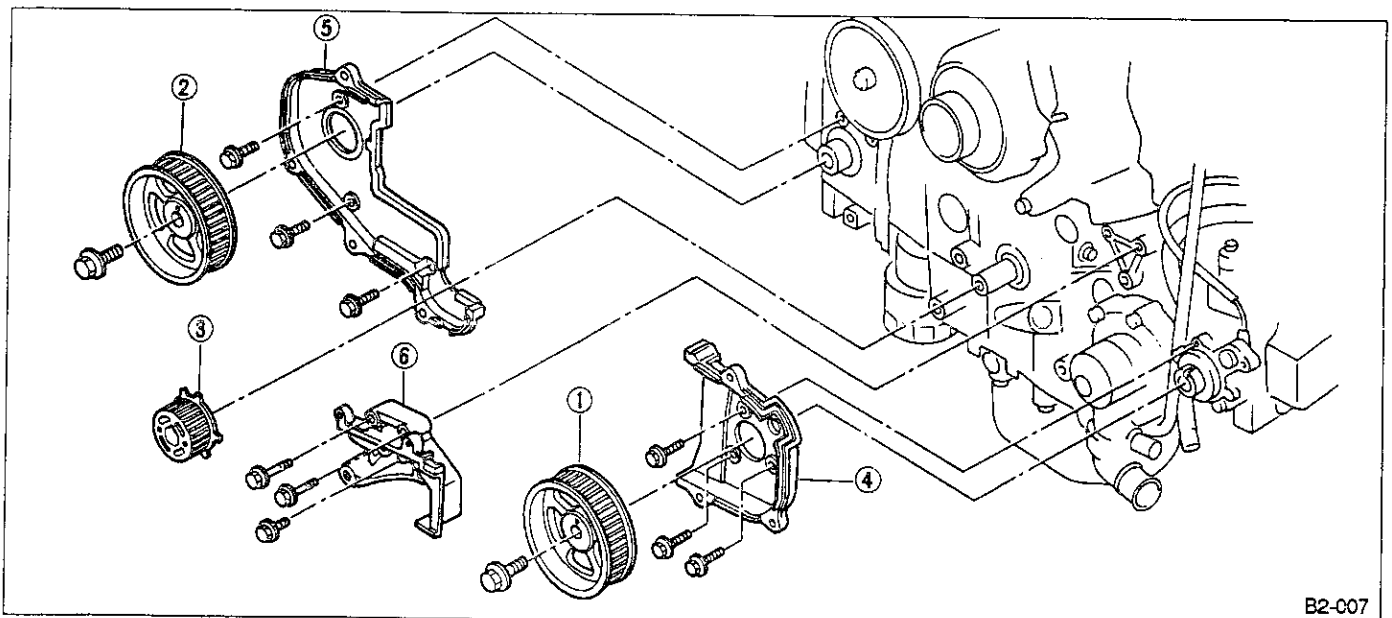
B2-006

Fig. 21

- 1) Remove belt idler.
- 2) Remove belt tensioner and spacer.

- 3) Remove belt tension adjuster.

4. SPROCKET



B2-007

Fig. 22

- 1) Remove left-hand camshaft sprocket.

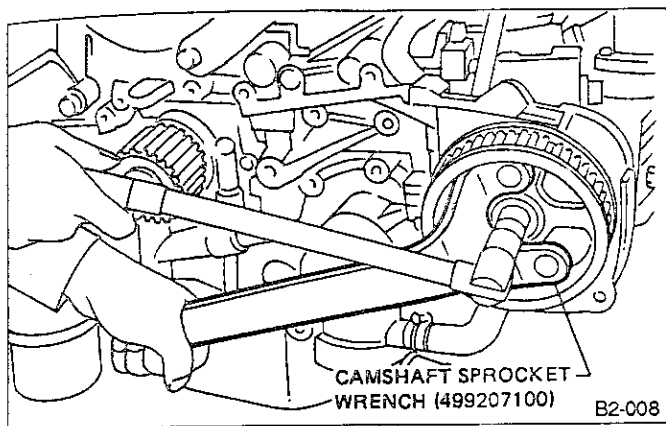


Fig. 23

- 2) Remove right-hand camshaft sprocket. To lock camshaft, use CAMSHAFT SPROCKET WRENCH.
- 3) Remove crankshaft sprocket.
- 4) Remove left-hand belt cover No. 2.
- 5) Remove right-hand belt cover No. 2.
- 6) Remove tensioner bracket.

B: INSPECTION

1. TIMING BELT

- 1) Check timing belt teeth for breaks, cracks, and wear. If any fault is found, replace belt.
- 2) Check the condition of back side of belt; if any crack is found, replace belt.
 - a. Be careful not to let oil, grease or coolant contact the belt. Remove quickly and thoroughly if this happens.
 - b. Do not bend the belt sharply. [The bending radius must be greater than 60 mm (2.36 in).]

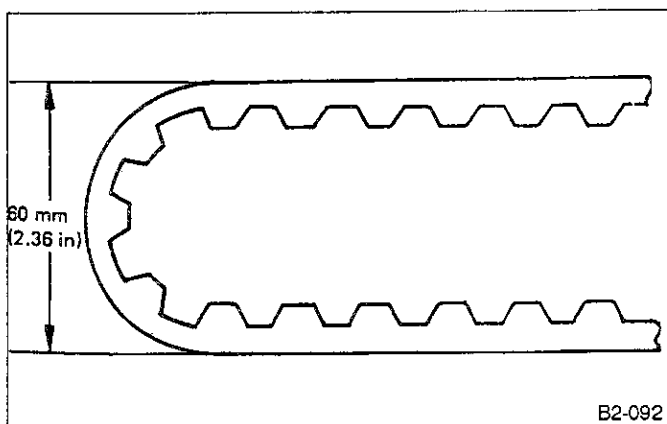


Fig. 24

2. BELT TENSION ADJUSTER

- 1) Visually check oil seals for leaks, and rod ends for abnormal wear or scratches. If necessary, replace faulty parts.

Slight traces of oil at rod' oil seal does not indicate a problem.

- 2) While holding tensioner with both hands, push the rod section against floor or wall with a force of 147 to 490 N (15 to 50 kg, 33 to 110 lb) to ensure that the rod section does not move. If it moves, replace tension adjuster with a new one.
- 3) Measure the extension of rod beyond the body. If it is not within specifications, replace with a new one.

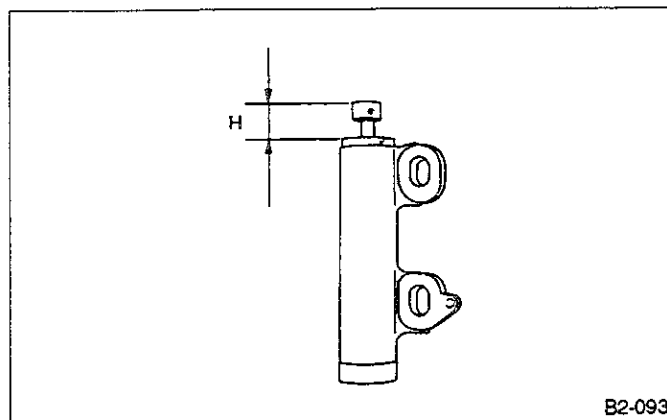


Fig. 25

Rod extension H:

15.4 — 16.4 mm (0.606 — 0.646 in)

3. BELT TENSIONER

- 1) Check mating surfaces of timing belt and contact point of tension adjuster rod for abnormal wear or scratches. Replace belt tensioner if faulty.
- 2) Check spacer and tensioner bushing for wear.

4. BELT IDLER

Check idler for smooth rotation. Replace if noise or excessive play is noted.

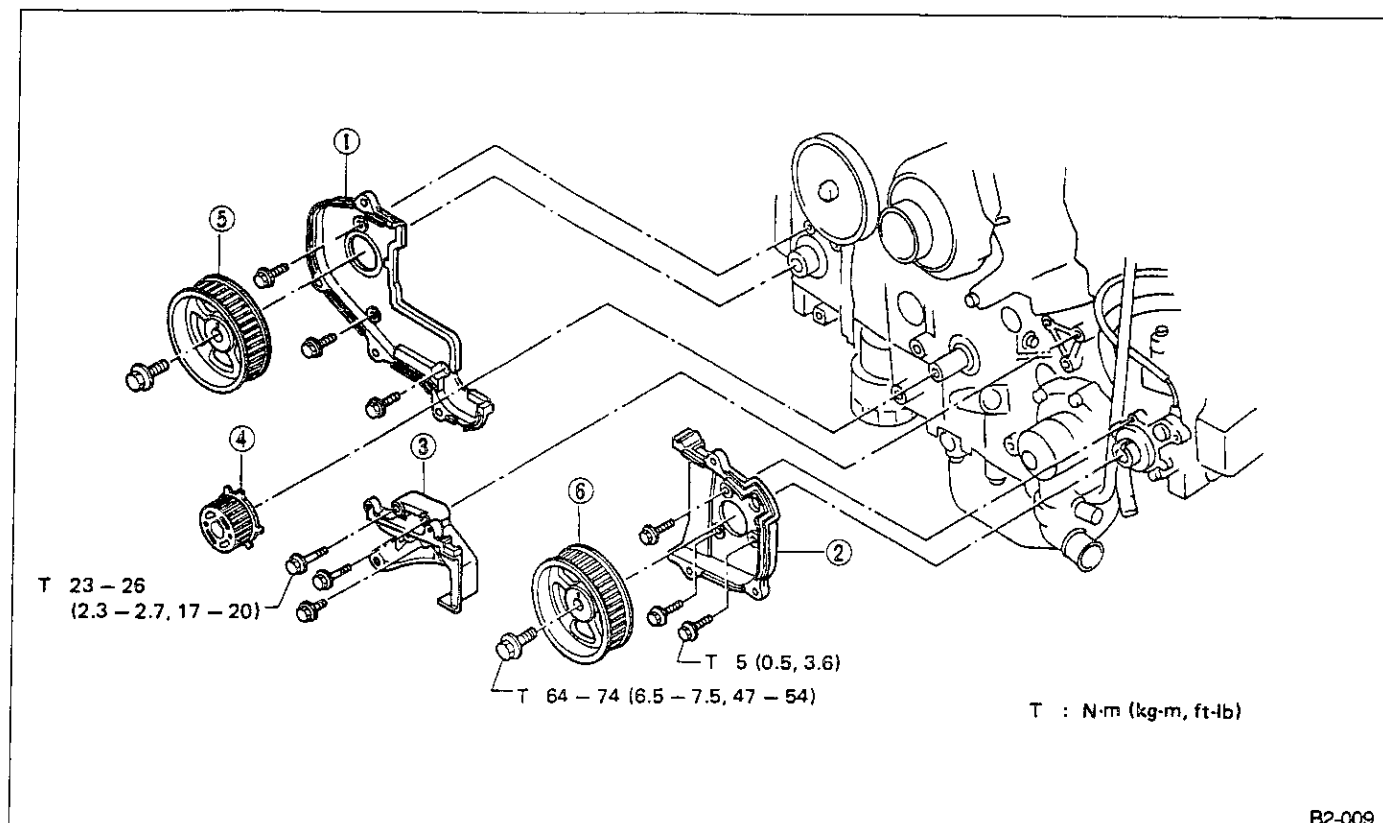
C: INSTALLATION**1. SPROCKET**

Fig. 26

- 1) Install right-hand belt cover No. 2.
 - 2) Install left-hand belt cover No. 2.
 - 3) Install tensioner bracket.
 - 4) Install crankshaft sprocket.
 - 5) Install right-hand camshaft sprocket.
- To lock camshaft, use CAMSHAFT SPROCKET WRENCH.

- 6) Install left-hand camshaft sprocket.

Do not confuse left- and right-hand camshaft sprockets during installation. The left-hand camshaft sprocket is identified by a projection used to monitor cam-angle sensor.

2. BELT TENSIONER AND IDLER

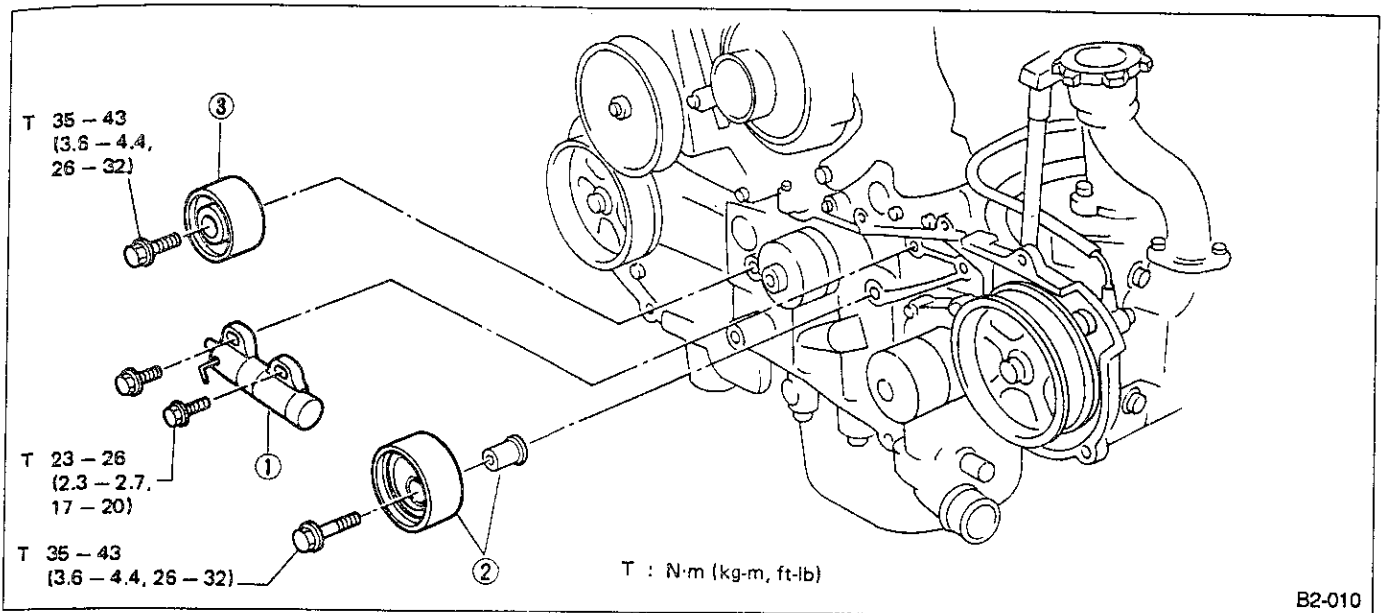


Fig. 27

1) Installation of belt tensioner adjuster.

(1) Insert stopper pin 1.5 mm (0.059 in) dia. into place while pushing tension adjuster rod into body using a press.

a. Do not allow press pressure to exceed 9,807 N (1,000 kg, 2,205 lb).

b. Do not release press pressure until stopper pin is completely inserted.

c. Push tension adjuster rod vertically.

(2) Temporarily tighten bolts while tension adjuster is pushed all the way to the right.

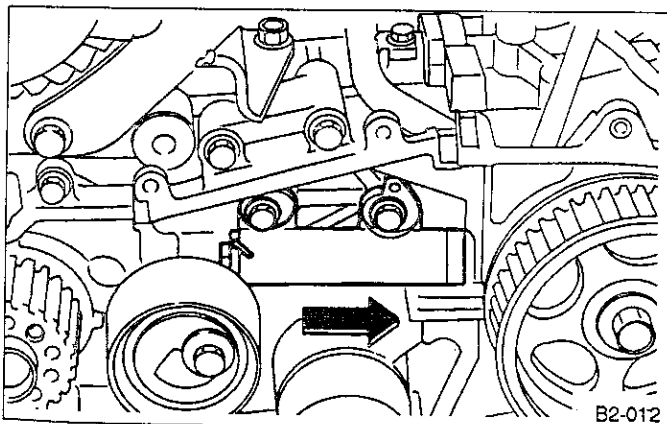


Fig. 28

- 2) Install belt tensioner.
- 3) Install belt idler.

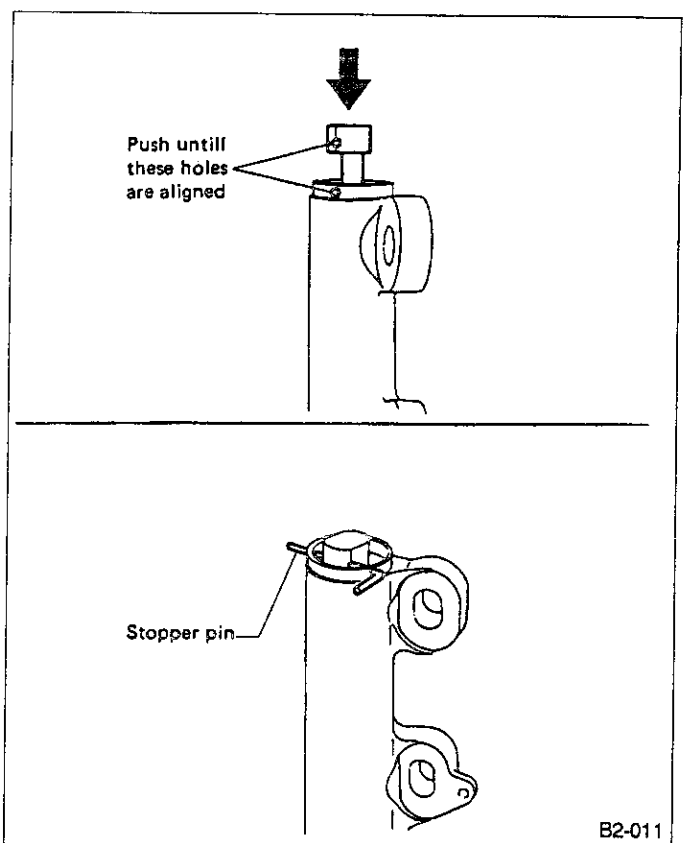


Fig. 29

3. TIMING BELT

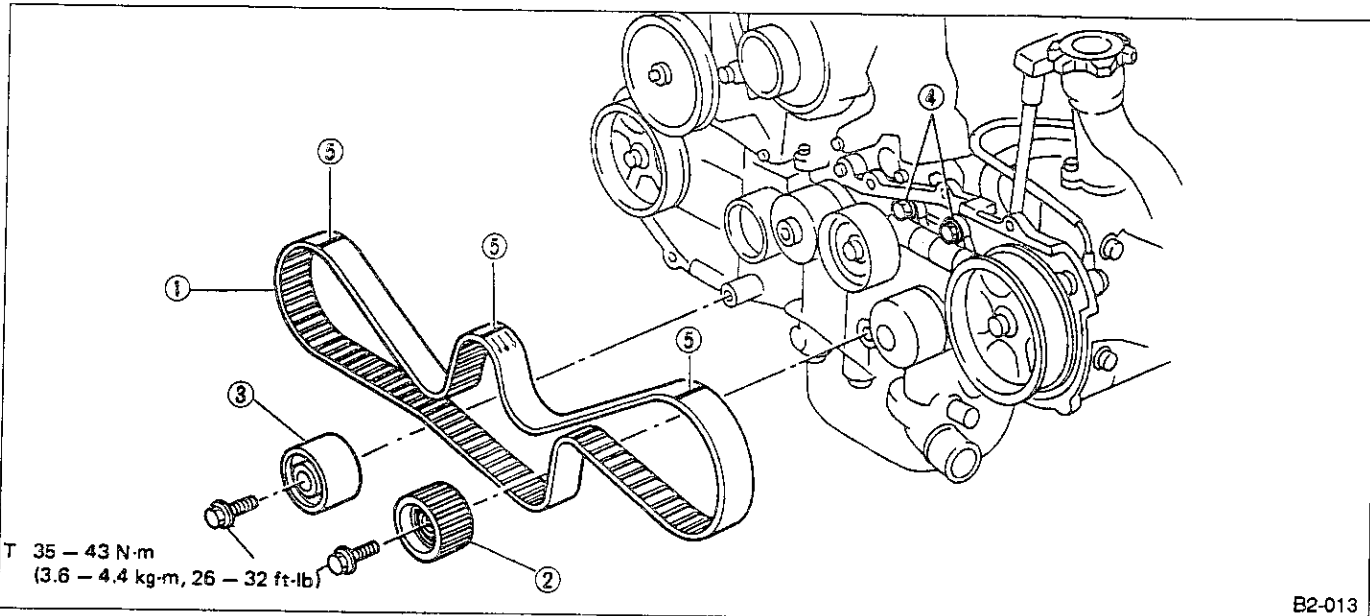


Fig. 30

B2-013

1) Installation of timing belt.

(1) Using SPROCKET WRENCH, turn sprockets so that their alignment marks come to top positions.

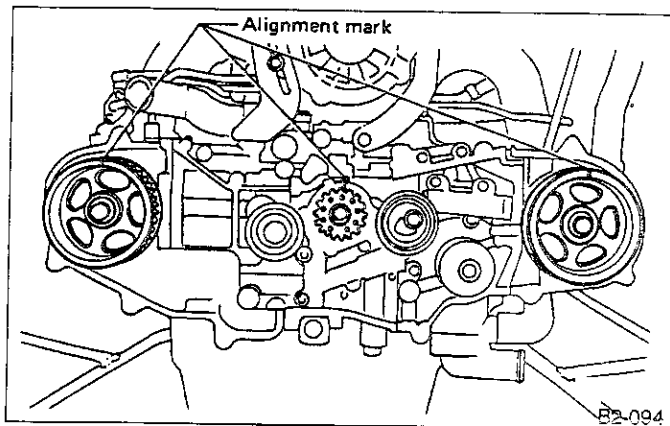


Fig. 31

(2) While aligning alignment mark on timing belt with marks on sprockets, position timing belt properly.

Ensure belt's rotating direction is correct.

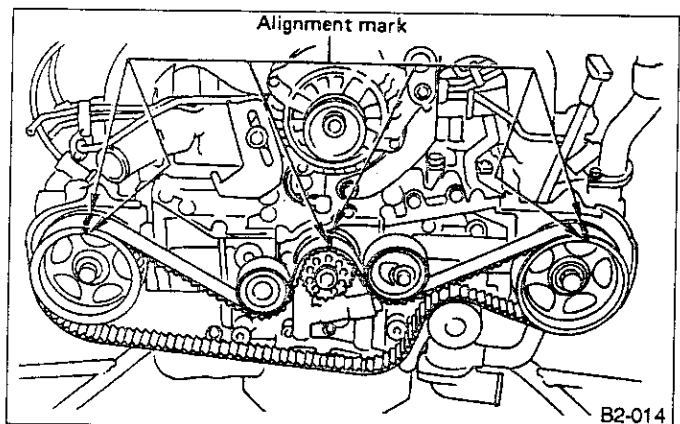


Fig. 32

B2-014

2) Install belt idler No. 2.

3) Install belt idler.

4) Loosen tension adjuster attaching bolts and move adjuster all the way to the left. Tighten the bolts.

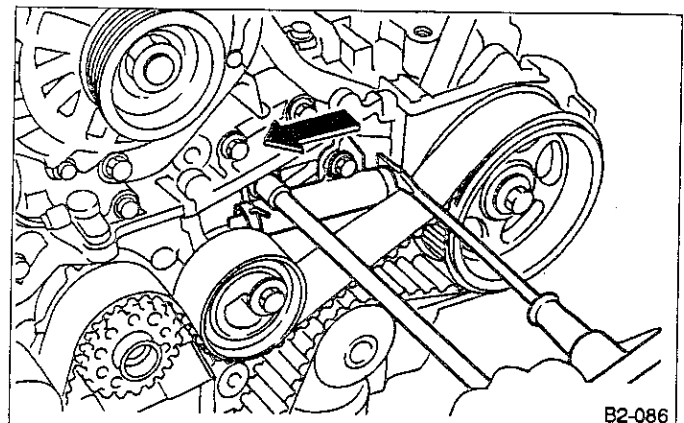


Fig. 33

B2-086

5) After ensuring that the marks on timing belt and sprockets are aligned, remove stopper from tension adjuster.

After properly installing timing belt, remove rocker cover and ensure that the valve lash adjuster contains no air.

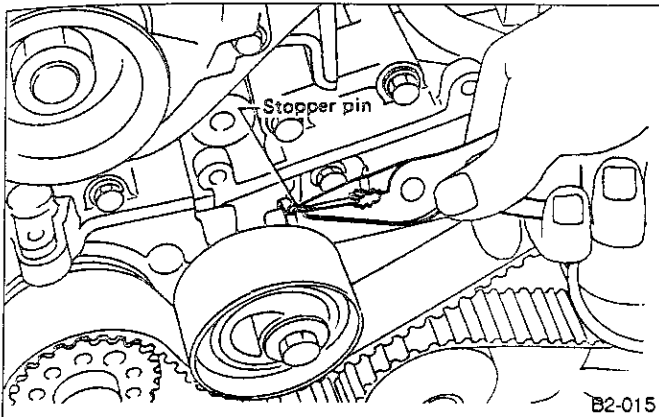


Fig. 34

4. CRANKSHAFT PULLEY AND BELT COVER

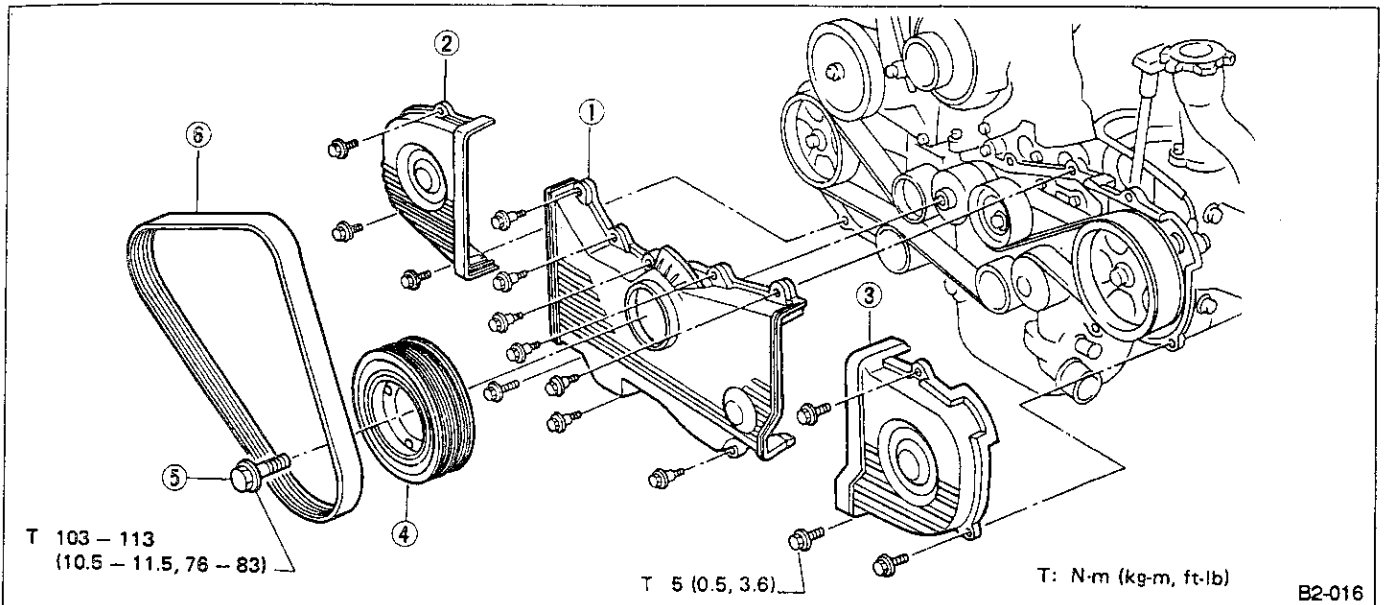


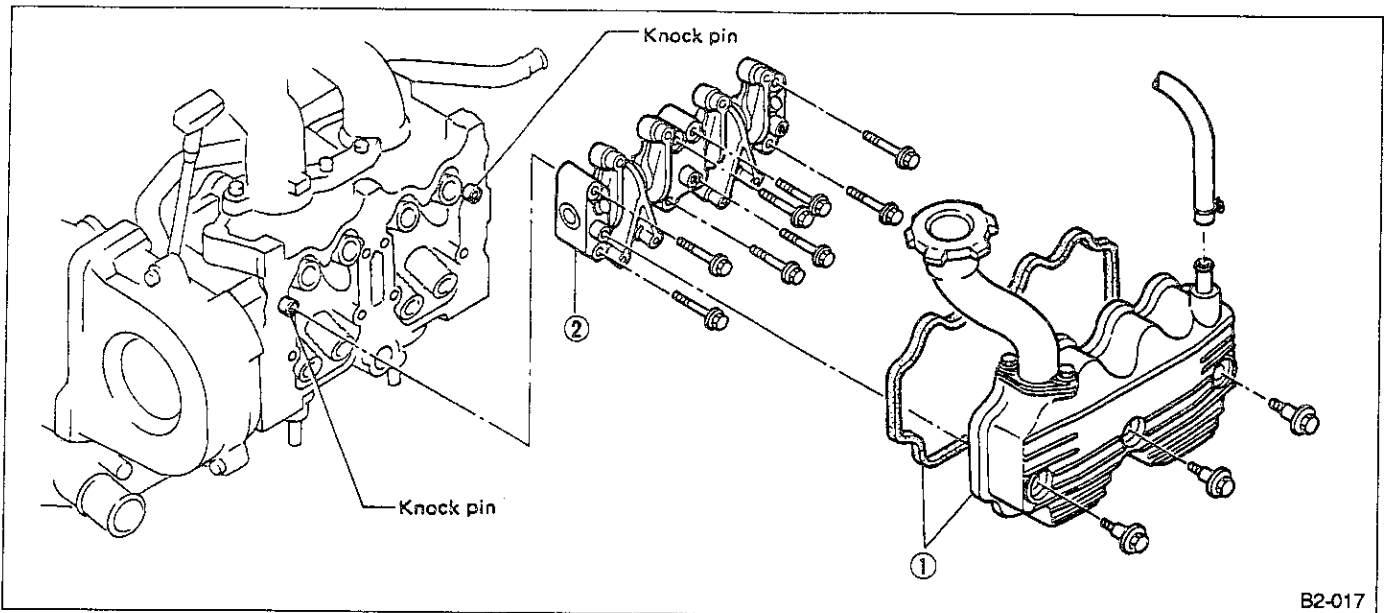
Fig. 35

- 1) Install front belt cover.
- 2) Install right-hand belt cover.
- 3) Install left-hand belt cover.

- 4) Install crankshaft pulley.
- 5) Install pulley bolt.
- 6) Install V-belt.

3. Valve Rocker ASSY

A: REMOVAL



B2-017

Fig. 36

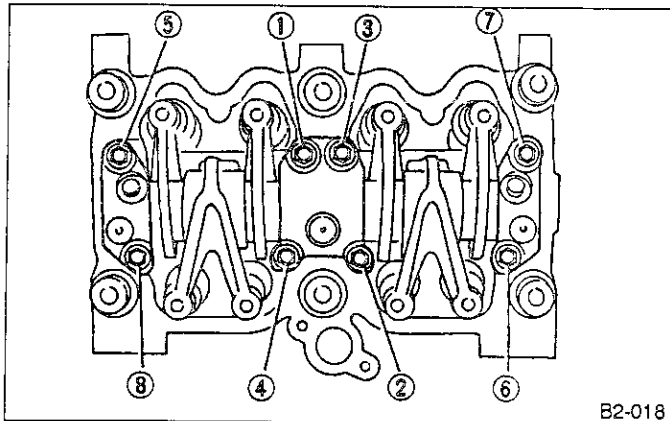
- 1) Disconnect PCV hose and remove rocker cover.
- 2) Removal of valve rocker ASSY
 - (1) Remove bolts ② through ④ in numerical sequence. See Figure.

Leave two or three threads of bolt ① engaged to retain valve rocker ASSY.

- (2) Equally loosen bolts ⑤ through ⑧ all the way, being careful that dowel pin is not gouged.
- (3) Remove valve rocker ASSY.

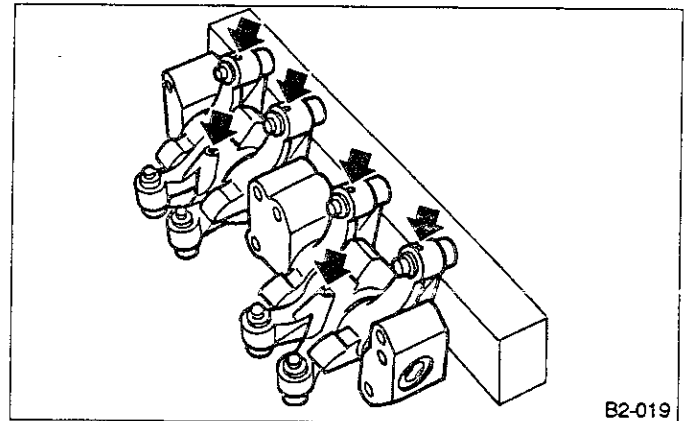
Locate valve rocker ASSY with air vent (on rocker arm) facing upward or dip it in engine oil after removal.

See Figure.



B2-018

Fig. 37



B2-019

Fig. 38

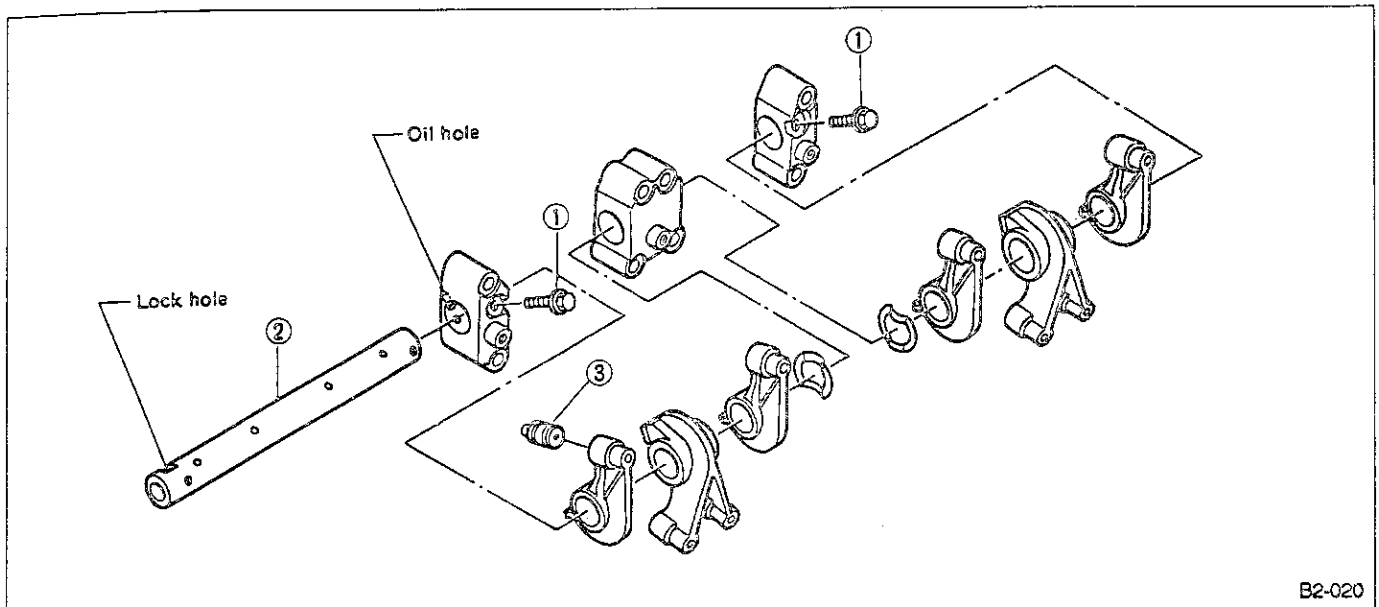
B: DISASSEMBLY

Fig. 39

- 1) Remove bolts which secure rocker shaft.
- 2) Extract rocker shaft. Remove valve rocker arms, springs and shaft supports from rocker shaft.

Arrange all removed parts in order so that they can be installed in their original positions.

Locate rocker arms with air vents facing upward.

- 3) Remove valve lash adjuster from valve rocker.

Do not remove valve lash adjuster unless it requires air bleeding or replacement.

If valve lash adjuster is hard to remove by hand, use pliers. Be careful not to scratch valve lash adjuster.

Dip lash adjuster in engine oil after removal.

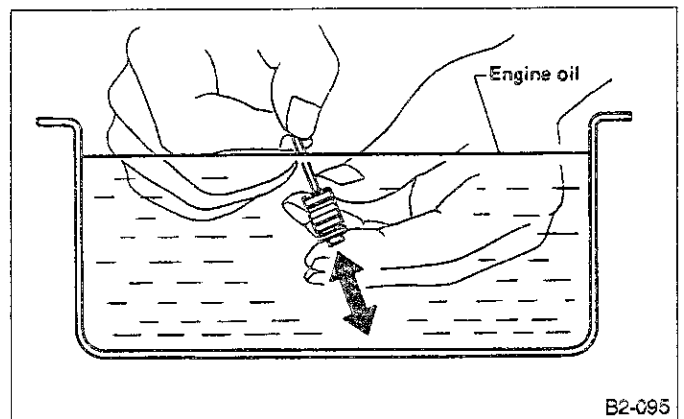


Fig. 40

- 2) Replace valve lash adjuster with a new one if valve contact surface is scratched.

C: INSPECTION**1. VALVE LASH ADJUSTER**

- 1) Bleed air from valve lash adjuster as described below:

(1) While dipping valve lash adjuster in engine oil, as shown in Figure, push check ball in using a 2 mm (0.08 in) dia. round bar.

(2) With check ball pushed in, manually move plunger up and down at one-second intervals until air bubbles disappear.

(3) After air bubbles disappear, remove round bar and quickly push plunger in to ensure it is locked. If plunger does not lock properly, replace valve lash adjuster.

Leave lash adjuster (after air is bled) in engine oil until it is ready for installation.

2. VALVE ROCKER ARM

- 1) Measure inside diameter of valve rocker arm and outside diameter of valve rocker shaft, and determine the difference between the two (= oil clearance).

Clearance between arm and shaft:

Standard

0.020 — 0.081 mm (0.0008 — 0.0032 in)

Limit

0.10 mm (0.0039 in)

If oil clearance exceeds specifications, replace valve rocker arm or shaft.

Use the following table as a guide in determining a combination rocker shaft, rocker arm and support.

Rocker shaft	Rocker arm	Support
Make A or (No mark)	Mark "—"	(No mark)
Mark B	Mark "+ "	Mark B [Stamp 3mm dia.]

2) If cam or valve contact surface of valve rocker arm is worn or dented, repair by removing the minimum necessary amount. If worn heavily, replace valve rocker arm.

D: ASSEMBLY

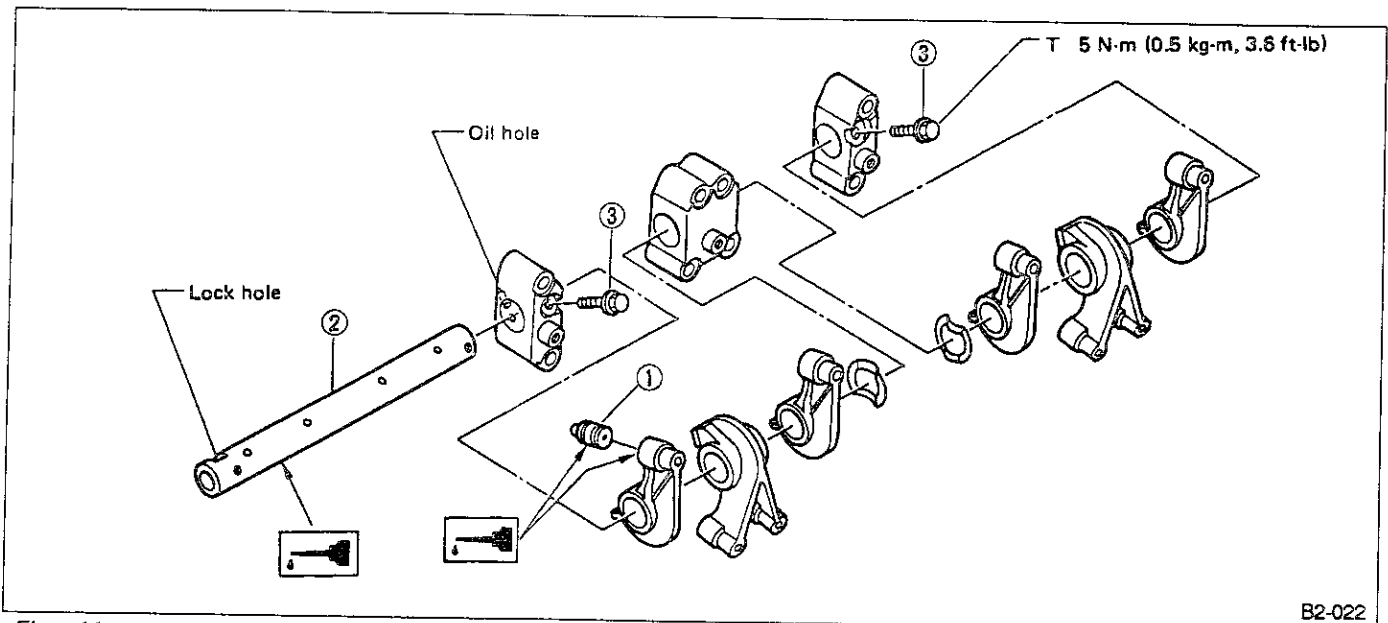


Fig. 41

1) After bleeding air from valve lash adjuster, position valve lash adjuster in valve rocker arm while dipping in engine oil. (Ref. to [W2C1].)

Fill rocker arm oil reservoir chamber with engine oil. Install a new valve lash adjuster O-ring, being careful not to scratch it.

Do not attempt to rotate valve lash adjuster during installation.

2) Arrange valve rocker arms, springs and shaft supports in assembly order and insert valve rocker shaft. Ensure that cutout portion of rocker shaft faces oil holes in shaft supports.

Valve rocker arms, rocker shaft and shaft supports have identification marks. Ensure parts with same markings are properly assembled.

3) Install valve rocker shaft securing bolts while aligning shaft "lock" holes with bolts.

3. VALVE ROCKER SHAFT

Visually check oil relief valve of shaft end for any of the following abnormalities.

- Breaks in check ball body
- Foreign particles caught in valve spring
- Oil leaks at check ball

Repair or replace valve rocker shaft as necessary.

E: INSTALLATION

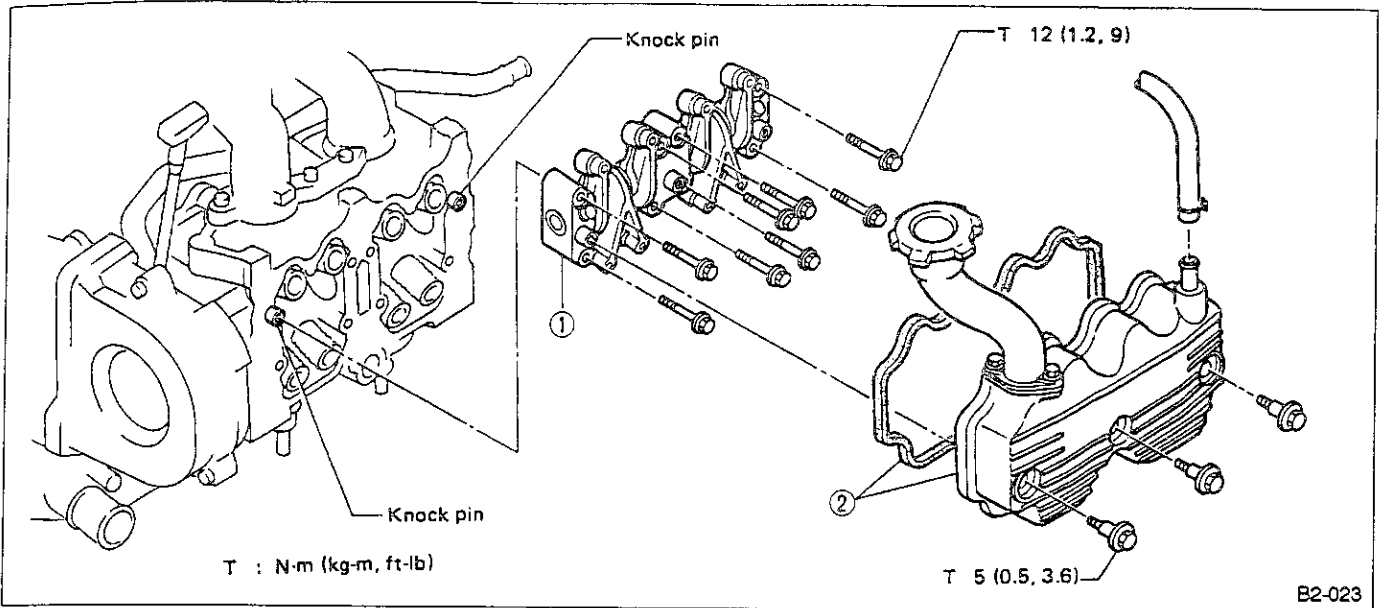


Fig. 42

1) Installation of valve rocker ASSY

- (1) Temporarily tighten bolts ① through ④ equally (as shown in Figure. Do not allow valve rocker ASSY to gouge dowel pins.
- (2) Tighten bolts ⑤ through ⑧ to specified torque.
- (3) Tighten bolts ① through ④ to specified torque.

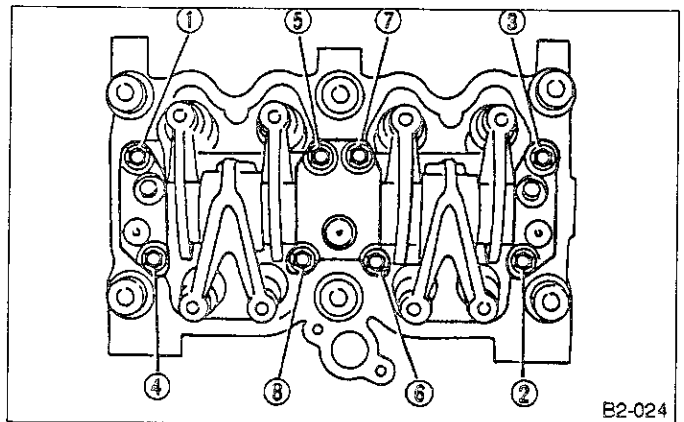


Fig. 43

- 2) Install rocker cover and connect PCV hose.

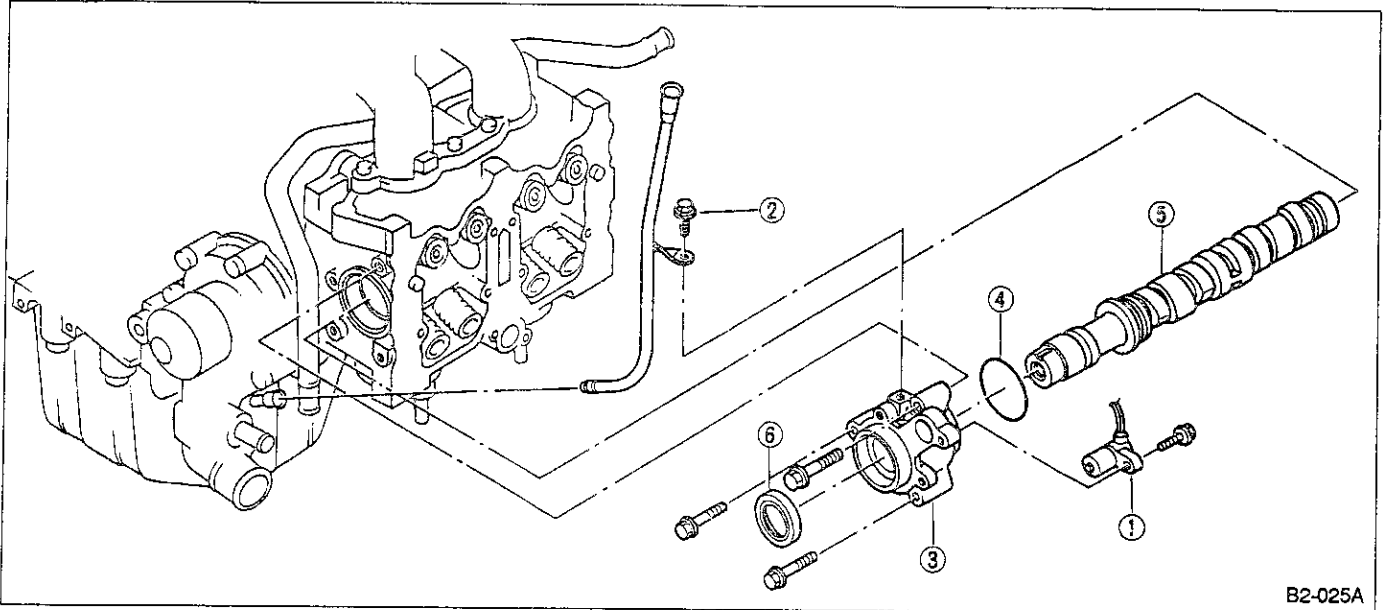
4. Camshaft

A: REMOVAL

1. RELATED PARTS

- 1) Remove timing belt, camshaft sprockets and related parts.
(Ref. to 2. Timing Belt [W2A0].)
- 2) Remove valve rocker ASSY.
(Ref. to 3. Valve Rocker ASSY [W3A0].)

2. CAMSHAFT LH

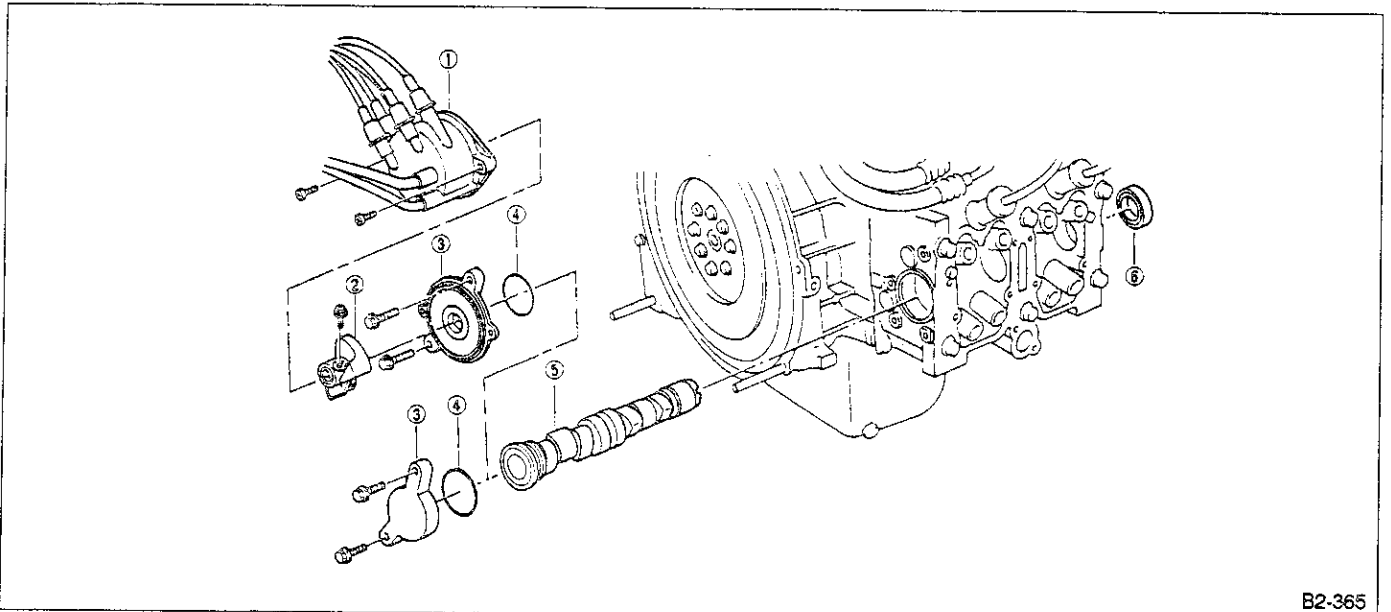


B2-025A

Fig. 44

- 1) Remove cam-angle sensor. (Except carburetor model)
 - 2) Remove oil level gauge guide attaching bolt.
 - 3) Remove camshaft support LH.
 - 4) Remove O-ring.
 - 5) Remove camshaft LH.
 - 6) Remove oil seal.
- Do not remove oil seal unless necessary.

3. CAMSHAFT RH



B2-365

Fig. 45

- 1) Remove distributor [SPFI and Carburetor].
- 2) Remove rotor [SPFI].
- 3) Remove camshaft support RH.
- 4) Remove O-ring.

- 5) Remove camshaft.
 - 6) Remove oil seal.
- Do not remove oil seal unless necessary.

B: INSPECTION

1. CAMSHAFT

- 1) Measure the bend, and repair or replace if necessary.

Limit:
0.025 mm (0.0010 in)

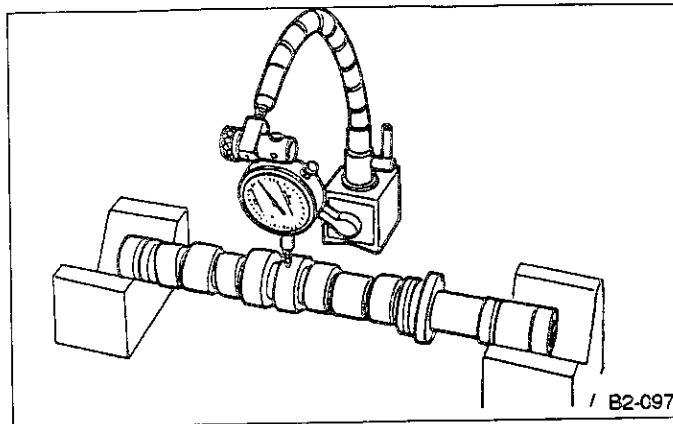


Fig. 46

- 2) Check journal for damage and wear. Replace if faulty.
- 3) Measure outside diameter of camshaft journal and inside diameter of cylinder head journal, and determine the difference between the two (= oil clearance). If oil clearance exceeds specifications, replace camshaft or cylinder head as necessary.

Unit: mm (in)

Item	Right-hand camshaft	Front	Center	Rear
	Left-hand camshaft	Rear	Center	Front
Clearance at journal	Standard	0.055 — 0.090 (0.0022 — 0.0035)		
	Limit	0.10 (0.0039)		
Camshaft journal O.D.		31.935 — 31.950 (1.2573 — 1.2579)	37.435 — 37.450 (1.4738 — 1.4744)	37.935 — 37.950 (1.4935 — 1.4941)
Journal hole I.D.		32.005 — 32.025 (1.2600 — 1.2608)	37.505 — 37.525 (1.4766 — 1.4774)	38.005 — 38.025 (1.4963 — 1.4970)

- 4) Check cam face condition; remove minor faults by grinding with oil stone. Measure the cam height H; replace if the limit has been exceeded.

Standard cam height "H":

- 2200cc
32.390 — 32.490 mm (1.2752 — 1.2791 in)
- 2000cc
32.364 — 32.464 mm (1.2742 — 1.2781 in)
- 1300cc, 1600cc
32.495 — 32.595 mm (1.2793 — 1.2833 in)

Wear limit:
0.3 mm (0.012 in)

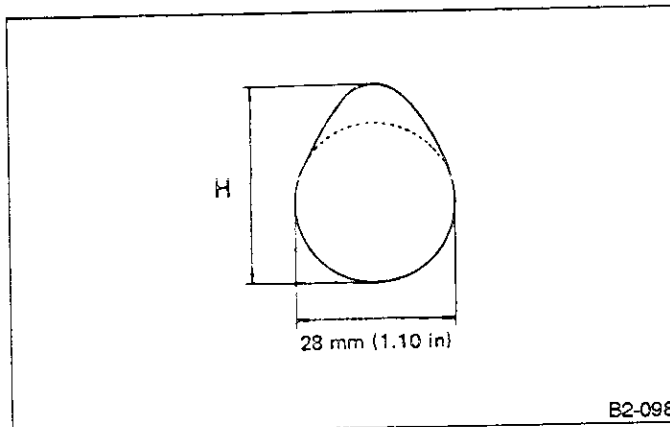


Fig. 47

2. CAMSHAFT SUPPORT

Measure the thrust clearance of camshaft with dial gauge. If the clearance exceeds the limit, replace camshaft support.

Standard:

0.03 — 0.26 mm (0.0012 — 0.0102 in)

Limit: 0.35 mm (0.0138 in)

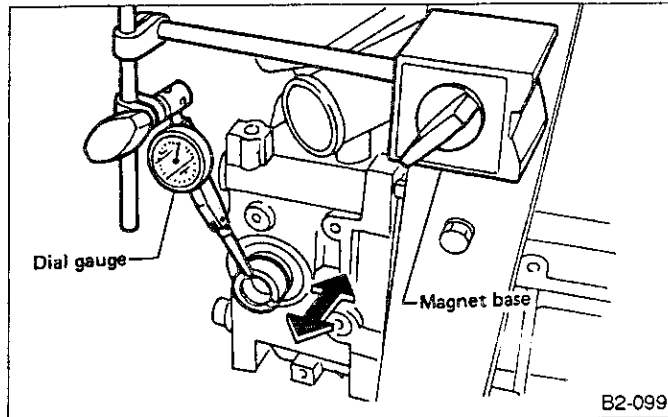


Fig. 48

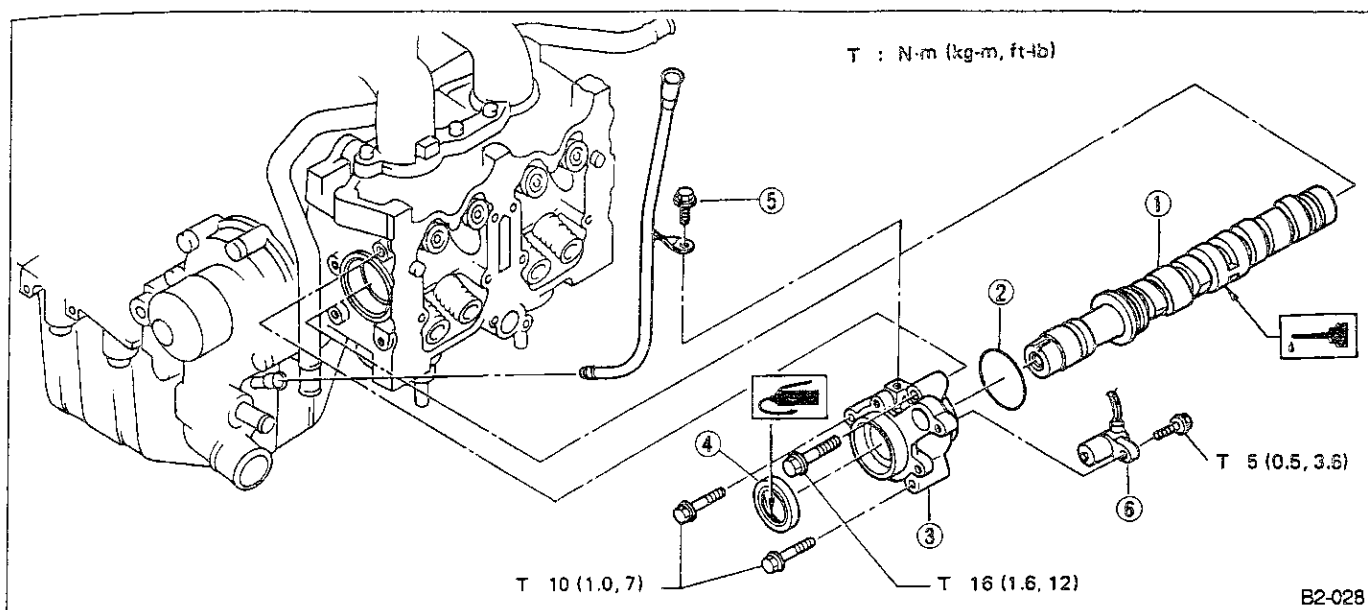
C: INSTALLATION**1. CAMSHAFT LH**

Fig. 49

- 1) Apply a coat of engine oil to camshaft journals and install camshaft LH.
- 2) Install O-ring to camshaft support.
- 3) Install camshaft support.
- 4) Apply a coat of grease to oil seal lips and install oil seal on camshaft support.

Use a new oil seal.

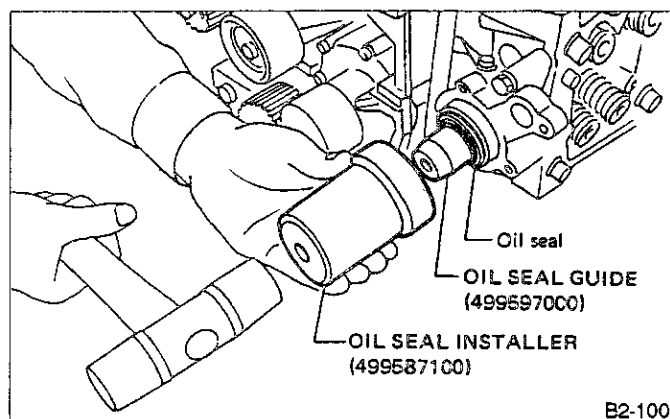
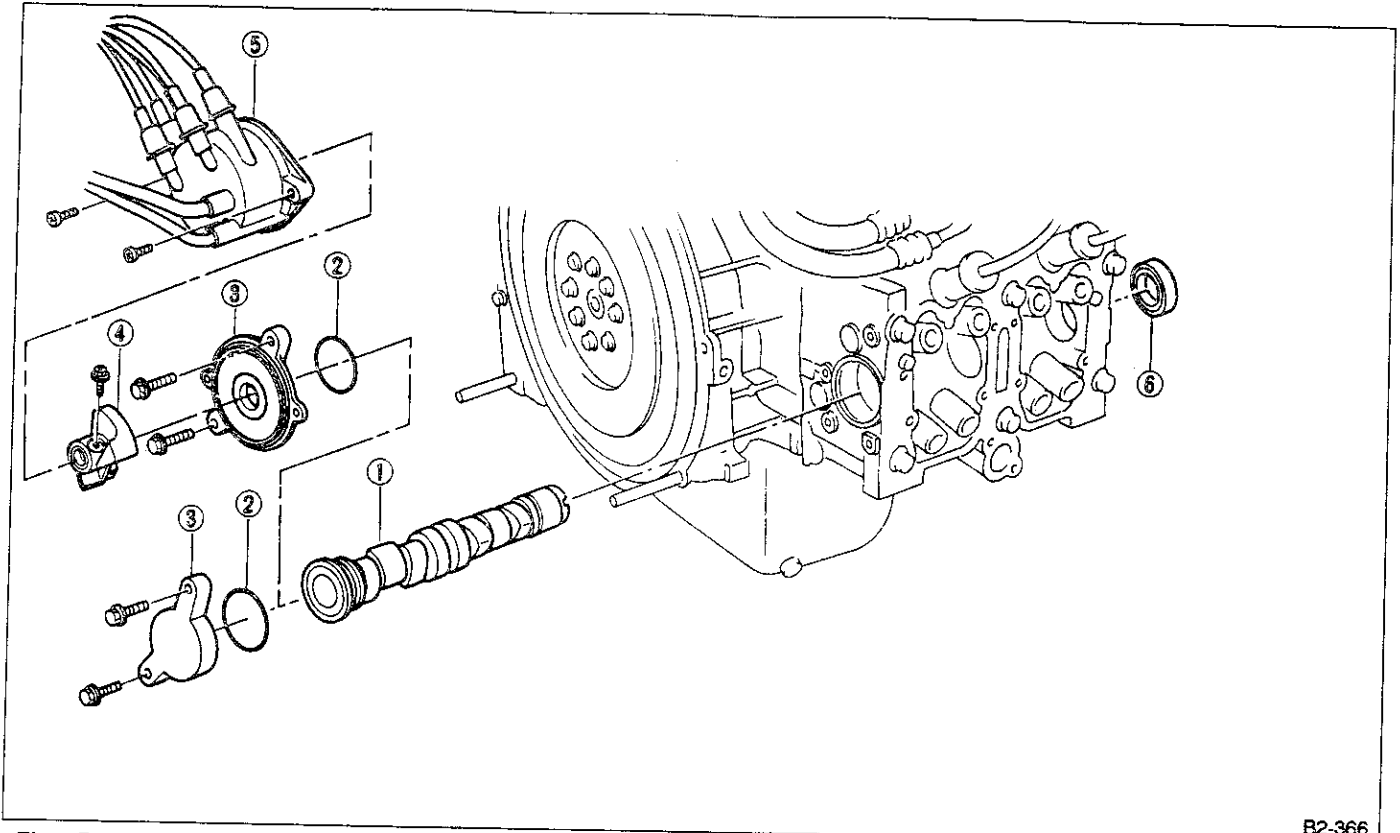


Fig. 50

- 5) Install oil level gauge guide bolt.
- 6) Install cam-angle sensor. (Except carburetor model)

2. CAMSHAFT RH

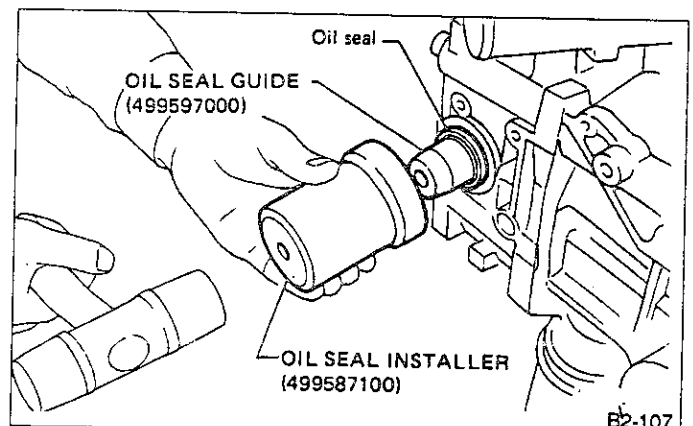


B2-366

Fig. 51

- 1) Apply a coat of engine oil to camshaft journals and install camshaft RH.
- 2) Install O-ring to camshaft support.
- 3) Install camshaft support.
- 4) Install rotor [SPFI].
- 5) Install distributor [SPFI and Carburetor].
- 6) Install oil seal.

Use a new oil seal.



B2-107

Fig. 52

3. RELATED PARTS

- 1) Install valve rocker ASSY.
(Ref. to 3. Valve Rocker ASSY [W3E0].)
- 2) Install timing belt, camshaft sprockets and related parts.
(Ref. to 2. Timing Belt [W2C0].)

5. Cylinder Head

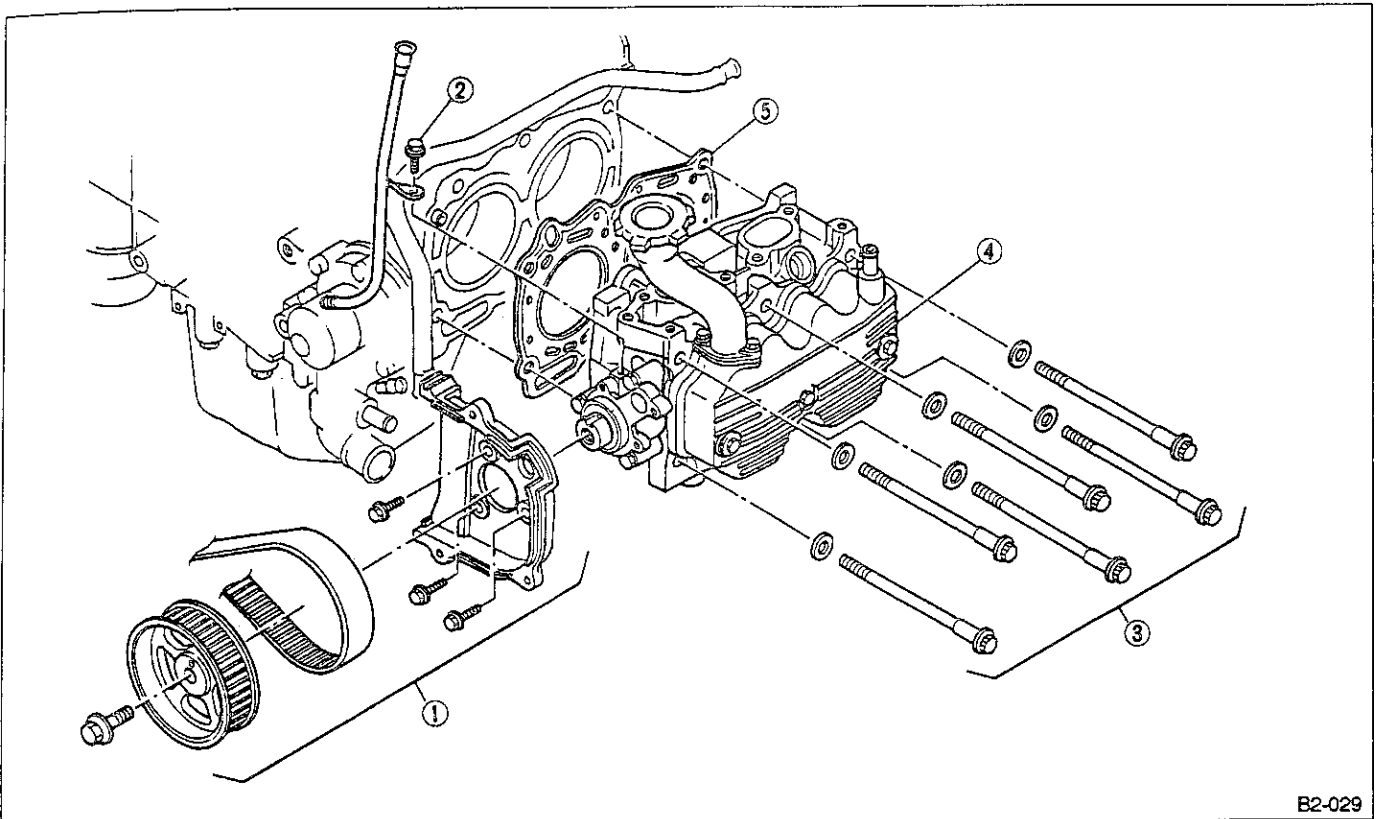
A: REMOVAL

1. INTAKE MANIFOLD

- 1) Remove V-belt.
- 2) Remove power steering pump.
- 3) Remove alternator, air conditioner compressor and brackets.

2. CYLINDER HEAD

- 4) Remove hoses and tubes from cylinder block.
- 5) Disconnect each connector and/or remove connector bracket.
- 6) Remove crank angle sensor, cam angle sensor and knock sensor [SPFI and MPFI].
- 7) Remove intake manifold ASSY and gasket.
- 8) Remove water pipe [MPFI].



B2-029

Fig. 53

- 1) Remove timing belt, camshaft sprocket and related parts.

(Ref. to 2. Timing Belt [W2A0].)

- 2) Remove oil level gauge guide attaching bolt (left hand only).
- 3) Remove cylinder head bolts in numerical sequence shown in Figure.

Leave bolts ① and ④ engaged by three or four threads to prevent cylinder head from falling.

- 4) While tapping cylinder head with a plastic hammer, separate it from cylinder block.

Remove bolts ① and ④ to remove cylinder head.

- 5) Remove cylinder head gasket.

- 6) Similarly, remove right-hand cylinder head.

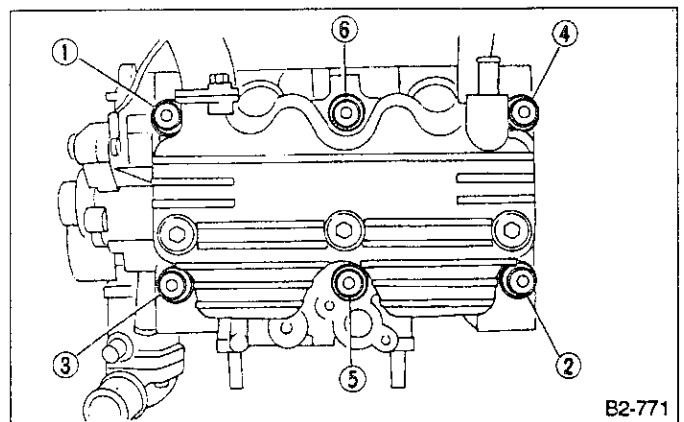


Fig. 54

B2-771

B: DISASSEMBLY

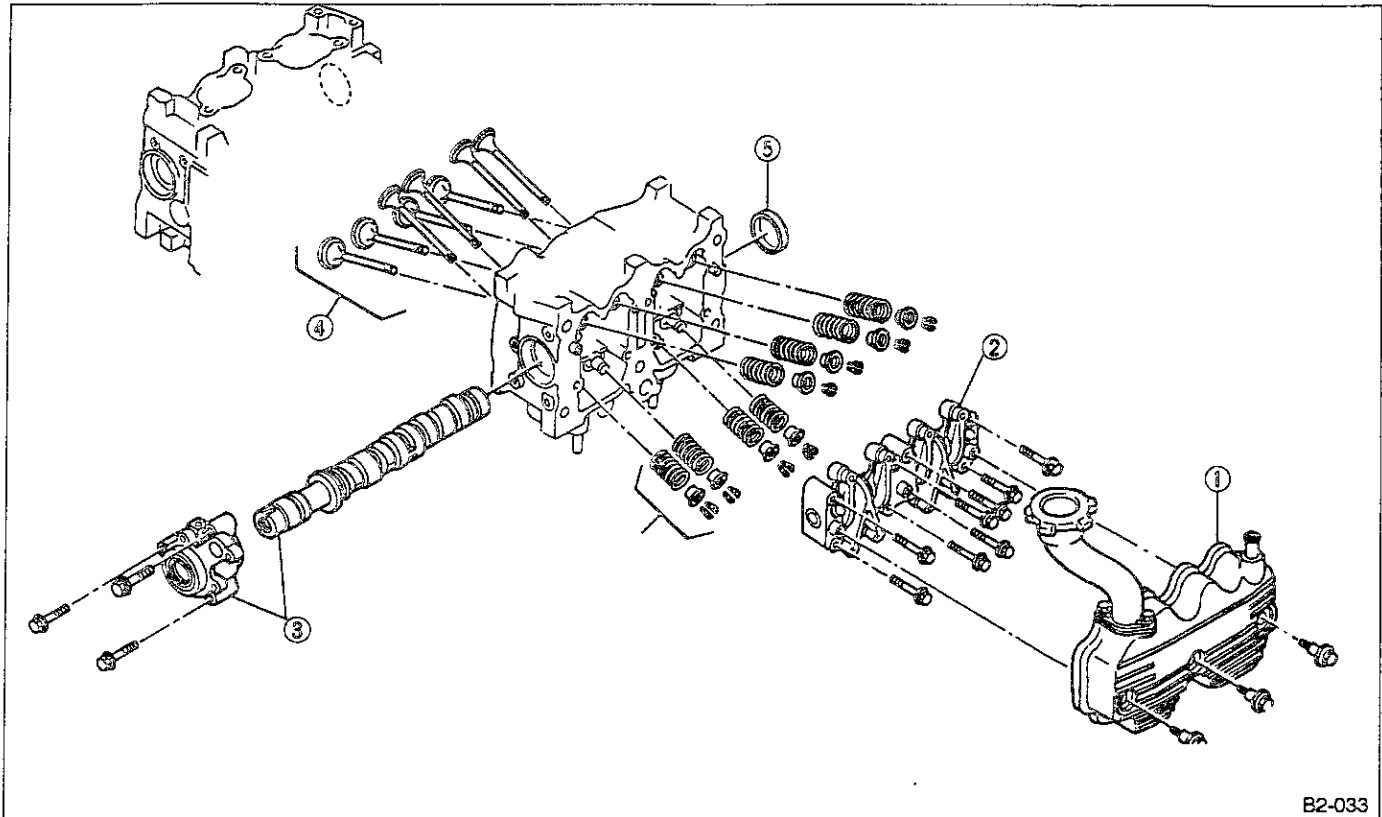


Fig. 55

- 1) Remove rocker cover.
 - 2) Remove valve rocker ASSY.
(Ref. to 3. Valve Rocker ASSY [W3A0].)
 - 3) Remove camshaft and support.
(Ref. to 4. Camshaft [W4A0].)
 - 4) Compress the valve spring and remove the valve spring retainer key. Remove each valve and valve spring.
- a.** Mark each valve to prevent confusion.
b. Use extreme care not to damage the lips of the intake valve oil seals and exhaust valve oil seals.

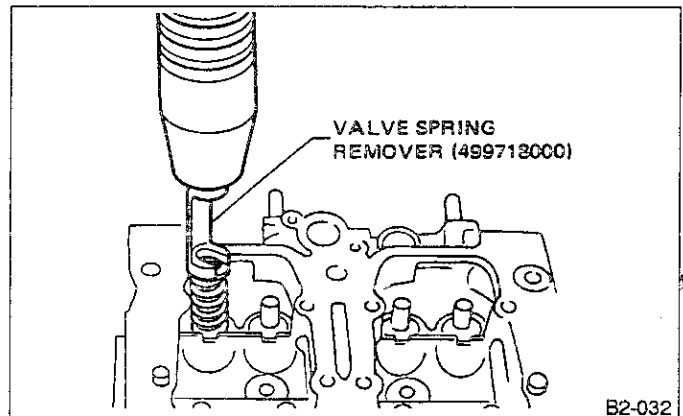


Fig. 56

- 5) Removal of plug (cylinder head LH).
Do not remove plug unless necessary.

C: INSPECTION**1. CYLINDER HEAD**

- 1) Make sure that no crack or other damage exists. In addition to visual inspection, inspect important areas by means of red check.
 - 2) Measure the warping of the cylinder head surface that mates with crankcase by using a straight edge and thickness gauge.
- If the warping exceeds 0.05 mm (0.0020 in), regrind the surface with a surface grinder.

Warping limit:

0.05 mm (0.0020 in)

Grinding limit:

0.3 mm (0.012 in)

Standard height of cylinder head:

98.3 mm (3.870 in)

Uneven torque for the cylinder head nuts can cause warping. When reassembling, pay special attention to the torque so as to tighten evenly.

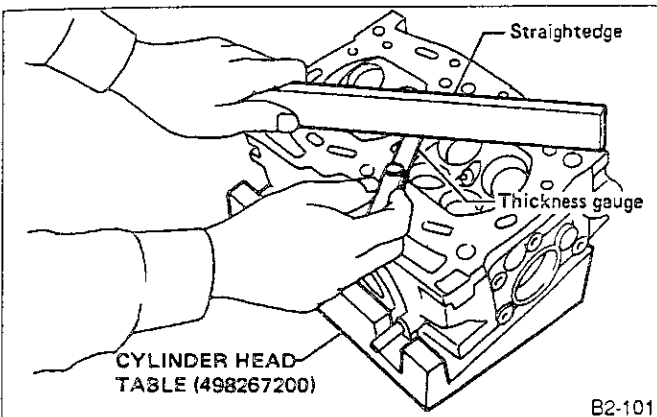


Fig. 57

2. VALVE SEAT

Inspect intake and exhaust valve seats, and correct the contact surfaces with valve seat cutter if they are defective or when valve guides are replaced.

W:**Intake****Standard**

0.7 mm (0.028 in)

Limit

1.4 mm (0.055 in)

Exhaust**Standard**

1.0 mm (0.039 in)

Limit

1.8 mm (0.071 in)

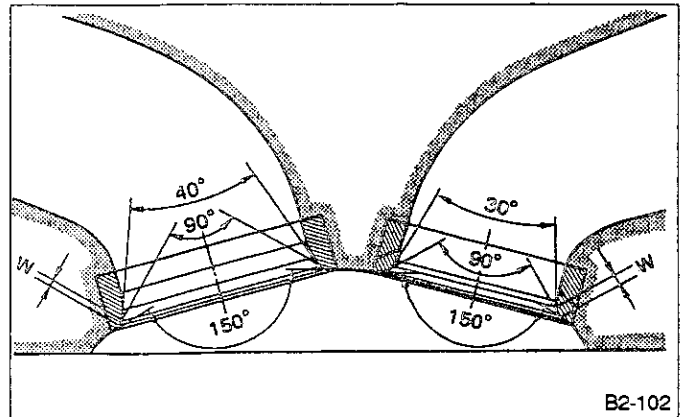


Fig. 58

3. VALVE GUIDE

- 1) Check the clearance between valve guide and stem. The clearance can be checked by measuring the outside diameter of valve stem and the inside diameter of valve guide with outside and inside micrometers respectively.

Clearance between the valve guide and valve stem:**Standard****Intake**

0.035 — 0.062 mm (0.0014 — 0.0024 in)

Exhaust

0.040 — 0.067 mm (0.0016 — 0.0026 in)

Limit

0.15 mm (0.0059 in)

Valve guide inner diameters:

6.00 — 6.012 mm (0.2362 — 0.2367 in)

Valve stem outer diameter:**Intake**

5.950 — 5.965 mm (0.2343-0.2348 in)

Exhaust

5.945 — 5.960 mm (0.2341 — 0.2346 in)

- 2) If the clearance between valve guide and stem exceeds the specification, replace guide as follows:

- (1) Place cylinder head on CYLINDER HEAD TABLE with the combustion chamber upward so that valve guides enter the holes in CYLINDER HEAD TABLE.
- (2) Insert VALVE GUIDE REMOVER into valve guide and press it down to remove valve guide.

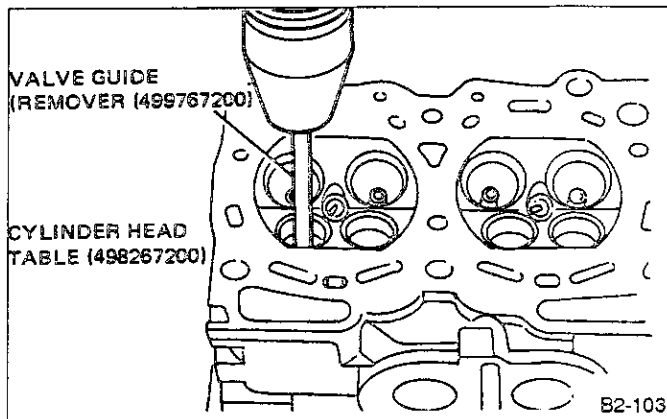


Fig. 59

(3) Turn cylinder head upside down and place VALVE GUIDE ADJUSTER as shown in the figure.

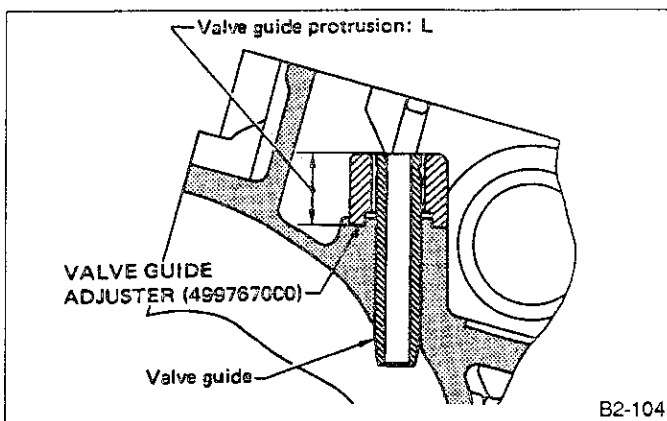


Fig. 60

(4) Before installing new valve guide, make sure that neither scratches nor damages exist on the inside surface of the valve guide holes in cylinder head.

(5) Put new valve guide, coated with sufficient oil, in cylinder, and insert VALVE GUIDE REMOVER into valve guide. Press in until the valve guide upper end is flush with the upper surface of VALVE GUIDE ADJUSTER.

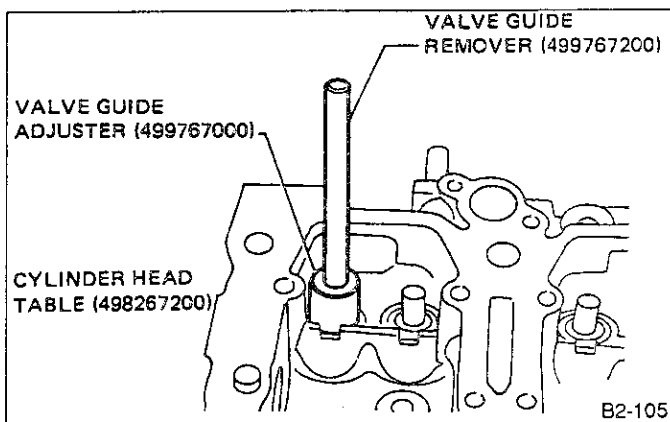


Fig. 61

(6) Check the valve guide protrusion.

Valve guide protrusion: L
17.5 — 18.0 mm (0.689 — 0.709 in)

(7) Ream the inside of valve guide with VALVE GUIDE REAMER (499767400). Gently rotate the reamer clockwise while pressing it lightly into valve guide, and return it also rotating clockwise. After reaming, clean valve guide to remove chips.

- a. Apply engine oil to the reamer when reaming.
- b. If the inner surface of the valve guide is torn, the edge of the reamer should be slightly ground with an oil stone.
- c. If the inner surface of the valve guide becomes lustrous and the reamer does not chip, use a new reamer or remedy the reamer.

(8) Recheck the contact condition between valve and valve seat after replacing valve guide.

4. INTAKE AND EXHAUST VALVE

1) Inspect the flange and stem of valve, and replace if damaged, worn, or deformed, or if "H" is less than the specified limit.

H:

Intake	
Standard	1.0 mm (0.039 in)
Limit	0.8 mm (0.031 in)
Exhaust	
Standard	1.2 mm (0.047 in)
Limit	0.8 mm (0.031 in)
Valve overall length:	
Intake	101.0 mm (3.976 in)
Exhaust	101.2 mm (3.984 in)

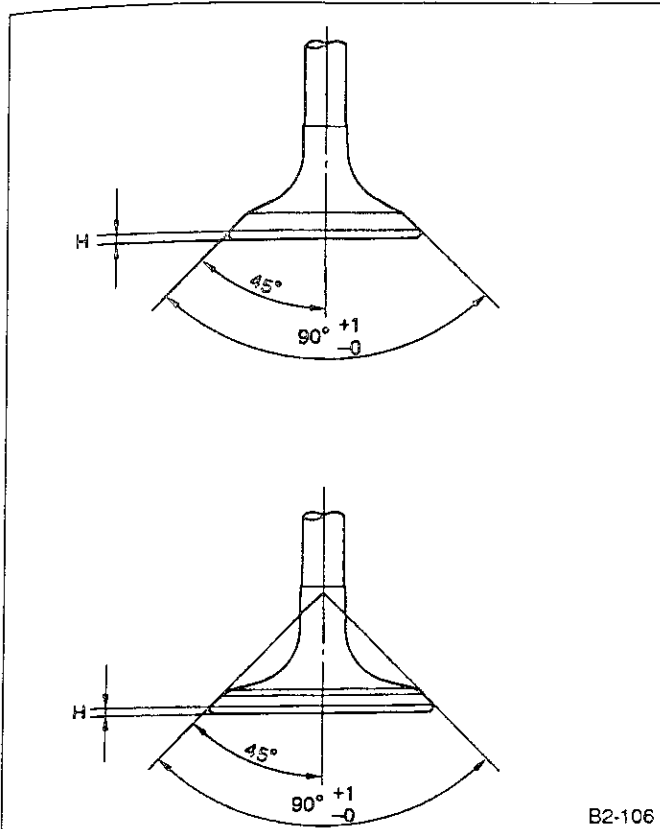


Fig. 62

2) Put a small amount of grinding compound on the seat surface and lap the valve and seat surface. Also refer to Cylinder Head 3) at this time. Install a new intake valve oil seal after lapping.

5. VALVE SPRINGS

1) Check valve springs for damage, free length, and tension. Replace valve spring if it is not to the specifications presented below.

2) To measure the squareness of the valve spring, stand the spring on a surface plate and measure its deflection at the top using a try square.

	Outer spring
Free length	42.99 mm (1.6925 in)
Tension/spring height	190.3 — 219.7 N (19.4 — 22.4 kg, 42.8 — 49.4 lb)/ 37.0 mm (1.457 in)
	401.1 — 461.9 N (40.9 — 47.1 kg, 90.2 — 103.9 lb)/ 29.2 mm (1.150 in)
Squareness	2.5°, 1.9 mm (0.075 in)

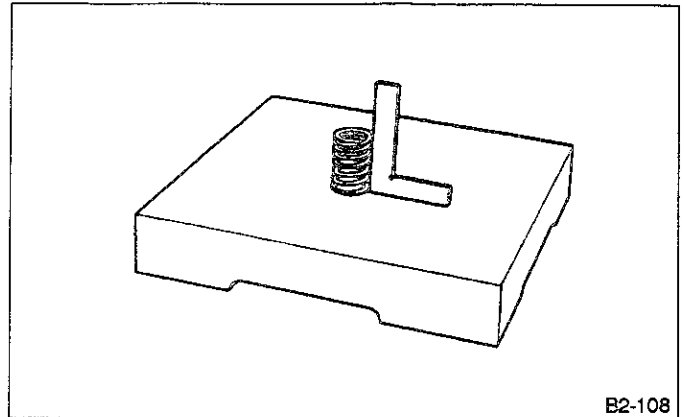


Fig. 63

6. INTAKE AND EXHAUST VALVE OIL SEAL

Replace oil seal with new one, if lip is damaged or spring out of place, or when the surfaces of intake valve and valve seat are reconditioned or intake valve guide is replaced.

Press in oil seal to the specified dimension indicated in the figure, using VALVE OIL SEAL GUIDE.

- Apply engine oil to oil seal before force-fitting.
- Differentiate between intake valve oil seal and exhaust valve oil seal by noting their difference in color.

Color of rubber part:

Intake [Black]

Exhaust [Brown]

Color of spring part:

Intake [White]

Exhaust [White]

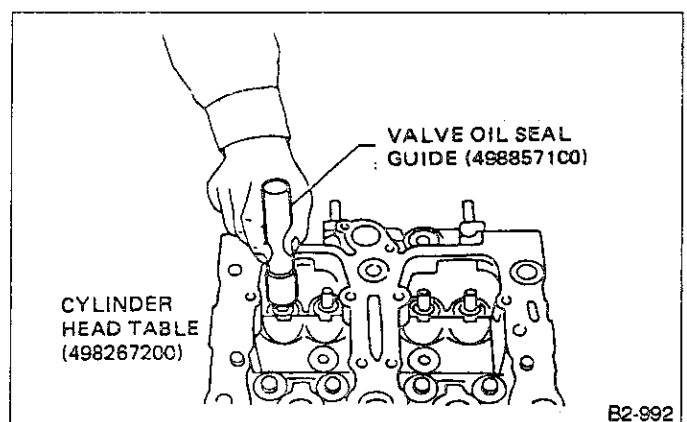


Fig. 64

D: ASSEMBLY

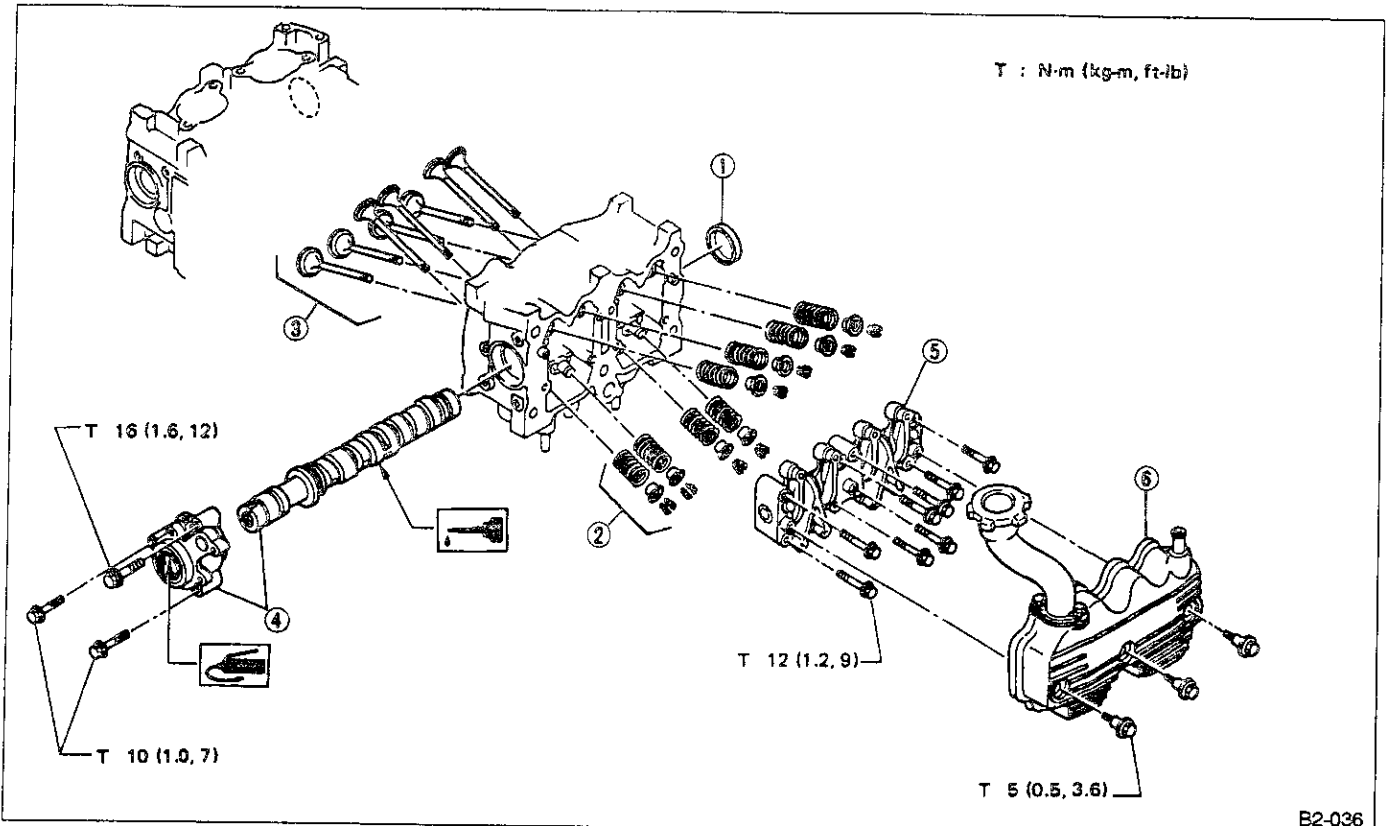


Fig. 65

- 1) Install plug (cylinder head LH).

Special tool:

OIL SEAL INSTALLER (499587100)

- 2) Installation of valve spring and valve.

(1) Coat stem of each valve with engine oil and insert valve into valve guide.

When inserting valve into valve guide, use special care not to damage the oil seal lip.

(2) Install valve spring and retainer.

Be sure to install the valve springs with their close-coiled end facing the seat on the cylinder head.

(3) Compress valve spring and fit valve spring retainer key.

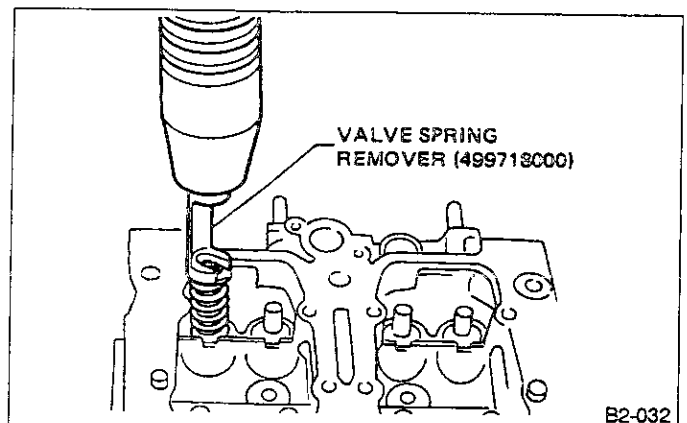


Fig. 66

- (4) After installing, tap valve spring retainers lightly with wooden hammer for better seating.
- 3) Install camshaft and support.
(Ref. to 4. Camshaft [W4C0].)
- 4) Install valve rocker ASSY.
(Ref. to 3. Valve Rocker ASSY [W3E0].)
- 5) Install rocker cover.

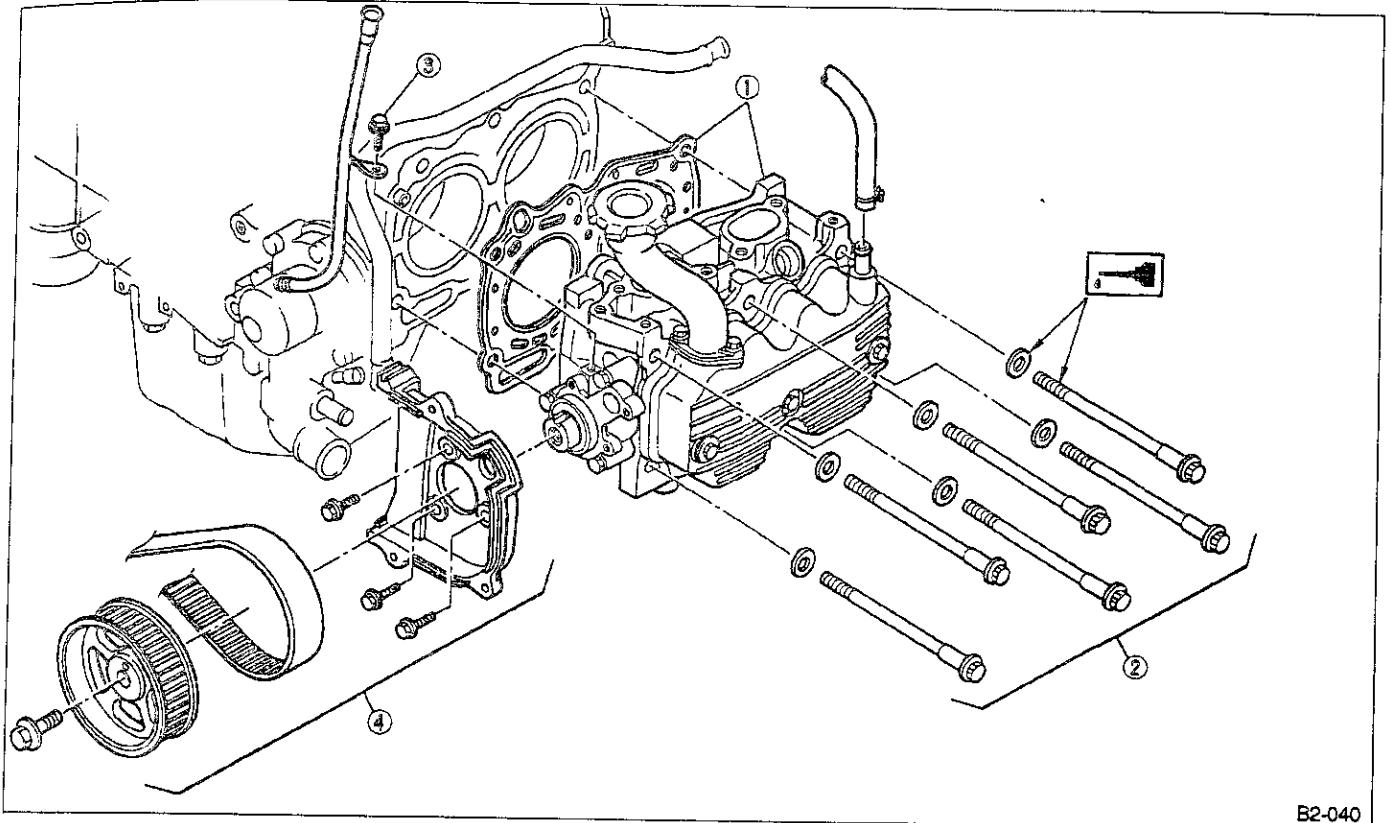
E: INSTALLATION**1. CYLINDER HEAD**

Fig. 67

1) Install cylinder head and gaskets on cylinder block.
Use new cylinder head gaskets.

2) Tighten cylinder head bolts.

(1) Apply a coat of engine oil to washers and bolt threads.

(2) First, tighten bolts to 29 N·m (3.0 kg-m, 22 ft-lb) in the order shown in the Figure. After this, tighten them further to 69 N·m (7.0 kg-m, 51 ft-lb) in the same order.

(3) Back off all bolts by 180°. After this, back them off another 180°.

(4) Tighten bolts ① and ② to 34 N·m (3.5 kg-m, 25 ft-lb).

(5) Tighten bolts ③, ④, ⑤ and ⑥ to 15 N·m (1.5 kg-m, 11 ft-lb).

(6) Tighten all bolts by 80 to 90° in numerical sequence.

Do not tighten bolts more than 90°.

(7) Further tighten all bolts by 80 to 90° in numerical sequence.

Ensure that the total "re-tightening angle" (steps (6) and (7) above) do not exceed 180°.

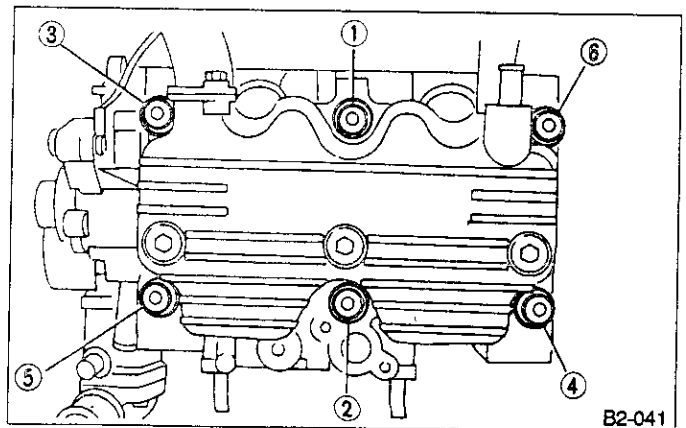


Fig. 68

3) Install oil level gauge guide attaching bolt (left hand only).

4) Install timing belt, camshaft sprocket and related parts.

(Ref. to 2. Timing Belt [W2C0].)

2. INTAKE MANIFOLD

1) Install water pipe [MPFI].

Use new gaskets.

2) Install intake manifold.

Use new gaskets.

3) Install crank angle sensor, cam angle sensor and knock sensor [SPFI and MPFI]. Use dry compressed air to remove foreign particles before installing sensors.

4) Connect each connector and/or install connector bracket.

5) Connect hoses and tubes to cylinder block.

6) Install brackets, alternator and air conditioner compressor.

7) Install power steering pump.

8) Install V-belt.

6. Cylinder Block

A: REMOVAL

1. RELATED PARTS

1) Remove timing belt, camshaft sprocket and related parts.
(Ref. to 2. Timing Belt [W2A0].)

2) Remove intake manifold and cylinder head.
(Ref. to 5. Cylinder Head [W5A0].)

2. OIL PUMP AND WATER PUMP

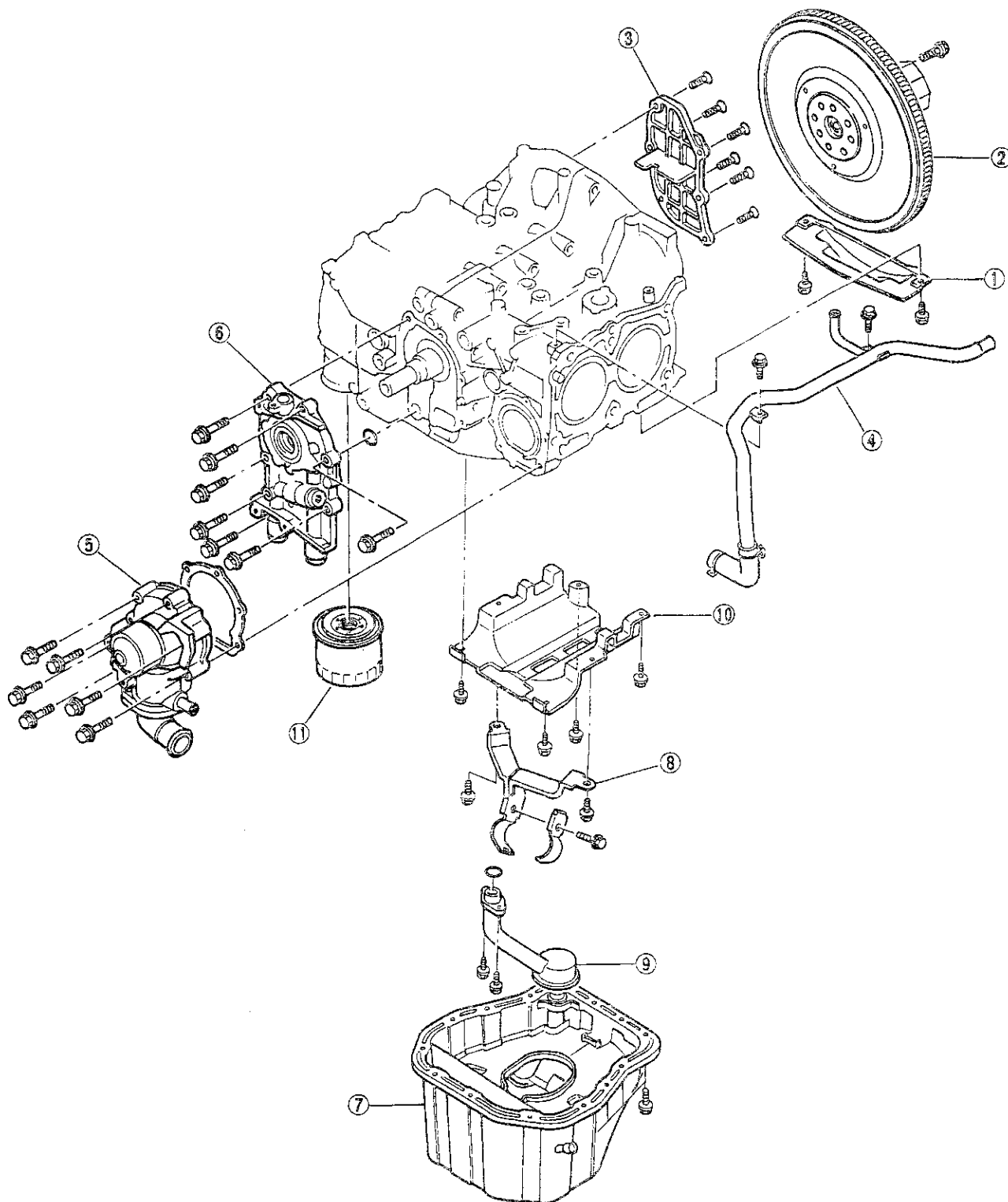


Fig. 69

- 1) Remove housing cover.
 - 2) Remove flywheel or drive plate.
- To lock crankshaft, use CRANKSHAFT STOPPER.

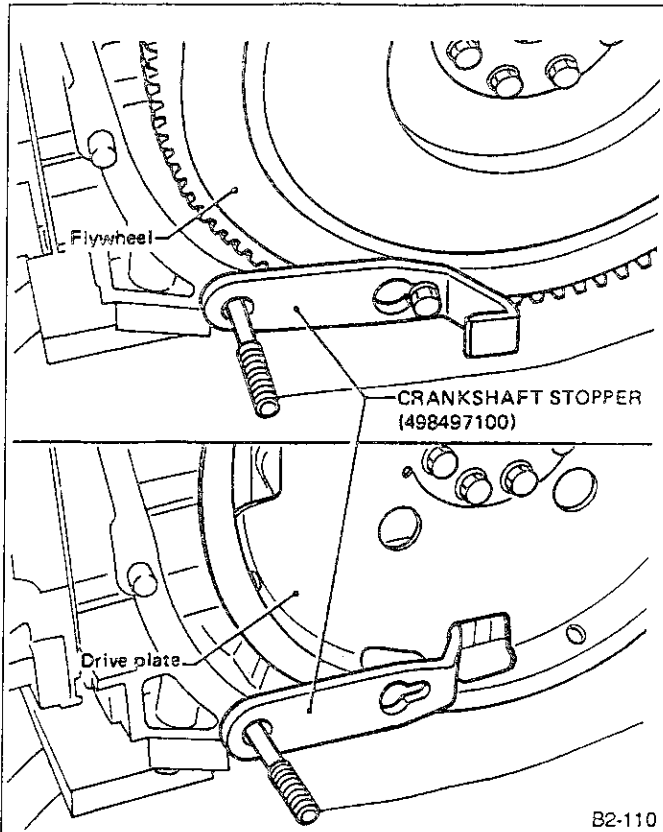


Fig. 70

- 3) Remove oil separator cover.
 - 4) Remove water pipe.
 - 5) Remove water pump.
 - 6) Remove oil pump from cylinder block.
- Use a standard screwdriver as shown in Figure when removing oil pump.

Be careful not to scratch the mating surface of cylinder block and oil pump.

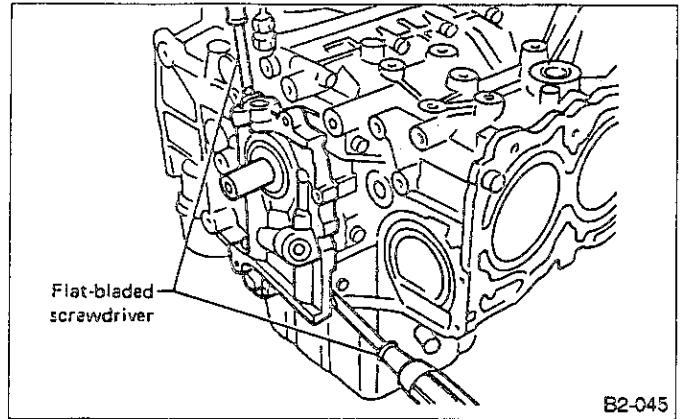


Fig. 71

- 7) Removal of oil pan.

- (1) Turn cylinder block with #2 and #4 piston sides facing upward.
- (2) Remove bolts which secure oil pan to cylinder block.
- (3) Insert a oil-pan cutter blade between cylinder block-to-oil pan clearance and remove oil pan.

Do not use a screwdriver or similar tool in place of oil-pan cutter blade.

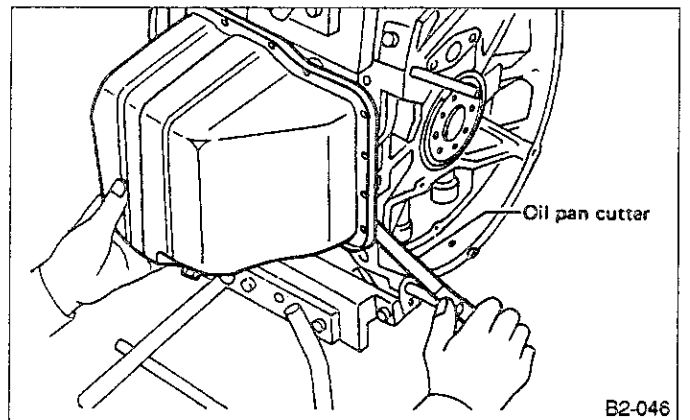
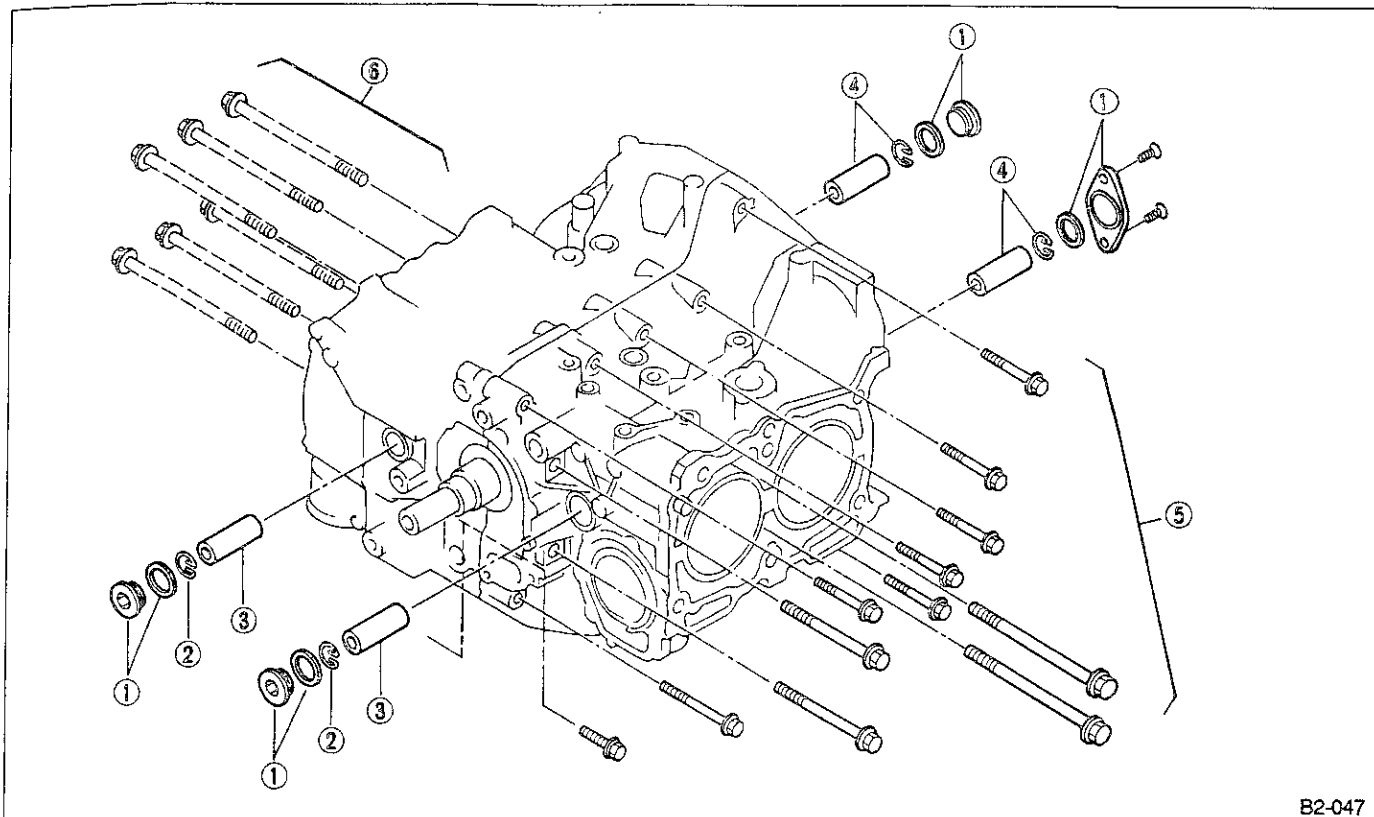


Fig. 72

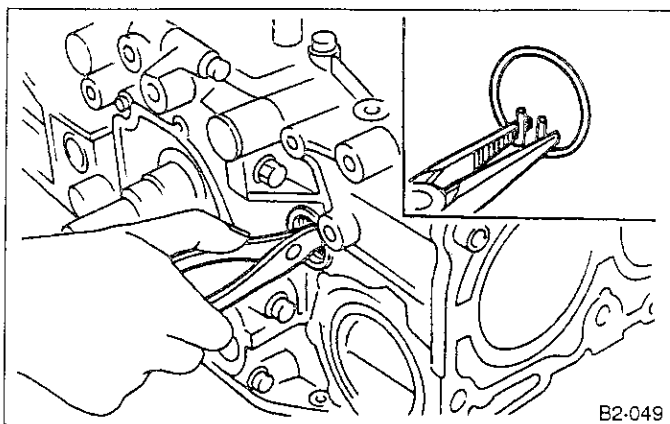
- 8) Remove oil strainer stay.
- 9) Remove oil strainer.
- 10) Remove baffle plate.
- 11) Remove oil filter.

B: DISASSEMBLY**1. PISTON PIN AND CYLINDER BLOCK CONNECTING BOLT**

B2-047

Fig. 73

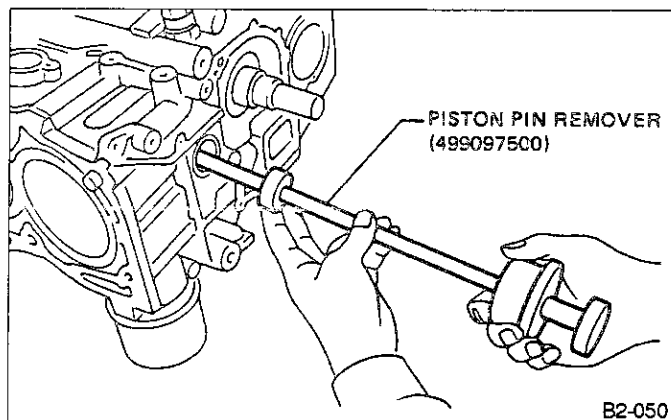
- 1) Remove service hole cover and service hole plugs using hexagon wrench (14 mm).
- 2) Rotate crankshaft to bring #1 and #2 pistons to BDC position, then remove piston circlip through service hole of #1 and #2 cylinders.



B2-049

Fig. 74

- 3) Draw out piston pin from #1 and #2 pistons.
Be careful not to confuse original combination of piston, piston pin and cylinder.



B2-050

Fig. 75

- 4) Similarly remove piston pins from #3 and #4 pistons.
- 5) Remove bolts which connect cylinder block on the side of #2 and #4 cylinders.
- 6) Back off bolts which connect cylinder block on the side of #1 and #3 cylinders two or three turns.

2. CYLINDER BLOCK

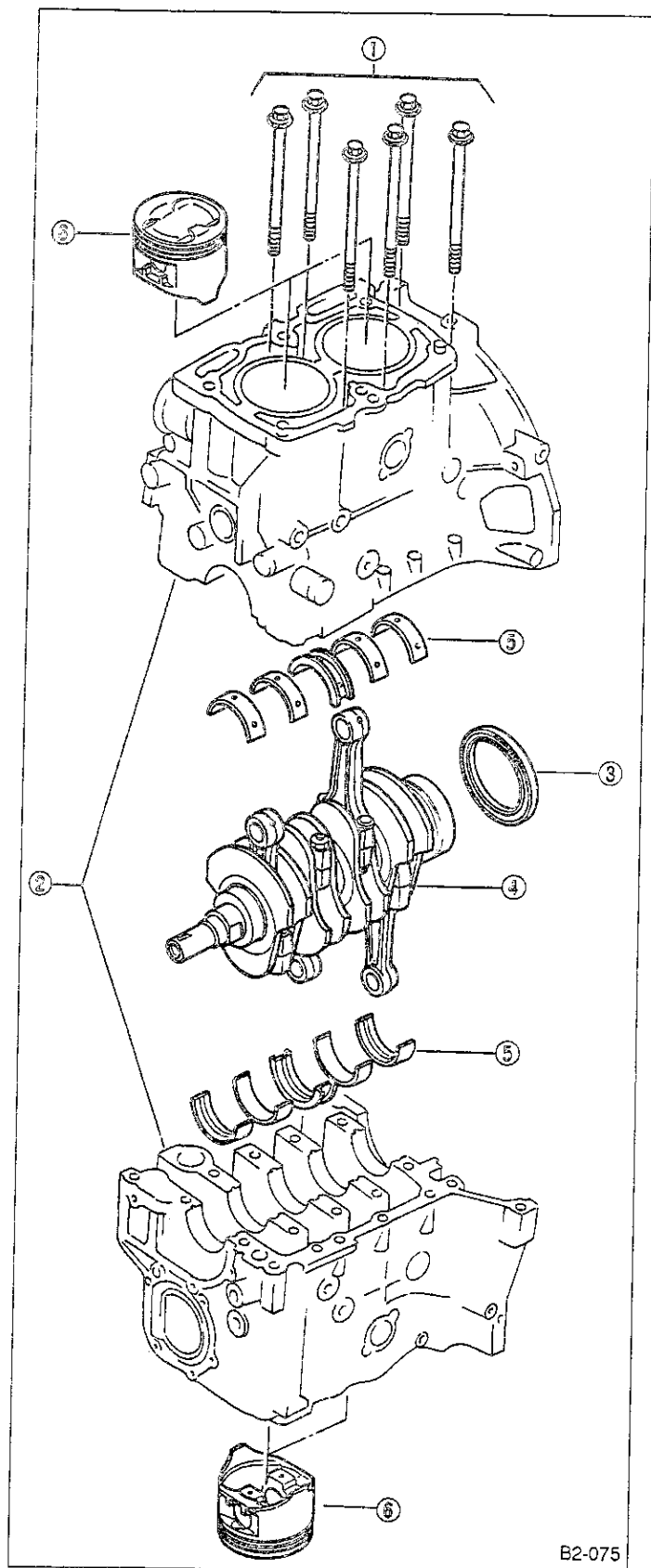


Fig. 76

1) Set up cylinder block so that #1 and #3 cylinders are on the upper side, then remove cylinder block connecting bolts.

2) Separate left-hand and right-hand cylinder blocks.

When separating cylinder block, do not allow the connecting rod to fall and damage the cylinder block.

3) Remove rear oil seal.

4) Remove crankshaft together with connecting rod.

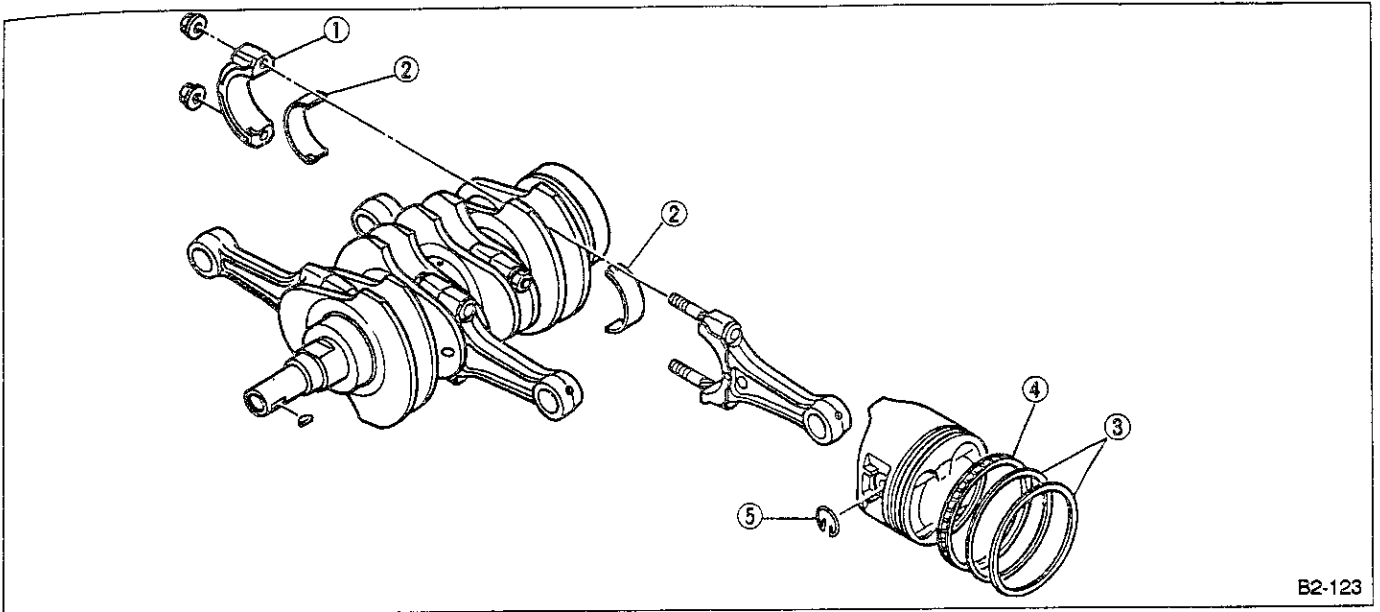
5) Remove crankshaft bearings from cylinder block by hand.

Do not confuse combination of crankshaft bearings. Press bearing at the end opposite to locking lip.

6) Draw out each piston from cylinder block using wooden bar or hammer handle.

Do not confuse combination of piston and cylinder.

3. CRANKSHAFT AND PISTON



B2-123

Fig. 77

- 1) Remove connecting rod cap.
 - 2) Remove connecting rod bearing.
- Arrange removed connecting rod, connecting rod cap and bearing in order to prevent confusion.
- 3) Remove the piston rings using the piston ring expander.
 - 4) Remove the oil ring by hand.
- Arrange the removed piston rings in good order to prevent confusion.
- 5) Remove circlip.

C: INSPECTION

1. CYLINDER BLOCK

- 1) Check for cracks and damage visually. Especially, inspect important parts by means of red check.
- 2) Check the oil passages for clogging.
- 3) Inspect crankcase surface that mates with cylinder head for warping by using a straight edge, and correct by grinding if necessary.

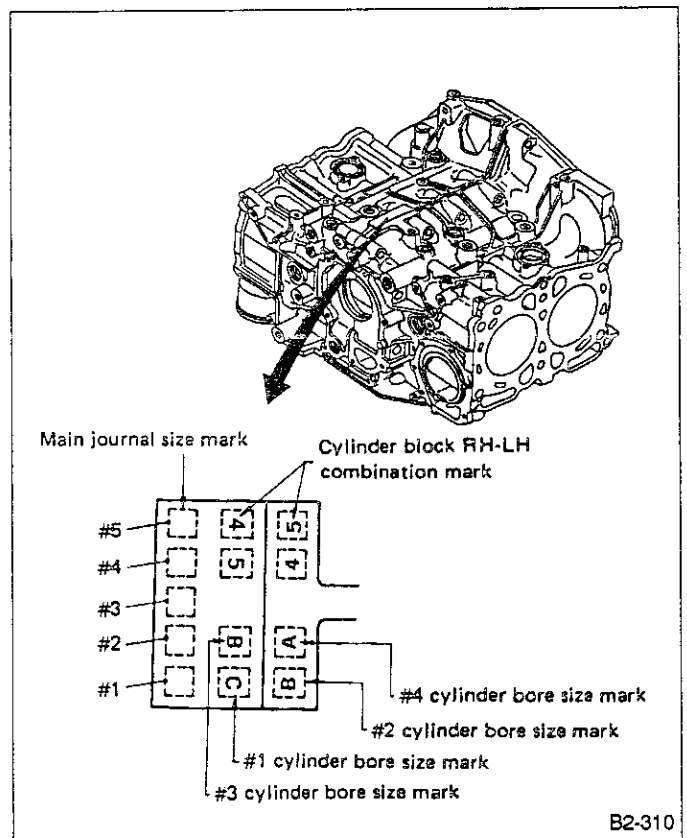
Warping limit:
0.05 mm (0.0020 in)

Grinding limit:
0.4 mm (0.016 in)

2. CYLINDER AND PISTON

- 1) The cylinder bore size is stamped on the cylinder block's front upper surface.

- (1) Standard sized pistons are classified into three grades, "A", "B" and "C". These grades should be used as a guideline in selecting a standard piston.
- (2) When piston is to be replaced due to general or cylinder wear, determine a suitable sized piston by measuring the piston clearance.



B2-310

Fig. 78

(3) Proper combination of pistons and cylinders

	Cylinder		Piston		Piston clearance 20°C (68° F)
	Bore size symbol	Cylinder bore dia.	Piston grade symbol	Standard piston dia.	
2200cc	A	96.905 — 96.915 mm (3.8151 — 3.8155 in)	A	96.885 — 96.895 mm (3.8144 — 3.8148 in)	0.01 — 0.03 mm (0.0004 — 0.0012 in)
	B	96.895 — 96.905 mm (3.8148 — 3.8151 in)	B	96.875 — 96.885 mm (3.8140 — 3.8144 in)	
	C	96.885 — 96.895 mm (3.8144 — 3.8148 in)	C	96.865 — 96.875 mm (3.8136 — 3.8140 in)	
2000cc	A	92.005 — 92.015 mm (3.6222 — 3.6226 in)	A	91.985 — 91.995 mm (3.6214 — 3.6218 in)	0.01 — 0.03 mm (0.0004 — 0.0012 in)
	B	91.995 — 92.005 mm (3.6218 — 3.6222 in)	B	91.975 — 91.985 mm (3.6211 — 3.6214 in)	
	C	91.985 — 91.995 mm (3.6214 — 3.6218 in)	C	91.965 — 91.975 mm (3.6207 — 3.6211 in)	
1800cc 1600cc	A	87.905 — 87.915 mm (3.4608 — 3.4612 in)	A	87.885 — 87.895 mm (3.4600 — 3.4604 in)	0.01 — 0.03 mm (0.0004 — 0.0012 in)
	B	87.895 — 87.905 mm (3.4604 — 3.4608 in)	B	87.875 — 87.885 mm (3.4596 — 3.4600 in)	
	C	87.885 — 87.895 mm (3.4600 — 3.4604 in)	C	87.865 — 87.875 mm (3.4592 — 3.4596 in)	

2) Measure the inner diameter of each cylinder in both the thrust and piston pin directions at the heights shown in the figure, using a cylinder bore gauge.

Measurement should be performed at a temperature 20°C (68°F).

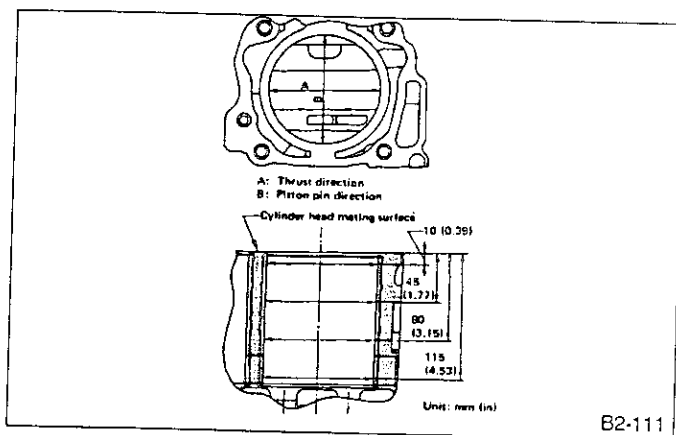


Fig. 79

B2-111

Taper:

Standard

0.015 mm (0.0006 in)

Limit

0.050 mm (0.0020 in)

Out-of-roundness:

Standard

0.010 mm (0.0004 in)

Limit

0.050 mm (0.0020 in)

Cylinder to piston clearance at 20°C (68°F):

Standard

0.010 — 0.030 mm (0.0004 — 0.0012 in)

Limit

0.060 mm (0.0024 in)

Standard diameter:

2200cc

A 96.905 — 96.915 mm
(3.8151 — 3.8155 in)B 96.895 — 96.905 mm
(3.8148 — 3.8151 in)C 96.885 — 96.895 mm
(3.8144 — 3.8148 in)

2000cc

A 92.005 — 92.015 mm
(3.6222 — 3.6226 in)B 91.995 — 92.005 mm
(3.6218 — 3.6222 in)C 91.985 — 91.995 mm
(3.6214 — 3.6218 in)

1800cc, 1600cc

A 87.905 — 87.915 mm
(3.4608 — 3.4612 in)B 87.895 — 87.905 mm
(3.4604 — 3.4608 in)C 87.885 — 87.895 mm
(3.4600 — 3.4604 in)

3) Boring and honing

(1) If the value of taper, out-of-roundness, or cylinder-to-piston clearance measured exceeds the specified limit or if there is any damage on the cylinder wall, rebores it to use an oversize piston.

When any of the cylinders needs reboring, all other cylinders must be bored at the same time, and use oversize pistons. Do not perform boring on one cylinder only, nor use an oversize piston for one cylinder only.

(2) Get four of the oversize pistons and measure the outer diameter of each piston at the height shown in the figure. (Thrust direction)

Measurement should be performed at a temperature of 20°C (68°F).

Piston outer diameter:

2200cc

Standard

A 96.885 — 96.895 mm (3.8144 — 3.8148 in)

B 96.875 — 96.885 mm (3.8140 — 3.8144 in)

C 96.865 — 96.875 mm (3.8136 — 3.8140 in)

0.25 mm (0.0098 in) oversize

97.125 — 97.135 mm (3.8238 — 3.8242 in)

0.50 mm (0.0197 in) oversize

97.375 — 97.385 mm (3.8337 — 3.8340 in)

2000cc

Standard

A 91.985 — 91.995 mm (3.6214 — 3.6218 in)

B 91.975 — 91.985 mm (3.6211 — 3.6214 in)

C 91.965 — 91.975 mm (3.6207 — 3.6211 in)

0.25 mm (0.0098 in) oversize

92.225 — 92.235 mm (3.6309 — 3.6313 in)

0.50 mm (0.0197 in) oversize

92.475 — 92.485 mm (3.6407 — 3.6411 in)

1800cc, 1600cc

Standard

A 87.885 — 87.895 mm (3.4600 — 3.4604 in)

B 87.875 — 87.885 mm (3.4596 — 3.4600 in)

C 87.865 — 87.875 mm (3.4592 — 3.4596 in)

0.25 mm (0.0098 in) oversize

88.125 — 88.135 mm (3.4695 — 3.4699 in)

0.50 mm (0.0197 in) oversize

88.375 — 88.385 mm (3.4793 — 3.4797 in)

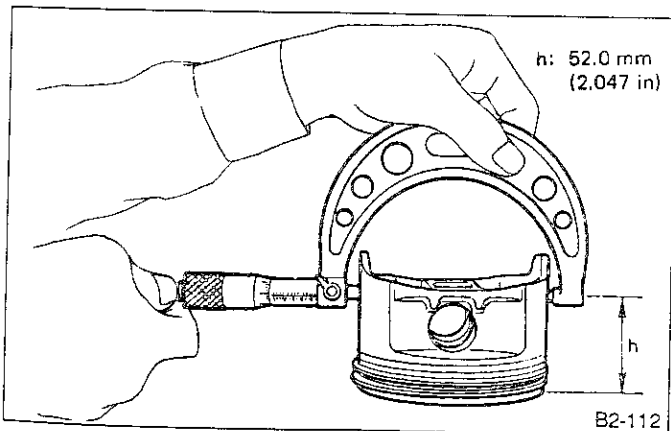


Fig. 80

(3) If the cylinder inner diameter exceeds the limit after boring and honing, replace the crankcase.

Immediately after reboring, the cylinder diameter may differ from its real diameter due to temperature rise. Thus, pay attention to this when measuring the cylinder diameter.

Limit of cylinder enlarging (boring):
0.3 mm (0.012 in)

3. PISTON AND PISTON PIN

1) Check pistons and piston pins for damage, cracks, and wear and the piston ring grooves for wear and damage. Replace if defective.

2) Measure the piston-to-cylinder clearance at each cylinder as instructed in CYLINDER AND PISTON. If any of the clearances is not to specification, replace the piston or bore the cylinder to use an oversize piston.

3) Make sure that piston pin can be inserted into the piston pin hole with a thumb at 20°C (68°F). Replace if defective.

Standard clearance between piston pin and hole in piston:

0.001 — 0.013 mm (0.00004 — 0.00051 in)

Standard clearance between piston pin and hole in connecting rod:

0 — 0.022 mm (0 — 0.0009 in)

4. PISTON RING

1) If piston ring is broken, damaged, or worn, or if its tension is insufficient, or when the piston is replaced, replace piston ring with a new one of the same size as the piston.

"R" or "N" is marked on the end of the top and second rings. When installing the rings to the piston, face this mark upward.

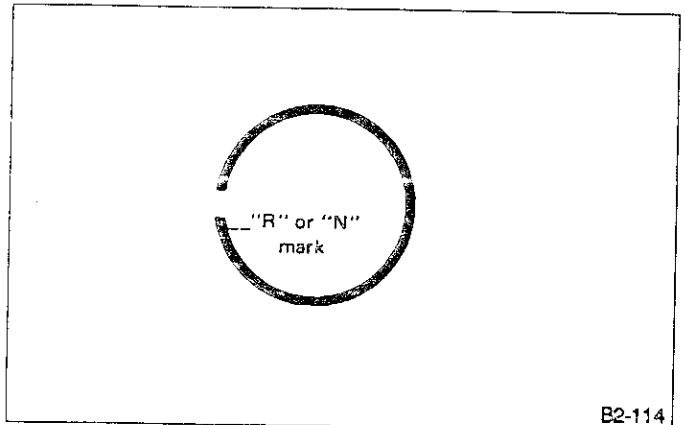


Fig. 81

The oil ring is a combined ring consisting of two rails and a spacer in between. When installing, be careful not to make misassembly.

Unit:mm (in)

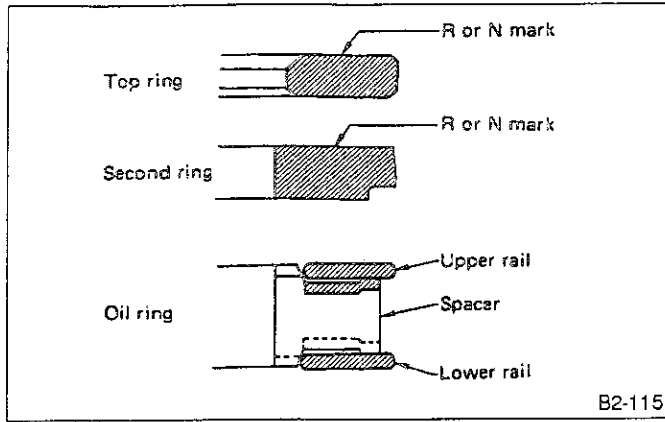


Fig. 82

2) Squarely place piston ring and oil ring in cylinder, and measure the piston ring gap with a thickness gauge.

Unit: mm (in)

		Standard	Limit
Piston ring gap	Top ring	0.20 — 0.35 (0.0079 — 0.0138)	1.0 (0.039)
	Second ring	0.20 — 0.35 (0.0079 — 0.0138)	1.0 (0.039)
	Oil ring rail	0.20 — 0.70 (0.0079 — 0.0276)	1.5 (0.059)

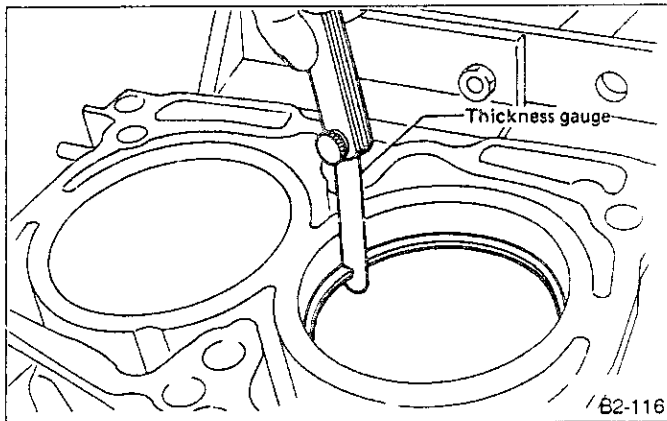


Fig. 83

3) Measure the clearance between piston ring and piston ring groove with a thickness gauge.

Before measuring the clearance, clean the piston ring groove and piston ring.

		Standard	Limit
Clearance between piston ring and piston ring groove	Top ring	0.04 — 0.08 (0.0016 — 0.0031)	0.15 (0.0059)
	Second ring	0.03 — 0.07 (0.0012 — 0.0028)	0.15 (0.0059)

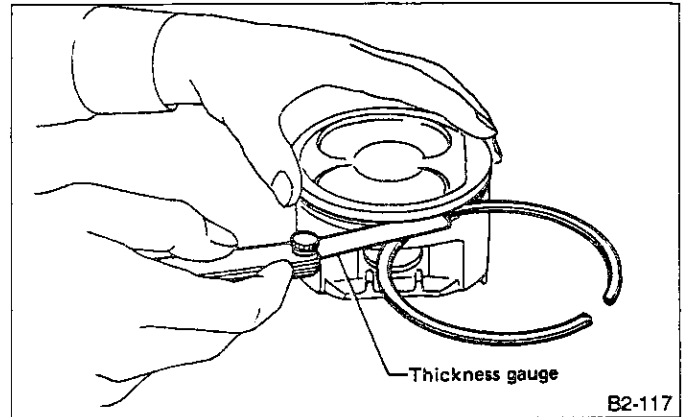


Fig. 84

5. CONNECTING ROD

- 1) Replace connecting rod, if the large or small end thrust surface is damaged.
- 2) Check for bend or twist using a connecting rod aligner. Replace connecting rod if the bend or twist exceeds the limit.

**Limit of bend or twist per 100 mm (3.94 in) in length:
0.10 mm (0.0039 in)**

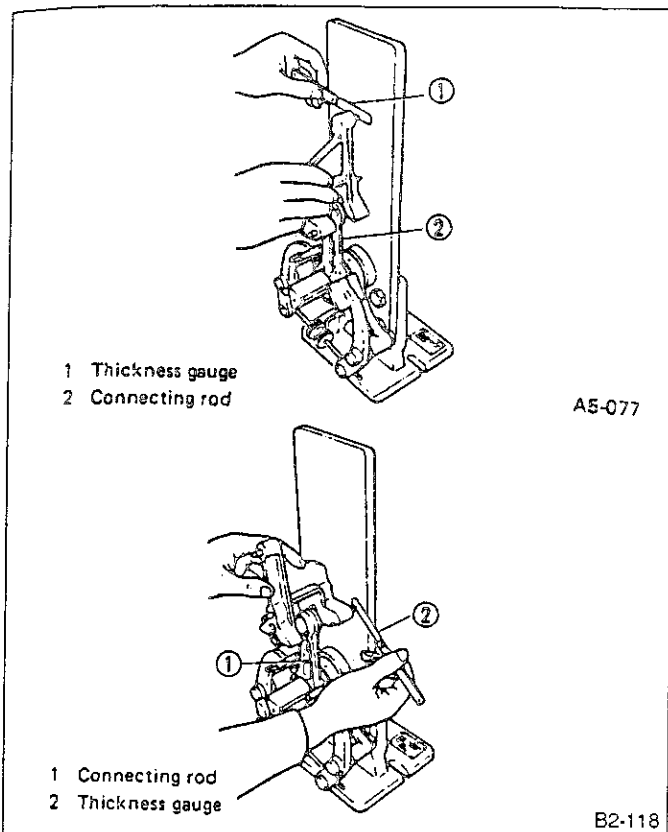


Fig. 85

3) Install connecting rod fitted with bearing to crankshaft and measure the side clearance (thrust clearance). Replace connecting rod if the side clearance exceeds the specified limit.

Connecting rod side clearance:

Standard

0.070 — 0.330 mm (0.0028 — 0.0130 in)

Limit

0.4 mm (0.016 in)

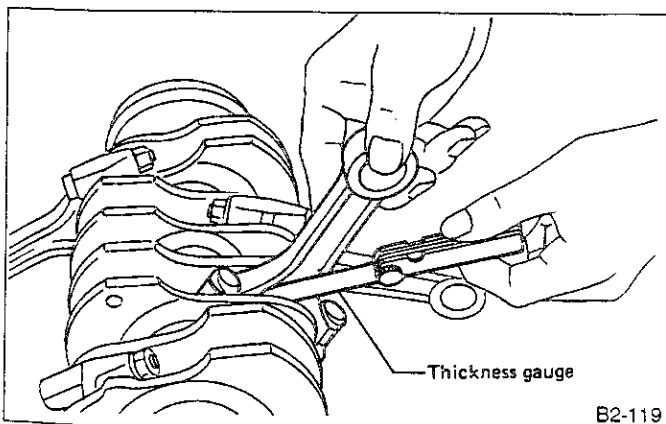


Fig. 86

4) Inspect connecting rod bearing for scar, peeling, seizure, melting, wear, etc.

5) Measure the oil clearance on individual connecting rod bearings by means of plastigauge. If any oil clearance is not within specification, replace the defective bearing with a new one of standard size or undersize as necessary, necessary. (See the table below.)

Connecting rod oil clearance:

Standard

0.015 — 0.045 mm (0.0006 — 0.0018 in)

Limit

0.05 mm (0.0020 in)

Unit: mm (in)

Bearing	Bearing size (Thickness at center)	Outer diameter of crank pin
Standard	1.492 — 1.501 (0.0587 — 0.0591)	51.984 — 52.000 (2.0466 — 2.0472)
0.03 undersize	1.510 — 1.513 (0.0594 — 0.0596)	51.954 — 51.970 (2.0454 — 2.0461)
0.05 undersize	1.520 — 1.523 (0.0598 — 0.0600)	51.934 — 51.950 (2.0446 — 2.0453)
0.25 Undersize	1.620 — 1.623 (0.0638 — 0.0639)	51.734 — 51.750 (2.0368 — 2.0374)

6) Inspect bushing at connecting rod small end, and replace if worn or damaged. Also measure the piston pin clearance at the connecting rod small end.

Clearance between piston pin and bushing:

Standard

0 — 0.022 mm (0 — 0.0009 in)

Limit

0.030 mm (0.0012 in)

Replacement procedure is as follows.

(1) Remove bushing from connecting rod with REMOVER & REPLACER and press.

(2) Press bushing with REMOVER & REPLACER after applying oil on the periphery of bushing.

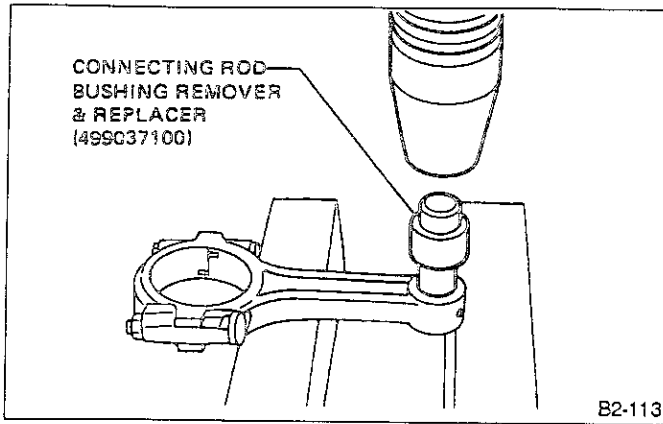


Fig. 87

(3) Make two 3 mm (0.12 in) holes in bushing. Ream the inside of bushing.

(4) After completion of reaming, clean bushing to remove chips.

6. CRANKSHAFT AND CRANKSHAFT BEARING

1) Clean crankshaft completely and check for cracks by means of red check etc., and replace if defective.

2) Measure the crankshaft bend, and correct or replace if it exceeds the limit.

If a suitable V-block is not available, install #1 and #5 crankshaft bearing on cylinder block, position crankshaft on these bearings and measure crankshaft bend using a dial gauge.

Crankshaft bend limit:
0.035 mm (0.0014 in)

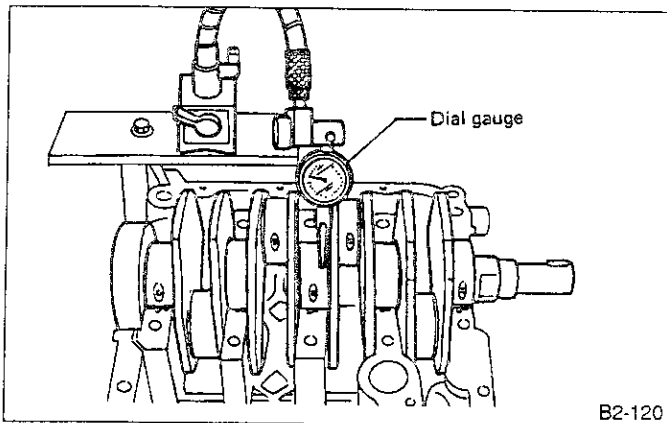


Fig. 88

3) Inspect the crank journal and crankpin for wear. If not to specifications, replace bearing with an undersize one, and replace or recondition crankshaft as necessary. When grinding crank journal or crankpin, finish them to the specified dimensions according to the undersize bearing to be used.

Crankpin and crank journal:

Out-of-roundness

0.03 mm (0.0012 in) or less

Taper limit

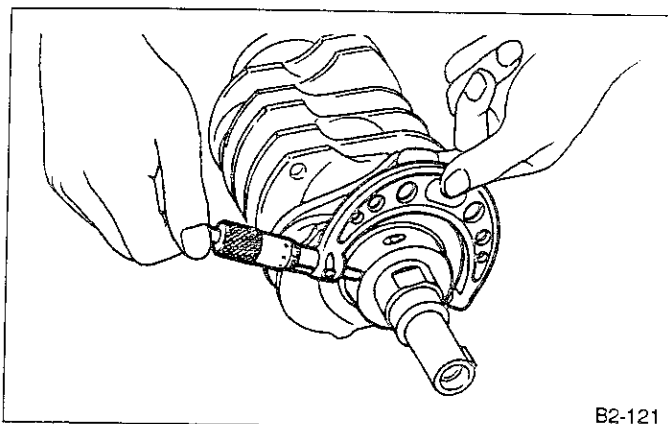
0.07 mm (0.0028 in)

Grinding limit

0.25 mm (0.0098 in)

Unit: mm (in)

		Crank journal			Crank pin O.D.
		#1, #5	#2, #4	#3	
Standard	Journal O.D.	59.984 — 60.000 (2.3616 — 2.3622)	59.984 — 60.000 (2.3616 — 2.3622)	59.984 — 60.000 (2.3616 — 2.3622)	51.984 — 52.000 (2.0466 — 2.0472)
	Bearing size (Thickness at center)	1.998 — 2.011 (0.0787 — 0.0792)	2.000 — 2.013 (0.0787 — 0.0793)	2.000 — 2.013 (0.0787 — 0.0793)	1.492 — 1.510 (0.0587 — 0.0594)
0.03 undersize	Journal O.D.	59.954 — 59.970 (2.3604 — 2.3610)	←	←	51.954 — 51.970 (2.0454 — 2.0461)
	Bearing size (Thickness at center)	2.017 — 2.020 (0.0794 — 0.0795)	2.019 — 2.022 (0.0795 — 0.0796)	2.019 — 2.022 (0.0795 — 0.0796)	1.510 — 1.513 (0.0594 — 0.0596)
0.05 undersize	Journal O.D.	59.934 — 59.950 (2.3596 — 2.3602)	←	←	51.934 — 51.950 (2.0446 — 2.0453)
	Bearing size (Thickness at center)	2.027 — 2.030 (0.0798 — 0.0799)	2.029 — 2.032 (0.0799 — 0.0800)	2.029 — 2.032 (0.0799 — 0.0800)	1.520 — 1.523 (0.0598 — 0.0600)
0.25 undersize	Journal O.D.	59.734 — 59.750 (2.3517 — 2.3524)	←	←	51.734 — 51.750 (2.0368 — 2.0374)
	Bearing size (Thickness at center)	2.127 — 2.130 (0.0837 — 0.0839)	2.129 — 2.132 (0.0838 — 0.0839)	2.129 — 2.132 (0.0838 — 0.0839)	1.620 — 1.623 (0.0638 — 0.0639)



B2-121

Fig. 89

4) Measure the thrust clearance of crankshaft at center bearing. If the clearance exceeds the limit, replace bearing.

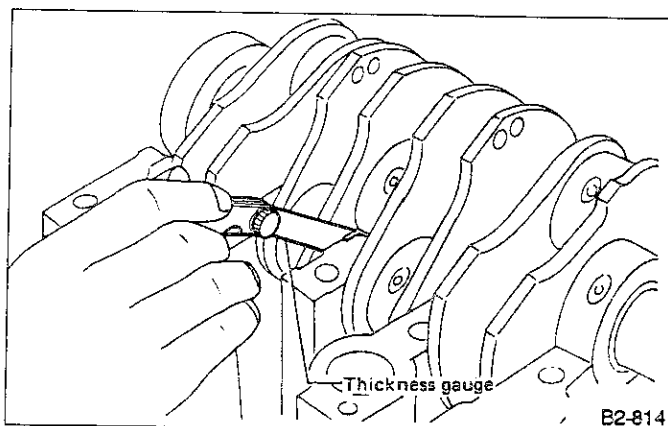
Crankshaft thrust clearance:

Standard

0.030 — 0.115 mm (0.0012 — 0.0045 in)

Limit

0.25 mm (0.0098 in)



B2-814

Fig. 90

5) Inspect individual crankshaft bearings for signs of flaking, seizure, melting, and wear.

6) Measure the oil clearance on each crankshaft bearing by means of plastigauge. If the measurement is not within the specification, replace defective bearing with an undersize one, and replace or recondition crankshaft as necessary.

Unit: mm (in)

Crankshaft oil clearance		
Standard	#1, #5	0.010 — 0.030 (0.0004 — 0.0012)
	#2, #3, #4	0.010 — 0.030 (0.0004 — 0.0012)
Limit	#1, #5	0.040 (0.0016)
	#2, #3, #4	0.035 (0.0014)

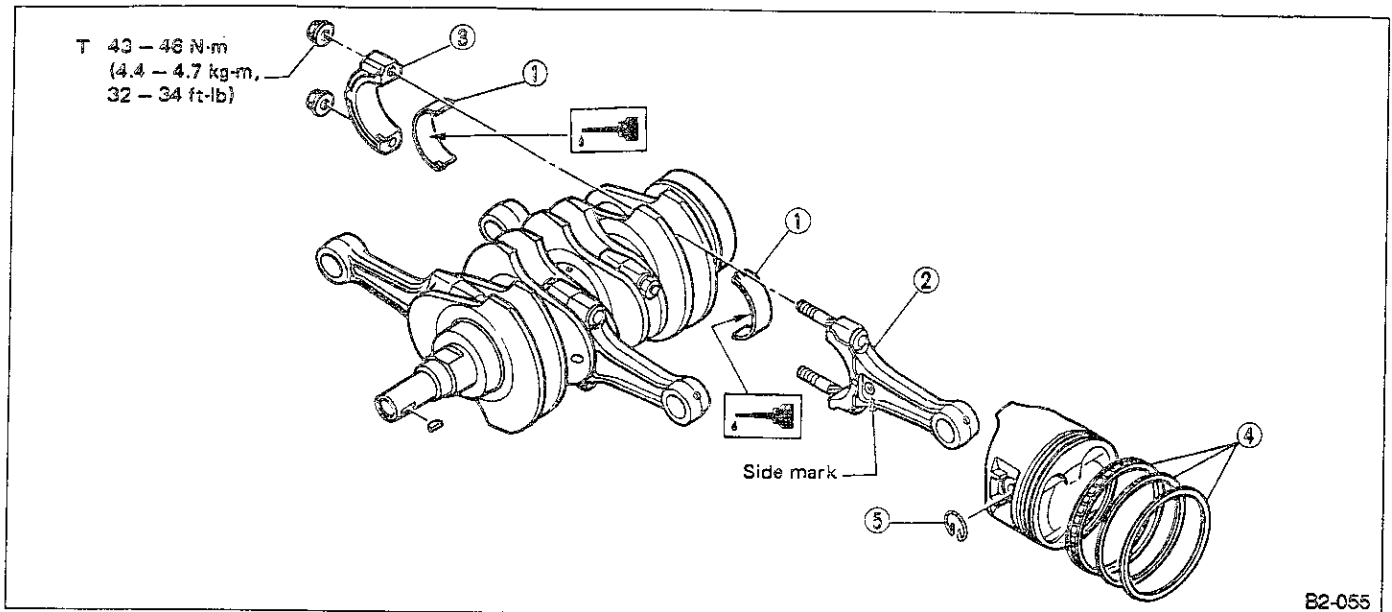
D: ASSEMBLY**1. CRANKSHAFT AND PISTON**

Fig. 91

1) Install connecting rod bearings on connecting rods and connecting rod caps.

Apply oil to the surfaces of the connecting rod bearings.

2) Install connecting rod on crankshaft.

Position each connecting rod with the side marked facing forward.

3) Install connecting rod cap with connecting rod nut. Ensure the arrow on connecting rod cap faces the front during installation.

a. Each connecting rod has its own mating cap. Make sure that they are assembled correctly by checking their matching number.

b. When tightening the connecting rod nuts, apply oil on the threads.

4) Installation of piston rings and oil ring.

(1) Install oil ring spacer, upper rail and lower rail in this order by hand. Then install second ring and top ring with a piston ring expander.

(2) Position the gaps of the piston rings and oil ring as shown in the figure.

5) Install circlip.

Install circlips in piston holes located opposite service holes in cylinder block, when positioning all pistons in the corresponding cylinders.

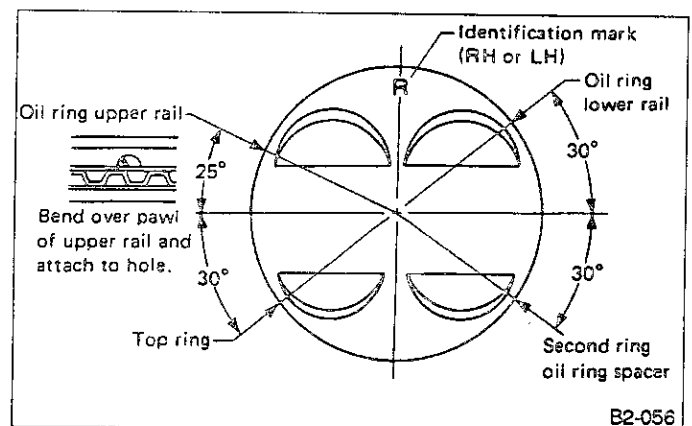


Fig. 92

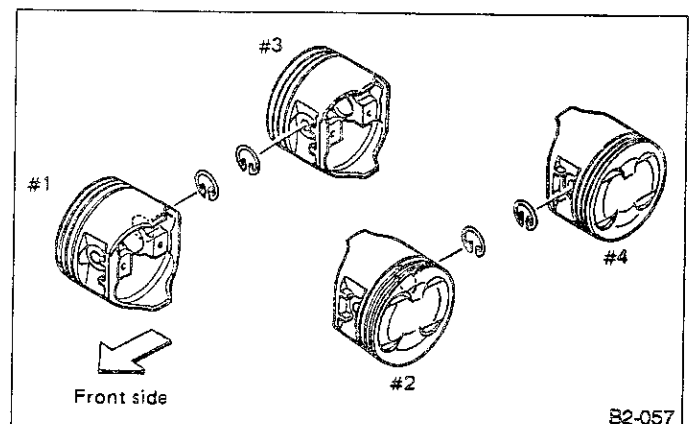


Fig. 93

2. CYLINDER BLOCK

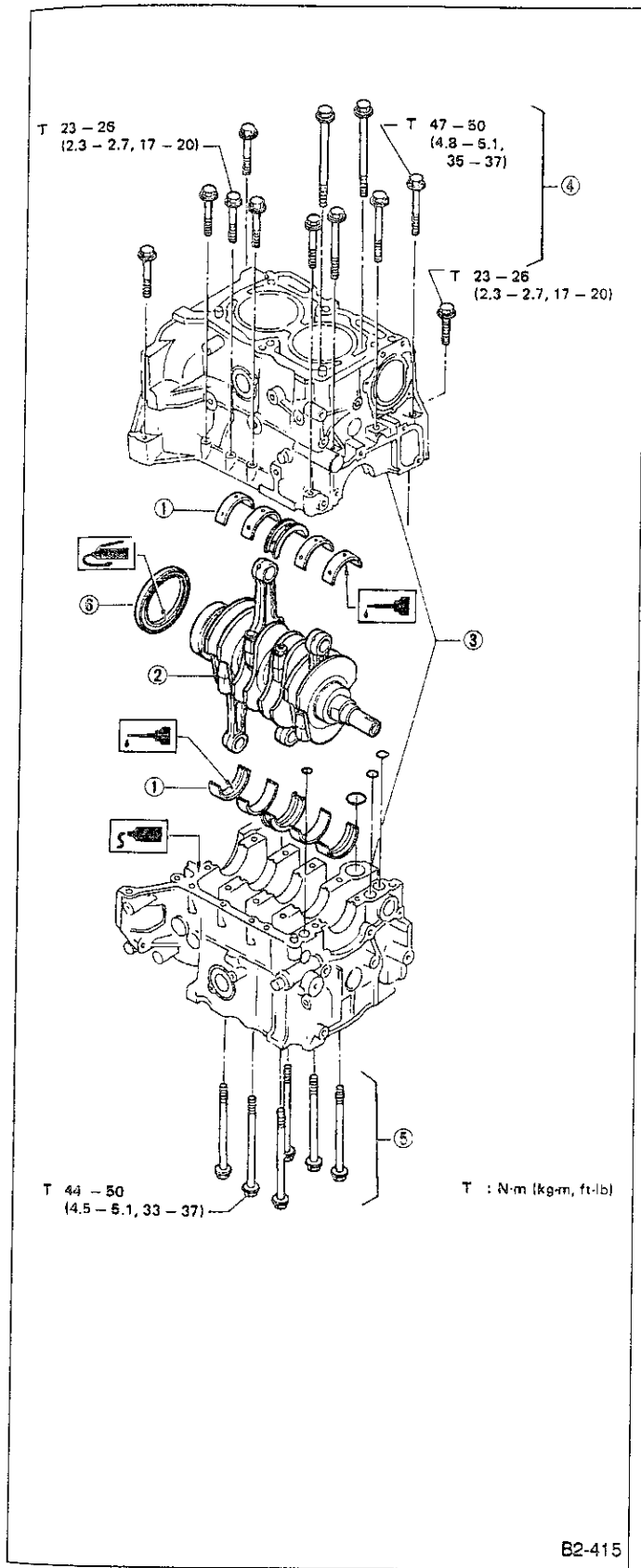


Fig. 94

1) Install ENGINE STAND to cylinder block, then install crankshaft bearings.

Remove oil the mating surface of bearing and cylinder block before installation. Also apply a coat of engine oil to crankshaft pins.

- 2) Position crankshaft on the #1 & #3 cylinder block.
- 3) Apply fluid packing to the mating surface of #1 & #3 cylinder block, and position the #2 & #4 cylinder block on #1 & #3 cylinder block.

Fluid packing:
Three-bond 1215 or equivalent

Do not allow fluid packing to jut into O-ring grooves, oil passages, bearing grooves, etc.

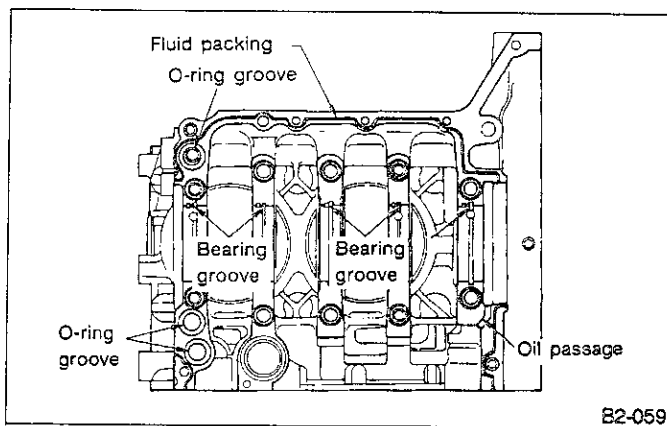


Fig. 95

- 4) Temporarily tighten #2 & #4 cylinder block side connecting bolts to 20 N·m (2 kg-m, 14 ft-lb).
- 5) Turn cylinder block so that it is horizontal. Tighten all cylinder block connecting bolts to specified torque, starting with bolts on the #1 & #3 cylinder block side.
- 6) Install rear oil seal.

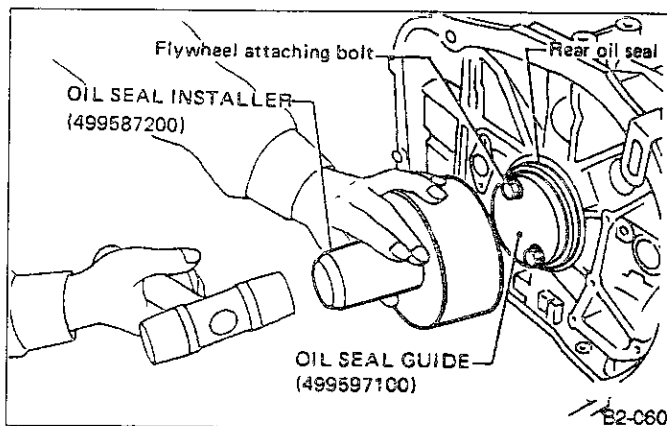


Fig. 96

3. PISTON AND PISTON PIN (#1 and #2)

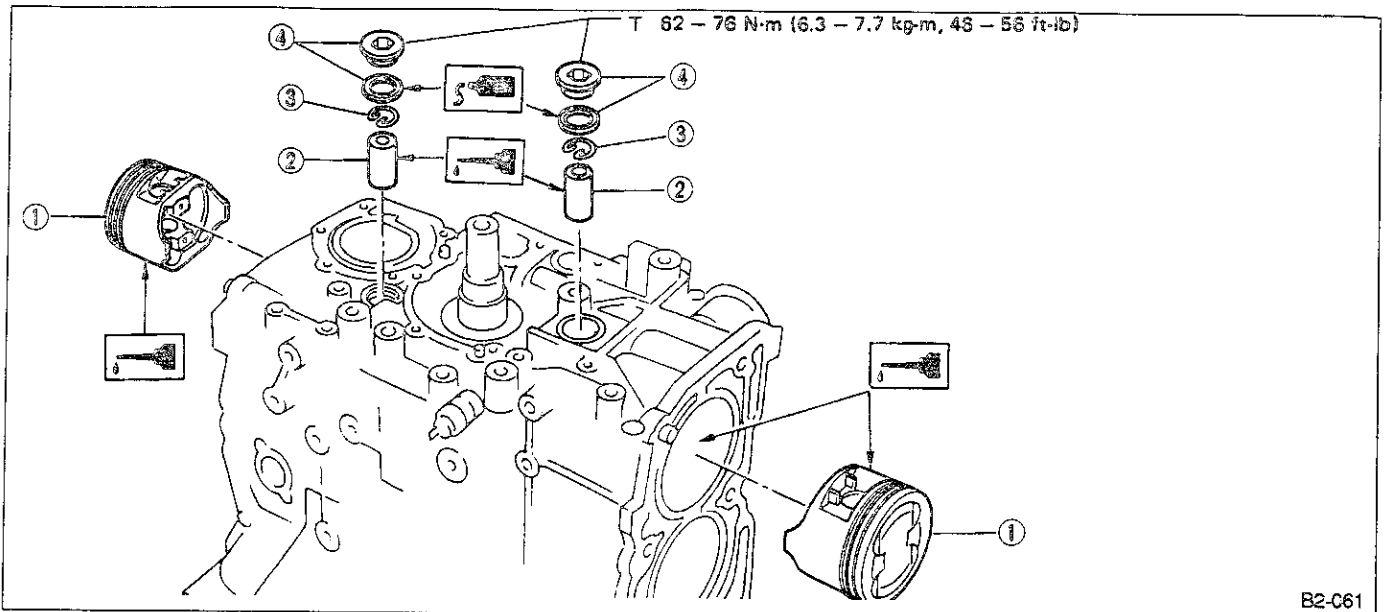


Fig. 97

1) Installing piston

- (1) Turn cylinder block so that #1 and #2 cylinders face upward.
- (2) Turn crankshaft so that #1 and #2 connecting rods are set at bottom dead center.
- (3) Apply a coat of engine oil to pistons and cylinders and insert pistons in their cylinders.

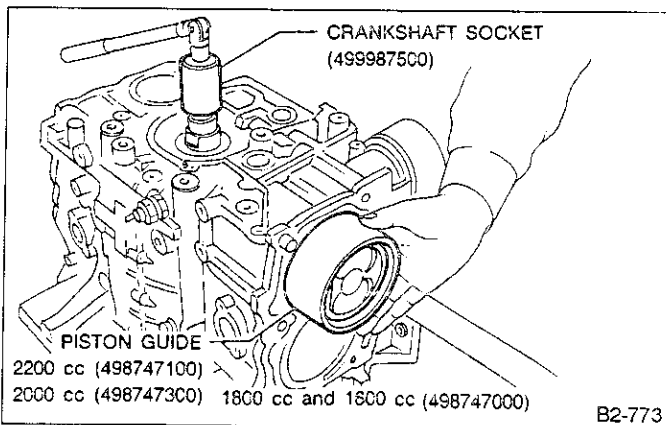


Fig. 98

2) Installing piston pin

- (1) Insert the PISTON PIN GUIDE into service hole to align piston pin hole with connecting rod small end. Apply a coat of engine oil to PISTON PIN GUIDE before insertion.

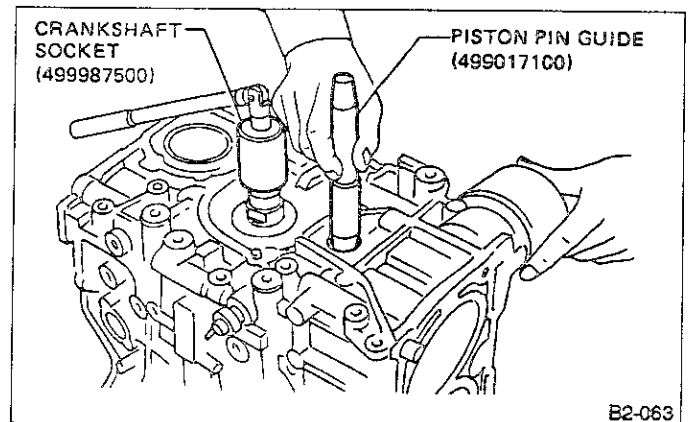


Fig. 99

- (2) Apply a coat of engine oil to piston pin and insert piston pin into piston and connecting rod through service hole.
- (3) Install circlip.

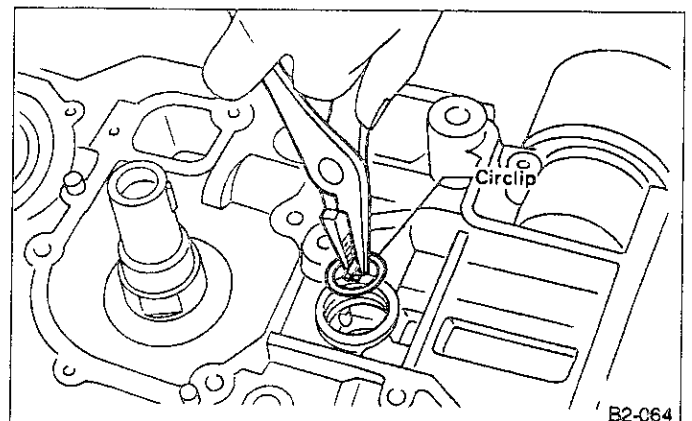


Fig. 100

(4) Install service hole plug and gasket.

Use a new gasket and apply a coat of fluid packing to it before installation.

Fluid packing:

Three-bond 1105

4. PISTON AND PISTON PIN (#3 and #4)

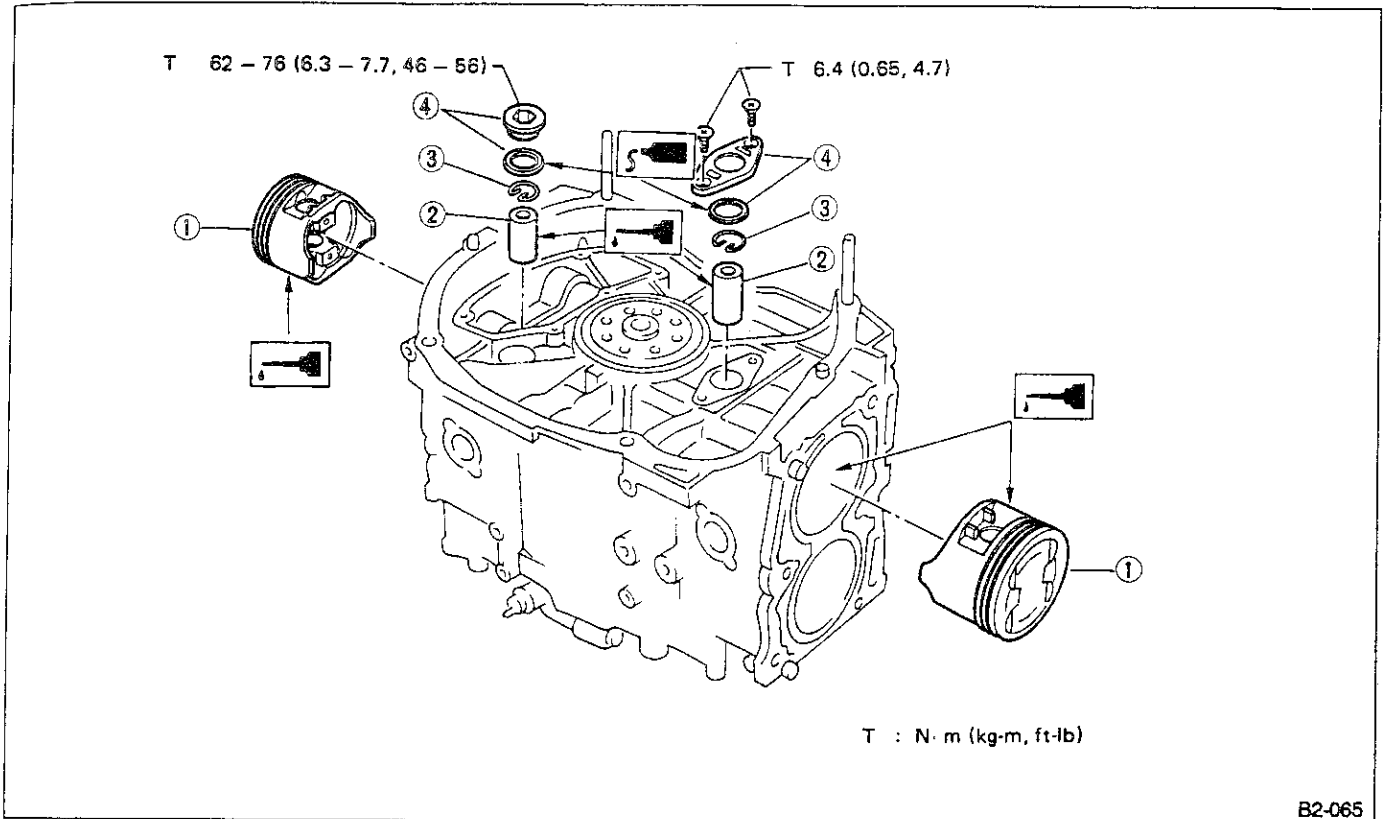
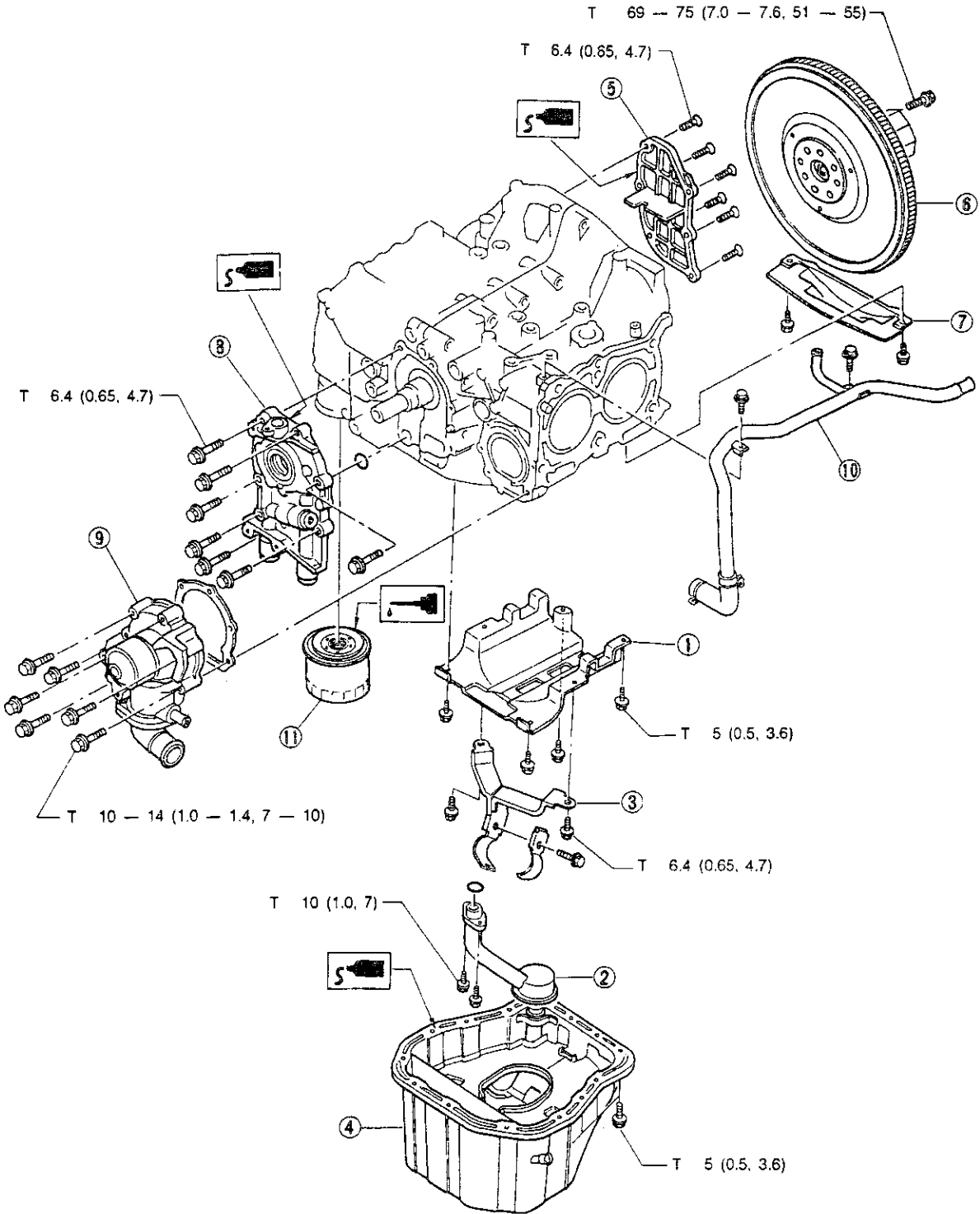


Fig. 101

Turn cylinder block so that #3 and #4 cylinders face upward. Using the same procedures as used for #1 and #2 cylinders, install pistons and piston pins.

E: INSTALLATION

1. OIL PUMP AND WATER PUMP



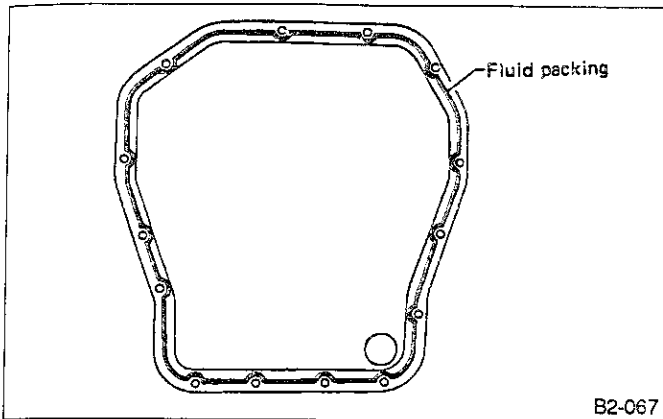
T : N·m (kg-m, ft-lb)

Fig. 102

- 1) Install baffle plate.
- 2) Install oil strainer and O-ring
- 3) Install oil strainer stay.
- 4) Apply fluid packing to matching surfaces and install oil pan.

Fluid packing:

Three-bond 1207C or equivalent



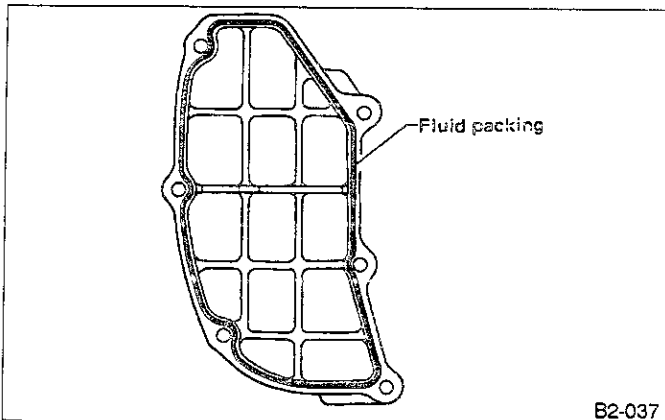
B2-067

Fig. 103

- 5) Apply fluid packing to matching surfaces and install oil separator cover.

Fluid packing:

Three-bond 1215 or equivalent

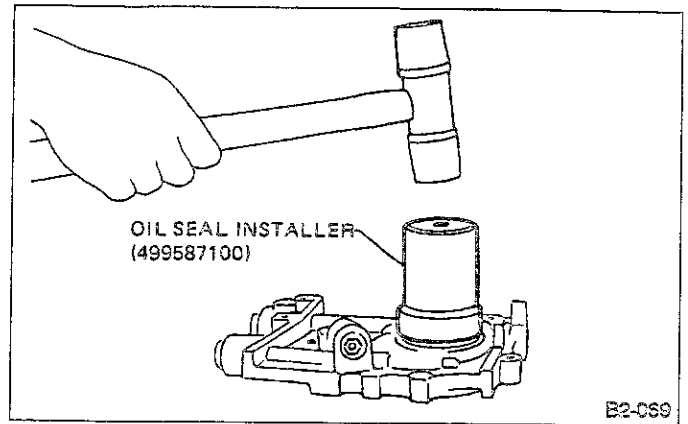


B2-037

Fig. 104

- 6) Install flywheel or drive plate.
- 7) Install housing cover.
- 8) Installation of oil pump

(1) Discard front oil seal after removal. Replace with a new one.



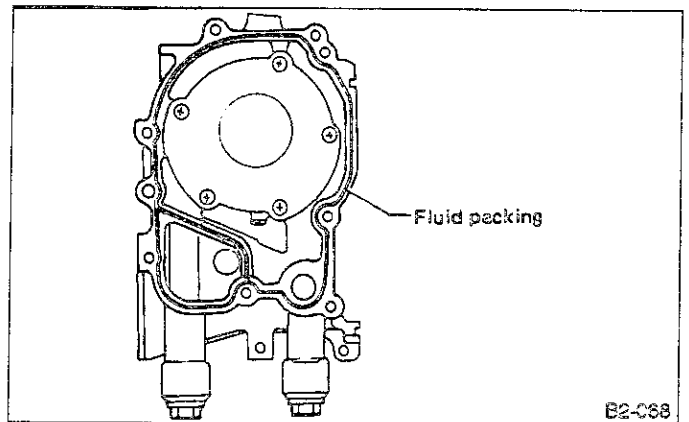
B2-069

Fig. 105

- (2) Apply fluid packing to matching surface of oil pump.

Fluid packing:

Three-bond 1215 or equivalent



B2-068

Fig. 106

- (3) Install oil pump on cylinder block. Be careful not to damage oil seal during installation.

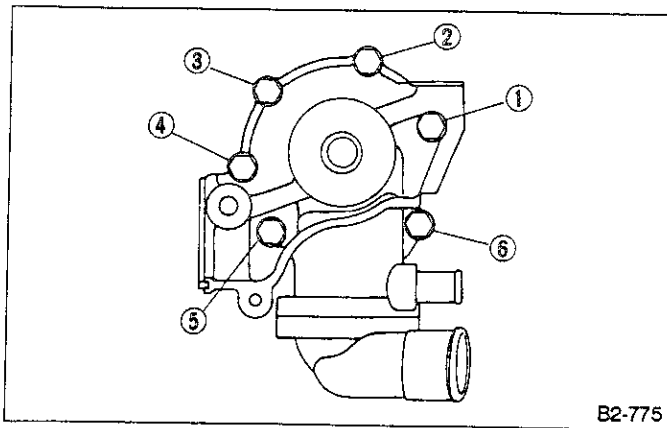
a. Do not forget to install O-ring and seal when installing oil pump.

b. Align flat surface of oil pump's inner rotor with crankshaft before installation.

- 9) Install water pump and gasket.

a. Be sure to use a new gasket.

b. When installing water pump, tighten bolts in two stages, in the numerical sequence shown in figure.



B2-775

Fig. 107

- 10) Install water pipe.
- 11) Install oil filter.

2. RELATED PARTS

- 1) Install cylinder head and intake manifold.
(Ref. to 5. Cylinder Head [W5E0].)
- 2) Install timing belt, camshaft sprocket and related parts.
(Ref. to 2. Timing Belt [W2C0].)

T TROUBLESHOOTING

1. Engine Trouble in General

Symbols shown in the chart refer to the possibility of reason for the trouble in order ("Very often" to "Rarely")													No.	TROUBLE	
○— Very often ◉— Sometimes △— Rarely													1	Engine will not start.	Starter does not turn.
													2		Initial combustion does not occur.
													3		Initial combustion occurs.
													4		Engine stalls after initial combustion.
													5	Rough idle and engine stall.	
													6	Low output, hesitation and poor acceleration.	
													7	Surging.	
													8	Engine does not return to idle.	
													9	Dieseling (Run-on).	
													10	Afterburning in exhaust system.	
													11	Knocking.	
													12	Excessive engine oil consumption.	
													13	Excessive fuel consumption.	
TROUBLE No.													POSSIBLE CAUSE		
1	2	3	4	5	6	7	8	9	10	11	12	13			
													STARTER		
○													● Defective battery-to-starter harness.		
△													● Defective starter switch.		
△													● Defective inhibitor switch.		
○	△												● Defective starter.		
													BATTERY		
◉													● Poor terminal connection.		
◉													● Run-down battery.		
○													● Defective charging system.		
	◉	◉	◉	◉	◉	◉	◉	◉	◉	◉		◉	MPFI SYSTEM (See Chap. 2-7.)		
													IGNITION SYSTEM		
	○	○	○	◉	◉	◉	◉	◉	◉	◉		◉	● Incorrect ignition timing.		
	○	◉		○	○	○			△			△	● Disconnection of spark plug cord.		
	○			△	◉	○	○		◉	○			● Defective distributor.		
	○			△	○	○							● Defective ignition coil.		
	○			△	△	△							● Defective cord or wiring.		
	○	○		△	○	△				○			● Leakage of spark plug cord.		
		○		○	○	○			◉				● Defective spark plug.		
	○	○	○	◉	○	◉	△		○	○			● Incorrect cam timing.		
1	2	3	4	5	6	7	8	9	10	11	12	13			

TROUBLE No.													POSSIBLE CAUSE	
1	2	3	4	5	6	7	8	9	10	11	12	13		
														INTAKE SYSTEM
		○	○	⊙	○	○	⊙	○	○				⊙	● Improper idle adjustment.
			○	⊙	⊙	⊙			△	⊙				● Loosened or cracked intake boot.
			○	⊙	⊙	⊙			△	⊙				● Loosened or cracked intake duct.
			△	⊙	⊙	⊙			△	⊙	⊙			● Loosened or cracked blow-by hose.
			△	⊙	○	⊙	⊙		○	⊙				● Loosened or cracked vacuum hose.
			△	○	○	○				⊙				● Defective air cleaner gasket.
		○	○	○	○	○				⊙				● Defective intake manifold gasket.
		○	○	○	○	○				⊙				● Defective throttle body gasket.
				△	○	○			○	○	○			● Defective PCV valve.
				○	○	○			△	○	△			● Loosened oil filler cap.
			△	△	⊙	○				○			⊙	● Dirty air cleaner element.
														FUEL LINE
	⊙	△		△	○	○								● Defective fuel pump.
		△	△	△	○	○								● Clogged fuel line.
	○	○	○	○	△	△								● Lack of or insufficient fuel.
														BELT
	○	○	○											● Defective.
	○	○	○	△	○	○			○	○			○	● Defective timing.
														FRICION
△														● Seizure of crankshaft and connecting-rod bearing.
△														● Seized camshaft.
△														● Seized or stuck piston and cylinder.
														COMPRESSION
	△	△	△	○	○	○			○	△			○	● Incorrect valve clearance.
	△	△	△	○	○	△			△				△	● Loosened spark plugs or defective gasket.
	△	△	△	○	○	△			△				△	● Loosened cylinder head nuts or defective gasket.
	△	△	△	○	○	△			○				○	● Improper valve seating.
	△	△	△	△	△	△			△		⊙		△	● Defective valve stem.
	○	○	○	○	○	△			△				△	● Worn or broken valve spring.
	△	△	△	○	△	△			△		⊙		○	● Worn or stuck piston rings, cylinder and piston.
	○	○	○	⊙	⊙	⊙			⊙	○			○	● Incorrect valve timing.
	○	○	○	○	○	○								● Improper engine oil (low viscosity).
1	2	3	4	5	6	7	8	9	10	11	12	13		

TROUBLE No.													POSSIBLE CAUSE	
1	2	3	4	5	6	7	8	9	10	11	12	13		
														LUBRICATION SYSTEM
				○	○				△				△	● Incorrect oil pressure.
											○			● Loosened oil pump attaching bolts and defective gasket.
											○			● Defective oil filter seal.
											○			● Defective crankshaft oil seal.
				△							○			● Defective rocker cover gasket.
											○			● Loosened oil drain plug or defective gasket.
											○			● Loosened oil pan fitting bolts or defective oil pan.
														COOLING SYSTEM
				△	△	○		○		⊙				● Overheating.
					△				△				△	● Over cooling.
														OTHERS
				⊙	⊙	△			△					● Malfunction of Evaporative Emission Control System. (See Chap. 2-1.)
				○			⊙							● Stuck or damaged throttle valve.
				△			○	○					○	● Accelerator cable out of adjustment.
1	2	3	4	5	6	7	8	9	10	11	12	13		

2. Engine Noise

Valve lash adjusters may make clicking noise once engine starts. It is normal if clicking noise ceases after a few minutes.

If clicking noise continues after a few minutes, check engine oil level and add oil if necessary. Warm up engine, then drive car at approximately 3,000 rpm for twenty minutes. If noise still exists, conduct troubleshooting procedures in accordance with the following table.

Type of sound	Condition	Possible cause
Regular clicking sound.	Sound increases as engine speed increases.	Valve mechanism is defective <ul style="list-style-type: none"> ● Broken lash adjuster. ● Worn valve rocker. ● Worn camshaft. ● Broken valve spring.
Heavy and dull metallic knock.	Oil pressure is low.	<ul style="list-style-type: none"> ● Worn crankshaft main bearing. ● Worn connecting rod bearing (big end).
	Oil pressure is normal.	<ul style="list-style-type: none"> ● Loose flywheel mounting bolts. ● Damaged engine mounting.
High-pitched metallic knock. (Engine knocking)	Sound is noticeable when accelerating with an overload.	<ul style="list-style-type: none"> ● Ignition timing advanced. ● Accumulation of carbon inside combustion chamber. ● Wrong spark plug. ● Improper gasoline.
Metallic knock when engine speed is medium (1,000 to 2,000 rpm).	Sound is reduced when* spark plug in noisy cylinder is shortened out.	<ul style="list-style-type: none"> ● Worn crankshaft main bearing. ● Worn bearing at crankshaft end of connecting rod.
Knocking sound when engine is operating under idling speed and engine is warm.	Sound is reduced when* spark plug in noisy cylinder is shortened out.	<ul style="list-style-type: none"> ● Worn cylinder liner and piston ring. ● Broken or stuck piston ring. ● Worn piston pin and hole at piston end of connecting rod.
	Sound is not reduced if each* spark plug is shortened out in turn.	<ul style="list-style-type: none"> ● Worn camshaft journal bore.
Squeaky sound.	—	<ul style="list-style-type: none"> ● Insufficient alternator lubrication.
Rubbing sound.	—	<ul style="list-style-type: none"> ● Defective alternator brush and rotor contact.

Type of sound	Condition	Possible cause
Gear scream when starting engine.	—	<ul style="list-style-type: none"> ● Defective ignition starter switch. ● Worn gear and starter pinion.
Sound like polishing glass with a dry cloth.	—	<ul style="list-style-type: none"> ● Loose drive belt. ● Defective water pump shaft.
Hissing sound.	—	<ul style="list-style-type: none"> ● Loss of compression. ● Air leakage in air intake system, hoses, connections or manifolds.
Timing belt noise.	—	<ul style="list-style-type: none"> ● Loose timing belt. ● Belt contacting case/adjacent part.

*: in 2200cc and 2000cc MPFI model, disconnect fuel injector connector at noisy cylinder.

SUBARU.

1992

**SERVICE
MANUAL**

	Page
M MECHANISM AND FUNCTION	2
1. General	2
2. Timing Belt	3
3. Belt Tension Adjuster	3
4. Belt Cover	4
5. Hydraulic Lash Adjuster	5
6. Camshaft	6
7. Cylinder Head	7
8. Cylinder Block	7
9. Crankshaft	8
10. Piston	8
S SPECIFICATIONS AND SERVICE DATA	9
A: SPECIFICATIONS	9
B: SERVICE DATA	10
C COMPONENT PARTS	13
1. Timing Belt	13
2. Cylinder Head and Camshaft	14
3. Cylinder Head and Valve ASSY	15
4. Cylinder Block	16
5. Crankshaft and Piston	17
W SERVICE PROCEDURE	18
1. General Precautions	18
2. Timing Belt	18
3. Camshaft	30
4. Cylinder Head	36
5. Cylinder Block	44
T TROUBLESHOOTING	63
1. Engine Trouble in General	63
2. Engine Noise	66



M MECHANISM AND FUNCTION

1. General

The engine is made from aluminum alloy and is horizontally opposed. It is a 4-stroke cycle, water-cooled, DOHC 16-valve, turbocharged engine.

A summary of the major construction and function features is as follows:

- The cylinder head is a center-plug type that utilizes pentroof combustion chambers. The four-valve design is provided with two intake valves and two exhaust valves per cylinder. The intake and exhaust ports are arranged in a cross-flow design.

- The pivot body of the valve rocker arm has a built-in hydraulic lash adjuster which eliminates the need for valve clearance adjustment.
- A single timing belt drives four camshafts on the left and right banks and the water pump on the left bank. Belt tension is automatically adjusted to eliminate maintenance.
- The crankshaft is supported by five bearings to provide high rigidity and strength.
- The cylinder block is made from aluminum diecast which is integrated with cast-iron cylinder liners.

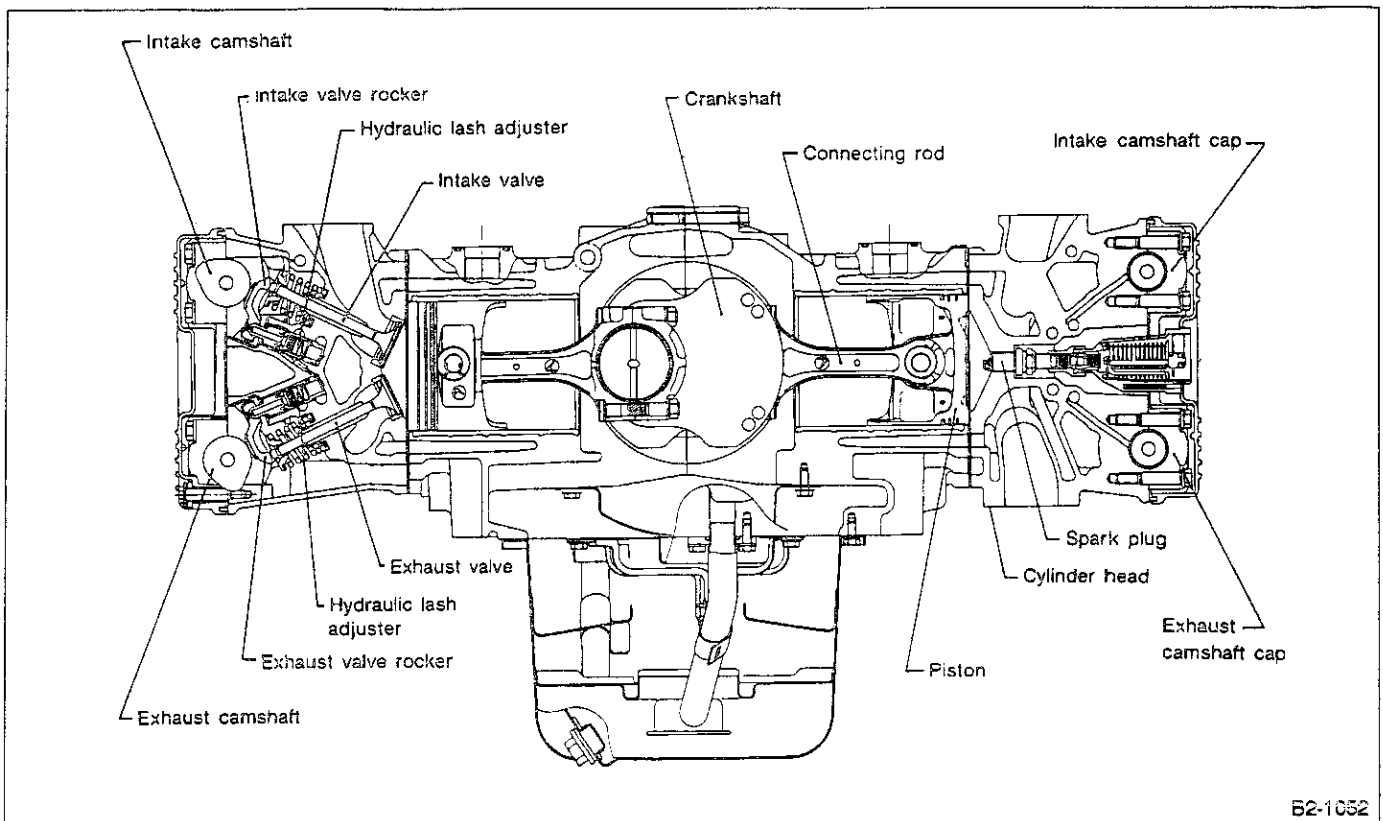


Fig. 1

2. Timing Belt

A single timing belt drives four camshafts (intake and exhaust camshafts on each bank). The back of the belt also drives the water pump.

The timing belt teeth have a specially designed round profile to provide quiet operation. The timing belt is

composed of a strong and inflexible core wire, a wear-resistant canvas and heat-resistant rubber material.

A hydraulic belt-tension adjuster constantly maintains specified belt tension to properly drive the camshafts, as well as to provide a "maintenance-free" advantage.

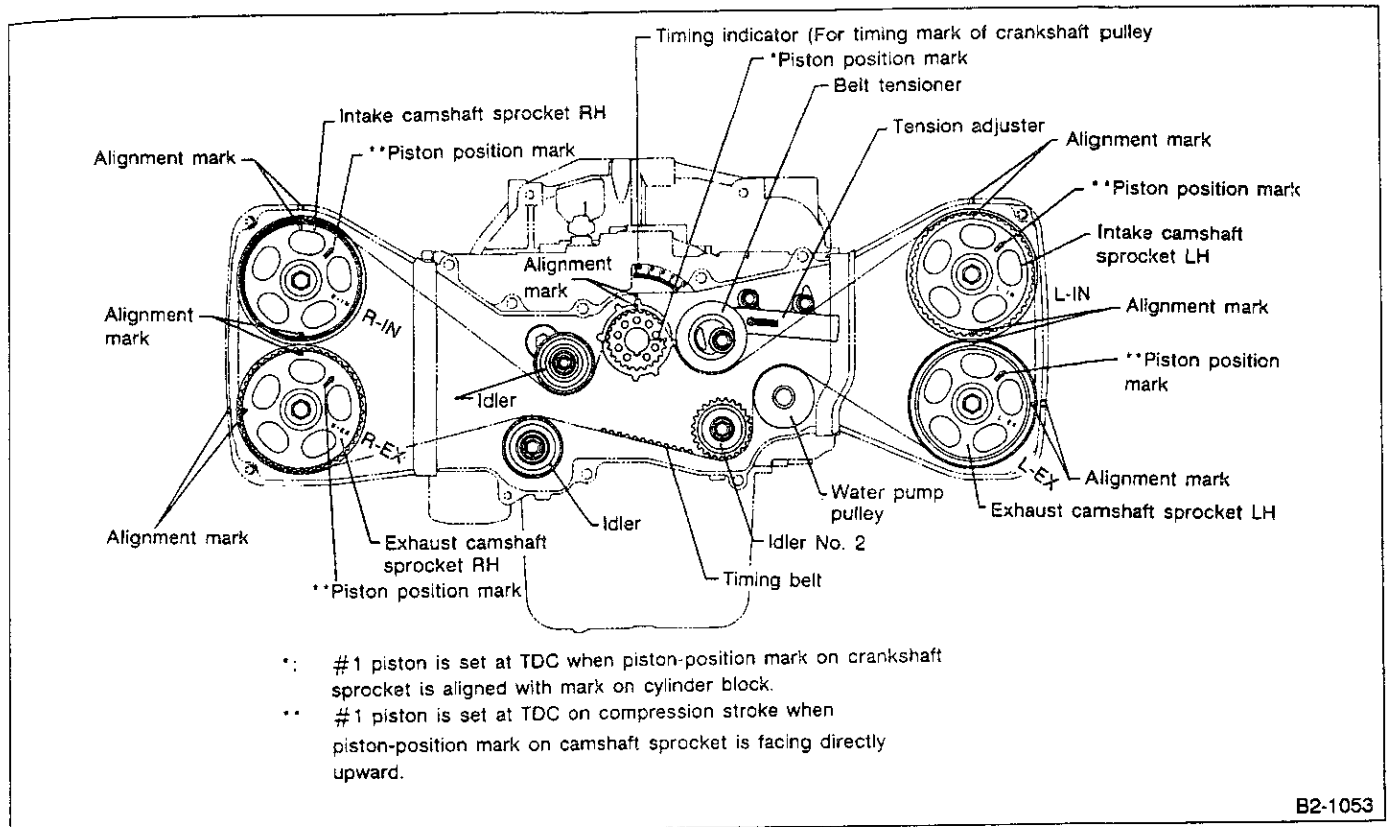


Fig. 2

3. Belt Tension Adjuster

The belt tension adjuster provides a constant value of tension for the timing belt. Proper belt tension is maintained using a rod to push the tension pulley. The location of the tensioner pulley shaft center is offset in relation to the center of the pulley's outside diameter.

The tensioner adjuster rod provides a rotary movement for the tensioner pulley by both tension of the spring housed in the adjuster.

1) Belt tension action

The tensioner adjuster rod is moved to the left by the force of the main spring. This causes silicon oil (which is held to constant pressure by compression-spring tension inside the reservoir chamber) to push the check ball so that silicon oil flows into the oil-pressure chamber.

The momentum which forces the adjuster rod out acts upon the tensioner arm so that the pulley is turned counterclockwise. Thus, timing belt tension is properly maintained.

2) Balance to belt tension

When the timing belt reaction force is balanced by the main spring tension (to push the adjuster rod), the arm is held stationary to maintain constant belt tension.

When the timing belt reaction force increases to such an extent that the belt will be too tight, a small quantity of oil in the oil-pressure chamber gradually returns to the reservoir chamber via the adjuster body-to-rod clearance. This return of oil continually moves the rod until the reaction force of the timing belt balances with main spring force and oil pressure inside the oil-pressure chamber. Thus, belt tension is constantly maintained.

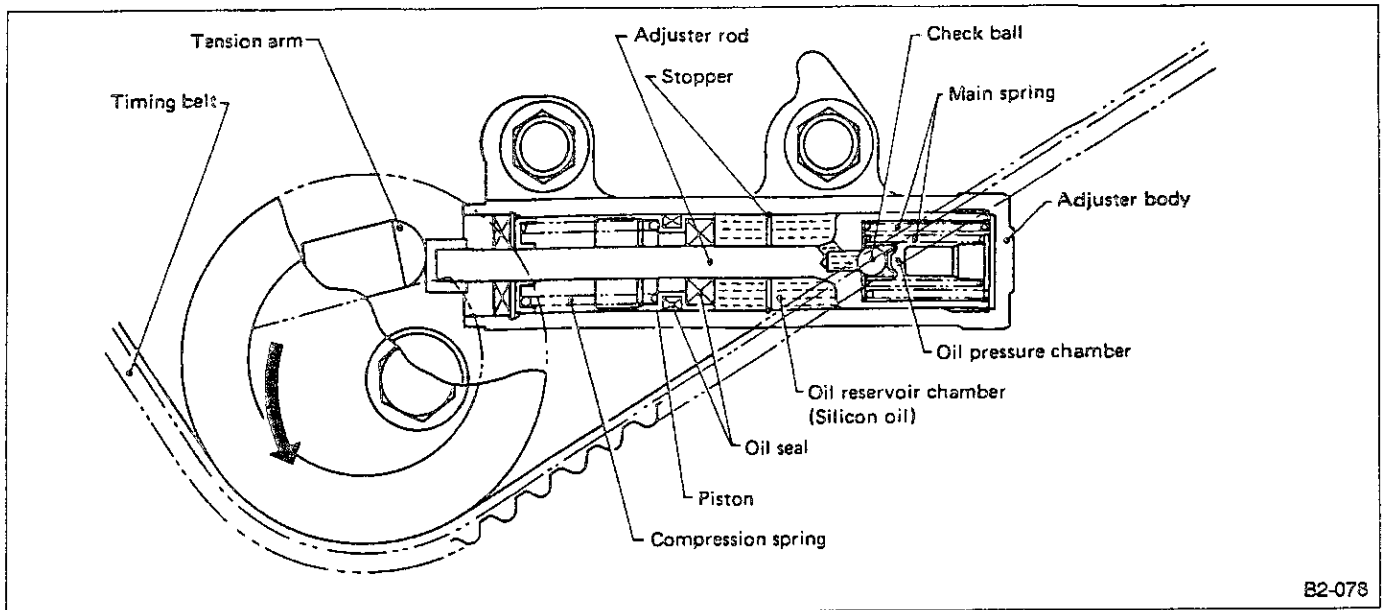


Fig. 3

4. Belt Cover

The belt cover is made of synthetic resin molding which is lightweight and heat resistant. It has a totally enclosed design that utilizes rubber packing at the mating surface of the cylinder block. This eliminates the chance of dust and water from entering the interior.

A floating design is utilized by placing rubber mounting between the cylinder block and belt cover to prevent the transmission of noise and vibration.

The front belt cover has a graduated line for ignition-timing confirmation.

5. Hydraulic Lash Adjuster

The hydraulic lash adjuster utilizes hydraulic action to maintain the valve clearances at zero at all times, thereby eliminating the need for clearance adjustment

and providing quiet engine operation.

A total of 16 lash adjusters (one per valve) are arranged in combination with the valve rocker on the DOHC engine.

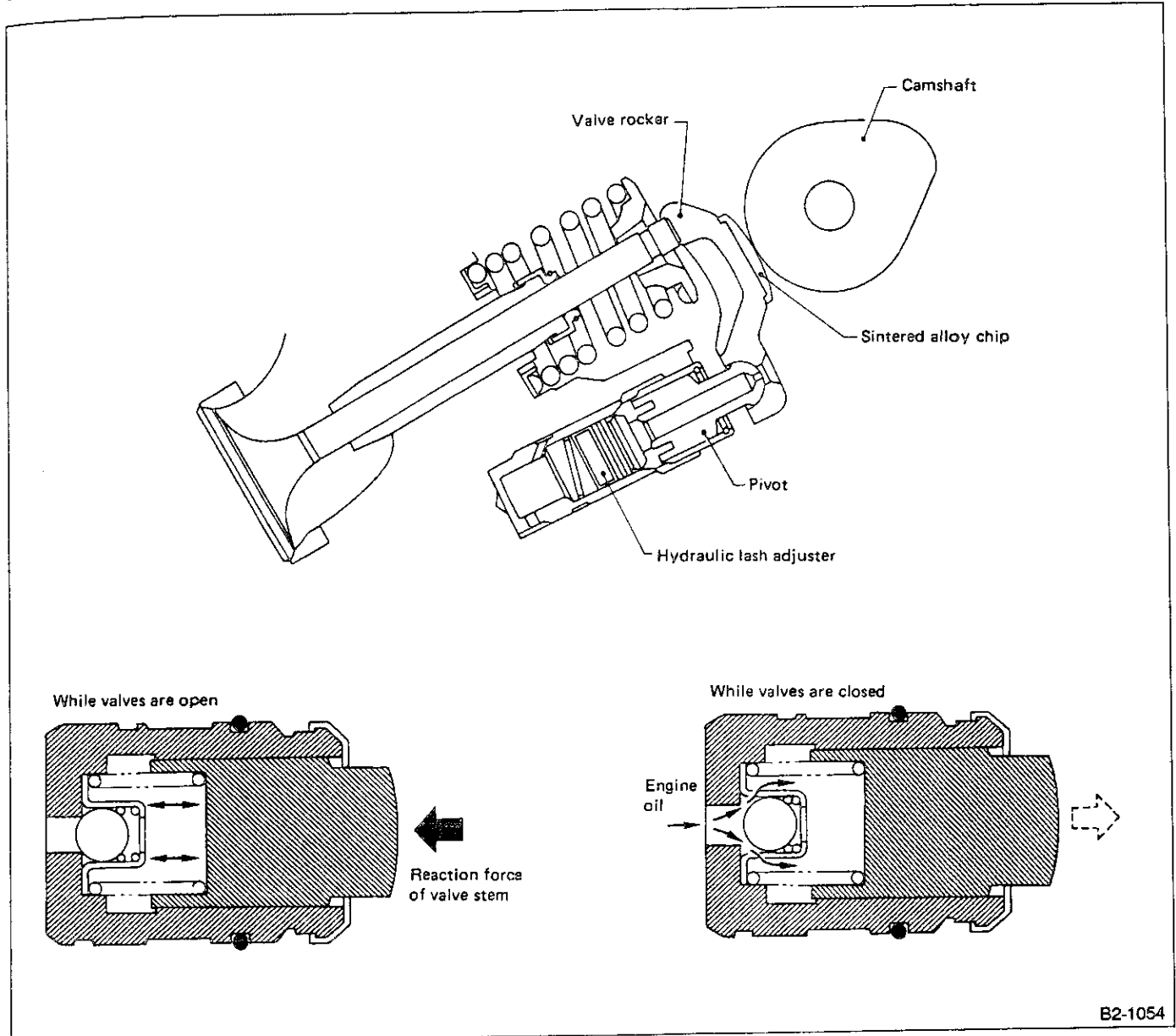


Fig. 4

6. Camshaft

The DOHC engine uses four camshafts in all; intake and exhaust camshafts on the RH bank and intake and exhaust camshafts on the LH bank.

The cam nose part is finished with "chill" treatment to increase wear resistance and anti-scuffing properties.

Each camshaft is supported by three journals with the camshaft caps. Each camshaft flange is supported by a groove provided in the cylinder head to receive thrust force.

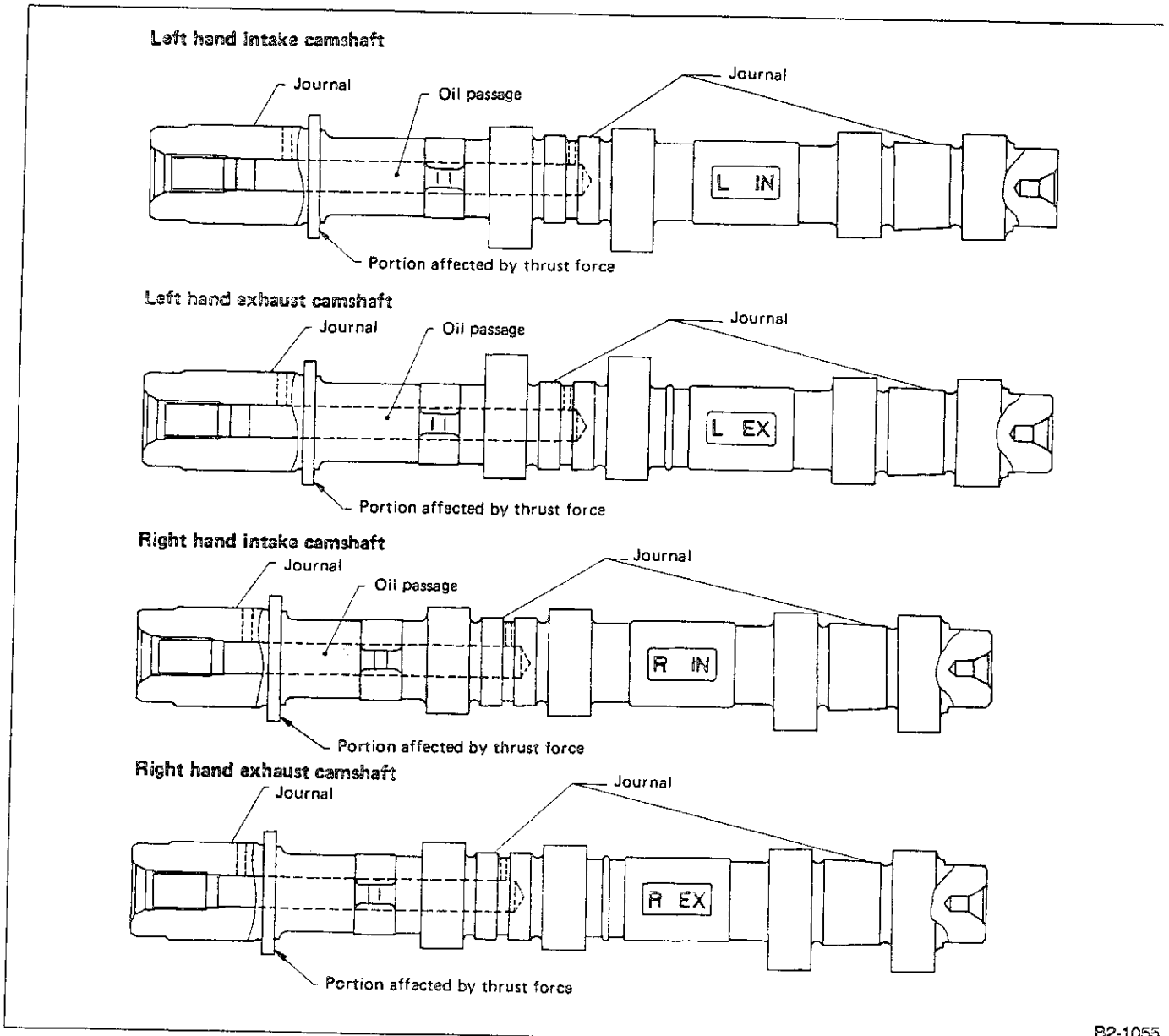


Fig. 5

B2-1055

7. Cylinder Head

Combustion chambers in the cylinder head are compact, center plug, pentroof types which feature a wide "squish" area for increased combustion efficiency.

Four valves (two intake and two exhaust), which are arranged in a cross-flow design, are used per cylinder.

The cylinder head gasket is made from carbon material (not asbestos). Its core is metal provided with metal hooks to increase resistance to both heat and wear. The inner side of grommets used in the cylinder bore are reinforced with wire to withstand both high combustion pressure and temperature.

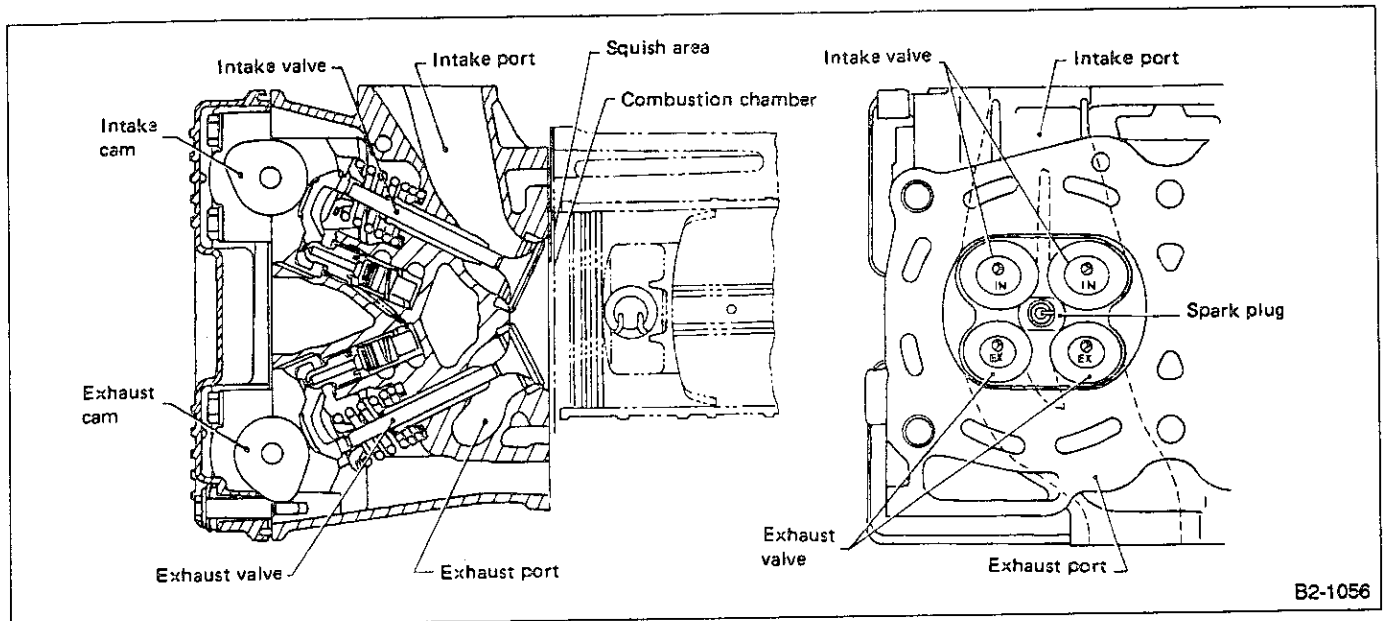


Fig. 6

8. Cylinder Block

The cylinder block is made from aluminum diecasting. The cylinder perimeter has a closed-deck design to increase rigidity of the surface mated with the cylinder head and withstand high turbocharged engine output. The cylinder liners are made from cast iron and are dry types which are totally cast with aluminum cylinder block. Five main journal block designs are employed to increase stiffness and quiet operation. The oil pump is located in the front center of the cylinder block and the water pump is located at the front of the left-cylinder bank. At the rear of the right-cylinder bank is a separator which eliminates oil mist contained in the blow-by gas.

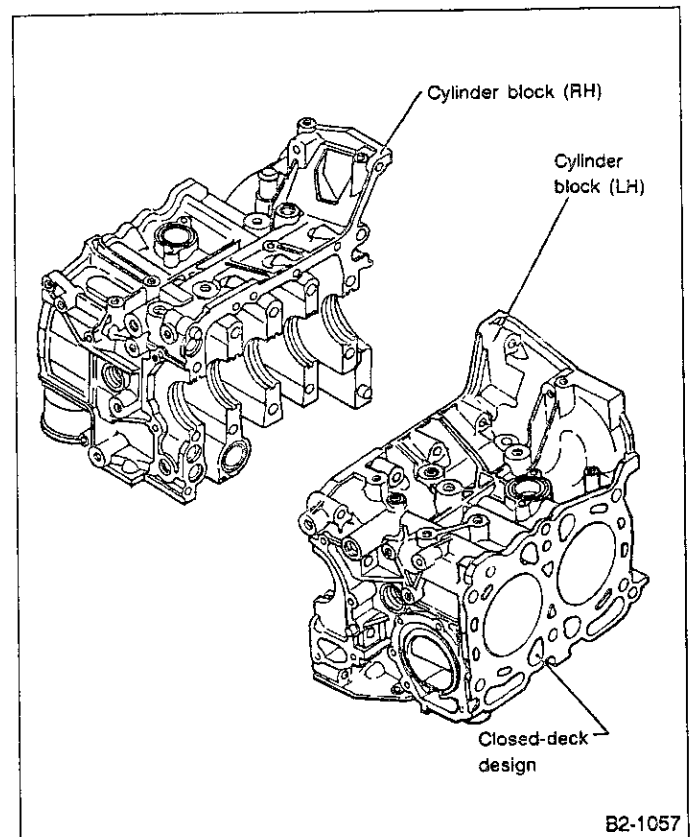
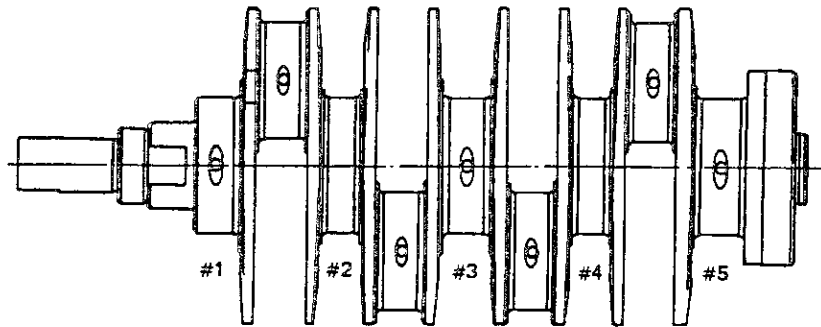


Fig. 7

9. Crankshaft

The crankshaft is supported by five bearings to provide high rigidity and strength. The corners of the crankshaft journals and webs, as well as the crank pins and webs,

are finished with fillet-roll work to increase stiffness. The five crankshaft bearings are made from aluminum alloy and the No. 3 bearing is provided with a flanged metal to receive thrust force.



B2-084

Fig. 8

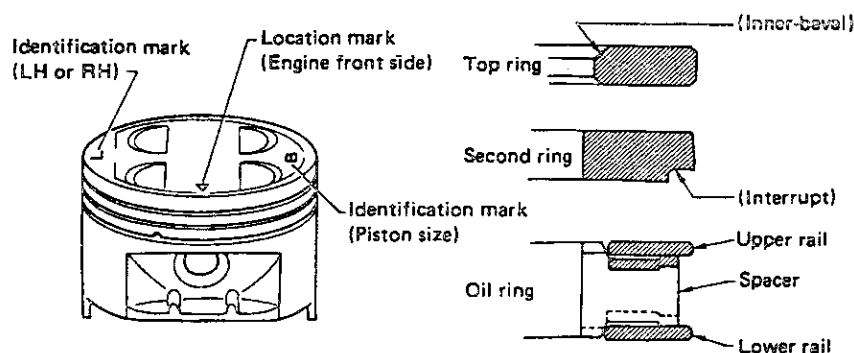
10. Piston

The piston skirt has a "slipper" design to reduce weight and sliding. The top ring groove is treated with alumite to increase wear resistance. The oil control ring groove utilizes a thermal flow design and is provided with a slot.

The piston pin is located in an offset position. The Nos. 1 and 3 pistons are offset in the lower direction while the Nos. 2 and 4 pistons are offset in the upper direction.

The piston head is recessed for both the intake and exhaust valves. It also has symbols used to identify the location and the direction of installation.

Three piston rings are used for each piston—two compression rings and one oil ring. The top piston ring has an inner-bevel design and the second piston ring has an interrupt design to reduce oil consumption.



B2-085

Fig. 9

S SPECIFICATIONS AND SERVICE DATA

A: SPECIFICATIONS

		2000 cc MPFI	
ENGINE	Type	Horizontally opposed, liquid cooled, 4-cylinder, 4-stroke gasoline engine	
	Valve arrangement	Belt driven, double over-head camshaft, 4-valve/cylinder	
	Bore x Stroke	mm (in) 92 x 75 (3.62 x 2.95)	
	Piston displacement	cm ³ (cu in) 1,994 (121.67)	
	Compression ratio	8.0	
	Compression pressure (at 200 - 300 rpm)	kPa (kg/cm ² , psi) 981 -- 1,177 (10 -- 12, 142 -- 171)	
	Number of piston rings	Pressure ring: 2, Oil ring: 1	
	Intake valve timing	Opening	3° BTDC
		Closing	55° ABDC
	Exhaust valve timing	Opening	55° BBDC
		Closing	11° ATDC
	Idling speed [At neutral or position]	rpm	900 ± 100 (No load)
	Firing order		1 → 3 → 2 → 4
Ignition timing	BTDC/rpm	18° ± 10°/900	

B: SERVICE DATA

Belt tension adjuster	Protrusion of adjuster rod		15.4 — 16.4 mm	(0.606 — 0.646 in)		
Belt tensioner	Spacer O.D.		16 mm	(0.63 in)		
	Tensioner bush I.D.		16.16 mm	(0.6362 in)		
	Clearance between spacer and bush	STD	0.117 — 0.180 mm	(0.0046 — 0.0071 in)		
		Limit	0.230 mm	(0.0091 in)		
	Side clearance of spacer	STD	0.37 — 0.54 mm	(0.0146 — 0.0213 in)		
Limit		0.8 mm	(0.031 in)			
Camshaft	Bend limit		0.20 mm	(0.0079 in)		
	Thrust clearance	STD	0.020 — 0.22 mm	(0.0008 — 0.0087 in)		
		Limit	0.35 mm	(0.0138 in)		
	Cam lobe height	Intake	*1	STD	39.41 — 39.51 mm	(1.5516 — 1.5555 in)
			Wear limit	0.26 mm	(0.0102 in)	
		Exhaust	*2	STD	38.88 — 38.98 mm	(1.5307 — 1.5346 in)
			Wear limit	0.28 mm	(0.0110 in)	
	Journal O.D.	STD	Front	31.946 — 31.963 mm	(1.2577 — 1.2584 in)	
			Center Rear	27.946 — 27.963 mm	(1.1002 — 1.1009 in)	
	Oil clearance	STD	0.037 — 0.072 mm	(0.0015 — 0.0028 in)		
		Limit	0.10 mm	(0.0039 in)		
Cylinder head	Surface warpage limit		0.05 mm	(0.0020 in)		
	Surface grinding limit		0.3 mm	(0.012 in)		
	Standard height		127.5 mm	(5.020 in)		
Valve seat	Refacing angle		90°			
	Contacting width	Intake	STD	1.0 mm	(0.039 in)	
			Limit	1.7 mm	(0.067 in)	
		Exhaust	STD	1.5 mm	(0.059 in)	
			Limit	2.2 mm	(0.087 in)	
Valve guide	Inner diameter		6.600 — 6.615 mm	(0.2598 — 0.2604 in)		
	Protrusion above head		13.3 — 13.7 mm	(0.524 — 0.539 in)		
Valve	Head edge thickness	Intake	STD	1.2 mm	(0.047 in)	
			Limit	0.8 mm	(0.031 in)	
		Exhaust	STD	1.5 mm	(0.059 in)	
			Limit	0.8 mm	(0.031 in)	
	Stem diameter	Intake	6.550 — 6.565 mm	(0.2579 — 0.2585 in)		
		Exhaust	6.560 — 6.565 mm	(0.2583 — 0.2585 in)		
	Stem oil clearance	STD	Intake	0.035 — 0.062 mm	(0.0014 — 0.0024 in)	
			Exhaust	0.040 — 0.067 mm	(0.0016 — 0.0026 in)	
Limit		0.15 mm	(0.0059 in)			
Overall length	Intake	97.97mm	(3.8571 in)			
	Exhaust	97.57 mm	(3.8413 in)			

STD: Standard ID: Inner diameter OD: Outer diameter

*1, *2 Refer. to [W3B1].

Valve spring	Free length		40.7 mm	(1.602 in)		
	Squareness		2.5°, 1.8 mm	(0.071 in)		
	Tension/spring height		163.8 — 188.3 N (16.7 — 19.2 kg, 36.8 — 42.3 lb)/35 mm (1.38 in) 473.7 — 524.7 N (48.3 — 53.5 kg, 106.5 — 113.0 lb)/ 27.0 mm (1.063 in)			
Cylinder block	Surface warpage limit (mating with cylinder head)		0.05 mm	(0.0020 in)		
	Surface grinding limit		0.1 mm	(0.004 in)		
	Cylinder bore	2000cc	A	92.005 — 92.015 mm	(3.6222 — 3.6225 in)	
			B	91.995 — 92.005 mm	(3.6218 — 3.6222 in)	
			C	91.985 — 91.995 mm	(3.6214 — 3.6218 in)	
	Taper	STD		0.015 mm	(0.0006 in)	
		Limit		0.050 mm	(0.0020 in)	
	Out-of-roundness	STD		0.010 mm	(0.0004 in)	
		Limit		0.050 mm	(0.0020 in)	
	Piston clearance	STD		0.010 — 0.030 mm	(0.0004 — 0.0012 in)	
Limit		0.060 mm	(0.0024 in)			
Enlarging (boring) limit		0.5 mm		(0.020 in)		
Piston	Outer diameter	2000cc	STD	A	91.985 — 91.995 mm	(3.6214 — 3.6218 in)
				B	91.975 — 91.985 mm	(3.6211 — 3.6214 in)
				C	91.965 — 91.975 mm	(3.6207 — 3.6211 in)
			0.25 mm (0.0098 in) OS	92.225 — 92.235 mm	(3.6309 — 3.6313 in)	
			0.50 mm (0.0197 in) OS	92.475 — 92.485 mm	(3.6407 — 3.6411 in)	
Standard inner diameter of piston pin hole		23.000 — 23.006 mm		(0.9055 — 0.9057 in)		
Piston pin	Outer diameter		22.994 — 23.000 mm		(0.9053 — 0.9055 in)	
	Standard clearance between piston pin and hole in piston		0.001 — 0.013 mm		(0.00004 — 0.00051 in)	
	Degree of fit		Piston pin must be fitted into position with thumb at 20°C (68°F).			
Piston ring	Piston ring gap	Top ring	STD	0.20 — 0.35 mm	(0.0079 — 0.0138 in)	
			Limit	1.0 mm	(0.039 in)	
		Second ring	STD	0.20 — 0.35 mm	(0.0079 — 0.0138 in)	
			Limit	1.0 mm	(0.039 in)	
	Oil ring	STD	0.20 — 0.70 mm	(0.0079 — 0.0276 in)		
		Limit	1.5 mm	(0.059 in)		
	Clearance between piston ring and piston ring groove	Top ring	STD	0.040 — 0.080 mm	(0.0016 — 0.0031 in)	
			Limit	0.15 mm	(0.0059 in)	
Second ring		STD	0.030 — 0.070 mm	(0.0012 — 0.0028 in)		
		Limit	0.15 mm	(0.0059 in)		
Connecting rod	Bend twist per 100 mm (3.94 in) in length		Limit	0.10 mm	(0.0039 in)	
	Side clearance	STD		0.070 — 0.330 mm	(0.0028 — 0.0130 in)	
		Limit		0.4 mm	(0.016 in)	

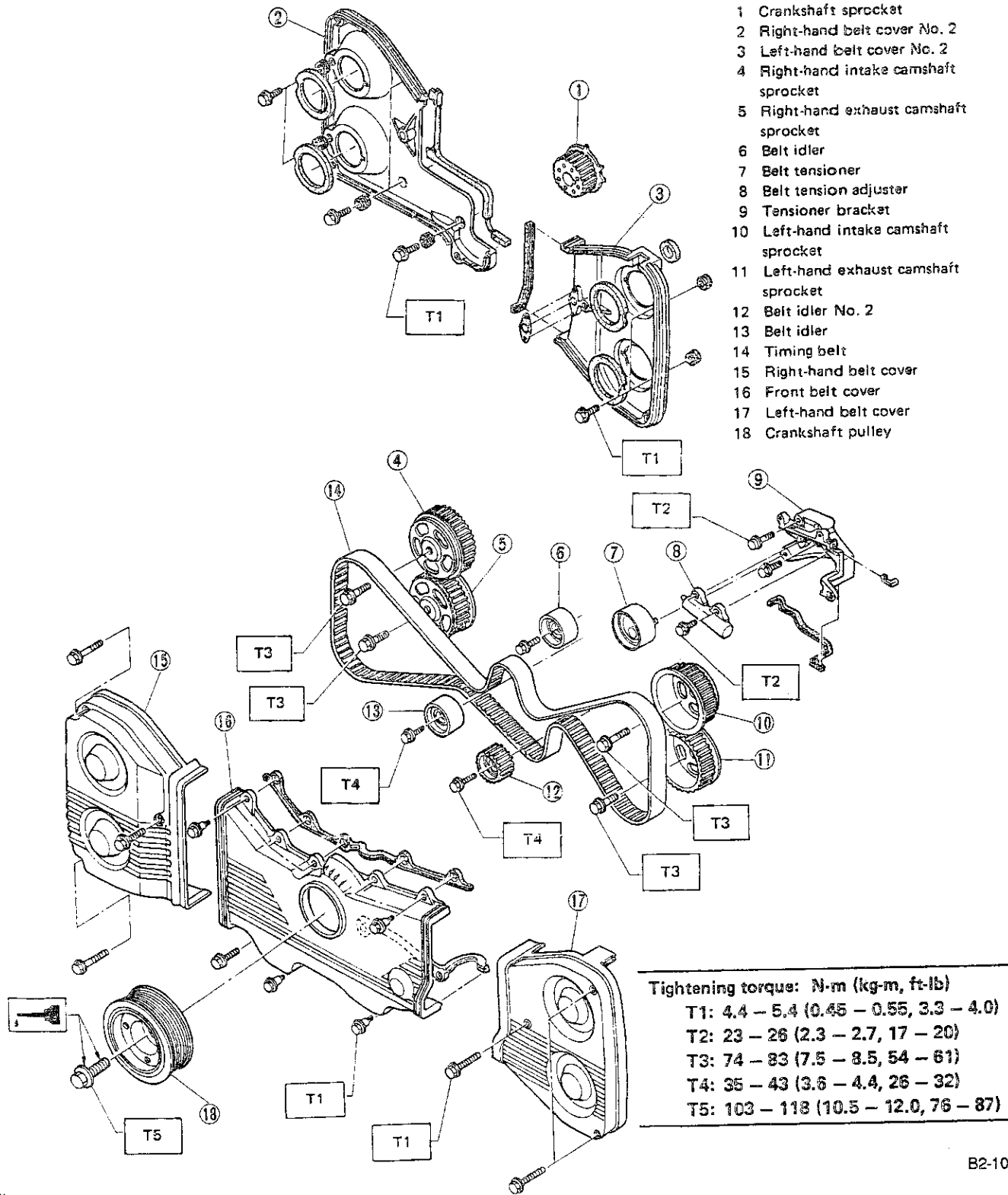
STD: Standard OS: Oversize

Connecting rod bearing	Oil clearance		STD	0.025 — 0.055 mm	(0.0010 — 0.0022 in)
			Limit	0.06 mm	(0.0024 in)
	Thickness at center portion	STD		1.487 — 1.496 mm	(0.0585 — 0.0589 in)
		0.03 mm (0.0012) US		1.505 — 1.508 mm	(0.0593 — 0.0594 in)
		0.05 mm (0.0020) US		1.515 — 1.518 mm	(0.0596 — 0.0598 in)
0.25 mm (0.0098 in) US		1.615 — 1.618 mm	(0.0636 — 0.0637 in)		
Connecting rod bushing	Clearance between piston pin and bushing		STD	0 — 0.022 mm	(0 — 0.0009 in)
			Limit	0.030 mm	(0.0012 in)
Crankshaft	Bend limit			0.035 mm	(0.0014 in)
	Crankpin and crank journal	Out-of roundness		0.030 mm (0.0012 in) or less	
		Grinding limit		0.250 mm	(0.0098 in)
	Crankpin outer diameter	STD		51.984 — 52.000 mm	(2.0466 — 2.0472 in)
		0.03 mm (0.0012 in) US		51.954 — 51.970 mm	(2.0454 — 2.0461 in)
		0.05 mm (0.0020 in) US		51.934 — 51.950 mm	(2.0446 — 2.0453 in)
		0.25 mm (0.0098 in) US		51.734 — 51.750 mm	(2.0368 — 2.0374 in)
	Crank journal outer diameter	STD		59.984 — 60.000 mm	(2.3616 — 2.3622 in)
		0.03 mm (0.0012 in) US		59.954 — 59.970 mm	(2.3604 — 2.3610 in)
		0.05 mm (0.0020 in) US		59.934 — 59.950 mm	(2.3596 — 2.3602 in)
		0.25 mm (0.0098 in) US		59.734 — 59.750 mm	(2.3517 — 2.3524 in)
	Thrust clearance	STD		0.030 — 0.115 mm	(0.0012 — 0.0045 in)
		Limit		0.25 mm	(0.0098 in)
	Oil clearance	#1, #5	STD	0.010 — 0.030 mm	(0.0004 — 0.0012 in)
			Limit	0.040 mm	(0.0016 in)
		#2, #3, #4	STD	0.010 — 0.030 mm	(0.0004 — 0.0012 in)
Limit			0.035 mm	(0.0014 in)	
Crankshaft bearing	Crankshaft bearing thickness	#1, #5	STD	1.998 — 2.011 mm	(0.0787 — 0.0792 in)
			0.03 mm (0.0012 in) US	2.017 — 2.020 mm	(0.0794 — 0.0795 in)
			0.05 mm (0.0020 in) US	2.027 — 2.030 mm	(0.0798 — 0.0799 in)
			0.25 mm (0.0098 in) US	2.127 — 2.130 mm	(0.0837 — 0.0839 in)
		#2, #3, #4	STD	2.000 — 2.013 mm	(0.0787 — 0.0793 in)
			0.03 mm (0.0012 in) US	2.019 — 2.022 mm	(0.0795 — 0.0796 in)
			0.05 mm (0.0020 in) US	2.029 — 2.032 mm	(0.0799 — 0.0800 in)
			0.25 mm (0.0098 in) US	2.129 — 2.132 mm	(0.0838 — 0.0839 in)

STD: Standard US: Under size

C COMPONENT PARTS

1. Timing Belt



- 1 Crankshaft sprocket
- 2 Right-hand belt cover No. 2
- 3 Left-hand belt cover No. 2
- 4 Right-hand intake camshaft sprocket
- 5 Right-hand exhaust camshaft sprocket
- 6 Belt idler
- 7 Belt tensioner
- 8 Belt tension adjuster
- 9 Tensioner bracket
- 10 Left-hand intake camshaft sprocket
- 11 Left-hand exhaust camshaft sprocket
- 12 Belt idler No. 2
- 13 Belt idler
- 14 Timing belt
- 15 Right-hand belt cover
- 16 Front belt cover
- 17 Left-hand belt cover
- 18 Crankshaft pulley

Tightening torque: N-m (kg-m, ft-lb)	
T1:	4.4 - 5.4 (0.45 - 0.55, 3.3 - 4.0)
T2:	23 - 26 (2.3 - 2.7, 17 - 20)
T3:	74 - 83 (7.5 - 8.5, 54 - 61)
T4:	35 - 43 (3.6 - 4.4, 26 - 32)
T5:	103 - 118 (10.5 - 12.0, 76 - 87)

Fig. 10

2. Cylinder Head and Camshaft

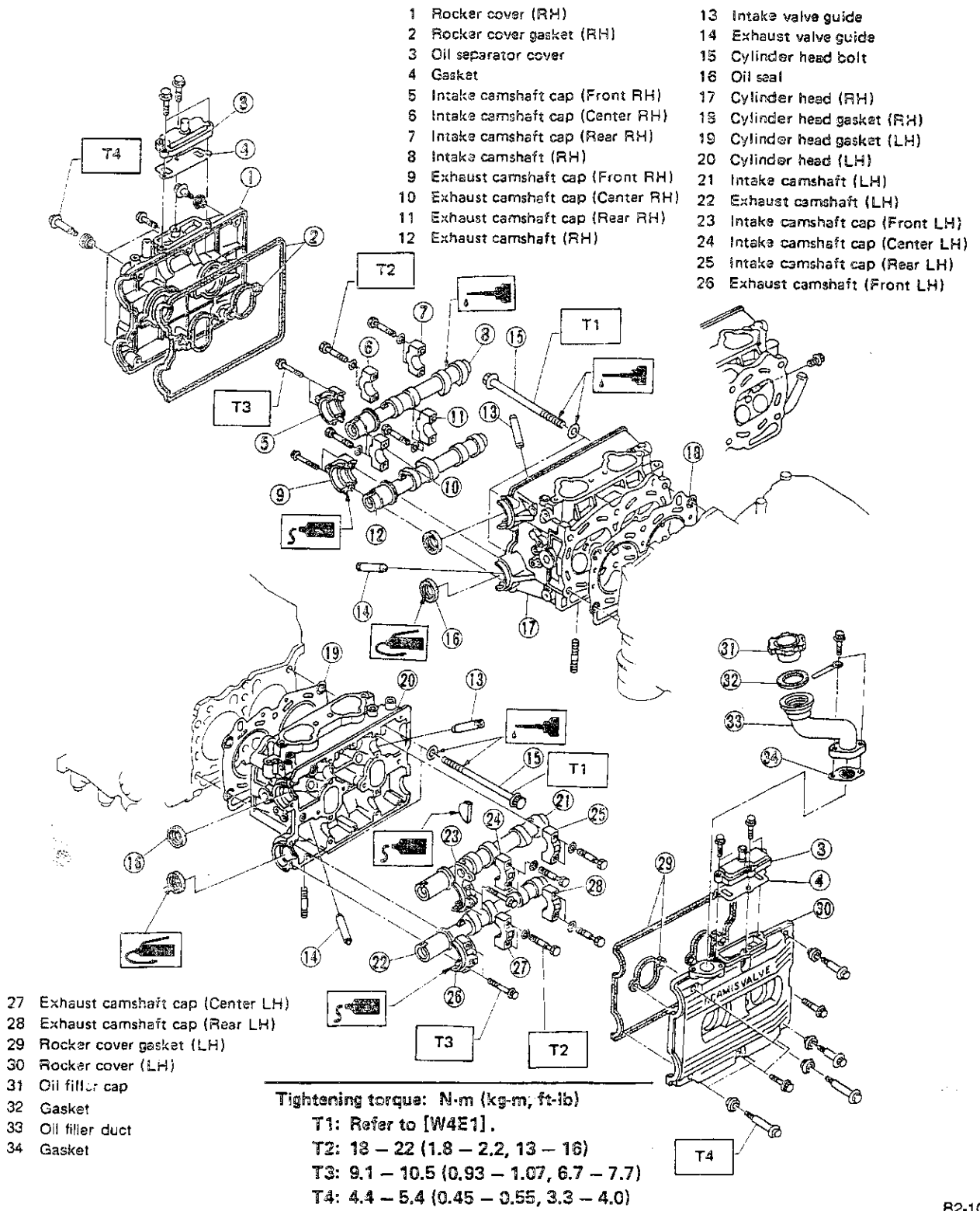


Fig. 11

3. Cylinder Head and Valve ASSY

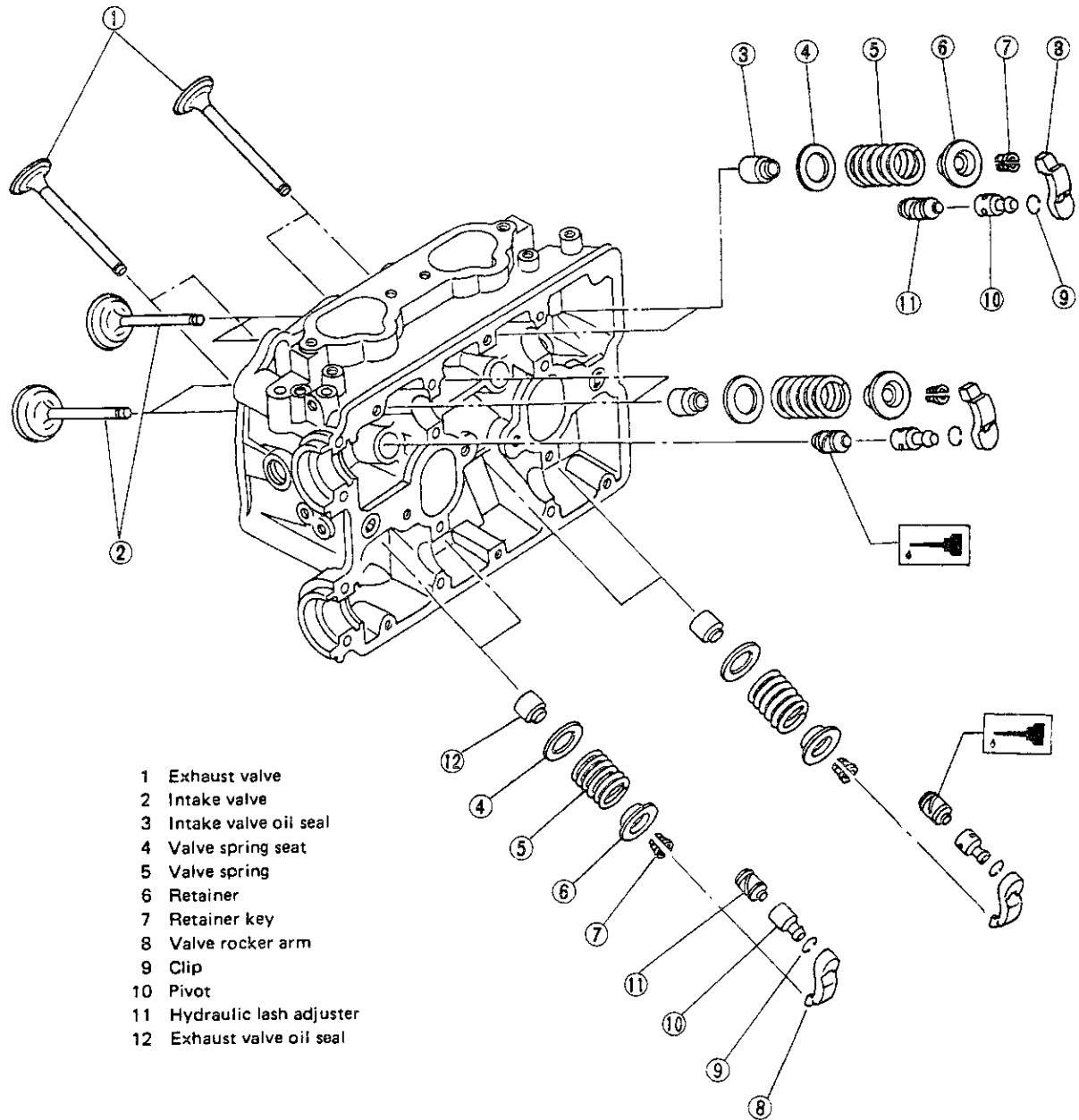


Fig. 12

B2-1060

4. Cylinder Block

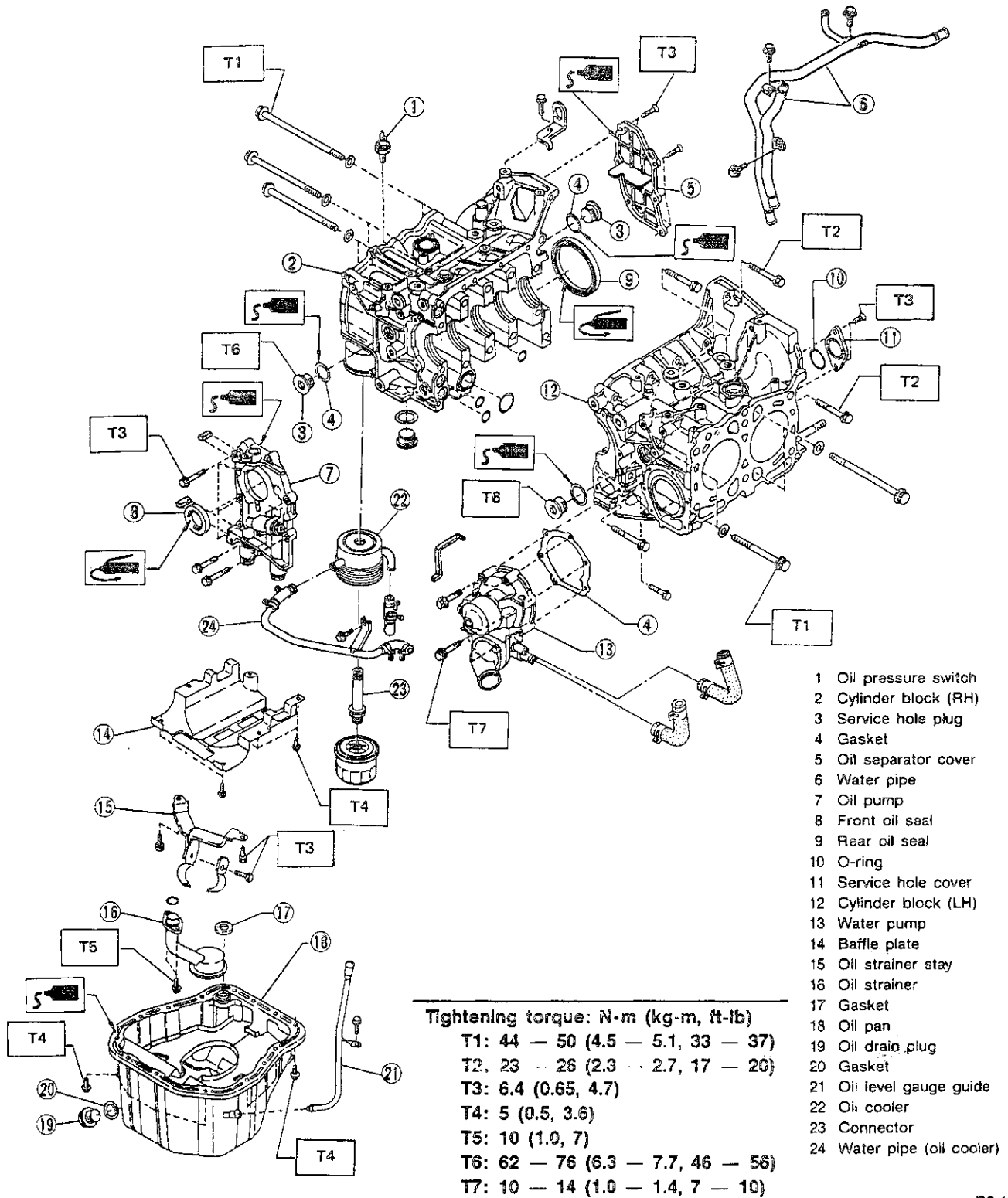


Fig. 13

B2-1061

5. Crankshaft and Piston

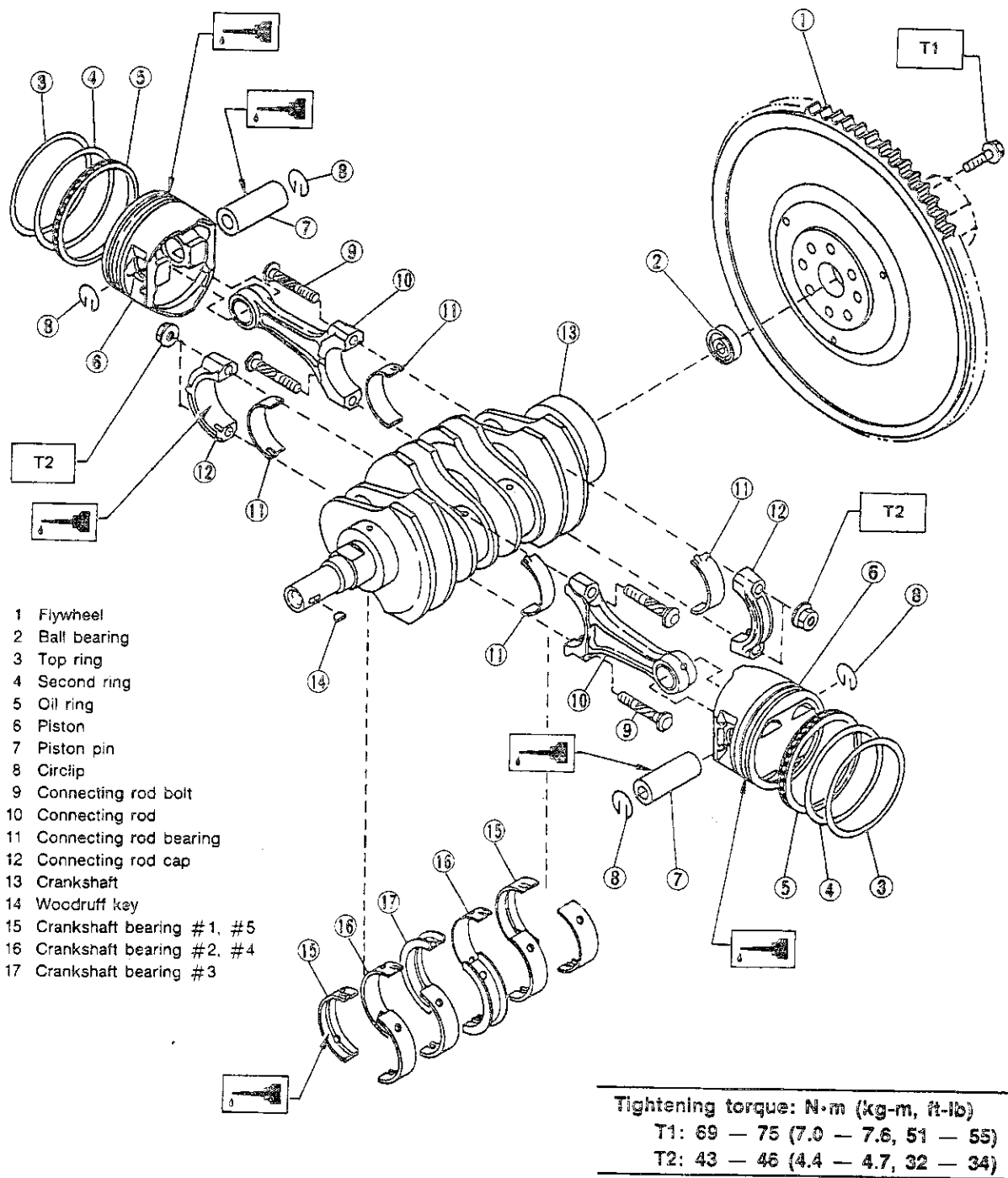


Fig. 14

B2-1062

W SERVICE PROCEDURE

1. General Precautions

1) Before disassembling engine, place it on ENGINE STAND.

On turbocharged engine, remove exhaust manifolds, turbo joint pipe and turbocharger before placing it on ENGINE STAND.

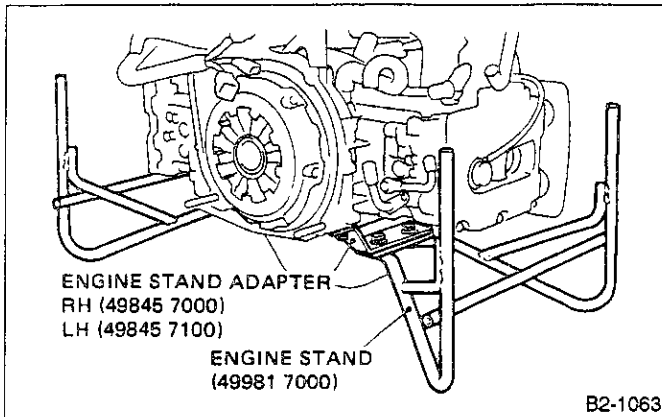


Fig. 15

2) All parts should be thoroughly cleaned, paying special attention to the engine oil passages, pistons and bearings.

3) Rotating parts and sliding parts such as piston, bearing and gear should be coated with oil prior to assembly.

4) Be careful not to let oil, grease or coolant contact the timing belt, clutch disc and flywheel.

5) All removed parts, if to be reused, should be reinstalled in the original positions and directions.

6) Gaskets and lock washers must be replaced with new ones. Liquid gasket should be used where specified to prevent leakage.

7) Bolts, nuts and washers should be replaced with new ones as required.

8) Even if necessary inspections have been made in advance, proceed with assembly work while making rechecks.

2. Timing Belt

A: REMOVAL

1. CRANKSHAFT PULLEY AND BELT COVER

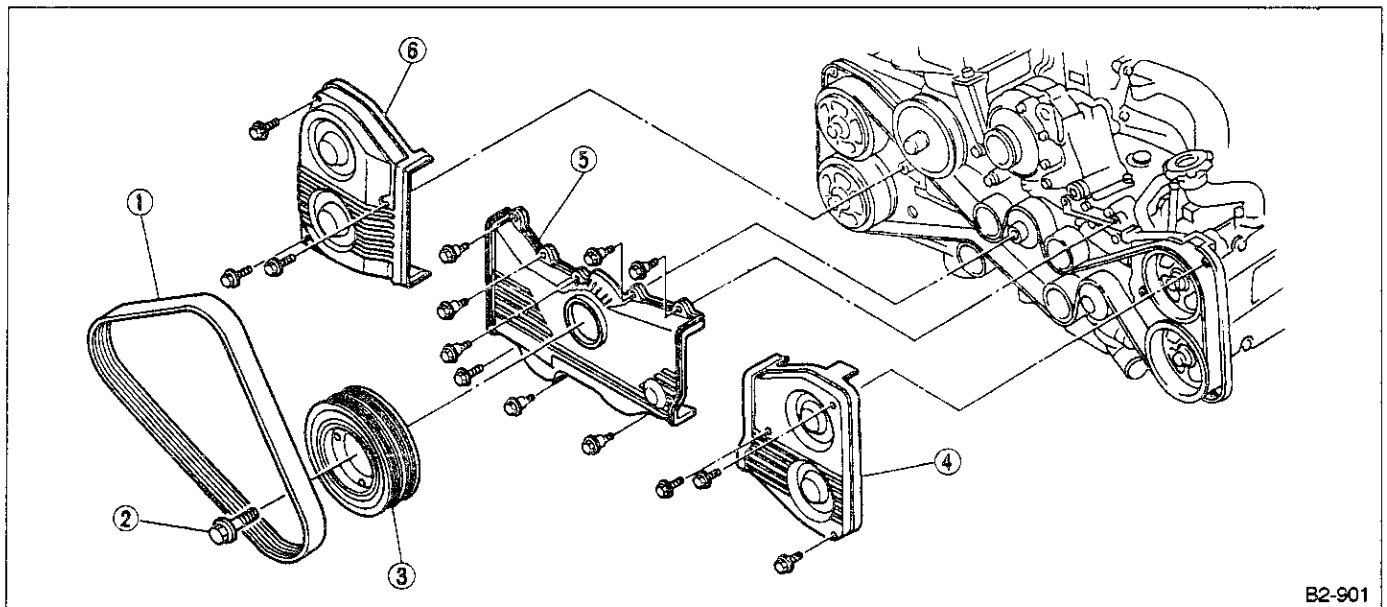
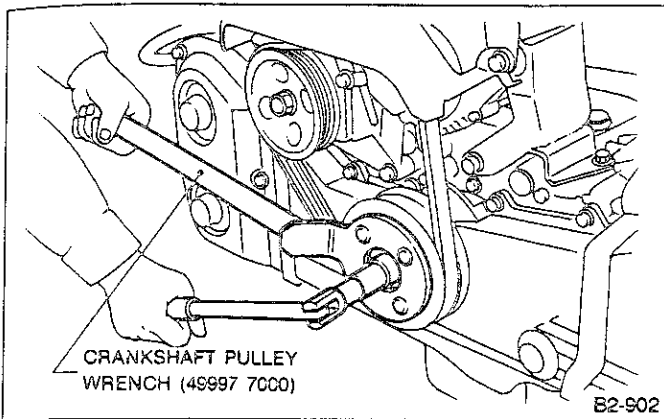


Fig. 16

1) Remove V-belt.

2) Remove pulley bolt. To lock crankshaft, use Special Tool.



- 3) Remove crankshaft pulley.
- 4) Remove left-hand belt cover.
- 5) Remove right-hand belt cover.
- 6) Remove front belt cover.

Fig. 17

2. TIMING BELT

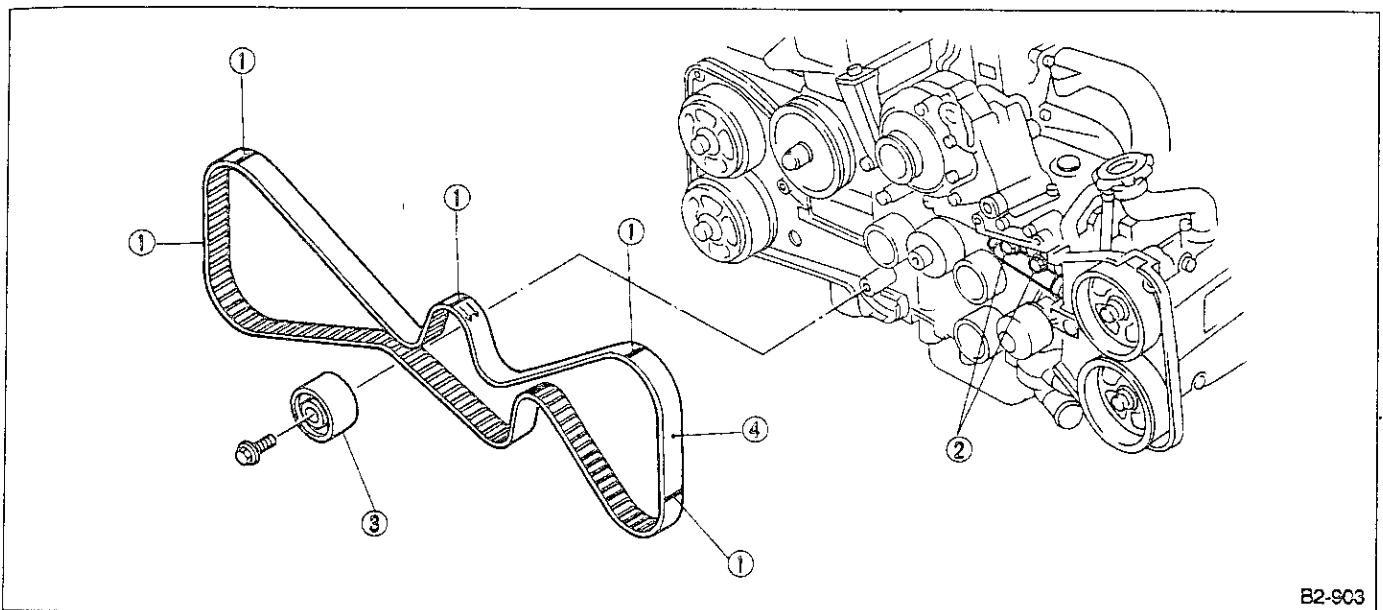


Fig. 18

1) If alignment mark and/or arrow mark (which indicates rotation direction) on timing belt fade away, put new marks before removing timing belt as follows:

(1) Turn crankshaft, and align alignment marks on crankshaft sprocket, left-hand intake camshaft sprocket, left-hand exhaust camshaft sprocket, right-hand intake camshaft sprocket and right hand

exhaust camshaft sprocket with notches of belt cover and cylinder block.

Special tool: CRANKSHAFT SOCKET (499987500)

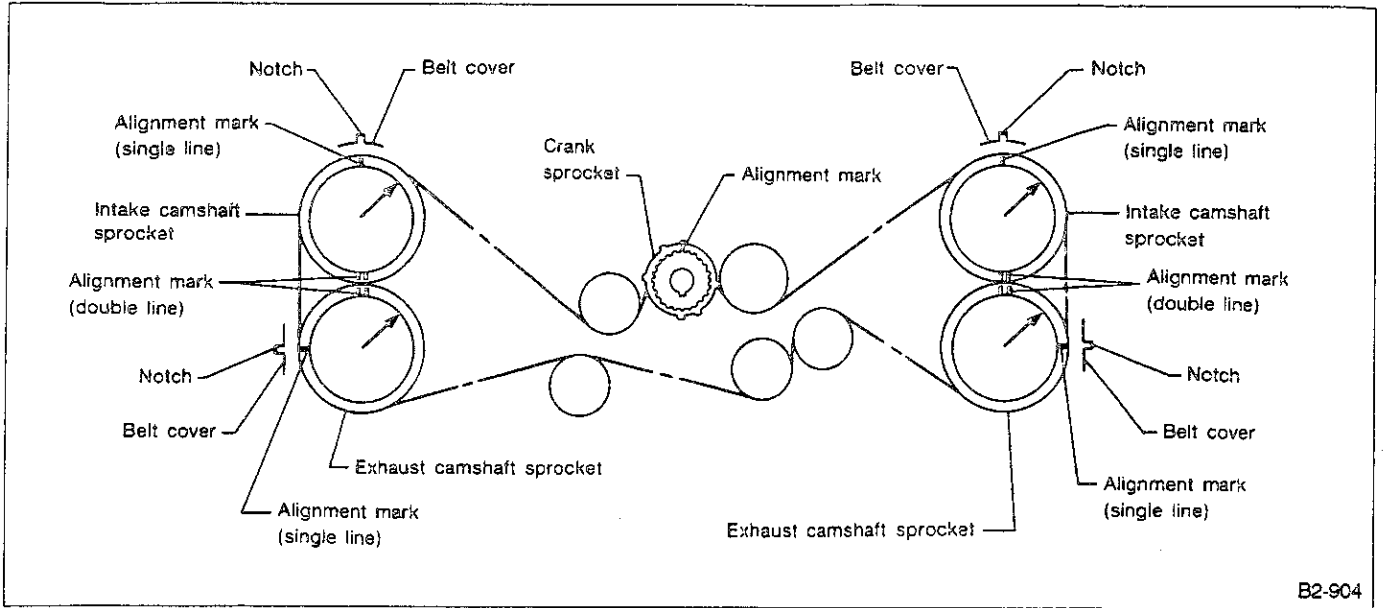


Fig. 19

(2) Using white paint, put alignment and/or arrow marks on timing belts in relation to the sprockets.

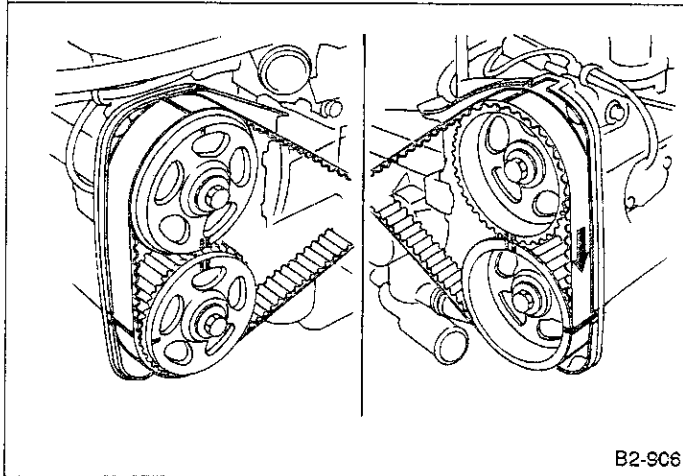
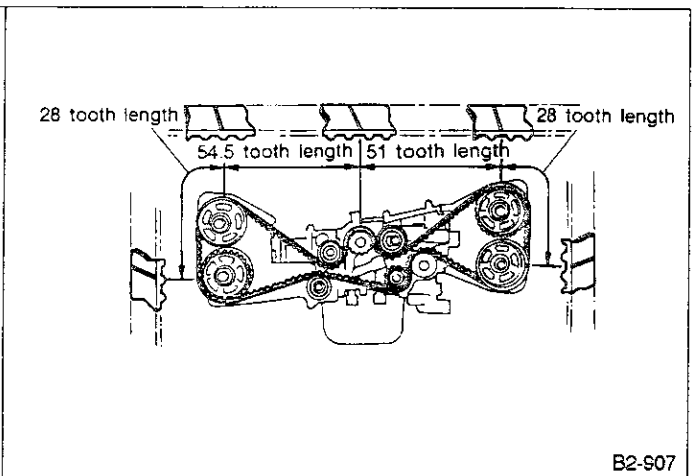
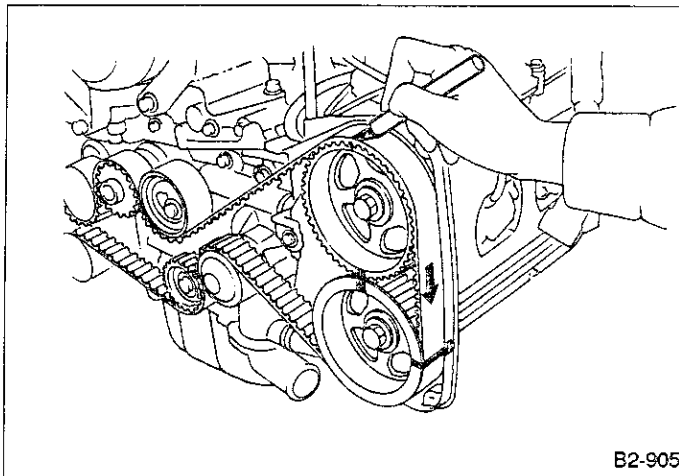
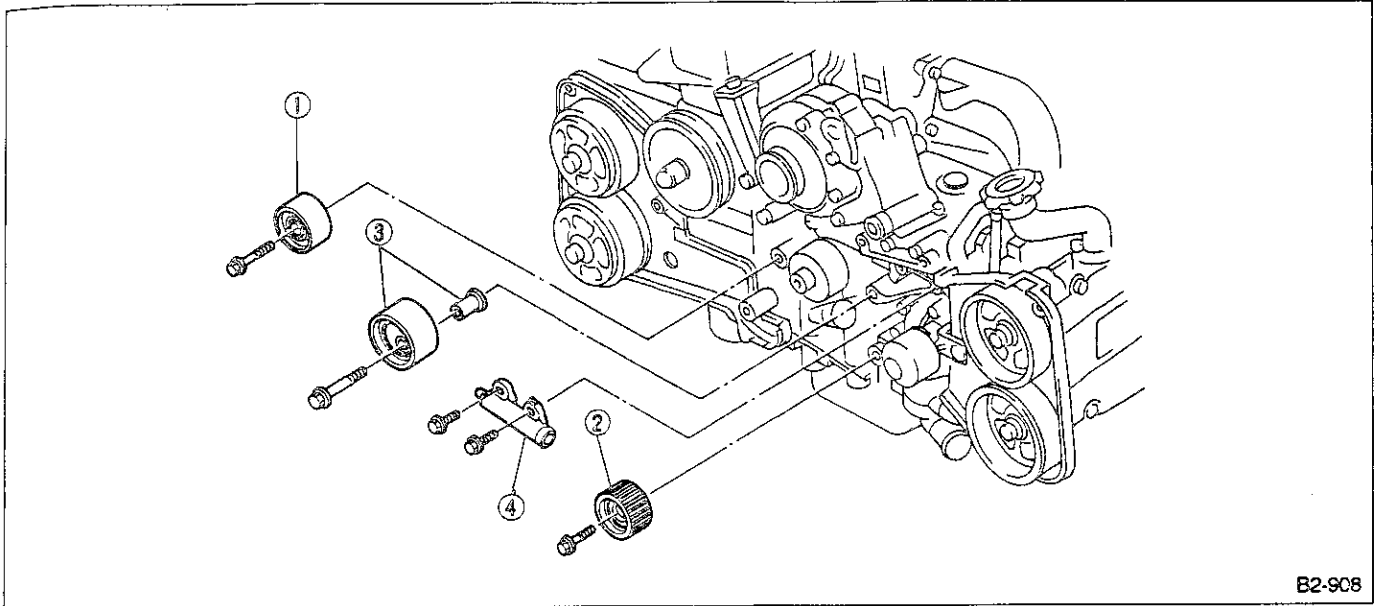


Fig. 20

- 2) Loosen tensioner adjuster mounting bolts.
- 3) Remove belt idler.

- 4) Remove timing belt.

3. BELT TENSIONER AND IDLER



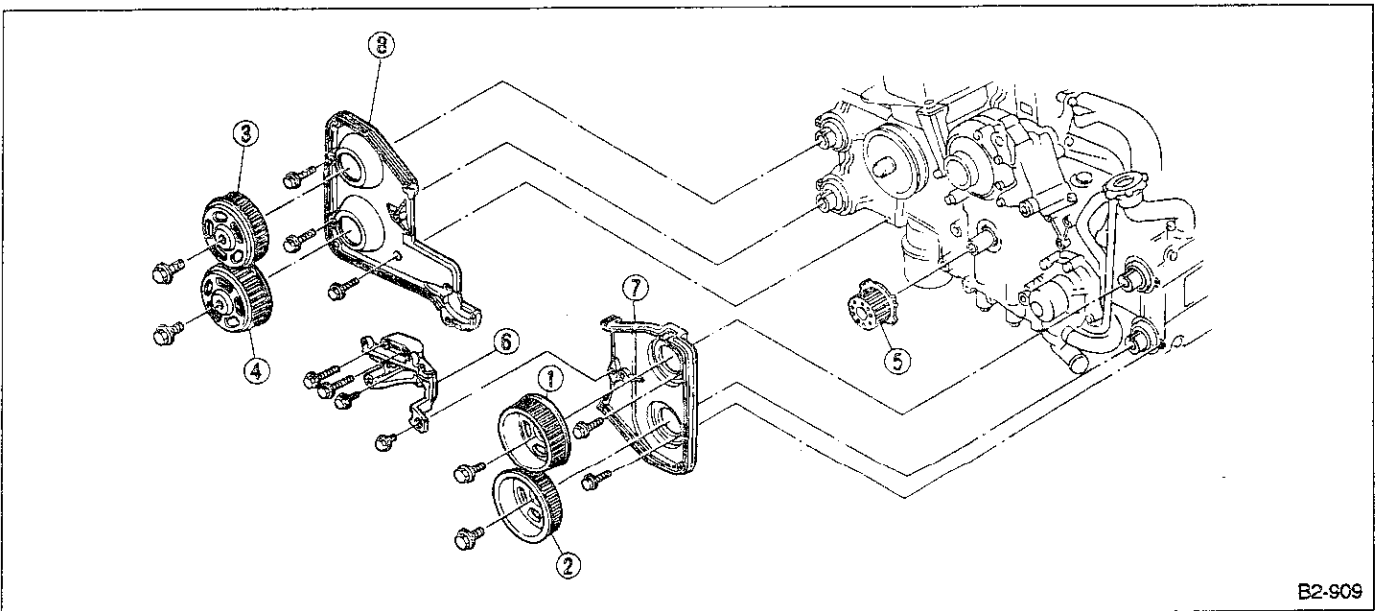
B2-908

Fig. 21

- 1) Remove belt idler.
- 2) Remove belt idler No. 2.

- 3) Remove belt tensioner and spacer.
- 4) Remove belt tension adjuster.

4. SPROCKET



B2-909

Fig. 22

After timing belt has been removed, never rotate intake and exhaust, camshaft sprocket.

If camshaft sprocket is rotated, the intake and exhaust valve heads strike together and valve stems are bent. For this reason, when removing camshaft sprocket, lock the camshaft sprocket using CAMSHAFT SPROCKET WRENCH so as to avoid turning camshaft.

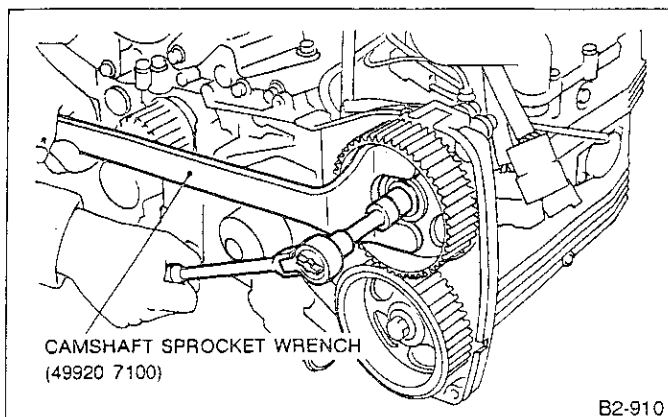


Fig. 23

- 1) Remove left-hand intake camshaft sprocket.
- 2) Remove left-hand exhaust camshaft sprocket.
- 3) Remove right-hand intake camshaft sprocket.
- 4) Remove right-hand exhaust camshaft sprocket.
- 5) Remove crankshaft sprocket.
- 6) Remove tensioner bracket.
- 7) Remove left-hand belt cover No. 2.
- 8) Remove right-hand belt cover No. 2.

B: INSPECTION

1. TIMING BELT

- 1) Check timing belt teeth for breaks, cracks, and wear. If any fault is found, replace belt.
- 2) Check the condition of back side of belt; if any crack is found, replace belt.
 - a. Be careful not to let oil, grease or coolant contact the belt. Remove quickly and thoroughly if this happens.
 - b. Do not bend the belt sharply. [The bending radius must be greater than 60 mm (2.36 in).]

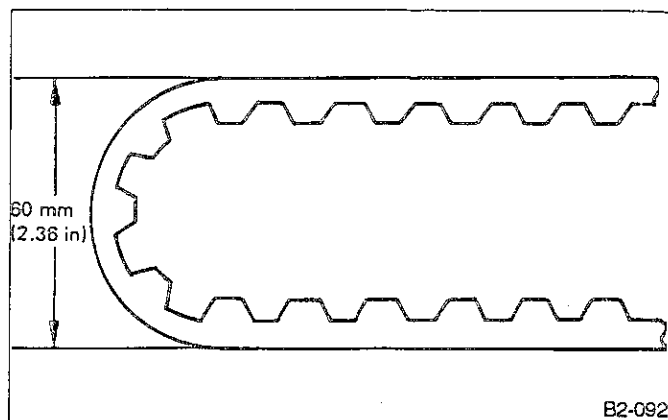


Fig. 24

2. BELT TENSION ADJUSTER

- 1) Visually check oil seals for leaks, and rod ends for abnormal wear or scratches. If necessary, replace faulty parts.

Slight traces of oil at rod' oil seal does not indicate a problem.

- 2) While holding tensioner with both hands, push the rod section against floor or wall with a force of 147 to 490 N (15 to 50 kg, 33 to 110 lb) to ensure that the rod section does not move. If it moves, replace tension adjuster with a new one.
- 3) Measure the extension of rod beyond the body. If it is not within specifications, replace with a new one.

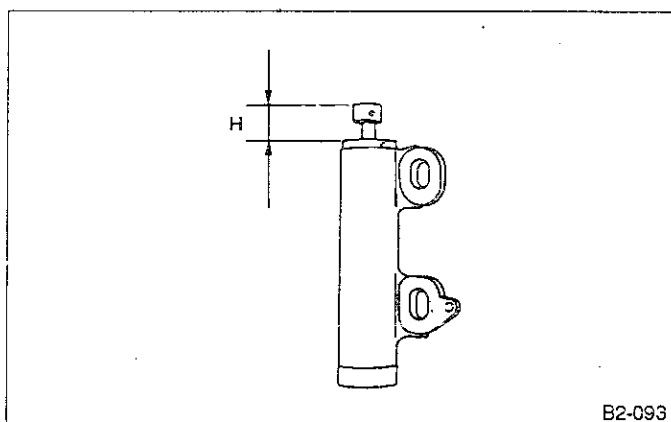


Fig. 25

Rod extension H:
15.4 — 16.4 mm (0.606 — 0.646 in)

3. BELT TENSIONER

- 1) Check mating surfaces of timing belt and contact point of tension adjuster rod for abnormal wear or scratches. Replace belt tensioner if faulty.
- 2) Check spacer and tensioner bushing for wear.

4. BELT IDLER

Check idler for smooth rotation. Replace if noise or excessive play is noted.

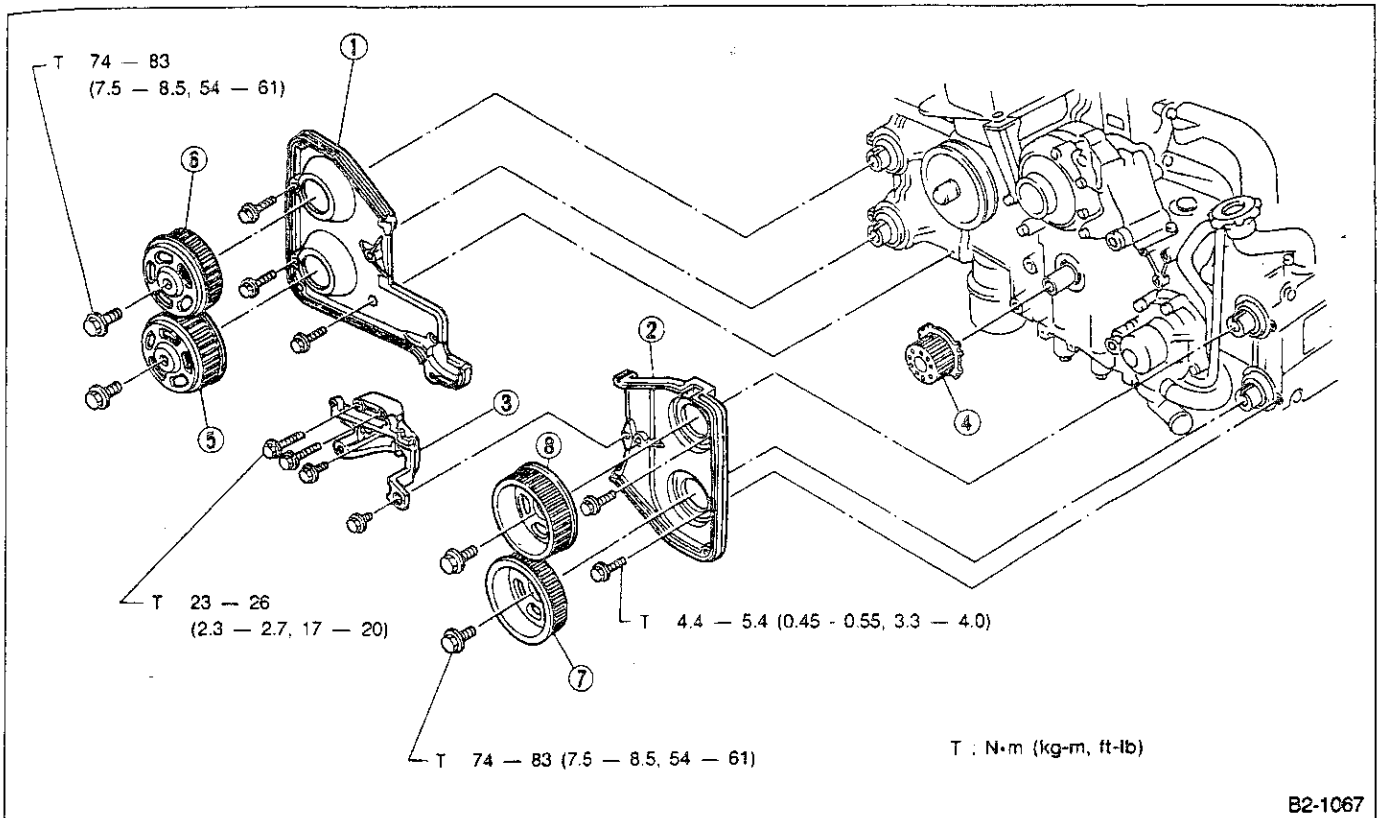
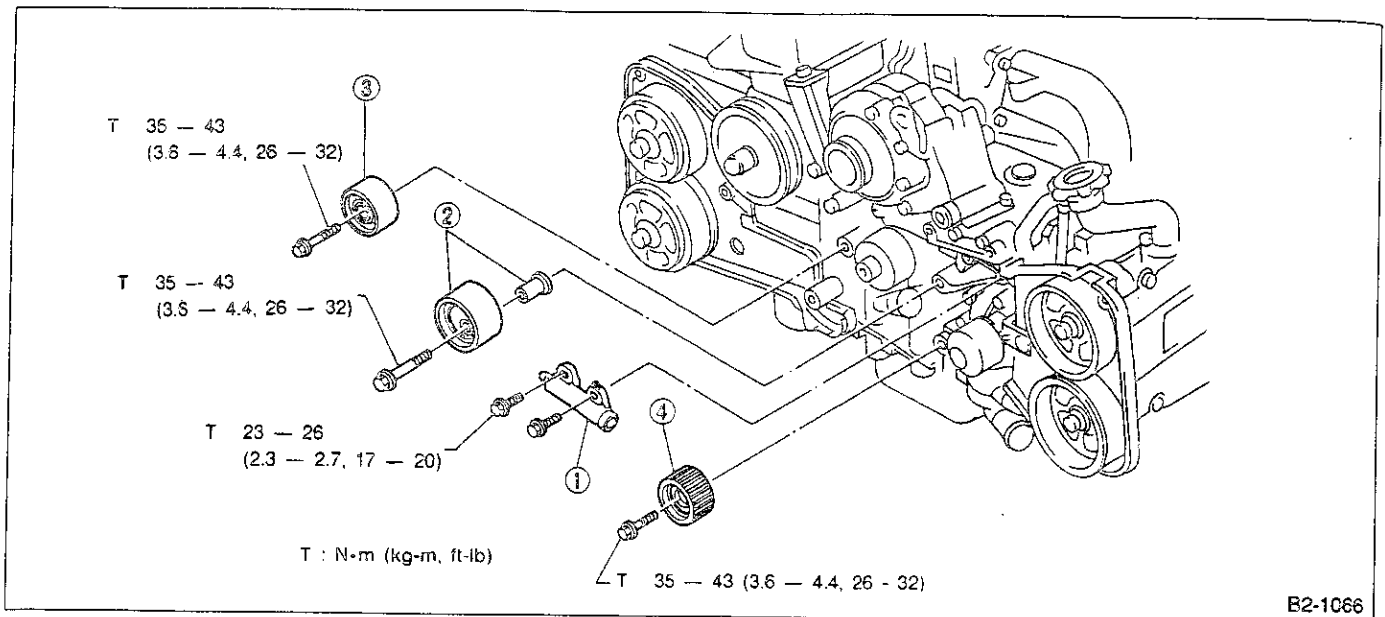
C: INSTALLATION**1. SPROCKET**

Fig. 26

- 1) Install right-hand belt cover No. 2.
- 2) Install left-hand belt cover No. 2.
- 3) Install tensioner bracket.
- 4) Install crankshaft sprocket.
- 5) Install right-hand exhaust camshaft sprocket. To lock camshaft, use CAMSHAFT SPROCKET WRENCH.
- 6) Install right-hand intake camshaft sprocket.
- 7) Install left-hand exhaust camshaft sprocket.
- 8) Install left-hand intake camshaft sprocket.

2. BELT TENSIONER AND IDLER



B2-1066

Fig. 27

1) Installation of belt tensioner adjuster.

(1) Insert stopper pin 1.5 mm (0.059 in) dia. into place while pushing tension adjuster rod into body using a press.

a. Do not allow press pressure to exceed 9,807 N (1,000 kg, 2,205 lb).

b. Do not release press pressure until stopper pin is completely inserted.

c. Push tension adjuster rod vertically.

(2) Temporarily tighten bolts while tension adjuster is pushed all the way to the right.

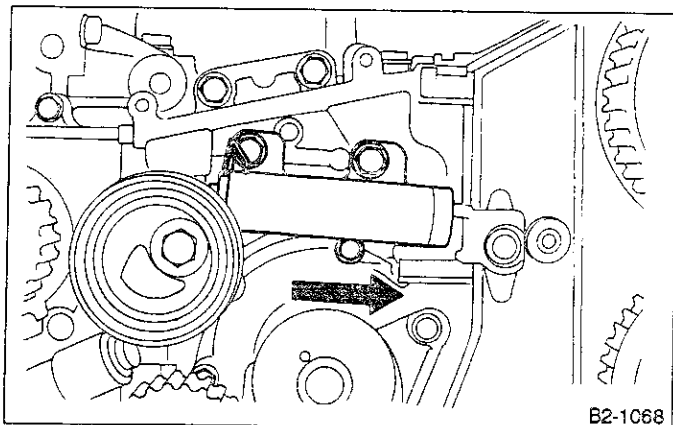


Fig. 28

2) Install belt tensioner.

3) Install belt idler.

4) Install belt idler No. 2.

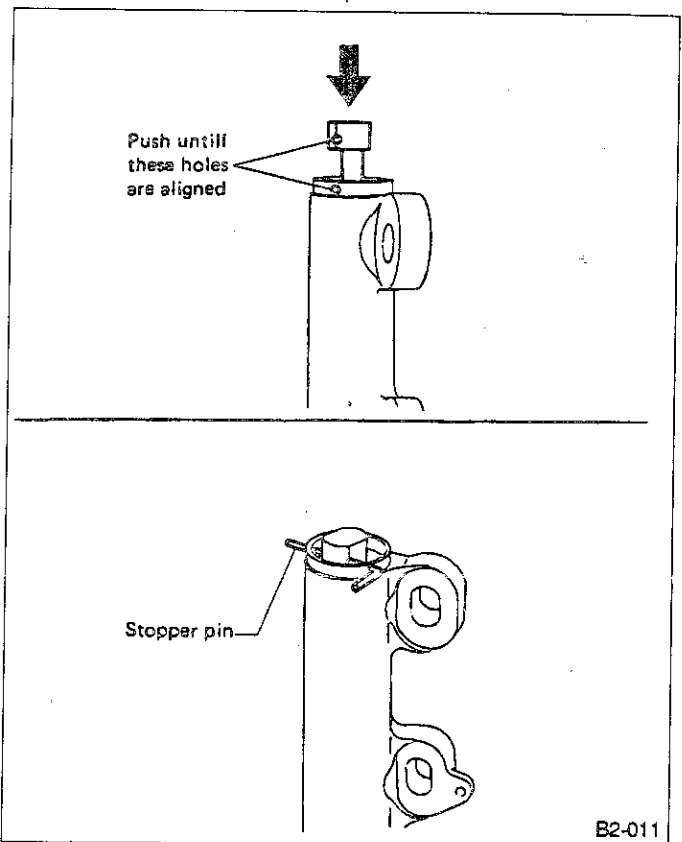


Fig. 29

3. TIMING BELT

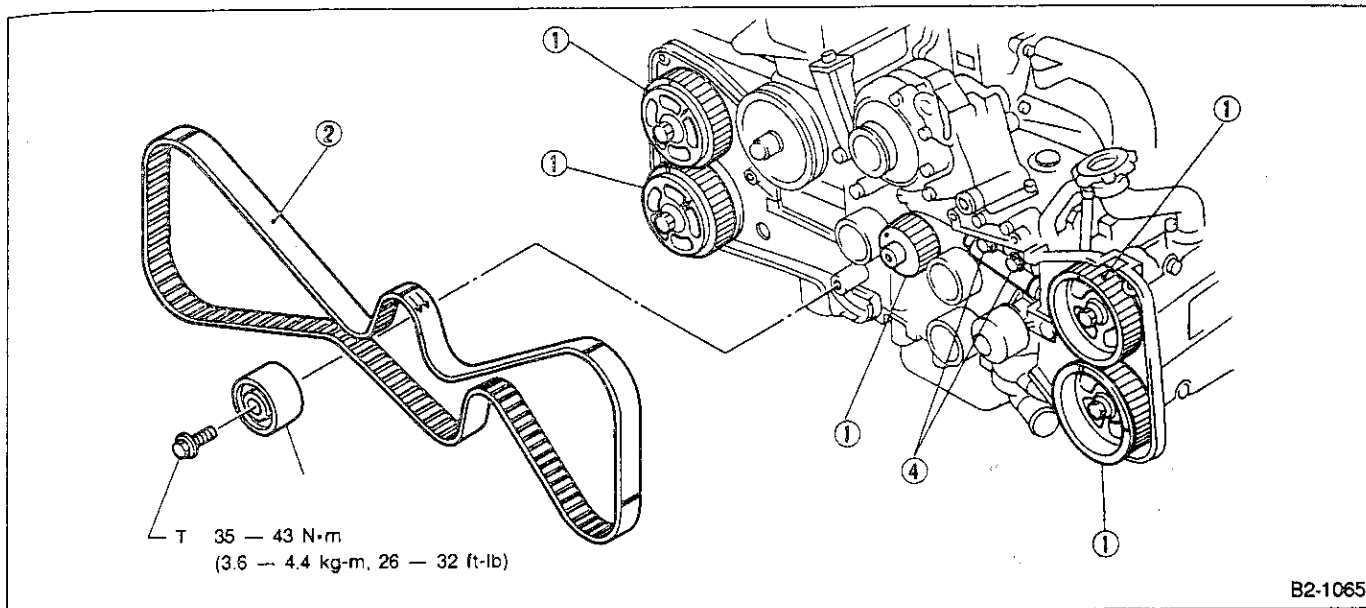


Fig. 30

1) Crankshaft and camshaft sprocket alignment

(1) Align mark on crankshaft sprocket with mark on the oil pump cover at cylinder block.

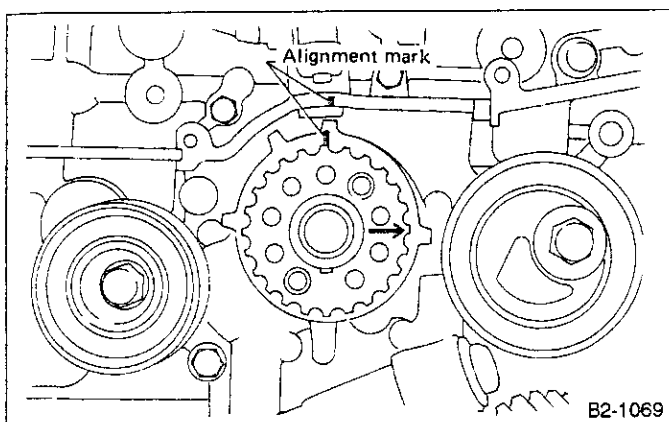


Fig. 31

(2) Align single-line mark on right-hand exhaust camshaft sprocket with notch on belt cover.

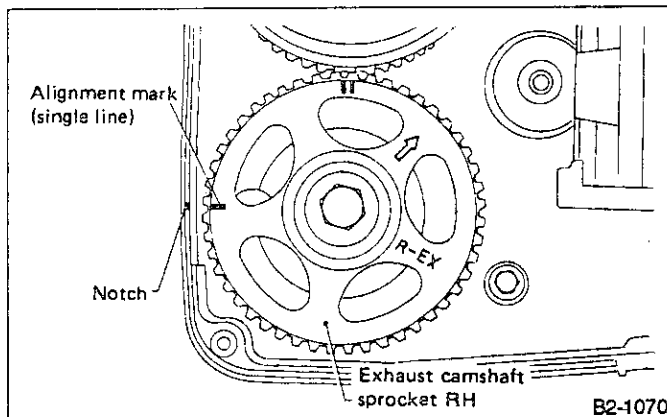


Fig. 32

(3) Align single-line mark on right-hand exhaust camshaft sprocket with notch on belt cover. (Make sure double lines on intake camshaft and exhaust camshaft sprockets are aligned.)

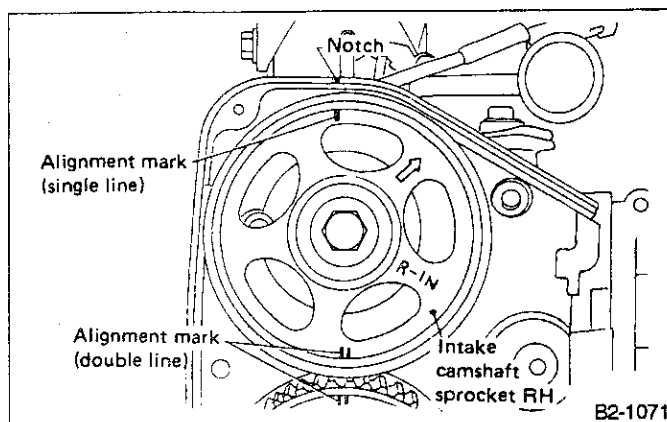


Fig. 33

(4) Align single-line mark on left-hand exhaust camshaft sprocket with notch on belt cover by turning sprocket counter clockwise (as viewed from front of engine).

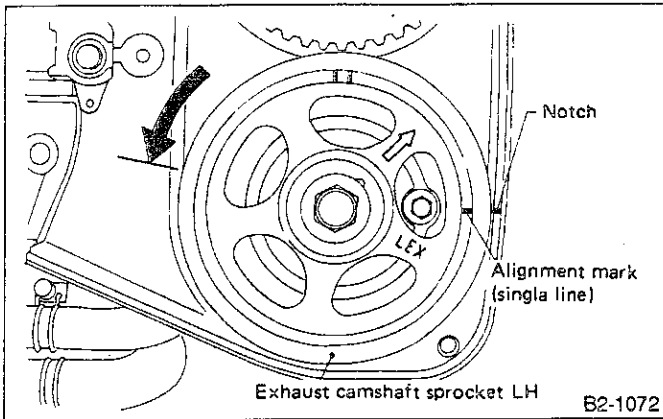


Fig. 34

(5) Align single-line mark on left-hand intake camshaft sprocket with notch on belt cover by turning sprocket clockwise (as viewed from front of engine). Ensure double lines on intake and exhaust camshaft sprockets are aligned.

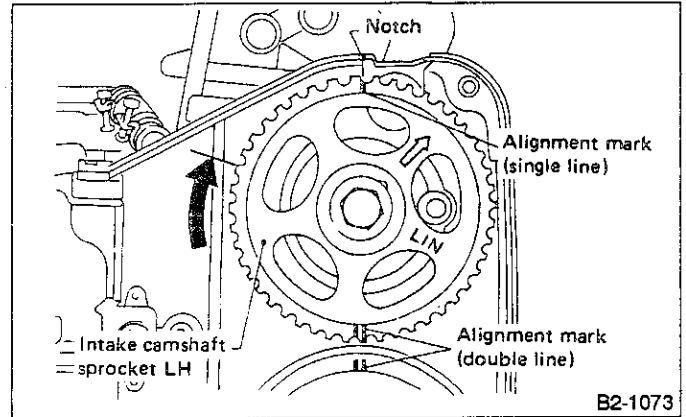


Fig. 35

(6) Ensure camshaft and crankshaft sprockets are positioned as shown.

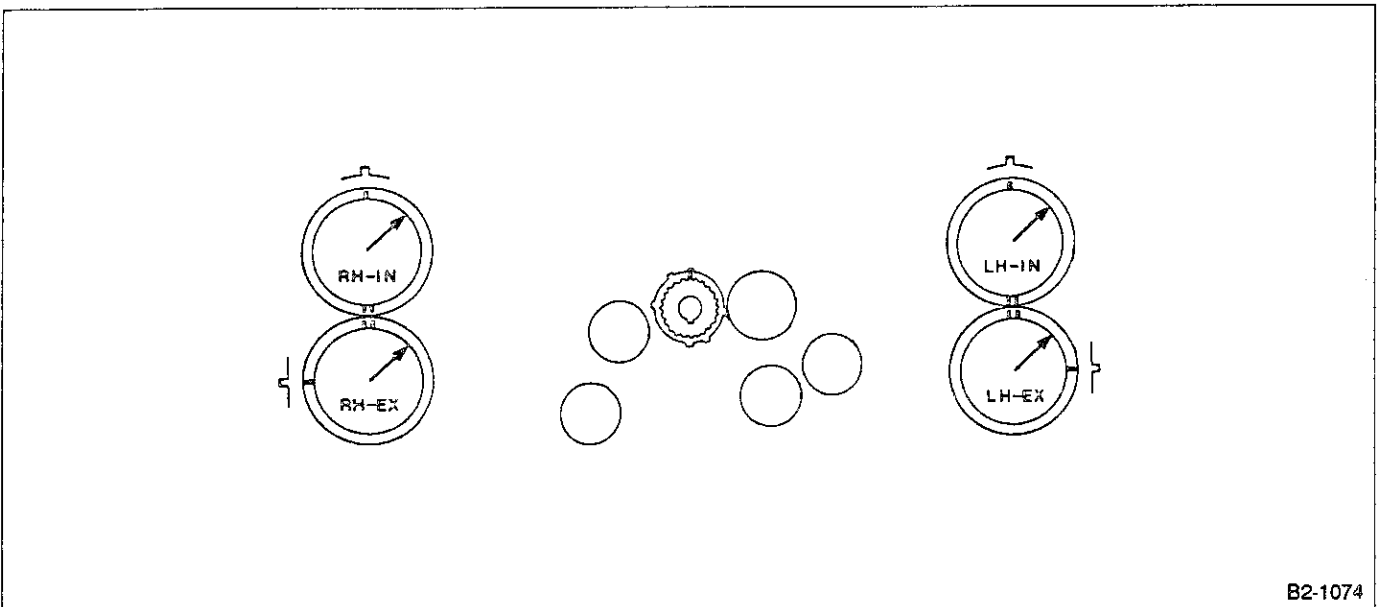


Fig. 36

Intake and exhaust camshafts for this DOHC engine can be independently rotated with timing belts removed. As can be seen from the following figure, if intake and exhaust valves are lifted simultaneously, their heads will interfere with each other, resulting in bent valves.

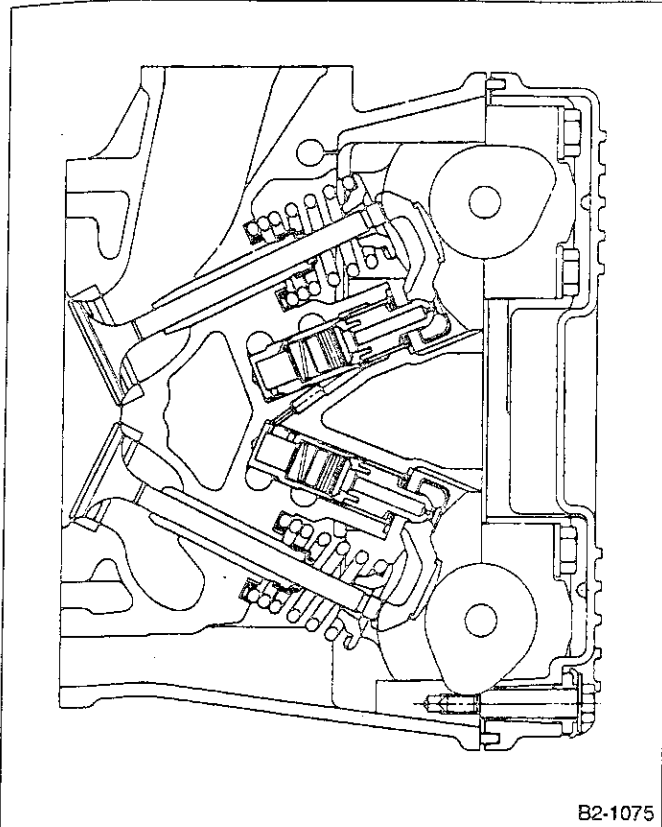


Fig. 37

• When timing belts are not installed, four camshafts are held at the "zero-lift" position, where all cams on camshafts do not push intake and exhaust valves down. (Under this condition, all valves remain unlifted.)

When camshafts are rotated to install timing belts, #2 intake- and #4 exhaust-cam of left-hand camshafts are held to push their corresponding valves down. (Under this condition, these valves are held lifted.) Right-side camshafts are held so that their cams do not push valves down.

Left-hand camshafts must be rotated from the "zero-lift" position to the position where timing belt is to be installed at as small an angle as possible, in order to prevent mutual interference of intake and exhaust valve heads.

Do not allow camshafts to rotate in the direction shown in the upper illustration in Figure 38 as this causes both intake and exhaust valves to lift simultaneously, resulting in interference with their heads.

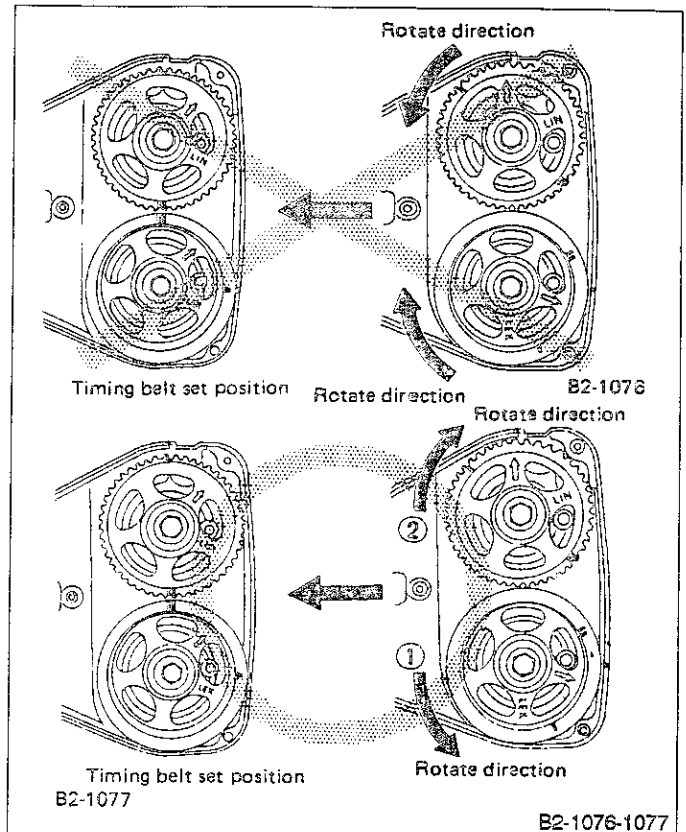


Fig. 38

2) Installation of timing belt.

(1) Align alignment mark on timing belt with marks on sprockets in the numerical order shown in Figure. While aligning marks, position timing belt properly.

Ensure belt's rotating direction is correct.

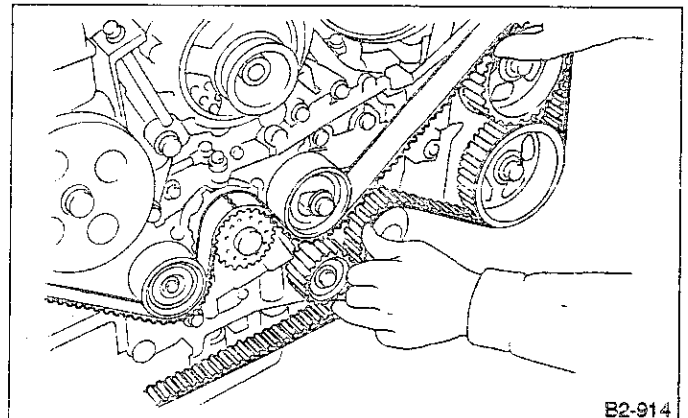


Fig. 39

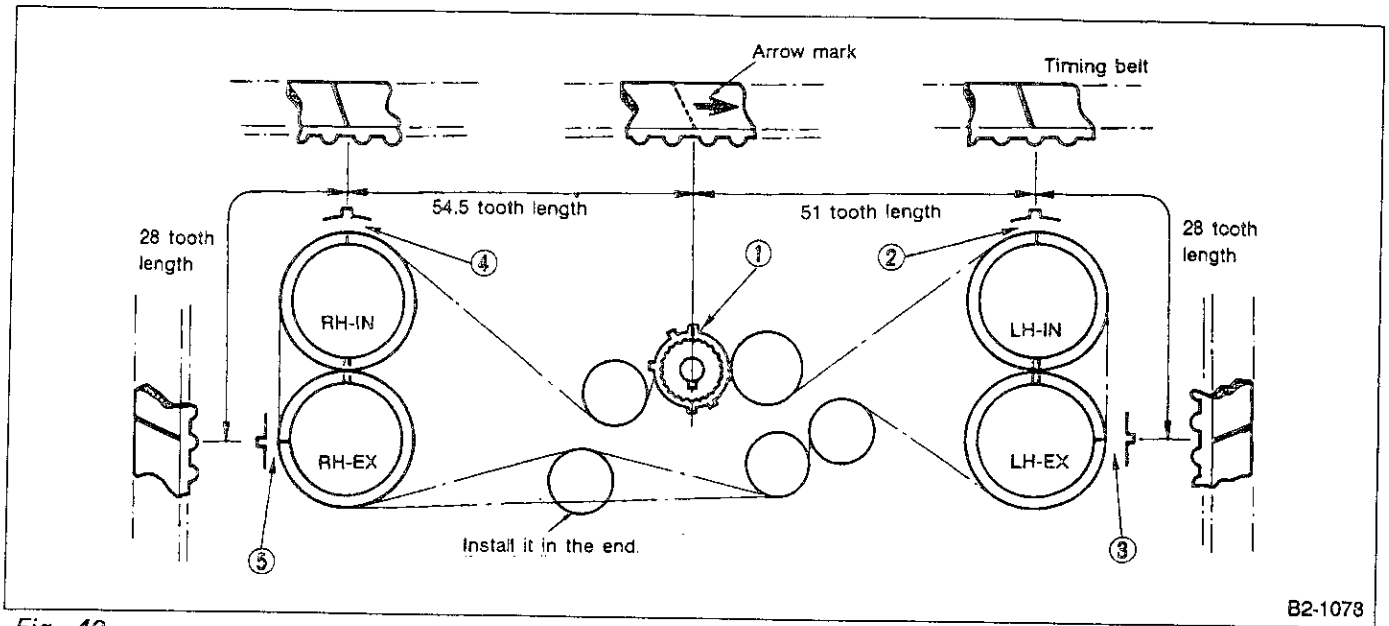


Fig. 40

3) Install belt idler.

4) Loosen tension adjuster attaching bolts and move adjuster all the way to the left. Tighten the bolts.

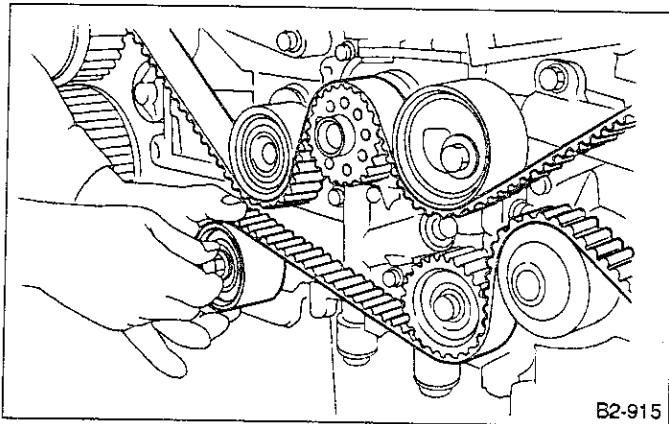


Fig. 41

Make sure that the marks on timing belt and sprockets are aligned.

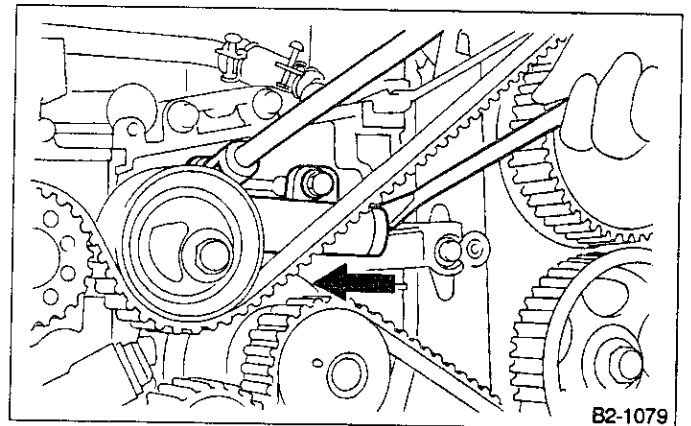


Fig. 42

5) After ensuring that the marks on timing belt and sprockets are aligned, remove stopper from tension adjuster.

After properly installing timing belt, remove rocker cover and ensure that the valve lash adjuster contains no air.

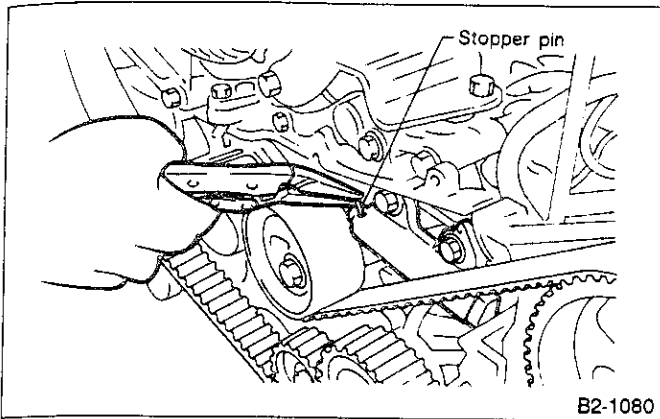


Fig. 43

4. CRANKSHAFT PULLEY AND BELT COVER

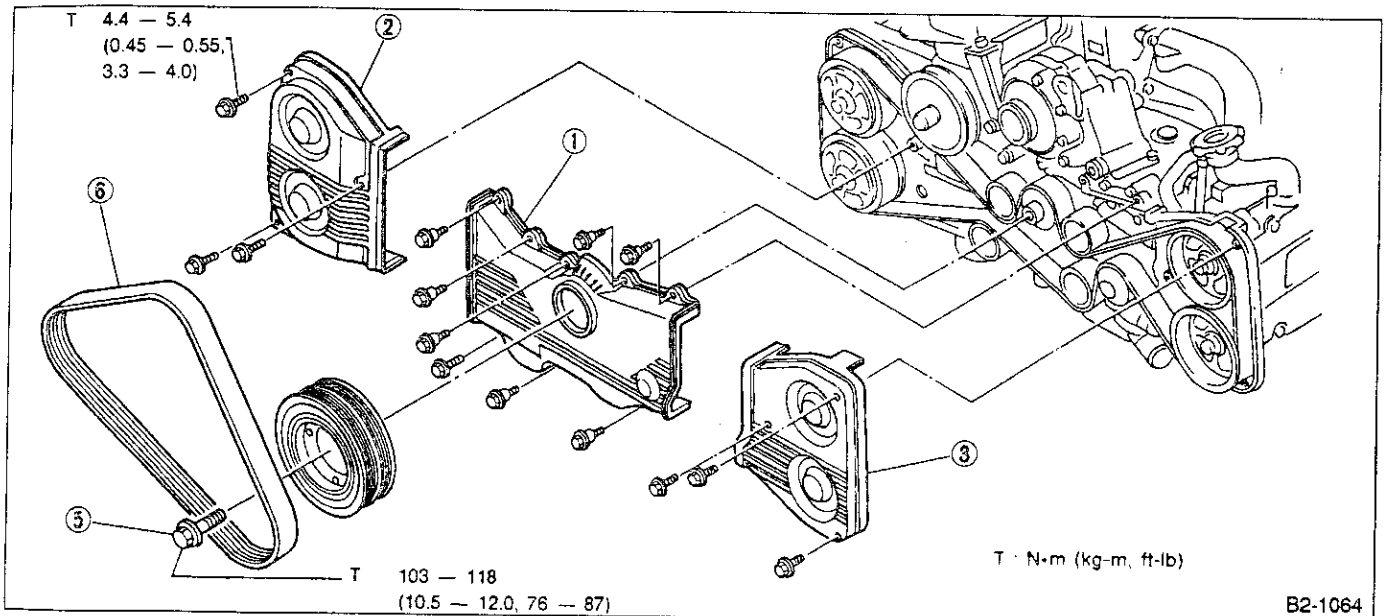


Fig. 44

- 1) Install front belt cover.
- 2) Install right-hand belt cover.
- 3) Install left-hand belt cover.
- 4) Install crankshaft pulley.
- 5) Install pulley bolt.
- 6) Install V-belt.

3. Camshaft

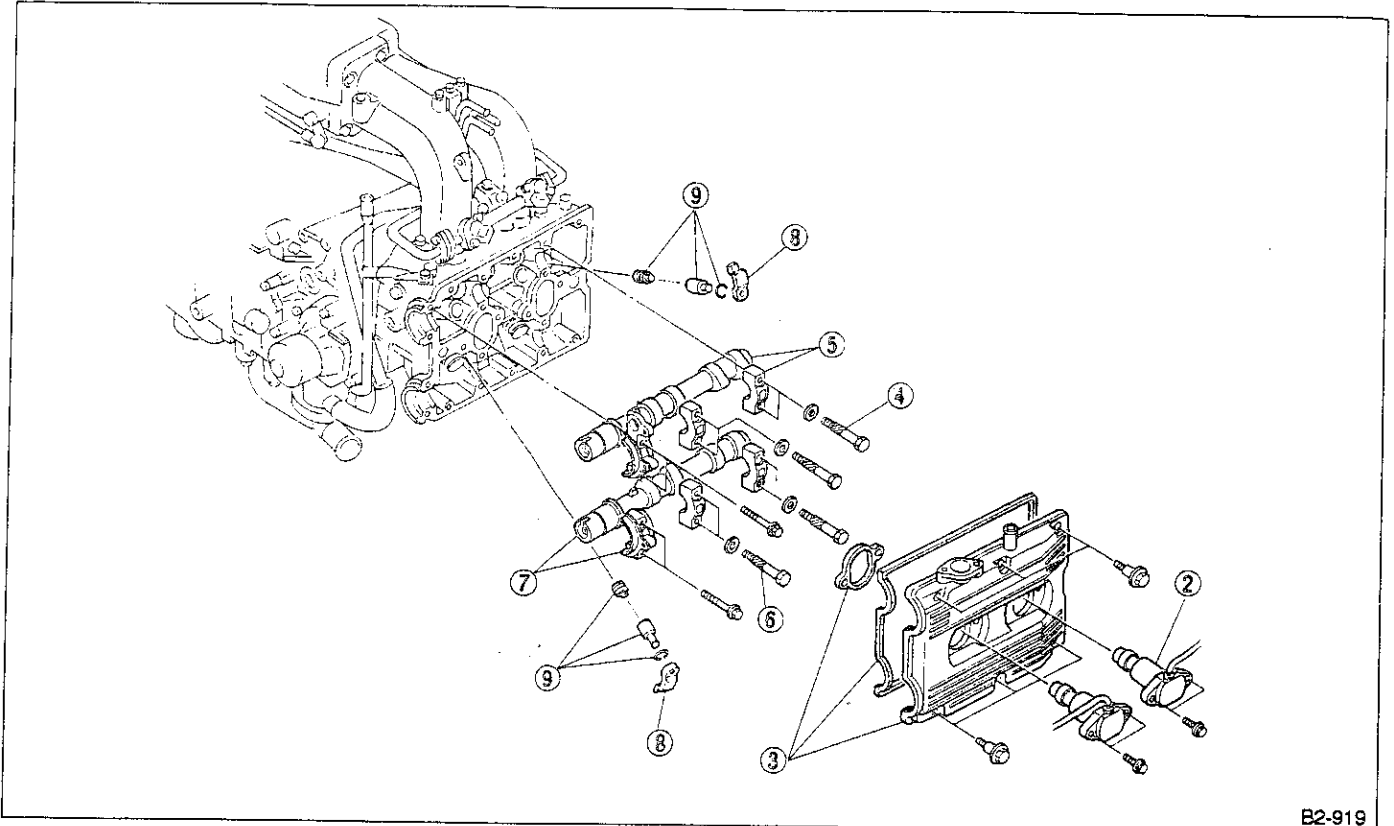
A: REMOVAL

2. CAMSHAFT LH

1. RELATED PARTS

1) Remove timing belt, camshaft sprockets and related parts.

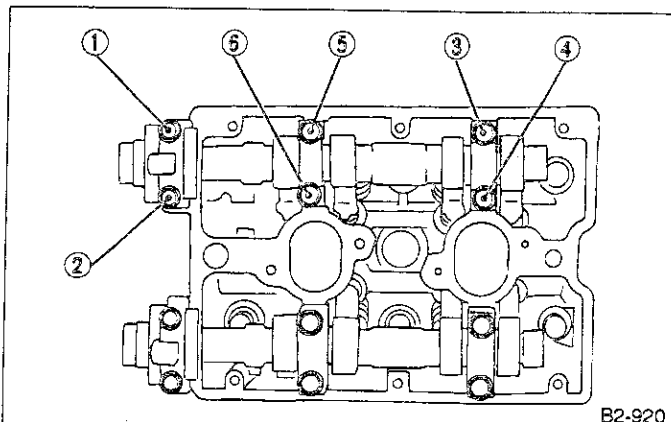
(Ref. to 2. Timing Belt [W2A0].)



B2-919

Fig. 45

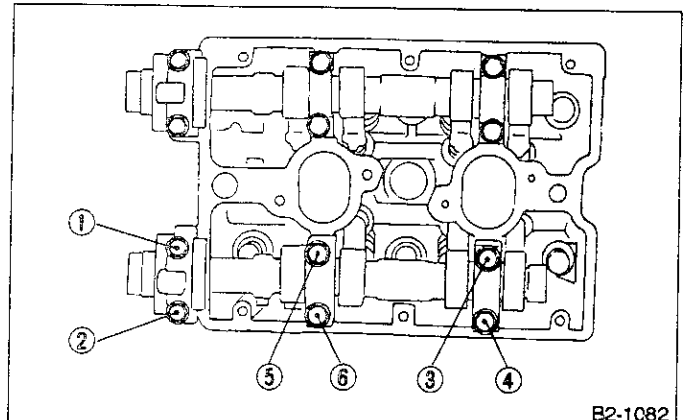
- 1) Remove cam-angle sensor.
- 2) Remove ignition coils.
- 3) Remove cylinder head cover and gasket.
- 4) Loosen intake camshaft cap bolts equally, a little at a time in the numerical sequence shown in Figure.



B2-920

Fig. 46

- 5) Remove camshaft caps and intake camshaft.
- 6) Loosen exhaust camshaft cap bolts equally, a little at a time in the numerical sequence shown in Figure.



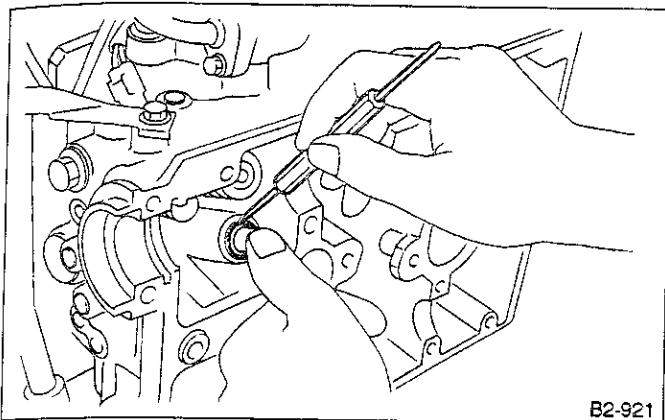
B2-1082

Fig. 47

7) Remove camshaft caps and exhaust camshaft. Arrange camshaft caps in order so that they can be installed in their original positions.

- 8) Remove valve rocker arms.
- 9) Removal of lash adjusters

(1) Remove circlips from pivots using tool with a fine point.



B2-921

Fig. 48

(2) Remove intake and exhaust pivots.

a. Arrange pivots in order so that they can be installed in their original positions.

b. Be careful not to confuse intake pivot with exhaust pivots. The diameter of exhaust pivot is larger 0.040 mm (0.0016 in) than that of intake pivot.

(3) Remove lash adjusters using tweezers and dip them in engine oil to prevent air entering.

10) Similarly, remove right-hand camshafts and related parts.

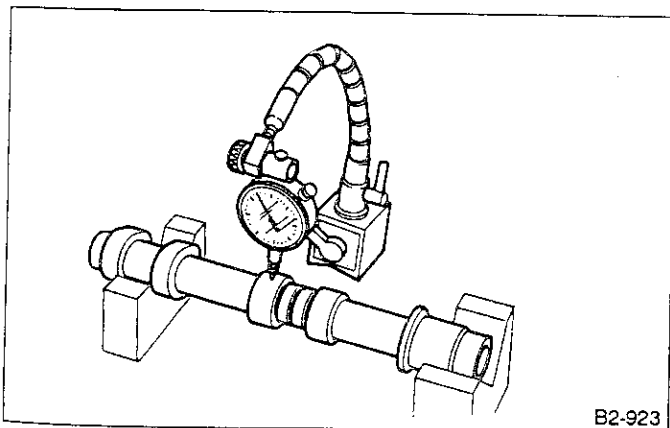
B: INSPECTION

1. CAMSHAFT

1) Measure the bend, and repair or replace if necessary.

Limit:

0.020 mm (0.0008 in)



B2-923

Fig. 49

2) Check journal for damage and wear. Replace if faulty.

3) Measure outside diameter of camshaft journal. If the journal diameter is not as specified, check the oil clearance.

	Camshaft journal	
	Front	Center, Rear
Standard	31.946 — 31.963 mm (1.2577 — 1.2584 in)	27.946 — 27.963 mm (1.1002 — 1.1009 in)

4) Measurement of the camshaft journal oil clearance

(1) Clean the bearing caps and camshaft journals.

(2) Place the camshafts on the cylinder head. (Without installing valve rocker.)

(3) Place plastigauge across each of the camshaft journals.

(4) Install the bearing caps.

(Refer to [W3C1].)

Do not turn the camshaft.

(5) Remove the bearing caps.

(6) Measure the widest point of the plastigauge on each journal.

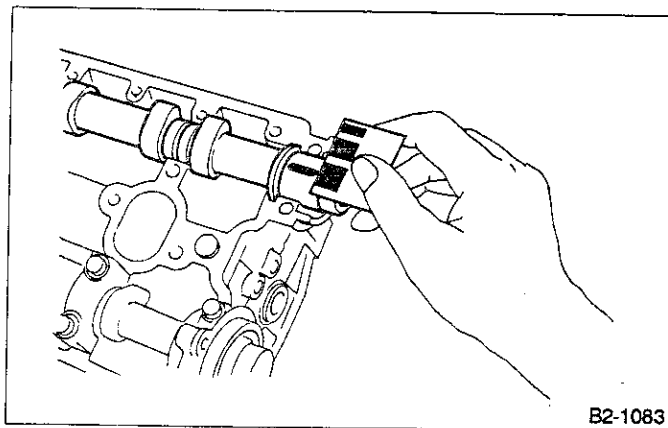
If the oil clearance exceeds the limit, replace the camshaft. If necessary, replace the camshaft caps and cylinder head as a set.

Standard oil clearance:

0.037 — 0.072 mm (0.0015 — 0.0028 in)

Limit:

0.10 mm (0.0039 in)



B2-1083

Fig. 50

(7) Completely remove the plastigauge.

5) Check cam face condition; remove minor faults by grinding with oil stone. Measure the cam height H; replace if the limit has been exceeded.

Unit: mm (in)

	Intake		Exhaust
	*1	*2	
Standard cam height: H	39.41 — 39.51 (1.5516 — 1.5555)	38.88 — 38.98 (1.5307 — 1.5346)	39.41 — 39.51 (1.5516 — 1.5555)
Wear limit	0.26 (0.0102)	0.28 (0.0110)	0.26 (0.0102)

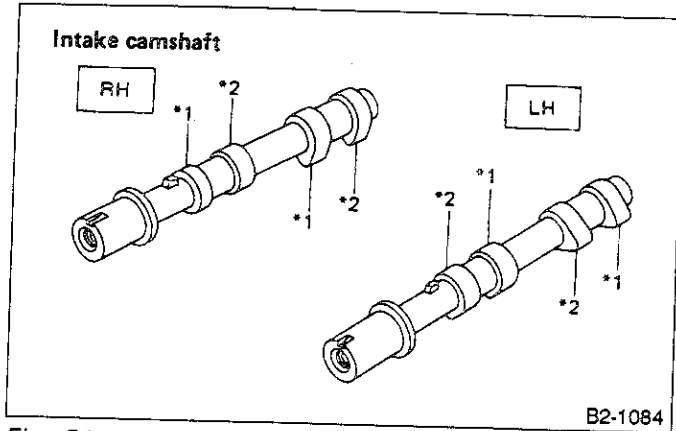


Fig. 51

B2-1084

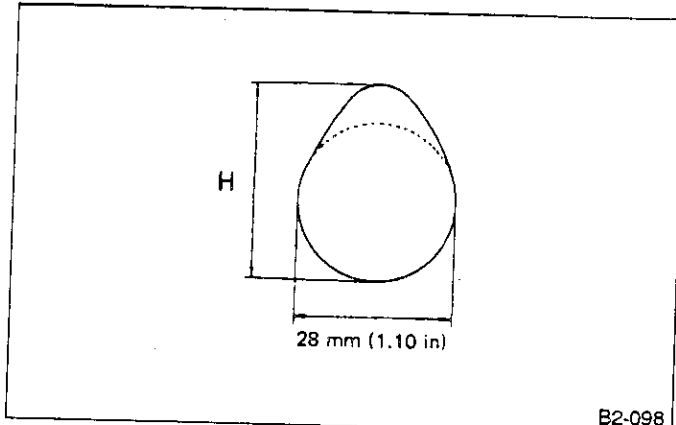


Fig. 52

B2-098

6) Measure the thrust clearance of camshaft with dial gauge. If the clearance exceeds the limit, replace caps and cylinder head as a set. If necessary replace camshaft.

Standard:

0.020 — 0.22 mm (0.0008 — 0.0087 in)

Limit: 0.35 mm (0.0138 in)

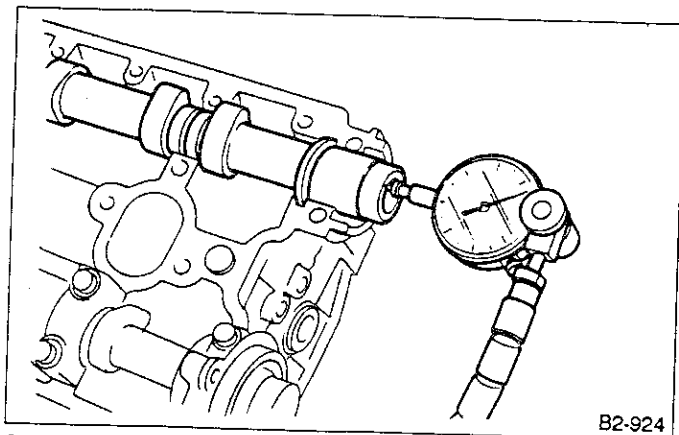


Fig. 53

B2-924

2. VALVE LASH ADJUSTER

1) Bleed air from valve lash adjuster as described below:

(1) While dipping valve lash adjuster in engine oil, as shown in Figure, push check ball in using a 2 mm (0.08 in) dia. round bar.

(2) With check ball pushed in, manually move plunger up and down at one-second intervals until air bubbles disappear.

(3) After air bubbles disappear, remove round bar and quickly push plunger in to ensure it is locked. If plunger does not lock properly, replace valve lash adjuster.

Leave lash adjuster (after air is bled) in engine oil until it is ready for installation.

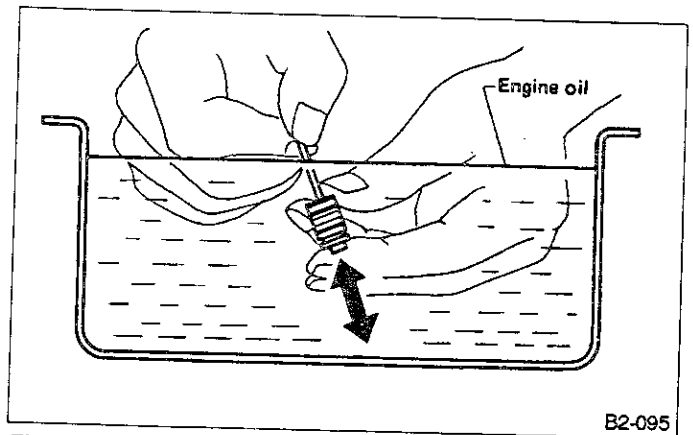


Fig. 54

B2-095

2) Replace valve lash adjuster with a new one if valve contact surface is scratched.

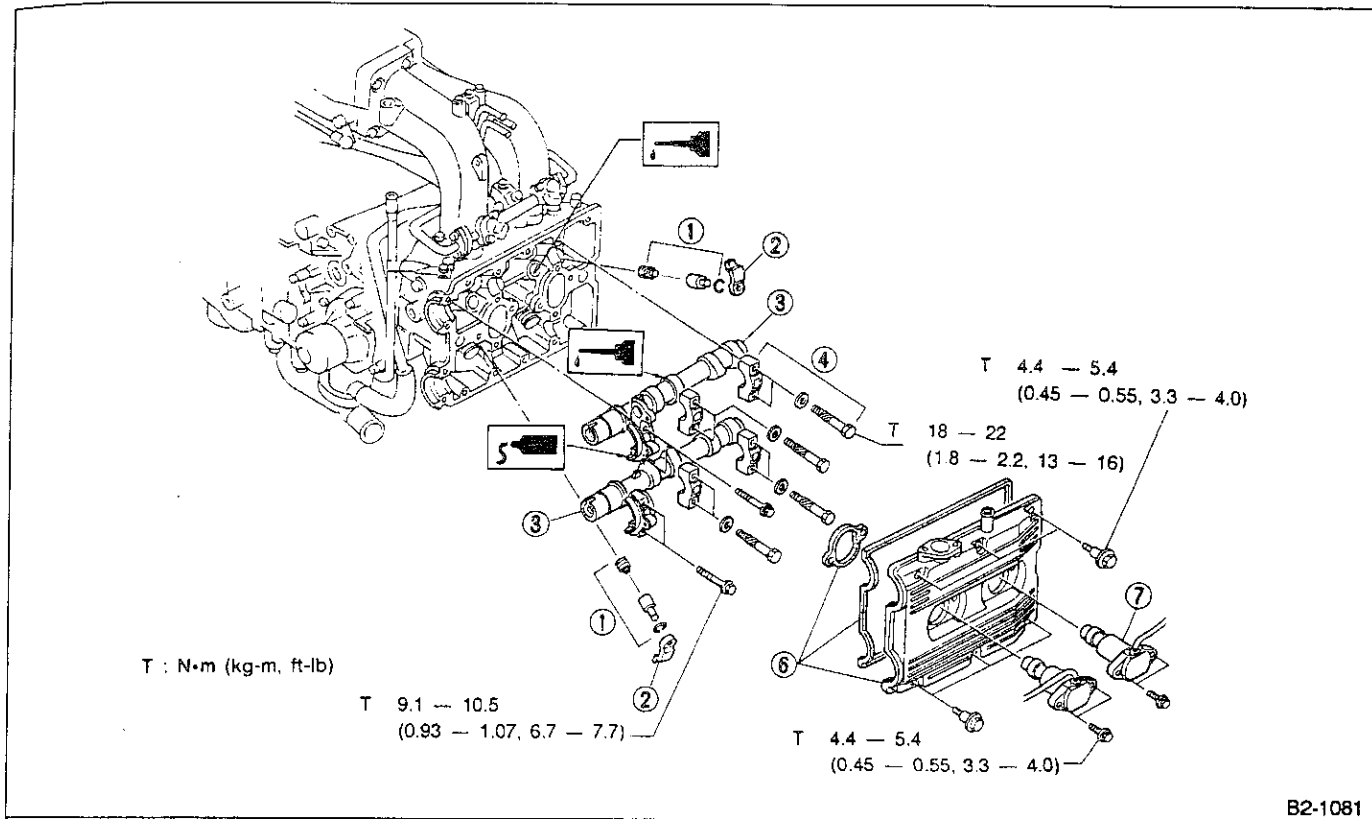
C: INSTALLATION**1. CAMSHAFT**

Fig. 55

1) Lash adjuster installation

(1) With cylinder head side facing upward, apply engine oil to sleeve (which accommodates lash adjuster) to at least the specified level.

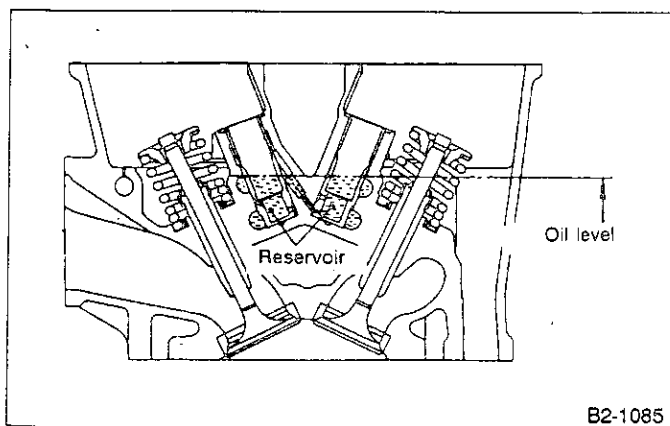


Fig. 56

Ensure cylinder head side faces upward during oil application as this prevents air from being sucked into adjuster pressure chamber after installing lash adjuster.

(2) Remove lash adjuster from container filled with engine oil, and install in cylinder head. Ensure air is not trapped in lash adjuster before installing.

(3) Install pivot in sleeve and secure with circlip. [Pivot designs differ for intake and exhaust valves; pivot for exhaust valve is approximately 0.04 mm (0.0016 in) larger in diameter than that for intake valve.]

2) Valve rocker installation

Position one end of rocker arm on pivot and the other end on valve stem end.

3) Camshaft installation

Apply engine oil to cylinder head at camshaft bearing location before installing camshaft. Install camshaft so that rocker arm is close to or in contact with "base circle" of cam lobe.

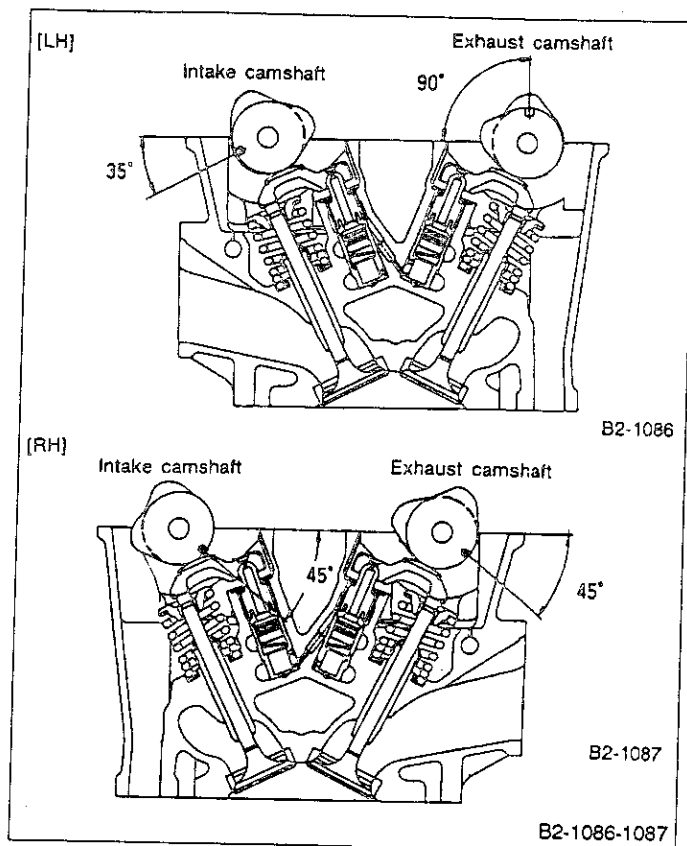


Fig. 57

When camshafts are positioned as shown in Figure 57, camshafts need to be rotated at a minimum to align with timing belt during installation.

Right-hand camshaft need not be rotated when set at position shown above.

Left-hand intake camshaft: Rotate 30° clockwise.

Left-hand exhaust camshaft: Rotate 45° counter-clockwise.

4) Camshaft cap installation

- (1) Apply fluid packing sparingly to cap mating surface.

Do not apply fluid packing excessively. Failure to do so may cause excess packing to come out and flow toward oil seal, resulting in oil leaks.

Fluid packing:

Three-bond 1215 or equivalent

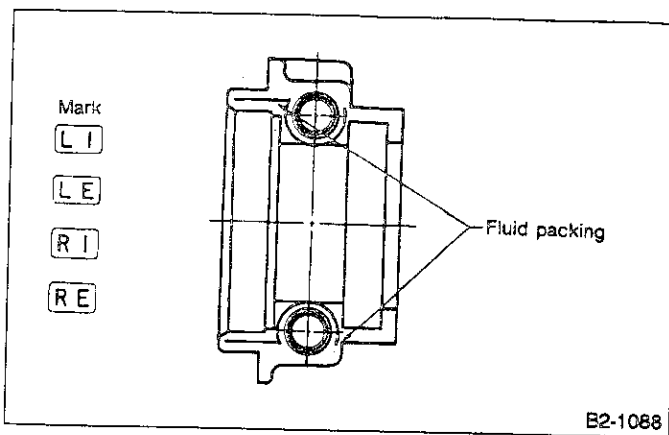


Fig. 58

- (2) Apply engine oil to cap bearing surface and install cap on camshaft as shown by identification mark.

- (3) Gradually tighten cap in at least two stages in the numerical order shown in Figure 59, and then tighten to specified torque.

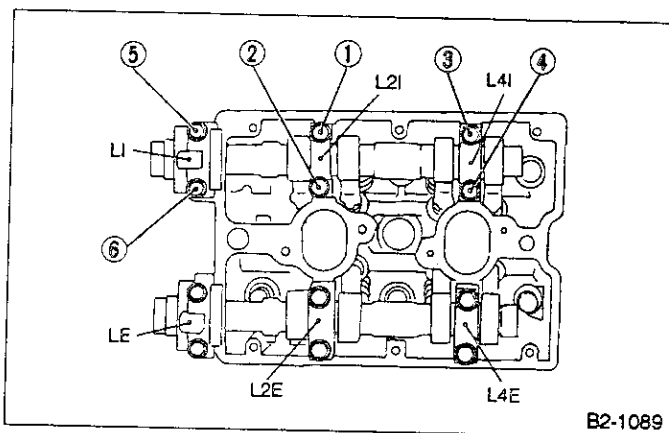


Fig. 59

- (4) Similarly, tighten cap on exhaust side. After tightening cap, ensure camshaft rotates only slightly while holding it at "base" circle.

5) Camshaft oil seal installation

- (1) Apply grease to new oil seal lips and press onto front end of camshaft.

Use a new oil seal.

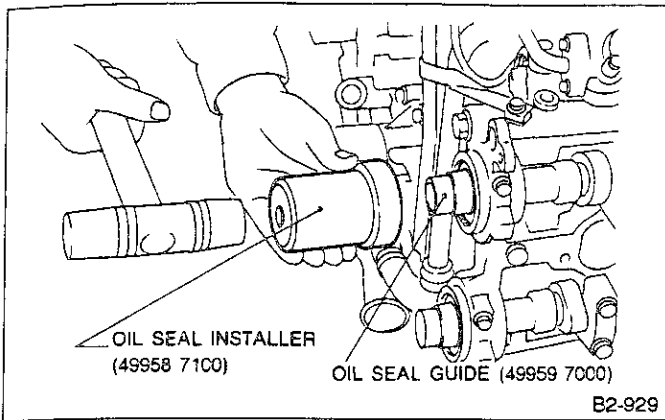


Fig. 60

6) Rocker cover installation

- (1) Install gasket on rocker cover. Install peripheral gasket and ignition coil gasket.
- (2) Apply fluid packing to four front open edges of peripheral gasket.

Fluid packing:

Three-bond 1215 or equivalent

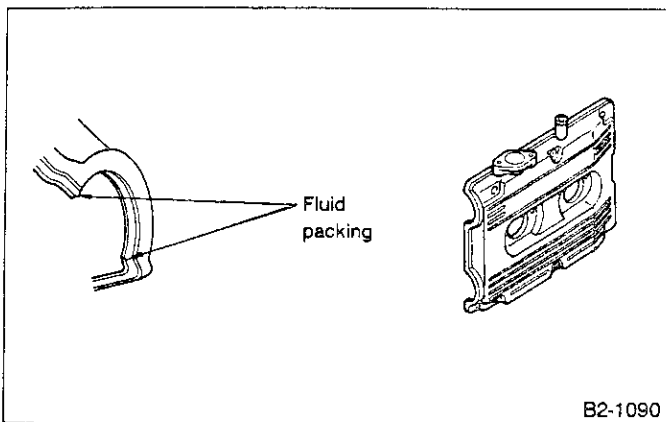


Fig. 61

- (3) Install rocker cover on cylinder head. Ensure gasket is properly positioned during installation.

- 7) Install ignition coil.
- 8) Install cam angle sensor.
- 9) Similarly, install parts on right-hand side.

2. RELATED PARTS

- 1) Install timing belt, camshaft sprockets and related parts.

(Ref. to 2. Timing Belt [W2C0].)

4. Cylinder Head

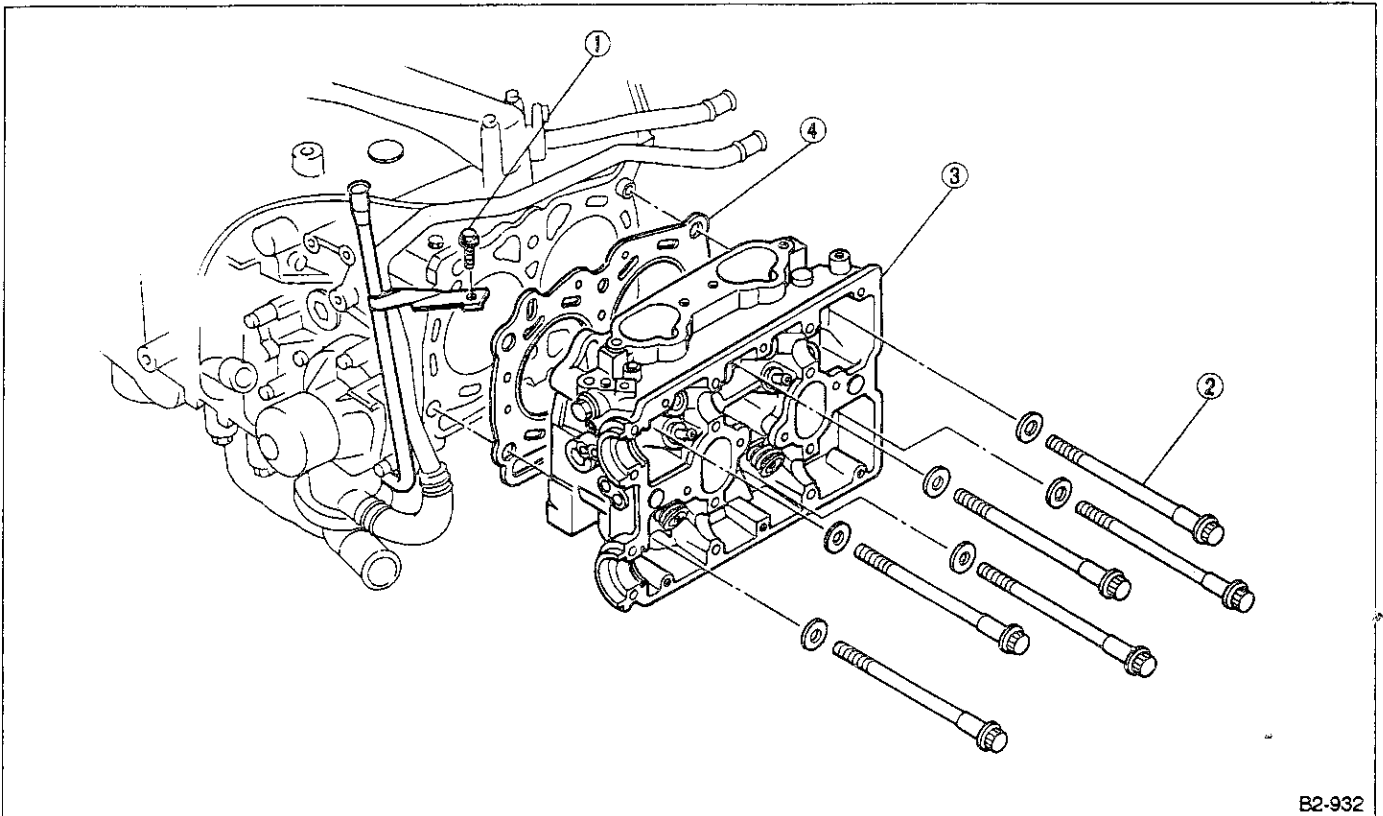
A: REMOVAL

1. INTAKE MANIFOLD

- 1) Remove V-belt.
- 2) Remove power steering pump.
- 3) Remove alternator, air conditioner compressor and brackets.
- 4) Remove hoses and tubes from cylinder block.

2. CYLINDER HEAD

- 5) Disconnect each connector and/or remove connector bracket.
- 6) Remove crank angle sensor, cam angle sensor and knock sensor.
- 7) Remove coolant filler tank.
- 8) Remove intake manifold ASSY and gasket.
- 9) Remove water pipe.
- 10) Remove timing belt, camshaft sprockets and related parts.
(Refer to 2. Timing Belt [W2A0].)
- 11) Remove rocker cover, camshafts and related parts.
(Refer to 3. Camshaft [W3A0].)



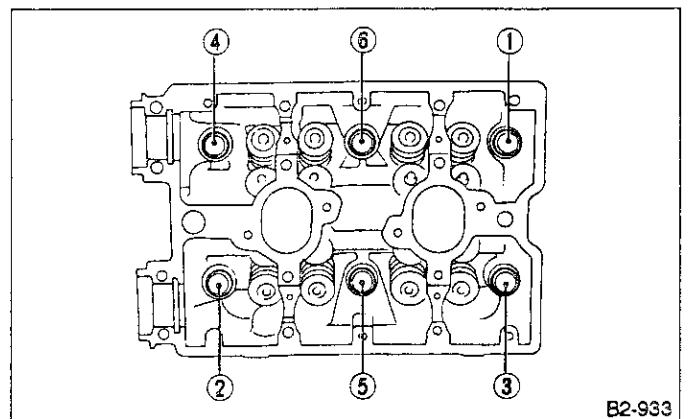
B2-932

Fig. 62

- 1) Remove oil level gauge guide attaching bolt (left hand only).
- 2) Remove cylinder head bolts in numerical sequence shown in Figure.

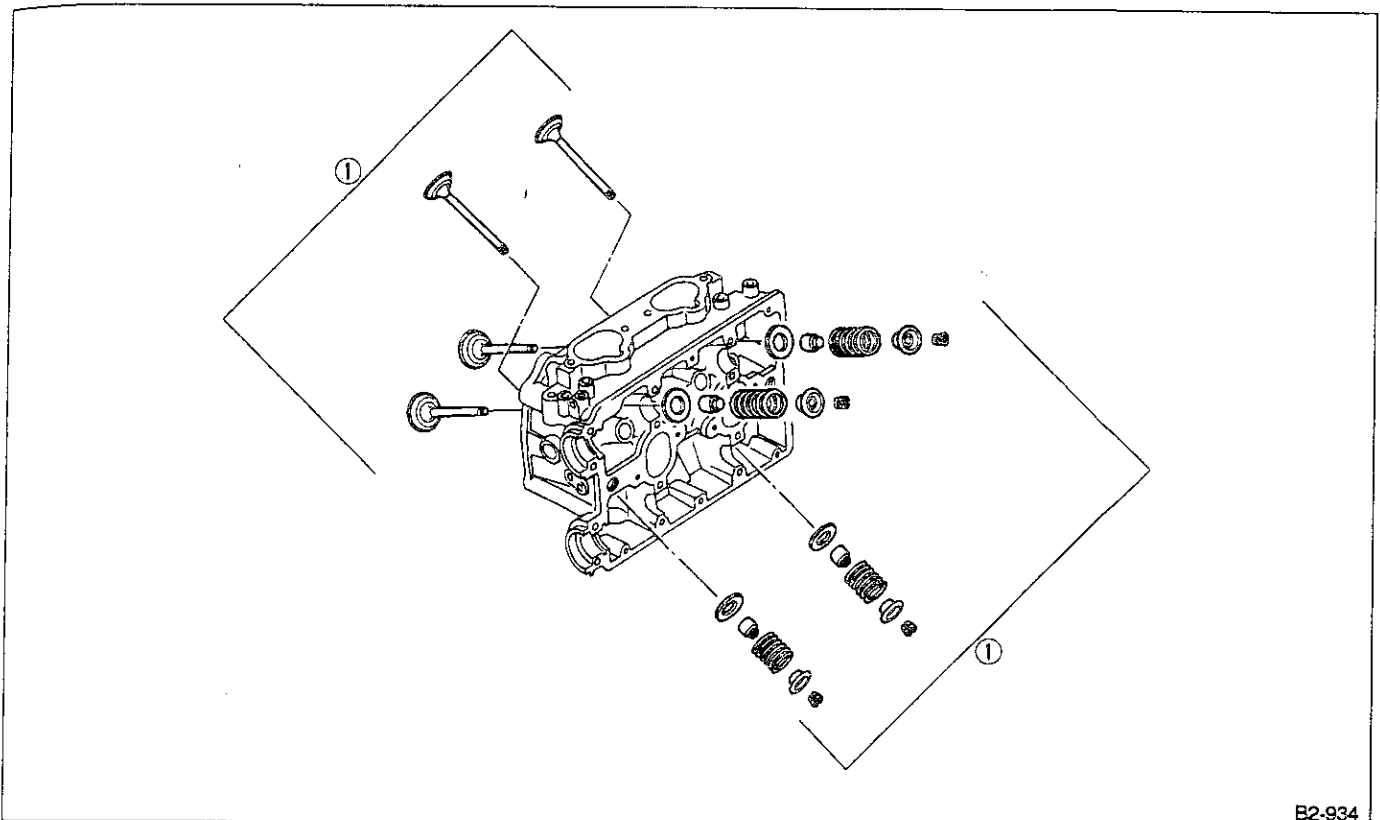
Leave bolts ① and ④ engaged by three or four threads to prevent cylinder head from falling.

- 3) While tapping cylinder head with a plastic hammer, separate it from cylinder block. Remove bolts ① and ④ to remove cylinder head.
- 4) Remove cylinder head gasket.
- 5) Similarly, remove right-hand cylinder head.



B2-933

Fig. 63

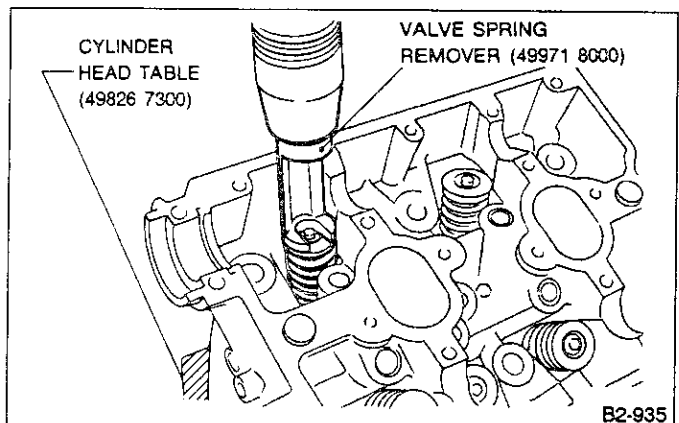
B: DISASSEMBLY

B2-934

Fig. 64

1) Compress the valve spring and remove the valve spring retainer key. Remove each valve and valve spring.

- a. Mark each valve to prevent confusion.
- b. Use extreme care not to damage the lips of the intake valve oil seals and exhaust valve oil seals.



B2-935

Fig. 65

C: INSPECTION**1. CYLINDER HEAD**

- 1) Make sure that no crack or other damage exists. In addition to visual inspection, inspect important areas by means of red check.
- 2) Measure the warping of the cylinder head surface that mates with crankcase by using a straight edge and thickness gauge.

If the warping exceeds 0.05 mm (0.0020 in), regrind the surface with a surface grinder.

Warping limit:

0.05 mm (0.0020 in)

Grinding limit:

0.3 mm (0.012 in)

Standard height of cylinder head:

127.5 mm (5.020 in)

Uneven torque for the cylinder head nuts can cause warping. When reassembling, pay special attention to the torque so as to tighten evenly.

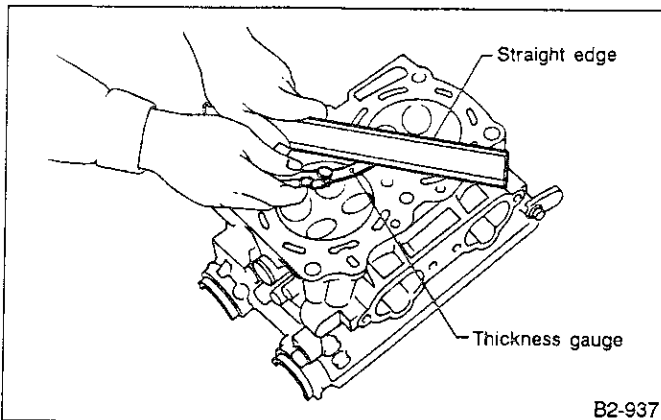


Fig. 66

2. VALVE SEAT

Inspect intake and exhaust valve seats, and correct the contact surfaces with valve seat cutter if they are defective or when valve guides are replaced.

W:

Intake

Standard

1.0 mm (0.039 in)

Limit

1.7 mm (0.067 in)

Exhaust

Standard

1.5 mm (0.059 in)

Limit

2.2 mm (0.087 in)

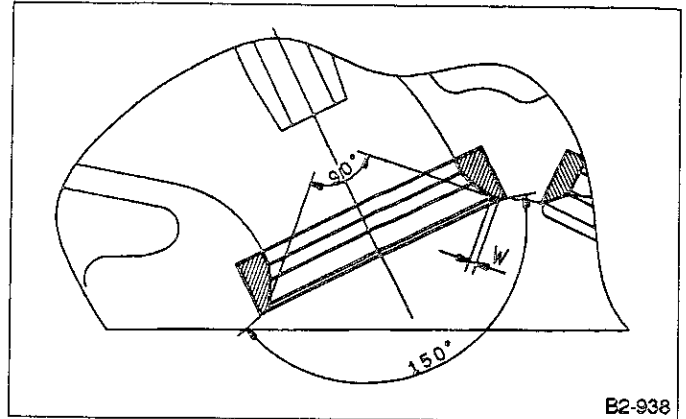


Fig. 67

3. VALVE GUIDE

1) Check the clearance between valve guide and stem. The clearance can be checked by measuring the outside diameter of valve stem and the inside diameter of valve guide with outside and inside micrometers respectively.

Clearance between the valve guide and valve stem:

Standard

Intake

0.035 — 0.062 mm (0.0014 — 0.0024 in)

Exhaust

0.040 — 0.067 mm (0.0016 — 0.0026 in)

Limit

0.15 mm (0.0059 in)

Valve guide inner diameters:

6.600 — 6.615 mm (0.2598 — 0.2604 in)

Valve stem outer diameter:

Intake

6.550 — 6.565 mm (0.2579 — 0.2585 in)

Exhaust

6.560 — 6.565 mm (0.2583 — 0.2585 in)

2) If the clearance between valve guide and stem exceeds the specification, replace guide as follows:

- (1) Place cylinder head on CYLINDER HEAD TABLE with the combustion chamber upward so that valve guides enter the holes in CYLINDER HEAD TABLE.
- (2) Insert VALVE GUIDE REMOVER into valve guide and press it down to remove valve guide.

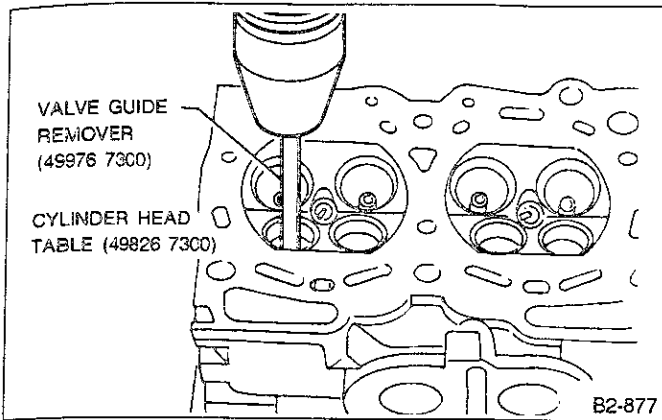


Fig. 68

(3) Turn cylinder head upside down and place VALVE GUIDE ADJUSTER as shown in the figure.

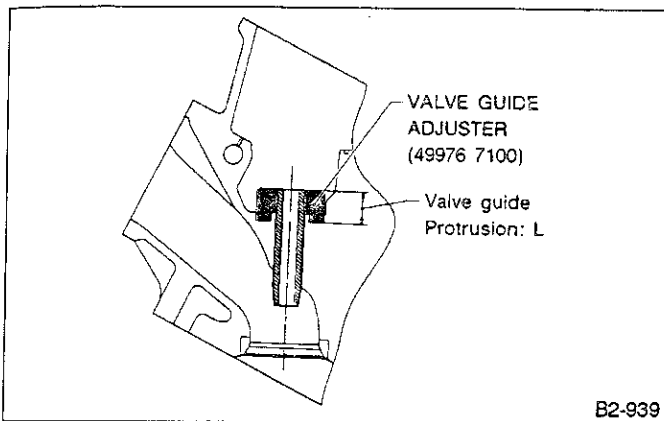


Fig. 69

(4) Before installing new valve guide, make sure that neither scratches nor damages exist on the inside surface of the valve guide holes in cylinder head.

(5) Put new valve guide, coated with sufficient oil, in cylinder, and insert VALVE GUIDE REMOVER into valve guide. Press in until the valve guide upper end is flush with the upper surface of VALVE GUIDE ADJUSTER.

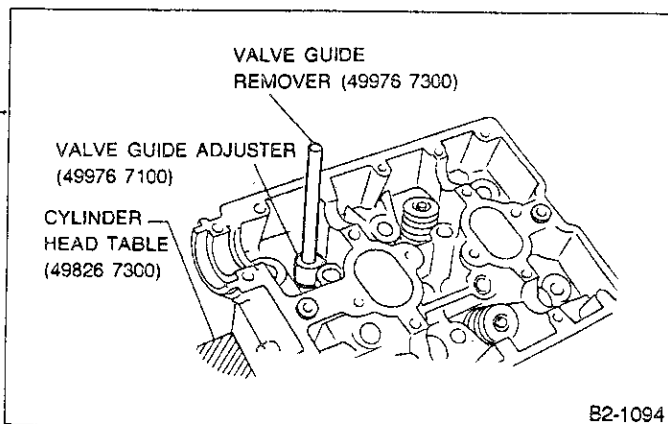


Fig. 70

(6) Check the valve guide protrusion.

Valve guide protrusion: L
13.3 — 13.7 mm (0.524 — 0.539 in)

(7) Ream the inside of valve guide with VALVE GUIDE REAMER (499767500). Gently rotate the reamer clockwise while pressing it lightly into valve guide, and return it also rotating clockwise. After reaming, clean valve guide to remove chips.

- Apply engine oil to the reamer when reaming.
- If the inner surface of the valve guide is torn, the edge of the reamer should be slightly ground with an oil stone.
- If the inner surface of the valve guide becomes lustrous and the reamer does not chip, use a new reamer or remedy the reamer.

(8) Recheck the contact condition between valve and valve seat after replacing valve guide.

4. INTAKE AND EXHAUST VALVE

1) Inspect the flange and stem of valve, and replace if damaged, worn, or deformed, or if "H" is less than the specified limit.

H:

Intake

Standard

1.2 mm (0.047 in)

Limit

0.8 mm (0.031 in)

Exhaust

Standard

1.5 mm (0.059 in)

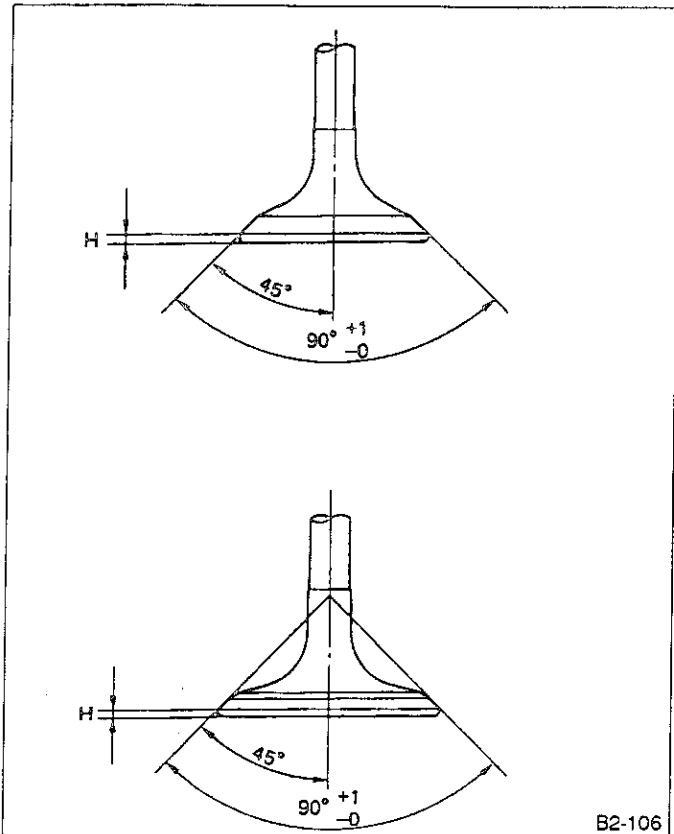
Limit

0.8 mm (0.031 in)

Valve overall length:

Intake 97.97 mm (3.8571 in)

Exhaust 97.57 mm (3.8413 in)



B2-106

Fig. 71

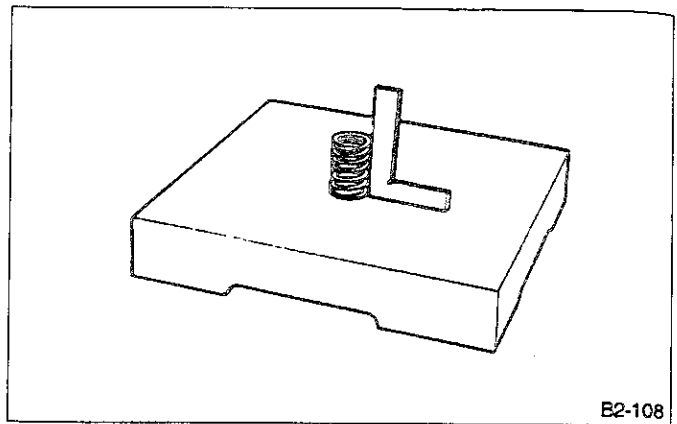
2) Put a small amount of grinding compound on the seat surface and lap the valve and seat surface. Also refer to Cylinder Head 3) at this time. Install a new intake valve oil seal after lapping.

5. VALVE SPRINGS

1) Check valve springs for damage, free length, and tension. Replace valve spring if it is not to the specifications presented below.

2) To measure the squareness of the valve spring, stand the spring on a surface plate and measure its deflection at the top using a try square.

Free length	40.7 mm (1.602 in)
Tension/spring height	163.8 — 188.3 N (16.7 — 19.2 kg, 36.8 — 42.3 lb)/ 35.0 mm (1.378 in)
	473.7 — 524.7 N (48.3 — 53.5 kg, 106.5 — 118.0 lb)/ 27.0 mm (1.063 in)
Squareness	2.5°, 1.8 mm (0.071 in)



B2-108

Fig. 72

6. INTAKE AND EXHAUST VALVE OIL SEAL

Replace oil seal with new one, if lip is damaged or spring out of place, or when the surfaces of intake valve and valve seat are reconditioned or intake valve guide is replaced.

Press in oil seal to the specified dimension indicated in the figure, using OIL SEAL INSTALLER.

- Apply engine oil to oil seal before force-fitting.
- Differentiate between intake valve oil seal and exhaust valve oil seal by noting their difference in color.

Color of rubber part:

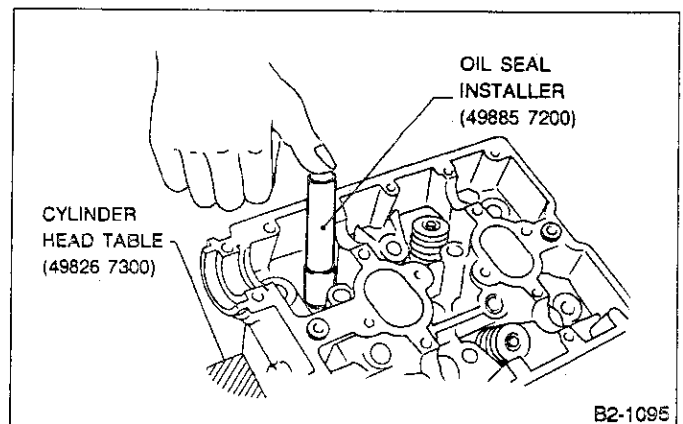
Intake [Black]

Exhaust [Brown]

Color of spring part:

Intake [Black]

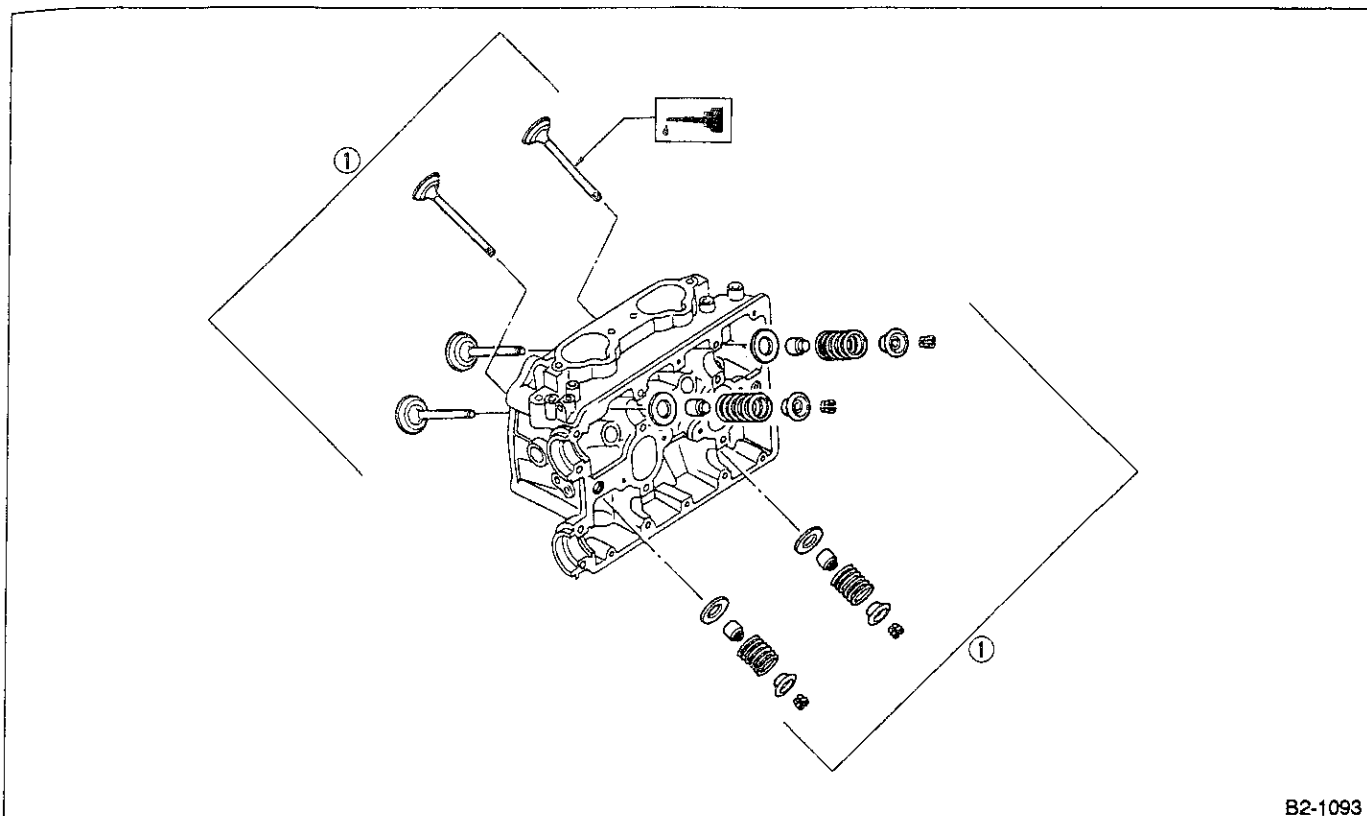
Exhaust [Black]



B2-109E

Fig. 73

D: ASSEMBLY



B2-1093

Fig. 74

1) Installation of valve spring and valve.

(1) Coat stem of each valve with engine oil and insert valve into valve guide.

When inserting valve into valve guide, use special care not to damage the oil seal lip.

(2) Install valve spring and retainer.

Be sure to install the valve springs with their close-coiled end facing the seat on the cylinder head.

(3) Compress valve spring and fit valve spring retainer key.

(4) After installing, tap valve spring retainers lightly with wooden hammer for better seating.

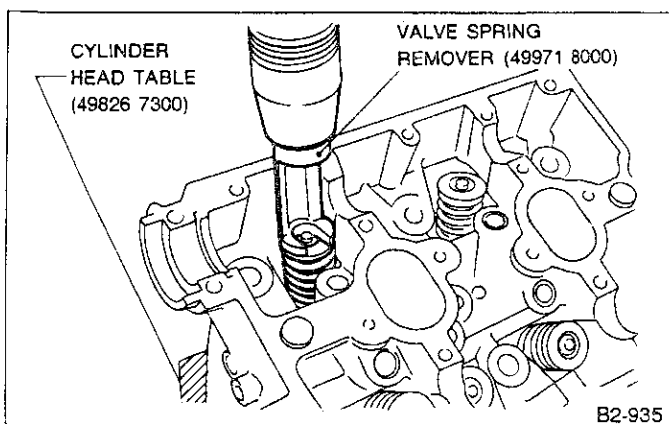
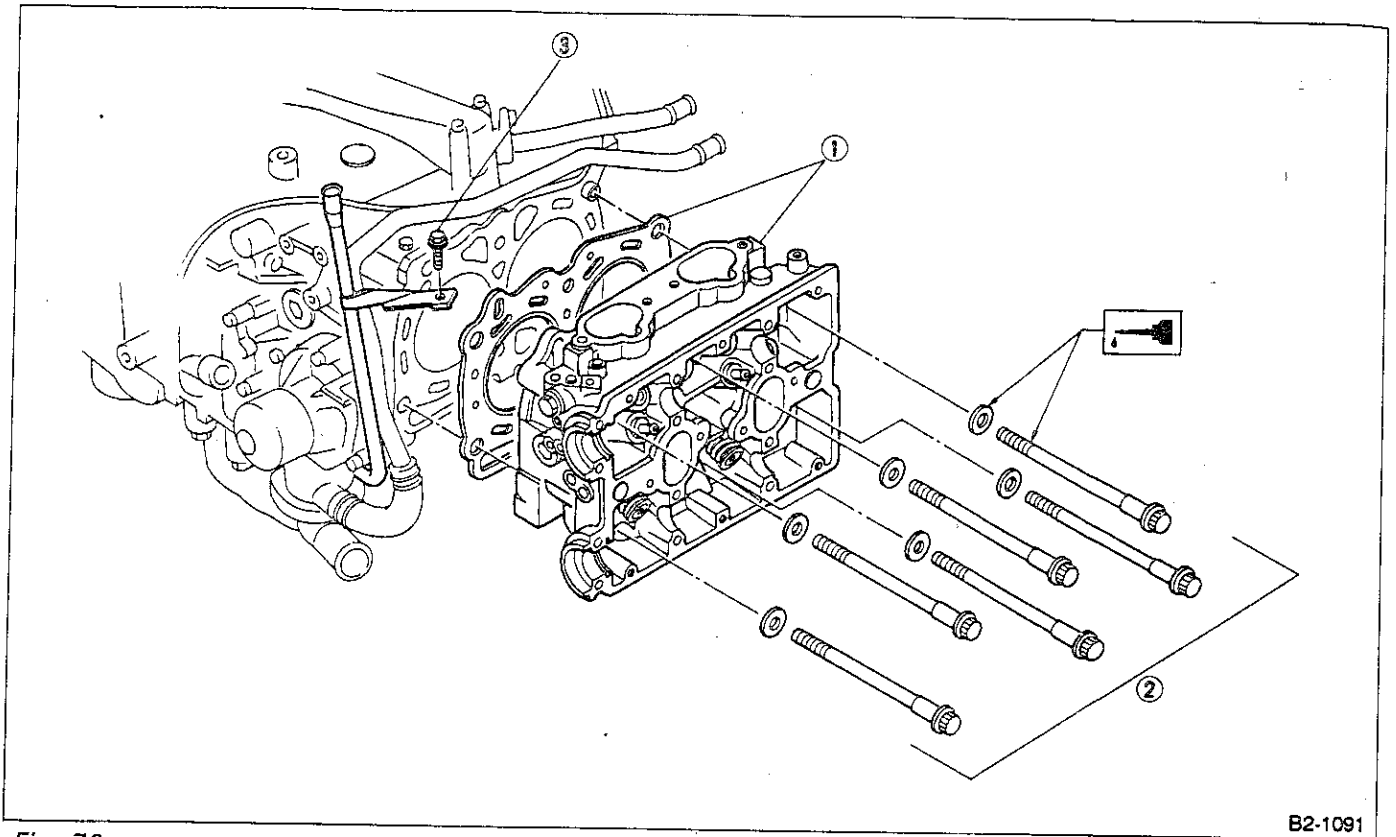


Fig. 75

E: INSTALLATION**1. CYLINDER HEAD**

B2-1091

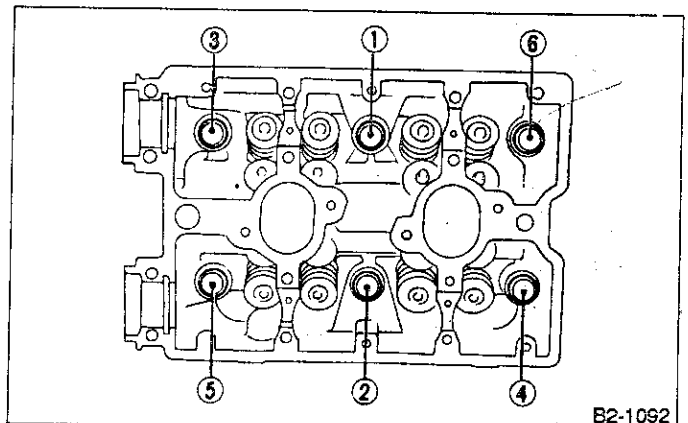
Fig. 76

1) Install cylinder head and gaskets on cylinder block.
Use new cylinder head gaskets.

2) Tighten cylinder head bolts.

- ✓ (1) Apply a coat of engine oil to washers and bolt threads.
 - ✓ (2) First tighten bolts to 29 N·m (3.0 kg-m, 22 ft-lb) in the order shown in the Figure. After this, tighten them further to 69 N·m (7.0 kg-m, 51 ft-lb) in the same order.
 - ✓ (3) Back off all bolts by 180°. After this, back them off another 180°.
 - ✓ (4) Tighten bolts ① and ② to 36.8 N·m (3.75 kg-m, 27.1 ft-lb).
 - ✓ (5) Tighten bolts ③, ④, ⑤ and ⑥ to 20 N·m (2.0 kg-m, 14 ft-lb).
 - (6) Tighten all bolts by 80 to 90° in numerical sequence.
- Do not tighten bolts more than 90°.**
- (7) Further tighten all bolts by 80 to 90° in numerical sequence.

Ensure that the total "re-tightening angle" (steps (6) and (7) at the left) do not exceed 180°.



B2-1092

Fig. 77

3) Install oil level gauge guide attaching bolt (left hand only).

2. INTAKE MANIFOLD

1) Install camshafts, rocker cover and related parts.

(Refer to 3. Camshaft [W3C0].)

2) Install camshaft sprockets, timing belt and related parts.

(Refer to 2. Timing Belt [W2C0].)

3) Install water pipe.

Use new gaskets.

4) Install intake manifold.

Use new gaskets.

5) Install coolant filler tank.

6) Install crank angle sensor, cam angle sensor and knock sensor. Use dry compressed air to remove foreign particles before installing sensors.

7) Connect each connector and/or install connector bracket.

8) Connect hoses and tubes to cylinder block.

9) Install brackets, alternator and air conditioner compressor.

10) Install power steering pump.

11) Install V-belt.

5. Cylinder Block

A: REMOVAL

1. RELATED PARTS

1) Remove timing belt, camshaft sprocket and related parts.

<Ref. to 2. Timing Belt [W2A0].>

2) Remove rocker cover, camshafts and related parts.

<Ref. to 3. Camshaft [W3A0].>

3) Remove cylinder head.

<Ref. to 4. Cylinder Head [W4A0].>

2. OIL PUMP AND WATER PUMP

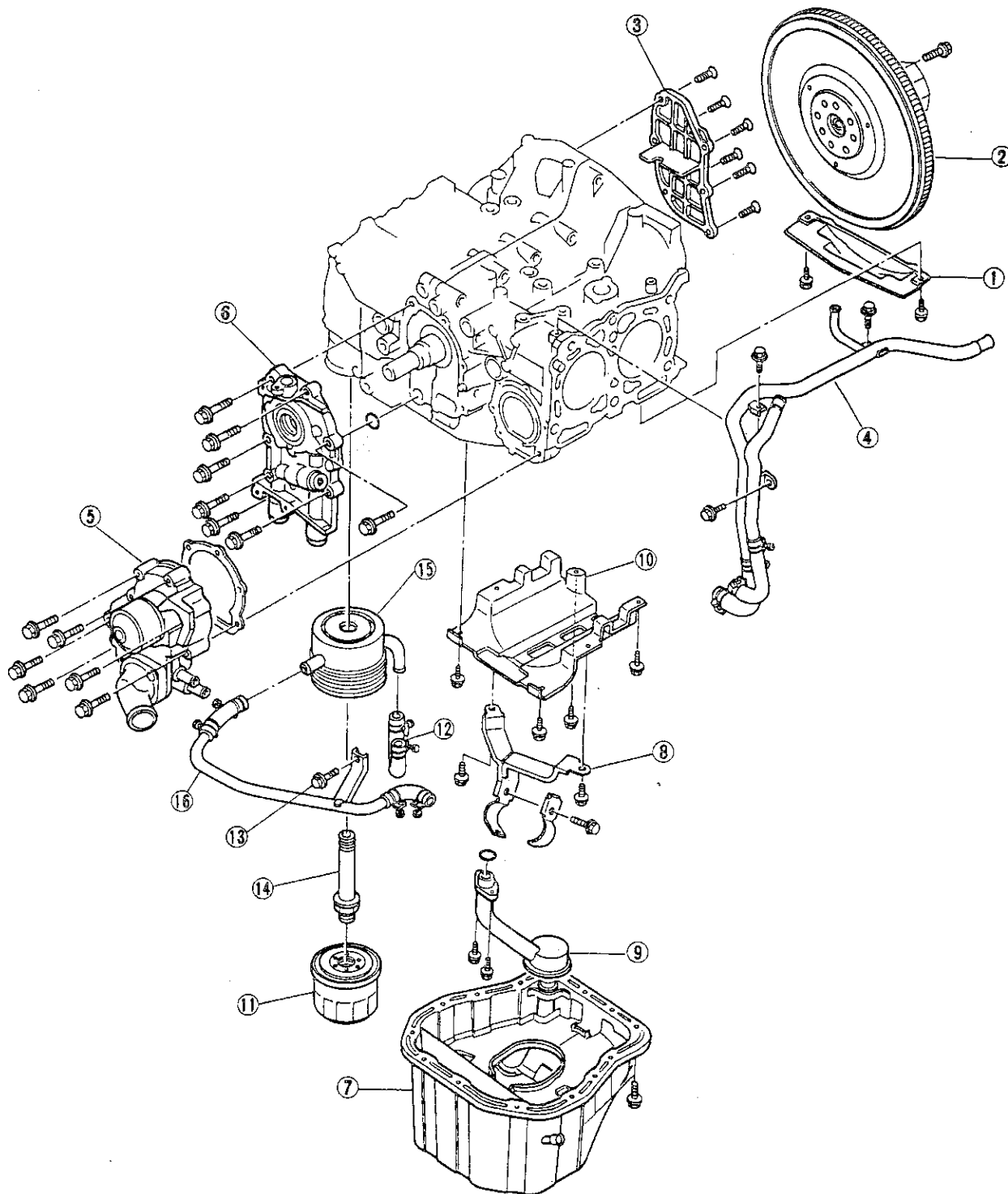


Fig. 78

B2-942

- 1) Remove housing cover.
 - 2) Remove flywheel.
- To lock crankshaft, use CRANKSHAFT STOPPER.

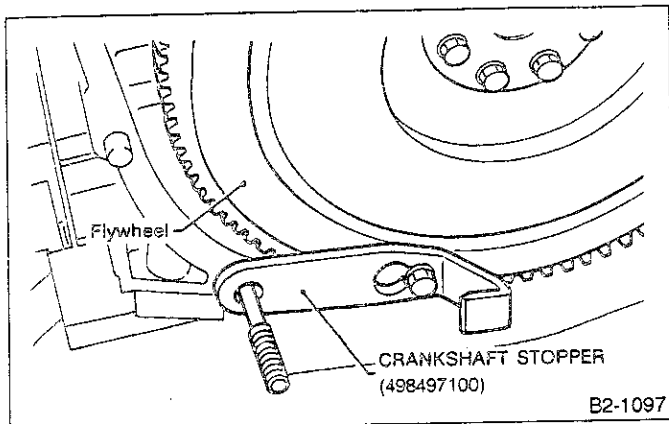


Fig. 79

- 3) Remove oil separator cover.
 - 4) Remove water pipe.
 - 5) Remove water pump.
 - 6) Remove oil pump from cylinder block.
- Use a standard screwdriver as shown in Figure when removing oil pump.

Be careful not to scratch the mating surface of cylinder block and oil pump.

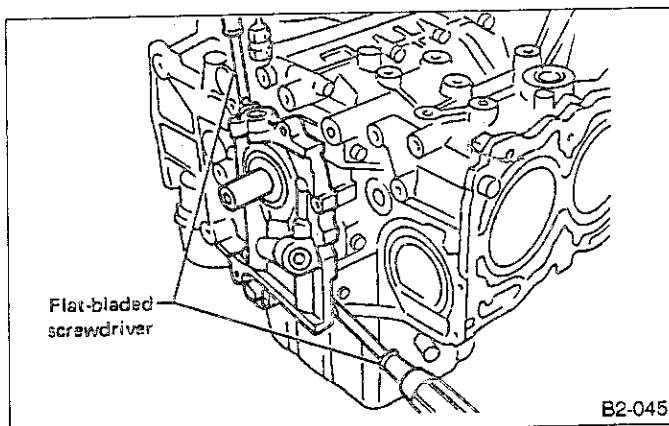


Fig. 80

7) Removal of oil pan.

- (1) Turn cylinder block with #2 and #4 piston sides facing upward.
- (2) Remove bolts which secure oil pan to cylinder block.
- (3) Insert a oil-pan cutter blade between cylinder block-to-oil pan clearance and remove oil pan.

Do not use a screwdriver or similar tool in place of oil-pan cutter blade.

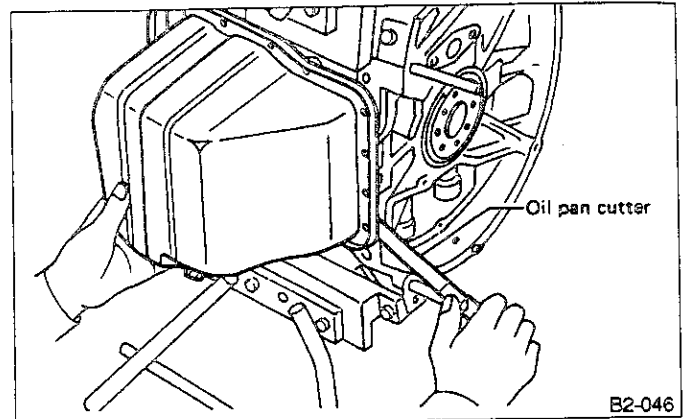
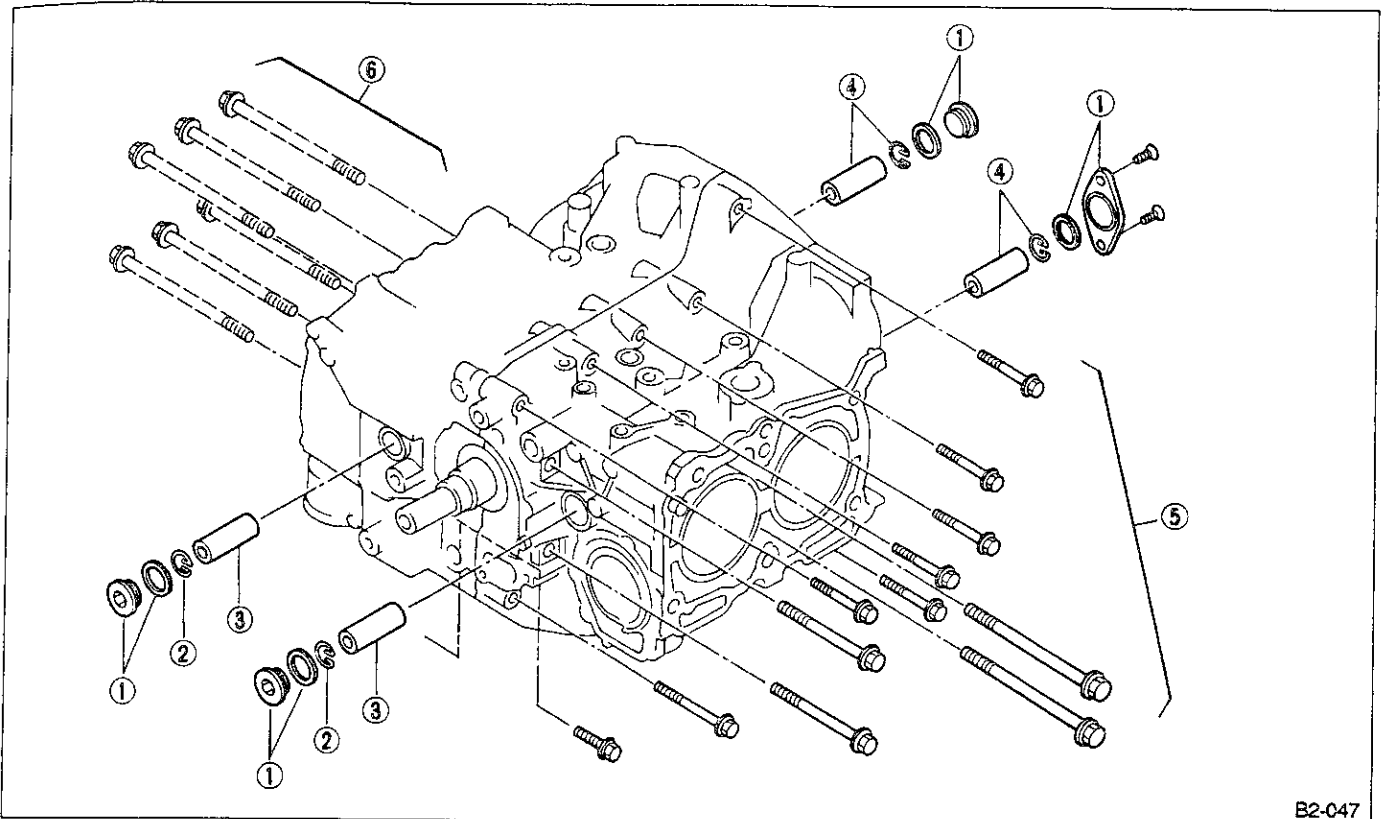


Fig. 81

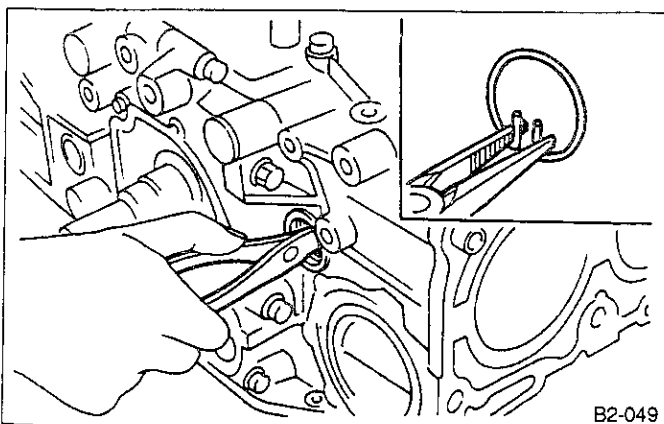
- 8) Remove oil strainer stay.
- 9) Remove oil strainer.
- 10) Remove baffle plate.
- 11) Remove oil filter.
- 12) Disconnect U-shaped hose from cylinder block.
- 13) Remove bolt which secure water pipe to cylinder block.
- 14) Remove connector pipe.
- 15) Remove oil cooler.
- 16) Remove water pipe from oil cooler.

B: DISASSEMBLY**1. PISTON PIN AND CYLINDER BLOCK CONNECTING BOLT**

B2-047

Fig. 82

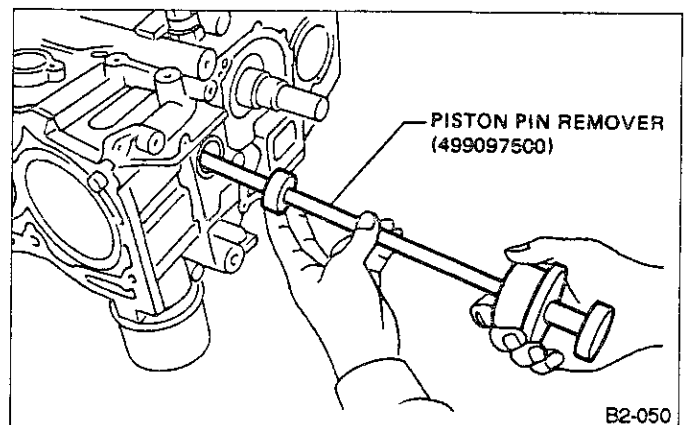
- 1) Remove service hole cover and service hole plugs using hexagon wrench (14 mm).
- 2) Rotate crankshaft to bring #1 and #2 pistons to BDC position, then remove piston circlip through service hole of #1 and #2 cylinders.



B2-049

Fig. 83

- 3) Draw out piston pin from #1 and #2 pistons.
Be careful not to confuse original combination of piston, piston pin and cylinder.

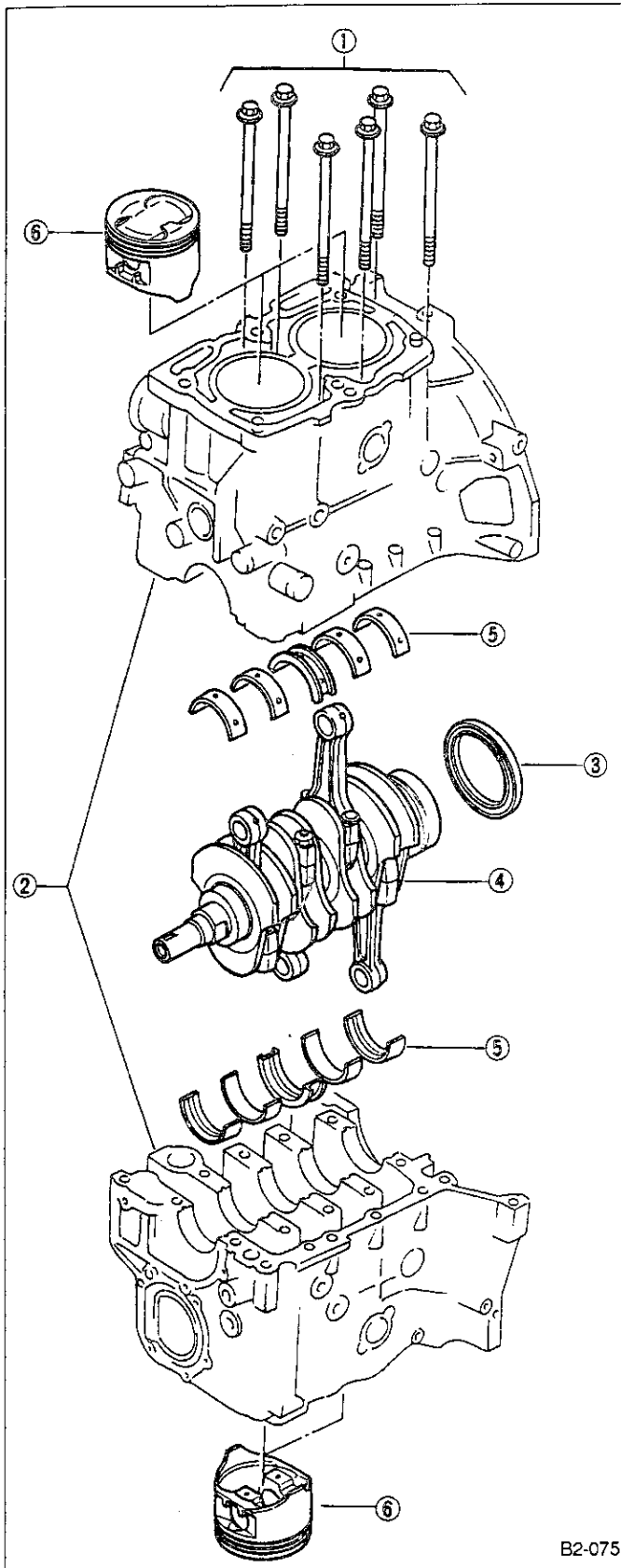


B2-050

Fig. 84

- 4) Similarly remove piston pins from #3 and #4 pistons.
- 5) Remove bolts which connect cylinder block on the side of #2 and #4 cylinders.
- 6) Back off bolts which connect cylinder block on the side of #1 and #3 cylinders two or three turns.

2. CYLINDER BLOCK



B2-075

Fig. 85

1) Set up cylinder block so that #1 and #3 cylinders are on the upper side, then remove cylinder block connecting bolts.

2) Separate left-hand and right-hand cylinder blocks.

When separating cylinder block, do not allow the connecting rod to fall and damage the cylinder block.

3) Remove rear oil seal.

4) Remove crankshaft together with connecting rod.

5) Remove crankshaft bearings from cylinder block by hand.

Do not confuse combination of crankshaft bearings. Press bearing at the end opposite to locking lip.

6) Draw out each piston from cylinder block using wooden bar or hammer handle.

Do not confuse combination of piston and cylinder.

3. CRANKSHAFT AND PISTON

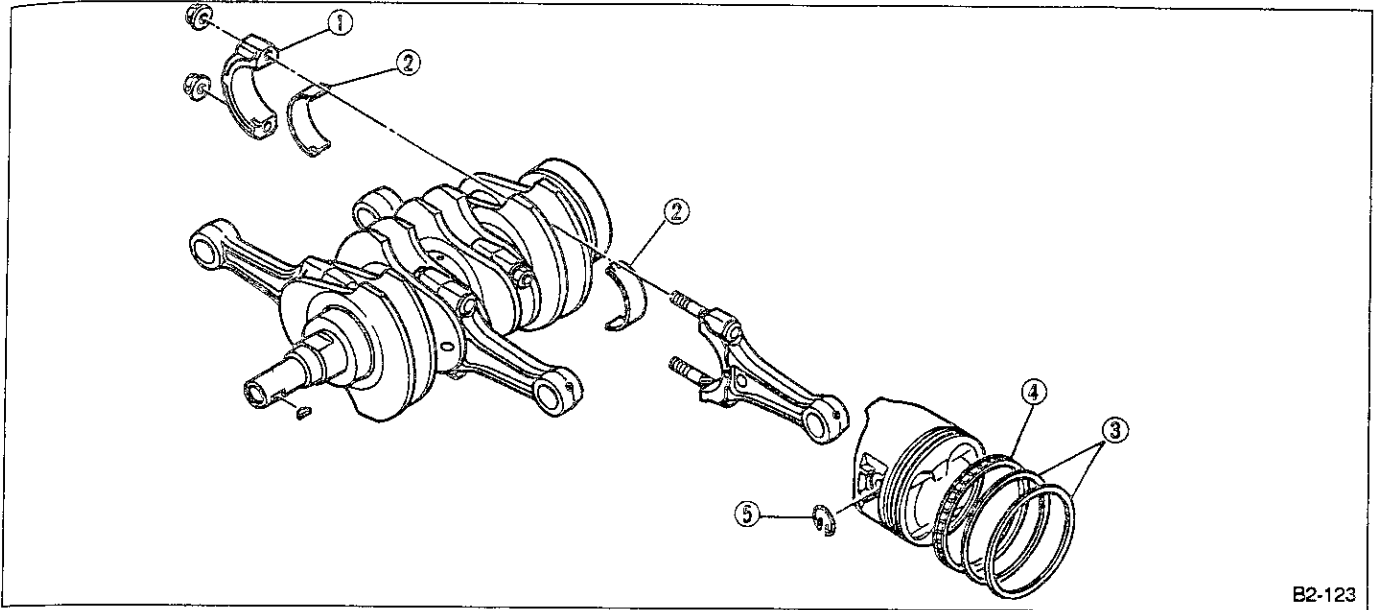


Fig. 86

- 1) Remove connecting rod cap.
- 2) Remove connecting rod bearing.

Arrange removed connecting rod, connecting rod cap and bearing in order to prevent confusion.

- 3) Remove the piston rings using the piston ring expander.
 - 4) Remove the oil ring by hand.
- Arrange the removed piston rings in good order to prevent confusion.
- 5) Remove circlip.

C: INSPECTION

1. CYLINDER BLOCK

- 1) Check for cracks and damage visually. Especially, inspect important parts by means of red check.
- 2) Check the oil passages for clogging.
- 3) Inspect crankcase surface that mates with cylinder head for warping by using a straight edge, and correct by grinding if necessary.

Warping limit:
0.05 mm (0.0020 in)

Grinding limit:
0.1 mm (0.004 in)

2. CYLINDER AND PISTON

- 1) The cylinder bore size is stamped on the cylinder block's front upper surface.

- (1) Standard sized pistons are classified into three grades, "A", "B" and "C". These grades should be used as a guideline in selecting a standard piston.
- (2) When piston is to be replaced due to general or cylinder wear, determine a suitable sized piston by measuring the piston clearance.

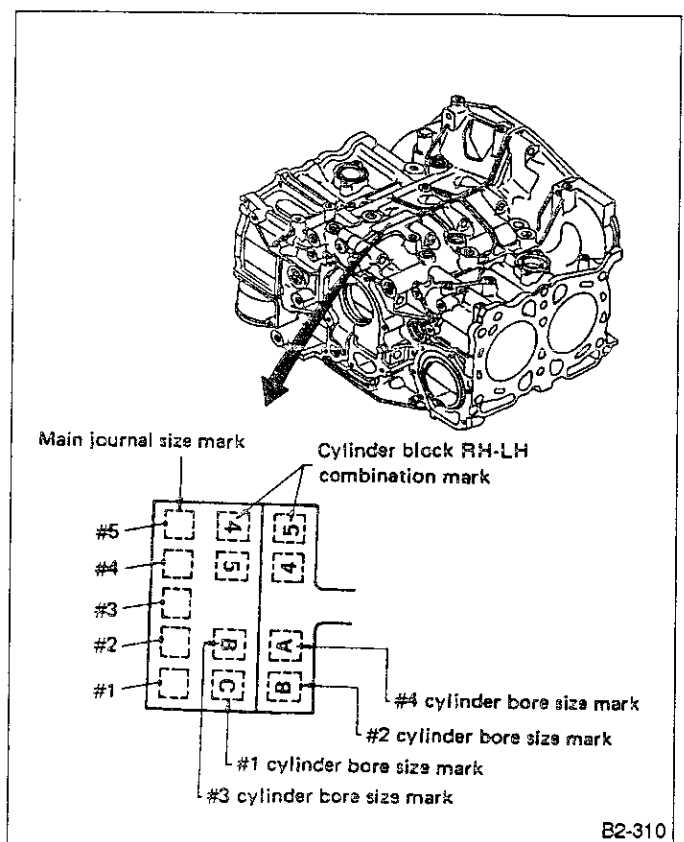


Fig. 87

(3) Proper combination of pistons and cylinders

	Cylinder		Piston		Piston clearance 20°C (68°F)
	Bore size symbol	Cylinder bore dia.	Piston grade symbol	Standard piston dia.	
2000cc	A	92.005 — 92.015 mm (3.6222 — 3.6226 in)	A	91.985 — 91.995 mm (3.6214 — 3.6218 in)	0.010 — 0.030 mm (0.0004 — 0.0012 in)
	B	91.995 — 92.005 mm (3.6218 — 3.6222 in)	B	91.975 — 91.985 mm (3.6211 — 3.6214 in)	
	C	91.985 — 91.995 mm (3.6214 — 3.6218 in)	C	91.965 — 91.975 mm (3.6207 — 3.6211 in)	

2) Measure the inner diameter of each cylinder in both the thrust and piston pin directions at the heights shown in the figure, using a cylinder bore gauge.

Measurement should be performed at a temperature 20°C (68°F).

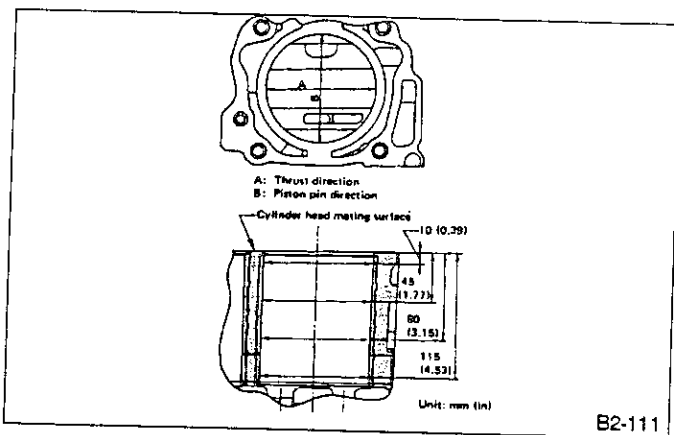


Fig. 88

Taper:**Standard**

0.015 mm (0.0006 in)

Limit

0.050 mm (0.0020 in)

Out-of-roundness:**Standard**

0.010 mm (0.0004 in)

Limit

0.050 mm (0.0020 in)

Cylinder to piston clearance at 20°C (68°F):**Standard**

0.010 — 0.030 mm (0.0004 — 0.0012 in)

Limit

0.060 mm (0.0024 in)

Standard diameter:**2000 cc****A** 92.005 — 92.015 mm

(3.6222 — 3.6226 in)

B 91.995 — 92.005 mm

(3.6218 — 3.6222 in)

C 91.985 — 91.995 mm

(3.6214 — 3.6218 in)

3) Boring and honing

(1) If the value of taper, out-of-roundness, or cylinder-to-piston clearance measured exceeds the specified limit or if there is any damage on the cylinder wall, rebore it to use an oversize piston.

When any of the cylinders needs reboring, all other cylinders must be bored at the same time, and use oversize pistons. Do not perform boring on one cylinder only, nor use an oversize piston for one cylinder only.

(2) Get four of the oversize pistons and measure the outer diameter of each piston at the height shown in the figure. (Thrust direction)

Measurement should be performed at a temperature of 20°C (68°F).

Piston outer diameter:**2000 cc****Standard****A** 91.985 — 91.995 mm (3.6214 — 3.6218 in)**B** 91.975 — 91.985 mm (3.6211 — 3.6214 in)**C** 91.965 — 91.975 mm (3.6207 — 3.6211 in)

0.25 mm (0.0098 in) oversize

92.225 — 92.235 mm (3.6309 — 3.6313 in)

0.50 mm (0.0197 in) oversize

92.475 — 92.485 mm (3.6407 — 3.6411 in)

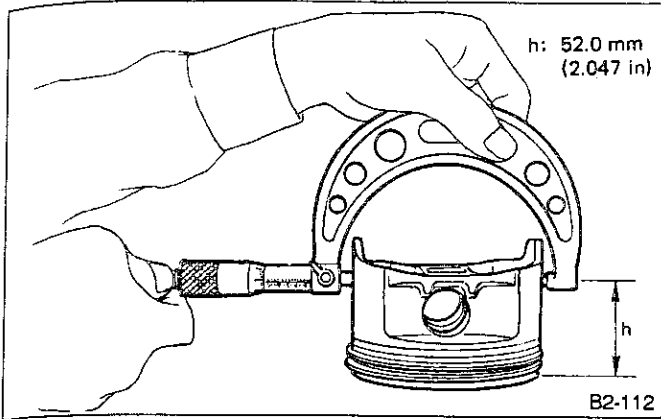


Fig. 89

(3) If the cylinder inner diameter exceeds the limit after boring and honing, replace the crankcase.

Immediately after reboring, the cylinder diameter may differ from its real diameter due to temperature rise. Thus, pay attention to this when measuring the cylinder diameter.

Limit of cylinder enlarging (boring):
0.5 mm (0.020 in)

3. PISTON AND PISTON PIN

- 1) Check pistons and piston pins for damage, cracks, and wear and the piston ring grooves for wear and damage. Replace if defective.
- 2) Measure the piston-to-cylinder clearance at each cylinder as instructed in CYLINDER AND PISTON. If any of the clearances is not to specification, replace the piston or bore the cylinder to use an oversize piston.
- 3) Make sure that piston pin can be inserted into the piston pin hole with a thumb at 20°C (68°F). Replace if defective.

Standard clearance between piston pin and hole in piston:

0.001 — 0.013 mm (0.00004 — 0.00051 in)

Standard clearance between piston pin and hole in connecting rod:

0 — 0.022 mm (0 — 0.0009 in)

4. PISTON RING

1) If piston ring is broken, damaged, or worn, or if its tension is insufficient, or when the piston is replaced, replace piston ring with a new one of the same size as the piston.

"R" or "N" is marked on the end of the top and second rings. When installing the rings to the piston, face this mark upward.

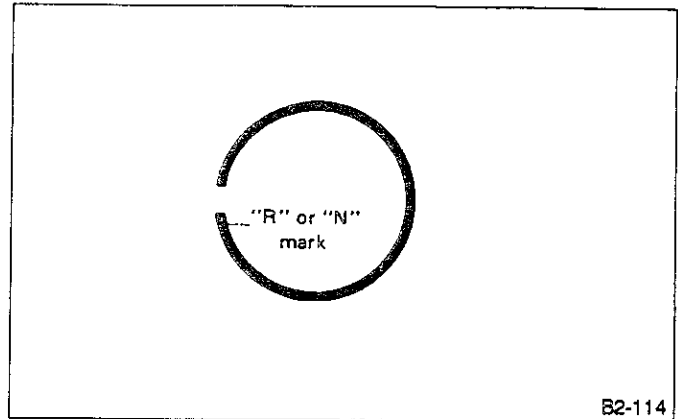


Fig. 90

The oil ring is a combined ring consisting of two rails and a spacer in between. When installing, be careful not to make misassembly.

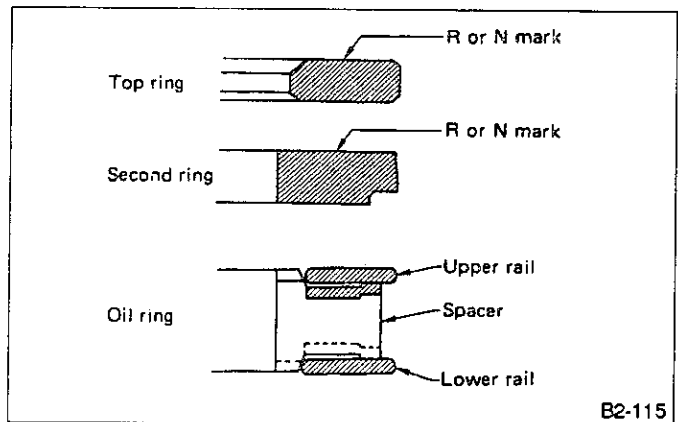


Fig. 91

2) Squarely place piston ring and oil ring in cylinder, and measure the piston ring gap with a thickness gauge.

Unit: mm (in)

		Standard	Limit
Piston ring gap	Top ring	0.20 — 0.35 (0.0079 — 0.0138)	1.0 (0.039)
	Second ring	0.20 — 0.35 (0.0079 — 0.0138)	1.0 (0.039)
	Oil ring rail	0.20 — 0.70 (0.0079 — 0.0276)	1.5 (0.059)

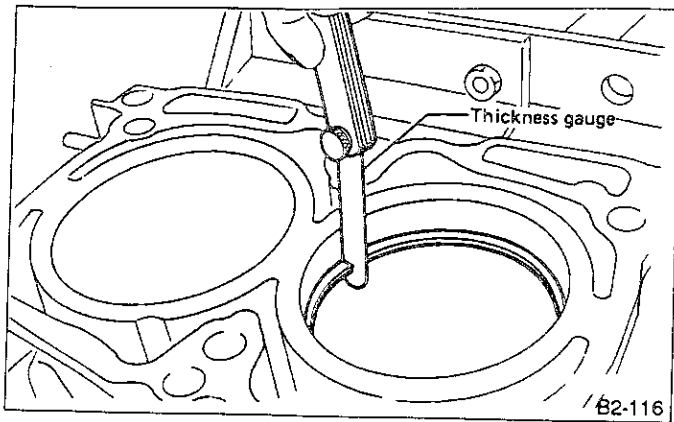


Fig. 92

3) Measure the clearance between piston ring and piston ring groove with a thickness gauge.

Before measuring the clearance, clean the piston ring groove and piston ring.

Unit:mm (in)

		Standard	Limit
Clearance between piston ring and piston ring groove	Top ring	0.04 — 0.08 (0.0016 — 0.0031)	0.15 (0.0059)
	Second ring	0.03 — 0.07 (0.0012 — 0.0028)	0.15 (0.0059)

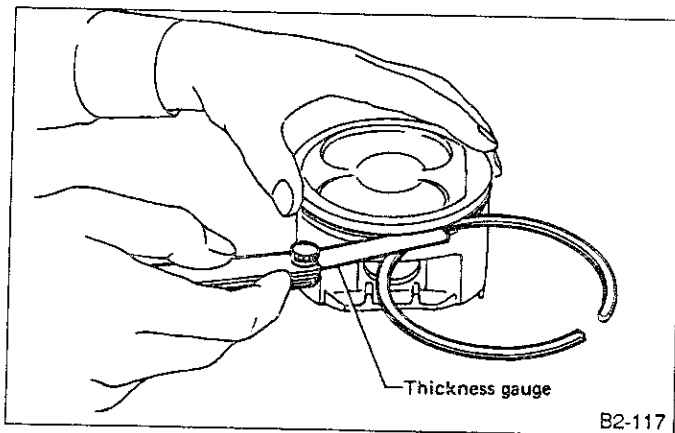


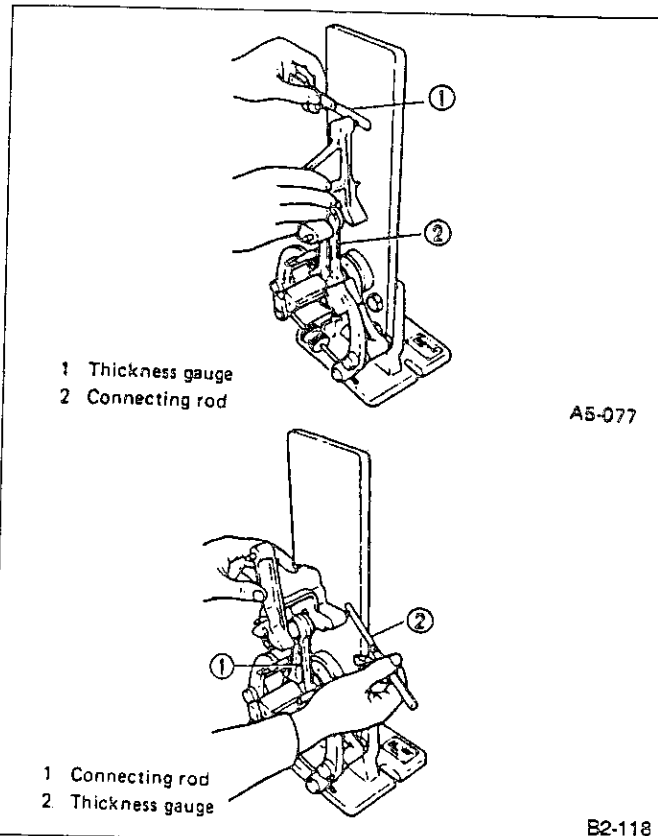
Fig. 93

5. CONNECTING ROD

1) Replace connecting rod, if the large or small end thrust surface is damaged.

2) Check for bend or twist using a connecting rod aligner. Replace connecting rod if the bend or twist exceeds the limit.

Limit of bend or twist per 100 mm (3.94 in) in length:
0.10 mm (0.0039 in)



A5-077

B2-118

Fig. 94

3) Install connecting rod fitted with bearing to crankshaft and measure the side clearance (thrust clearance). Replace connecting rod if the side clearance exceeds the specified limit.

Connecting rod side clearance:

Standard

0.070 — 0.330 mm (0.0028 — 0.0130 in)

Limit

0.4 mm (0.016 in)

Unit: mm (in)

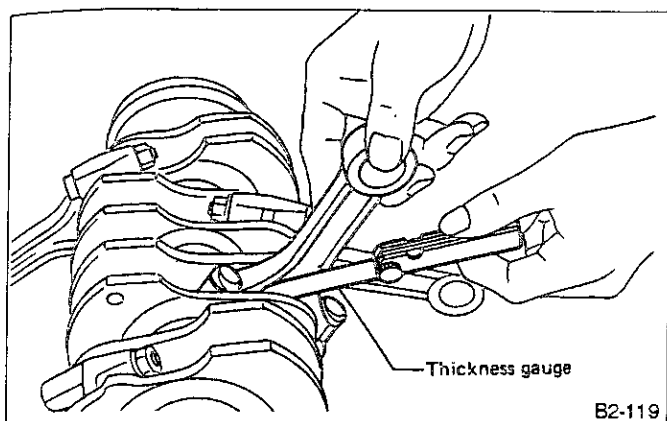


Fig. 95

4) Inspect connecting rod bearing for scar, peeling, seizure, melting, wear, etc.

5) Measure the oil clearance on individual connecting rod bearings by means of plastigauge. If any oil clearance is not within specification, replace the defective bearing with a new one of standard size or undersize as necessary, necessary. (See the table below.)

Connecting rod oil clearance:
Standard

0.025 — 0.055 mm (0.0010 — 0.0022 in)

Limit

0.06 mm (0.0024 in)

Bearing	Bearing size (Thickness at center)	Outer diameter of crank pin
Standard	1.487 — 1.496 (0.0585 — 0.0589)	51.984 — 52.000 (2.0466 — 2.0472)
0.03 undersize	1.505 — 1.508 (0.0593 — 0.0594)	51.954 — 51.970 (2.0454 — 2.0461)
0.05 undersize	1.515 — 1.518 (0.0596 — 0.0598)	51.934 — 51.950 (2.0446 — 2.0453)
0.25 undersize	1.615 — 1.618 (0.0636 — 0.0637)	51.734 — 51.750 (2.0368 — 2.0374)

6) Inspect bushing at connecting rod small end, and replace if worn or damaged. Also measure the piston pin clearance at the connecting rod small end.

Clearance between piston pin and bushing:
Standard

0 — 0.022 mm (0 — 0.0009 in)

Limit

0.030 mm (0.0012 in)

 Replacement procedure is as follows.

(1) Remove bushing from connecting rod with REMOVER & REPLACER and press.

(2) Press bushing with REMOVER & REPLACER after applying oil on the periphery of bushing.

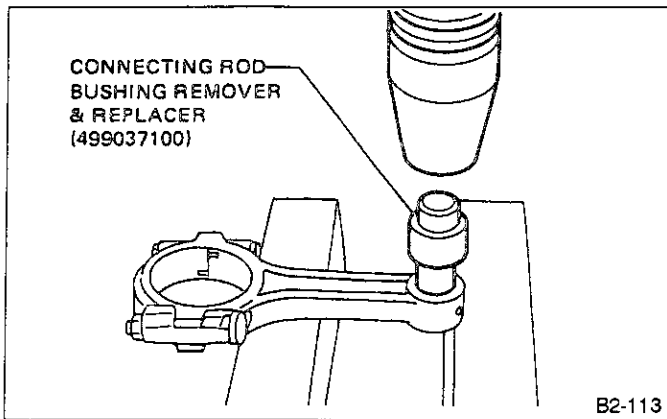


Fig. 96

- (3) Make two 3 mm (0.12 in) holes in bushing. Ream the inside of bushing.
- (4) After completion of reaming, clean bushing to remove chips.

6. CRANKSHAFT AND CRANKSHAFT BEARING

- 1) Clean crankshaft completely and check for cracks by means of red check etc., and replace if defective.
- 2) Measure the crankshaft bend, and correct or replace if it exceeds the limit.

If a suitable V-block is not available, install #1 and #5 crankshaft bearing on cylinder block, position crankshaft on these bearings and measure crankshaft bend using a dial gauge.

Crankshaft bend limit:
0.035 mm (0.0014 in)

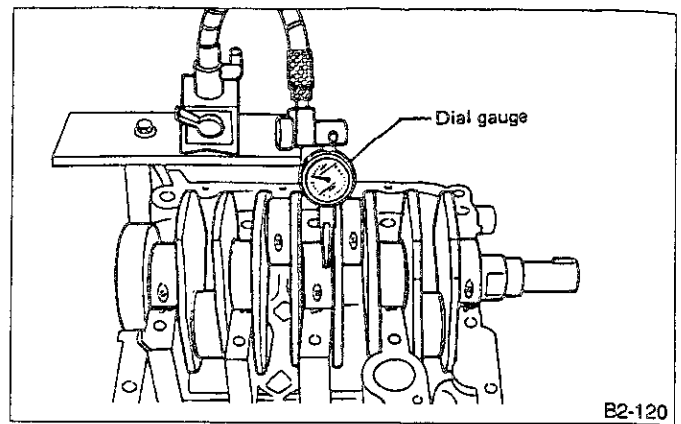


Fig. 97

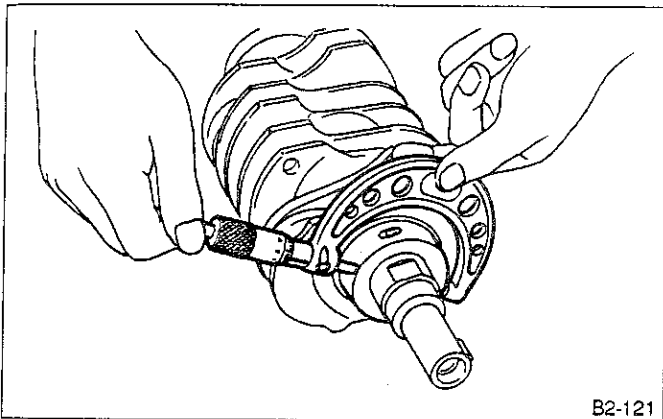
- 3) Inspect the crank journal and crankpin for wear. If not to specifications, replace bearing with an undersize one, and replace or recondition crankshaft as necessary. When grinding crank journal or crankpin, finish them to the specified dimensions according to the undersize bearing to be used.

Crankpin and crank journal:

- Out-of-roundness**
0.03 mm (0.0012 in) or less
- Taper limit**
0.07 mm (0.0028 in)
- Grinding limit**
0.25 mm (0.0098 in)

Unit: mm (in)

		Crank journal			Crank pin O.D.
		#1, #5	#2, #4	#3	
Standard	Journal O.D.	59.984 — 60.000 (2.3616 — 2.3622)	59.984 — 60.000 (2.3616 — 2.3622)	59.984 — 60.000 (2.3616 — 2.3622)	51.984 — 52.000 (2.0466 — 2.0472)
	Bearing size (Thickness at center)	1.998 — 2.011 (0.0787 — 0.0792)	2.000 — 2.013 (0.0787 — 0.0793)	2.000 — 2.013 (0.0787 — 0.0793)	1.487 — 1.496 (0.0585 — 0.0589)
0.03 (0.0012) undersize	Journal O.D.	59.954 — 59.970 (2.3604 — 2.3610)	←	←	51.954 — 51.970 (2.0454 — 2.0461)
	Bearing size (Thickness at center)	2.017 — 2.020 (0.0794 — 0.0795)	2.019 — 2.022 (0.0795 — 0.0796)	2.019 — 2.022 (0.0795 — 0.0796)	1.505 — 1.508 (0.0593 — 0.0594)
0.05 (0.0020) undersize	Journal O.D.	59.934 — 59.950 (2.3596 — 2.3602)	←	←	51.934 — 51.950 (2.0446 — 2.0453)
	Bearing size (Thickness at center)	2.027 — 2.030 (0.0798 — 0.0799)	2.029 — 2.032 (0.0799 — 0.0800)	2.029 — 2.032 (0.0799 — 0.0800)	1.515 — 1.518 (0.0596 — 0.0598)
0.25 (0.0098) undersize	Journal O.D.	59.734 — 59.750 (2.3517 — 2.3524)	←	←	51.734 — 51.750 (2.0368 — 2.0374)
	Bearing size (Thickness at center)	2.127 — 2.130 (0.0837 — 0.0839)	2.129 — 2.132 (0.0838 — 0.0839)	2.129 — 2.132 (0.0838 — 0.0839)	1.615 — 1.618 (0.0636 — 0.0637)



B2-121

Fig. 98

4) Measure the thrust clearance of crankshaft at center bearing. If the clearance exceeds the limit, replace bearing.

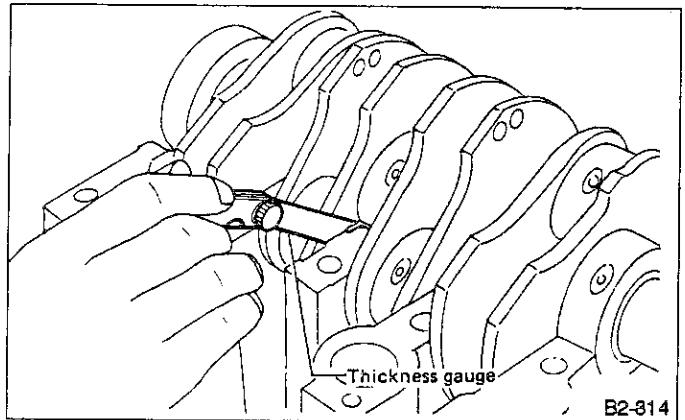
Crankshaft thrust clearance:

Standard

0.030 — 0.115 mm (0.0012 — 0.0045 in)

Limit

0.25 mm (0.0098 in)



B2-314

Fig. 99

5) Inspect individual crankshaft bearings for signs of flaking, seizure, melting, and wear.

6) Measure the oil clearance on each crankshaft bearing by means of piastigauge. If the measurement is not within the specification, replace defective bearing with an undersize one, and replace or recondition crankshaft as necessary.

Unit: mm (in)

Crankshaft oil clearance		
Standard	#1, #5	0.010 — 0.030 (0.0004 — 0.0012)
	#2, #3, #4	0.010 — 0.030 (0.0004 — 0.0012)
Limit	#1, #5	0.040 mm (0.0016 in)
	#2, #3, #4	0.035 mm (0.0074)

D: ASSEMBLY

1. CRANKSHAFT AND PISTON

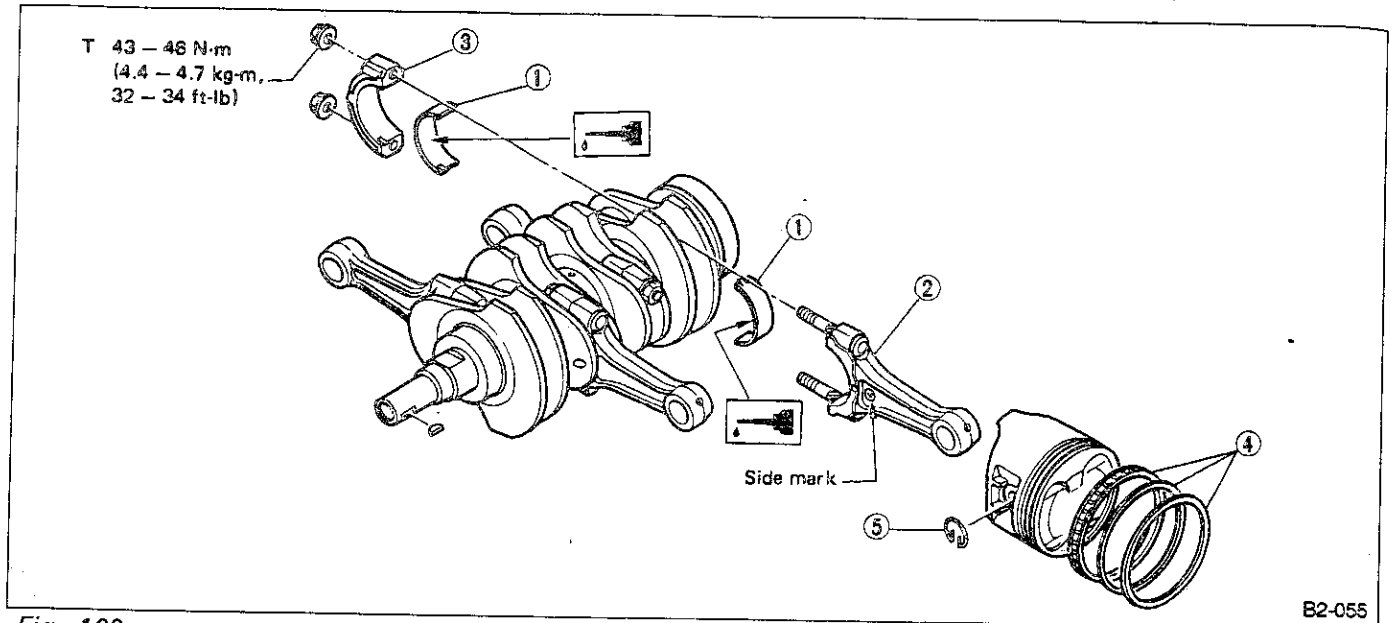


Fig. 100

B2-055

1) Install connecting rod bearings on connecting rods and connecting rod caps.

Apply oil to the surfaces of the connecting rod bearings.

2) Install connecting rod on crankshaft.

Position each connecting rod with the side marked facing forward.

3) Install connecting rod cap with connecting rod nut. Ensure the arrow on connecting rod cap faces the front during installation.

a. Each connecting rod has its own mating cap. Make sure that they are assembled correctly by checking their matching number.

b. When tightening the connecting rod nuts, apply oil on the threads.

4) Installation of piston rings and oil ring.

(1) Install oil ring spacer, upper rail and lower rail in this order by hand. Then install second ring and top ring with a piston ring expander.

(2) Position the gaps of the piston rings and oil ring as shown in the figure.

5) Install circlip.

Install circlips in piston holes located opposite service holes in cylinder block, when positioning all pistons in the corresponding cylinders.

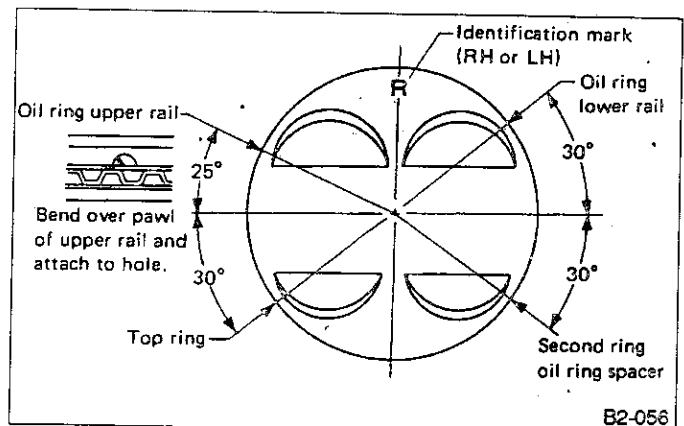


Fig. 101

B2-056

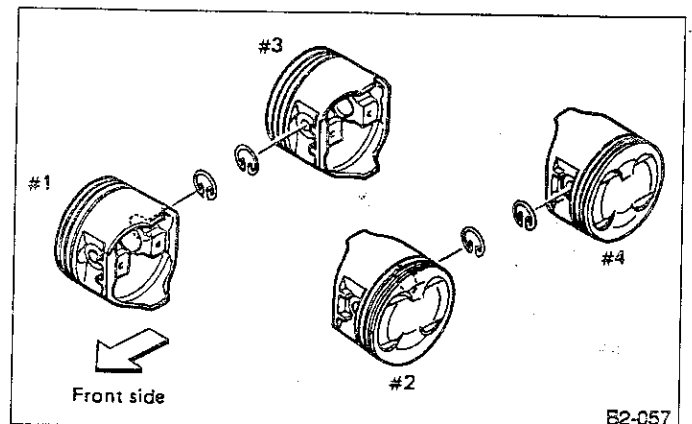


Fig. 102

B2-057

2. CYLINDER BLOCK

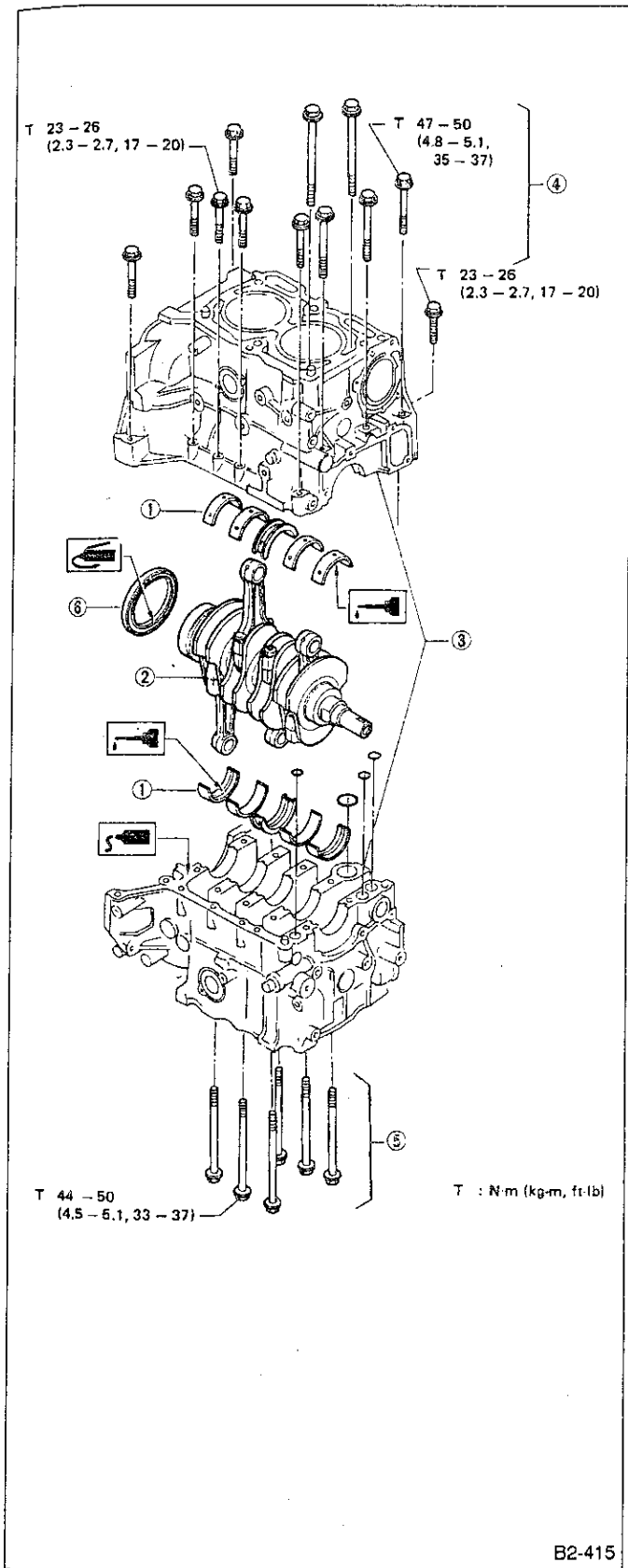


Fig. 103

1) Install ENGINE STAND to cylinder block, then install crankshaft bearings.

Remove oil the mating surface of bearing and cylinder block before installation. Also apply a coat of engine oil to crankshaft pins.

- 2) Position crankshaft on the #1 & #3 cylinder block.
- 3) Apply fluid packing to the mating surface of #1 & #3 cylinder block, and position the #2 & #4 cylinder block on #1 & #3 cylinder block.

Fluid packing:

Three-bond 1215 or equivalent

Do not allow fluid packing to jut into O-ring grooves, oil passages, bearing grooves, etc.

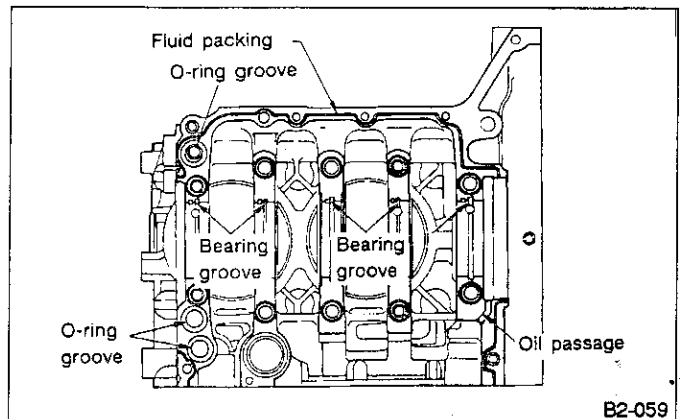


Fig. 104

4) Temporarily tighten #2 & #4 cylinder block side connecting bolts to 20 N·m (2 kg-m, 14 ft-lb).

5) Turn cylinder block so that it is horizontal. Tighten all cylinder block connecting bolts to specified torque, starting with bolts on the #1 & #3 cylinder block side.

6) Install rear oil seal.

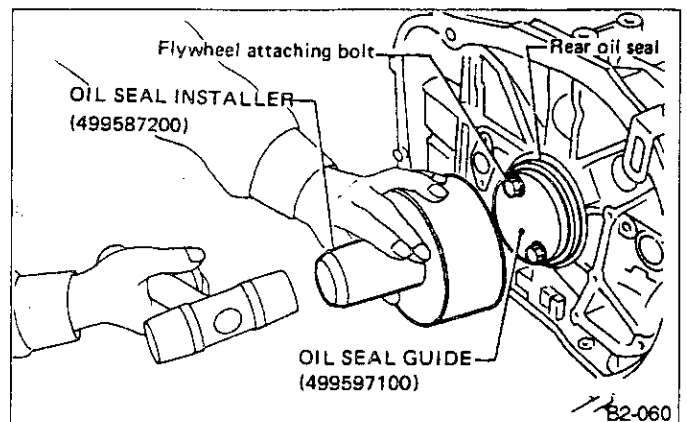


Fig. 105

3. PISTON AND PISTON PIN (#1 and #2)

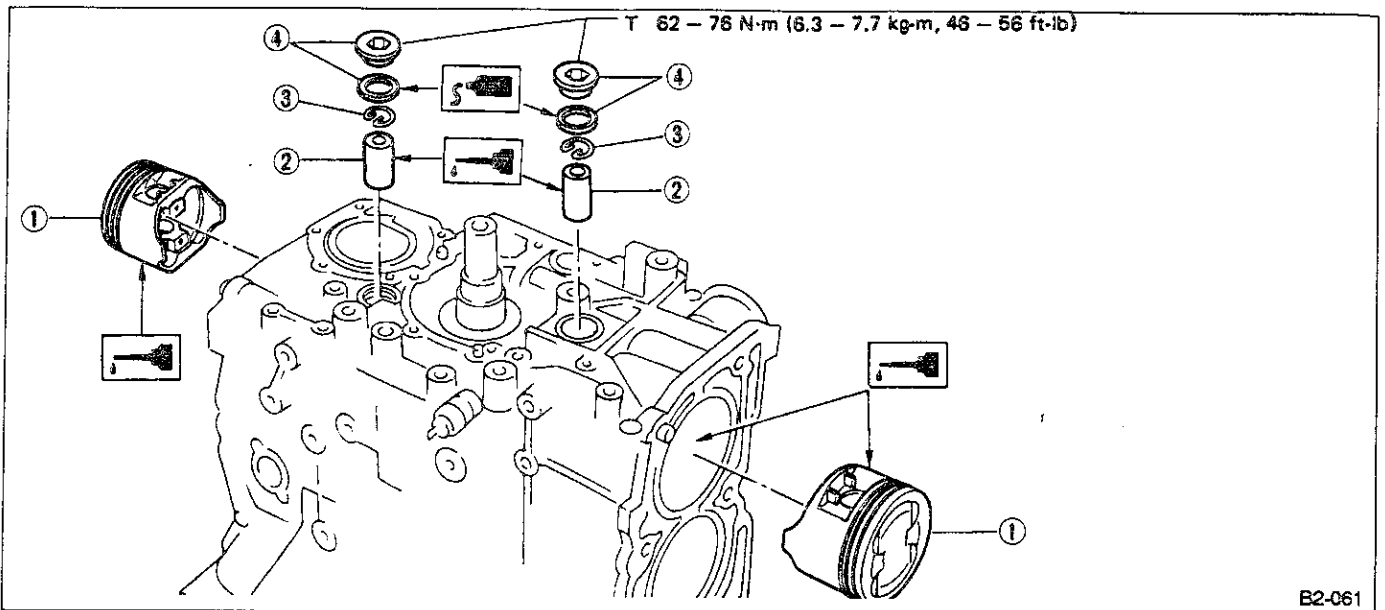


Fig. 106

1) Installing piston

- (1) Turn cylinder block so that #1 and #2 cylinders face upward.
- (2) Turn crankshaft so that #1 and #2 connecting rods are set at bottom dead center.
- (3) Apply a coat of engine oil to pistons and cylinders and insert pistons in their cylinders.

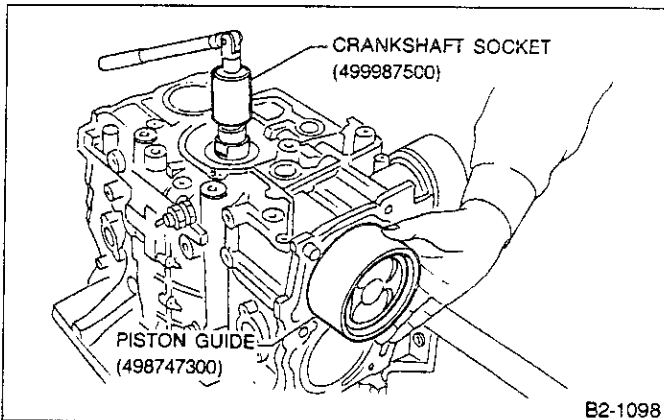


Fig. 107

2) Installing piston pin

- (1) Insert the PISTON PIN GUIDE into service hole to align piston pin hole with connecting rod small end. Apply a coat of engine oil to PISTON PIN GUIDE before insertion.

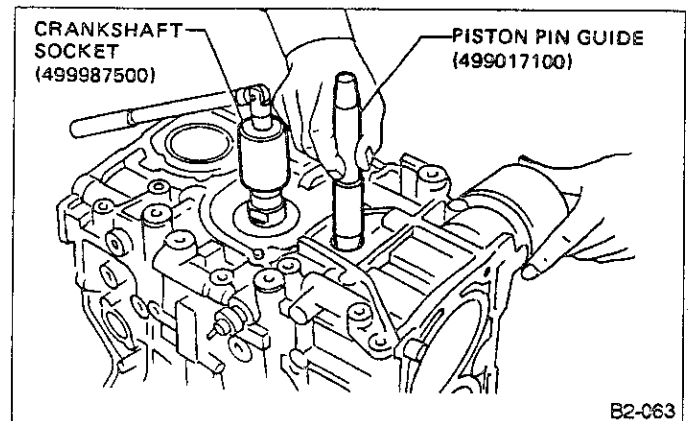


Fig. 108

- (2) Apply a coat of engine oil to piston pin and insert piston pin into piston and connecting rod through service hole.
- (3) Install circlip.

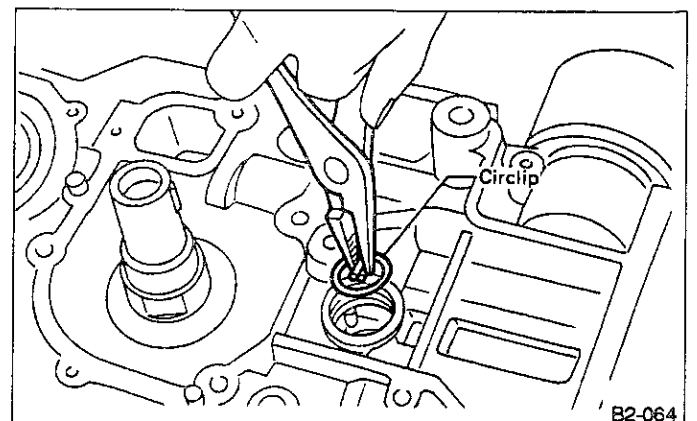


Fig. 109

(4) Install service hole plug and gasket.

Use a new gasket and apply a coat of fluid packing to it before installation.

Fluid packing:
Three-bond 1105

4. PISTON AND PISTON PIN (#3 and #4)

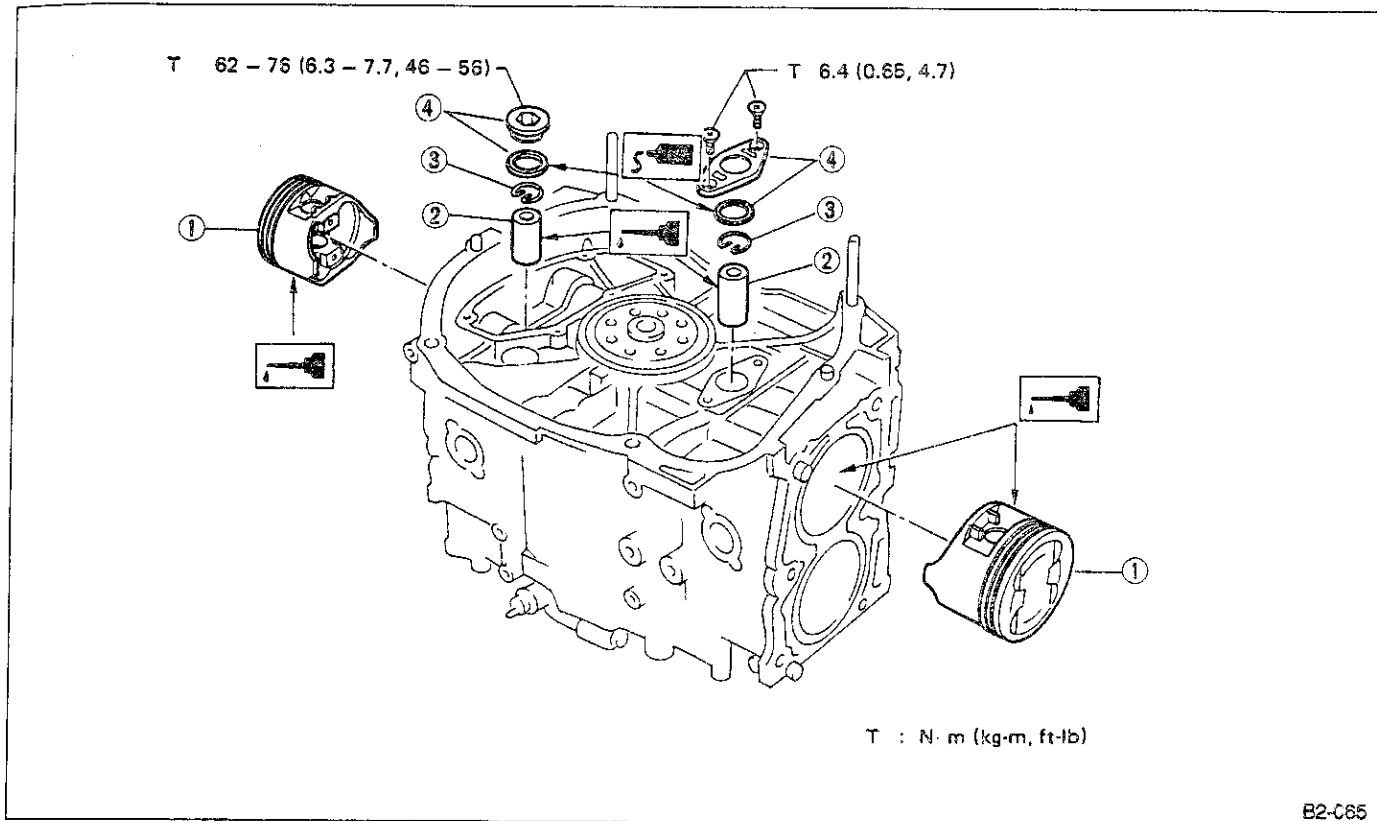


Fig. 110

Turn cylinder block so that #3 and #4 cylinders face upward. Using the same procedures as used for #1 and #2 cylinders, install pistons and piston pins.

E: INSTALLATION

1. OIL PUMP AND WATER PUMP

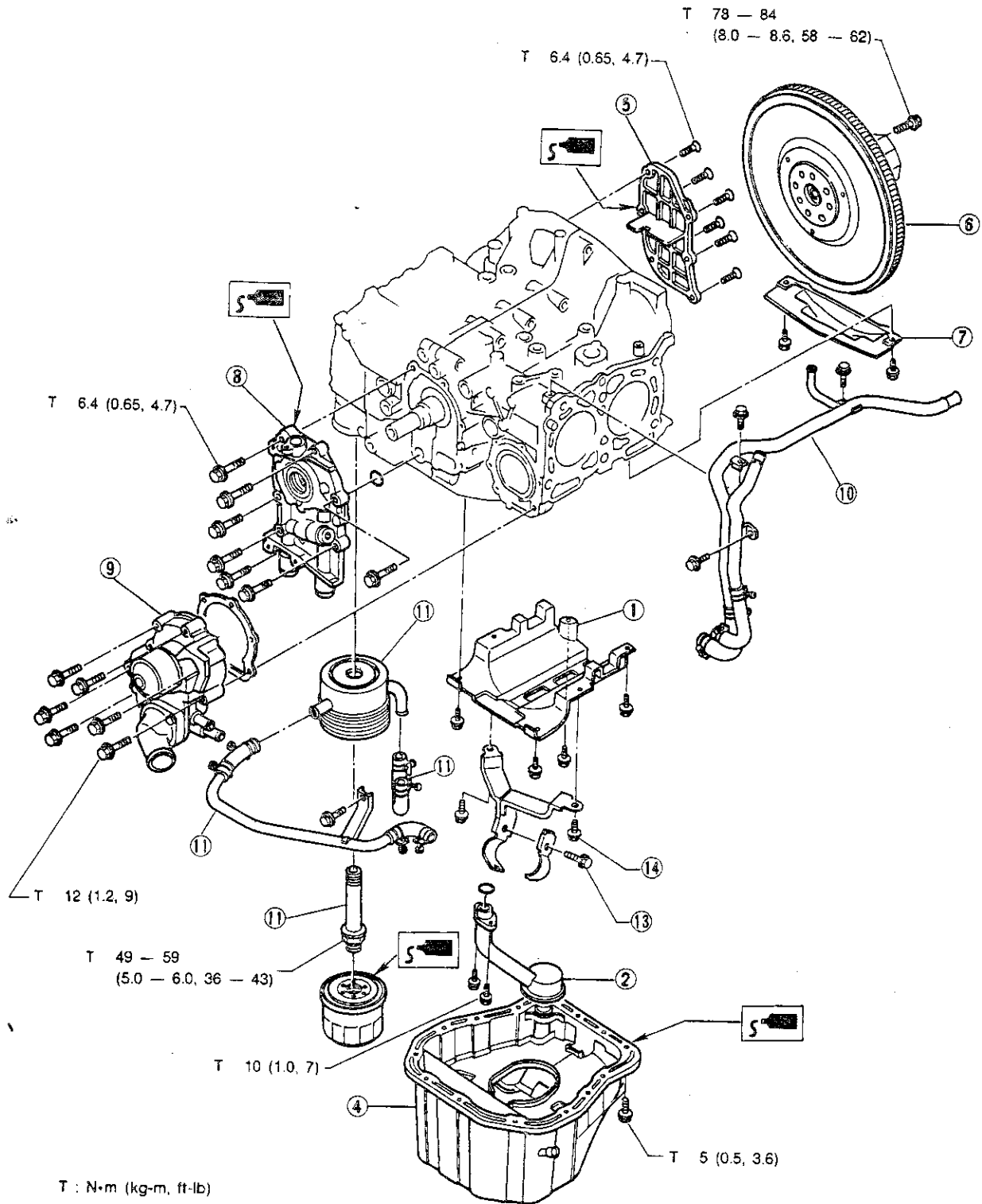
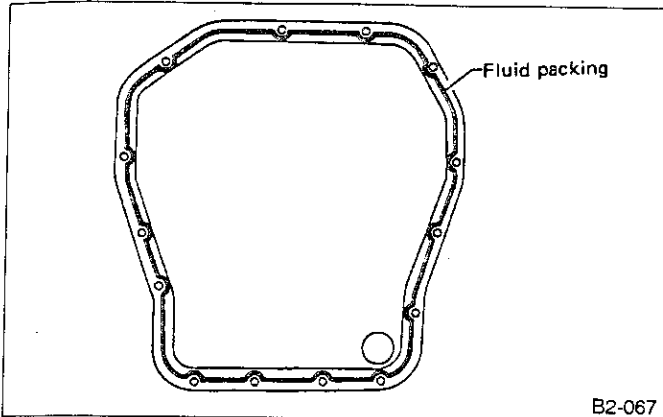


Fig. 111

B2-1096

- 1) Install baffle plate.
- 2) Install oil strainer and O-ring
- 3) Install oil strainer stay.
- 4) Apply fluid packing to matching surfaces and install oil pan.

Fluid packing:
Three-bond 1207C or equivalent

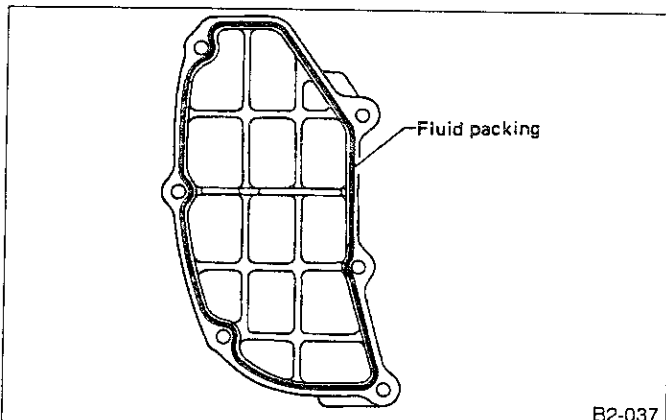


B2-067

Fig. 112

- 5) Apply fluid packing to matching surfaces and install oil separator cover.

Fluid packing:
Three-bond 1215 or equivalent

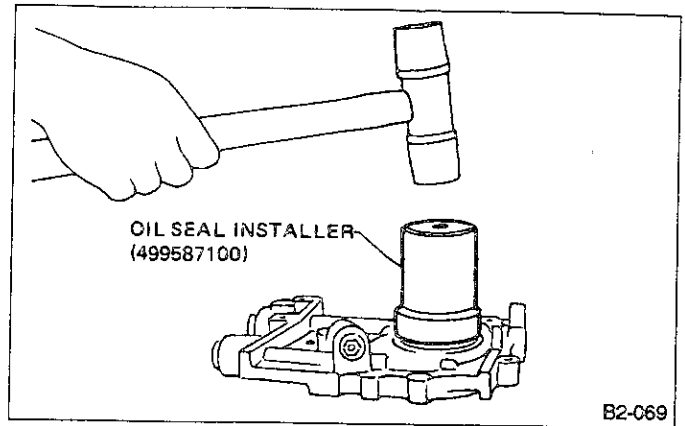


B2-037

Fig. 113

- 6) Install flywheel or drive plate.
- 7) Install housing cover.
- 8) Installation of oil pump.

(1) Discard front oil seal after removal. Replace with a new one.

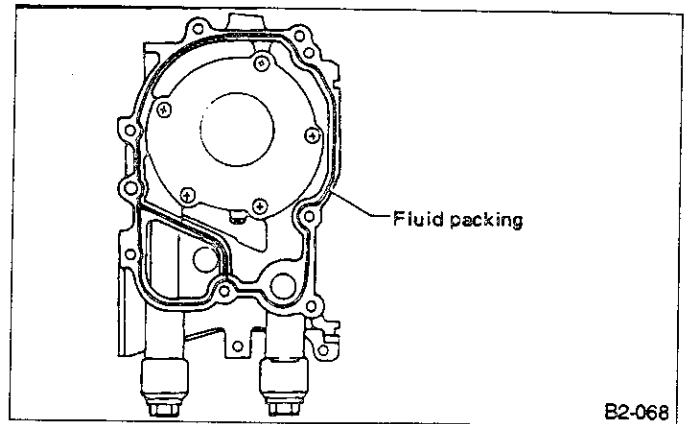


B2-069

Fig. 114

- (2) Apply fluid packing to matching surface of oil pump.

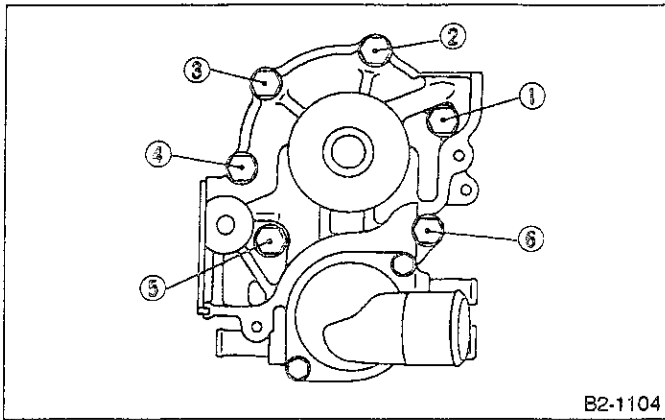
Fluid packing:
Three-bond 1215 or equivalent



B2-068

Fig. 115

- (3) Install oil pump on cylinder block. Be careful not to damage oil seal during installation.
 - a. Do not forget to install O-ring and seal when installing oil pump.
 - b. Align flat surface of oil pump's inner rotor with crankshaft before installation.
- 9) Install water pump and gasket.
 - a. Be sure to use a new gasket.
 - b. When installing water pump, tighten bolts in two stages in the numerical sequence shown in Figure.



B2-1104

Fig. 116

- 10) Install water pipes.
- 11) Install oil cooler, connector and water pipe.
- 12) Install oil filter.

2. RELATED PARTS

- 1) Install cylinder head and intake manifold.
(Ref. to 4. Cylinder Head [W4E0].)
- 2) Install camshaft and rocker cover.
(Ref. to 3. Camshaft [W300X].)
- 3) Install timing belt, camshaft sprocket and related parts.
(Ref. to 2. Timing Belt [W2C0].)

T TROUBLESHOOTING

1. Engine Trouble in General

Symbols shown in the chart refer to the possibility of reason for the trouble in order ("Very often" to "Rarely")													No.	TROUBLE	
⊙— Very often ○— Sometimes △— Rarely													1	Starter does not turn.	
													2	Engine will not start.	Initial combustion does not occur.
													3		Initial combustion occurs.
													4		Engine stalls after initial combustion.
													5		Rough idle and engine stall.
													6	Low output, hesitation and poor acceleration.	
													7	Surging.	
													8	Engine does not return to idle.	
													9	Dieseling (Run-on).	
													10	Afterburning in exhaust system.	
													11	Knocking.	
													12	Excessive engine oil consumption.	
													13	Excessive fuel consumption.	
													TROUBLE No.		
1	2	3	4	5	6	7	8	9	10	11	12	13			
○														STARTER	
△														● Defective battery-to-starter harness.	
△														● Defective starter switch.	
○	△													● Defective inhibitor switch.	
														● Defective starter.	
⊙														BATTERY	
⊙														● Poor terminal connection.	
○														● Run-down battery.	
	⊙	⊙	⊙	⊙	⊙	⊙	⊙	⊙	⊙	⊙		⊙		● Defective charging system.	
														MPFI SYSTEM (See Chap. 2-7.)	
	○	○	○	⊙	⊙	⊙	⊙	⊙	⊙	⊙		⊙		IGNITION SYSTEM	
	○	⊙		○	○	○			△			△		● Incorrect ignition timing.	
	○			△	○	○								● Disconnection of spark plug cord.	
	○			△	△	△								● Defective ignition coil.	
		○		○	○	○			⊙					● Defective cord or wiring.	
	○	○	○	⊙	○	⊙	△		○	○				● Defective spark plug.	
1	2	3	4	5	6	7	8	9	10	11	12	13	● Incorrect cam timing.		

TROUBLE No.													POSSIBLE CAUSE	
1	2	3	4	5	6	7	8	9	10	11	12	13		
														INTAKE SYSTEM
		○	○	⊙	○	○	⊙	○	○				⊙	● Improper idle adjustment.
			○	⊙	⊙	⊙			△	⊙				● Loosened or cracked intake boot.
			○	⊙	⊙	⊙			△	⊙				● Loosened or cracked intake duct.
			△	⊙	⊙	⊙			△	⊙	⊙			● Loosened or cracked blow-by hose.
			△	○	○	○	○		○	⊙				● Loosened or cracked vacuum hose.
			△	○	○	○				⊙				● Defective air cleaner gasket.
		○	○	○	○	○				⊙				● Defective intake manifold gasket.
		○	○	○	○	○				⊙				● Defective throttle body gasket.
				△	○	○			○	○	○			● Defective PCV valve.
				○	○	○			△	○	△			● Loosened oil filler cap.
			△	△	⊙	○				○		⊙		● Dirty air cleaner element.
														FUEL LINE
	⊙	△		△	○	○								● Defective fuel pump.
		△	△	△	○	○								● Clogged fuel line.
	○	○	○	○	△	△								● Lack of or insufficient fuel.
														BELT
	○	○	○											● Defective.
	○	○	○	△	○	○			○	○		○		● Defective timing.
														FRICTION
△														● Seizure of crankshaft and connecting-rod bearing.
△														● Seized camshaft.
△														● Seized or stuck piston and cylinder.
														COMPRESSION
	△	△	△	○	○	○			○	△		○		● Incorrect valve clearance.
	△	△	△	○	○	△			△			△		● Loosened spark plugs or defective gasket.
	△	△	△	○	○	△			△			△		● Loosened cylinder head nuts or defective gasket.
	△	△	△	○	○	△			○			○		● Improper valve seating.
	△	△	△	△	△	△			△		⊙	△		● Defective valve stem.
	○	○	○	○	○	△			△			△		● Worn or broken valve spring.
	△	△	△	○	△	△			△		⊙	○		● Worn or stuck piston rings, cylinder and piston.
	○	○	○	⊙	⊙	⊙			⊙	○		○		● Incorrect valve timing.
	○	○	○	○	○	○								● Improper engine oil (low viscosity).
1	2	3	4	5	6	7	8	9	10	11	12	13		

TROUBLE No.													POSSIBLE CAUSE
1	2	3	4	5	6	7	8	9	10	11	12	13	
													LUBRICATION SYSTEM
				○	○				△			△	● Incorrect oil pressure.
											○		● Loosened oil pump attaching bolts and defective gasket.
											○		● Defective oil filter seal.
											○		● Defective crankshaft oil seal.
				△							○		● Defective rocker cover gasket.
											○		● Loosened oil drain plug or defective gasket.
											○		● Loosened oil pan fitting bolts or defective oil pan.
													COOLING SYSTEM
				△	△	○		○		○			● Overheating.
					△				△			△	● Over cooling.
													TURBOCHARGER
				△	⊙	⊙						○	● Malfunction of turbocharger.
					⊙	⊙				⊙		○	● Malfunction of waste gate valve.
												○	● Defective oil pipe and hose.
													OTHERS
				⊙	⊙	△				△			● Malfunction of Evaporative Emission Control System. (See Chap. 2-1.)
				○			⊙						● Stuck or damaged throttle valve.
				△			○	○				○	● Accelerator cable out of adjustment.
1	2	3	4	5	6	7	8	9	10	11	12	13	

2. Engine Noise

Valve lash adjusters may make clicking noise once engine starts. It is normal if clicking noise ceases after a few minutes.

If clicking noise continues after a few minutes, check engine oil level and add oil if necessary. Warm up engine, then drive car at approximately 3,000 rpm for twenty minutes. If noise still exists, conduct troubleshooting procedures in accordance with the following table.

Type of sound	Condition	Possible cause
Regular clicking sound.	Sound increases as engine speed increases.	Valve mechanism is defective <ul style="list-style-type: none"> ● Broken lash adjuster. ● Worn valve rocker. ● Worn camshaft. ● Broken valve spring.
Heavy and dull metallic knock.	Oil pressure is low.	<ul style="list-style-type: none"> ● Worn crankshaft main bearing. ● Worn connecting rod bearing (big end).
	Oil pressure is normal.	<ul style="list-style-type: none"> ● Loose flywheel mounting bolts. ● Damaged engine mounting.
High-pitched metallic knock. (Engine knocking)	Sound is noticeable when accelerating with an overload.	<ul style="list-style-type: none"> ● Ignition timing advanced. ● Accumulation of carbon inside combustion chamber. ● Wrong spark plug. ● Improper gasoline.
Metallic knock when engine speed is medium (1,000 to 2,000 rpm).	Sound is reduced when* spark plug in noisy cylinder is shortened out.	<ul style="list-style-type: none"> ● Worn crankshaft main bearing. ● Worn bearing at crankshaft end of connecting rod.
Knocking sound when engine is operating under idling speed and engine is warm.	Sound is reduced when* spark plug in noisy cylinder is shortened out.	<ul style="list-style-type: none"> ● Worn cylinder liner and piston ring. ● Broken or stuck piston ring. ● Worn piston pin and hole at piston end of connecting rod.
Squeaky sound.	—	<ul style="list-style-type: none"> ● Insufficient alternator lubrication.
Rubbing sound.	—	<ul style="list-style-type: none"> ● Defective alternator brush and rotor contact.

Type of sound	Condition	Possible cause
Gear scream when starting engine.	—	<ul style="list-style-type: none"> ● Defective ignition starter switch. ● Worn gear and starter pinion.
Sound like polishing glass with a dry cloth.	—	<ul style="list-style-type: none"> ● Loose drive belt. ● Defective water pump shaft.
Hissing sound.	—	<ul style="list-style-type: none"> ● Loss of compression. ● Air leakage in air intake system, hoses, connections or manifolds.
Timing belt noise.	—	<ul style="list-style-type: none"> ● Loose timing belt. ● Belt contacting case/adjacent part.

*:Disconnect fuel injector connector at noisy cylinder.

SUBARU®

1992

**SERVICE
MANUAL**

	Page
M MECHANISM AND FUNCTION	2
1. General	2
2. Lubrication Lines	4
3. Oil Pump	6
4. Oil Filter	7
5. Oil Pan & Oil Strainer	7
6. Oil Pressure Switch	7
7. Oil Cooler	8
S SPECIFICATION AND SERVICE DATA	9
C COMPONENT PARTS	10
1. Oil Pump	10
W SERVICE PROCEDURE	12
1. Oil Pump	12
2. Oil Cooler	15
T TROUBLESHOOTING	16



M MECHANISM AND FUNCTION

1. General

1. SOHC MODEL

The lubrication system is a full-flow, filtering type. The oil pump utilizes a thin, large-diameter trochoid design to accommodate the high engine output. It is directly driven by the crankshaft.

Engine oil flow is regulated by the relief valve built into the oil pump. It is then delivered to the journal bearings, connecting rod bearings, etc., via the oil passage (on

the lower right side of the cylinder block), oil filter, and the oil gallery (on the right of the cylinder block) to provide proper lubrication.

Engine oil is also fed under pressure to the cylinder head valve mechanism after the flow is regulated by the orifice provided in the oil gallery. The rocker shaft has a built-in relief valve on the end so proper oil pressure is delivered to the hydraulic lash adjusters.

The oil pan is provided with baffle plates to eliminate the effect of oil suction caused by oil level variations during operation.

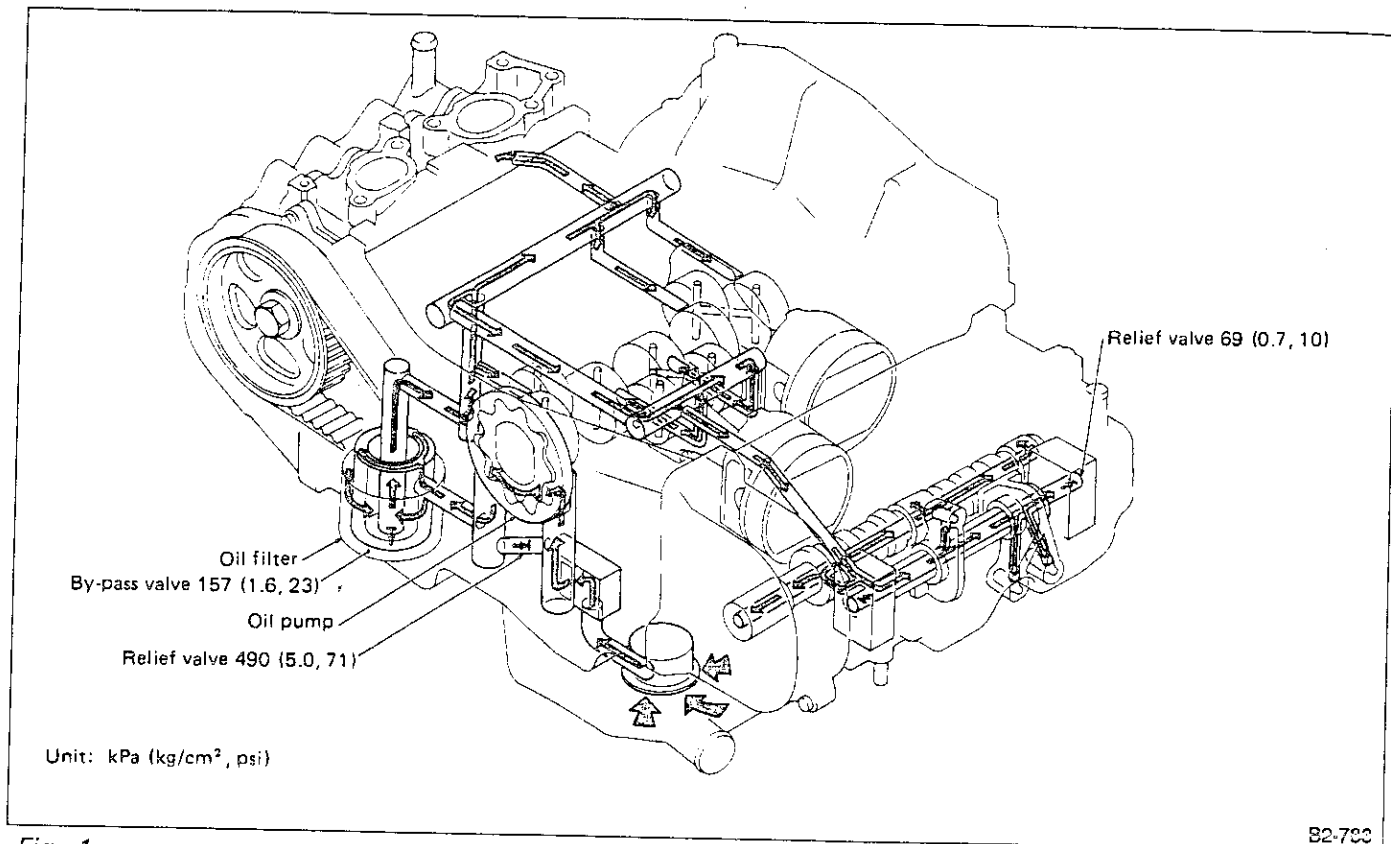


Fig. 1

2. DOHC MODEL

The lubrication system is a full-flow, filtering type. The oil pump uses a thin, large-diameter, trochoid design to match high engine output and is directly driven by the crankshaft.

A water-cooled, oil cooler is located between the oil filter and cylinder block to maintain an optimum engine oil temperature and prevent the degradation of lubrication performance.

Engine oil is pressure-regulated by the relief valve inside the oil pump and is delivered to the oil cooler via the oil gallery on the lower side of the right-hand cylinder block. After engine oil is cooled by the oil cooler, it is filtered by the oil filter and is then delivered to the oil gallery inside the right-hand cylinder block. From the oil gallery, the engine oil is distributed to the left and right

main galleries to lubricate the main bearings and various functional parts. Part of the oil delivered to the main bearings is delivered to the connecting rod bearings via the oil passages in the crankshaft, while part of the oil is injected into the inner walls of the cylinders and pistons for proper lubrication.

The valve mechanism on the cylinder head is also lubricated by engine oil under pressure which is regulated for the flow rate at the orifice.

A relief valve is built into the H.L.A. gallery to deliver stabilized oil pressure to the hydraulic lash adjusters.

The front camshaft bearings are lubricated by engine oil delivered through the oil galleries in the camshafts. The oil pan is provided with baffle plates, preventing oil from being drawn in by changes in the oil level.

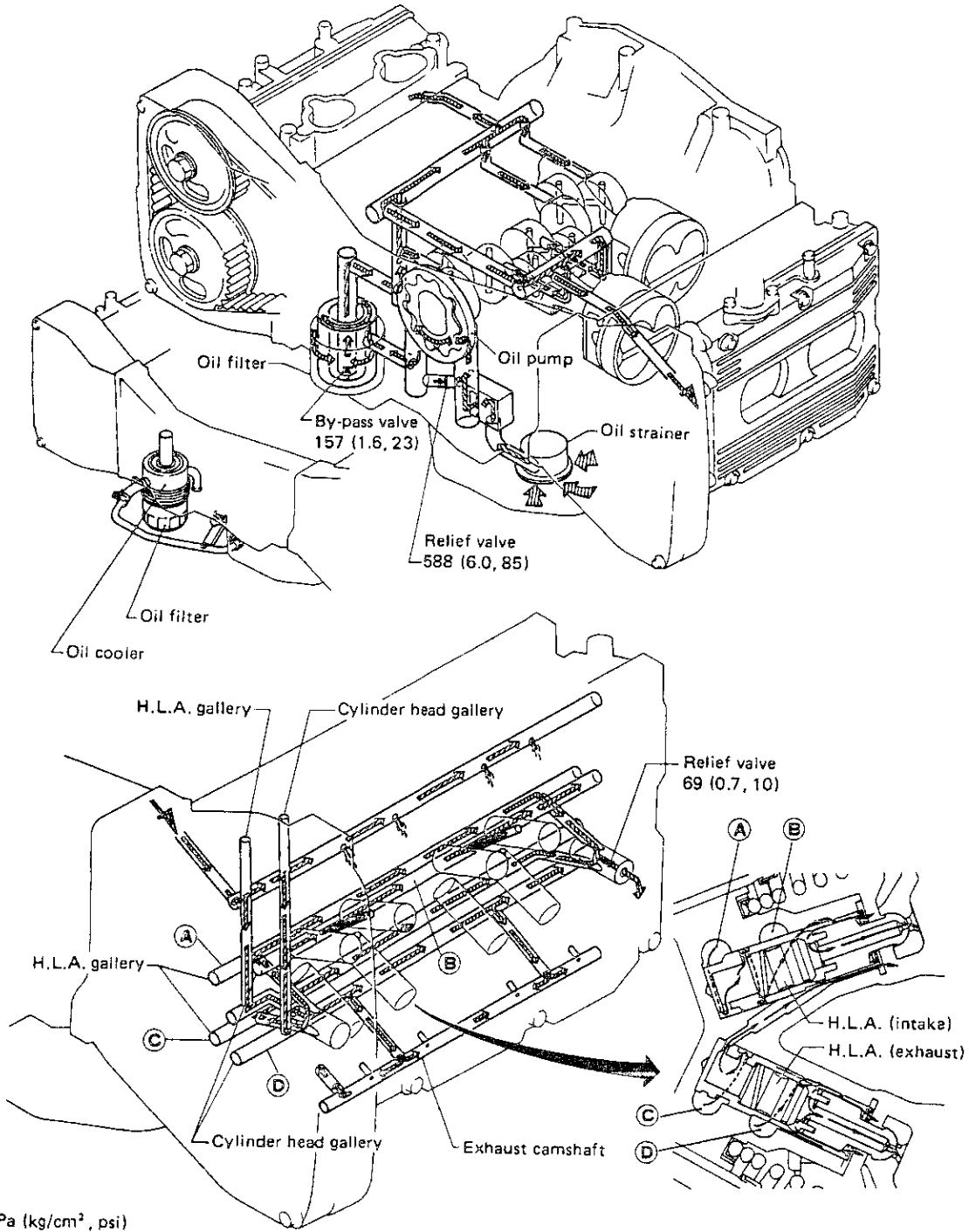


Fig. 2

B2-970

2. Lubrication Lines

1. SOHC MODEL

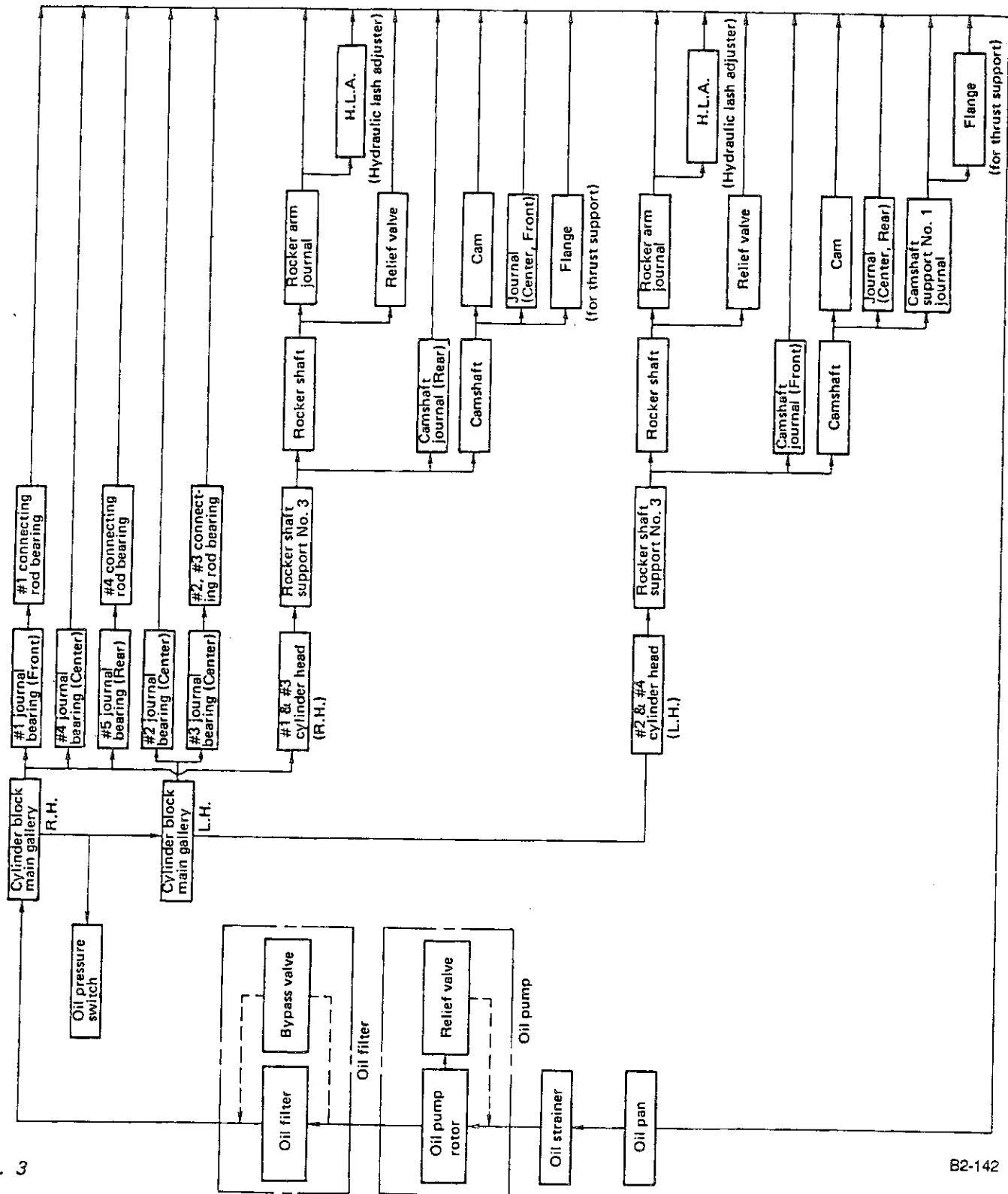


Fig. 3

B2-142

2. DOHC MODEL

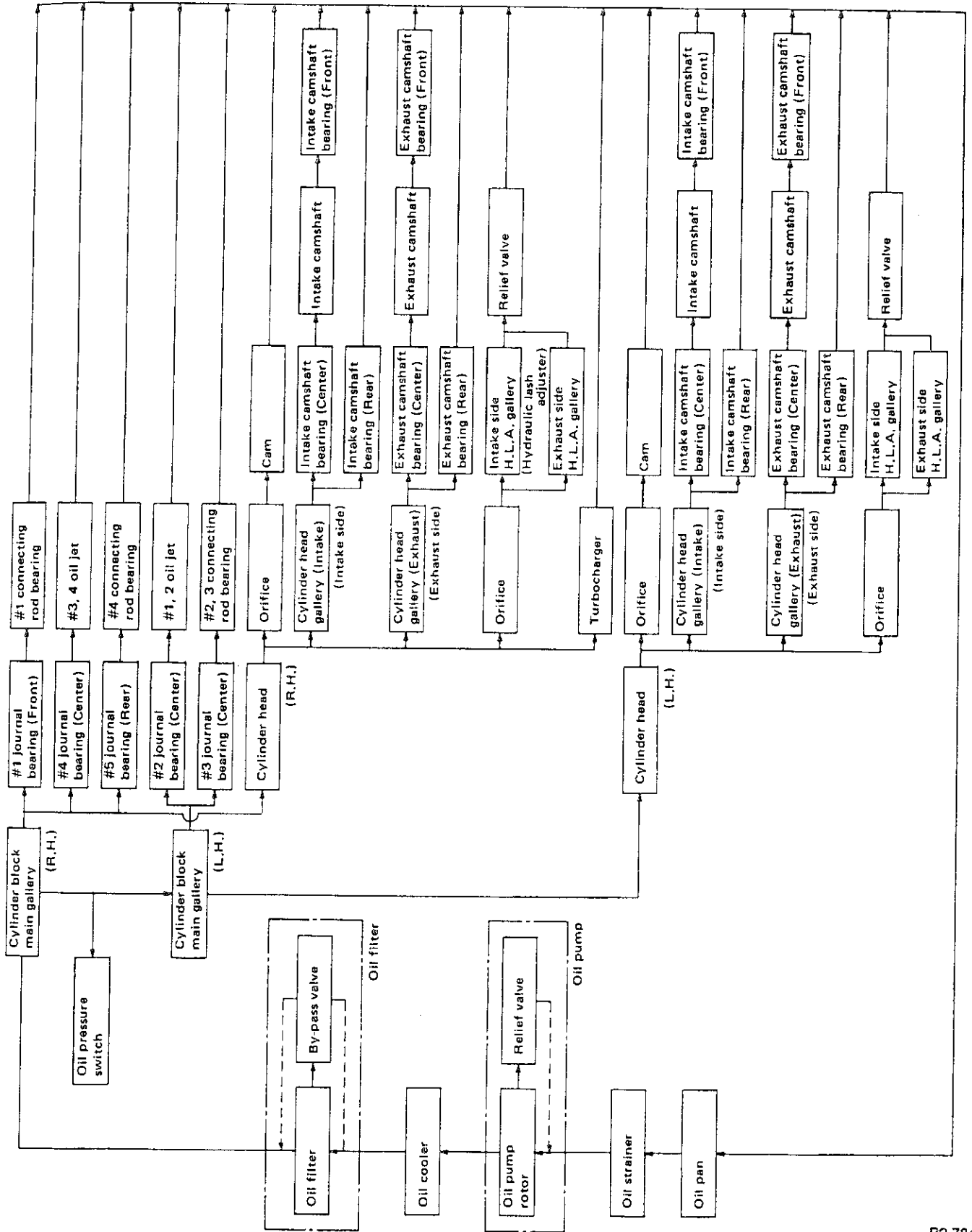


Fig. 4

3. Oil Pump

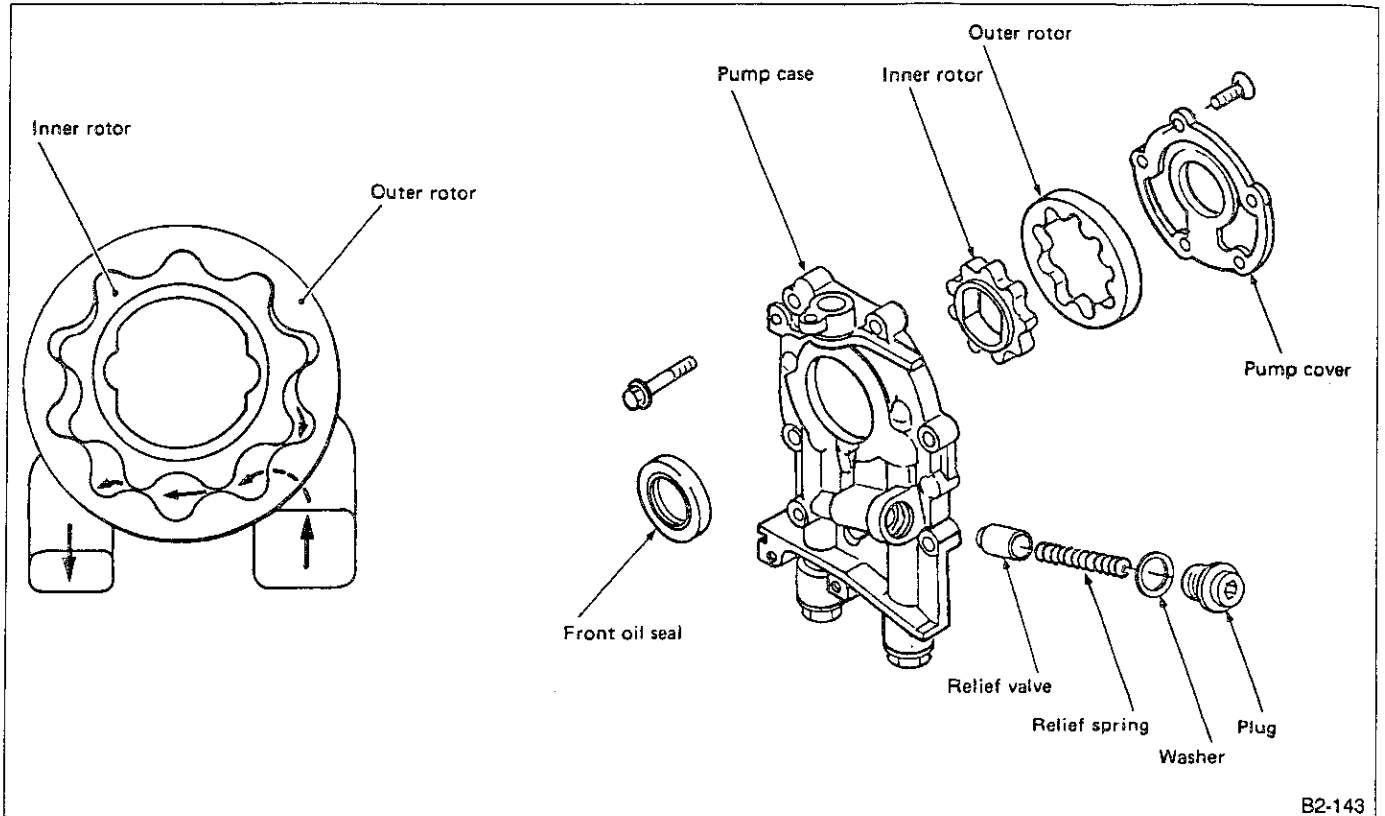


Fig. 5

The trochoid oil pump utilizes an internal oil circulation design which is accomplished by an inner rotor and outer rotor built into the pump body. When the inner rotor is driven by the crankshaft, the outer rotor is rotated, changing the size of the space between the two rotors (because of the different number of teeth used on the rotors).

Engine oil is sucked into the large space created near the inlet side. It is then carried over to the discharge port and discharged due to it being gradually pressurized as the space carrying it becomes smaller. Oil pressure is regulated by the relief valve located on the discharge side. Excess oil is directly returned to the suction port.

4. Oil Filter

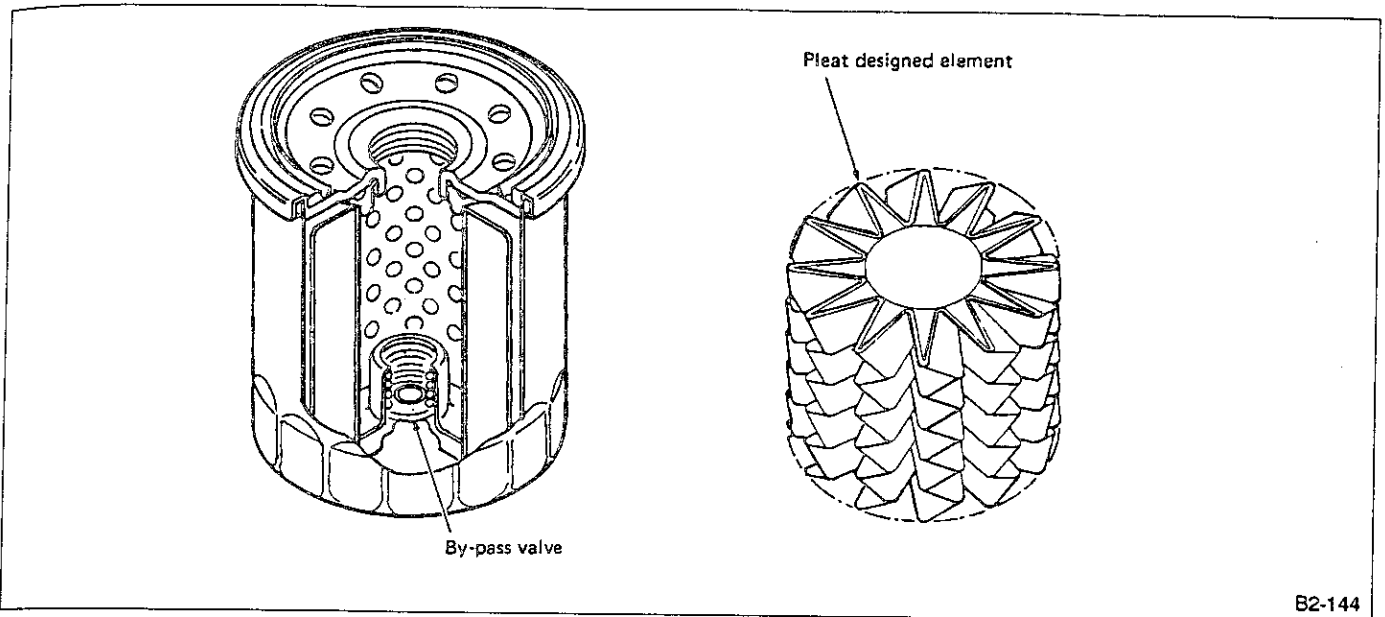


Fig. 6

B2-144

The oil filter is a full-flow cartridge type that utilizes a paper element. It also has a built-in bypass valve. The filter element has a special pleat design to increase the effective filtering area.

5. Oil Pan & Oil Strainer

The oil pan is joined to the cylinder block via liquid gasket. The oil strainer is a metal net type and removes large foreign particles from the engine oil. It is located in the middle of the oil pan. The pipe from the strainer is connected to the suction port on the left side of the cylinder block.

Baffle plates are placed in the oil pan and the lower side of the cylinder block to stabilize the oil level and strengthen the oil pan.

6. Oil Pressure Switch

A: CONSTRUCTION

The oil pressure switch is located on the front right upper portion of the cylinder block. The purpose of this switch is to monitor the operation of the oil pump as well as the lubricating oil pressure when the engine is running.

B: FUNCTION

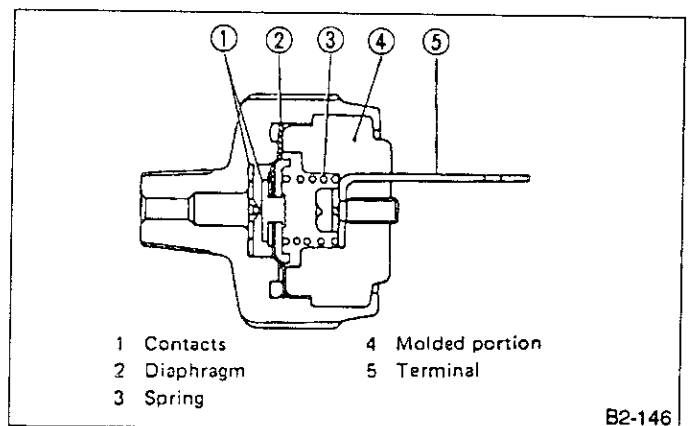


Fig. 7

B2-146

1) When oil pressure does not build up (with ignition switch "ON"):

The diaphragm is pushed toward the cylinder block by spring force (equivalent to the specified oil pressure). This closes the contact point to illuminate the oil pilot lamp on the instrument panel.

2) When oil pressure reaches the specified value (after engine starts):

After oil pressure reaches the specified value of [14.7 kPa (0.15 kg/cm², 2.1 psi)], the diaphragm, pushed by oil pressure, overcomes the spring force. This opens the contact point to turn the oil pilot lamp off.

7. Oil Cooler (DOHC model only)

The oil cooler used in DOHC models is of a water cooled type. It serves to maintain engine oil in proper temperature range and so prevent degradation of lubricating oil performance.

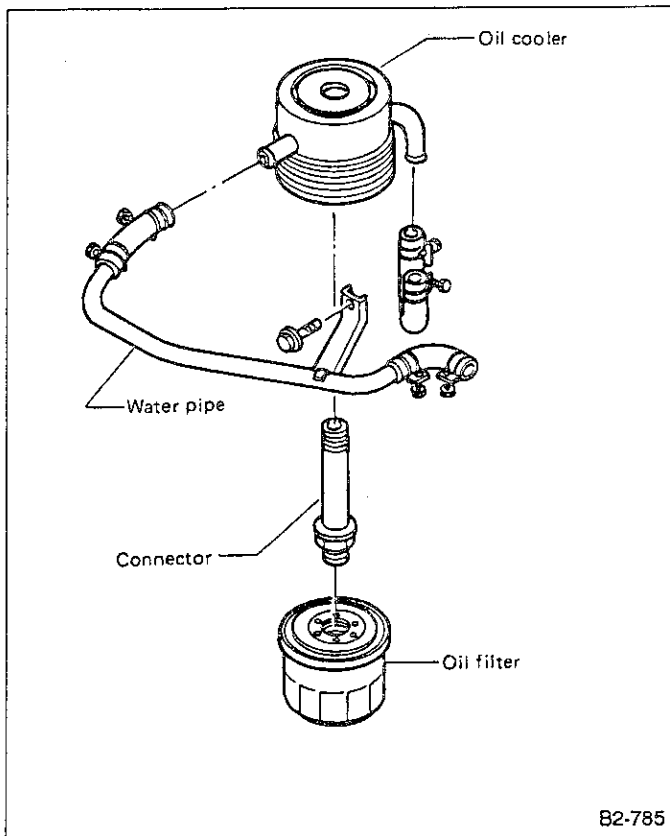


Fig. 8

S SPECIFICATIONS AND SERVICE DATA

A: SPECIFICATIONS

ITEM	MODEL			SOHC		DOHC	
Lubrication method				Forced lubrication			
Oil pump	Pump type			Trochoid type			
	Number of teeth	Inner rotor		9			
		Outer rotor		10			
	Outer rotor diameter x thickness			78 x 9 (3.07 x 0.35)		78 x 10 (3.07 x 0.39)	
	Tip clearance between inner and outer rotor		mm (in)	STD	0.04 — 0.14 (0.0016 — 0.0055)		
				LIM	0.18 (0.0071)		
	Side clearance between inner rotor and pump case		mm (in)	STD	0.02 — 0.07 (0.0008 — 0.0028)		
				LIM	0.12 (0.0047)		
	Case clearance between outer rotor and pump case		mm (in)	STD	0.10 — 0.175 (0.0039 — 0.0069)		
				LIM	0.20 (0.0079)		
	Capacity at 80°C (176°F)	600 rpm	Discharge	- pressure	98 kPa (1.0 kg/cm ² , 14 psi)		
				- quantity	4.2 ℓ (4.4 US qt, 3.7 Imp qt)/min.		4.6 ℓ (4.9 US qt, 4.0 Imp qt)/min.
		5,000 rpm	Discharge	- pressure	294 kPa (3.0 kg/cm ² , 43 psi)		
- quantity				42.0 ℓ (11.10 US gal, 9.24 Imp gal)/min.		47.0 ℓ (12.42 US gal, 10.34 Imp gal)/min.	
Relief valve operation pressure				490 kPa (5.0 kg/cm ² , 71 psi)		588 kPa (6.0 kg/cm ² , 85 psi)	
Oil filter	Type			Full-flow filter type			
	Filtration area			1,000 cm ² (155 sq in)			
	By-pass valve opening pressure			156 kPa (1.6 kg/cm ² , 23 psi)			
	Outer diameter x width			80 x 70 (3.15 x 2.76)			
	Oil filter to engine thread size			M 20 x 1.5			
Oil cooler	Type			—		Water cooled type	
	Core dimensions			mm (in)		93 dia. x 10 (3.66 dia. x 0.39)	
Relief valve (for hydraulic lash adjuster) operation pressure				69 kPa (0.7 kg/cm ² , 10 psi)			
Oil pressure switch	Type			Immersed contact point type			
	Working voltage — wattage			12 V — 3.4 W or less			
	Warning light activation pressure			14.7 kPa (0.15 kg/cm ² , 2.1 psi)			
	Proof pressure			More than 981 kPa (10 kg/cm ² , 142 psi)			
Oil capacity (at replacement)				4.5 ℓ (4.8 US qt, 4.0 Imp qt)		5.2 ℓ (5.5 US qt, 4.6 Imp qt)	

C COMPONENT PARTS

1. Oil Pump

1. SOHC MODEL

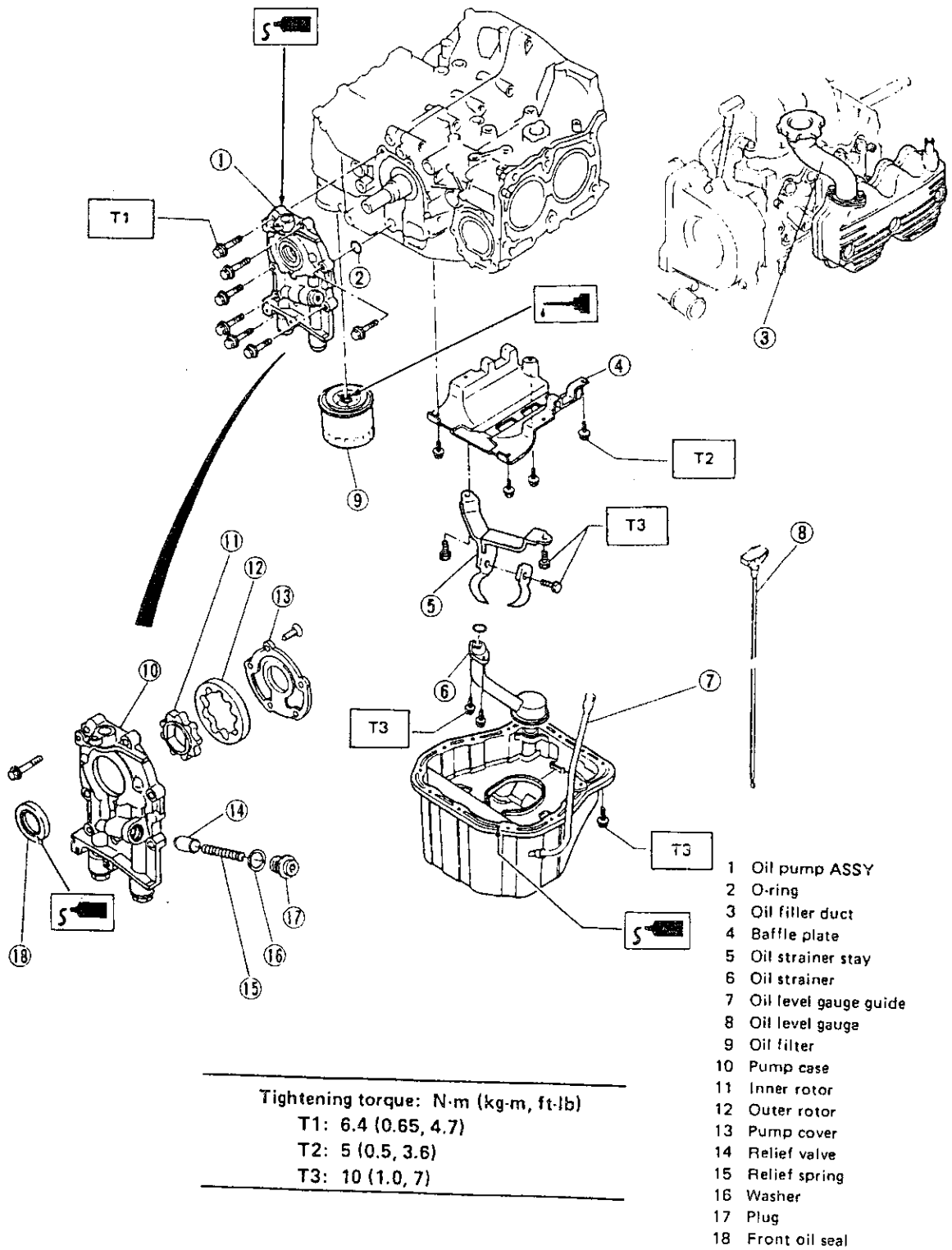
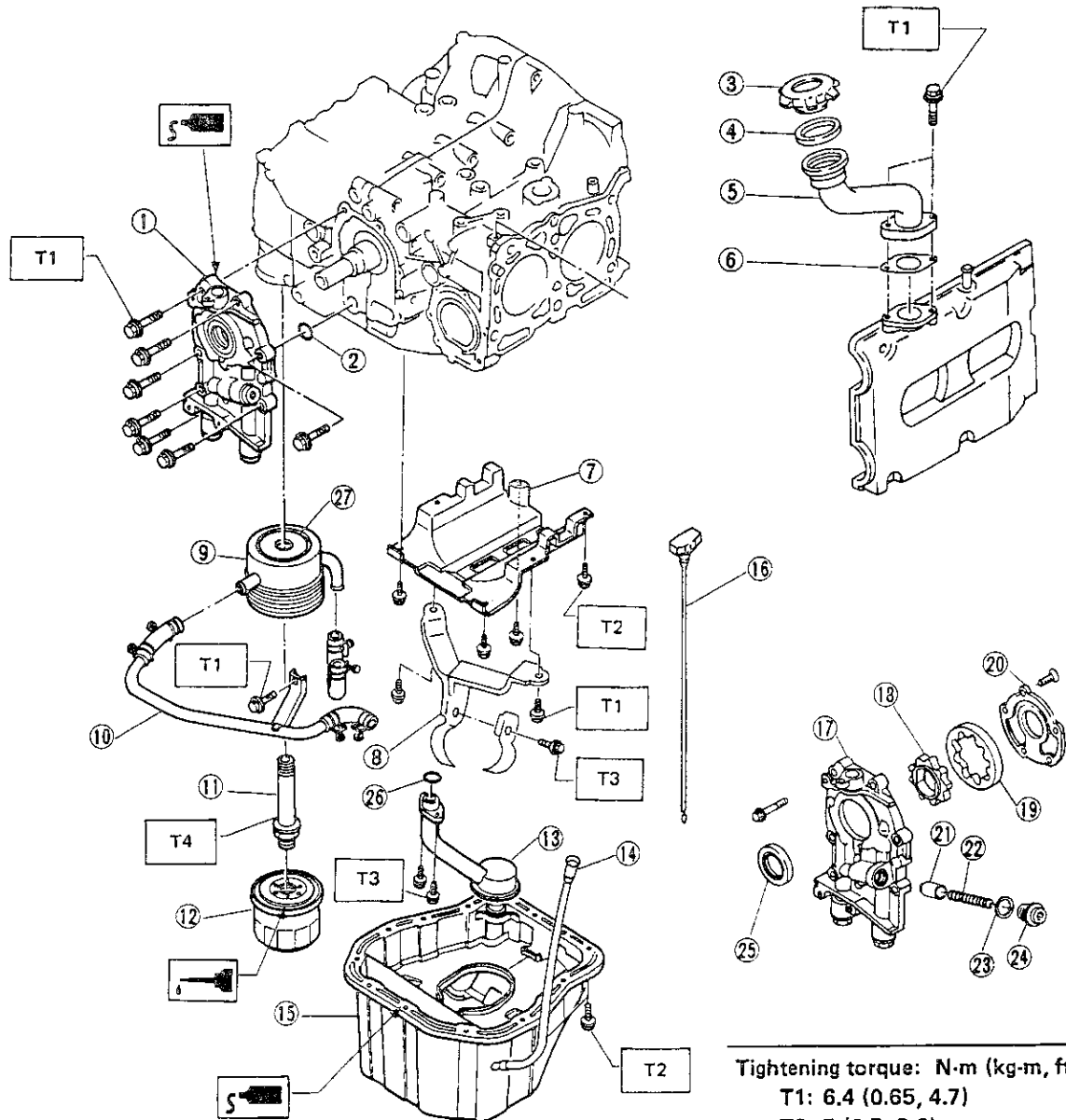


Fig. 9

2. DOHC MODEL



- | | | |
|---------------------|--------------------------|-------------------|
| 1 Oil pump ASSY | 10 Water pipe | 19 Outer rotor |
| 2 O-ring | 11 Connector | 20 Pump cover |
| 3 Oil filler cap | 12 Oil filter | 21 Relief valve |
| 4 Gasket | 13 Oil strainer | 22 Relief spring |
| 5 Oil filler duct | 14 Oil level gauge guide | 23 Washer |
| 6 Gasket | 15 Oil pan | 24 Plug |
| 7 Baffle plate | 16 Oil level gauge | 25 Front oil seal |
| 8 Oil strainer stay | 17 Pump case | 26 O-ring |
| 9 Oil cooler | 18 Inner rotor | 27 O-ring |

Tightening torque: N·m (kg·m, ft·lb)
T1: 6.4 (0.65, 4.7)
T2: 5 (0.5, 3.6)
T3: 10 (1.0, 7)
T4: 49 – 59 (5.0 – 6.0, 36 – 43)

Fig. 10

W SERVICE PROCEDURE

1. Oil Pump

A: REMOVAL

- 1) Drain engine oil
- 2) Drain coolant
- 3) Remove belt covers, drive belt and related parts. (Refer to "2-3 ENGINE")
- 4) Remove belt tensioner bracket.
- 5) Remove water pump.
- 6) Remove oil pump.

Insert a standard screwdriver as shown in Figure 11.

Be careful not to scratch mating surfaces of cylinder block and oil pump.

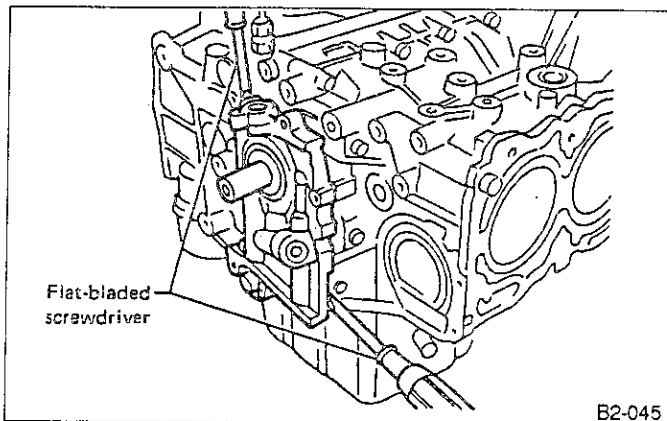


Fig. 11

B: DISASSEMBLY

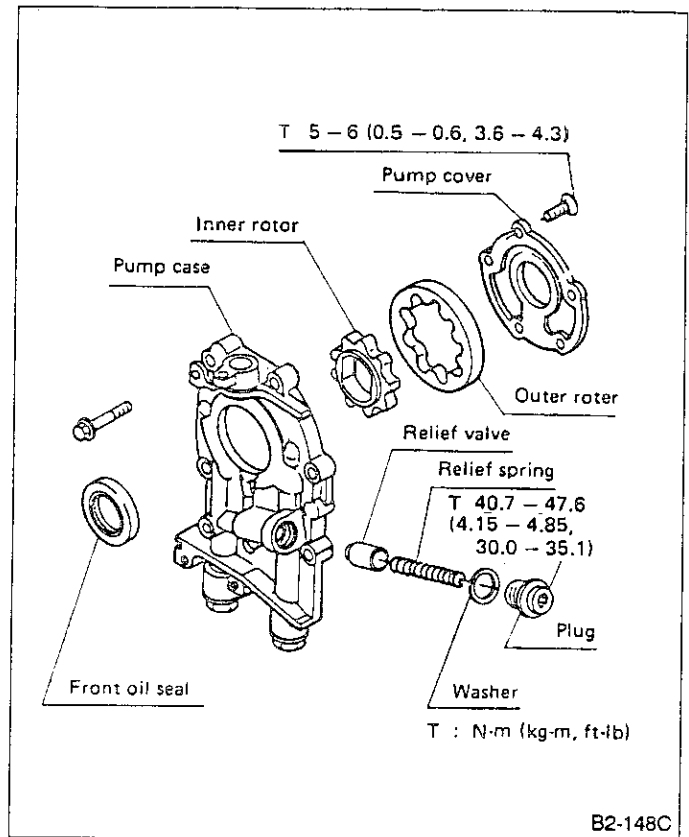


Fig. 12

Remove screws which secure oil pump cover and disassemble oil pump.

Inscribe alignment marks on inner and outer rotors so that they can be replaced in their original positions during reassembly.

Before removing relief valve, loosen plug when removing oil pump from cylinder block.

C: INSPECTION**1. TIP CLEARANCE**

Measure the tip clearance of rotors. If the clearance exceeds the limit, replace rotors as a matched set.

Tip clearance:**Standard**

0.04 — 0.14 mm (0.0016 — 0.0055 in)

Limit

0.18 mm (0.0071 in)

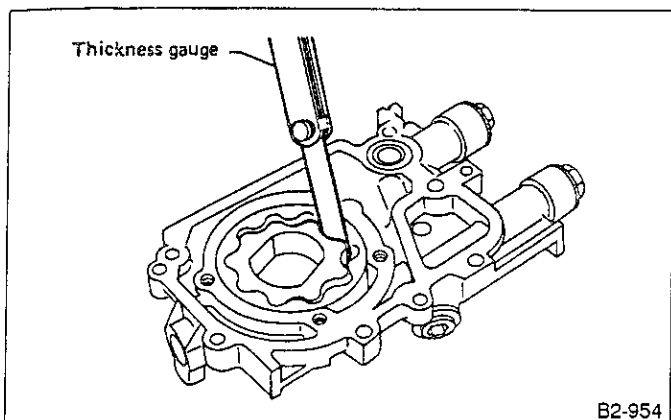


Fig. 13

2. CASE CLEARANCE

Measure the clearance between the outer rotor and the pump case. If the clearance exceeds the limit, replace the rotor or pump case.

Case clearance:**Standard**

0.10 — 0.175 mm (0.0039 — 0.0069 in)

Limit

0.20 mm (0.0079 in)

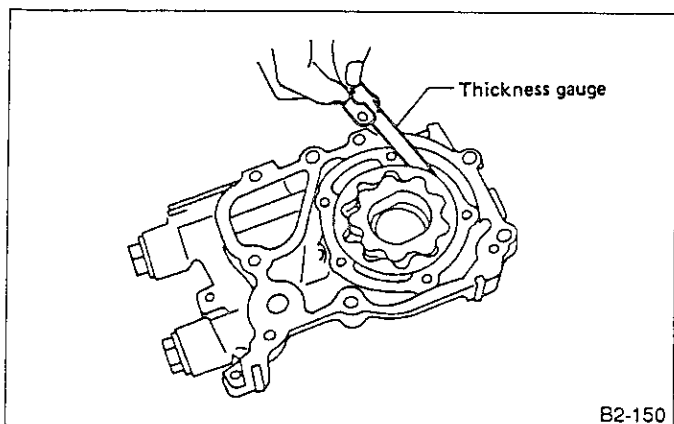


Fig. 14

3. SIDE CLEARANCE

Measure clearance between oil pump inner rotor and pump cover. If the clearance exceeds the limit, replace rotor or pump case.

Side clearance:**Standard**

0.02 — 0.07 mm (0.0008 — 0.0028 in)

Limit

0.12 mm (0.0047 in)

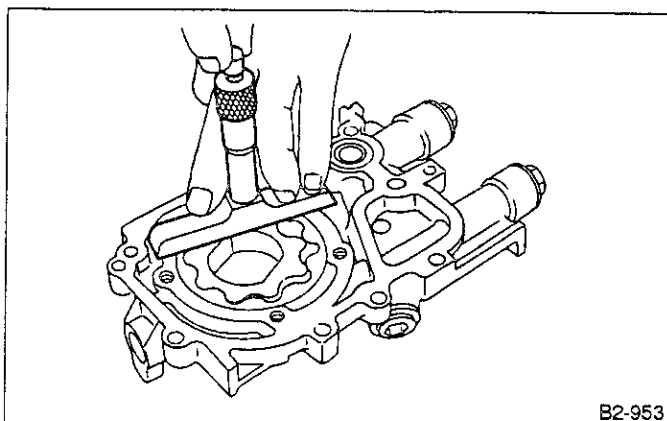


Fig. 15

4. OIL RELIEF VALVE

Check the valve for fitting condition and damage, and the relief valve spring for damage and deterioration. Replace the parts if defective.

Relief valve spring:**SOHC model****Free length**

71.8 mm (2.827 in)

Installed length

54.7 mm (2.154 in)

Load when installed

77.08 N (7.86 kg, 17.33 lb)

DOHC model**Free length**

73.7 mm (2.902 in)

Installed length

54.7 mm (2.154 in)

Load when installed

93.2 N (9.5 kg, 20.9 lb)

5. OIL PUMP CASE

Check the oil pump case for worn shaft hole, clogged oil passage, worn rotor chamber, cracks, and other faults.

6. OIL SEAL

Check the oil seal lips for deformation, hardening, wear, etc. and replace if defective.

D: ASSEMBLY

- 1) Install front oil seal.
- Use a new oil seal.

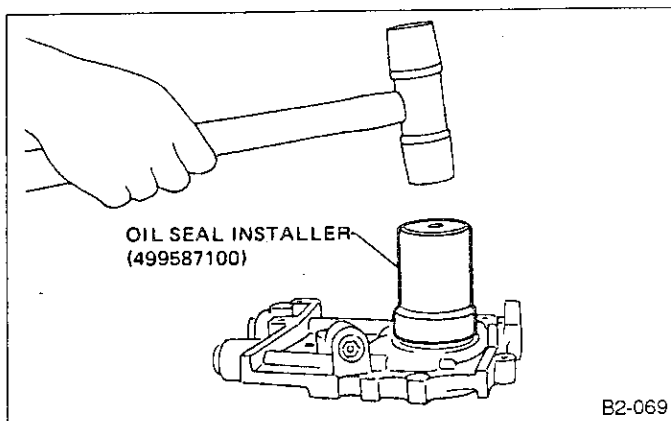


Fig. 16

- 2) Install inner and outer rotors in their original positions.
- 3) Install oil relief valve and relief spring.
- 4) Install oil pump cover.

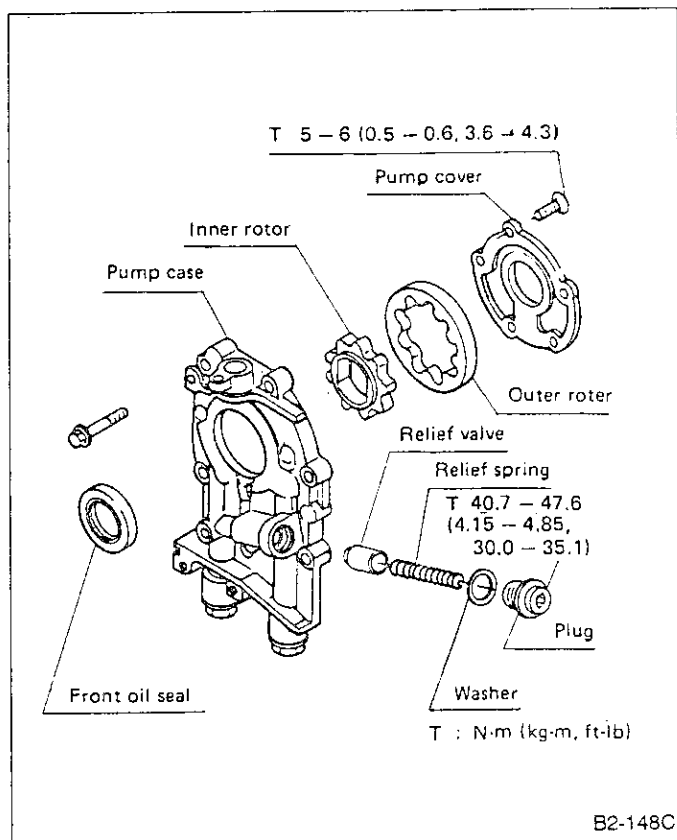


Fig. 17

E: INSTALLATION

Installation is in the reverse order of removal.

Observe the following:

- 1) Apply fluid packing to matching surfaces of pump.

Fluid packing:

Three bond 1215 or equivalent

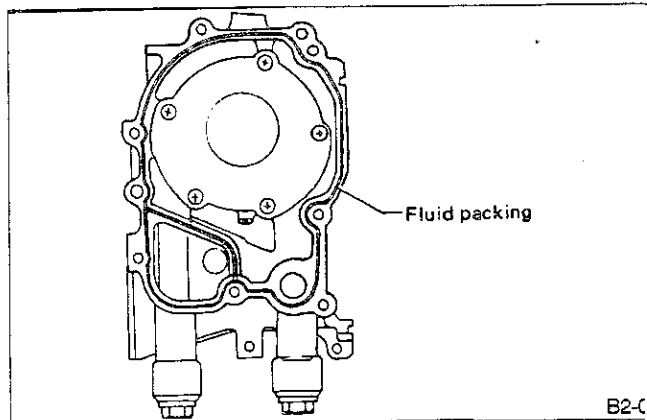


Fig. 18

- 2) Replace O-ring with a new one.
 - 3) Be careful not to scratch oil seal when installing pump on cylinder block.
- Apply liquid packing to oil pressure switch thre before installation.

2. Oil Cooler (DOHC model only)

A: REMOVAL

- 1) Remove front exhaust pipe.
Refer to "2-9 Exhaust system".
- 2) Remove water pipe.

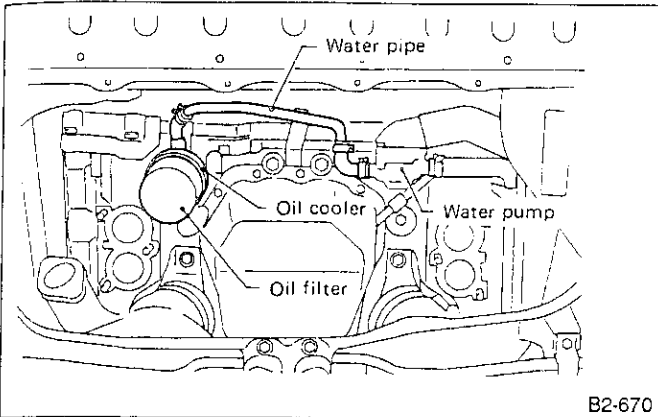


Fig. 19

- 3) Remove oil filter.
- 4) Remove connector and remove oil cooler.

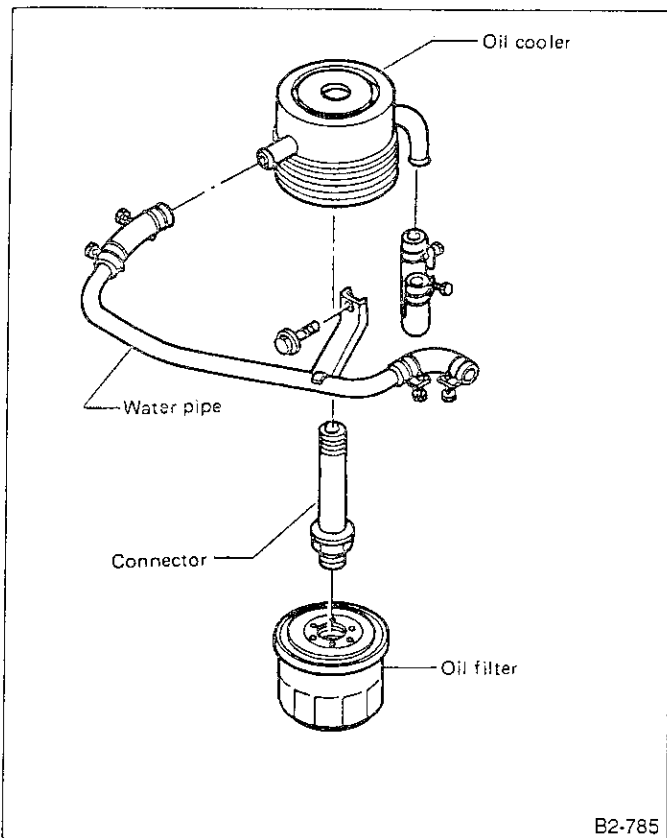


Fig. 20

B: INSPECTION

- 1) Check that coolant passages are not clogged using air-blow method.
- 2) Check mating surfaces of cylinder block. O-ring groove and oil filter for damage.

C: INSTALLATION

- 1) Install oil cooler on cylinder block with connector pipe.
- 2) Install oil filter.

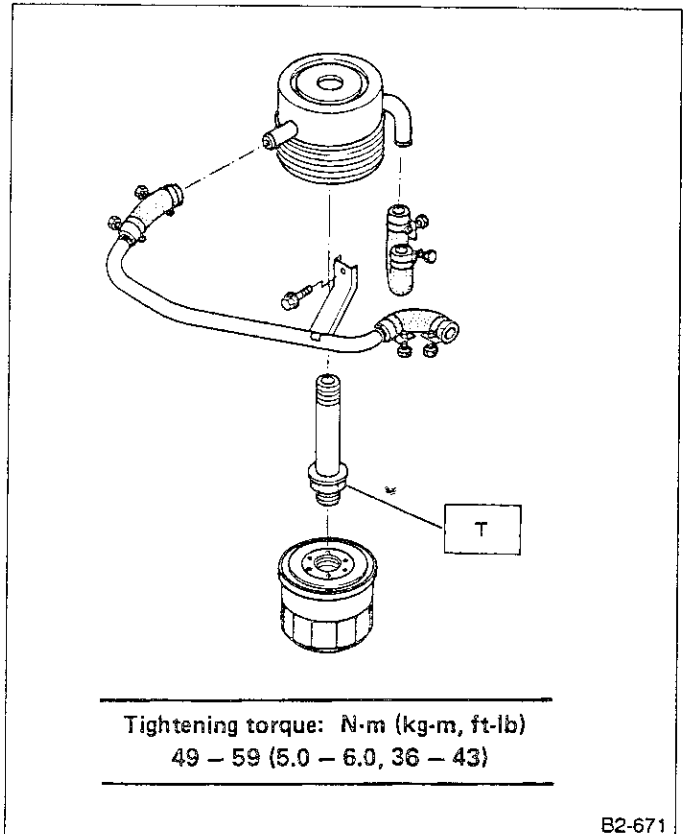


Fig. 21

Always use a new O-ring.

- 3) Install front exhaust pipe.
Refer to "2-9 Exhaust system".

T TROUBLESHOOTING

Before troubleshooting, make sure that the engine oil level is correct and no oil leakage exists.

Trouble	Possible cause	Corrective action	
1. Warning light remains on.	1) Oil pressure switch failure	Cracked diaphragm or oil leakage within switch	Replace.
		Broken spring or seized contacts	Replace.
	2) Low oil pressure	Clogged oil filter	Replace.
		Malfunction of oil by-pass valve of oil filter	Clean or replace.
		Malfunction of oil relief valve of oil pump	Clean or replace.
		Clogged oil passage	Clean.
		Excessive tip clearance and side clearance of oil pump rotor and gear	Replace.
		Clogged oil strainer or broken pipe	Clean or replace.
	3) No oil pressure	Insufficient engine oil	Replenish.
		Broken pipe of oil strainer	Replace.
Stuck oil pump rotor		Replace.	
2. Warning light does not go on.	1) Burn-out bulb	Replace.	
	2) Poor contact of switch contact points	Replace.	
	3) Disconnection of wiring	Repair.	
3. Warning light flickers momentarily.	1) Poor contact at terminals	Repair.	
	2) Defective wiring harness	Repair.	
	3) Low oil pressure	Check for the same possible causes as listed in 1.—2).	

SUBARU®

1992

**SERVICE
MANUAL**



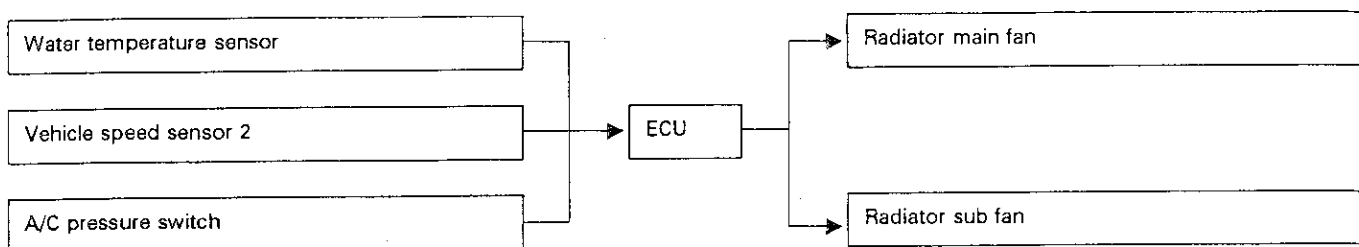
	Page
M MECHANISM AND FUNCTION	2
1. General	2
2. Cooling Lines	3
3. Water Pump	5
4. Mechanical Seal	6
5. Thermostat	6
6. Radiator Fan Switch (Carburetor model only)	6
7. Coolant Filler Tank	6
S SPECIFICATIONS AND SERVICE DATA	7
A: SPECIFICATIONS	7
B: SERVICE DATA	7
C COMPONENT PARTS	8
1. Water Pump	8
2. Radiator and Radiator Fan	10
W SERVICE PROCEDURE	12
1. Water Pump	12
2. Thermostat	14
3. Radiator	14
4. Radiator Cap (Filler Tank Cap on Turbo Model)	16
5. Radiator Fan and Fan Motor	16
6. Coolant Filler Tank	16
T TROUBLESHOOTING	17

M MECHANISM AND FUNCTION

1. General

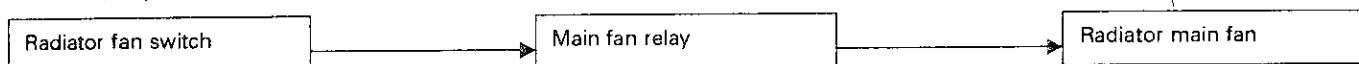
The engine cooling system consists of a cross-flow radiator which features high heat-dissipation performance, an radiator fan, a water pump, a thermostat, and a water temperature sensor. The reserve tank is designed to eliminate the need for replenishing coolant.

On models without an air conditioner, the ECU sends an ON or OFF switch signal to the radiator fan in response to signals from the water temperature sensor and vehicle speed sensor 2. On models with an air conditioner, the ECU sends ON or OFF, and Lo (low) or Hi (high) switch signals to the radiator main fan and sub fan in response to signals from the water temperature sensor, vehicle speed sensor 2 and A/C pressure switch. (As to sub fan, refer to chapter 4-7.)

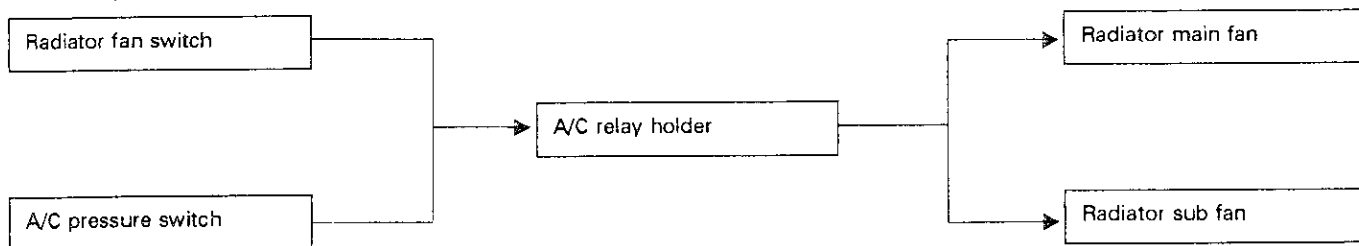


On carburetor model, radiator fan is operated by turning ON of radiator fan switch.

Without A/C system



With A/C system



2. Cooling Lines

1. Non-TURBO MODEL

This cooling system operates in three steps depending on the temperature of the coolant flowing through the cooling circuit.

1) 1st step ... With thermostat closed
At coolant temperature of below 76°C (169°F), the thermostat remains closed and the coolant flows through the bypass and heater circuits.

This permits the engine to warm up quickly.

2) 2nd step ... With thermostat opened
When the coolant temperature is above 76 — 80°C (169 — 176°F), the thermostat opens and the coolant flows through the radiator where it is cooled.

3) 3rd step ... With radiator fan operating
When the coolant temperature rises above 95°C (203°F), the water temperature sensor is turned on and the radiator fan rotates.

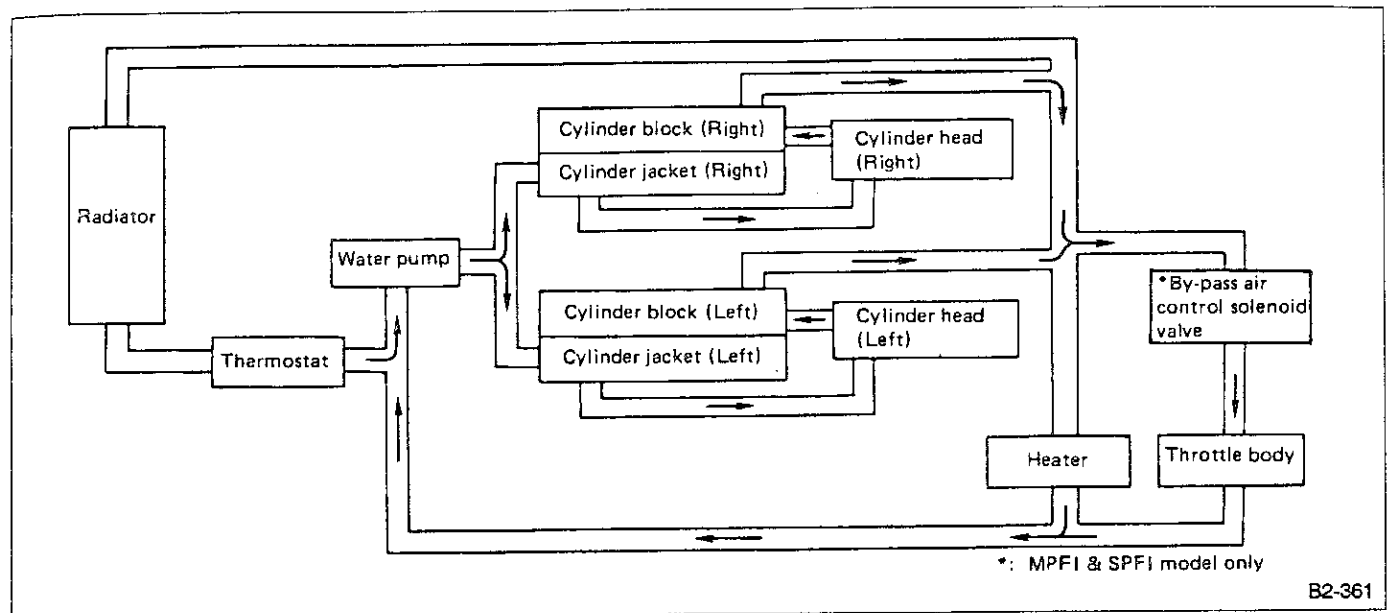


Fig. 1

2. TURBO MODEL

1) 1st step ... With thermostat closed

At coolant temperature of below 76°C (169°F), the thermostat remains closed and the coolant flows through the bypass and heater circuits.

This permits the engine to warm up quickly.

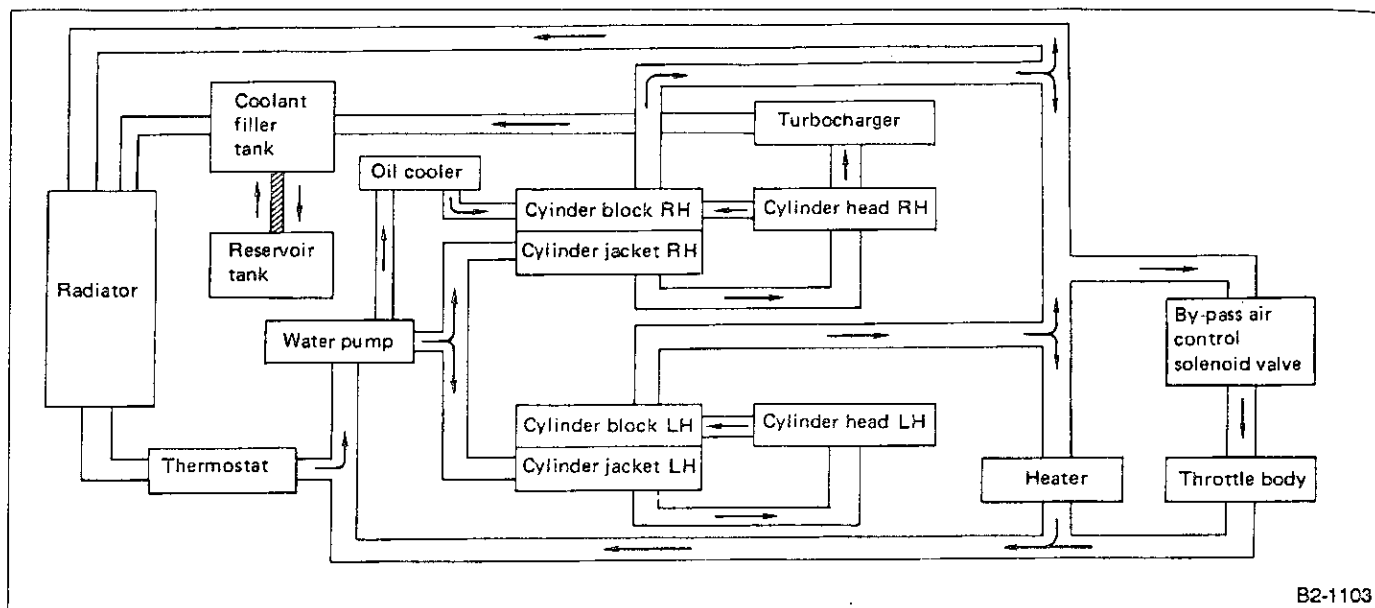
2) 2nd step ... With thermostat opened

When the coolant temperature is above 76 — 80°C (169 — 176°F), the thermostat opens and the coolant flows through the radiator where it is cooled.

3) 3rd step ... With radiator fan operating

When the coolant temperature rises above 95°C (203°F), the water temperature sensor is turned on and the radiator fan rotates.

4) When the engine is stopped after high-speed operations, vapor produced in the turbocharger cooling section is delivered from the coolant filler tank to the reservoir tank where it condenses back into water. Water is then absorbed by the coolant filler tank as the engine cools.



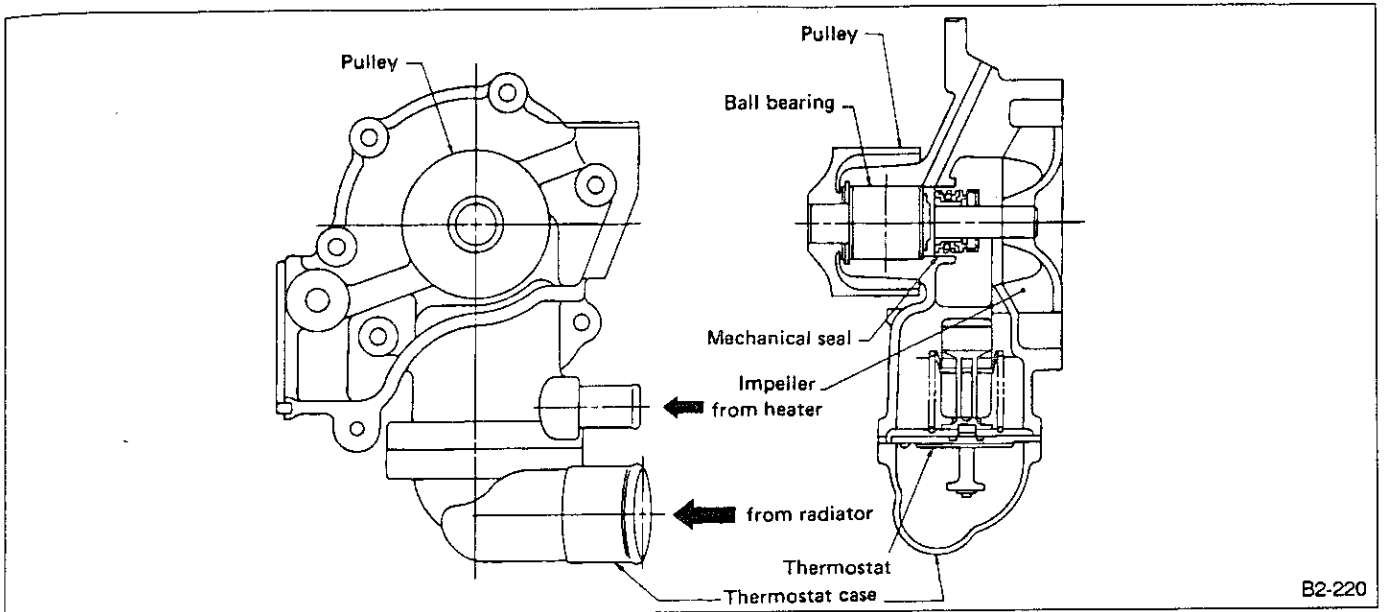
B2-1103

Fig. 2

3. Water Pump

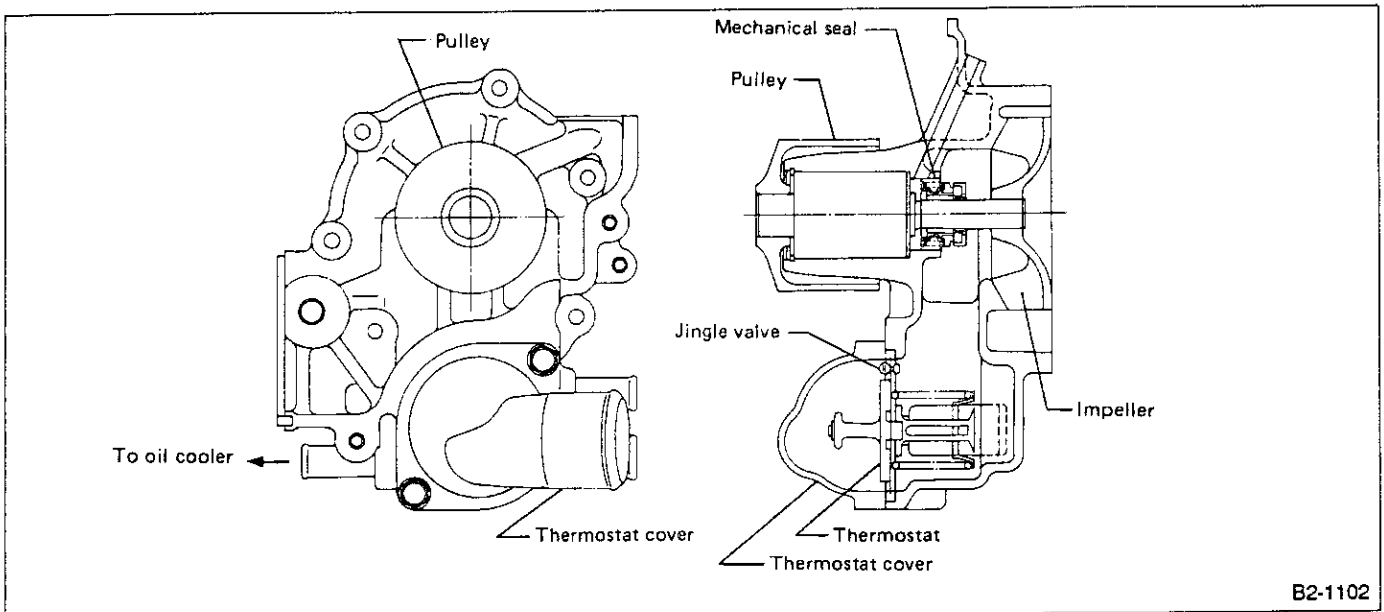
The water pump is located on the left front portion of the cylinder block and is driven by the back of the timing belt. The thermostat is built into the water inlet located on the lower side of the water pump. When the

impeller rotates, engine coolant is drawing into the water pump from the lower pipe (which is connected to the radiator hose) via the thermostat. It then flows along the perimeter of the impeller and is delivered to the engine's water passage.



B2-220

Fig. 3 Non-Turbo model



B2-1102

Fig. 4 Turbo model

4. Mechanical Seal

The mechanical seal has its seat pressed into the water pump shaft to form the seal and water pump as a single unit. With this design, the water pump cannot be disassembled.

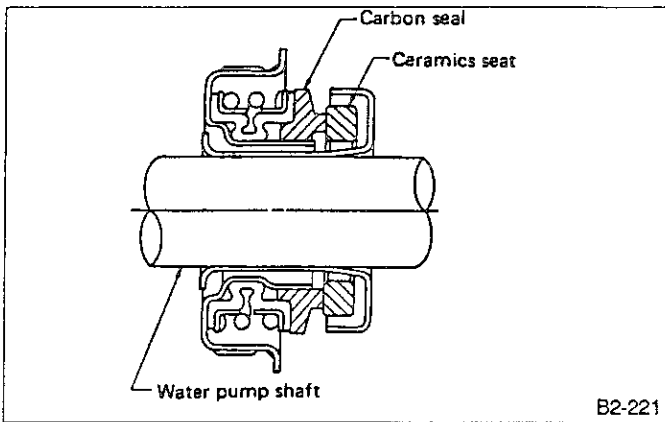


Fig. 5

5. Thermostat

The thermostat is powered to open the valve by a totally- enclosed wax pellet which expands with

increased temperature. It provides the sure open-close operation of the valve and features high durability.

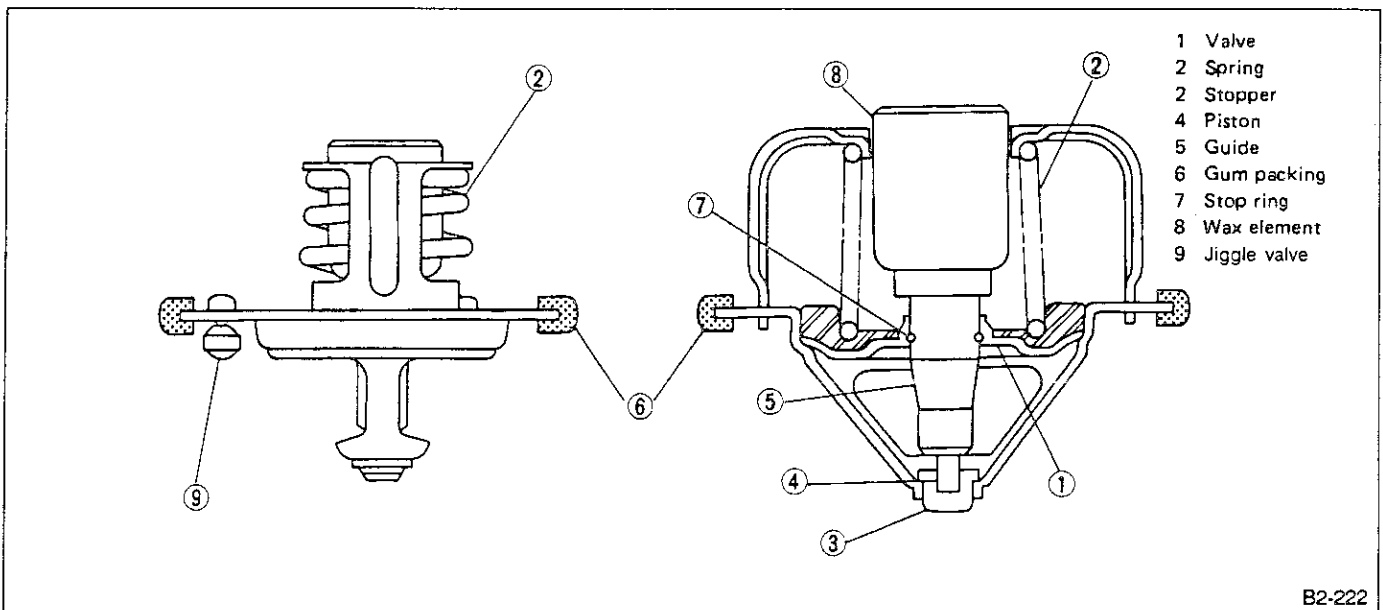


Fig. 6

6. Radiator Fan Switch (Carburetor model only)

This is of a type where the bimetal is built into the radiator fan switch. When coolant temperature is 90 to 94°C (194 to 201°F) or more, the switch is ON, and current flows through it to the radiator fan motor. When coolant temperature is 85 to 89°C (185 to 195°F) or less, the switch is turned OFF.

7. Coolant Filler Tank

On TURBO models, the radiator is not equipped with a coolant filler cap. The coolant filler tank, located above No. 1 cylinder, not only delivers coolant to the turbocharger, but also sends vapor produced in the turbocharger cooling section to the reservoir tank. This vapor condenses into water inside the reservoir tank and is then absorbed by the coolant filler tank.

S SPECIFICATIONS AND SERVICE DATA

A: SPECIFICATIONS

ITEM	MODEL	Non-Turbo				Turbo
		2200 cc	2000 cc	1800 cc	1600 cc	2000 cc
Cooling system		Electric fan + Forced cooling water circulation system				
Total coolant capacity		5.9 ℓ (6.2 US qt, 5.2 Imp qt)	6.0 ℓ (6.3 US qt, 5.3 Imp qt)	6.3 ℓ (6.7 US qt, 5.5 Imp qt)		7.2 ℓ (7.6 US qt, 6.3 Imp qt)
Water pump	Type	Centrifugal impeller type				
	Discharge performance I	Discharge	20 ℓ (5.3 US gal, 4.4 Imp gal) /min.			
		Pump speed — total water head	760 rpm — 0.3 mAq (1.0 ft Aq)			
		Water temperature	80°C (176°F)			
	Discharge performance II	Discharge	100 ℓ (26.4 US gal, 22.0 Imp gal) /min.			
		Pump speed — total water head	3,000 rpm — 5.0 mAq (16.4 ft Aq)			
		Water temperature	80°C (176°F)			
	Discharge performance III	Discharge	200 ℓ (52.8 US gal, 44.0 Imp gal) /min.			
		Pump speed — total water head	6,000 rpm — 23.0 mAq (75.5 ft Aq)			
		Water temperature	80°C (176°F)			
Impeller diameter	76 mm (2.99 in)					
Number of impeller vanes	8					
Pump pulley diameter	60 mm (2.36 in)					
Thermostat	Type	Wax pellet type				
	Starts to open	76 — 80°C (169 — 176°F)				
	Fully opens	91°C (196°F)				
	Valve lift	9.0 mm (0.354 in) or more				
*Radiator fan switch	Operation temperature	Turn ON	90 — 94°C (194 — 201°F)		—	
		Turn OFF	85 — 89°C (185 — 192°F)		—	
Electric fan	Motor	120 W				140 W
	Fan dia.	340 mm (13.39 in)				
Radiator	Type	Cross flow, pressure type				
	Core dimensions	670 x 361 x 16 mm (26.38 x 14.21 x 0.63 in)				670 x 394 x 25 mm (26.38 x 15.51 x 0.98 in)
	Pressure range in which cap valve is open	Above 88±10 kPa (0.9±0.1 kg/cm ² , 13±1.4 psi) Below — 4.9 to — 9.8 kPa (— 0.05 to — 0.1 kg/cm ² , — 0.7 to — 1.4 psi)				
Fins	Corrugated fin type					
Reserve tank	Capacity	0.6 ℓ (0.6 US qt, 0.5 Imp qt)				

*: Carburetor model only

B: SERVICE DATA

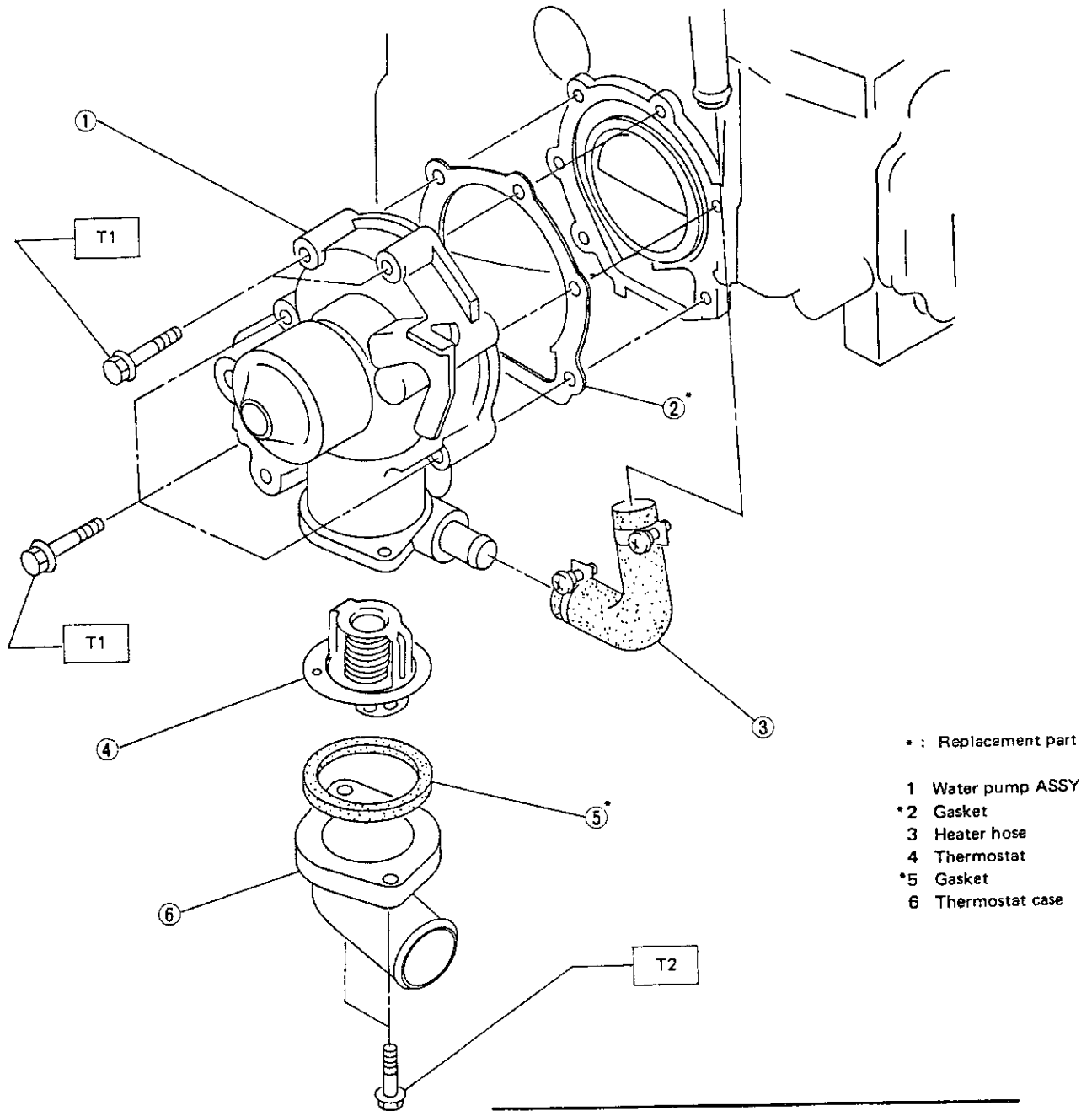
Unit: mm (in)

Water pump	Clearance between impeller and case	Standard	0.5 — 0.7 (0.020 — 0.028)
		Limit	1.0 (0.039)
	"Thrust" runout of impeller end		0.5 (0.020)

C COMPONENT PARTS

1. Water Pump

1. Non-TURBO MODEL



- : Replacement part
- 1 Water pump ASSY
- *2 Gasket
- 3 Heater hose
- 4 Thermostat
- *5 Gasket
- 6 Thermostat case

Tightening torque: N·m (kg-m, ft-lb)	
T1: First	10 — 14 (1.0 — 1.4, 7 — 10)
Second	10 — 14 (1.0 — 1.4, 7 — 10)
T2:	6 — 7 (0.6 — 0.7, 4.3 — 5.1)

Fig. 7

2. TURBO MODEL

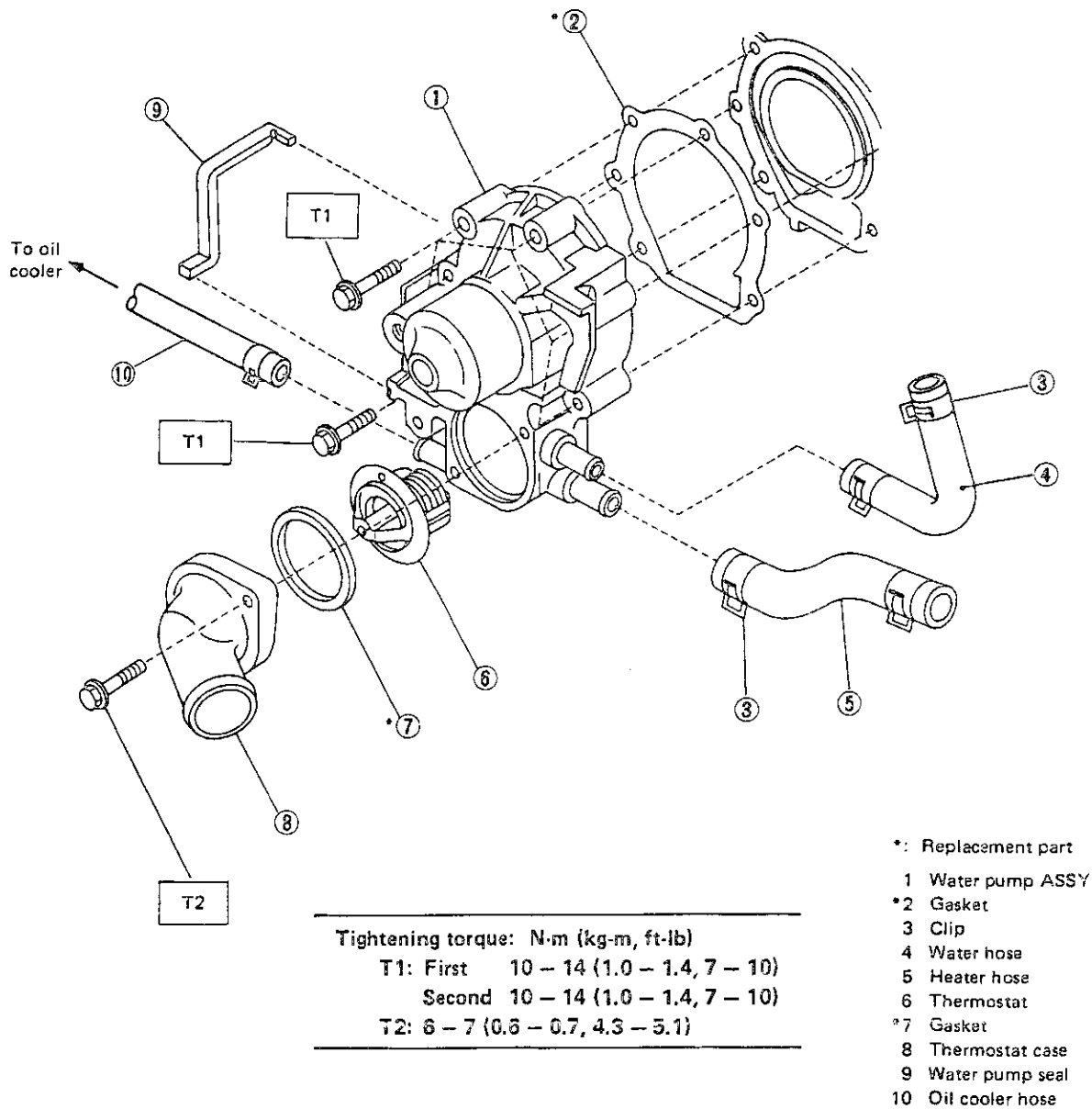


Fig. 8

B2-1099

2. Radiator and Radiator Fan

1. Non-TURBO MODEL

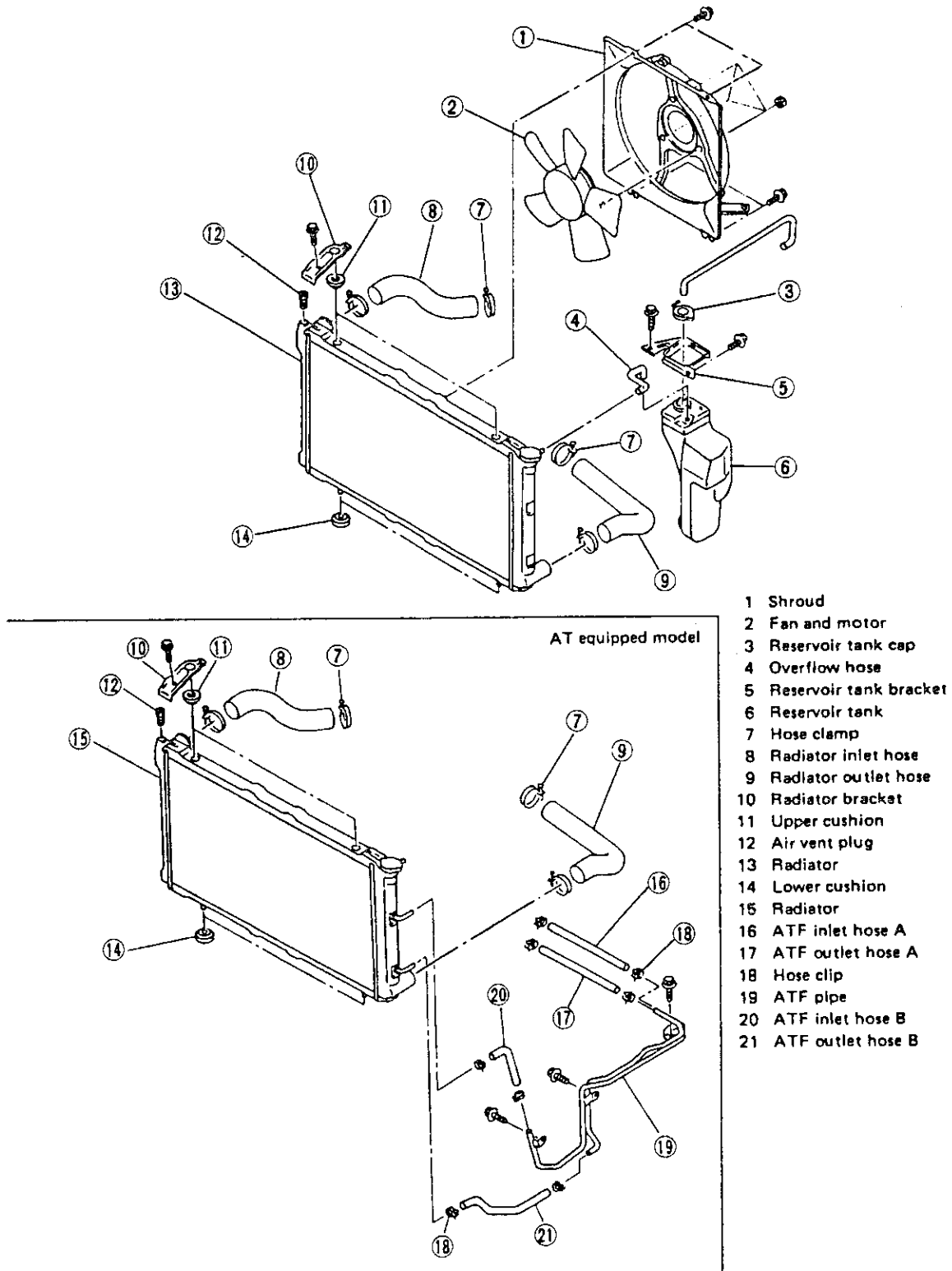
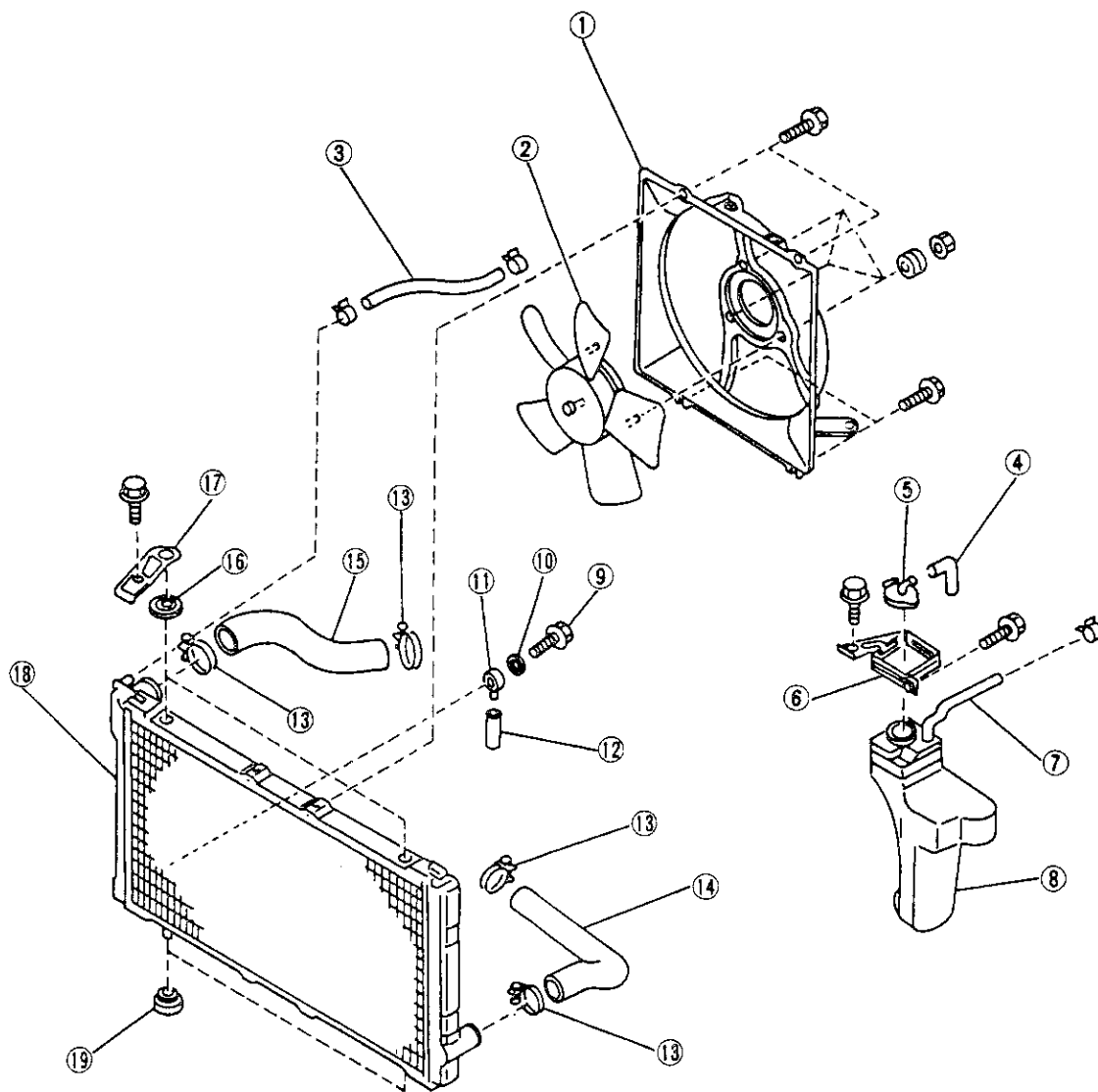


Fig. 9

2. TURBO MODEL



- | | |
|-------------------------------|-------------------------|
| 1 Shroud | 11 Drain guide |
| 2 Radiator main fan ASSY | 12 Drain tube |
| 3 Water hose (to filler tank) | 13 Hose clamp |
| 4 Overflow hose A | 14 Radiator outlet hose |
| 5 Reservoir tank cap | 15 Radiator inlet hose |
| 6 Reservoir tank bracket | 16 Upper cushion |
| 7 Overflow hose B | 17 Radiator bracket |
| 8 Reservoir tank | 18 Radiator |
| 9 Drain cock | 19 Lower cushion |
| 10 Packing | |

Fig. 10

B2-1100

W SERVICE PROCEDURE

1. Water Pump

A: REMOVAL

- 1) Open the front hood.
- 2) Disconnect the ground cable from the battery.
- 3) Drain the coolant completely.
- 4) Disconnect the radiator outlet hose.

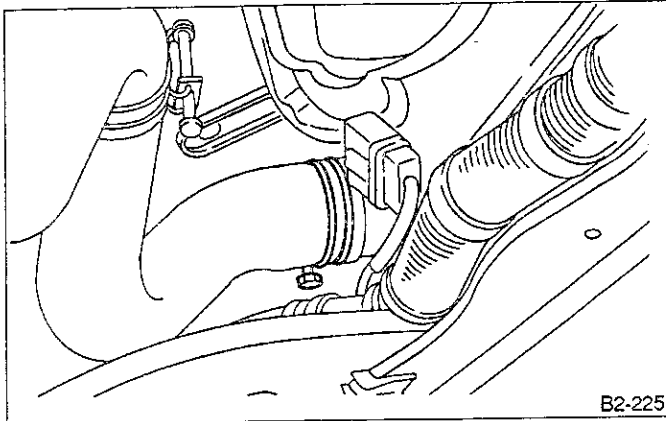


Fig. 11

- 5) Remove radiator fan motor ASSY.

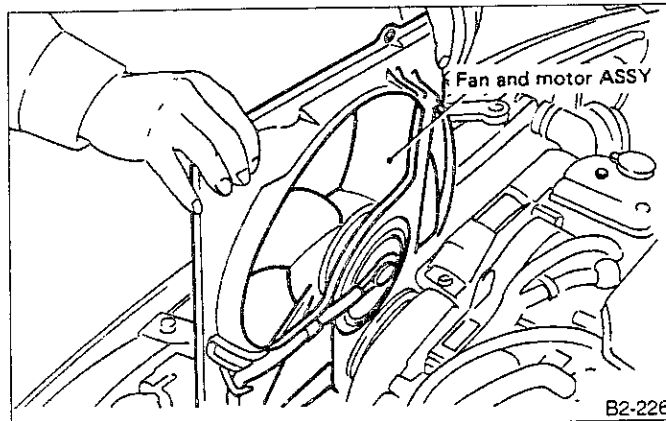


Fig. 12

- 6) Remove V-belt(s).
(Refer to "Chapter 1-5 section 1".)
- 7) Remove timing belt.
(Refer to "Chapter 1-5 section 2".)
- 8) Remove tensioner adjuster.
- 9) Remove cam angle sensor.

- 10) Remove left side camshaft pulley.

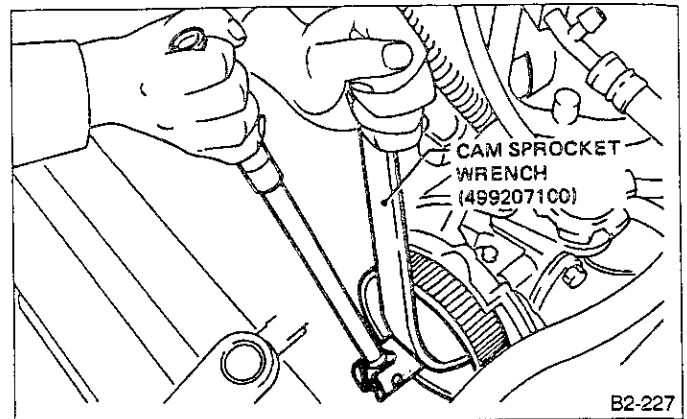


Fig. 13

- 11) Remove left side rear timing belt cover.

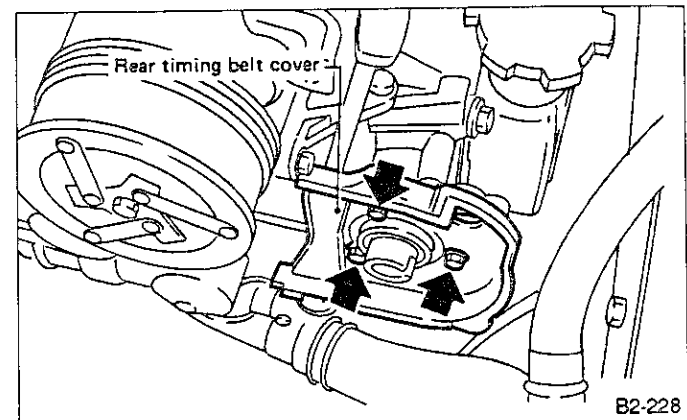


Fig. 14

- 12) Remove tensioner bracket.
- 13) Disconnect radiator hose and heater hose from water pump.
- 14) Disconnect oil cooler hose from water pump.
(Turbo model)
- 15) Remove water pump.

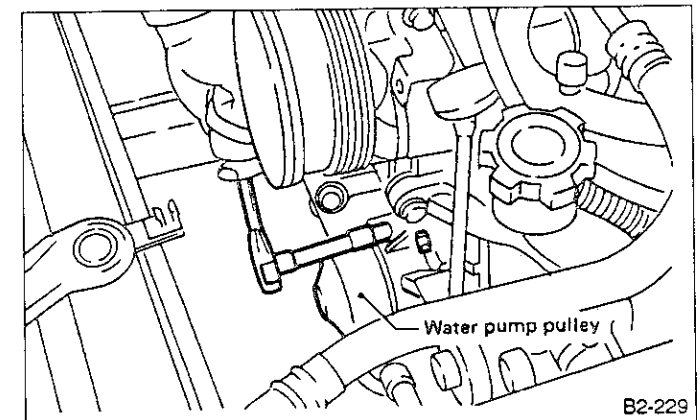


Fig. 15

B: INSPECTION

- 1) Check water pump bearing for smooth rotation.
- 2) Check water pump pulley for abnormalities.
- 3) Using a dial gauge, measure impeller runout in thrust direction while rotating the pulley.

"Thrust" runout limit:
0.5 mm (0.020 in)

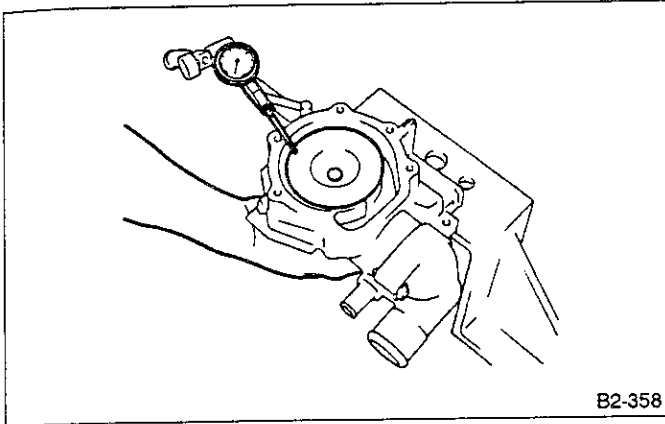


Fig. 16

- 4) Check clearance between impeller and pump case.

Clearance between impeller and pump case:
Standard
0.5 — 0.7 mm (0.020 — 0.028 in)
Limit
1.0 mm (0.039 in)

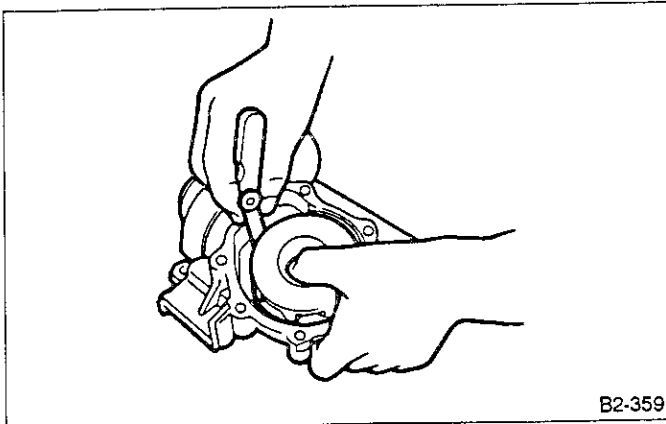


Fig. 17

- 5) After water pump installation, check pulley shaft for water leaks. If leaks are noted, replace water pump ASSY.

C: INSTALLATION

Installation is in the reverse order of removal.

- a. Always use a new gasket.
- b. When installing water pump, tighten all bolts in two steps in numerical sequence as shown in Figure.

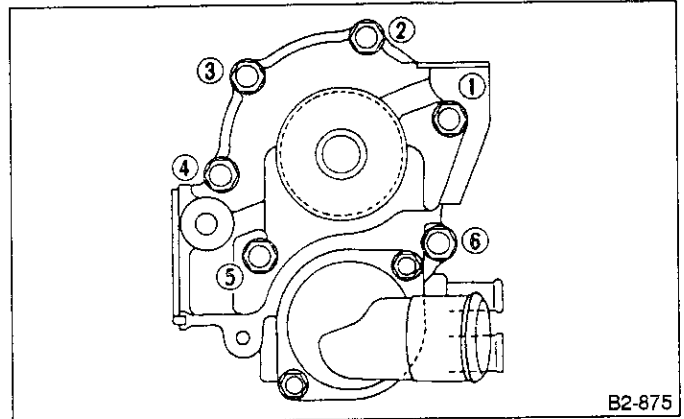


Fig. 18

Tightening torque: N·m (kg-m, ft-lb)
First: 10 — 14 (1.0 — 1.4, 7 — 10)
Second: 10 — 14 (1.0 — 1.4, 7 — 10)

- c. After reinstalling the water pump, run the engine to make sure that neither water leakage nor abnormal noise exists.

2. Thermostat

A: REMOVAL AND INSTALLATION

- 1) Remove the thermostat case cover and gasket, and pull out the thermostat.
- 2) Install the thermostat in the intake manifold, and install the thermostat cover together with a gasket.
 - a. When reinstalling the thermostat, use a new gasket.
 - b. The thermostat must be installed with the jiggle pin upward.
 - c. In this time, set the jiggle pin of thermostat for front side.

B: INSPECTION

Replace the thermostat if the valve does not close completely at an ambient temperature or if the following test shows unsatisfactory results. Immerse the thermostat and a thermometer in water. Raise water temperature gradually, and measure the temperature and valve lift when the valve begins to open and when the valve is fully opened. During the test, agitate the water for even temperature distribution. The measurement should be to the specification.

Starts to open:

76.0 — 80.0°C (169 — 176°F)

Fully opens:

91°C (196°F)

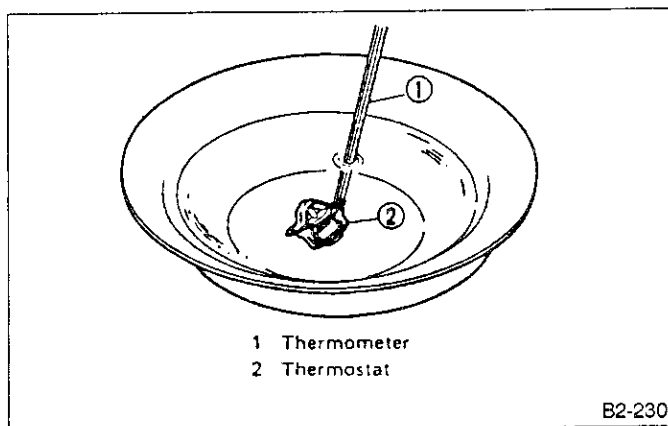


Fig. 19

3. Radiator

A: ON CAR SERVICE

- 1) Remove radiator cap, top off radiator, and attach tester to radiator in place of cap.

On turbo model, check at coolant filler tank cap.
- 2) Apply a pressure of 157 kPa (1.6 kg/cm², 23 psi) to radiator to check if:
 - (1) Water leaks at/around radiator.
 - (2) Water leaks at/around hoses or connections.

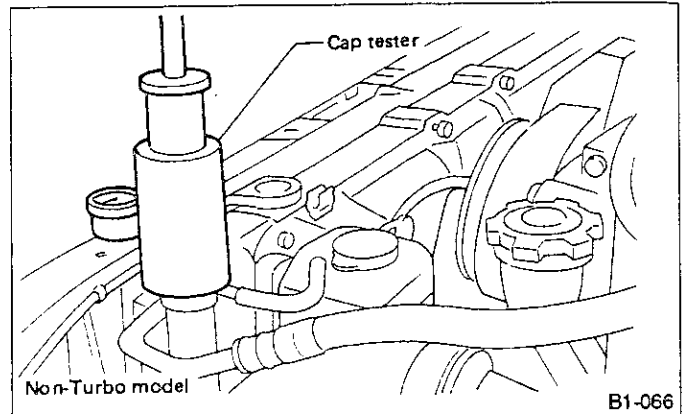


Fig. 20

- a. Engine should be off.
- b. Wipe water from check points in advance.
- c. Be careful to prevent cooling water from spurting out when removing tester.
- d. Be careful also not to deform filler neck of radiator when installing or removing tester.

B: REMOVAL

- 1) Disconnect battery cables and remove battery from body.
- 2) Drain coolant.
- 3) Disconnect inlet and outlet hoses from water pipe.

Drain coolant into container.
- 4) Remove V-belt cover.

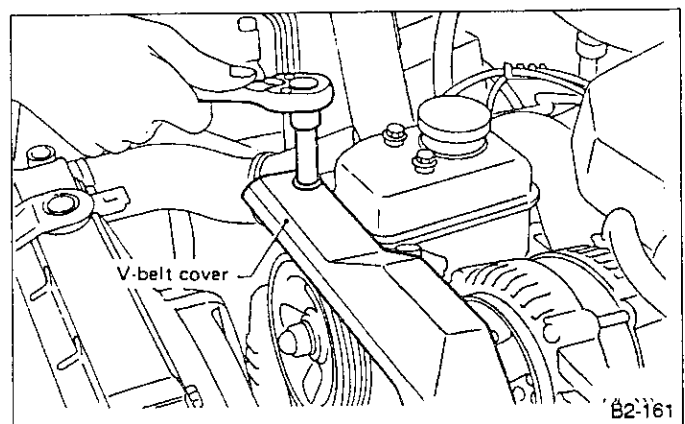


Fig. 21

- 5) Remove reservoir tank and over-flow hose. (Non-Turbo model)
- 6) Disconnect coolant filler tank hose from radiator. (Turbo model)
- 7) Disconnect connectors of radiator main fan and sub fan motor.
- 8) Remove radiator brackets.

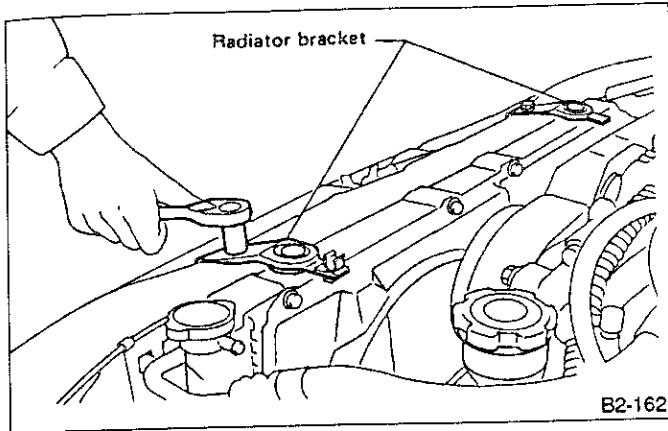


Fig. 22

- 9) While slightly lifting radiator, slide it to left.
- 10) Disconnect ATF cooler hoses from radiator. (AT model)

Drain ATF into container.

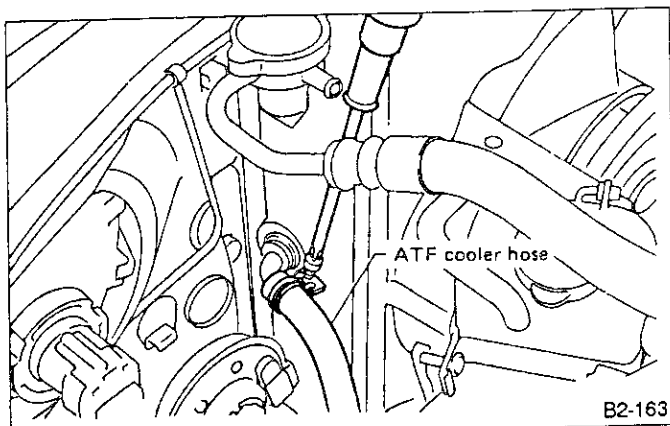


Fig. 23

- 11) Lift radiator up and away from vehicle.

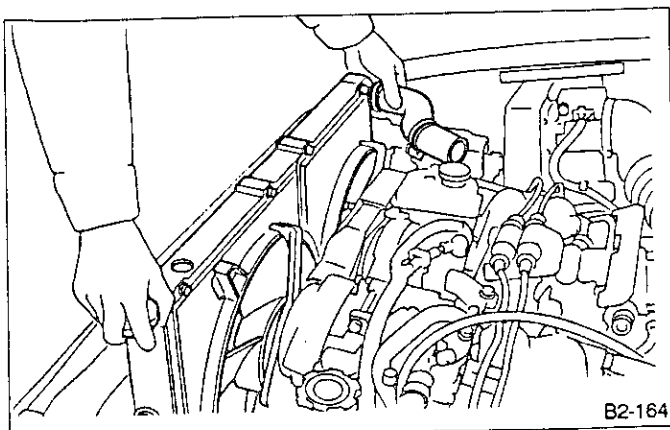


Fig. 24

C: INSTALLATION

- 1) Attach radiator mounting cushions to pins on the lower side of radiator.

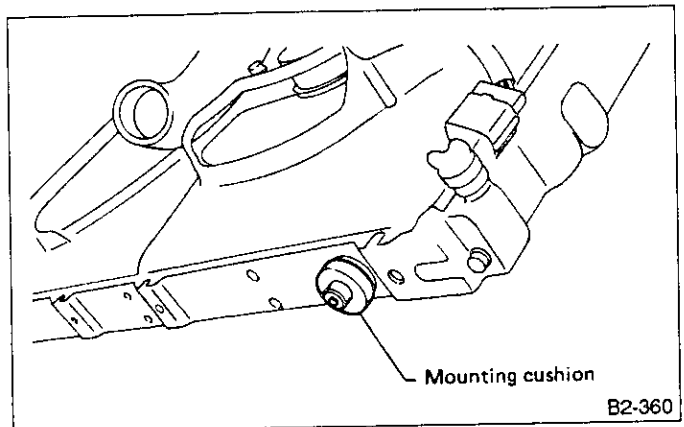


Fig. 25

- 2) Fit cushions, on lower side of radiator, into holes on body side and install radiator.

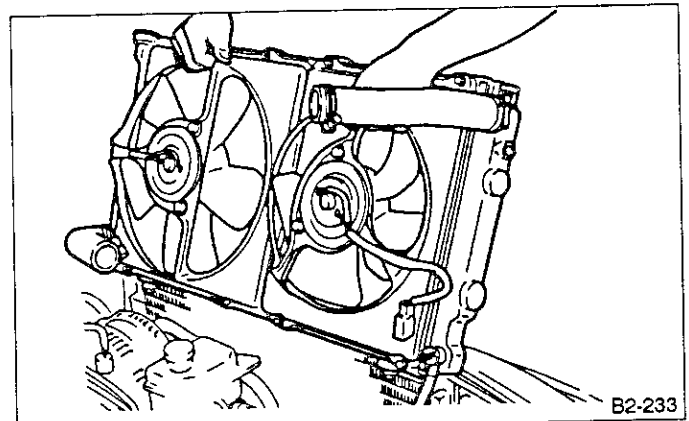


Fig. 26

- 3) Install radiator brackets and tighten bolts.
- 4) Connect radiator main fan motor and sub fan motor connectors.
- 5) Connect radiator hoses (inlet and outlet).
- 6) Install reservoir tank and over-flow hose.
- 7) Install V-belt.
- 8) Connect ground cable to battery terminal.
- 9) Fill coolant.

- (1) Remove air vent plug on radiator. (Non-Turbo model only)
- (2) Fill coolant into radiator up to filler neck position.

On turbo models, always pour coolant into coolant filler tank.

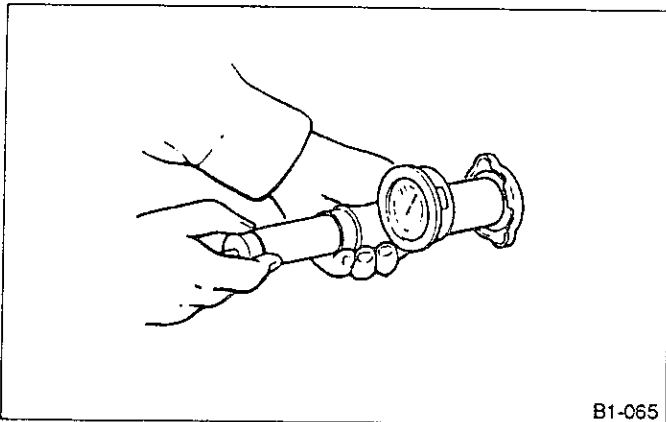
- (3) Fill coolant into reservoir tank up to upper level.
- (4) Attach radiator cap, air vent plug and reservoir tank cap properly.
- (5) Warm up engine completely. (For more than 5 minutes at 2,000 to 3,000 rpm.)

- (6) Stop engine and wait until temperature drops to a safe level.
- (7) Remove air vent plug and radiator cap.
- (8) If coolant level drops in radiator, add coolant to filler neck position.
- (9) If coolant level drops from upper level of reservoir tank, add coolant to upper level.
- (10) Attach radiator cap, air vent plug and reservoir tank cap properly.

4. Radiator Cap (Filler Tank Cap on Turbo Model)

A: INSPECTION

- 1) Attach radiator cap to tester.
- 2) Increase pressure until tester gauge pointer stops. Radiator cap is functioning properly if it holds the service limit pressure for five to six seconds.



B1-065

Fig. 27

Standard pressure:

78 — 98 kPa (0.8 — 1.0 kg/cm², 11 — 14 psi)

Service limit pressure:

69 kPa (0.7 kg/cm², 10 psi)

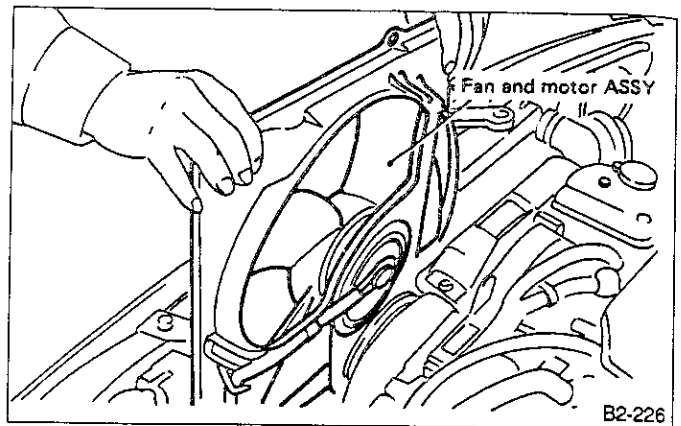
Be sure to remove foreign matter and rust from the cap in advance; otherwise, results of pressure test will be incorrect.

5. Radiator Fan and Fan Motor

A: REMOVAL

- 1) Disconnect ground cable from battery terminal.
- 2) Disconnect connector from fan motor.
- 3) Remove reservoir tank.
- 4) Loosen two bolts holding shroud to radiator underside.
- 5) Remove two bolts holding shroud to radiator upper side.

- 6) Remove radiator fan motor ASSY.



B2-226

Fig. 28

- 7) Remove fan motor ASSY from shroud.

B: INSTALLATION

Installation is in the reverse order of removal procedures.

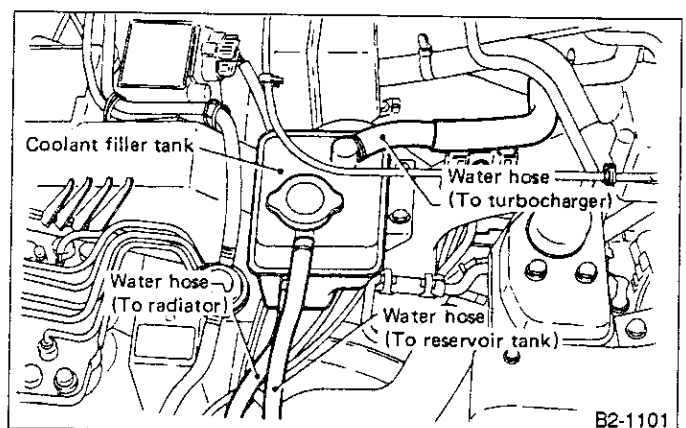
Observe the following:

- 1) Before installing radiator fan motor, apply a coat of sealant to threads and tighten nuts.
- 2) Make sure radiator fan does not come into contact with shroud when installed.
- 3) After installation, make sure there is no unusual noise or vibration when fan is rotated.

6. Coolant Filler Tank

A: REMOVAL

- 1) Remove hoses from coolant filler tank.
- 2) Remove the two bolts, and remove coolant filler tank.



B2-1101

Fig. 29

B: INSTALLATION

Installation is in the reverse order of removal procedures.

T TROUBLESHOOTING

Trouble	Possible cause	Corrective action
Over-heating	a. Insufficient coolant.	Replenish coolant, inspect for leakage, and repair.
	b. Loose timing belt.	Repair or replace timing belt tensioner.
	c. Oil on timing belt.	Replace.
	d. Malfunction of thermostat.	Replace.
	e. Malfunction of water pump.	Replace.
	f. Clogged coolant passage.	Clean.
	g. Improper ignition timing.	Adjust.
	h. Clogged or leaking radiator.	Clean or repair, or replace.
	i. Improper engine oil.	Replace.
	j. Air-fuel mixture too thin.	Inspect and repair fuel system.
	k. Excessive back pressure in exhaust system.	Clean or replace.
	l. Insufficient clearance between piston and cylinder.	Adjust or replace.
	m. Slipping clutch.	Repair or replace.
	n. Dragging brake.	Adjust.
	o. Improper transmission oil.	Replace.
p. Defective thermostat.	Replace.	
q. Malfunction of electric fan.	Inspect radiator fan relay, water temperature sensor or motor, and replace there.	
Over-cooling	a. Atmospheric temperature extremely low.	Partly cover radiator front area.
	b. Defective thermostat.	Replace.
Coolant leaks	a. Loosened or damaged connecting units on hoses.	Repair or replace.
	b. Leakage from water pump.	Replace.
	c. Leakage from intake manifold.	Repair or replace.
	d. Leakage around cylinder head gasket.	Retighten cylinder head nuts or replace gasket.
	e. Damaged or cracked cylinder head and crankcase.	Repair or replace.
	f. Damaged or cracked thermostat case.	Repair or replace.
	g. Leakage from radiator.	Repair or replace.
Noise	a. Defective timing belt.	Replace.
	b. Defective radiator fan.	Replace.
	c. Defective water pump bearing.	Replace water pump.
	d. Defective water pump mechanical seal.	Replace water pump.

SUBARU®

1992

**SERVICE
MANUAL**

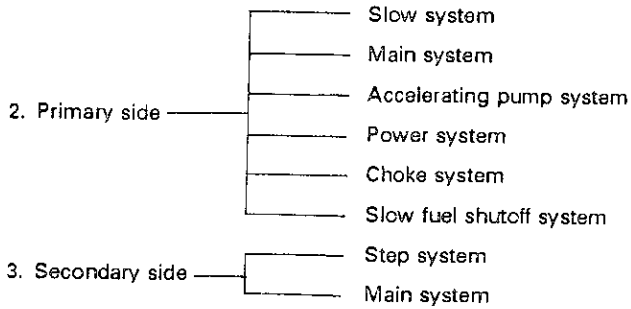


	Page
M MECHANISM AND FUNCTION	2
1. Float System	2
SWITCH VENT SOLENOID VALVE	2
2. Primary Side	3
SLOW SYSTEM	3
MAIN SYSTEM	4
ACCELERATING PUMP SYSTEM	5
POWER SYSTEM	6
SLOW FUEL SHUTOFF SYSTEM	7
3. Secondary Side	7
STEP SYSTEM	7
MAIN SYSTEM	8
4. Fuel Supplement System When Cornering	9
5. Automatic Choke System	10
AUTOMATIC CHOKE MECHANISM	10
VACUUM DIAPHRAGM MECHANISM	11
CHOKE BREAK DELAY VALVE MECHANISM	12
S SPECIFICATIONS AND SERVICE DATA	13
SPECIFICATIONS	13
MAINTENANCE STANDARDS	14
C COMPONENT PARTS	15
1. Air Intake System and Air Cleaner	15
2. Intake Manifold and Carburetor	16
3. Carburetor ASSY	17
W SERVICE PROCEDURE	18
REMOVAL	18
DISASSEMBLY	18
INSPECTION	19
ASSEMBLY	20
INSTALLATION	22
REPLACEMENT	22
CHECK AND ADJUSTMENT	23
T TROUBLESHOOTING	29

M MECHANISM AND FUNCTION

The carburetor is a two-barrel, down-draft type and consists essentially of the following systems.

1. Float system



4. Fuel supplement system when cornering

5. Automatic choke system

1. Float System

The primary and secondary sides share the same float system. The fuel in the fuel tank is routed through the fuel pump and needle valve into the float chamber. The

fuel level in the float chamber is always maintained constant by the functions of the needle valve and float. The height of the fuel level is adjustable by adjusting the float seat.

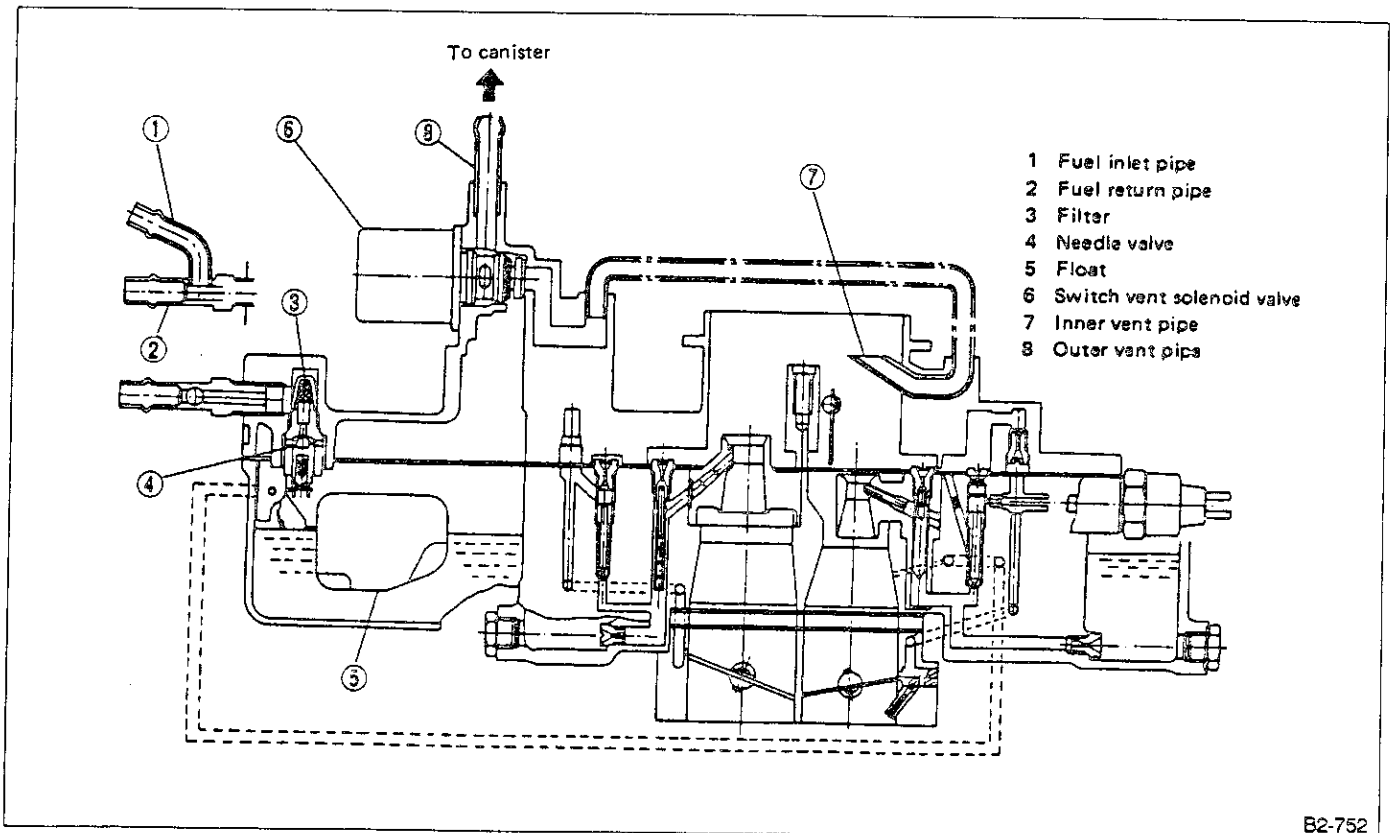
A: SWITCH VENT SOLENOID VALVE

The switch vent solenoid valve goes off when the engine stops (with ignition key in the "OFF" position) and the valve seat is pushed by the spring tension and blocks the inner vent.

This directs the pressure inside the float chamber and the evaporative gas toward the canister through the outer vent pipe.

When the engine is started (with the ignition key in the "ON" position), the solenoid valve comes on and the magnetic force overcomes the spring tension.

By this, the outer vent is blocked and the inner vent functions normally.



- 1 Fuel inlet pipe
- 2 Fuel return pipe
- 3 Filter
- 4 Needle valve
- 5 Float
- 6 Switch vent solenoid valve
- 7 Inner vent pipe
- 8 Outer vent pipe

Fig. 1

B2-752

2. Primary Side

A: SLOW SYSTEM

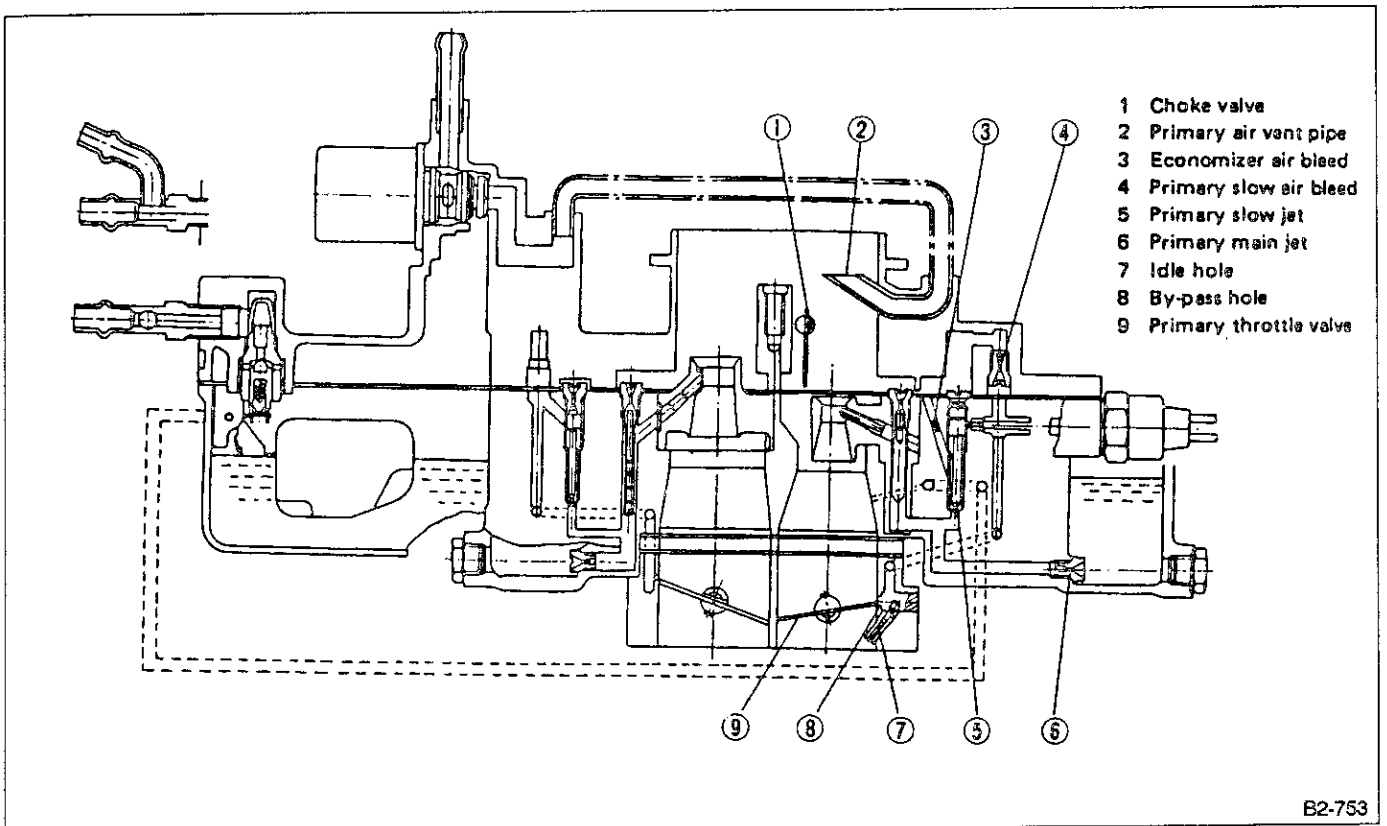
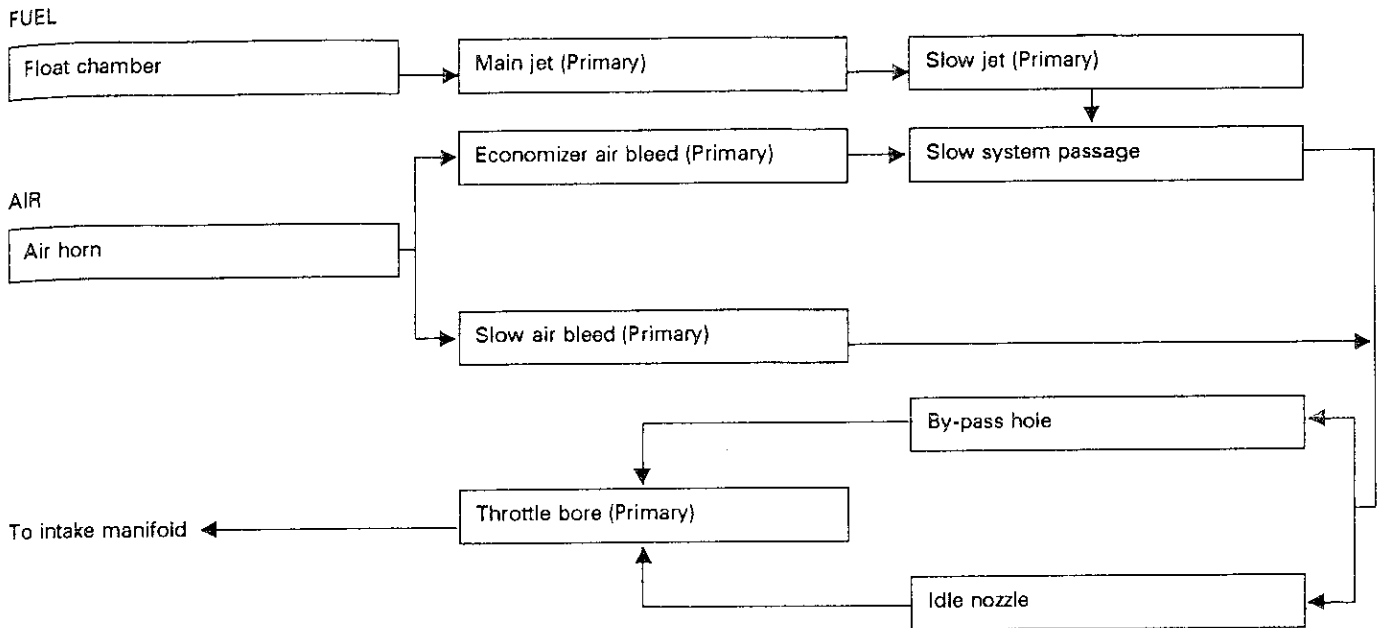
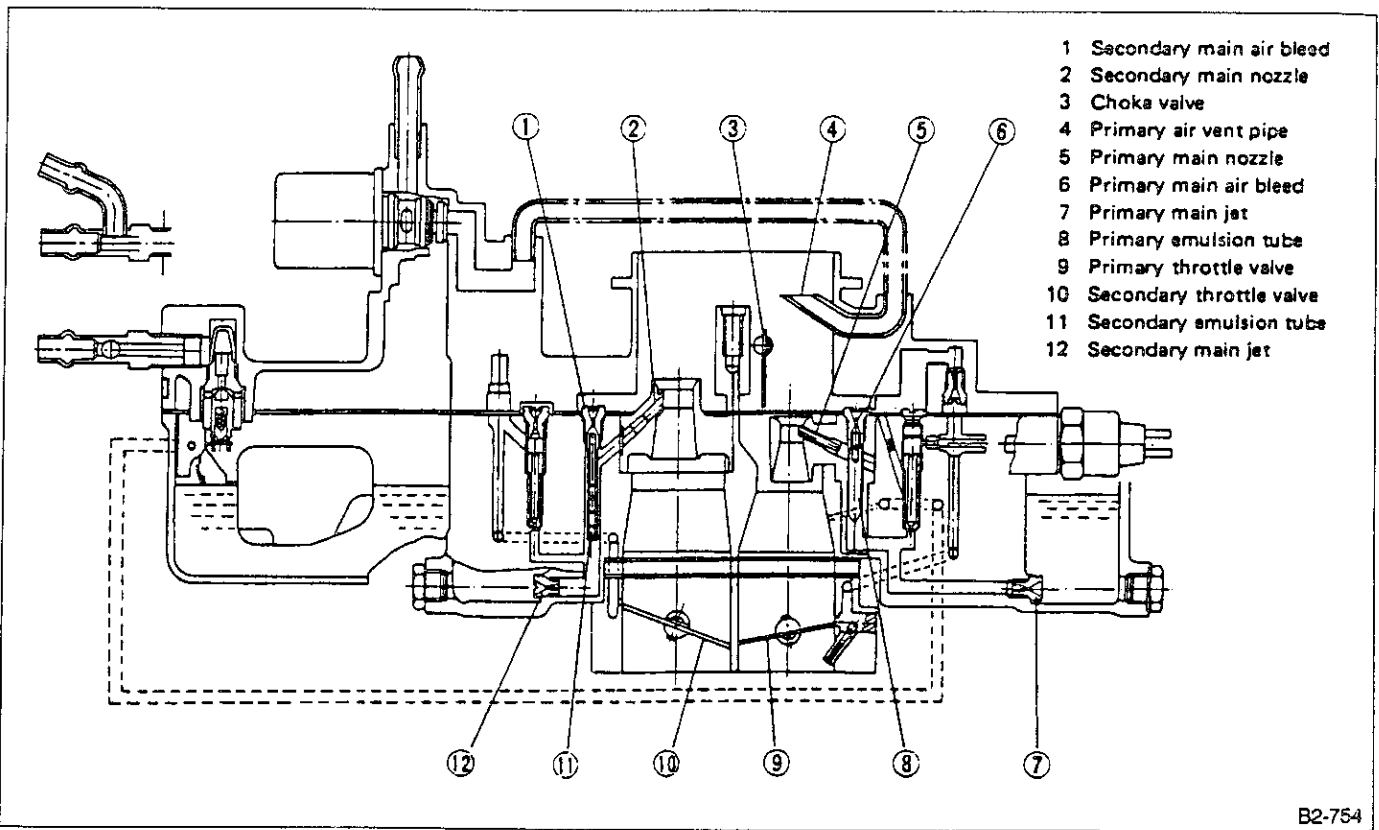
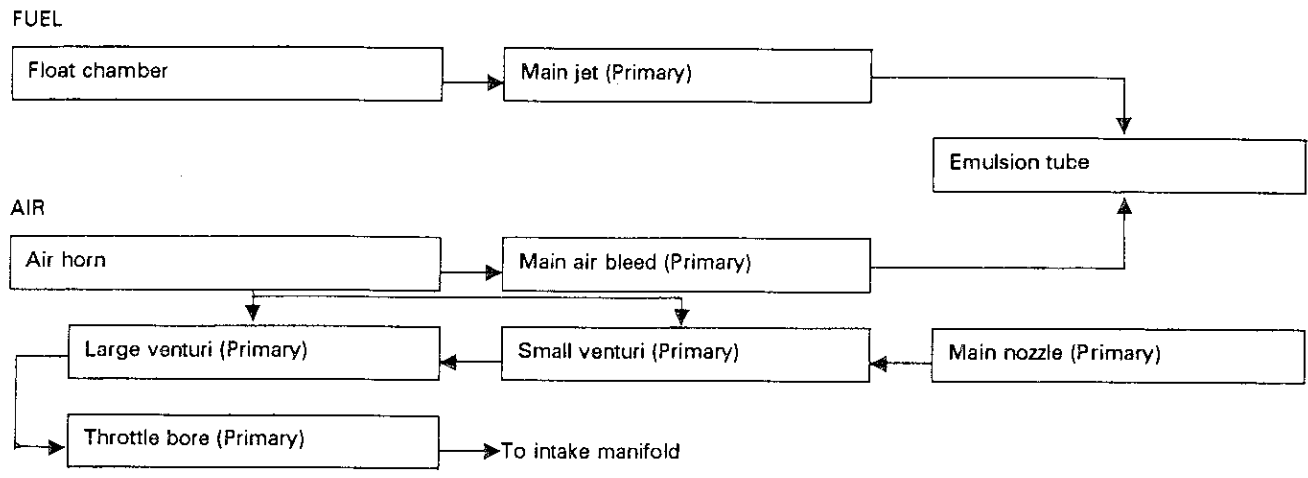


Fig. 2

B: MAIN SYSTEM



B2-754

Fig. 3

C: ACCELERATING PUMP SYSTEM

FUEL

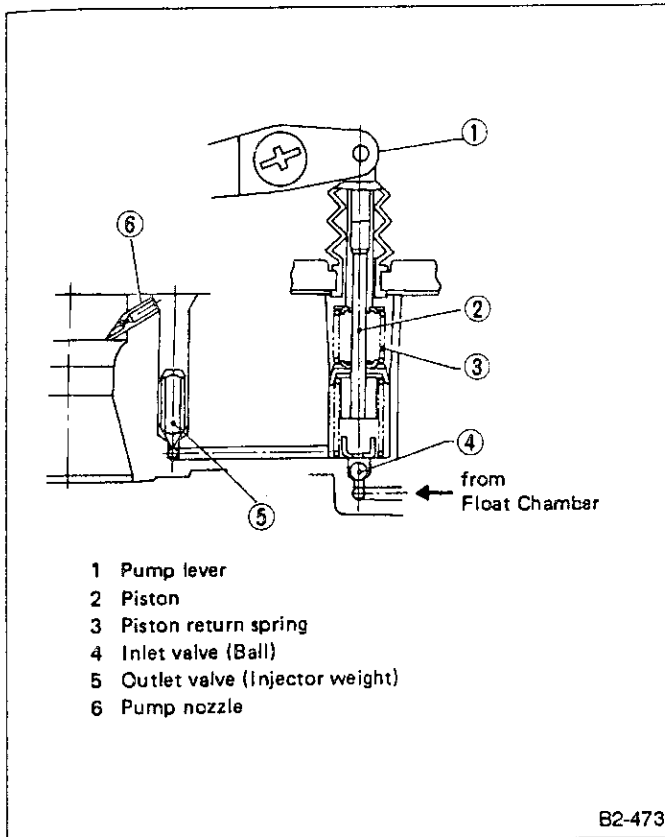
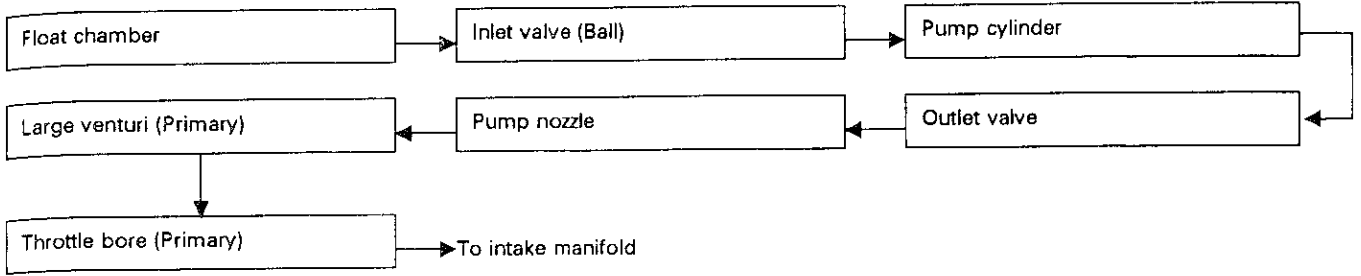


Fig. 4

D: POWER SYSTEM

FUEL

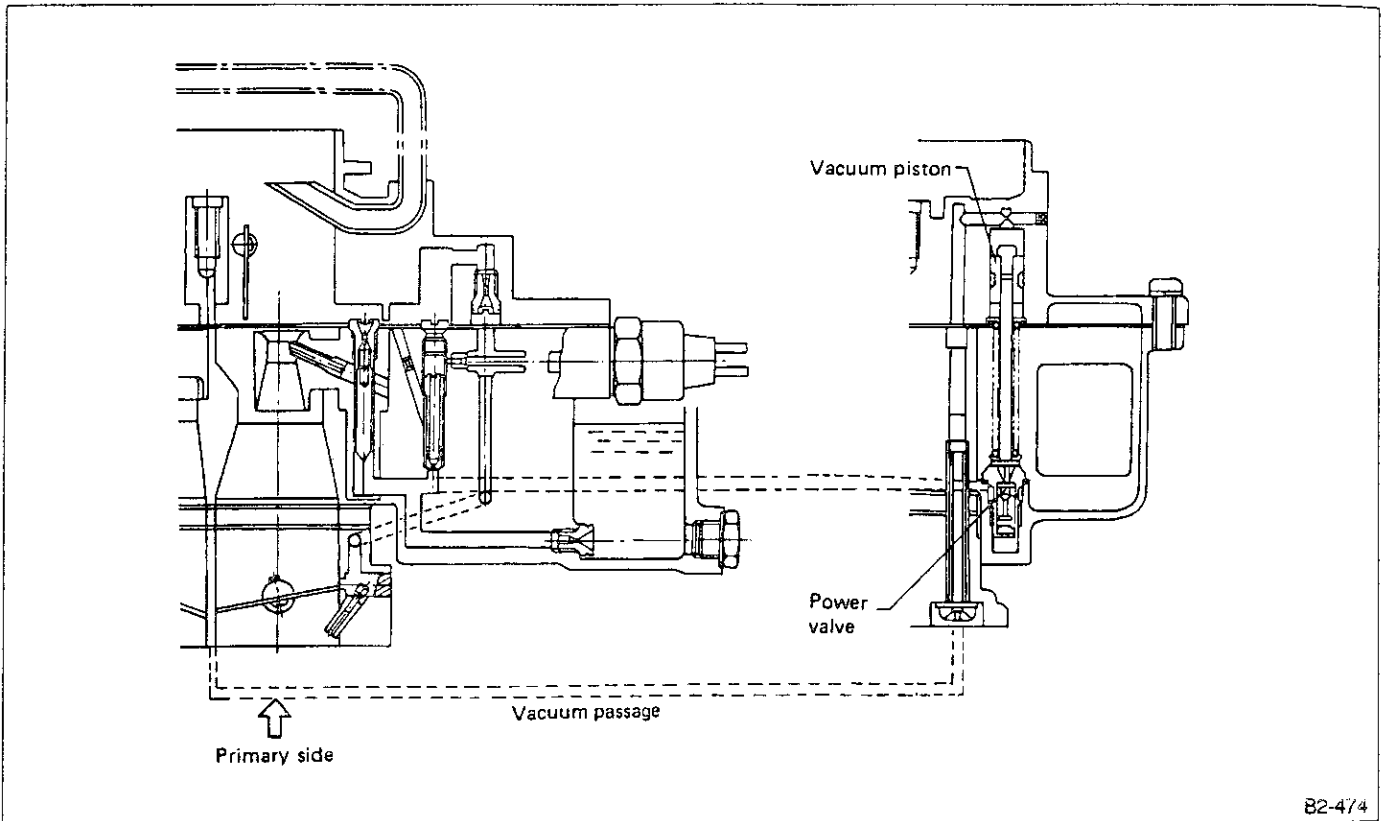
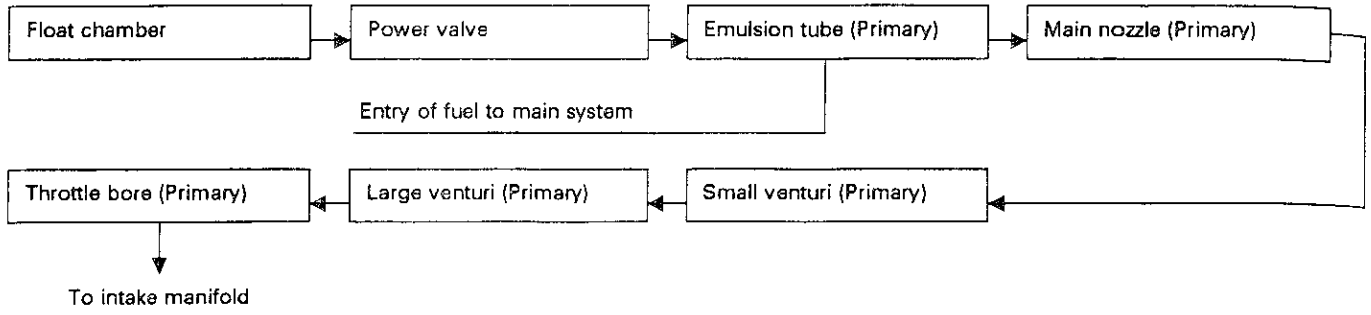
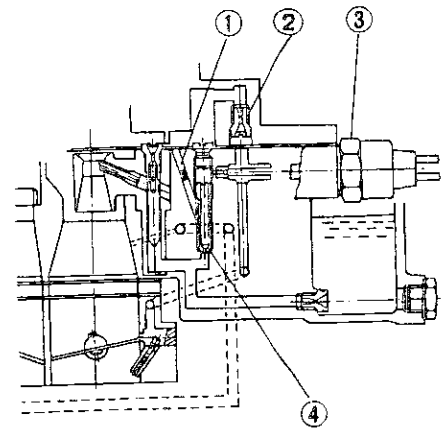


Fig. 5

E: SLOW FUEL SHUTOFF SYSTEM

When the ignition starter switch is in the position other than "ON" or "START", current does not flow to the anti-dieseling switch and the anti-dieseling switch needle valve cuts off fuel feed passage, thus preventing the engine from dieseling.



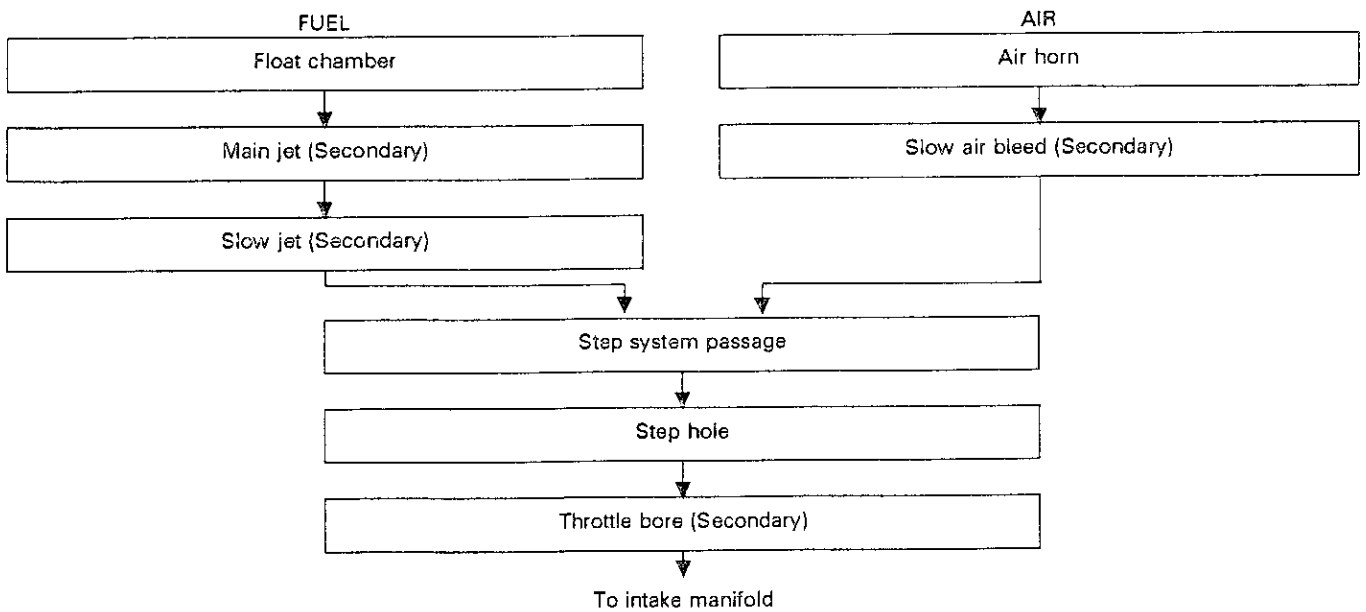
- 1 Economizer air bleed
- 2 Primary slow air bleed
- 3 Anti-dieseling switch
- 4 Primary slow jet

B2-475

Fig. 6

3. Secondary Side

A: STEP SYSTEM



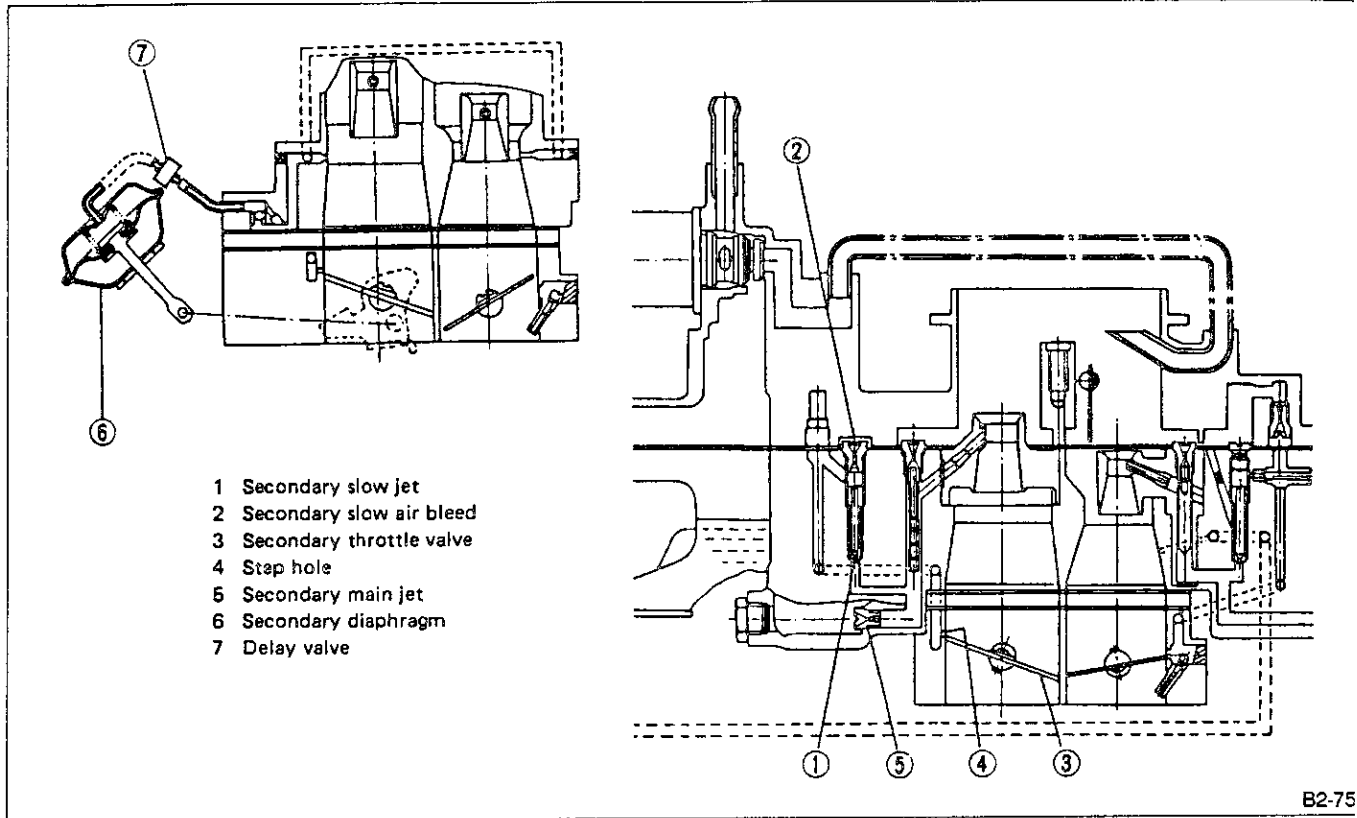
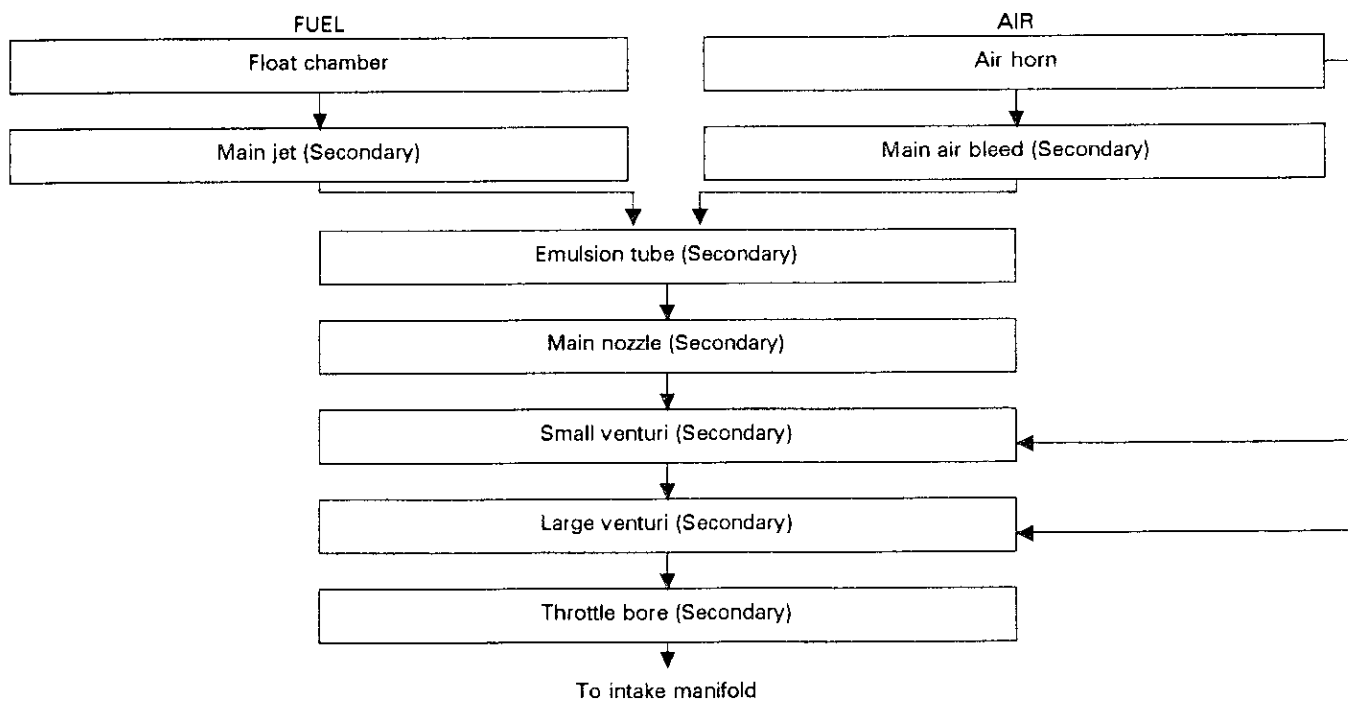


Fig. 7

B: MAIN SYSTEM



For the construction, refer to "Main System" in the Primary Side section.

4. Fuel Supplement System When Cornering

When the car makes a right turn, the fuel level within the float chamber is tilted. This causes the fuel to flow through the fuel supplement passage to the nozzle. From the nozzle, the fuel is directed to the downstream side of the large venturi to improve driving performance around corners.

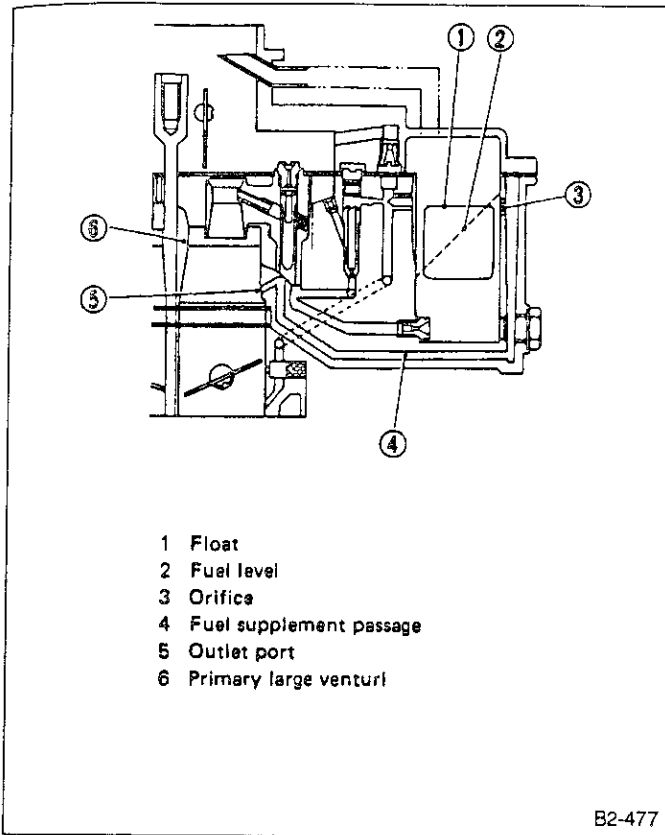


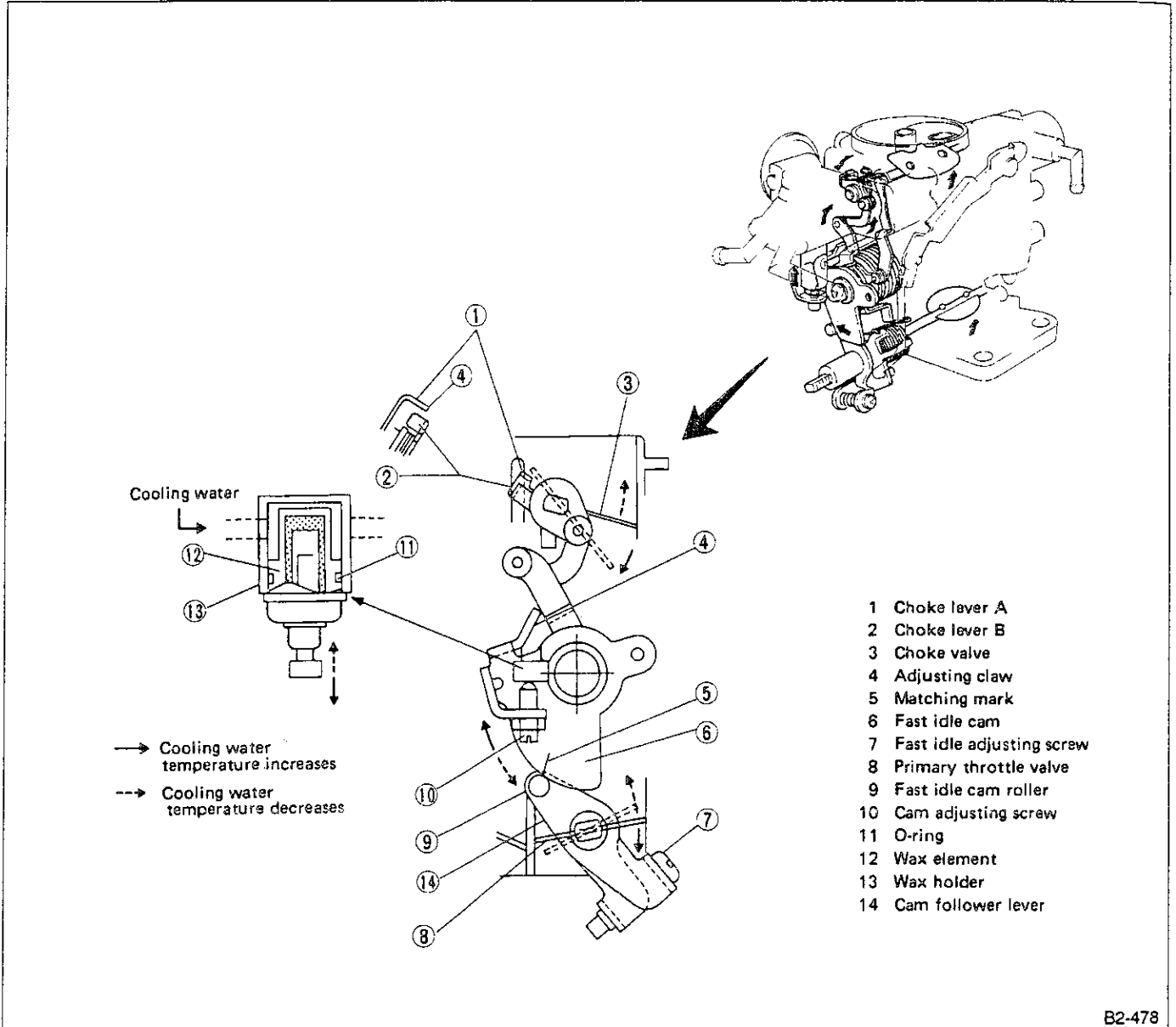
Fig. 8

5. Automatic Choke System

A: AUTOMATIC CHOKE MECHANISM

This automatic choke is the system that automatically adjusts choke valve and throttle valve openings in accordance with change in coolant temperature. Automatic choke system consists of wax element, fast idle cam, fast idle lever, and main vacuum diaphragm.

1. LINK MECHANISM



B2-478

Fig. 9

(Engine start with low coolant temperature)

When coolant temperature is low, wax element is in the compressed position. As first idle cam compresses wax element rod by the force of return spring, connecting lever is raised and choke valve closes fully. The best throttle valve opening can be obtained by the fast idle lever roller set on the crest of the fast idle cam.

(Choke release)

As wax element expands and rod extends when engine warms up, fast idle cam rotates and choke valve opens fully. As fast idle cam rotates, fast idle lever comes off fast idle cam and throttle valve opening returns to the normal idling position. Engine warming up is thus completed.

2. Unloader mechanism

When engine is accelerated on cold start-up, unloader system opens choke valve in accordance with rotation of throttle valve to prevent fuel mixture from becoming too rich.

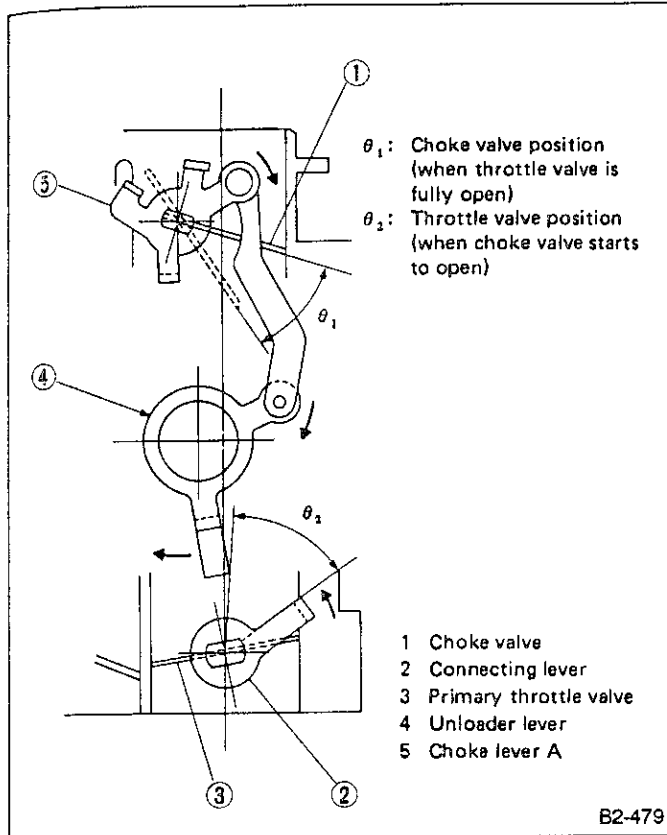


Fig. 10

Choke valve opens in response to throttle valve via links which move in directions shown by arrows.

B: VACUUM DIAPHRAGM MECHANISM

This mechanism automatically controls choke valve opening just after engine is started. To obtain the fuel mixture best suitable for wide range temperature (from extremely low to normal temperature), choke valve opening is controlled in 2 stages by manifold vacuum and choke strangler spring pressure.

1. At low temperatures

(1st stage)

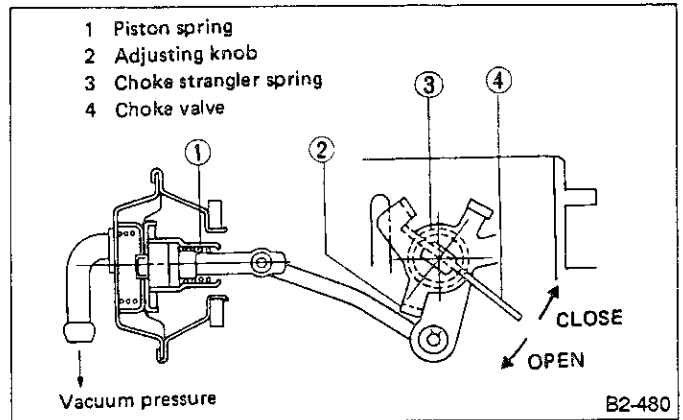


Fig. 11

When engine starts, vacuum is created in manifold and diaphragm operates, raising diaphragm rod to open the choke valve. Choke valve, however, opens slightly because of restraining force of choke strangler spring (spring that closes choke valve).

2. At normal temperatures

(2nd stage)

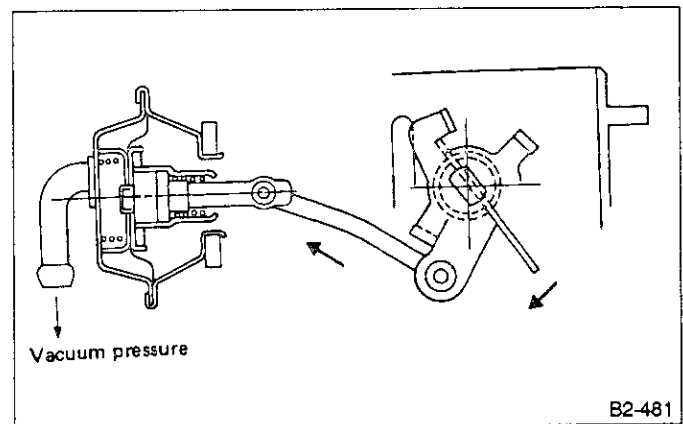


Fig. 12

When coolant temperature is close to normal temperature [15°C (59°F) to 30°C (86°F)], wax element of automatic choke system expands, rod extends, and fast idle cam rotates, reducing the choke strangler spring force (i.e. spring force that closes choke valve). As piston spring force overcomes the force of choke strangler spring at this time, choke valve opens wider.

C: CHOKE BREAK DELAY VALVE MECHANISM

The choke break delay valve mechanism momentarily delays an abrupt change in the air-fuel ratio immediately after vacuum pressure is created during starts, and provides smooth engine operation.

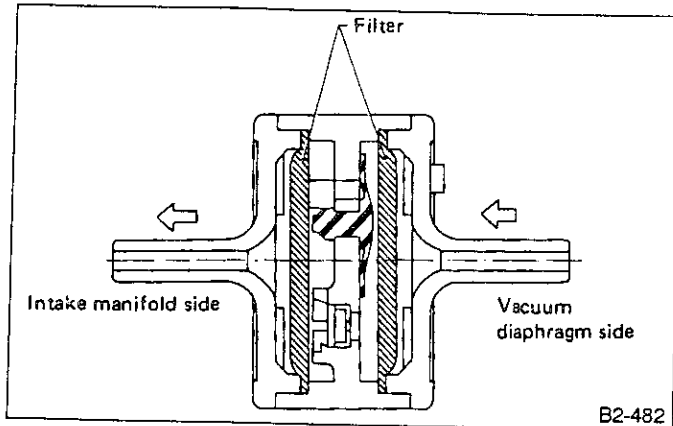


Fig. 13

S SPECIFICATIONS AND SERVICE DATA

A: SPECIFICATIONS

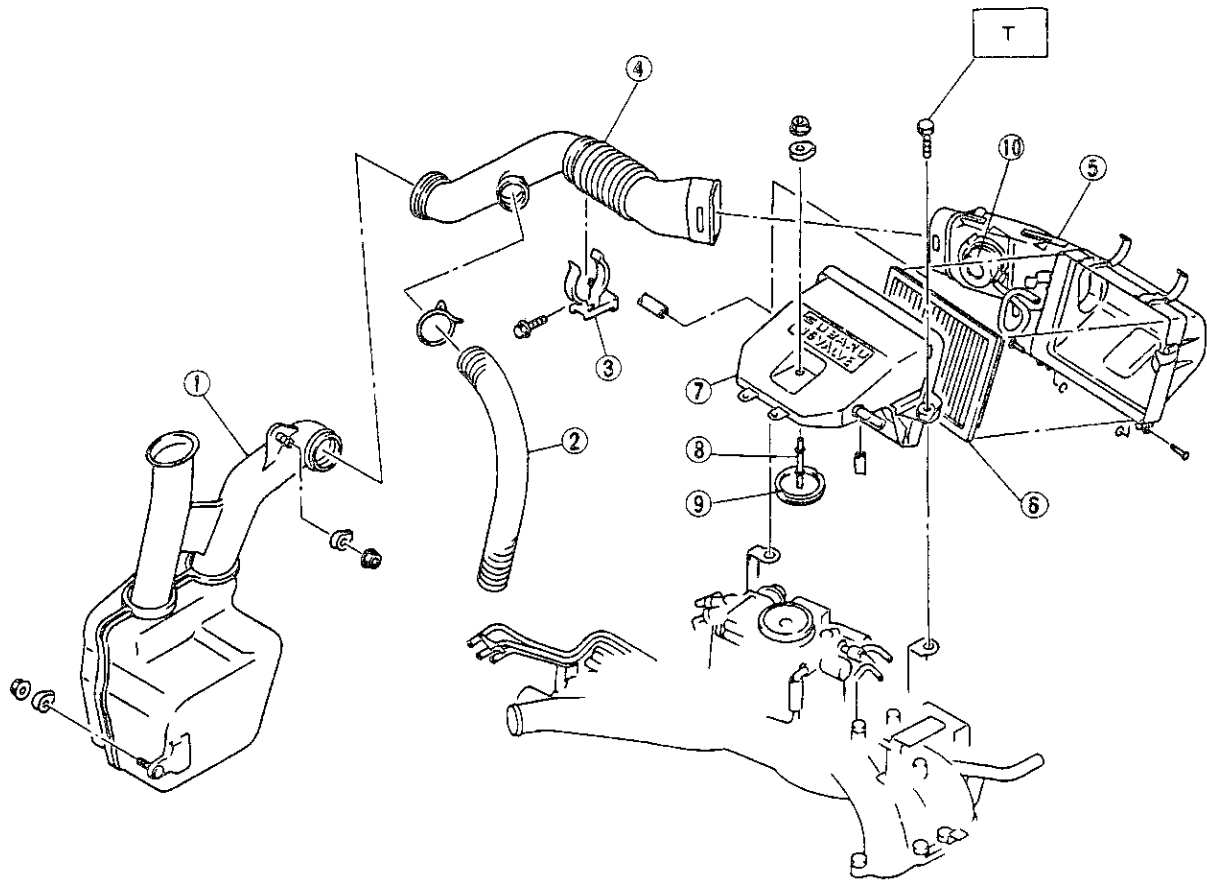
Vehicle		1600 cc, 1800 cc		1800 cc
		5MT	3AT	4AT
Carburetor		DCY340-500	DCY340-510	DCY340-521
Air horn dia. (Inner x outer)		59 x 63 mm (2.32 x 2.48 in)		
Throttle bore (P-S)		30 — 34 mm (1.18 — 1.34 in)		
Inner dia. of needle valve		1.7 mm (0.067 in)		
Main system	Large venturi dia. (P-S)	20 — 30 mm (0.79 — 1.18 in)		
	Small venturi dia. (P-S)	10/13 — 11/15 mm (0.39/0.51 — 0.43/0.59 in)		
	Main jet (P-S)	#101 — #155		
	Main air bleed (P-S)	#75 — #100		
	Main nozzle dia. (Inner x outer)	P	2.1 x 3.0 mm (0.083 x 0.118 in)	
		S	2.8 x 4.0 mm (0.110 x 0.157 in)	
	Main nozzle end surface angle	P	5°	
		S	5°	
	Emulsion tube (Inner x outer x length)	P	2.4 x 4.0 x 24.5 mm (0.094 x 0.157 x 0.965 in)	
		S	2.4 x 3.6 x 40 mm (0.094 x 0.142 x 1.57 in)	
Emulsion hole (Dia. x number of holes)	P	0.6 mm (0.024 in) x 7		
	S	1.05 mm (0.0413 in) x 4, 1.0 mm (0.039 in) x 16		
Slow system	Slow jet (P-S)	#43 — #110		
	Slow air bleed (P-S)	#160 — #0		
	Economizer bleed (P-S)	#90 — #0		
Power jet		#50		
Accelerating pump system	Accelerating pump nozzle dia.	0.4 mm (0.016 in)		
	Weight of accelerating pump injector	2 g (0.07 oz)		
Starting system	Choke system	Full automatic choke (Wax type)		
	Choke valve angle when fully closed	16°		
Primary throttle valve angle when fully closed		10.5°		

B: MAINTENANCE STANDARDS

Vehicle		1600 cc, 1800 cc		1800 cc
		5MT	3AT	4AT
Carburetor		DCY340-500	DCY340-510	DCY340-521
Fast idle opening adjustment	Fast idle opening clearance of primary throttle valve [At 25°C (77°F)]	$G_1 = 0.5 - 0.68$ mm (0.0197 - 0.0268 in)	$G_1 = 0.5 - 0.68$ mm (0.0197 - 0.0268 in)	$G_1 = 0.68 - 0.90$ mm (0.0268 - 0.0354 in)
	Fast idle opening clearance of choke valve [At 25°C (77°F)]	$R_1 = 0.70 - 0.95$ mm (0.0276 - 0.0374 in)		
Vacuum break opening adjustment	Choke valve clearance when choke opener is operating. [At 23°C (73°F) or below]	$R_2 = 1.78 - 2.0$ mm (0.0701 - 0.0787 in)		
Unloader valve	Choke valve clearance when throttle valve is opened fully	$R_3 = 2.34 - 3.08$ mm (0.0921 - 0.1213 in)		
Interlock of primary and secondary throttle valves	Primary throttle valve clearance when secondary throttle valve starts to open	$G_2 = 5.34 \pm 0.62$ mm (0.2102 ± 0.0244 in)		
Dashpot adjustment	Primary throttle valve clearance when adjusting screw tip contacts dashpot rod	$G_3 = 0.70 \begin{smallmatrix} +0.9 \\ -0.1 \end{smallmatrix}$ mm (0.0276 $\begin{smallmatrix} +0.0354 \\ -0.0038 \end{smallmatrix}$ in)		
Idle switch adjustment	Primary throttle valve clearance when idle switch changes to ON/OFF	$G_4 = 0.79 \pm 0.11$ mm (0.0311 ± 0.0043 in)		
Float adjustment	Clearance between flat and upper mating surface of float chamber when float seat comes in contact with valve stem	$H = 12.3 - 13.3$ mm (0.484 - 0.524 in)		
	Clearance between valve stem and float seat when float is fully lowered	$L = 1.5 - 1.9$ mm (0.059 - 0.075 in)		
	Distance between top surface of float and matching surface of float chamber when float is fully lowered	$A = 46 - 48$ mm (1.81 - 1.89 in)		

C COMPONENT PARTS

1. Air Intake System and Air Cleaner



- 1 Resonator
- 2 Hot air duct
- 3 Duct holder
- 4 Air intake duct
- 5 Air cleaner cover
- 6 Air cleaner element
- 7 Air cleaner case
- 8 Stud
- 9 Gasket
- 10 Automatic temperature controller

Tightening torque: N·m (kg·m, ft·lb)
T: 6 - 7 (0.6 - 0.7, 4.3 - 5.1)

Fig. 14

B2-1034

2. Intake Manifold and Carburetor

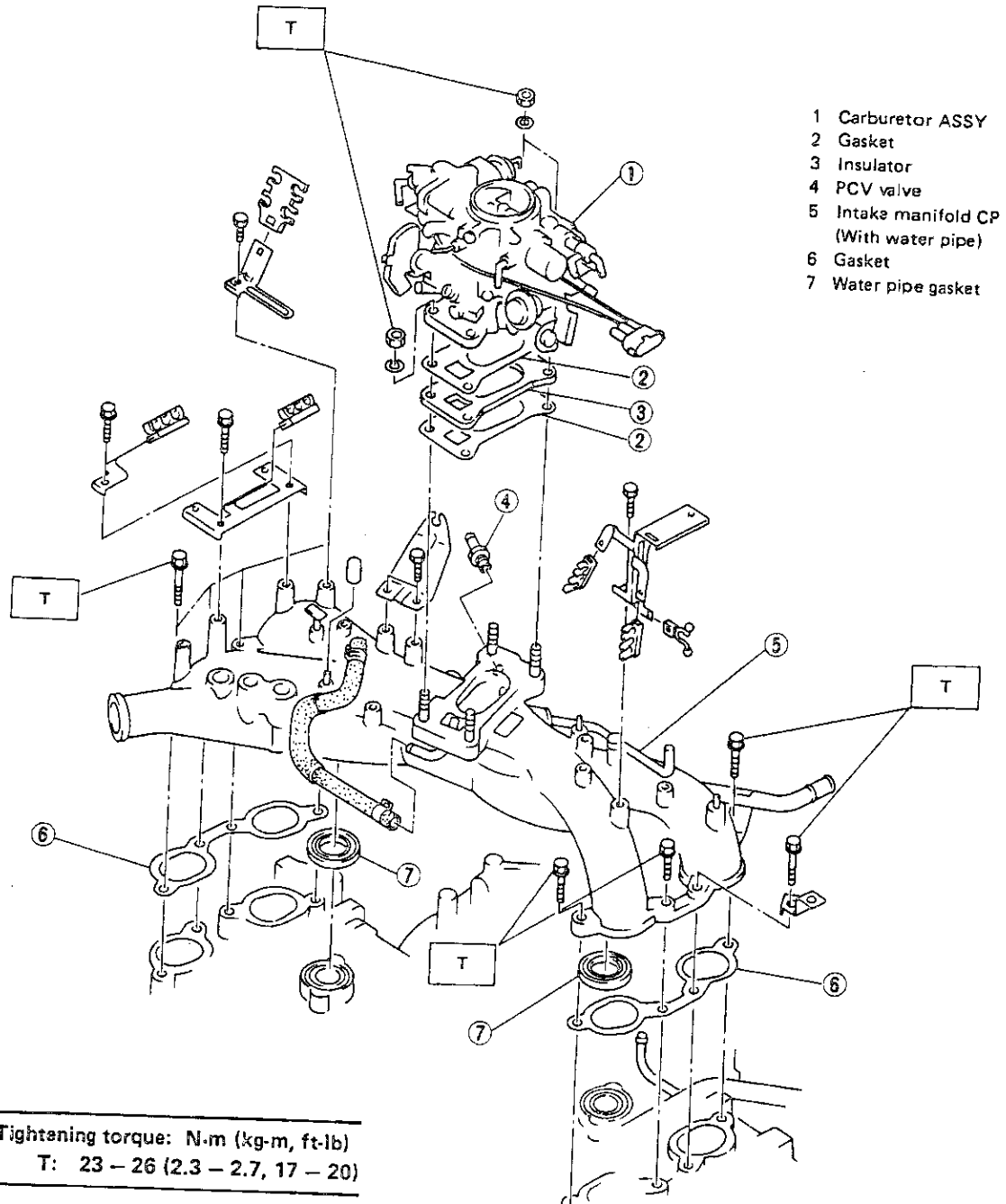


Fig. 15

3. Carburetor ASSY

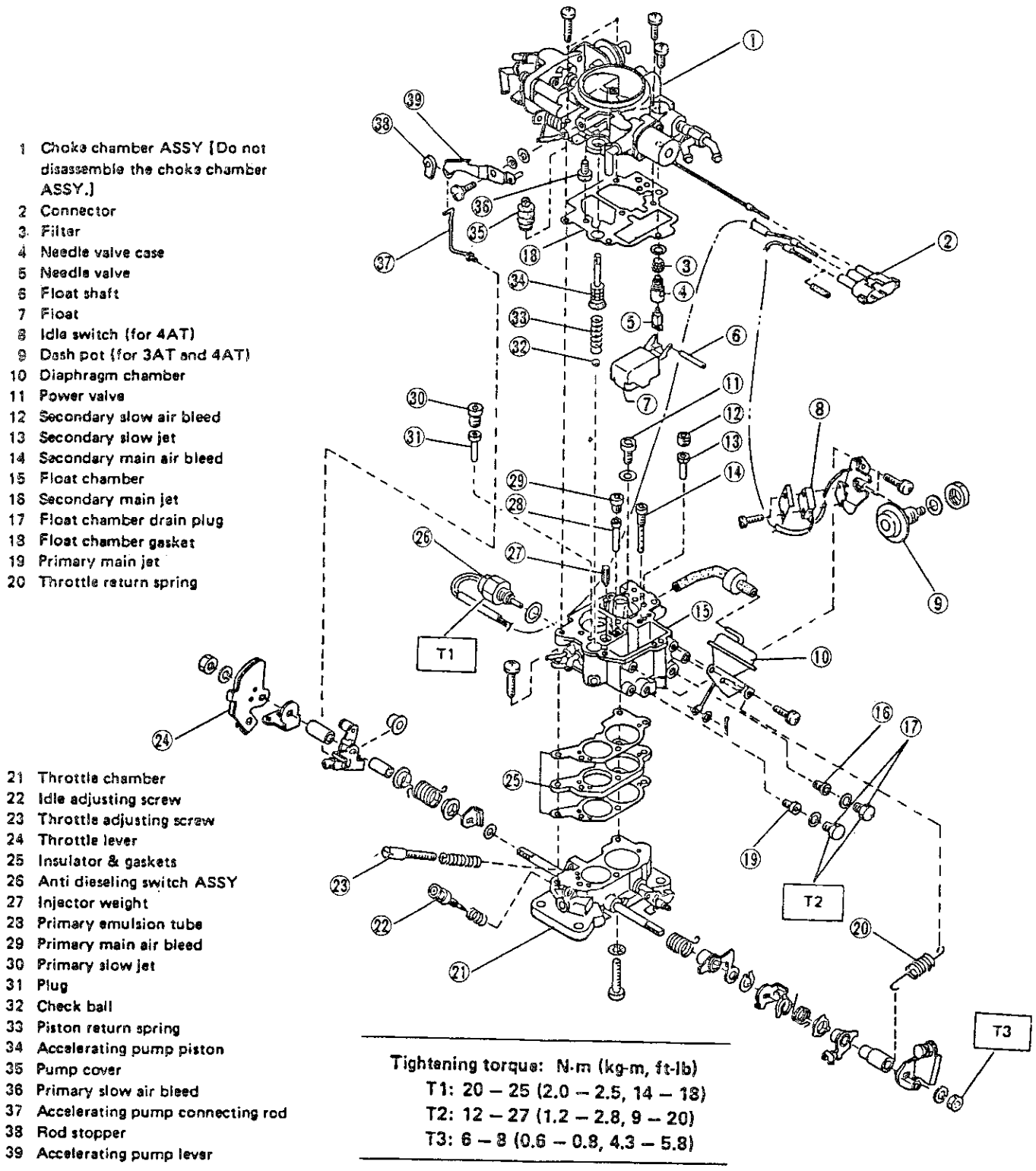


Fig. 16

B2-756

W SERVICE PROCEDURE

A: REMOVAL

- 1) Remove air cleaner.
- 2) Disconnect fuel delivery, return and air vent hoses.
- 3) Disconnect all hoses and tubes from carburetor.
- 4) Disconnect harness connector.
- 5) Disconnect accelerator cable from throttle lever.
- 6) Drain coolant so as to prevent it from flowing out.
- 7) Remove carburetor attaching nuts and carburetor.

After removal, cover the area on the intake manifold where the carburetor was installed, in order to prevent dust from entering into the engine.

B: DISASSEMBLY

1. PRECAUTIONS

- 1) Use wrenches and screwdrivers of proper size to remove nuts and screws. Be careful not to cause burr or damage.
- 2) Keep disassembled parts in order not to mix them up when reassembling.
- 3) Use clean gasoline and compressed air to clean the jets and fuel passages. Never use a wire or cloth.

2. REMOVING LINKAGE

- 1) Remove throttle return spring.
- 2) Remove pump lever shaft screw, pump lever, washer and spring washer, and then remove rod stopper.

3. REMOVING CHOKE CHAMBER

- 1) Unclamp harness.
- 2) Detach choke chamber and gasket from float chamber.

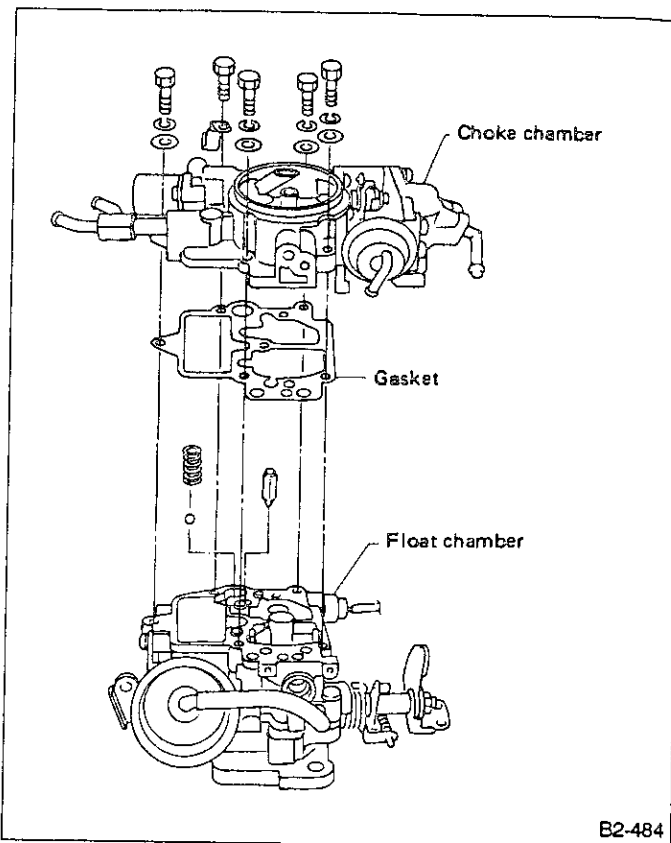


Fig. 17

- 3) Remove piston return spring, ball and injector weight from choke chamber.
- 4) Remove anti-dieseling switch with plunger, spring and gasket.

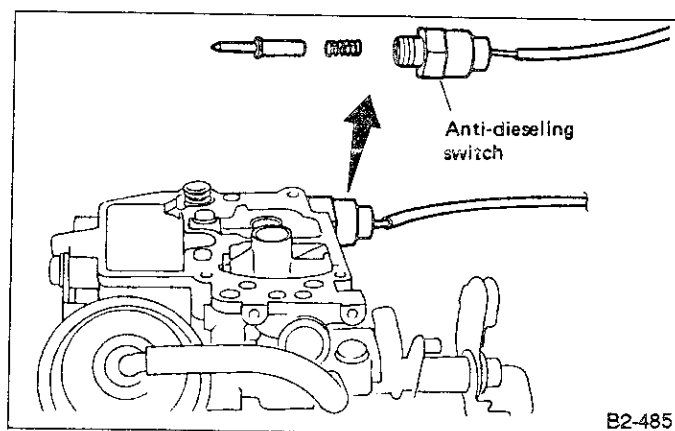


Fig. 18

4. SEPARATING FLOAT CHAMBER AND THROTTLE CHAMBER

- 1) Remove secondary diaphragm hose.
- 2) Remove snap ring and washer of secondary diaphragm rod.
- 3) Remove secondary diaphragm.

4) Separate float chamber and throttle chamber.

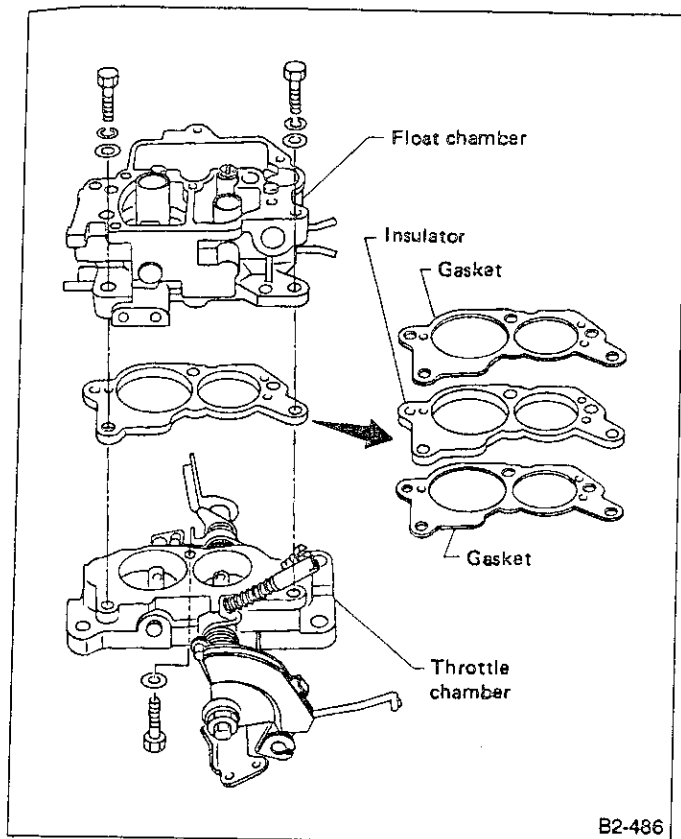


Fig. 19

5) Remove insulator and gasket.

Be careful not to damage the longest screw, since it has a hole which is vacuum passage for the power valve.

5. DISASSEMBLING CHOKE CHAMBER

1) Remove accelerating pump piston and pump cover.

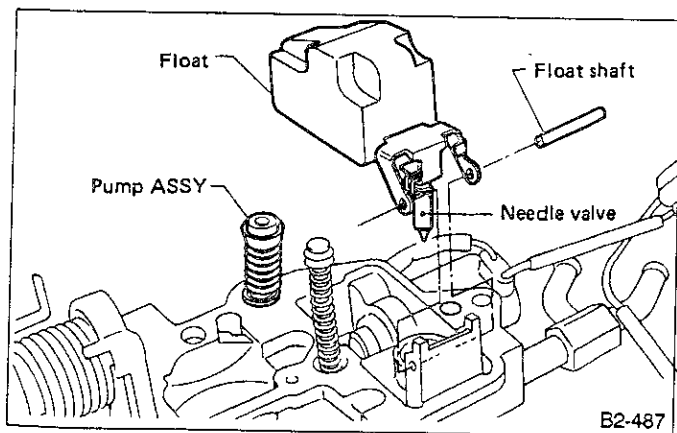


Fig. 20

- 2) Remove float shaft and float with needle valve.
- 3) Remove needle valve case.
- 4) Remove primary slow air bleed.

6. DISASSEMBLING FLOAT CHAMBER

1) Remove primary main air bleed and emulsion tube.

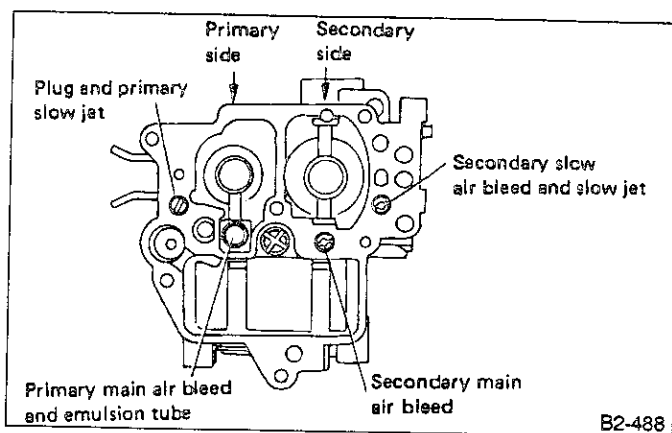


Fig. 21

- 2) Remove secondary main air bleed.
- 3) Remove plug and primary slow jet.
- 4) Remove secondary slow air bleed and slow jet.
- 5) Remove lock plate, float chamber drain plugs, and primary and secondary main jets.
- 6) Remove power valve.

7. DISASSEMBLING THROTTLE CHAMBER

- 1) Remove throttle adjusting screw and spring.
- 2) Remove idle adjusting screw and spring.

Special tool:

Idle adjust driver (498297100)

- 3) Remove nut and parts on throttle valve shaft.
 - a. Keep the disassembled parts in order.
 - b. Be careful not to damage the throttle shaft and throttle valve.

C: INSPECTION

Disassembled components should be washed in clean gasoline before inspection. Particularly small holes and hollows such as fuel passage must be blown with compressed air to remove dust and dirt. Do not use drills or wires to clean the small passages, otherwise the carburetor performance may be adversely affected due to cut or deformation.

1. CHOKE CHAMBER

- 1) Air horn
Check for cracks, damage on mating surfaces, damage on threads, and excessive wear of choke valve shaft contact areas.
- 2) Choke valve
Check for deformation and rust.
- 3) Choke valve shaft
Check for wear and twist.

4) Power piston

Check for correct operation.

5) Float

Check for deformation, damage of seat and stopper, and wear of float shaft hole.

6) Needle valve

Check for damage and correct contact against valve seat.

7) Filter

Check for deformation and damage.

8) Air bleed

Check for damage on thread and groove.

9) Accelerating pump cover

Check for crack and damage.

2. FLOAT CHAMBER

1) Float chamber body

Check for cracks, damage on mating surfaces, damage on threads, wear of auxiliary valve shaft hole, and wear of accelerating pump cylinder.

2) Injector weight

Check for damage and proper contact against seat.

3) Ball

Check for damage.

4) Piston return spring

Check for rust.

5) Jet

Check for damage on thread and groove.

6) Emulsion tube

Check for deformation.

7) Accelerating pump piston

Check for damage and wear.

8) Power valve

Check for correct operation and damage on thread and groove.

3. THROTTLE CHAMBER

1) Throttle chamber body

Check for cracks, damage on mating surfaces, wear of throttle valve shaft hole and damage on thread.

2) Throttle valve

Check for deformation.

3) Throttle valve shaft

Check for wear, twist, and damage on thread.

4) Idle mixture adjusting screw

Check for damage on tip of the screw.

5) Springs

Check for permanent set and rust.

4. OTHERS

1) Washer

Check for deformation and damage.

2) Linkage

Check for wear of each sliding part.

3) Passages

Check for clogging.

D: ASSEMBLY**1. PRECAUTIONS**

1) Wash all parts with clean gasoline before reassembly.

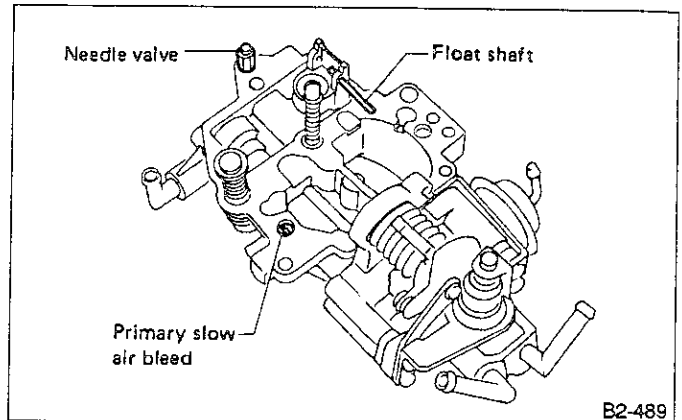
2) Use new gaskets, lock plate and cotter pins.

3) Use wrenches and screwdrivers of proper size to prevent damaging the parts.

2. ASSEMBLING CHOKE CHAMBER

1) Install needle valve case with washer.

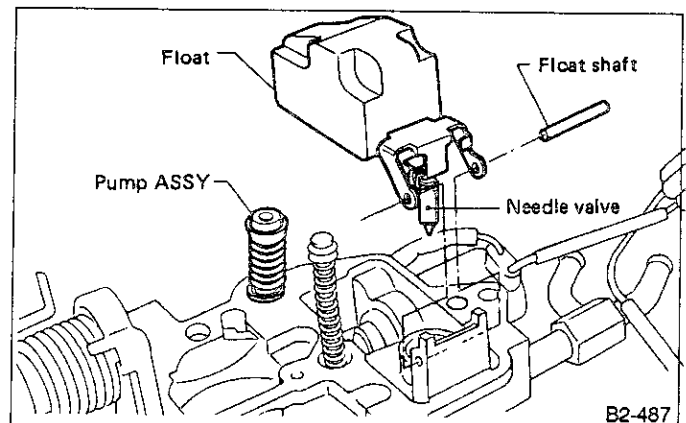
2) Install primary slow air bleed.



B2-489

Fig. 22

3) Install float with needle valve and float shaft, and adjust the float level.



B2-487

Fig. 23

4) Install accelerating pump piston and pump cover.

3. ASSEMBLING FLOAT CHAMBER

1) Install primary and secondary main jets and float chamber drain plugs with washers and install lock plate.

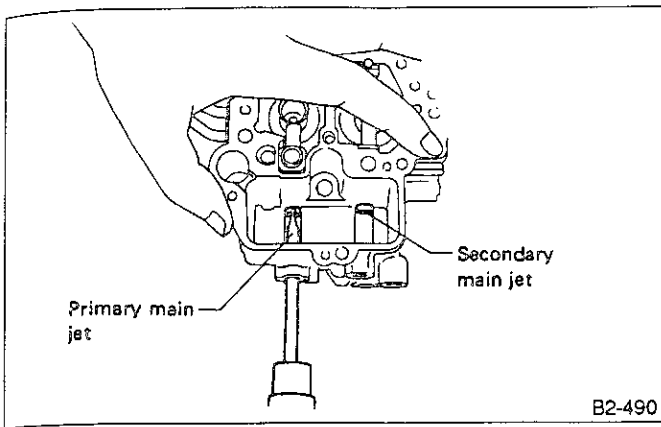


Fig. 24

- 2) Install power valve with washer.
- 3) Install secondary slow jet and slow air bleed.
- 4) Install primary slow jet and plug.
- 5) Install secondary main air bleed.
- 6) Install primary emulsion tube and main air bleed.

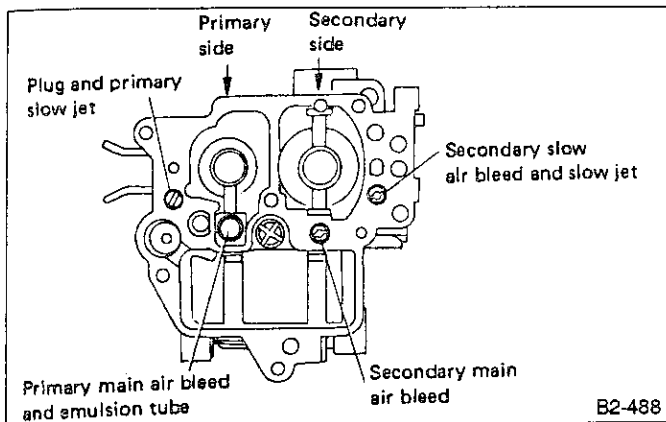


Fig. 25

4. ASSEMBLING THROTTLE CHAMBER

- 1) Install adjusting plate, lever, washer, sleeve, etc. onto throttle valve shaft.

Be careful not to damage the throttle shaft and throttle valve.

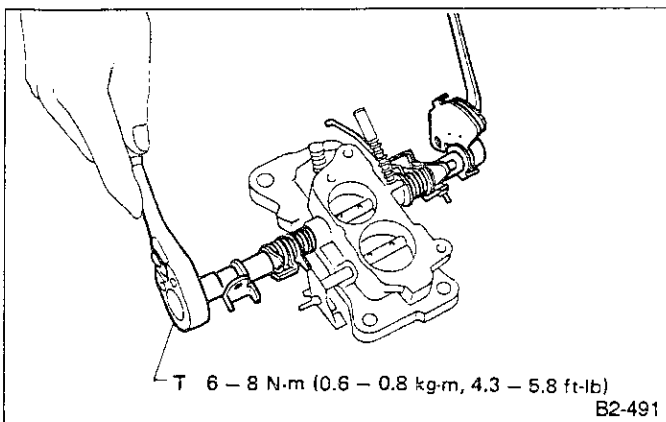


Fig. 26

- 2) Install throttle adjusting screw and spring.
- 3) Install idle adjusting screw and spring.

Special tool:
Idle adjust driver (498297100)

5. BRINGING FLOAT CHAMBER AND THROTTLE CHAMBER TOGETHER

- 1) Put float chamber and throttle chamber together with insulator and gaskets.
- 2) Install secondary diaphragm and connect with washer and snap ring, and connect hose.
- 3) Install injector weight, ball and piston return spring.

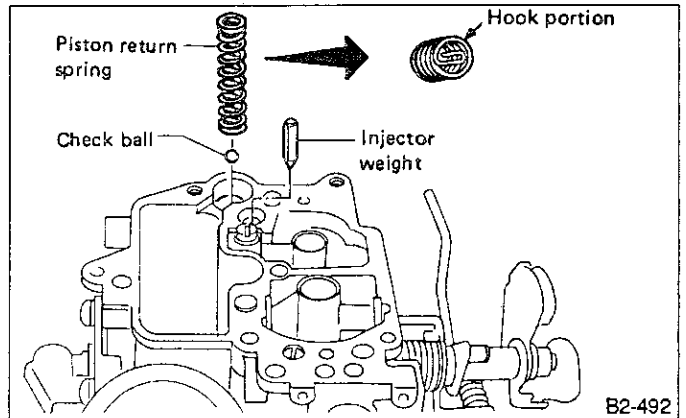


Fig. 27

Install return spring with its hook portion facing downward.

6. INSTALLING CHOKE CHAMBER

- 1) Install anti-dieseling switch with plunger, spring and washer.

Connect wiring harness. Be careful not to twist it.

- 2) Position choke chamber on float chamber with gasket and tighten screws.

7. INSTALLING LINKAGE

- 1) Connect accelerating pump connecting rod to pump lever with rod stopper by inserting the rod end into the hole in pump lever, and lock rod stopper.

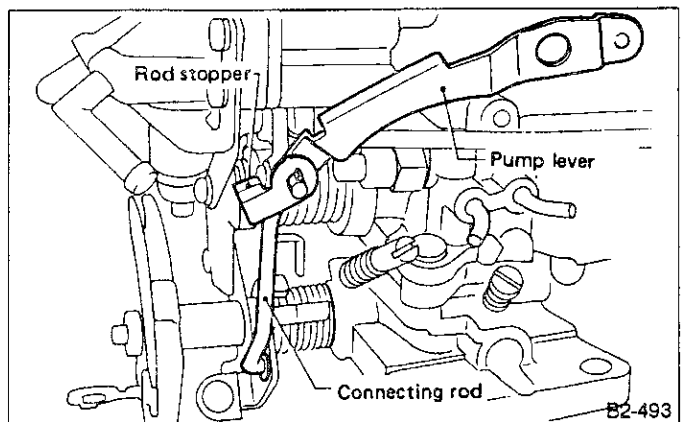


Fig. 28

- 2) Install pump lever with pump lever shaft screw, spring, plain washer, and spring washer.

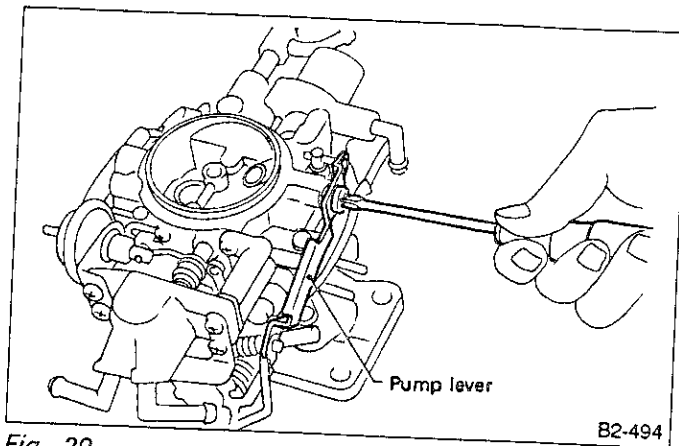


Fig. 29

B2-494

- 3) Install throttle return spring.

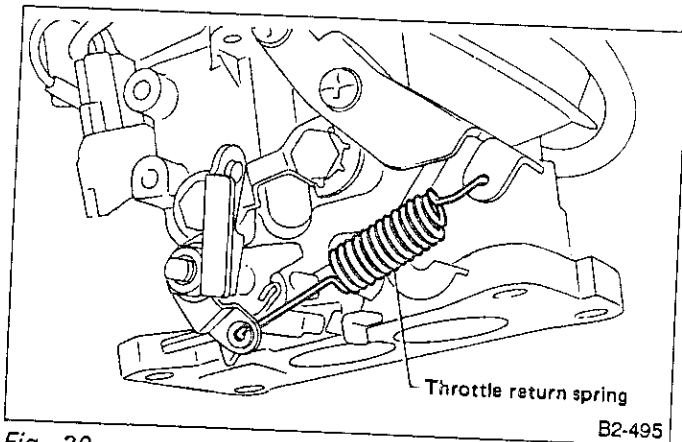


Fig. 30

B2-495

- 4) Make sure that all the linkage operates smoothly.

E: INSTALLATION

Installation is in the reverse order of removal.

Observe the following:

- 1) After reinstallation, make sure that no leakage exists around the mating parts and that the vacuum system operates correctly.
- 2) Perform "Engine idle speed adjustment" and "Engine idle mixture adjustment".

F: REPLACEMENT

1. MAIN JET

1) Removal

Before servicing, be sure to disconnect battery (-) terminal.

- (1) Remove drain plug (on secondary side).

Pay attention to gasoline that leaks.

- (2) Loosen main jet using MAIN JET SCREWDRIVER (CARBURETOR TOOL SET 498017000).

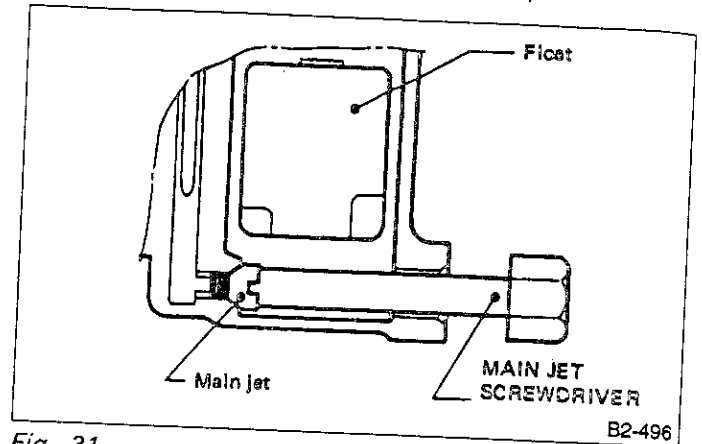


Fig. 31

B2-496

- (3) Insert MAIN JET HOOK (CARBURETOR TOOL SET 498017000) through hole of MAIN JET SCREWDRIVER and hook to main jet.

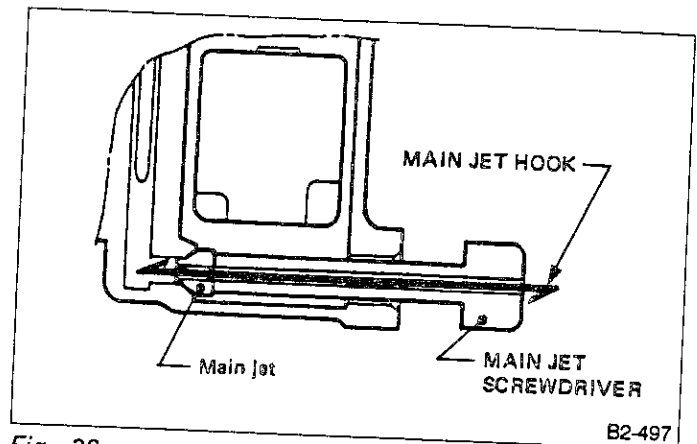


Fig. 32

B2-497

- (4) Loosen MAIN JET SCREWDRIVER further and pull out MAIN JET SCREWDRIVER and MAIN JET HOOK together with main jet.

2) Installation

- (1) While lifting up float by an L-shaped metal wire as illustrated below to prevent its interference with main jet path, insert main jet using MAIN JET SCREWDRIVER and then tighten.

a. When installing secondary side main jet, insert L-shaped metal wire to primary side as illustrated and turn it in direction of arrow (counterclockwise) to lift up float.

b. When installing primary side main jet, insert L-shaped metal wire to secondary side as illustrated and turn it in opposite direction (clockwise) to lift up float.

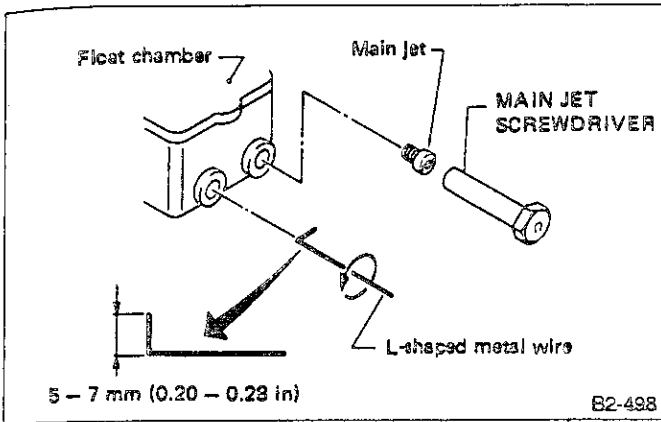


Fig. 33

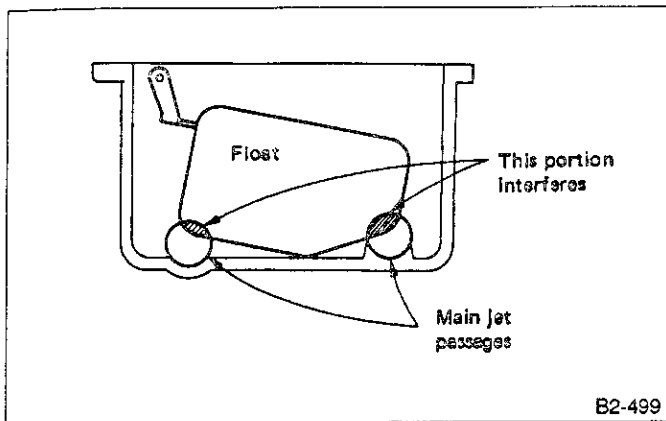


Fig. 34

(2) After replacement of main jet, install removed parts in reverse order of removal.

- a. Attach new gasket and lock plate together with drain plug.
- b. Should main jet have been dropped in float chamber be sure to take it out by removing choke chamber.

G: CHECK AND ADJUSTMENT

1. FAST IDLE OPENING ADJUSTMENT

1) Set carburetor in a place where ambient temperature is stable and measure throttle valve clearance G_1 and choke valve clearance R_1 . Compare the values with those for the temperatures shown in the table below.

Temperature		- 10	0	10	20	25	30
°C (°F)		(14)	(32)	(50)	(68)	(77)	(96)
Standard value of G_1 mm (in)	MT	1.28 (0.0504)	1.00 (0.0394)	0.76 (0.0299)	0.64 (0.0252)	0.5 - 0.68 (0.0197 - 0.0268)	0.55 (0.0217)
	3AT	1.36 (0.0535)	1.00 (0.0394)	0.84 (0.0331)	0.68 (0.0268)	0.5 - 0.68 (0.0197 - 0.0268)	0.54 (0.0213)
	4AT	1.70 (0.0669)	1.36 (0.0535)	1.12 (0.0441)	0.80 (0.0315)	0.68 - 0.90 (0.0268 - 0.0354)	0.68 (0.0268)

Standard value of R_1 at 25°C (77°F):
 0.7 — 0.95 mm (0.0276 — 0.0374 in)

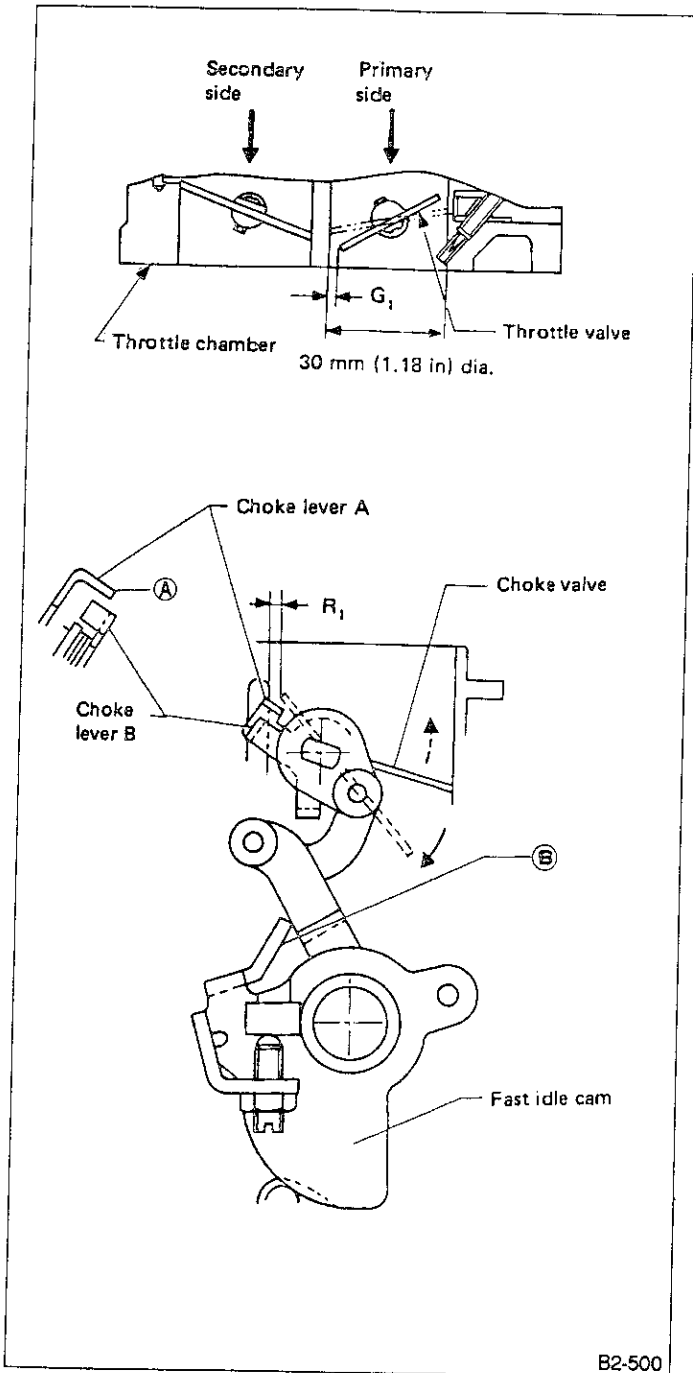


Fig. 35

2) Turn the adjusting screw right or left to adjust the clearance G_1 to specification.

Turning adjusting screw clockwise:
 decreases G_1
 Turning adjusting screw counterclockwise:
 increases G_1

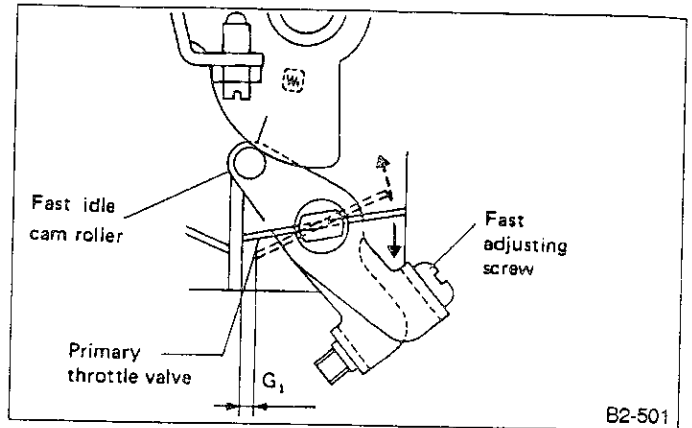


Fig. 36

3) When R_1 is outside specifications, adjust by bending claw (A). If doing this cannot correct R_1 value, then bend claw (B).

2. VACUUM BREAK OPENING ADJUSTMENT

1) Be sure that the choke valve is fully closed.
 (When ambient temperature is 23°C (73°F) or below, choke valve closes fully due to operation of wax element.)
 Operate choke opener by applying -53.3 kPa (-400 mmHg, -15.75 inHg) of vacuum and measure the dimension of R_2 .

Standard clearance R_2 :
 1.78 — 2.0 mm (0.0701 — 0.0787 in)

2) Adjustment can be made by bending choke lever.

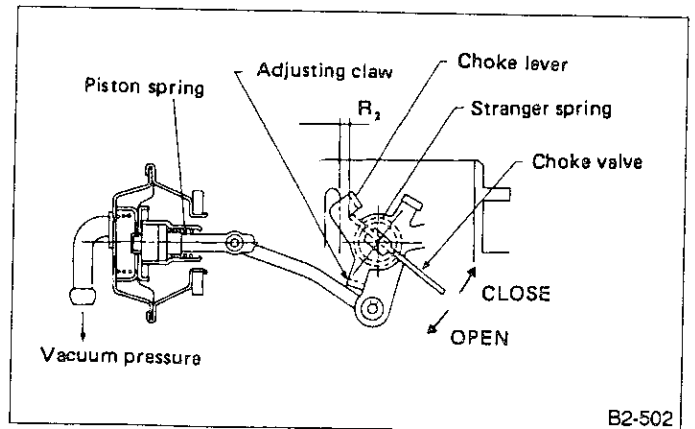


Fig. 37

3. ANTI-DIESELING SWITCH

1) While the engine is idling, disconnect the lead wire from the anti-dieseling switch to ensure the engine stops.

The anti-dieseling switch is properly operating if the engine stops.

2) If the engine discontinues to idle after it has started, the problem may be due to a broken lead wire or a faulty electrical system.

3) The anti-dieseling switch is malfunctioning if the engine afterfires when the ignition switch is turned off.

4. UNLOADER VALVE

1) Hand-rotate throttle lever to open throttle valve fully.

2) With throttle valve held in that position, measure choke valve position R_3 .

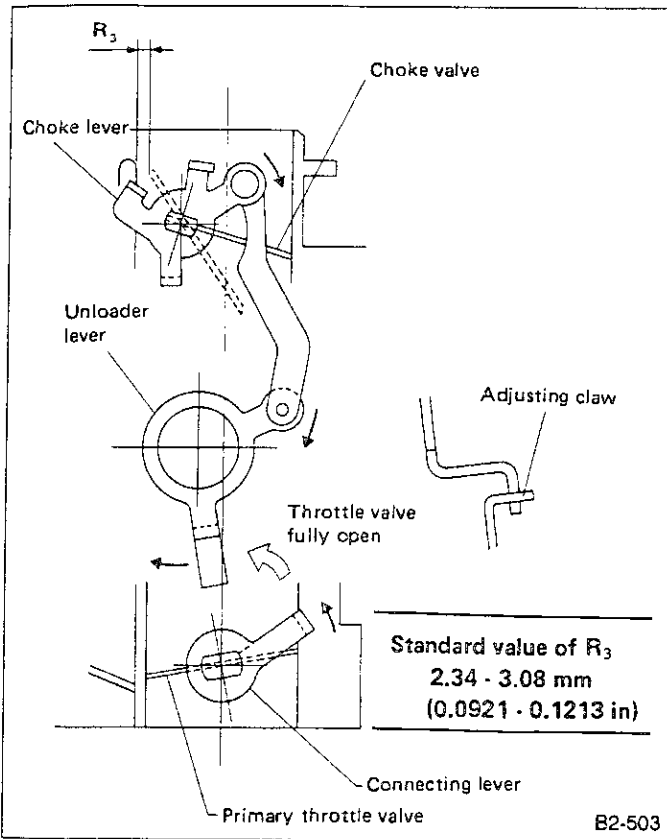


Fig. 38

3) When R_3 is outside specifications, adjust by bending the unloader lever's adjusting claw.

5. DELAY VALVE

- 1) Check delay valve.
- 2) If it is clogged, replace.

Performance characteristic of delay valve (for reference)

Air flow [at -66.7 kPa (-500 mmHg, -19.69 inHg) vacuum pressure]:

100 cc (3.4 US fl oz, 3.5 Imp fl oz)/min

6. ADJUSTMENT FOR INTERLOCK OF PRIMARY AND SECONDARY THROTTLE VALVES

The primary and secondary throttle valves are interlocked so that the secondary throttle valve starts to open when the primary throttle valve is opened to a certain degree. This opening angle of the primary throttle valve clearance G_2 should be as follows.

Standard clearance G_2 :

5.34 ± 0.62 mm (0.2102 ± 0.0244 in)

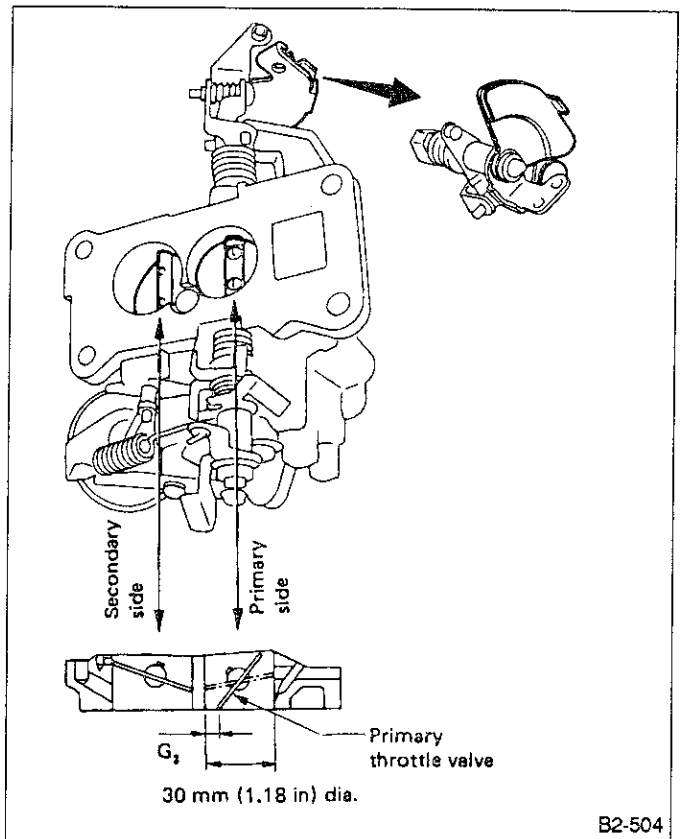


Fig. 39

7. DASHPOT [EXCEPT MANUAL TRANSMISSION VEHICLES]

1) While holding fast idle cam with pliers, align hole in idle cam with hole in bracket. Insert pin into the holes to set throttle valve to the "fully-close" position.

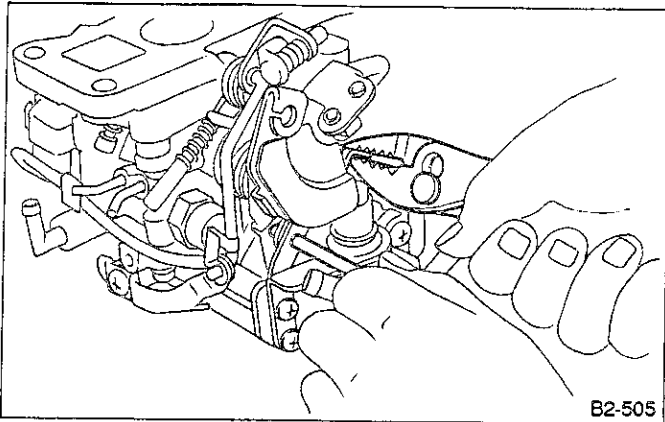


Fig. 40

2) Hand-rotate throttle lever. When adjusting screw tip contacts dashpot rod, measure dimension "G₃".

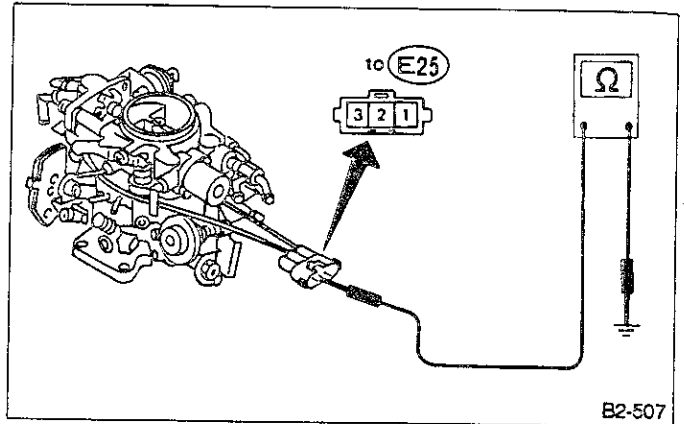


Fig. 42

If either or both resistance values are outside specifications, replace with a new microswitch.
3) Check that terminal resistance properly changes, as indicated below, when throttle valve clearance is "G₄".

Clearance G₄:

More than 0.79 ± 0.11 mm (0.0311 ± 0.0043 in)
Terminal/Specified resistance
No. 2 — Ground/1 MΩ min → 0Ω

If it does not change, adjust by bending the adjusting claw of adjusting plate.

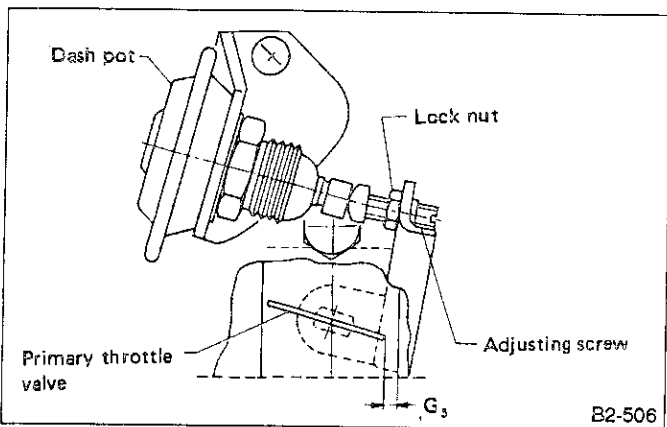


Fig. 41

Standard value G₃:

0.70 ± 0.09 mm (0.0276 ± 0.0035 in)

3) If "G₃" is outside specifications, adjust by turning adjusting screw.

8. IDLE SWITCH [4AT]

1) Set throttle valve to the "fully-close" position. (Refer to "7. Dashpot".)

2) Measure resistance values between microswitch terminals when throttle valve is fully open (switch lever is away from the contact point) and when it is fully closed (when switch lever is in close contact with the switch contact point).

Terminal/Specified resistance:

No. 2 — Ground/1 MΩ (fully closed)
0 Ω (fully open)

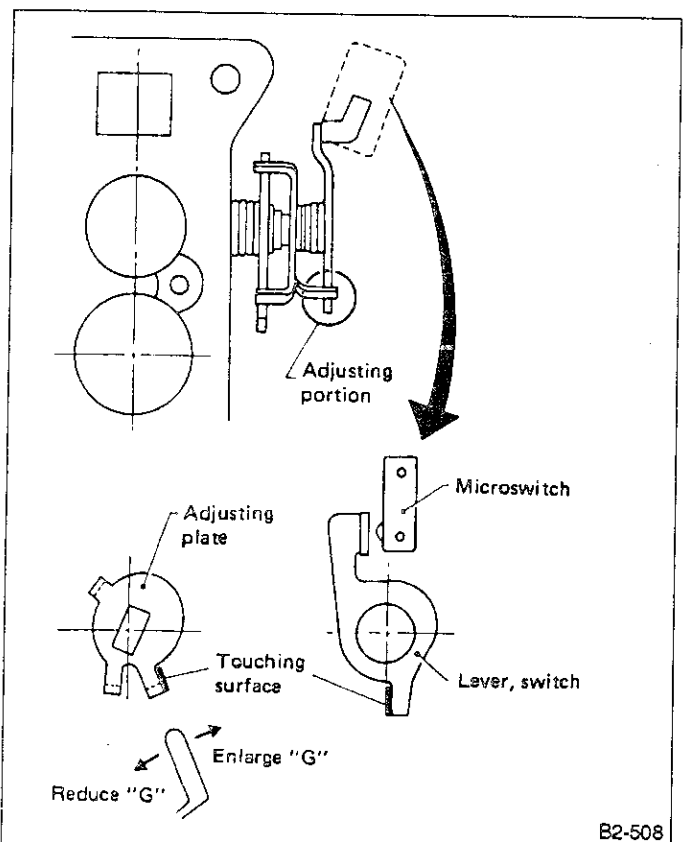


Fig. 43

9. FLOAT LEVEL

1) Measurement

Before servicing, be sure to disconnect battery (-) terminal.

(1) Remove drain plug (on secondary side).

Pay attention to gasoline that leaks.

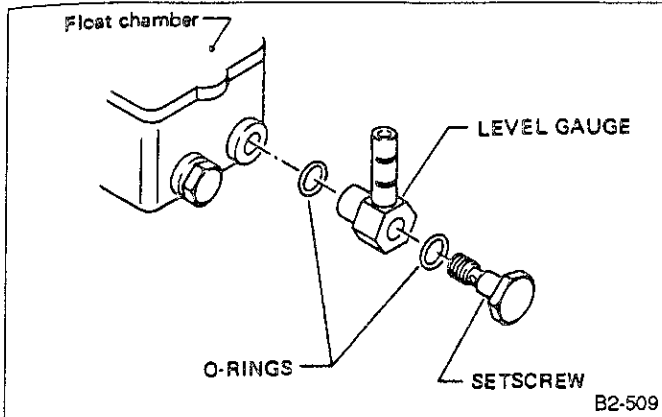


Fig. 44

- (2) Install O-RINGS, LEVEL GAUGE and SETSCREW (CARBURETOR TOOL SET 498017000).
- (3) Connect battery (-) terminal and start engine.
- (4) Check the float level.
 - (a) Do not install air cleaner.
 - (b) Operate with vehicle in level position.
 - (c) Install LEVEL GAUGE vertically to carburetor and observe fuel level horizontally.
 - (d) Measure after fuel level has stabilized during idling.

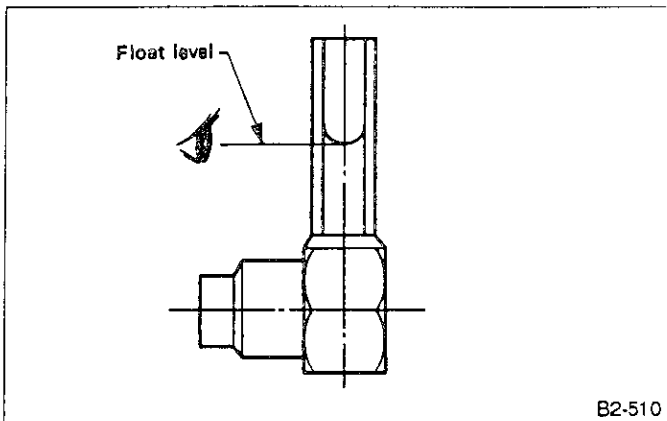


Fig. 45

Float level is normal if the level is within two blue lines.

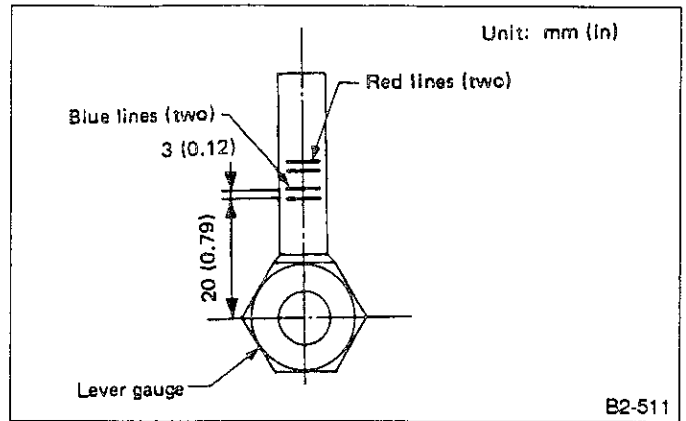


Fig. 46

(5) After measurement, install removed parts in reverse order of removal.

Attach new gasket and lock plate together with drain plug.

(6) If the float level is not within the specified range, adjust the float level.

2) Adjustment

(1) Adjusting float level

Remove the choke chamber and turn it upside down. If the clearance H indicated in the figure is as specified below when the float seat comes in contact with the valve stem, the float level is normal. If not, adjust the level by bending the float seat.

Clearance H:

12.3 — 13.3 mm (0.484 — 0.524 in)

(2) Adjusting needle valve stroke

There are two methods in adjusting stroke.

(a) After removing the hook from valve stem, measure the clearance "L" between the float seat and valve stem with the float fully lifted. If the measurement is out of spec., adjust by bending the stopper. After completion of adjustment, be sure to fit the hook.

(b) Adjust by bending the stopper so that "A" is within the spec. with the float fully lifted.

Clearance L:

1.5 — 1.9 mm (0.059 — 0.075 in)

Distance A:

46 — 48 mm (1.81 — 1.89 in)

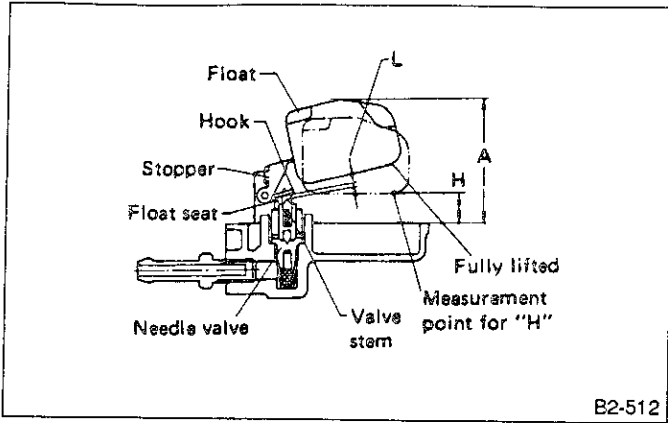


Fig. 47

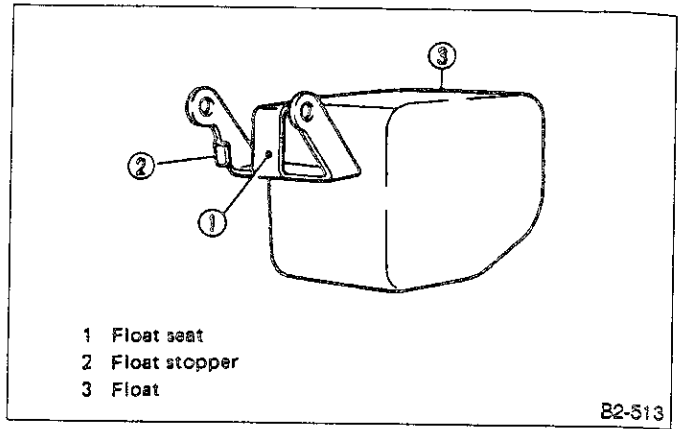


Fig. 48

T TROUBLESHOOTING

Before troubleshooting, make certain that the ignition system and fuel line function correctly.

Trouble and possible cause	Corrective action
1. Overflow	
(1) Poor contact between needle valve and valve seat, or damaged contact surfaces	Clean or lap contact surfaces, or replace.
(2) Improper float level adjustment	Readjust float level.
(3) Worn float seat or float stopper	Replace float.
(4) Worn float shaft	Replace.
(5) Damaged float chamber gasket or loose screw	Replace gasket or retighten screw.
(6) High fuel pump discharge pressure	Inspect and repair or replace fuel pump.
2. Excessive fuel consumption	
(1) Overflow	See items for "1. Overflow".
(2) Improper number of main jet or slow jet	Replace.
(3) Clogged air bleed	Clean or replace.
(4) Defective power valve or vacuum leaking from power valve system	Inspect and repair or replace.
(5) Defective accelerating pump injector weight seat	Inspect and repair or replace.
(6) Loose plugs or jets, or damaged gaskets	Retighten or replace.
(7) Improper opening of choke valve	Inspect and repair linkage.
(8) Improper opening of secondary throttle valve	Inspect and repair linkage.
3. Rough idle	
(1) Improper idle adjustment	Adjust.
(2) Damaged idle mixture adjusting screw	Replace.
(3) Clogged idle hole, by-pass hole, or slow system passage	Clean.
(4) Clogged slow jet	Clean.
(5) Worn throttle valve shaft	Replace.
(6) Damaged or improperly tightened gasket under carburetor	Replace or retighten.
(7) Leaking vacuum hoses	Inspect and replace.
(8) Overflow	See items for "1. Overflow".
4. Low output	
(1) Clogged main jet	Clean.
(2) Improper throttle valve opening	Inspect and adjust.
(3) Improper choke valve opening	Inspect and adjust.
5. Hesitation	
(1) Clogged slow jet, main jet, or emulsion tube	Clean.
(2) Clogged by-pass hole or slow system passage	Clean.
(3) Improper idle adjustment	Inspect and adjust.
(4) Malfunction of secondary throttle valve	Adjust.
6. Poor acceleration	
(1) Defective accelerating pump piston or piston return spring	Replace.
(2) Malfunction of accelerating pump inlet valve or outlet valve	Replace.
(3) Clogged pump nozzle	Clean.
(4) Malfunction of accelerating pump linkage	Repair.
(5) Defective power valve	Replace.
(6) Malfunction of power valve piston	Inspect and replace.
(7) Improper float level	Adjust float level.
(8) Malfunction of throttle valve	Adjust.
7. Poor high-speed performance	
(1) Clogged main jet	Clean.
(2) Improper throttle valve opening	Adjust.
(3) Worn throttle valve shaft	Replace.

Trouble and possible cause	Corrective action
(4) Improper float level	Adjust float level.
(5) Damaged gaskets	Replace.
8. Difficulty in starting at low temperatures	
(1) Malfunction of choke valve	Adjust.
(2) Malfunction of choke linkage	Adjust.
(3) Improper fast idle opening	Adjust.
(4) Improper adjustments of automatic choke	Adjust.
(5) Clogged delay valve	Replace.
9. Difficulty in idling the engine	
(1) Improper anti-dieseling solenoid valve operation	Check solenoid valve and harness. Repair or replace.
(2) Obstruction in slow system (Primary slow jet/primary slow air bleed clogged)	Clean.

SUBARU.

1992

**SERVICE
MANUAL**

	Page
M MECHANISM AND FUNCTION	2
1. General	2
2. Air Line	4
3. Fuel Line	6
4. Sensor and Switch	8
5. Control System	12
6. Self-diagnosis System	23
T TROUBLESHOOTING	26
1. Precautions	26
2. Pre-inspection	26
3. Troubleshooting Chart for Self-diagnosis System	27
4. Output Modes of Select Monitor	32
5. Control Unit I/O Signal	34
6. Troubleshooting for Engine Starting Failure	37
7. Troubleshooting Chart with Trouble Code	46
8. Troubleshooting Chart with Select Monitor	84
9. General Troubleshooting Table	93



M MECHANISM AND FUNCTION

1. General

The Multi Point Fuel Injection (MPFI) system is a system that supplies the optimum air-fuel mixture to the engine for all the various operating conditions through the use of the latest electronic technology.

With this system fuel, which is pressurized at a constant pressure, is injected into the intake air passage of the cylinder head. The injection quantity of fuel is controlled by an intermittent injection system where the electro-magnetic injection valve (fuel injector) opens only for a short period of time, depending on the quantity of air required for one cycle of operation. In actual operation, the injection quantity is determined by the duration of an electric pulse applied to the fuel injector and this permits simple, yet highly precise metering of the fuel.

Further, all the operating conditions of the engine are converted into electric signals, and this results in additional features of the system, such as large improved adaptability, easier addition of compensating element, etc. The MPFI system also has the following features:

- 1) Reduced emission of harmful exhaust gases.
- 2) Reduced in fuel consumption.
- 3) Increased engine output.
- 4) Superior acceleration and deceleration.
- 5) Superior startability and warm-up performance in cold weather since compensation is made for coolant and intake air temperature.

[Non-TURBO]

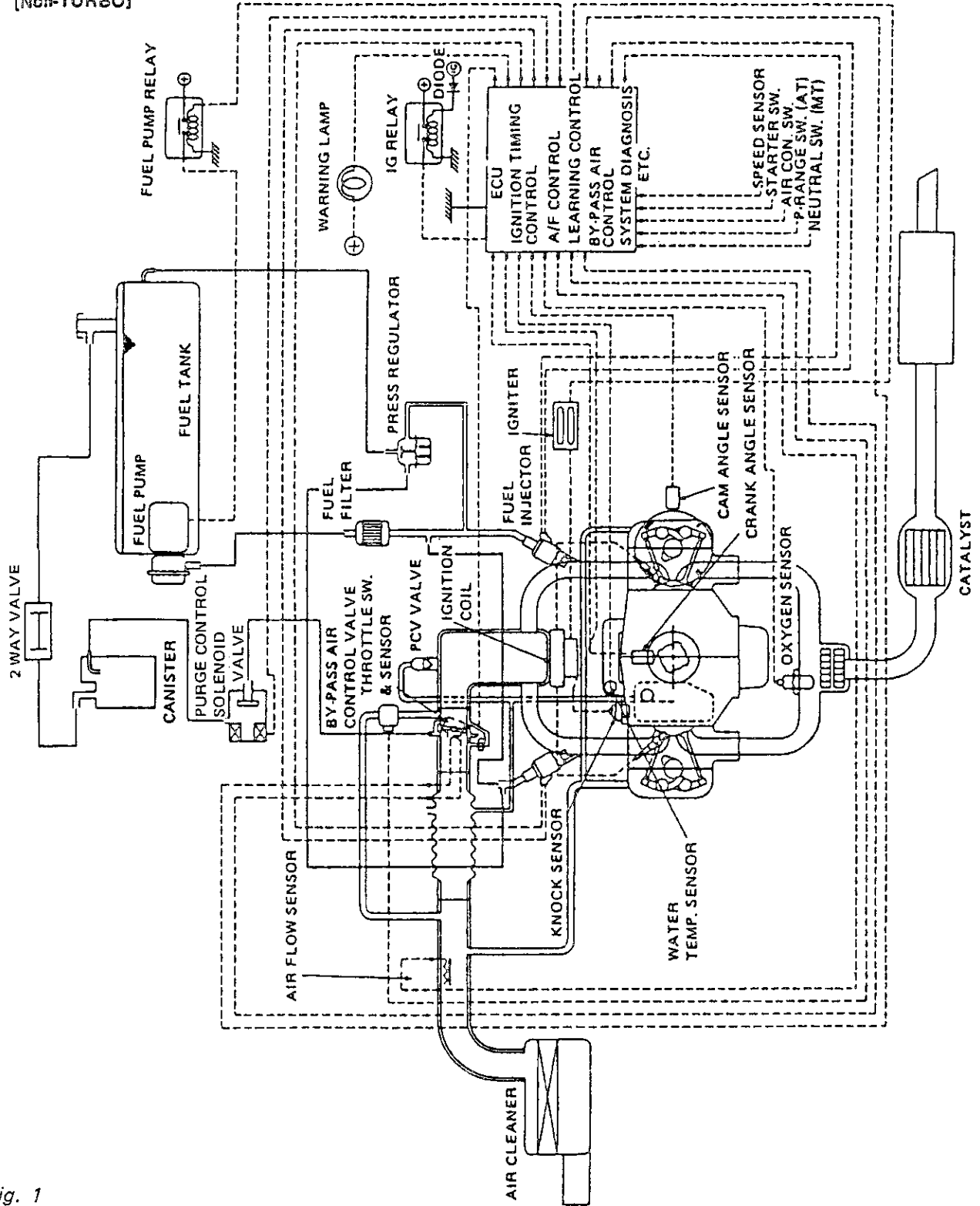
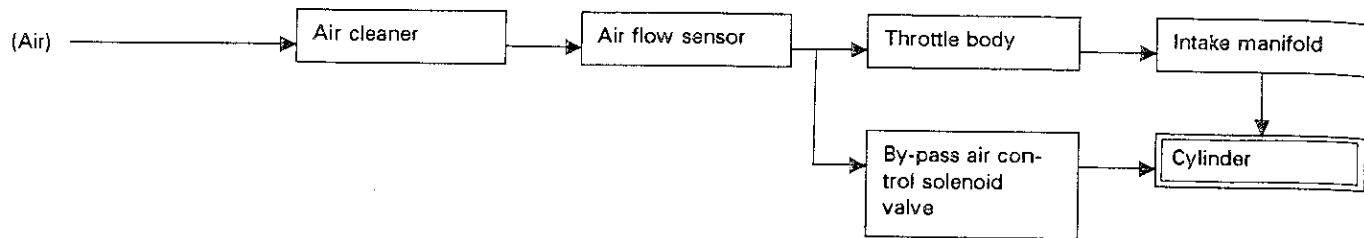


Fig. 1

2. Air Line

1. GENERAL

Air which is drawn in and filtered by the air cleaner is metered and sent to the throttle body via the air intake boot. From the throttle body, the air is regulated by the open-close operation of the throttle valve and is deliv-



2. AIR FLOW SENSOR

The MPFI system employs a hot-film type air flow sensor.

These air flow sensors convert the amount of air taken into the engine into an electric signal by utilizing the heat transfer phenomenon between the incoming air and a heating resistor (hot film) located in the air intake. The features of these flow sensor types are as follows:

- 1) High-altitude compensation is made automatically.
- 2) Quick response.
- 3) There are no moving parts.
- 4) They are compact.

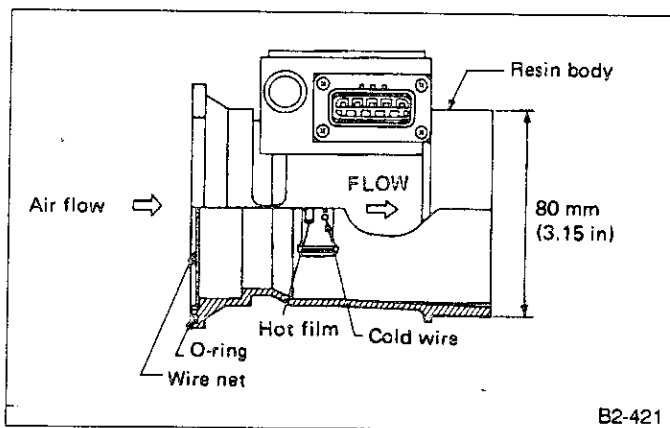


Fig. 2

ered to the intake manifold. It is then distributed to the respective cylinders to mix with fuel injected by the fuel injectors. Thus, the air-fuel mixture is delivered into the cylinder. Part of the air branched at the upstream of the throttle body is sent to the by-pass air control solenoid valve which regulates engine idle speed.

3. THROTTLE BODY

In response to the depressing stroke of the throttle pedal, the throttle body opens/closes its valve to regulate the air volume to be taken in the combustion chamber.

During idling, the throttle valve is almost fully closed and the air flow through the throttle body is less than that passing through the carburetor.

More than half of the air necessary for idling is supplied to the intake manifold via the by-pass air control solenoid valve.

And the by-pass air control solenoid valve properly controls the number of revolutions in idling, so it does not need to be adjusted.

4. THROTTLE SENSOR

A throttle sensor is provided with a potentiometer and idle switch interlocked with the throttle valve shaft is utilized.

This throttle sensor sends the MPFI control unit a potentiometer output signal corresponding to the opening of the throttle valve and an idle switch signal that turns ON only when the throttle is opened nearly to the idle position.

Using these signals, the MPFI control unit precisely controls the air-fuel ratio during acceleration and deceleration as well as idling.

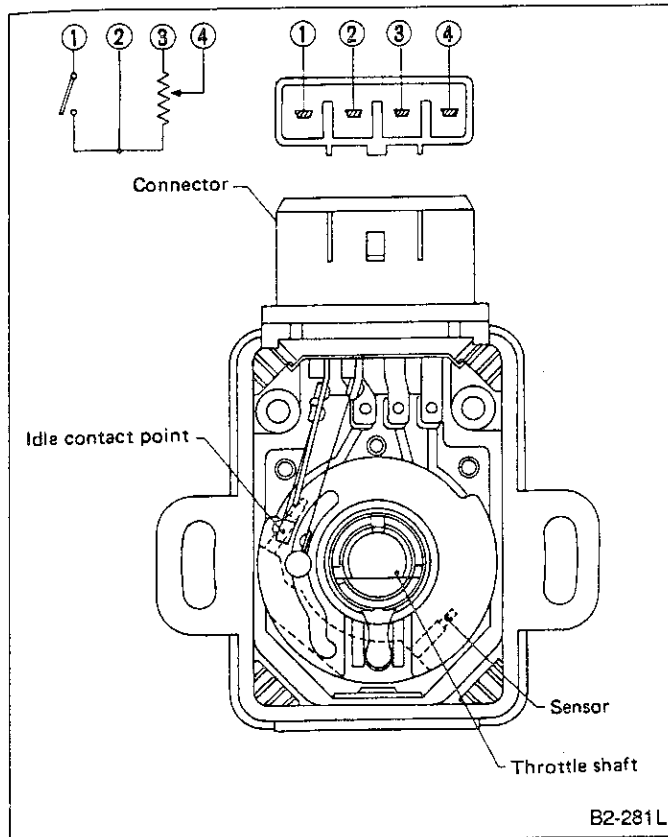


Fig. 3

5. BY-PASS AIR CONTROL SOLENOID VALVE

The by-pass air control solenoid valve consists of an air cut valve, duty control valve, intake air passage and a coolant passage.

The air cut valve contains a bimetallic substance which responds to coolant temperature, and a duty control valve which is operated by a signal sent from the ECU. When the coolant temperature is low, the air cut valve is fully opened by the action of the bimetallic substance so that the air flow required for low coolant temperatures is maintained.

The ECU controls the duty control valve to bring the operating engine speed as close to preset idle speed as possible.

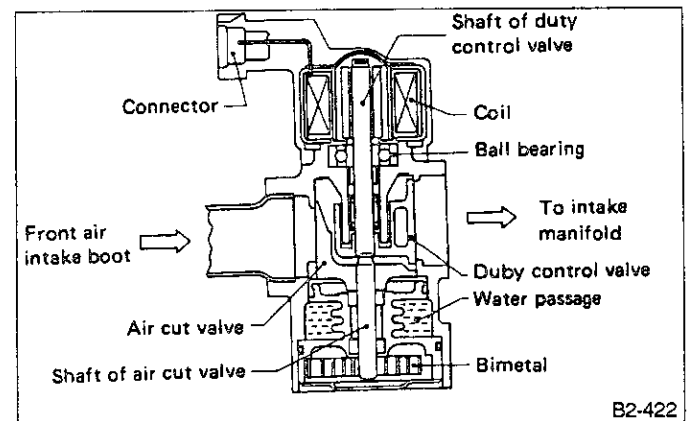


Fig. 4

3. Fuel Line

1. GENERAL

Fuel pressurized by the fuel pump built into the fuel tank is delivered to fuel injectors by way of the fuel pipe and fuel filter. Fuel is regulated to the optimum pressure level by the pressure regulator on the way to the injectors.

From the injectors, fuel is injected into the intake manifold where it is mixed with intake air, and is then delivered to the respective cylinders.

Fuel injection timing and the amount of fuel injected is regulated by the ECU.

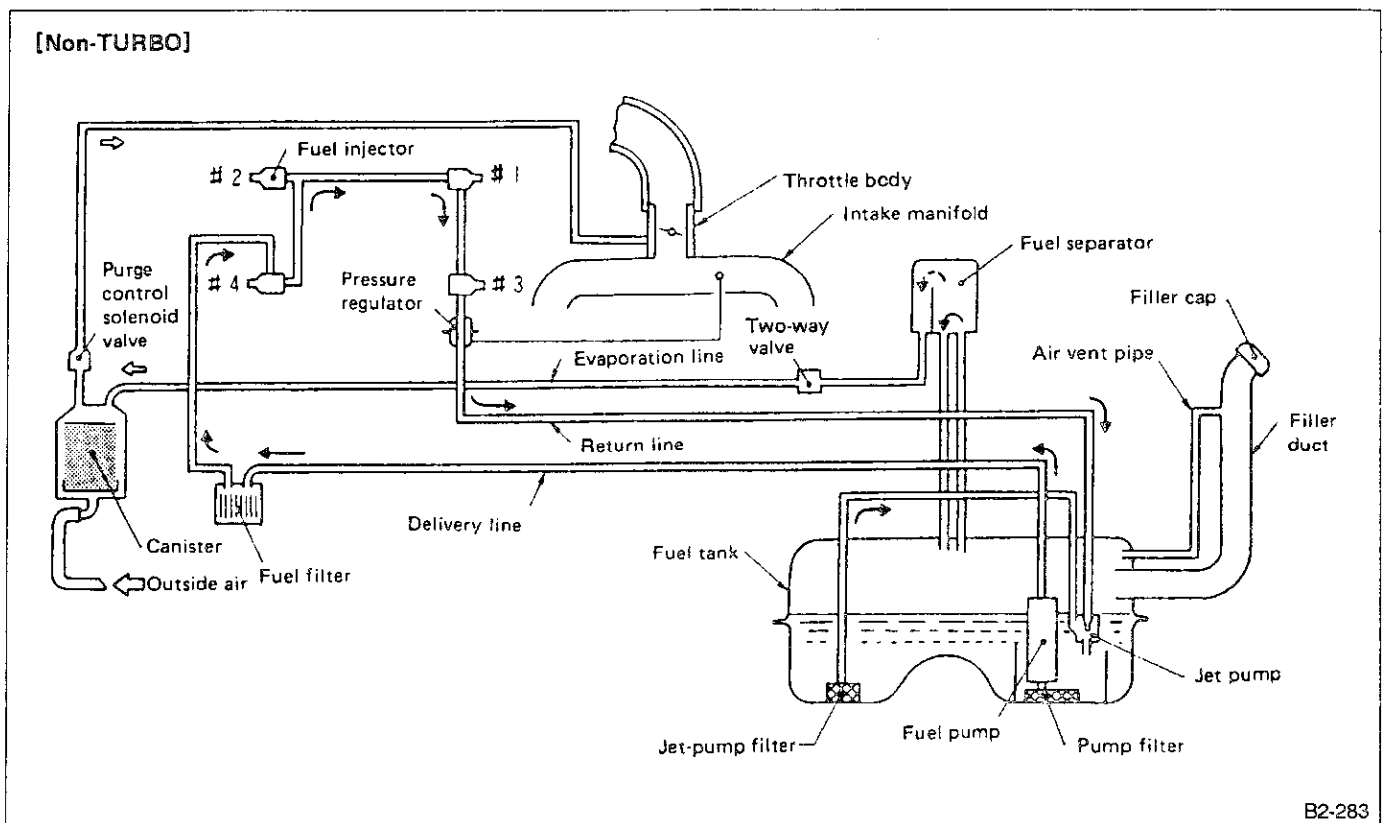
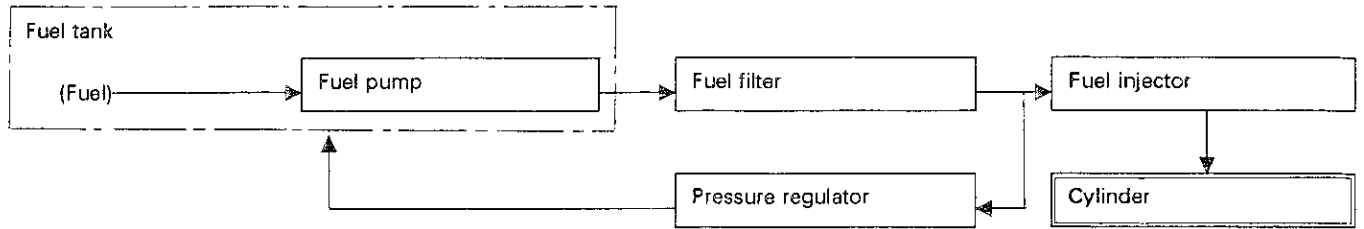


Fig. 5

2. PRESSURE REGULATOR

The pressure regulator is divided into the fuel chamber and the spring chamber by the diaphragm as illustrated below. Fuel is fed to the fuel chamber through the fuel inlet connected with the injector. A difference in pressure between the fuel chamber and the spring chamber connected with the intake manifold causes the diaphragm to be pushed down, and fuel is fed back to the fuel tank through the return line.

By returning fuel so as to balance the above pressure difference and the spring force, the fuel pressure is kept at a constant level 250.1 kPa (2.55 kg/cm², 36.3 psi) against the intake manifold pressure.

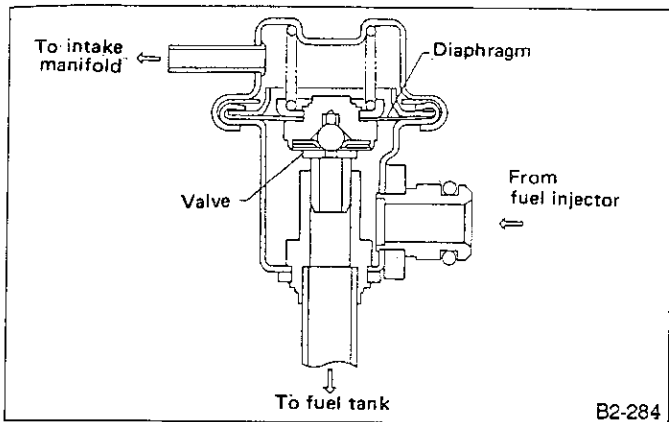


Fig. 6

3. FUEL INJECTOR

The MPFI system employs a gallery type (side-feed type) fuel injector.

The gallery type fuel injector is installed in the fuel pipe to allow cooling of the injector by the fuel.

The features of this type of fuel injector are as follows:

- 1) High heat resistance
- 2) Low driving noise
- 3) Easy to service
- 4) Small size

The fuel injector injects fuel according to the valve open signal received from the ECU.

The nozzle is attached on the top of the fuel injector. The needle valve is lifted by the solenoid coil through the plunger on arrival of the valve open signal.

Since the injection opening, the lifted level of valve and the regulator-controlled fuel pressure are kept constant, the amount of fuel to be injected can be controlled only by the valve open signal from the ECU.

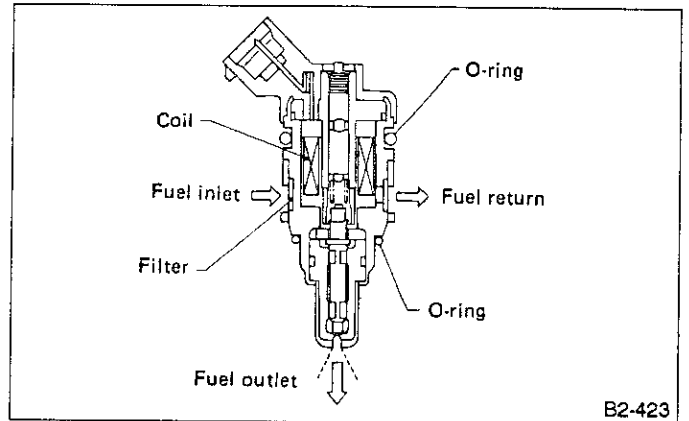


Fig. 7

4. Sensor and Switch

1. O₂ SENSOR (Catalyst model only)

The O₂ sensor is used to sense oxygen concentration in the exhaust gas. If the fuel ratio is leaner than the stoichiometric ratio in the mixture (i.e. excessive amount of air), the exhaust gas contains more oxygen. To the contrary, if the fuel ratio is richer than the stoichiometric ratio, the exhaust gas contains hardly any oxygen. Therefore, examination of the oxygen concentration in exhaust gas makes it possible to show whether the air/fuel ratio is leaner or richer than the stoichiometric ratio. The O₂ sensor has a zirconia tube (ceramic) which generates voltage if there is a difference in oxygen concentration between the inside and outside of the tube. Platinum is coated on the inside and outside of the zirconia tube for the purpose of catalysis and electrode provision. The hexagon screw on the outside is grounded to the exhaust pipe, and the inside is connected to the ECU through the harness.

A ceramic heater is employed to improve performance at low temperature.

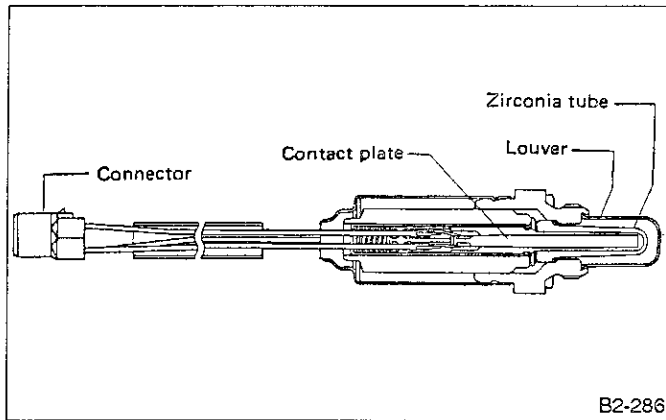


Fig. 8

When rich air-fuel mixture is burnt in the cylinder, the oxygen in the exhaust gases reacts almost completely through the catalytic action of the platinum coating on the surface of the zirconia tube. This results in a very large difference in the oxygen concentration between the inside and outside, and the electromotive force generated is large.

When a lean air-fuel mixture is burnt in the cylinder, oxygen remains in the exhaust gases even after the catalytic action, and this results in a small difference in the oxygen concentration. The electromotive force is very small.

The difference in oxygen concentration changes greatly in the vicinity of the optimum air-fuel ratio, and hence the change in the electromotive force is also large. By inputting this information into the MPFI control unit, the air-fuel ratio of the supplied mixture can be determined easily. The O₂ sensor does not generate much electromotive force when the temperature is low. The characteristics of the electromotive force stabilize at temperature of approximately 300 to 400°C (572 to 752°F).

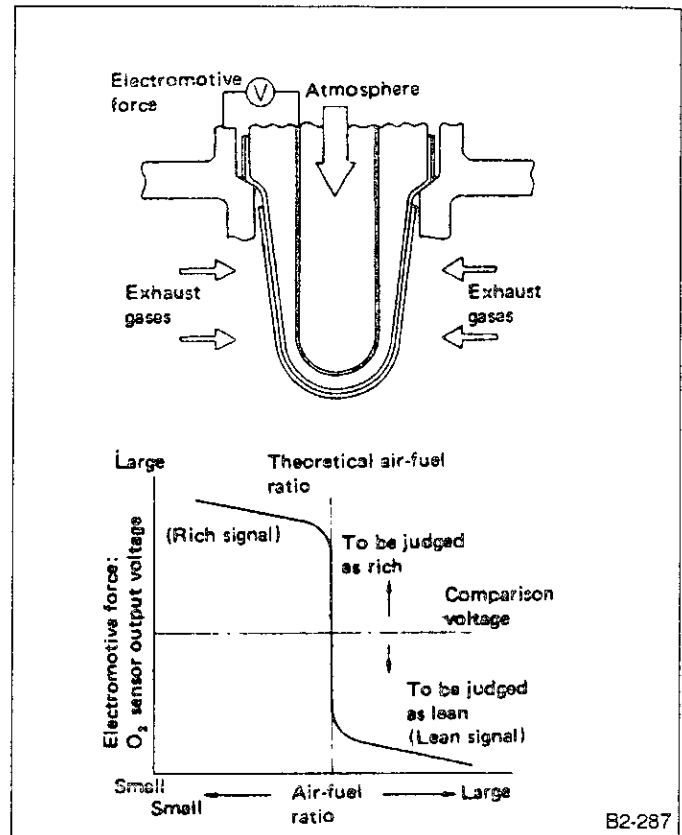


Fig. 9

2. WATER TEMPERATURE SENSOR

The water temperature sensor is located on the water pipe which is made of aluminum alloy. Its thermistor changes resistance with respect to temperature. A water temperature signal converted into resistance is transmitted to the ECU to control the amount of fuel injection, ignition timing, purge control solenoid valve, etc.

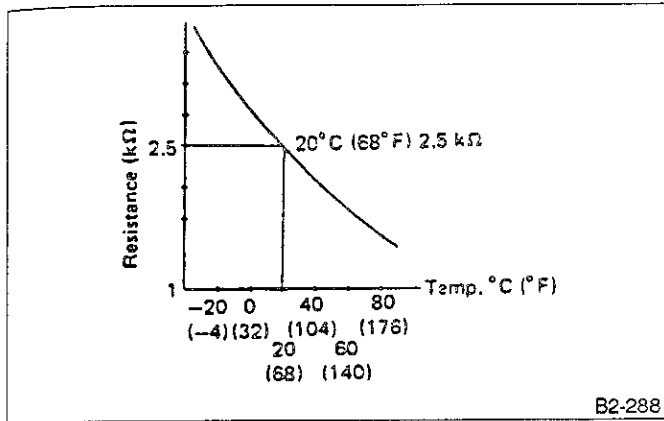


Fig. 10

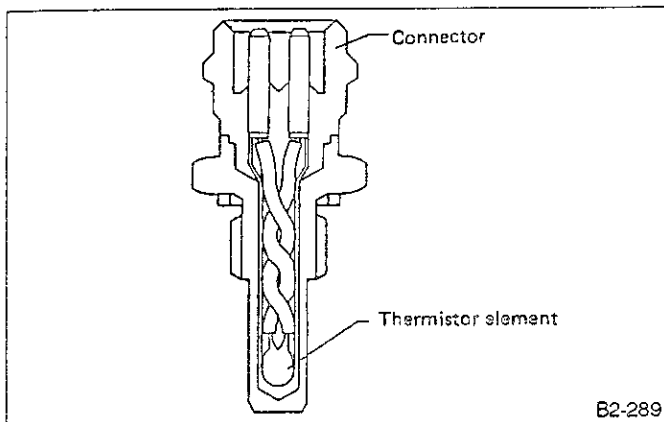


Fig. 11

3. KNOCK SENSOR

The knock sensor is installed on the cylinder block, and senses knocking signals from each cylinder. This knock sensor is a piezo-electric type which converts knocking vibrations into electric signals. It consists of a piezo-electric element, weight, and case. If knocking occurs in the engine, the weight in the case moves causing the piezo-electric element to generate a voltage.

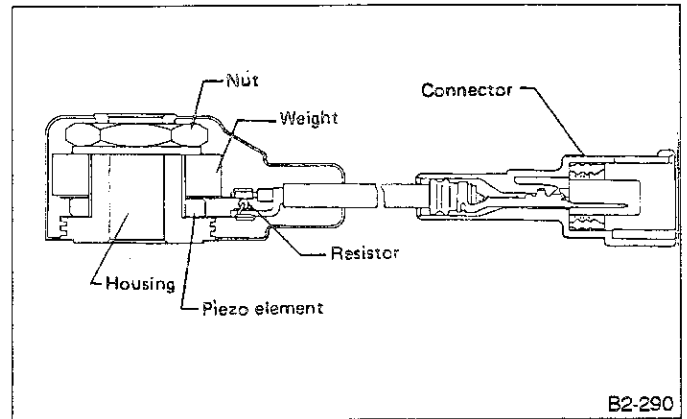


Fig. 12

4. CRANK ANGLE SENSOR

The crank angle sensor is installed on the oil pump, located in the front center portion of the cylinder block, to detect the crank angle position. It is designed so that the ECU accurately reads the number of pulses which occur when protrusions provided at the perimeter of the crank sprocket (rotating together with the crankshaft) cross the crank angle sensor.

The crank angle sensor is a molded type which consists of a magnet, pick-ups, coil, terminals, etc.

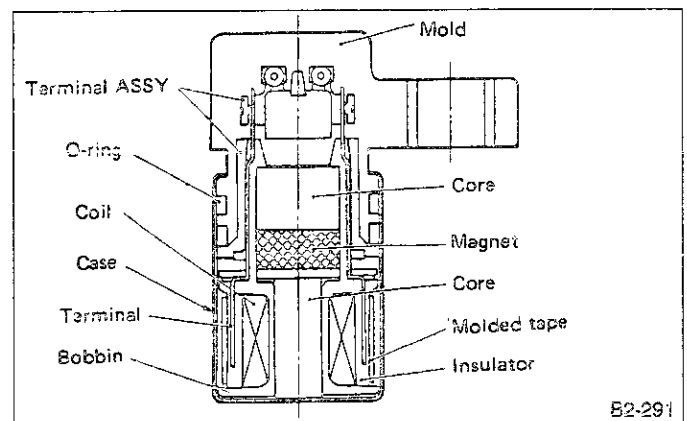


Fig. 13

Function

The crank sprocket is provided with six protrusions. Crank rotation causes these protrusions to cross the crank angle sensor so that magnetic fluxes in the coil change with the change in air gap between the sensor pickup and the sprocket. The change in air gap induces an electromotive force which is transmitted to the ECU.

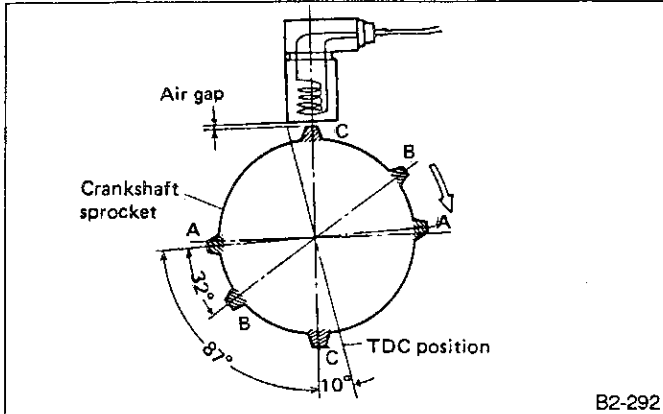


Fig. 14

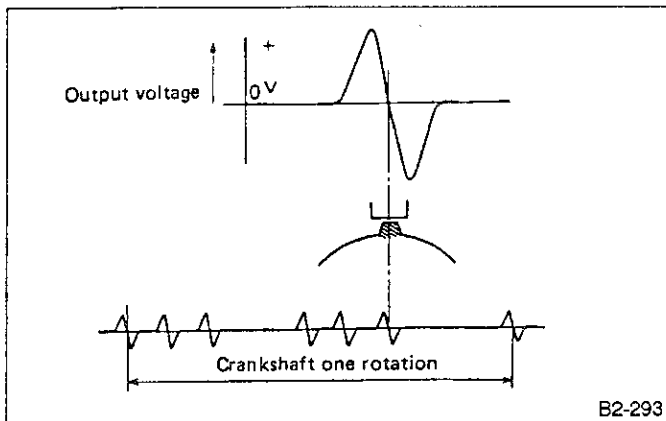


Fig. 15

5. CAM ANGLE SENSOR

The cam angle sensor is located on the left-hand camshaft support to detect the combustion cylinder at any one moment.

It is designed so that the ECU accurately reads the number of pulses which occur when protrusions provided on the back of the LH camshaft-drive sprocket cross the sensor.

Internal construction and the basic operating principle of the cam angle sensor are similar to those of the crank angle sensor. A total of seven protrusions (one each at two locations, two at one location and three at one location) are arranged in four equal parts of the sprocket, as shown below.

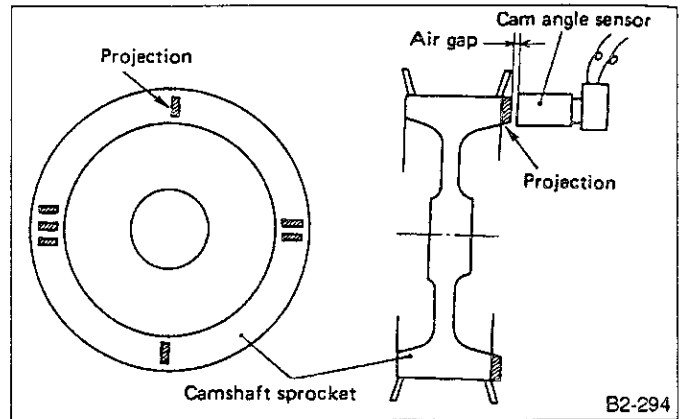


Fig. 16

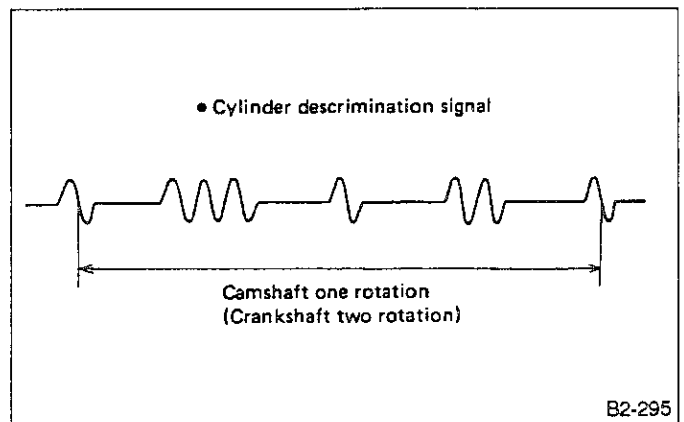


Fig. 17

6. VEHICLE SPEED SENSOR 2

The vehicle speed sensor 2 consists of a magnet rotor which is rotated by a speedometer cable and a reed switch. It is built into the combination meter. One rotation of the magnet rotor turns the reed switch on and off four times to produce a digital signal. The digital signal is used as a vehicle speed signal which is transmitted to the ECU.

7. ECONOMY SWITCH (AT model only)

With economy switch set to "ON", the shift pattern is set in the ECONOMY mode to improve fuel economy. The air-fuel mixture is then controlled to a relatively lean ratio range. This does not, however, sacrifice driveability, and allows the vehicle to respond suitably to varying conditions.

8. A/C (Air Conditioning) SWITCH AND RELAY

The A/C switch turns the A/C system on or off. The on-off operation of the switch is transmitted to the ECU. The A/C cut relay breaks the current flow to the compressor, through the use of an output signal from the ECU, for a certain period of time when a "full-

throttle" signal (emitted from the throttle sensor) enters the ECU while the compressor is operating. This prevents the degradation of acceleration performance and stabilizes driving performance. This cut relay is installed in the main fuse box located at the left side of the engine compartment.

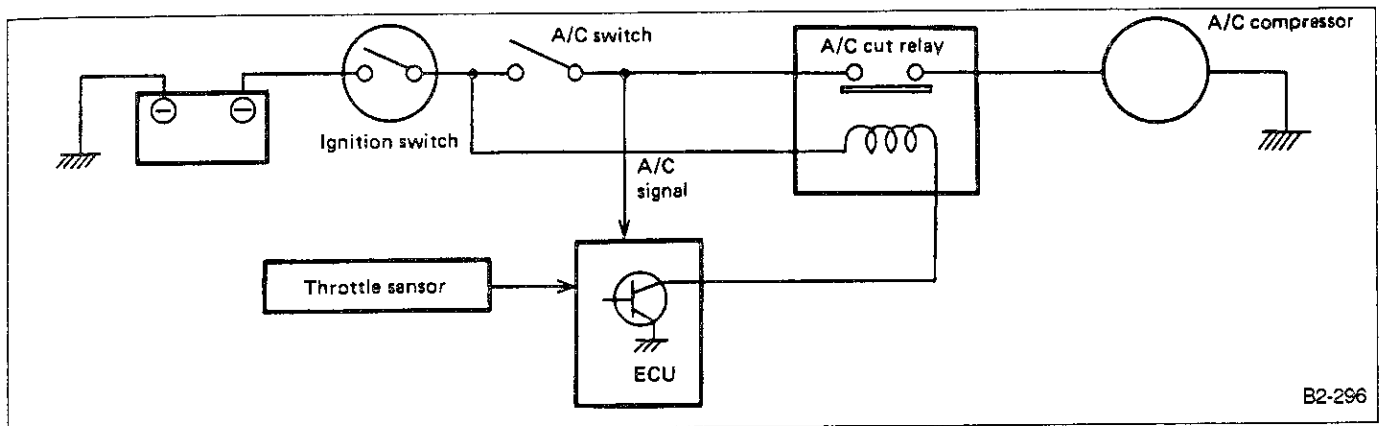


Fig. 18

B2-296

5. Control System

1. GENERAL

The ECU receives signals sent from various sensors and switches to judge the engine operating condition and emits output signals to provide the optimum control and/or functioning of various systems.

Major items governed by the ECU are as follow:

- Fuel injection control

- Ignition system control
- By-pass air control (Idle speed control)
- Canister purge control
- Radiator fan control
- Fuel pump control
- Air conditioner cut control
- Self-diagnosis function
- Fail-safe function

2. INPUT AND OUTPUT SIGNALS

	Unit	Function
Input signal	Air flow sensor	Detects the amount of intake air.
	Throttle sensor	Detects the throttle position.
	Idle switch	Detects a fully-closed throttle.
	*O ₂ sensor	Detects the density of O ₂ in exhaust gases.
	Crank angle sensor	Detects engine speed.
	Cam angle sensor	Detects the relative cylinder positions.
	Water temperature sensor	Detects the coolant temperature.
	**Knock sensor	Detects engine knocking.
	Vehicle speed sensor 2	Detects vehicle speed.
	Ignition switch	Detects ignition switch operation.
	Starter switch	Detects the condition of engine cranking
	Inhibitor switch (AT)	Detects shift positions.
	A/C switch	Detects the ON-OFF operation of the A/C switch.
	Economy switch (AT)	Detects the ON-OFF operation of the economy switch.
	Neutral switch (MT)	Detects gear shift lever neutral position.
***Idle mixture adjuster	Adjusts air-fuel ratio during idling to lower the CO content of the exhaust gas.	
Output signal	Fuel injector	Inject fuel.
	Ignition signal	Turns primary ignition current on or off.
	Fuel pump relay	Turns the fuel pump relay on or off.
	A/C control relay	Turns A/C control relay on or off.
	Radiator fan control relay	Turns radiator fan control relay on or off.
	By-pass air control solenoid valve	Adjusts the amount of by-pass air flowing through the throttle valve.
	Check engine light	Indicates trouble.
	Purge control solenoid valve	Controls the canister purge control solenoid valve.

*: Catalyst model only

** : 2200 cc model only

***: Non-catalyst model only

3. INPUT AND OUTPUT SIGNAL DIAGRAM

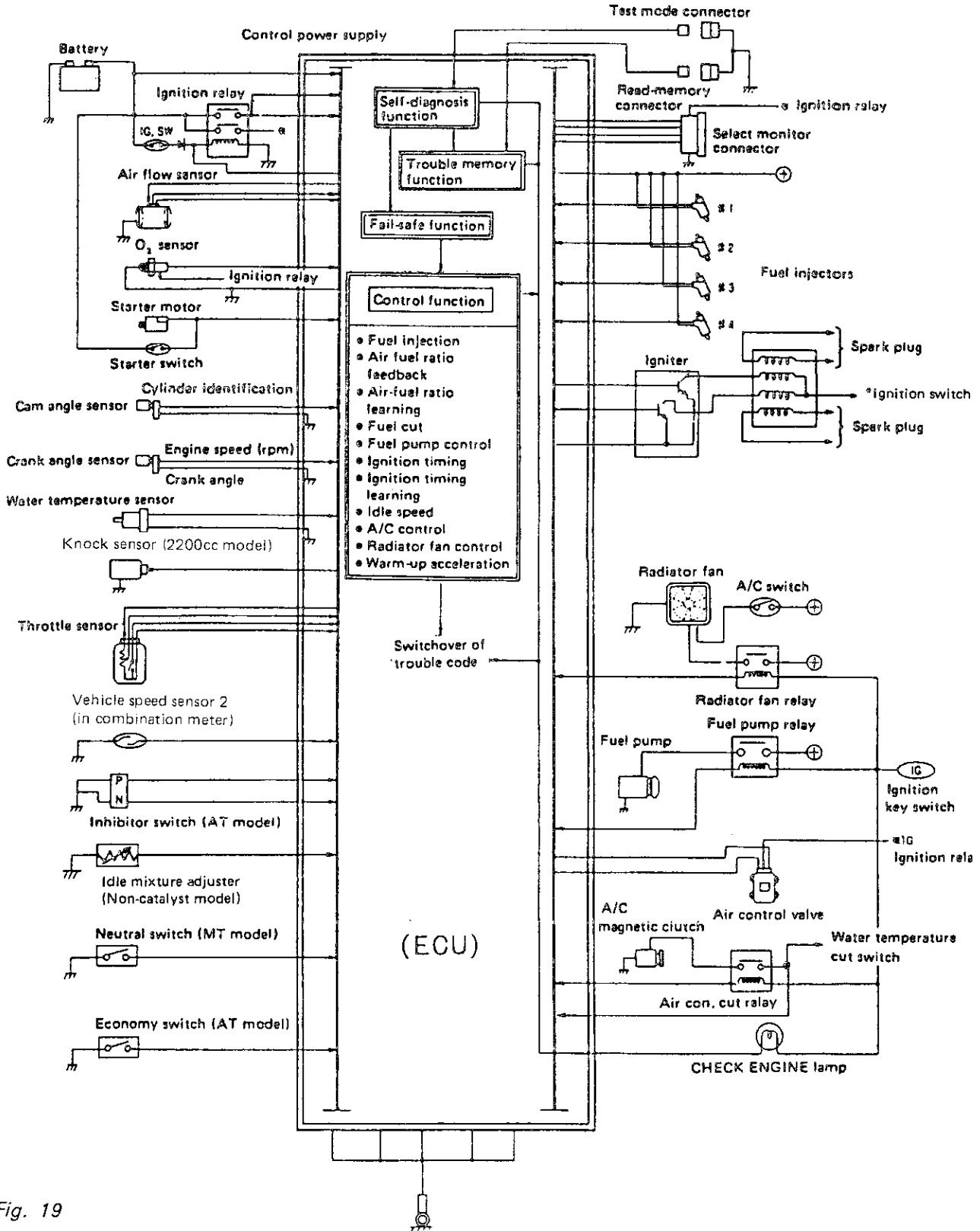


Fig. 19

B2-718

4. FUEL INJECTION CONTROL

The ECU receives signals emitted from various sensors to control the amount of fuel injected and the fuel injection timing. Sequential fuel injection control is utilized over the entire engine operating range except during standing starts.

The amount of fuel injected by the injector valve is dependent upon the length of time it remains open. The optimum fuel injection timing is determined by transmitting a signal to the injector from the ECU according to varying engine operations. Feedback control is also accomplished by means of a learning control. As a result, the fuel injection control system is highly responsive and accurate in design and structure.

The sequential fuel injection system is designed so that fuel is injected at a specific time to provide maximum air intake efficiency for each cylinder. In other words, fuel injection is completed just before the intake valve begins to open.

1) Fuel injection characteristics

Fuel injection timing is basically expressed as indicated below:

- (1) During engine starts:
 - Duration of fuel injection
 - = Duration of fuel injection during engine starts
- (2) During normal operation:
 - Basic duration of fuel injection x correction factor + voltage correction time
 - Basic duration of fuel injection The basic length of time fuel is injected. This is determined by two factors—the amount of intake air detected by the air flow sensor and the engine speed (rpm) monitored by the crank angle sensor.
 - Duration of fuel injection during engine starts Determined according to the engine coolant temperature detected by a signal emitted from the water temperature sensor to improve starting ability.
 - Voltage correction time Compensates for the fuel injector's time lag affected by the battery voltage.

2) Correction coefficients

Correction coefficients are used to correct the basic duration of fuel injection so that the air-fuel ratio meets the requirements of varying engine operations.

These correction coefficients are classified as follows:

(1) Air-fuel ratio coefficient:

Allotted to provide the optimum air-fuel ratio in relation to engine speed and the basic amount of fuel injected.

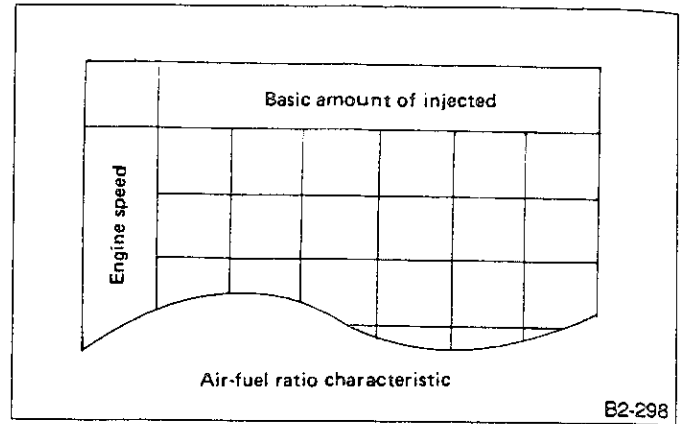


Fig. 20

- (2) Start increment coefficient:
 - Increases the amount of fuel injected only when cranking the engine, which improves starting ability.

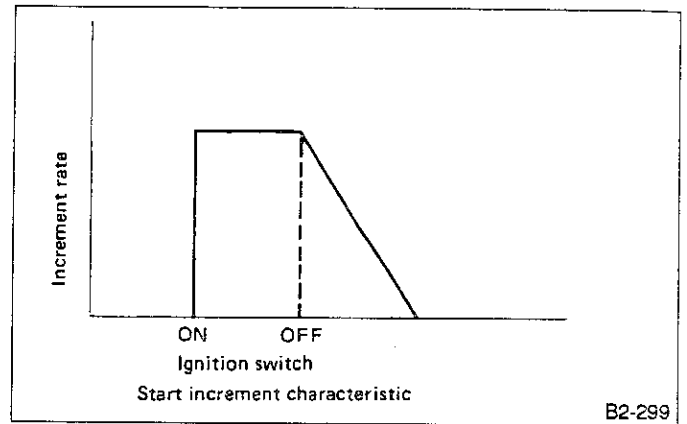


Fig. 21

- (3) Water temperature increment coefficient:
 - Used to increase the amount of fuel injected in relation to a signal emitted from the water temperature sensor for easier starting of a cold engine. The lower the water temperature, the greater the increment rate.

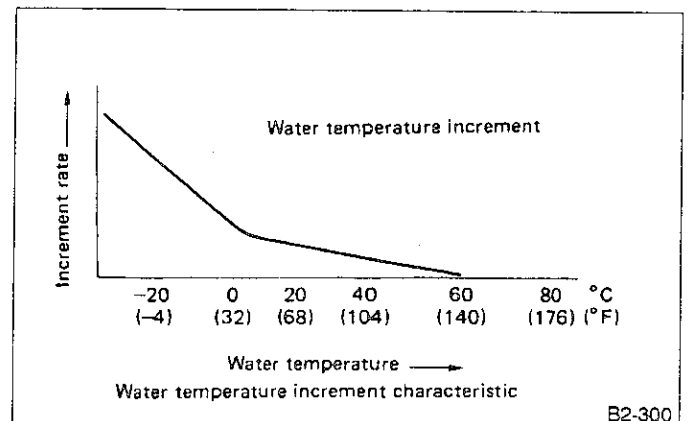


Fig. 22

(4) After-start increment coefficient:
Increases the amount of fuel injected for a certain period of time immediately after the engine starts to stabilize engine operation.

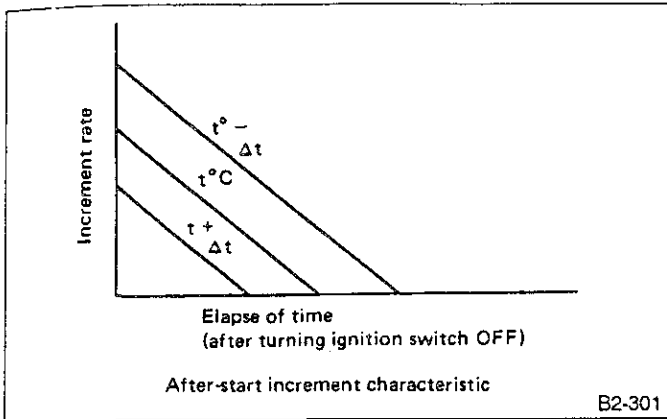


Fig. 23

(6) Acceleration increment coefficient:
Compensates for time lags of air flow measurement and/or fuel injection during acceleration to provide quick response.

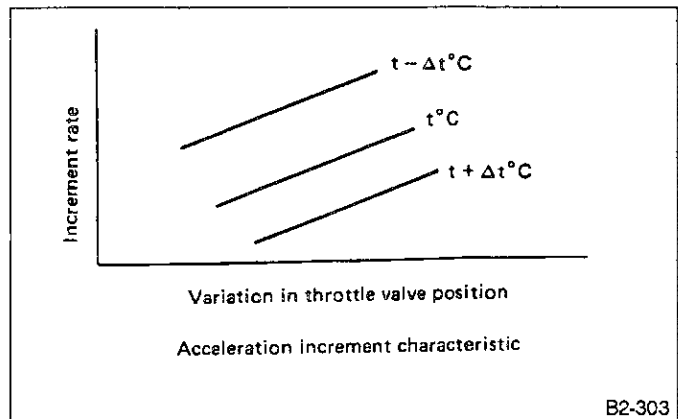


Fig. 25

(5) Full increment coefficient:
Increases the amount of fuel injected by a signal emitted from the throttle sensor in relation to a signal emitted from the air flow sensor.

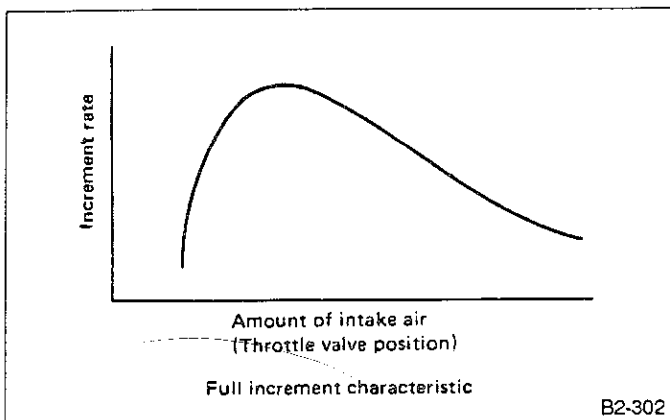


Fig. 24

3) Air-fuel ratio feedback coefficient "alpha" (Catalyst model only)

This feedback coefficient utilizes the O₂ sensor's electromotive force (voltage) as a signal to be entered into the ECU. When low voltage is entered, the ECU judges it as a lean mixture, and when high voltage is entered, it is judged as a rich mixture. In other words, when the air-fuel ratio is richer than the stoichiometric mixture

ratio, the amount of fuel injected is decreased. When it is leaner, the amount of fuel injected is increased. In this way, the air-fuel ratio is compensated so that it comes as close to the stoichiometric mixture ratio as possible on which the three-way catalyst acts most effectively. (CO, HC and NO_x are also reduced when the air-fuel ratio is close to stoichiometric mixture ratio.)

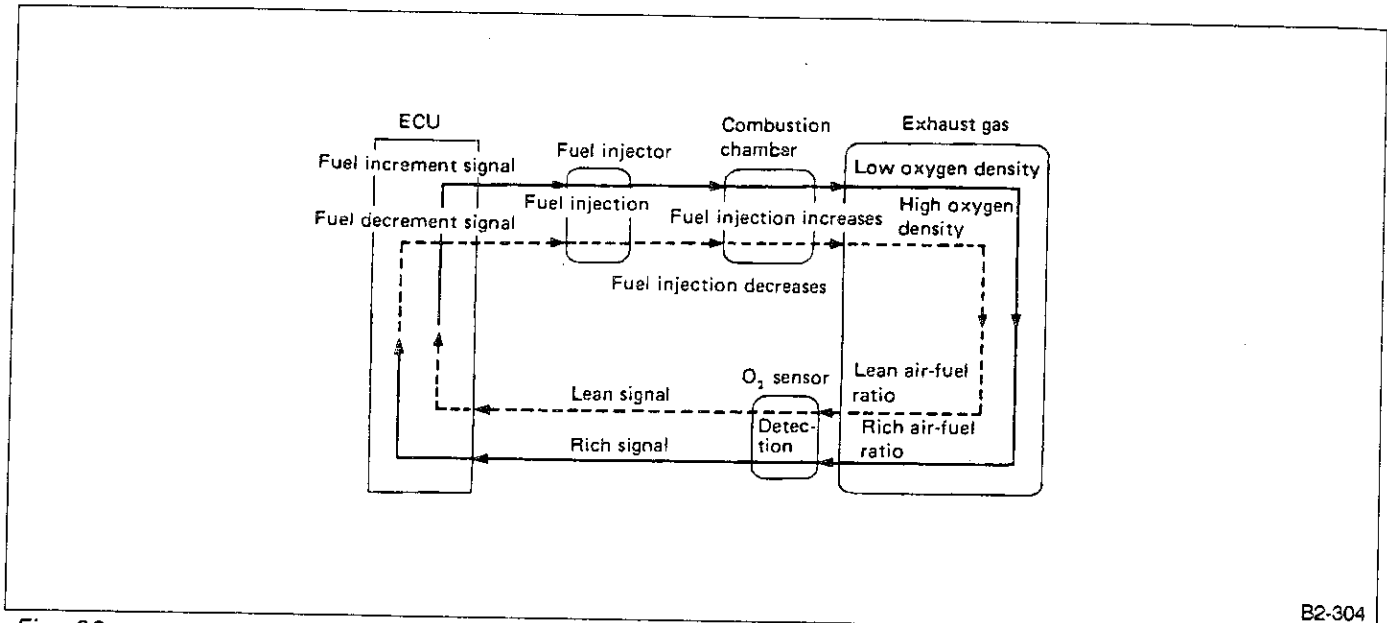


Fig. 26

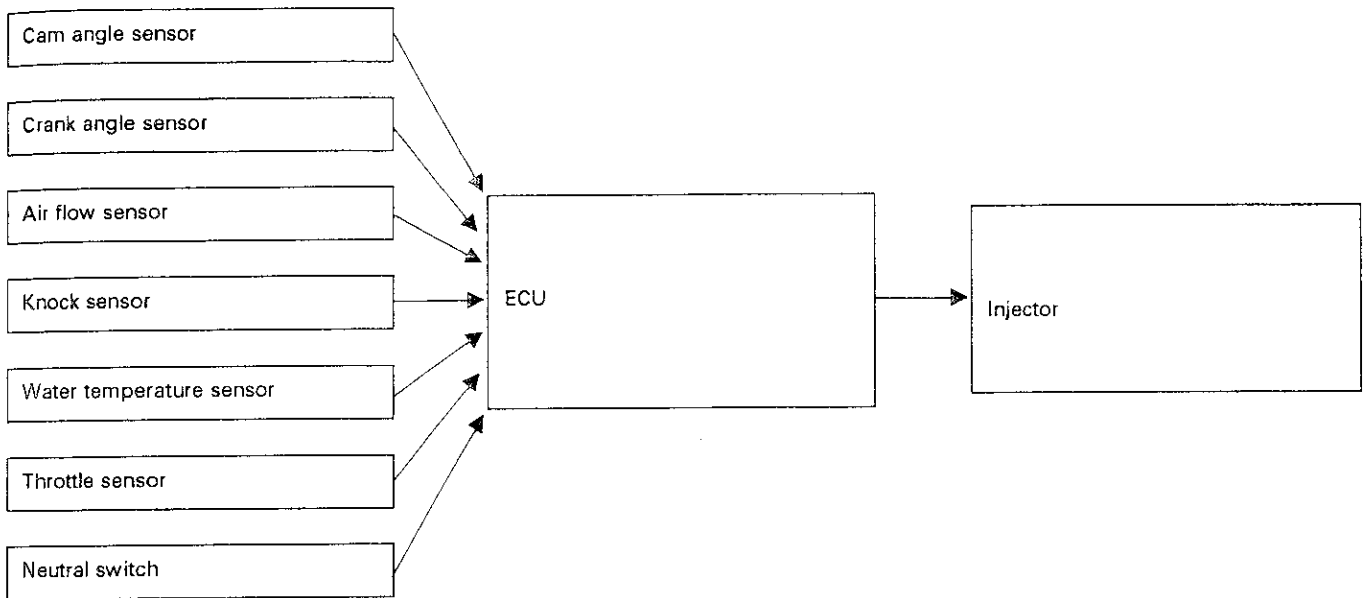
B2-304

4) Learning control system (Catalyst model only)

In a conventional air-fuel feedback control system, the basic amount of fuel injected (according to engine speed and various loads) is stored in the memory. After the ECU receives a signal emitted from the O₂ sensor, the basic amount of fuel injected is corrected so that it is close to the stoichiometric mixture ratio. This means that the greater the air-fuel ratio is corrected, the lesser the control accuracy.

In SUBARU engines, however, an air-fuel ratio learning control system constantly memorizes the amount of

correction required in relation to the basic amount of fuel to be injected (the basic amount of fuel injected is determined after several cycles of fuel injection), so that the correction affected by feedback control is minimized. Thus, quick response and accurate control of variations in air-fuel ratio, sensors' and actuators' characteristics during operation, as well as in the air-fuel ratio with the time of engine operation, are achieved. In addition, accurate control contributes much to stability of exhaust gases and driving performance.



5. IGNITION SYSTEM CONTROL

The ECU receives signals emitted from the air flow sensor, water temperature sensor, crank angle sensor, cam angle sensor, knock sensor, etc., to judge the operating condition of the engine. It then selects the optimum ignition timing stored in the memory and immediately transmits a primary current OFF signal to the igniter to control the ignition timing.

While the ECU receives signals emitted from the knock sensor, it is controlled so that advanced ignition timing is maintained immediately before engine knock occurs. This system control type features a quick-to-response learning control method by which data stored in the ECU memory is processed in comparison with information emitted from various sensors and switches.

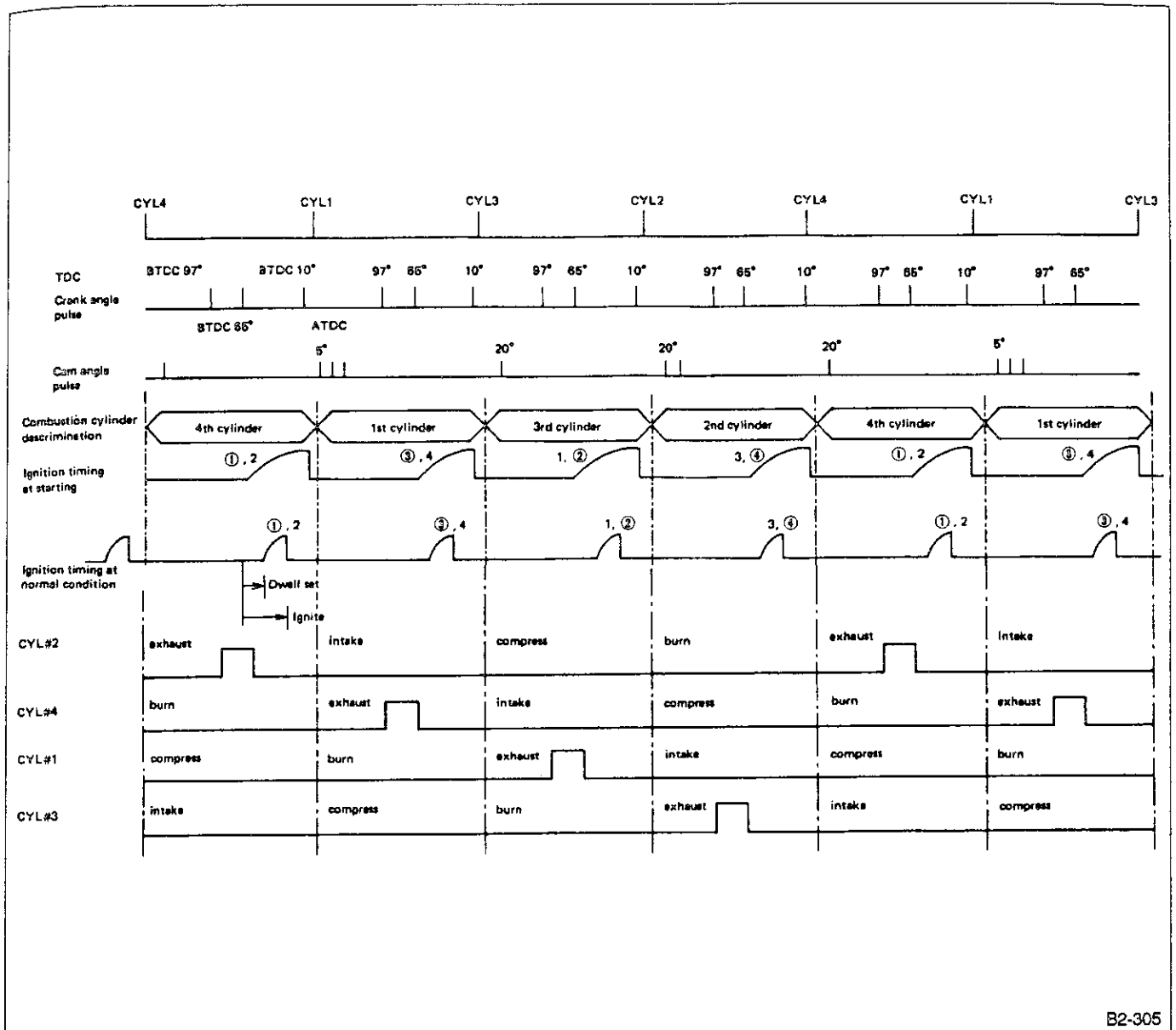
Thus, the ECU constantly provides the optimum ignition timing in relation to output, fuel consumption, exhaust gas, etc., according to various engine operating conditions, the octane rating of the fuel used, etc.

Two ignition coils are used - one for the #1 and #2 cylinders, and one for the #3 and #4 cylinders. A simultaneous ignition type is employed for #1 and #2 cylinders on one hand, and #3 and #4 cylinders on the other.

This eliminates the distributor and achieves maintenance-free operation.

- Ignition control under normal engine conditions
Between the 97° signal and the 65° signal, the ECU measures the engine revolutions, and by using this data it decides the dwell set timing and ignition timing according to the engine condition.

- Ignition control under starting conditions
Engine revolutions fluctuate at the starting condition, so the ECU cannot control the ignition timing. When such a condition exists, ignition timing is fixed at 10° BTDC by using the 10° signal.



B2-305

Fig. 27

6. BY-PASS AIR CONTROL (IDLE SPEED CONTROL)

The ECU activates the by-pass air control solenoid valve in advance to control the amount of by-pass air flowing through the throttle valve in relation to signals emitted from the crank angle sensor, cam angle sensor, water temperature sensor and A/C switch, so that the proper idle speed specified for each engine load is achieved.

The by-pass air control solenoid valve utilizes a duty solenoid design so that the amount of valve "lift" is determined by a certain operating frequency. For this reason, the by-pass air flow is regulated by controlling

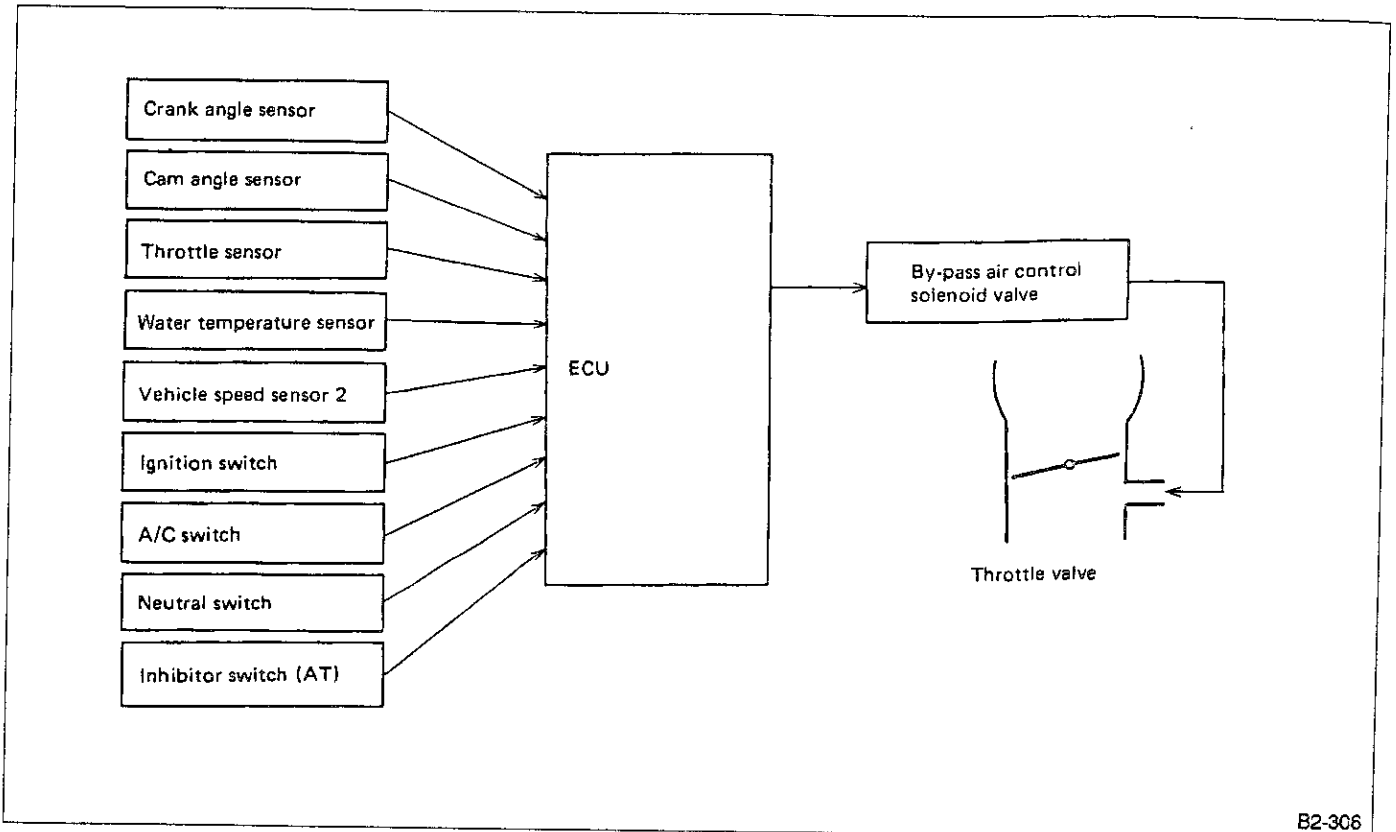
the duty ratio. The relationship between the duty ratio, valve lift and by-pass air flow is as follows:

Duty ratio (high) → Increases valve lift and by-pass air flow.

Bypass air control features the following advantages:

1. Compensation for engine speed under A/C (air conditioning) system and electrical loads.
2. Increase in idle speed during early stage of warm-up period.
3. A dashpot function during the time the throttle valve is quickly closed.
4. Prevention of engine speed variations over time.

Diagram



B2-306

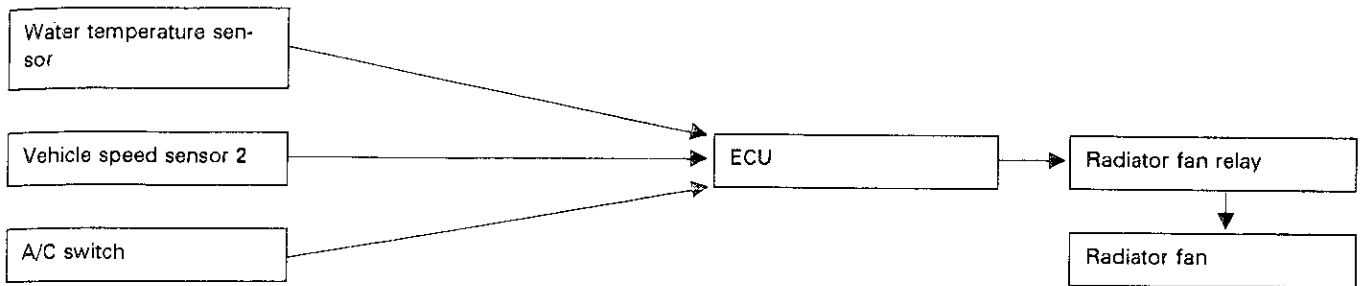
Fig. 28

7. CANISTER PURGE CONTROL

The ECU receives signals emitted from the water temperature sensor, vehicle speed sensor 2 and crank angle sensor to control the purge control solenoid. Canister purge takes place during operation of the vehicle except under certain conditions (during idle, etc.). The purge line is connected to the throttle chamber to purge fuel evaporation gas from the canister according to the amount of intake air.

8. RADIATOR FAN CONTROL

The ON-OFF control of the radiator fan (for models which are not equipped with an air conditioning system) is governed by the ECU which receives signals sent from the water temperature sensor and vehicle speed sensor 2. On models which are equipped with an air conditioning system, the ECU receives signals sent from the water temperature sensor, vehicle speed sensor 2 and A/C switch. These signals simultaneously turn ON or OFF the main radiator fan and A/C subfan as well as setting them at "HI" or "LO" speed.



9. FUEL PUMP CONTROL

The ECU receives a signal emitted from the crank angle sensor and turns the fuel pump relay ON or OFF to

control fuel pump operation. To improve safety, the fuel pump will stop if the engine stalls with the ignition switch ON.

Ignition switch ON	Fuel pump relay	Fuel pump
A certain period of time (after ignition switch is turned ON)	ON	Operates
While cranking the engine	ON	Operates
While engine is operating	ON	Operates
When engine stops	OFF	Does not operate



10. A/C CUT CONTROL

When the ECU receives a "full-open" signal emitted from the throttle sensor while the air conditioning system is operating, the A/C cut relay turns off for a certain

period of time to stop the compressor. This prevents degradation of output during acceleration and stabilizes driveability.

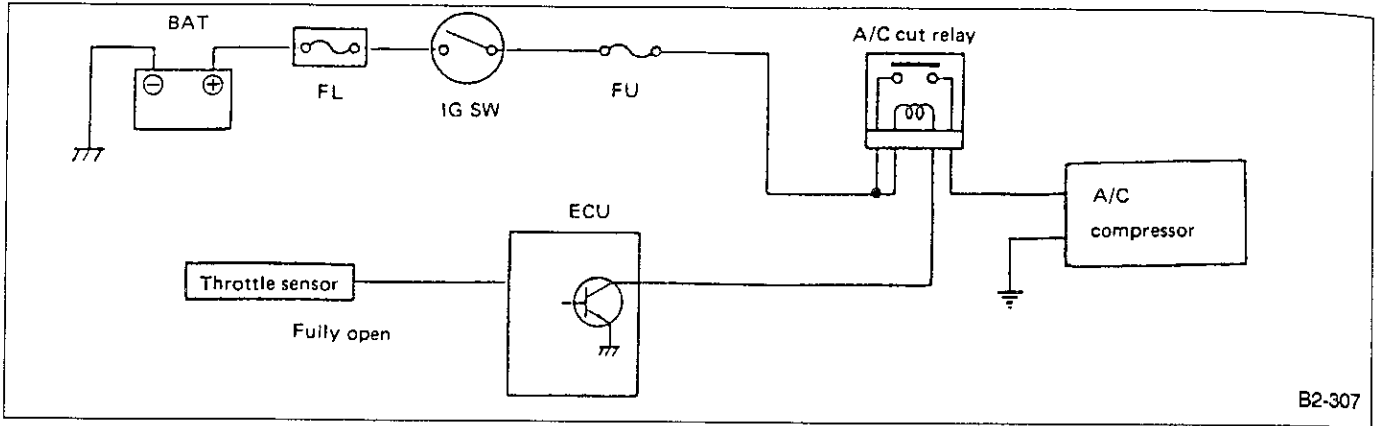


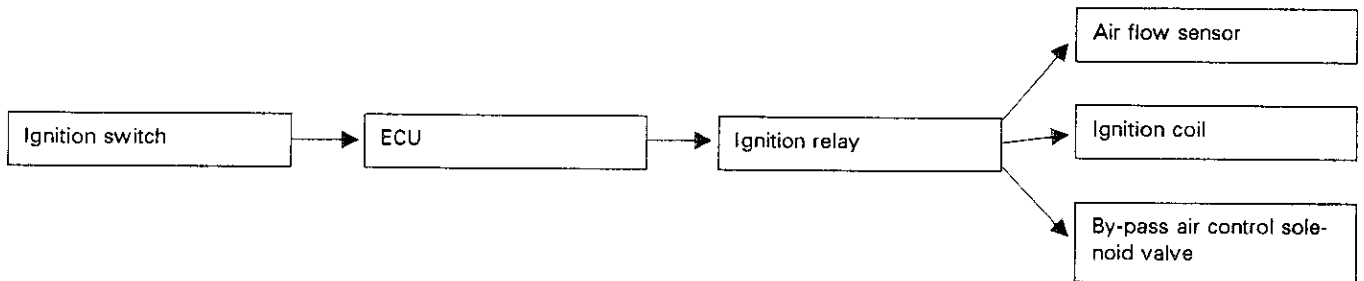
Fig. 29

B2-307

11. POWER SUPPLY CONTROL

When the ECU receives an ON signal emitted from the ignition switch, current flows through the ignition relay. This turns the ignition relay ON so that power is supplied to the ignition coil, air flow sensor, by-pass air control solenoid valve, etc.

Power to the above parts except the fuel injectors is turned off five seconds after the ECU receives an OFF signal from the ignition switch. The fuel injectors stop fuel injection immediately after the ignition switch is turned OFF because the injection signal is cut off.



6. Self-diagnosis System

1. GENERAL

The self-diagnosis system detects and indicates a fault in various inputs and outputs of the complex electronic control. The warning light (CHECK ENGINE light) on the instrument panel indicates occurrence of a fault or trouble, and also indicates a trouble code.

Further, against such a failure or sensors as may disable the drive, the fail-safe function is provided to ensure the minimal driveability.

2. FUNCTION OF SELF-DIAGNOSIS

The self-diagnosis function has four modes: U-check mode, Read memory mode, D-check mode and Clear memory mode. Two connectors (Read memory and Test mode) and a light (CHECK ENGINE light) are used. The connectors are for mode selection and the light monitors the type of problem.

- Relationship between modes and connectors

Mode	Engine	Read memory connector	Test mode connector
U-check	Ignition ON	DISCONNECT	DISCONNECT
Read memory	Ignition ON	CONNECT	DISCONNECT
D-check	Ignition ON (Engine ON)	DISCONNECT	CONNECT
Clear memory	Ignition ON (Engine ON)	CONNECT	CONNECT

- U-check mode

The U-check is a user-oriented mode in which only the MPFI components necessary for start-up and drive are diagnosed. On occurrence of a fault, the warning light (CHECK ENGINE light) is lighted to indicate to the user that the dealer's inspection is necessary. The diagnosis of other parts which do not give significant adverse effect to start-up and drive are excluded from this mode in order to avoid unnecessary uneasiness to be taken by the user.

- Read memory mode

This mode is used by the dealer to read past problems (even when the vehicle's monitor lights are off). It is most effective in detecting poor contact or loose connections of connectors, harnesses, etc.

- D-check mode

This mode is used by the dealer to check the entire MPFI system and detect faulty parts.

- Clear memory mode

This mode is used by the dealer to clear the trouble code from the memory after the affected part is repaired.

3. BASIC OPERATION OF SELF-DIAGNOSIS SYSTEM

● NO TROUBLE

Mode	Read memory connector	Test mode connector	Condition	CHECK ENGINE light
U-check	x	x	Ignition switch ON (Engine OFF)	ON
			Engine ON	OFF
Read memory	○	x	Ignition switch ON (Engine OFF)	Blink
			Engine ON	
D-check	x	○	Ignition switch ON (Engine OFF)	ON
			Engine ON	OFF → Blink*
Clear memory	○	○	Ignition switch ON (Engine OFF)	ON
			Engine ON	OFF → Blink

● TROUBLE

Mode	Read memory connector	Test mode connector	Condition	CHECK ENGINE light
U-check	x	x	Ignition switch ON	ON
Read memory	○	x	Ignition switch ON (Engine OFF)	Trouble code (Memory)
			Engine ON	ON
D-check	x	○	Engine ON	Trouble code**
Clear memory	○	○	Engine ON	Trouble code**

* When the engine operates at a speed greater than 2,000 rpm for more than 40 seconds, the check engine light blinks. However, when all check items check out "O.K.", even before the 40 seconds is reached, the check engine light blinks.

** When the engine operates at a speed greater than 2,000 rpm for more than 40 seconds, a trouble code is emitted.

4. FAIL-SAFE FUNCTION

For the part which has been judged faulty in the self-diagnosis, the ECU generates the associated pseudo

signal (only when convertible to electric signal) and carries out the computational processing. In this fashion, the fail-safe function is performed.

5. TROUBLE CODES AND FAIL-SAFE OPERATION

Trouble code	Item	Contents of diagnosis	Fail-safe operation
11	Crank angle sensor	No signal entered from crank angle sensor, but signal (corresponding to at least one rotation of crank) entered from cam angle sensor.	---
12	Starter switch	Abnormal signal emitted from ignition switch.	Turns starter switch signal OFF.
13	Cam angle sensor	No signal entered from cam angle sensor, but signal (corresponding to at least two rotations of cam) entered from crank angle sensor.	---
14	Injector #1	Fuel injector inoperative. (Abnormal signal emitted from monitor circuit.)	---
15	Injector #2		---
16	Injector #3		---
17	Injector #4		---
21	Water temperature sensor	Abnormal signal emitted from water temperature sensor.	Adjusts water to a specific temperature. Maintains radiator fan "ON" to prevent overheating.
22	Knock sensor*	Abnormal voltage produced in knock sensor monitor circuit.	Sets in regular fuel map and retards ignition timing by 5°.
23	Air flow sensor	Abnormal voltage input entered from air flow sensor.	Controls the amount of fuel (injected) in relation to engine speed and throttle sensor position.
24	By-pass air control solenoid valve	Solenoid valve inoperative. (Abnormal signal produced in monitor circuit.)	Prevents abnormal engine speed using "fuel cut" in relation to engine speed, vehicle speed and throttle sensor position.
31	Throttle sensor	Abnormal voltage input entered from throttle sensor.	Sets throttle sensor's voltage output to a fixed value.
32	O ₂ sensor**	O ₂ sensor inoperative.	---
33	Vehicle speed sensor 2	Abnormal voltage input entered from vehicle speed sensor.	Sets vehicle speed signal to a fixed value.
35	Purge control solenoid valve	Solenoid valve inoperative.	---
41	A/F learning control**	Faulty learning control function.	---
42	Idle switch	Abnormal voltage input entered from idle switch.	Judges OFF operation.
47	Economy switch (AT)	Abnormal signal entered from economy switch.	---
49	Air flow sensor	Use of improper air flow sensor.	---
51	Neutral switch (MT)	Abnormal signal entered from neutral switch.	---
51	Inhibitor switch (AT)	Abnormal signal entered from inhibitor switch.	---
52	Parking switch (AT)	Abnormal signal entered from parking switch.	---

*: 2200 cc model only

** : Catalyst model only

T TROUBLESHOOTING

1. Precautions

- 1) Never connect the battery in reverse polarity.
 - o The MPFI control unit will be destroyed instantly.
 - o The fuel injector and other part will be damaged in just a few minutes more.
- 2) Do not disconnect the battery terminals while the engine is running.
 - o A large counter electromotive force will be generated in the alternator, and this voltage may damage electronic parts such as ECU (MPFI control unit), etc.
- 3) Before disconnecting the connectors of each sensor and the ECU, be sure the turn off the ignition switch.
 - o Otherwise, the ECU may be damaged.
- 4) The connectors to each sensor in the engine compartment and the harness connectors on the engine side and body side are all designed to be waterproof. However, it is still necessary to take care not to allow water to get into the connectors when washing the vehicle, or when servicing the vehicle on a rainy day.
- 5) Every MPFI-related part is a precision part. Do not drop them.
- 6) Observe the following cautions when installing a radio in MPFI equipped models.
 - a. The antenna must be kept as far apart as possible from the control unit.
(The ECU is located under the steering column, inside of the instrument panel lower trim panel.)
 - b. The antenna feeder must be placed as far apart as possible from the ECU and MPFI harness.
 - c. Carefully adjust the antenna for correct matching.
 - d. When mounting a large power type radio, pay special attention to items a. thru c. above.
 - Incorrect installation of the radio may affect the operation of the ECU.
- 7) Before disconnecting the fuel hose, disconnect the fuel pump connector and crank the engine for more than five seconds to release pressure in the fuel system. If engine starts during this operation, run it until it stops.

2. Pre-inspection

Before troubleshooting, check the following items which might affect engine problems:

1. POWER SUPPLY

- 1) Measure battery voltage and specific gravity of electrolyte.

Standard voltage: 12 V

Specific gravity: Above 1.260

- 2) Check the condition of the main and other fuses, and harnesses and connectors. Also check for proper grounding.

2. CAPS AND PLUGS

- 1) Check that the fuel cap is properly closed.
- 2) Check that the oil filler cap is properly closed.
- 3) Check that the oil level gauge is properly inserted.

3. INTAKE MANIFOLD VACUUM PRESSURE

- 1) After warming up the engine, measure intake manifold vacuum pressure while at idle.

Standard vacuum pressure:

Approx. - 66.7 kPa (- 500 mmHg, - 19.69 inHg).

- 2) Unusual vacuum pressure occurs because of air leaks, fuel or engine problems. In such a case, engine idles roughly.

4. FUEL PRESSURE

- 1) Fuel pressure elimination
 - (1) Disconnect the fuel pump connector.
 - (2) Start the engine.
 - (3) Leave the engine until it stalls.
 - (4) After it stalls, crank the starter for approximately 5 seconds and turn the ignition switch to "OFF."
- 2) Fuel pressure gauge installation
 - (1) Connect a fuel pressure gauge between the fuel strainer and the fuel hose.
 - (2) Connect the fuel pump connector.
- 3) Fuel pressure measurement
 - (1) Start the engine. Measure fuel pressure while allowing the engine to idle.

Fuel pressure:

177 - 206 kPa (1.8 - 2.1 kg/cm², 26 - 30 psi)

- (2) Race the engine to ensure that fuel pressure increases.

- (3) Stop the engine and connect the D-check connector. Turn the ignition switch to "ON" (engine "OFF") and measure fuel pressure.

Fuel pressure:

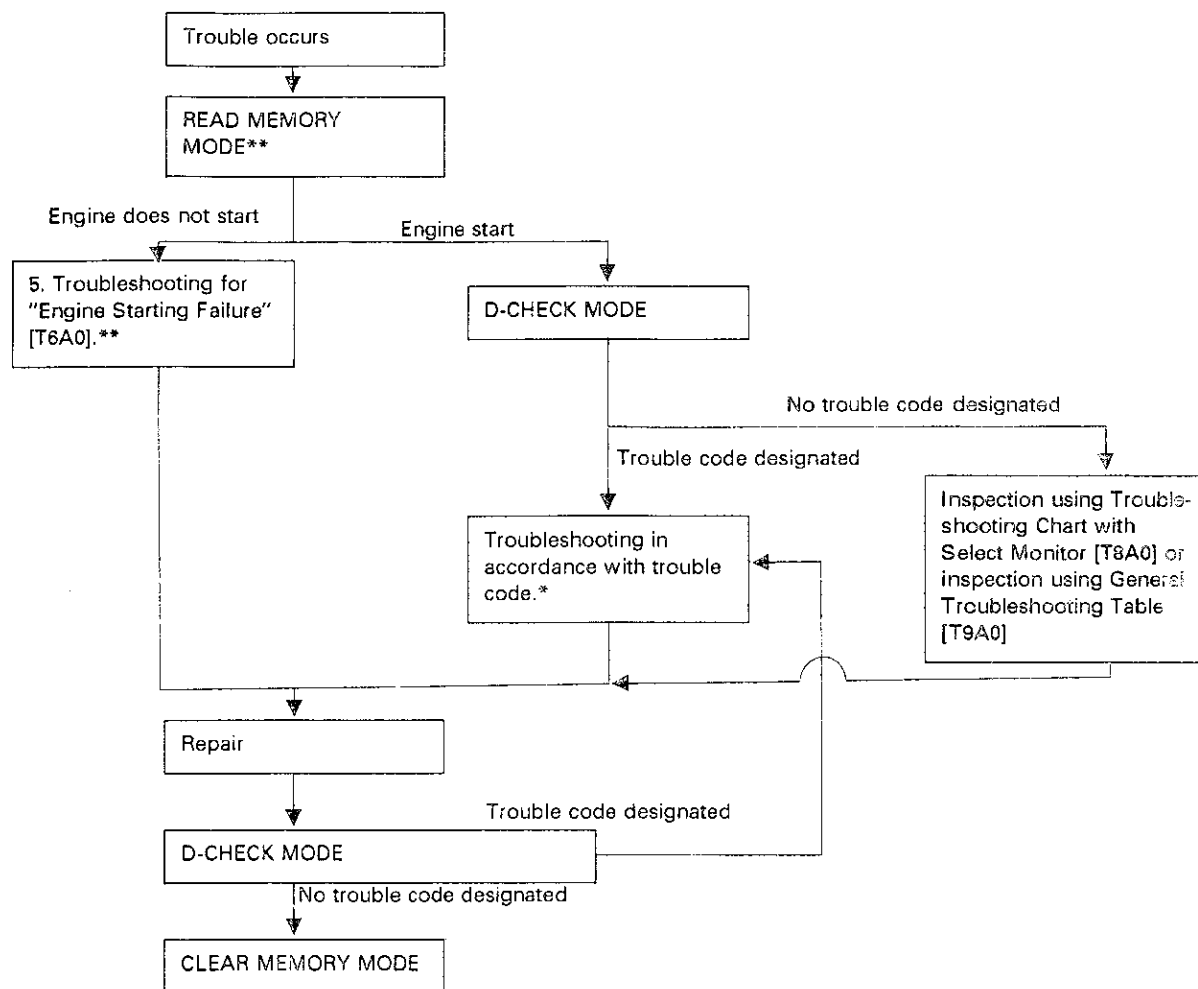
235 - 265 kPa (2.4 - 2.7 kg/cm², 34 - 38 psi)

5. ENGINE GROUNDING

Make sure the engine grounding terminal is properly connected to the engine.

3. Troubleshooting Chart for Self-diagnosis System

A: BASIC TROUBLESHOOTING PROCEDURE



*: When more than one trouble code is outputted, begin troubleshooting with the smallest trouble code number and proceed to the next higher code.

After correcting each problem, conduct the D-check and ensure that the corresponding trouble code no longer appears.

** : When a trouble code is displayed in the read-memory mode, conduct troubleshooting measures which correspond with the code.

a. Check the connector while it is connected unless specified otherwise.

b. Be sure to check again from the beginning in order to prevent secondary trouble caused by repair work.

c. When checking with the vacuum hose disconnected from the vacuum switch at engine ON, be sure to plug the hose.

B: LIST OF TROUBLE CODE

1. TROUBLE CODE

Trouble code	Item	Content of diagnosis
11.	Crank angle sensor	No signal entered from crank angle sensor, but signal entered from cam angle sensor.
12.	Starter switch	Abnormal signal emitted from ignition switch.
13.	Cam angle sensor	No signal entered from cam angle sensor, but signal entered from crank angle sensor.
14.	Injector #1	Fuel injector inoperative. (Abnormal signal emitted from monitor circuit.)
15.	Injector #2	
16.	Injector #3	
17.	Injector #4	
21.	Water temperature sensor	Abnormal signal emitted from water temperature sensor.
**22.	Knock sensor	Abnormal voltage produced in knock sensor monitor circuit.
23.	Air flow sensor	Abnormal voltage input entered from air flow sensor.
24.	By-pass air control solenoid valve	Solenoid valve inoperative. (Abnormal signal emitted from monitor circuit.)
31.	Throttle sensor	Abnormal voltage input entered from throttle sensor.
*32.	O ₂ sensor	O ₂ sensor inoperative.
33.	Vehicle speed sensor 2	Abnormal voltage input entered from speed sensor.
35.	Purge control solenoid valve	Solenoid valve inoperative.
*41.	AF (Air/fuel) learning control	Faulty learning control function.
42.	Idle switch	Abnormal voltage input entered from idle switch.
47.	Economy switch (AT)	Abnormal signal entered from economy switch.
49.	Air flow sensor	Use of improper air flow sensor.
51.	Neutral switch (MT)	Abnormal signal entered from neutral switch.
51.	Inhibitor switch (AT)	Abnormal signal entered from inhibitor switch.
52.	Parking switch (AT)	Abnormal signal entered from parking switch.

*: Catalyst model only

**: 2200 cc model only

2. HOW TO READ TROUBLE CODE (FLASHING)

The CHECK ENGINE light flashes the code corresponding to the faulty part.

The long segment (1.2 sec on) indicates a "ten", and the short segment (0.2 sec on) signifies "one".

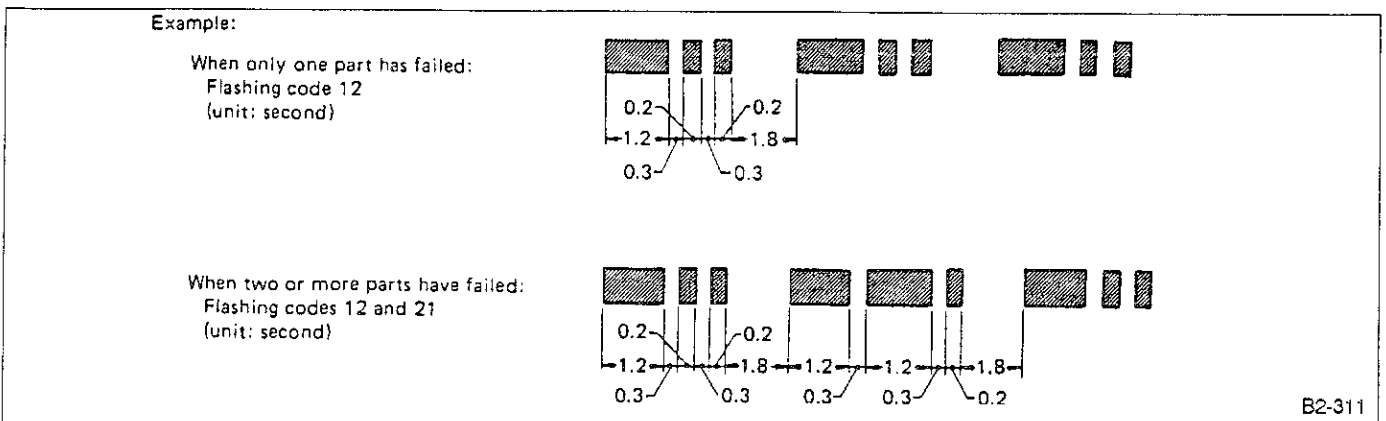
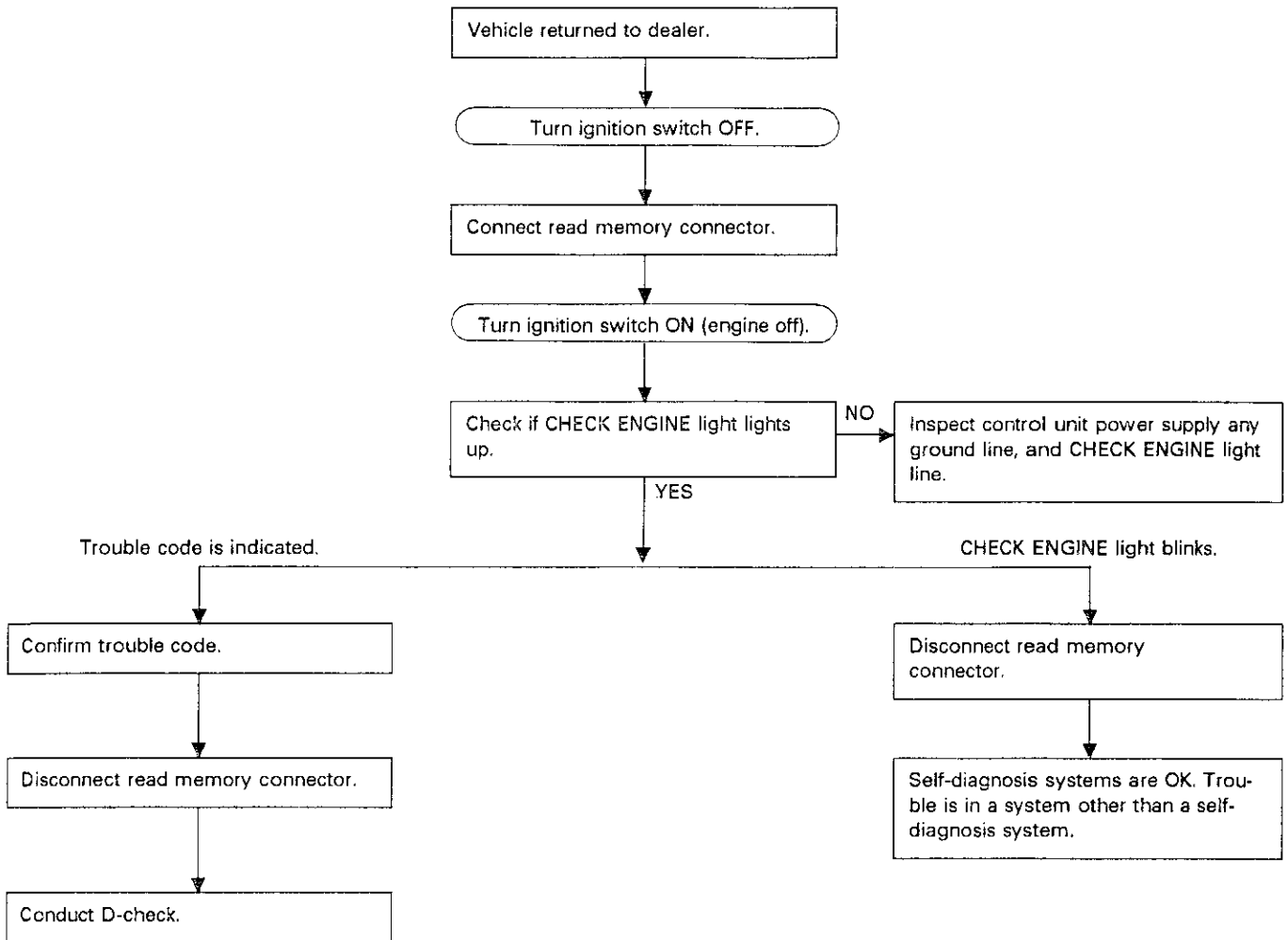
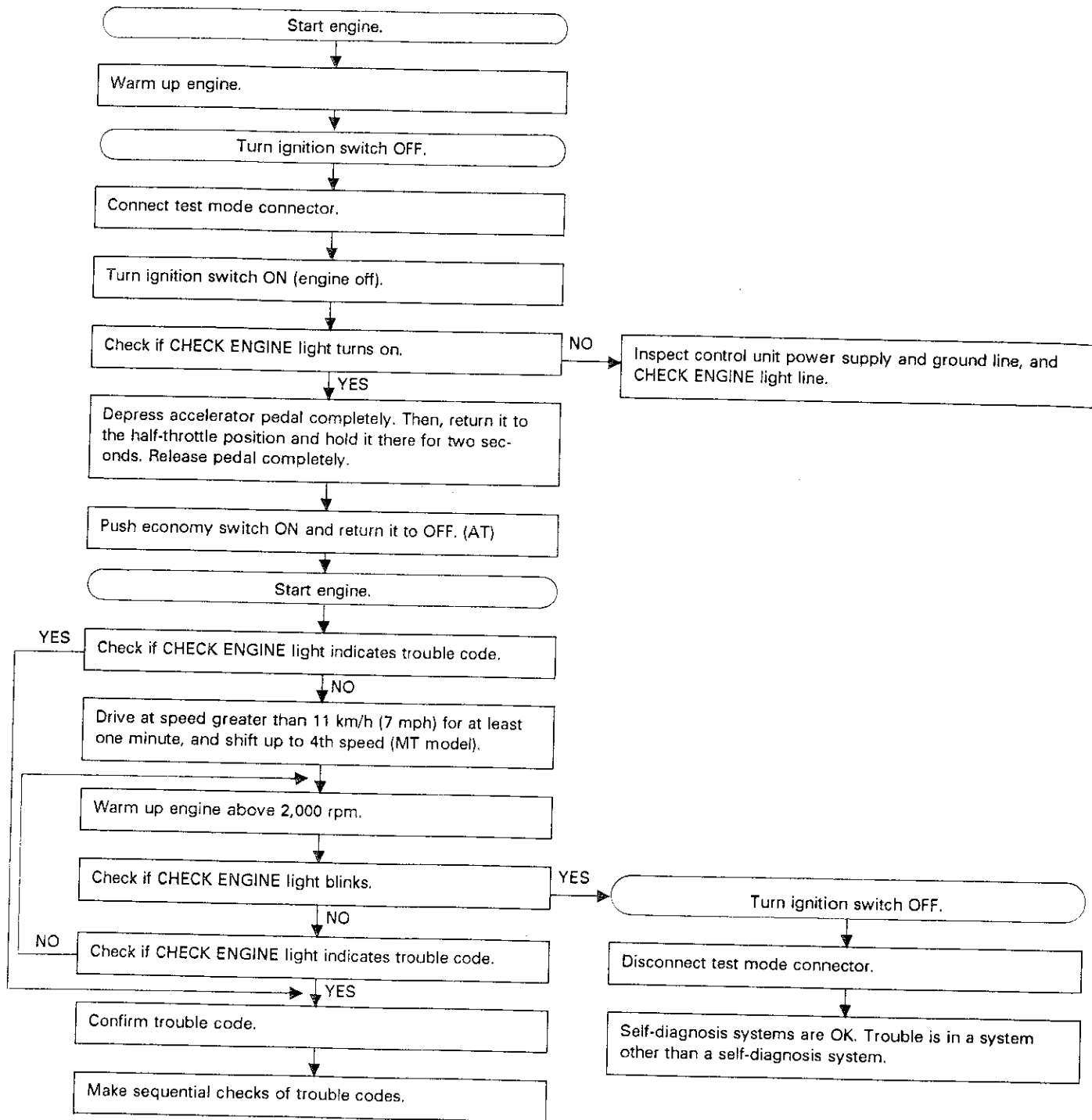


Fig. 30

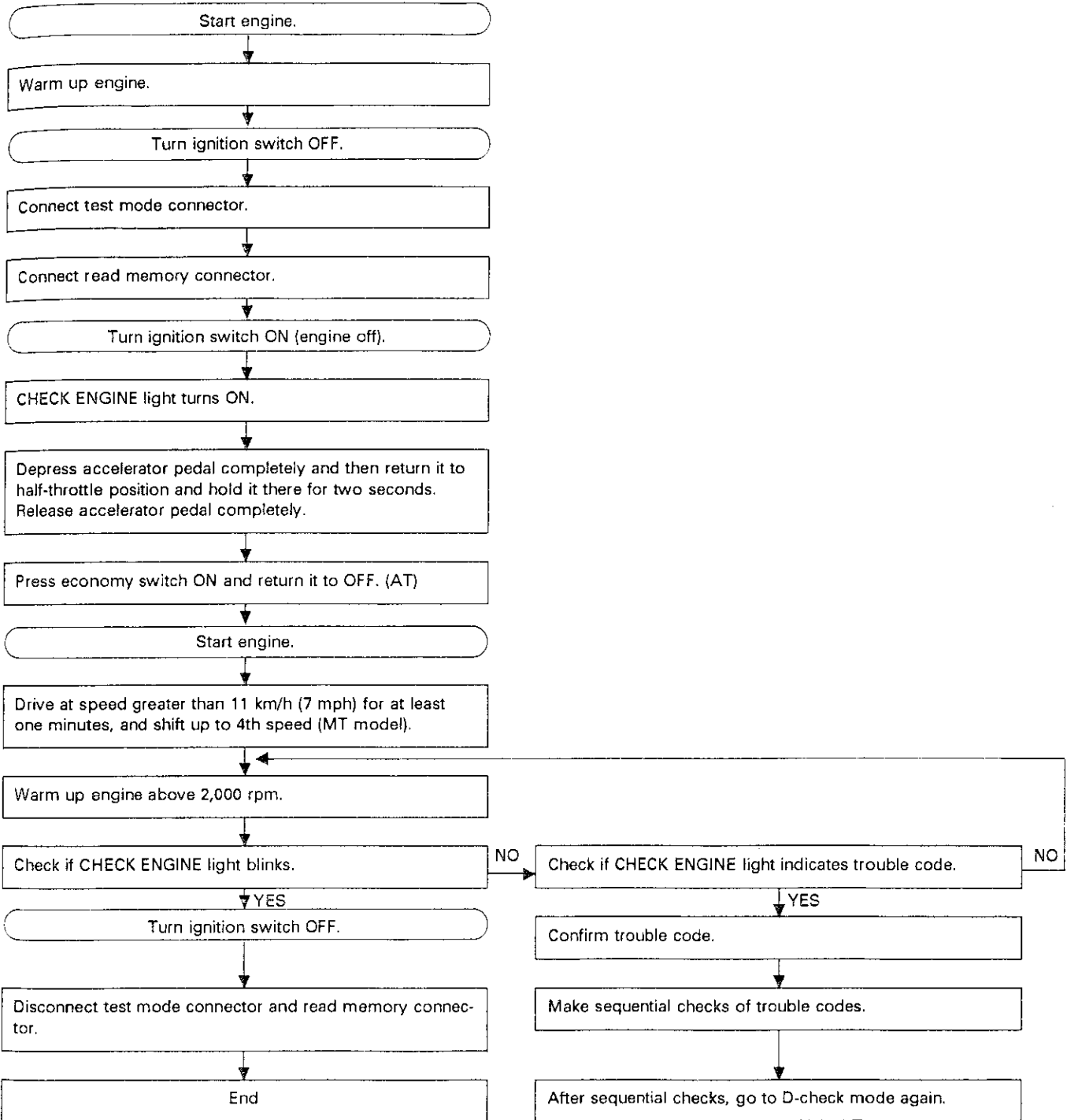
C: READ MEMORY MODE



D: D-CHECK MODE



E: CLEAR MEMORY MODE



4. Output Modes of Select Monitor

1. FUNCTION MODE

Applicable cartridge of select monitor: No. 498348800

MODE	Contents	Abbr.	Unit	Contents of display
F00	PROM ID Number	YEAR	—	Model year of vehicle to which select monitor is connected
F01	Battery Voltage	VB	V	Battery voltage supplied to control unit
F02	Vehicle Speed Sensor 2	VSP	MPH	Vehicle speed inputted from vehicle speed sensor 2
F03	Vehicle Speed Sensor 2	VSP	km/h	Vehicle speed inputted from vehicle speed sensor 2
F04	Engine speed	EREV	rpm	Engine speed inputted from crank angle sensor
F05	Water Temp Sensor	TW	deg F	Coolant temperature inputted from water temperature sensor
F06	Water Temp Sensor	TW	deg C	Coolant temperature inputted from water temperature sensor
F07	Ignition Timing	ADVS	deg	Ignition timing determined by ECU in relation to signals sent from various sensors
F08	Air Flow Sensor	QA	V	Voltage inputted from air flow meter
F09	Load Data	LDATA	—	Engine load value determined by related sensor signals
F10	Throttle Sensor	THV	V	Voltage inputted from throttle sensor
F11	Injector Pulse Width	TIM	mS	Duration of pulse flowing through injectors
F12	By-pass air control solenoid valve	ISC	%	"Duty" ratio flowing through solenoid valve
*F13	O ₂ Sensor	O ₂	V	Voltage outputted from O ₂ sensor
*F15	O ₂ Max	O ₂ max	V	Maximum voltage outputted from O ₂ sensor
*F16	O ₂ Min	O ₂ min	V	Minimum voltage outputted from O ₂ sensor
*F19	ALPHA	ALPHA	%	AF correction ratio determined in relation to signal outputted from O ₂ sensor
**F21	Knock Sensor	RTRD	deg	Ignition timing correction determined in relation to signal inputted from knock sensor
FA0	ON ↔ OFF Signal	—	—	—
FA1	ON ↔ OFF Signal	—	—	—
FA2	ON ↔ OFF Signal	—	—	—
FB0	Trouble Code	DIAG	—	Trouble code in U- or D-check mode
FB1	Trouble Code	DIAG	—	Trouble code in Read Memory mode
FC0	Clear Memory	—	—	(Used to clear memory)

*: Catalyst model only

** : 2200 cc model only

2. ON ↔ OFF SIGNAL LIST

MODE	LED No.	Contents	Display	LED "ON" requirements
FA0	1	Ignition SW	IG	Ignition switch "ON"
	2	AT/MT discrimination	AT	AT models only
	3	Test Mode	UD	Test mode connector connected
	4	Read Memory	RM	Read-memory connector connected
	7	Neutral SW	NT	Neutral switch "ON"
	8	Parking SW	PK	Parking switch "ON" [AT]
FA1	1	Idle SW	ID	Idle switch "ON"
	2	A/C SW	AC	Air conditioner switch "ON"
	3	A/C Relay	AR	Air conditioner relay "ON"
	4	Radiator Fan	RF	Radiator fan in operation
	6	Fuel Pump Relay	FP	Fuel pump relay in operation
	7	Purge control solenoid valve	CN	Solenoid valve in operation
	8	Knock Sensor	KS	Engine knocks occur
FA2	4	Economy SW	EC	Economy switch "ON"
FA3	10	O ₂ Monitor	O ₂	Mixture ratio is rich

5. Control Unit I/O Signal

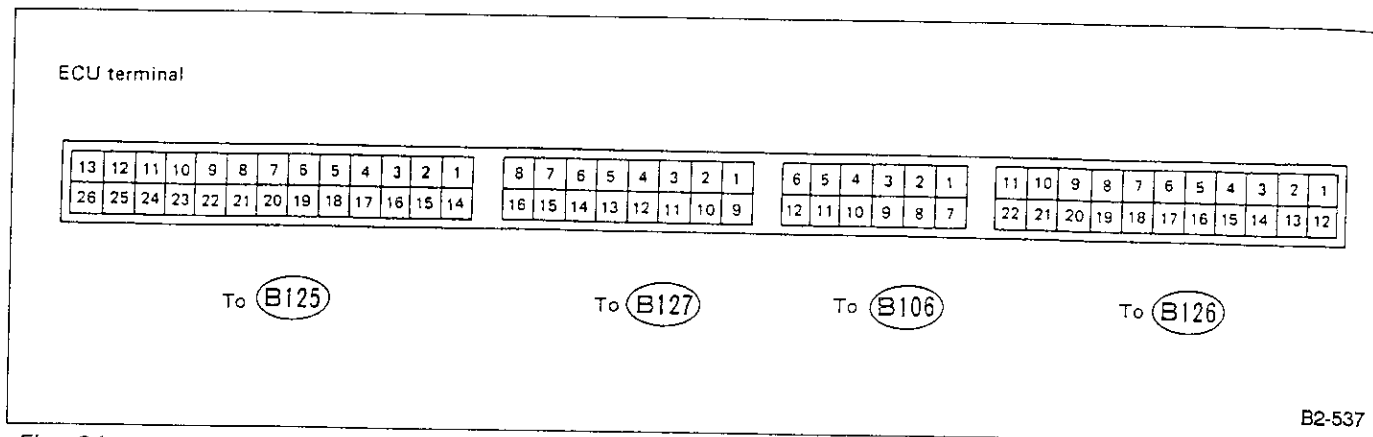


Fig. 31

Content	Con- nector No.	Ter- minal No.	Signal (V)			Note	
			Ig SW		Engine ON (Idling)		
			OFF	ON (Engine OFF)			
Crank angle sensor	Signal (+)	B127	1	—	0	*	*Sensor output waveform
	Signal (-)	B127	2	—	0	0	—
	Shield	B127	3	—	0	0	—
Cam angle sensor	Signal (+)	B106	4	—	0	*	*Sensor output waveform
	Signal (-)	B106	5	—	0	0	—
	Shield	B106	6	—	0	0	—
Air flow sensor	Power supply	B126	8	—	10 — 13	13 — 14	—
	Signal	B126	9	—	0 — 0.3	0.8 — 1.2	—
	GND	B126	10	—	0	0	—
Throttle sensor	Signal	B106	2	—	Fully closed: 4.7 Fully opened: 0.9	Fully closed: 4.7 Fully opened: 0.9	—
	Power supply	B106	3	—	5	5	—
	GND	B106	1	—	0	0	—
O ₂ sensor	Signal	B126	6	—	(AT) 0.1 — 0.9 (MT) 0.6	Rich mixture: 0.7 — 1.0 Lean mixture: 0 — 0.2	—
	Shield	B126	17	—	0	0	—
Knock sensor	Signal	B127	5	—	3 — 4	3 — 4	—
	Shield	B127	4	—	0	0	—
Water temperature sensor	B126	7	0	0.7 — 1.5	0.7 — 1.5	*After warm-up	
Vehicle speed sensor 2	B106	11	—	0 or 5	0 or 5	"5" and "0" are repeatedly displayed when vehicle is driven.	
Idle switch	B127	6	—	ON:0 OFF:5	ON:0 OFF:5	—	
Economy switch (AT)	B127	11	—	ON: 0 OFF: 10 — 13	ON: 0 OFF: 13 — 14	—	
Starter switch	B127	10	—	0	0	Cranking: 10 — 14	
Air conditioner switch	B127	9	—	ON:10 — 13 OFF:0	ON:13 — 14 OFF:0	—	
Ignition switch	B106	12	0	10 — 13	13 — 14	—	
Neutral switch	B106	10	—	[AT] N Range: 0 Other: 10 — 13 [MT] N Position: 7 Other: 0	[AT] N Range: 0 Other: 13 — 14 [MT] N Position: 7 Other: 0	—	
Parking switch [AT]	B106	9	—	P Range: 0 Other:10 — 3	P Range: 0 Other:13 — 14	—	
Test mode connector	B127	13	—	7	7	When connected: 0	

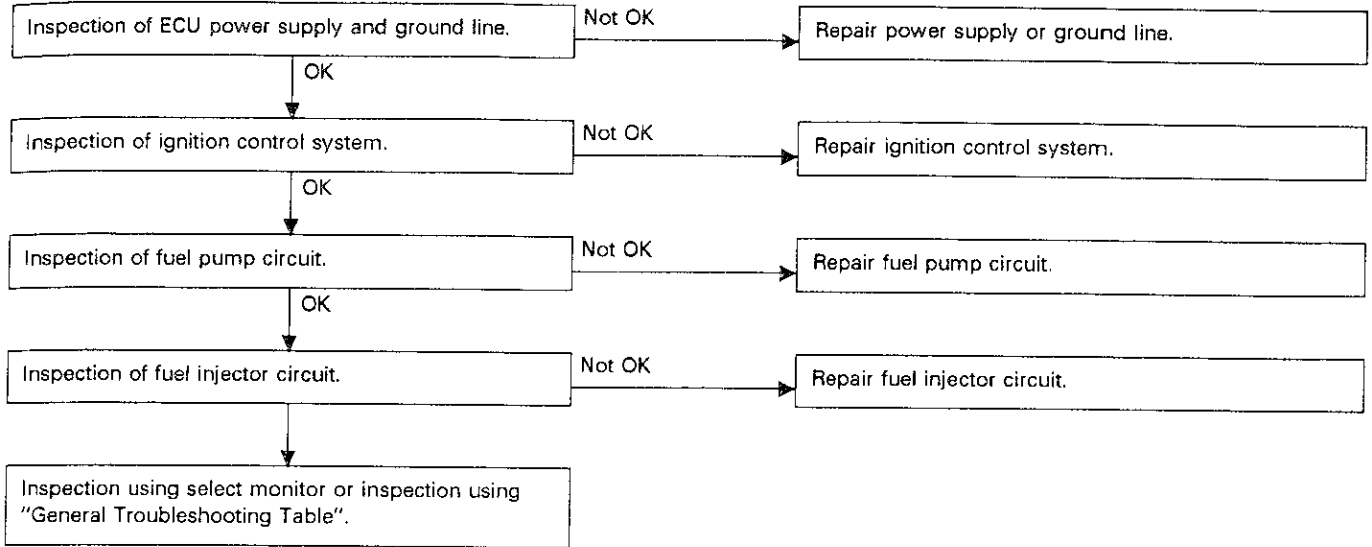
Content	Con- nector No.	Ter- minal No.	Signal (V)			Note	
			Ig SW		Engine ON (Idling)		
			OFF	ON (Engine OFF)			
Read memory connector	B127	12	—	7	7	When connected: 0	
AT/MT identification	B126	20	—	[AT] 0 [MT] 7	[AT] 0 [MT] 7	—	
Back-up power supply	B126	15	10 — 13	10 — 13	13 — 14	—	
Control unit power supply	B126	2	0	10 — 13	13 — 14	—	
	B126	13	0	10 — 13	13 — 14	—	
Ignition control	#1, #2	B125	10	—	0	—	—
	#3, #4	B125	9	—	0	—	—
Fuel injector	#1	B125	13	10 — 13	10 — 13	13 — 14	—
	#2	B125	12	10 — 13	10 — 13	13 — 14	—
	#3	B125	11	10 — 13	10 — 13	13 — 14	—
	#4	B125	26	10 — 13	10 — 13	13 — 14	—
By-pass air control solenoid valve	OPEN end	B125	2	—	8 — 9	9 — 10	—
	CLOSE end	B125	1	—	6 — 7	6 — 7	—
Fuel pump relay control	B125	23	—	ON: 0 OFF: 10 — 13	0	—	
Air conditioner cut relay control	B125	22	—	ON: 0 Off: 10 — 13	ON: 0 OFF: 13 — 14	—	
Radiator fan control	B125	17	—	ON: 0 OFF: 10 — 13	ON: 0 OFF: 13 — 14	—	
Self-shutoff control	B125	5	—	10 — 13	13 — 14	—	
Trouble code output	B127	15	—	—	—	—	
CHECK ENGINE light	B125	19	—	1, max.	—	Light "ON": 1, max. Light "OFF": 10 — 14	
Engine tachometer output	B127	16	—	—	—	—	
TI monitor*	B125	18	—	10 — 13	13 — 14	—	
Purge control solenoid valve	B125	6	—	ON: 0 OFF: 10 — 13	ON: 0 OFF: 13 — 14	—	
GND (sensors)	B126	21	—	0	0	—	
GND (injectors)	B125	24	—	0	0	—	
	B125	25	—	0	0	—	
Ignition system	B125	15	—	0	0	—	
GND (power supply)	B125	14	—	0	0	—	
GND (control systems)	B126	11	—	0	0	—	
	B126	22	—	0	0	—	
Select Monitor Signal	B127	8	—	—	—	—	
	B127	7	—	—	—	—	

*: For manufacture

6. Troubleshooting for Engine Starting Failure

A: BASIC TROUBLESHOOTING CHART

When engine cranks but does not start, troubleshoot in accordance with the following chart.



B: CONTROL UNIT POWER SUPPLY AND GROUND LINE

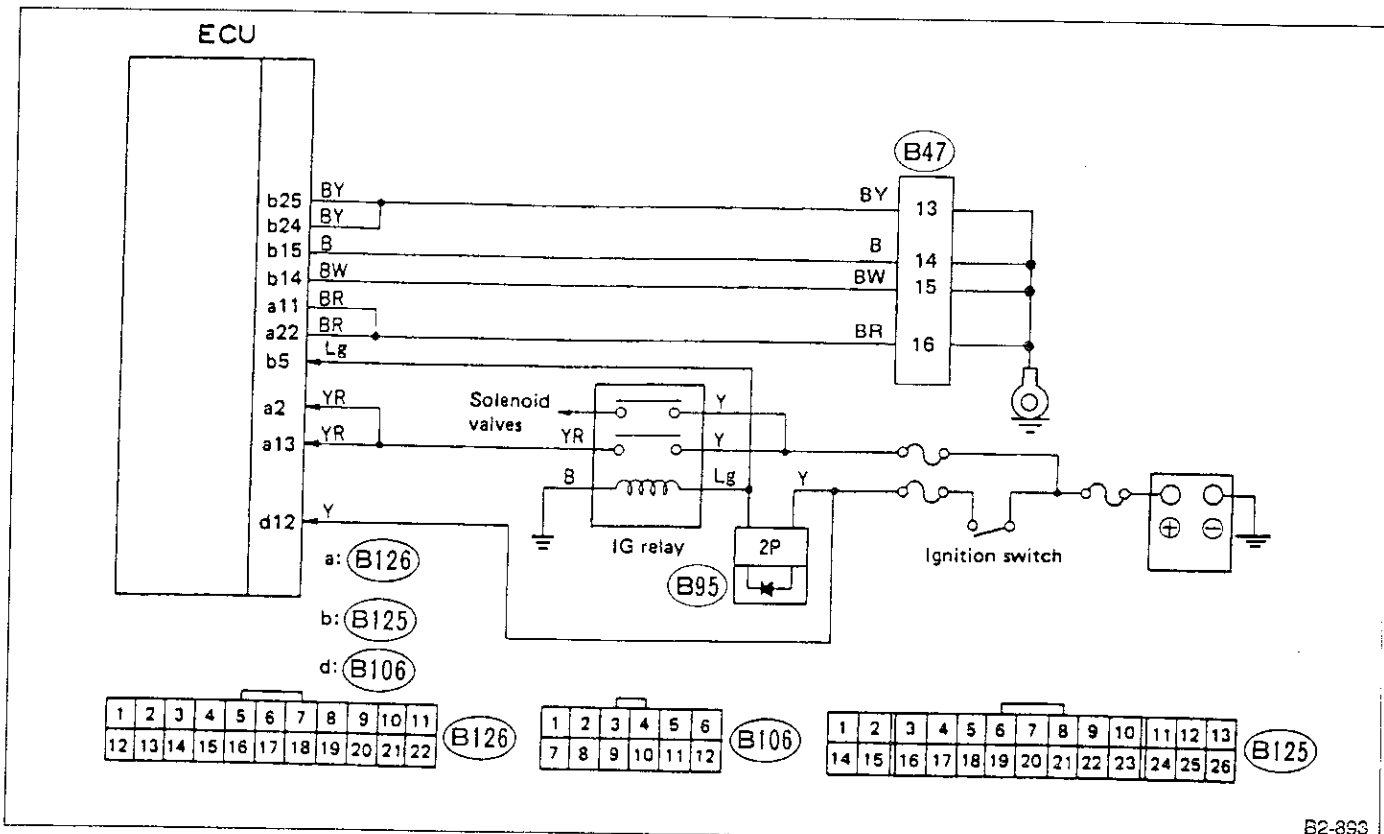
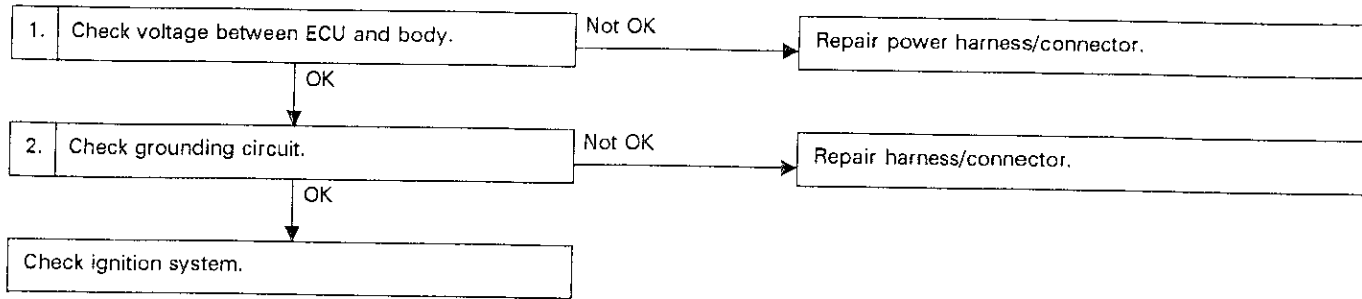


Fig. 32

B2-893

1. CHECK VOLTAGE BETWEEN ECU AND BODY.

- 1) Turn the ignition switch to "ON".
- 2) Measure voltage between ECU connector terminals and body.

Connector & Terminal/Specified voltage:

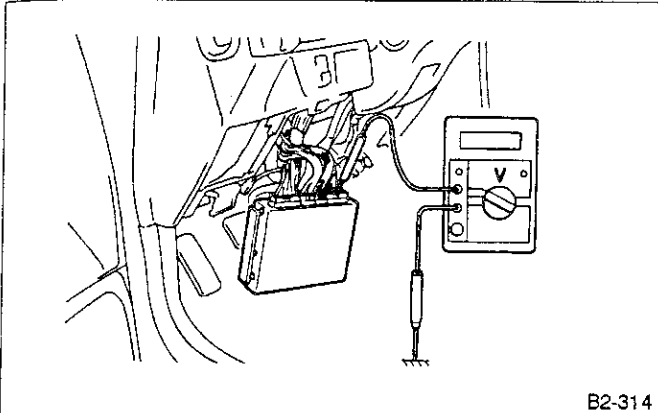
- (B106) No. 12 — Body/10 V, min.
- (B126) No. 15 — Body/10 V, min.
- (B126) No. 2 — Body/10 V, min.
- (B126) No. 13 — Body/10 V, min.

2. CHECK GROUNDING CIRCUIT.

- 1) Disconnect ECU connector.
- 2) Check continuity between ECU connector terminals and body.

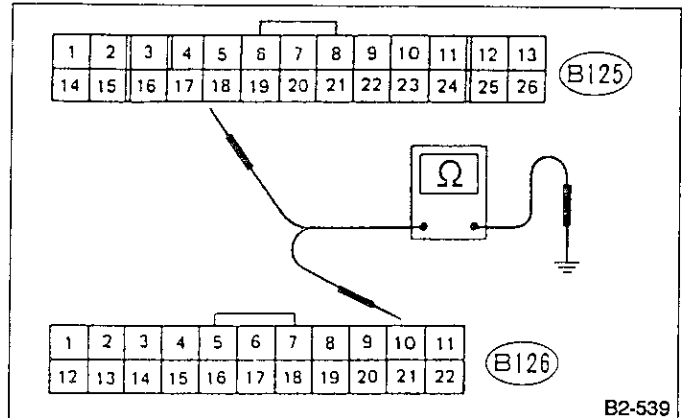
Connector & Terminal/Specified resistance:

- (B125) No. 24 — Body/0 Ω
- (B125) No. 25 — Body/0 Ω
- (B125) No. 14 — Body/0 Ω
- (B125) No. 15 — Body/0 Ω
- (B126) No. 11 — Body/0 Ω
- (B126) No. 22 — Body/0 Ω



B2-314

Fig. 33



B2-539

Fig. 34

C: IGNITION CONTROL SYSTEM

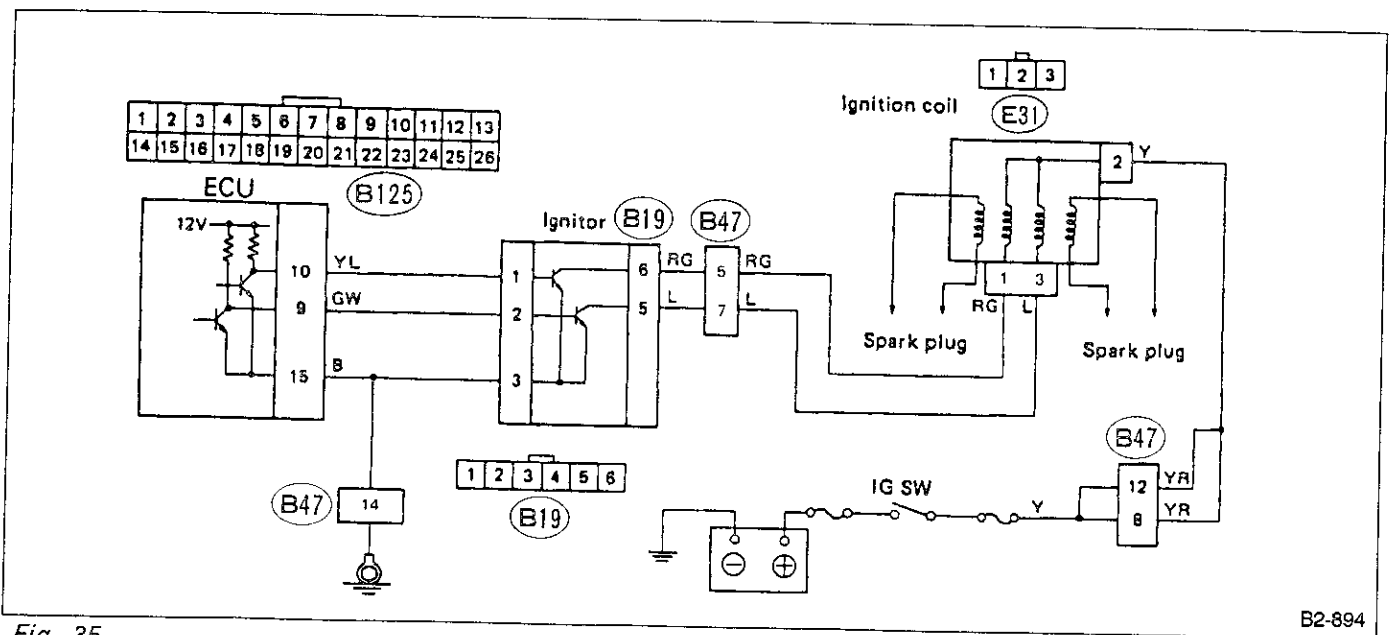
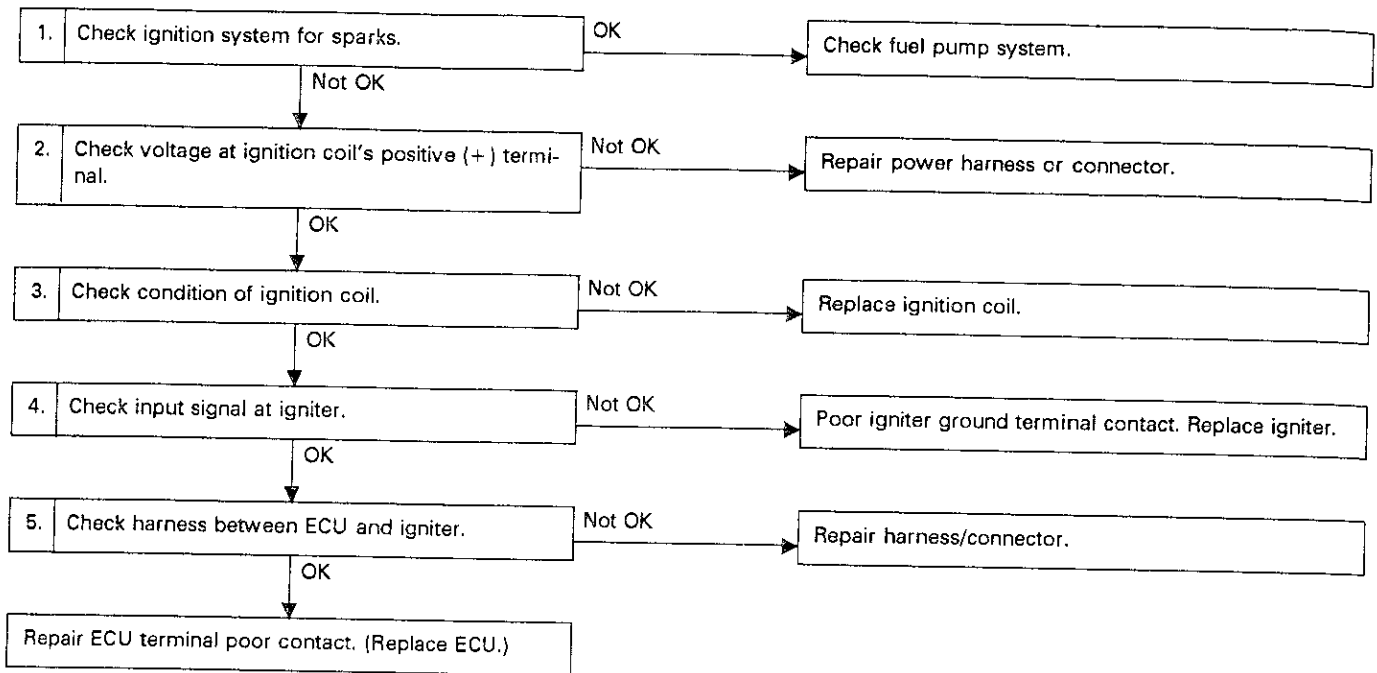


Fig. 35

B2-894

1. CHECK IGNITION SYSTEM FOR SPARKS.

- 1) Remove plug cord cap from each spark plug.
- 2) Install new spark plug on plug cord cap. (Do not remove spark plug from engine.)
- 3) Contact spark plug's thread portion on engine.
- 4) Crank engine to check that spark occurs at each cylinder.

2. CHECK VOLTAGE AT IGNITION COIL'S POSITIVE (+) TERMINAL.

- 1) Turn ignition switch to "ON".
- 2) Measure voltage between positive terminal of ignition coil connector and body.

Connector & Terminal/Specified voltage:
 (E31) No. 2 — Body/10 V, min.

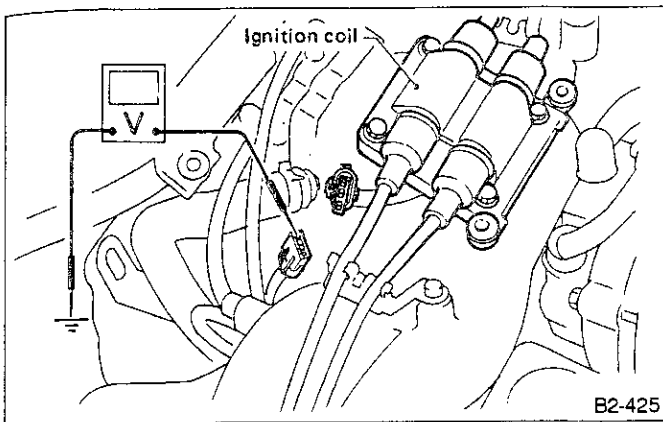


Fig. 36

3. CHECK CONDITION OF IGNITION COIL.

- 1) Disconnect ignition coil connector.
- 2) Remove ignition coil from engine.
- 3) Measure resistance of ignition coil's primary and secondary windings.

• Primary side

Connector & Terminal/Specified resistance:

To (E31) No. 2 — No. 1/0.7 Ω

To (E31) No. 2 — No. 3/0.7 Ω

• Secondary side

Connector & Terminal/Specified resistance:

#1 — #2/13.8 kΩ

#3 — #4/13.8 kΩ

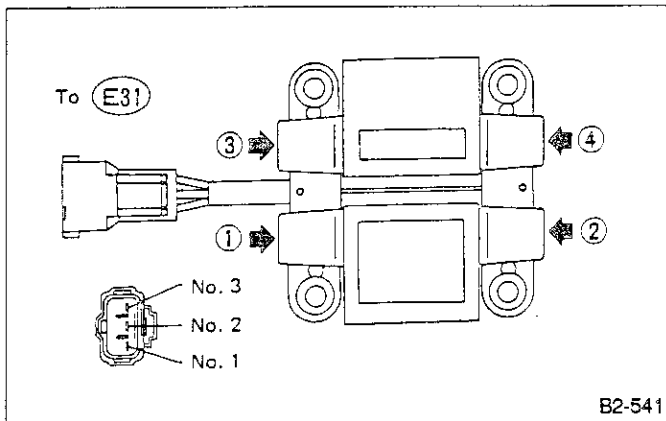


Fig. 37

4. CHECK INPUT SIGNAL AT IGNITER.

Check if voltage varies synchronously with engine revolution when cranking, while monitoring voltage between igniter connector and body.

Connector & Terminal

(B19) No. 1 — Body/0 ↔ *4V

(B19) No. 2 — Body/0 ↔ *4V

*: As the out put voltage is a pulse signal, this inspection data varies between 1 and 4V according to the type of tester.

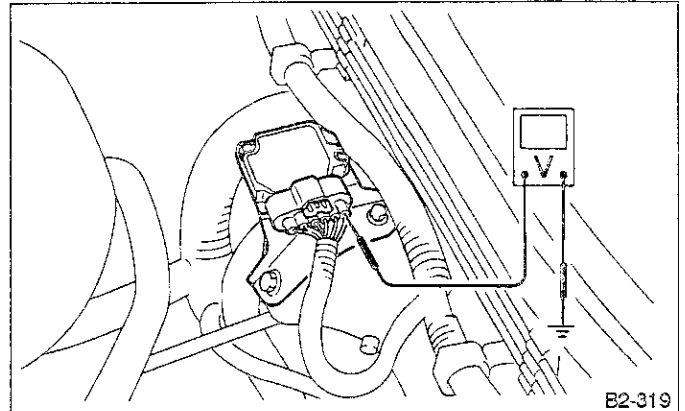


Fig. 38

5. CHECK HARNESS BETWEEN ECU AND IGNITER.

- 1) Disconnect ECU connector and igniter connector.
- 2) Check discontinuity between ECU- and igniter- connector terminals.

Connector & Terminal/Specified resistance:

(B125) No. 9 — (B19) No. 2/0 Ω

(B125) No. 10 — (B19) No. 1/0 Ω

(B125) No. 15 — (B19) No. 3/0 Ω

(B19) No. 3 — Body/0 Ω

- 3) Measure resistance between connector terminals and body to check shortcircuit.

Connector & Terminal/Specified resistance:

(B19) No. 1 — Body/1 MΩ min.

(B19) No. 2 — Body/1 MΩ min.

D: FUEL PUMP CIRCUIT

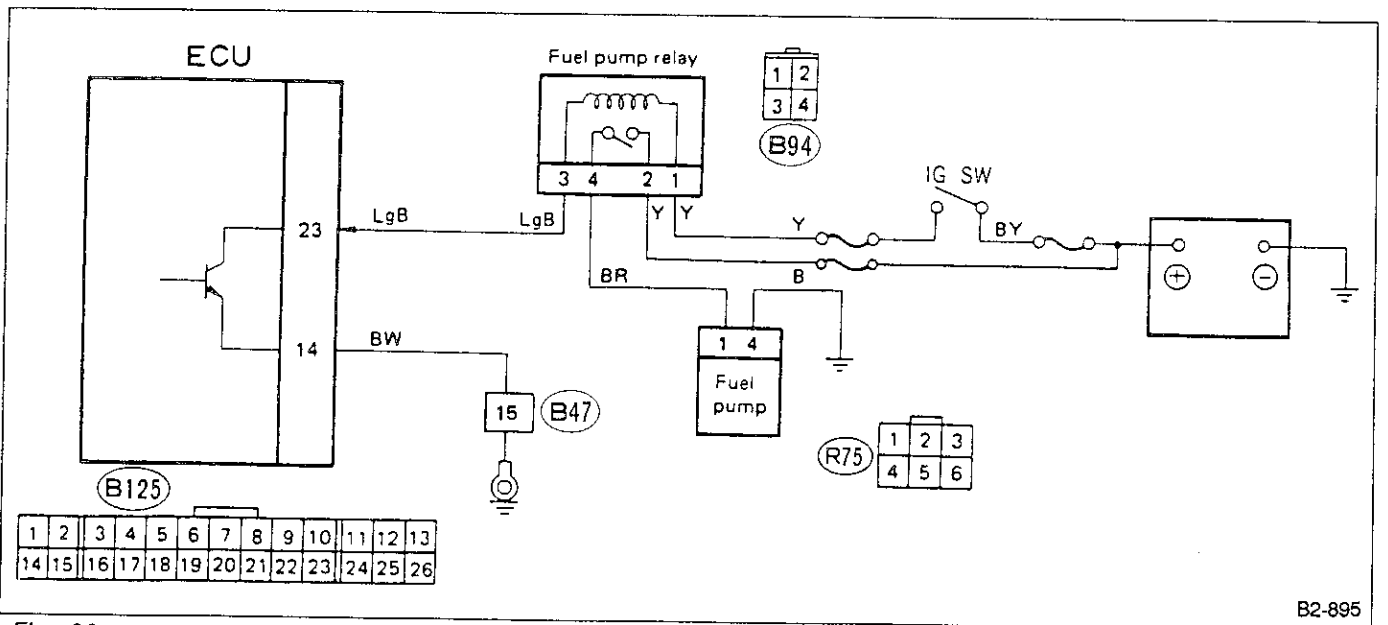
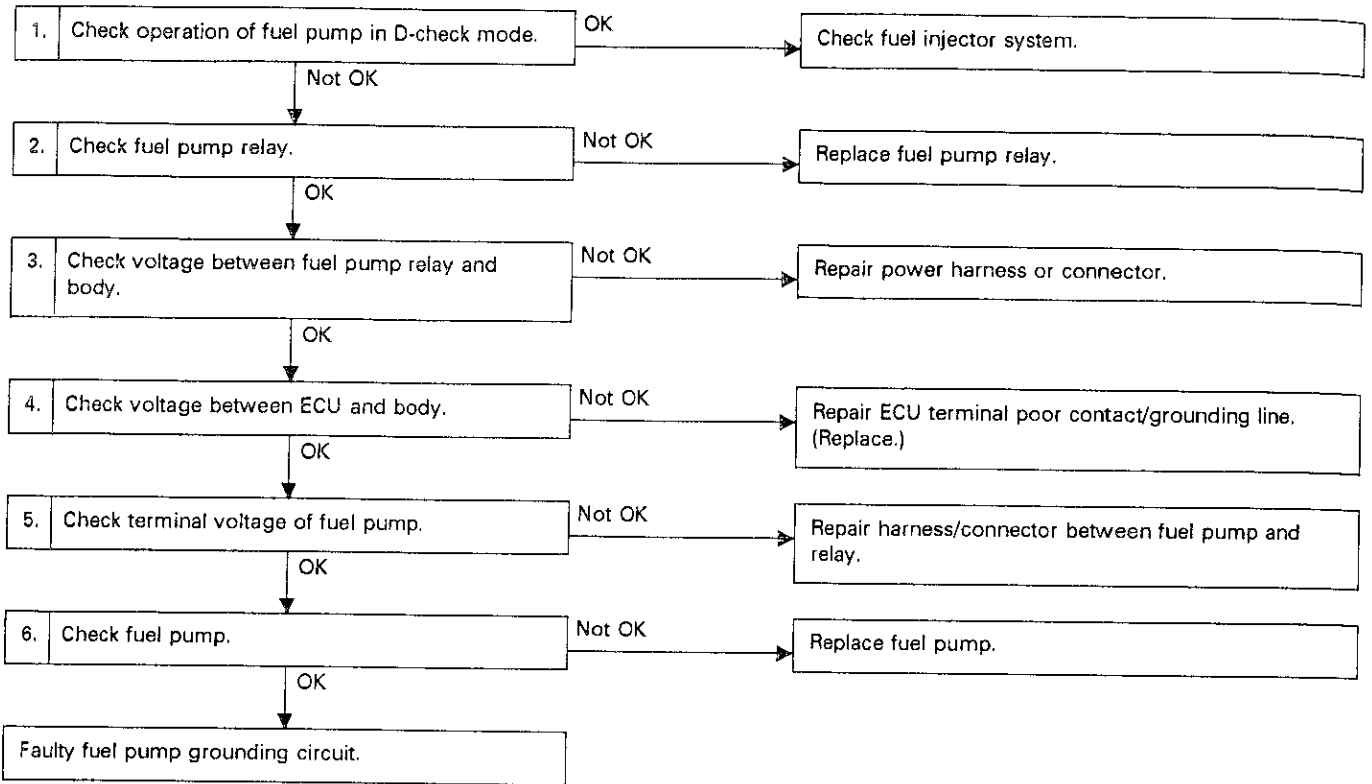


Fig. 39

1. CHECK OPERATION OF FUEL PUMP IN D-CHECK MODE.

- 1) Connect test-mode connector.
- 2) Turn ignition switch to "ON".
- 3) Check fuel pump for proper operation.

2. CHECK FUEL PUMP RELAY.

- 1) Disconnect fuel pump relay connector and remove relay from bracket.
- 2) Measure resistance of relay coil.

Terminal/Specified resistance:
No. 1 — No. 3/70 Ω

- 3) Connect battery (12 volts) to fuel pump relay coil terminals and check continuity between switching terminals. (Relay must issue clicks.)

Terminal/Specified resistance:
No. 2 — No. 4/0 Ω
(No. 1: Battery +)
(No. 3: Battery -)

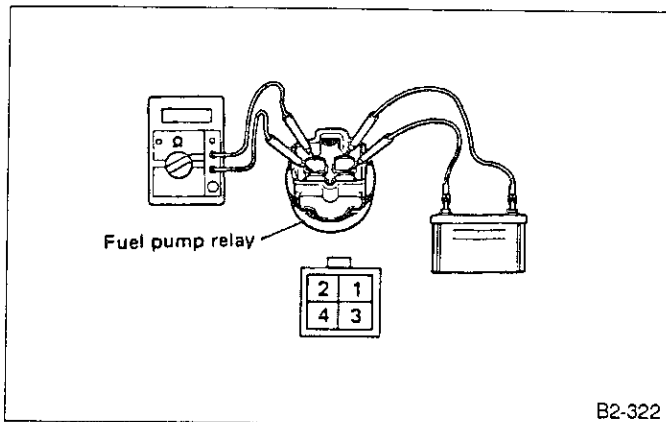


Fig. 40

3. CHECK VOLTAGE BETWEEN FUEL PUMP RELAY AND BODY.

- 1) Turn ignition switch to "OFF", and remove fuel pump relay. (Do not disconnect connector.)
- 2) Measure voltage between fuel pump relay connector and body.

Connector & Terminal/Specified voltage:
(B94) No. 1 — Body/10 V, min.

4. CHECK VOLTAGE BETWEEN ECU AND BODY.

- 1) Turn ignition switch to "ON".
- 2) Measure voltage when ignition switch is in "ON". Also measure voltage when cranking the engine.

Connector & Terminal/Specified voltage:
(B125) No. 23 — Body/
10 V, min. (Ignition ON)
0 V (when cranking the engine)

5. CHECK TERMINAL VOLTAGE OF FUEL PUMP.

- 1) Remove access lid of fuel pump located in trunk compartment and remove fuel pump connector.
- 2) Measure voltage between connector and body while cranking the engine.

Connector & Terminal/Specified voltage:
(R75) No. 1 — Body/10 V, min.

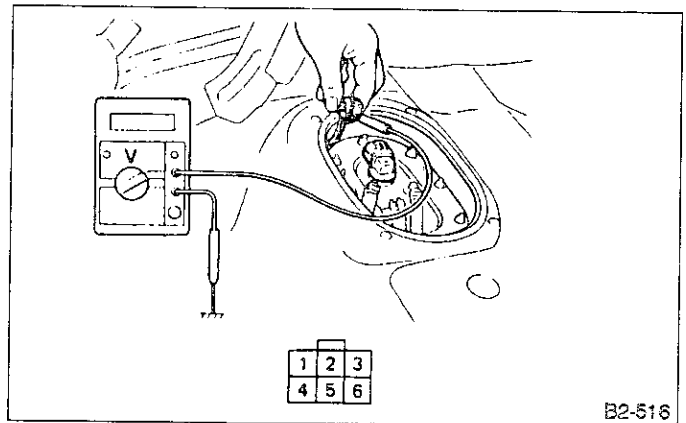


Fig. 41

6. CHECK FUEL PUMP.

- 1) Disconnect fuel pump connector.
- 2) Connect 12-volt battery to proper fuel pump connector terminal and GND terminal to check fuel pump operation.

Terminal:
No. 1 → Battery (+)
No. 4 → Battery (-)

E: FUEL INJECTOR CIRCUIT

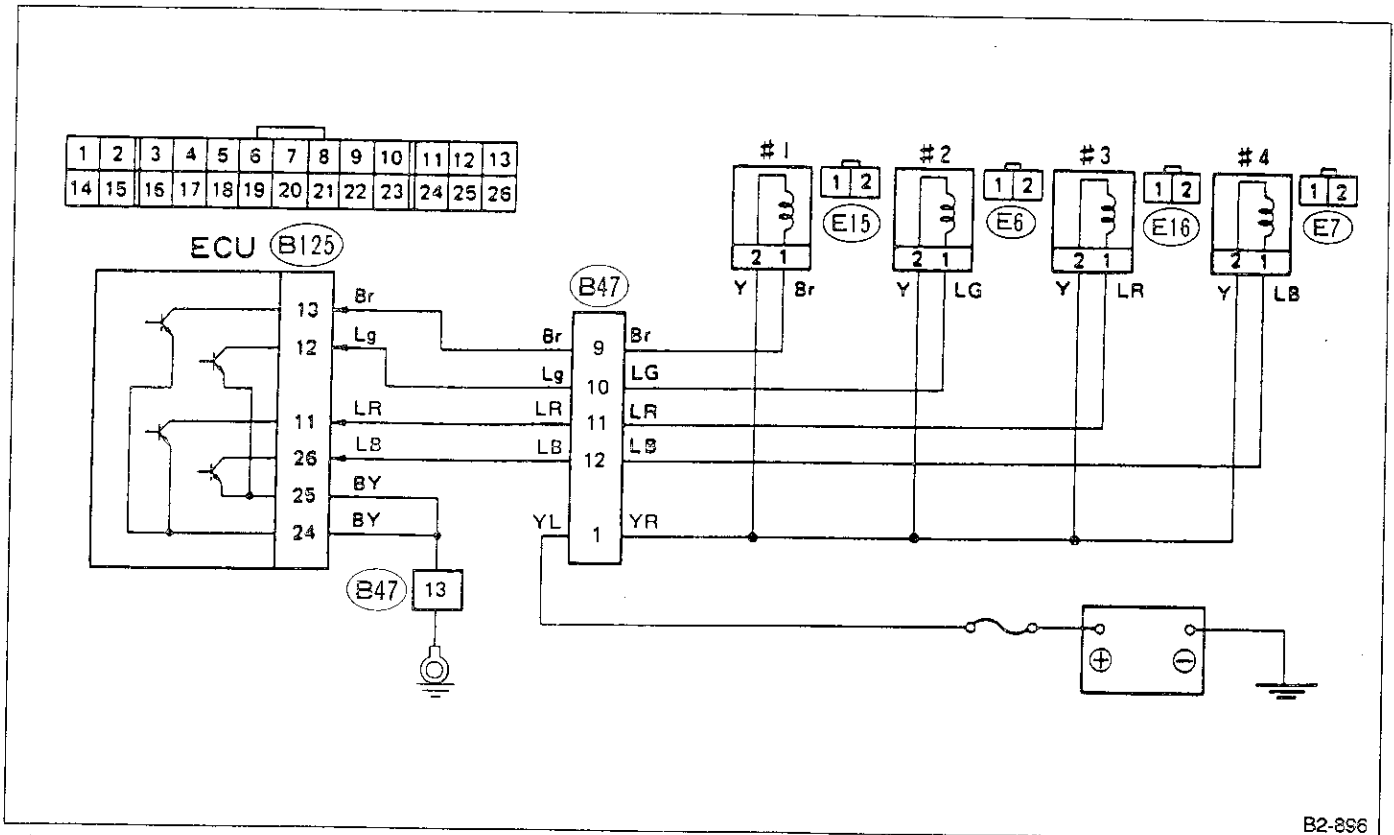
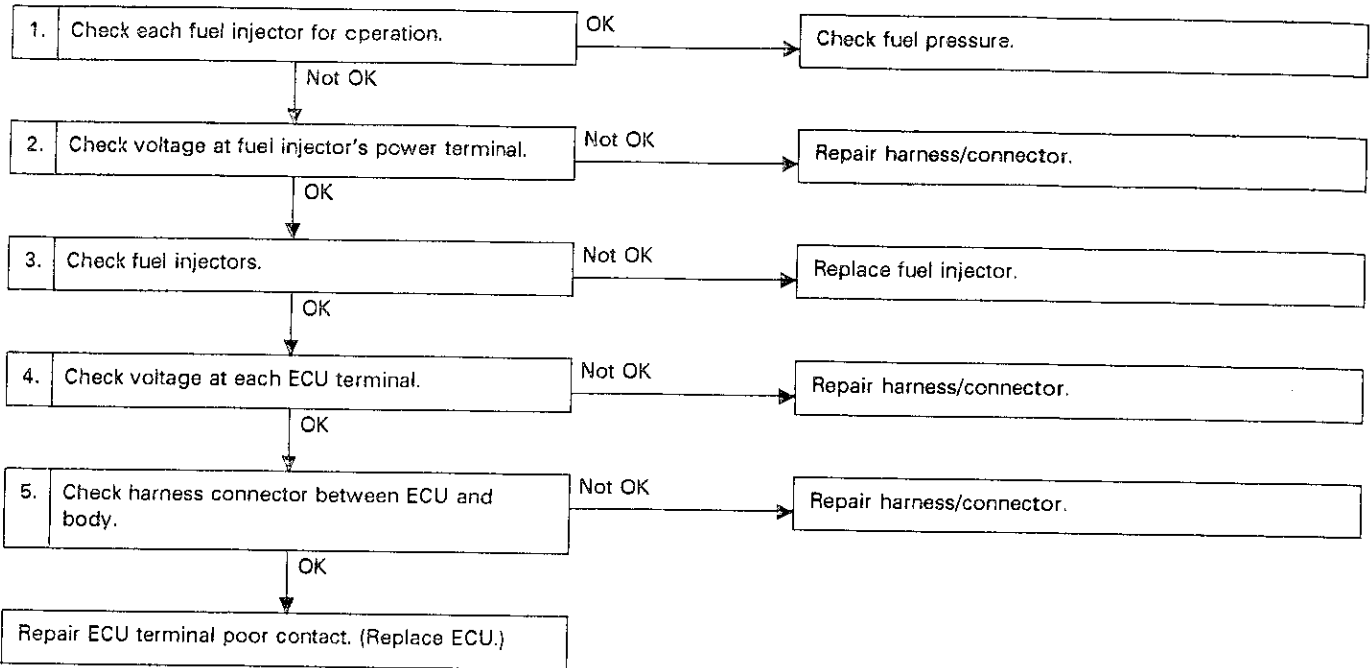


Fig. 42

B2-896

1. CHECK EACH FUEL INJECTOR FOR OPERATION.

While cranking the engine, check that each fuel injector emits "operating" sound. Use a sound scope or attach a screwdriver to injector for this check.

2. CHECK VOLTAGE AT FUEL INJECTOR POWER TERMINAL.

- 1) Disconnect connector from injector.
- 2) Measure voltage between injector connector power terminal and body.

Connector & Terminal/Specified voltage:

- (E15) No. 2 — Body/10 V, min.
- (E6) No. 2 — Body/10 V, min.
- (E16) No. 2 — Body/10 V, min.
- (E7) No. 2 — Body/10 V, min.

3. CHECK FUEL INJECTORS.

- 1) Disconnect connector from injector.
- 2) Measure resistance between injector terminals.

Specified register:

11 ~ 12 Ω

4. CHECK VOLTAGE AT EACH ECU TERMINAL.

Measure voltage between each fuel injector terminal of ECU connector and body.

(Fuel injector connector is connected.)

Connector & Terminal/Specified voltage:

- (B125) No. 11 — Body/10 V, min.
- (B125) No. 12 — Body/10 V, min.
- (B125) No. 13 — Body/10 V, min.
- (B125) No. 26 — Body/10 V, min.

5. CHECK HARNESS CONNECTOR BETWEEN ECU AND BODY.

- 1) Disconnect connector from ECU.
- 2) Measure resistance between ECU connector and body.

Connector & Terminal/Specified resistance:

- (B125) No. 24 — Body/0 Ω
- (B125) No. 25 — Body/0 Ω

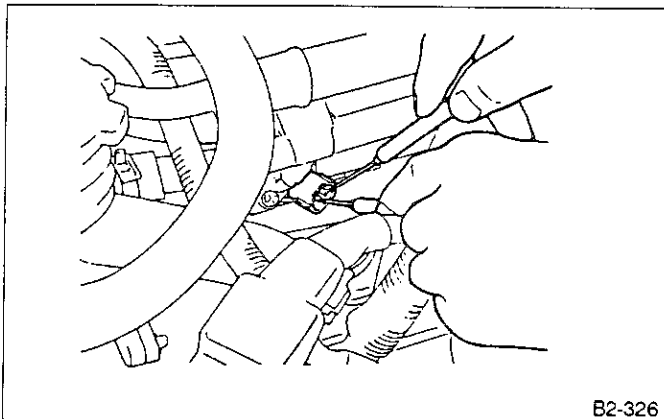


Fig. 43

7. Troubleshooting Chart with Trouble Code

A: TROUBLE CODE (11) — CRANK ANGLE SENSOR —

CONTENT OF DIAGNOSIS:

No signal entered from crank angle sensor, but signal (corresponding to at least one rotation of crank) entered from cam angle sensor

TROUBLE SYMPTOM:

Engine stall Restarting impossible

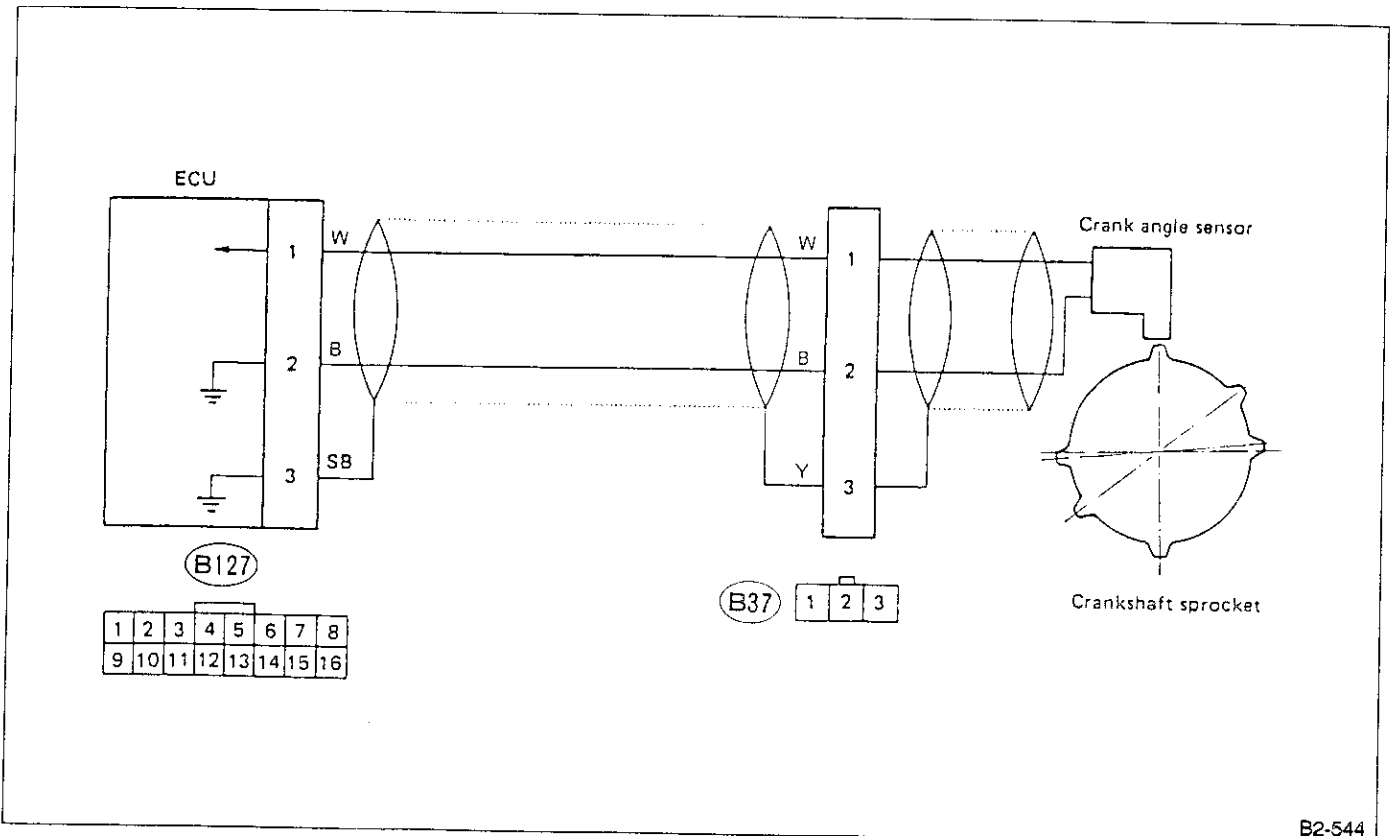
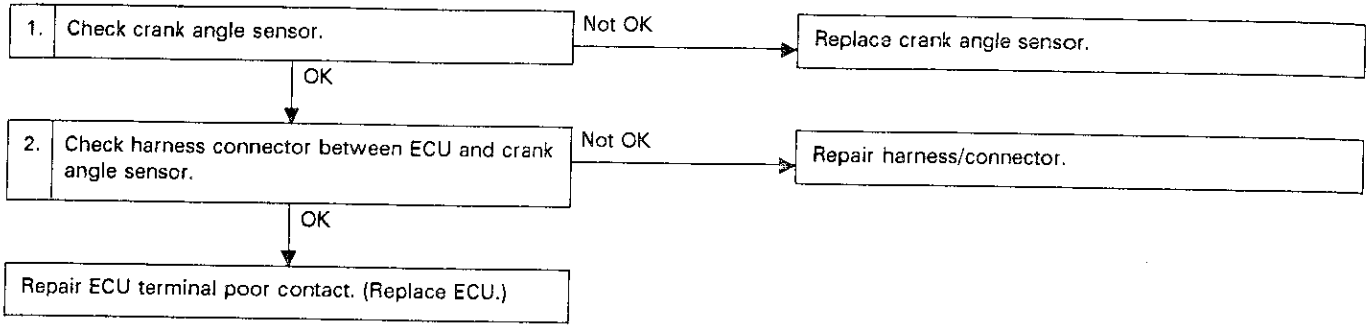


Fig. 44

B2-544

1. CHECK CRANK ANGLE SENSOR.

- 1) Disconnect crank angle sensor connector.
- 2) Check if voltage varies synchronously with engine revolutions when cranking, while monitoring voltage between crank angle sensor connector terminals (AC 0.1 V, min.).

Terminal:

No. 1 — No. 2

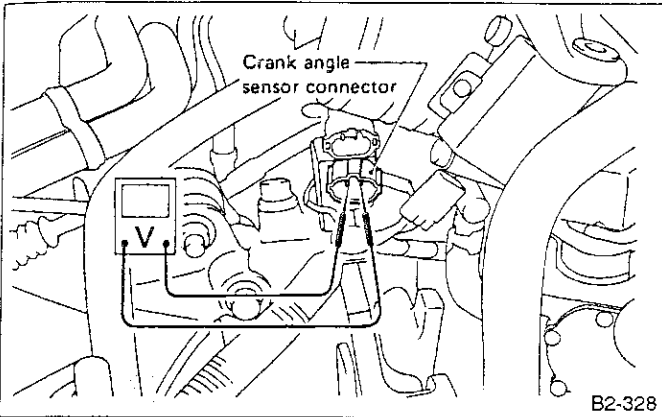


Fig. 45

2. CHECK HARNESS CONNECTOR BETWEEN ECU AND CRANK ANGLE SENSOR.

- 1) Disconnect connectors from ECU and crank angle sensor.
- 2) Measure resistance between ECU connector and angle sensor connector.

Connector & Terminal/Specified resistance:

(B127) No. 1 — (B37) No. 1/0 Ω

(B127) No. 2 — (B37) No. 2/0 Ω

(B127) No. 3 — (B37) No. 3/0 Ω

- 3) Measure resistance between crank angle sensor connector and body.

Connector & Terminal/Specified resistance:

(B37) No. 1 — Body/1 MΩ min.

(B37) No. 2 — Body/1 MΩ min.

- 4) Connect ECU connector and measure resistance between crank angle sensor sealed terminal and body.

Connector & Terminal/Specified resistance:

(B37) No. 3 — Body/0 Ω

- 5) Disconnect cam angle sensor connector and measure resistance between sealed terminal and body.

Connector & Terminal/Specified resistance:

(B39) No. 3 — Body/0 Ω

• SELECT MONITOR FUNCTION MODE

Mode: F04

Condition: Engine at idle

Specified Data: EREV F04

700 rpm (A/C OFF)

850 rpm (A/C ON)

B: TROUBLE CODE (12) — STARTER SWITCH —

CONTENT OF DIAGNOSIS:
Abnormal signal emitted from ignition starter switch

TROUBLE SYMPTOM:
Failure of engine to start

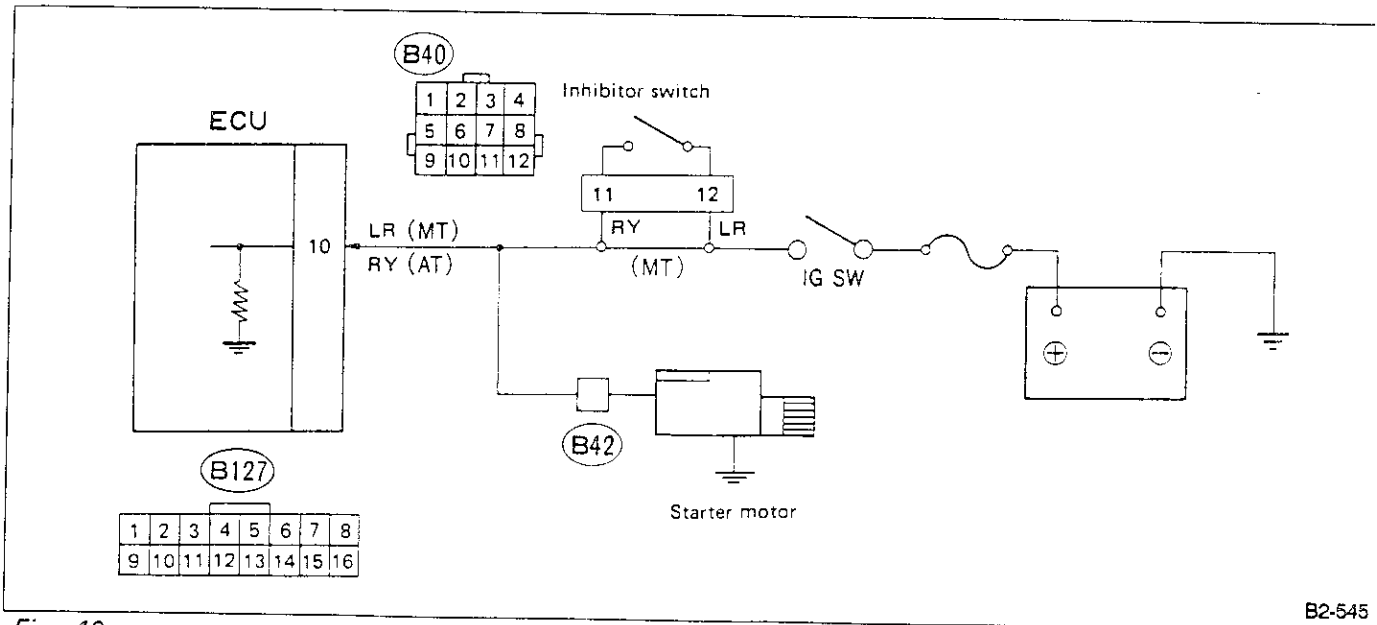
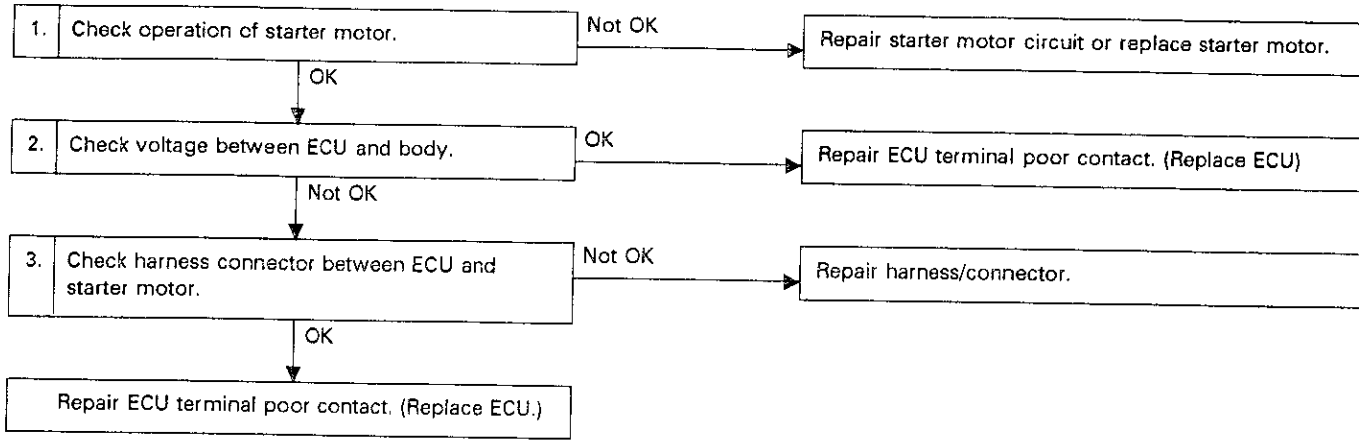


Fig. 46

B2-545

1. CHECK OPERATION OF STARTER MOTOR.

Turn ignition switch to "ST" to ensure that starter motor functions.

2. MEASURE VOLTAGE BETWEEN ECU AND BODY.

Measure voltage between ECU connector terminal and body while cranking the engine.

Connector & Terminal/Specified voltage:
(B127) No. 10 — Body/9 — 10 V, min.

3. CHECK HARNESS CONNECTOR BETWEEN ECU AND STARTER MOTOR.

- 1) Disconnect connectors from ECU and starter motor.
- 2) Measure resistance between ECU connector and starter motor connector.

Connector & Terminal/Specified resistance:
(B127) No. 10 — (B42) No. 1/0 Ω

- 3) Measure resistance between starter motor connector and body.

Connector & Terminal/Specified resistance:
(B42) No. 1 — Body/1 M Ω min.

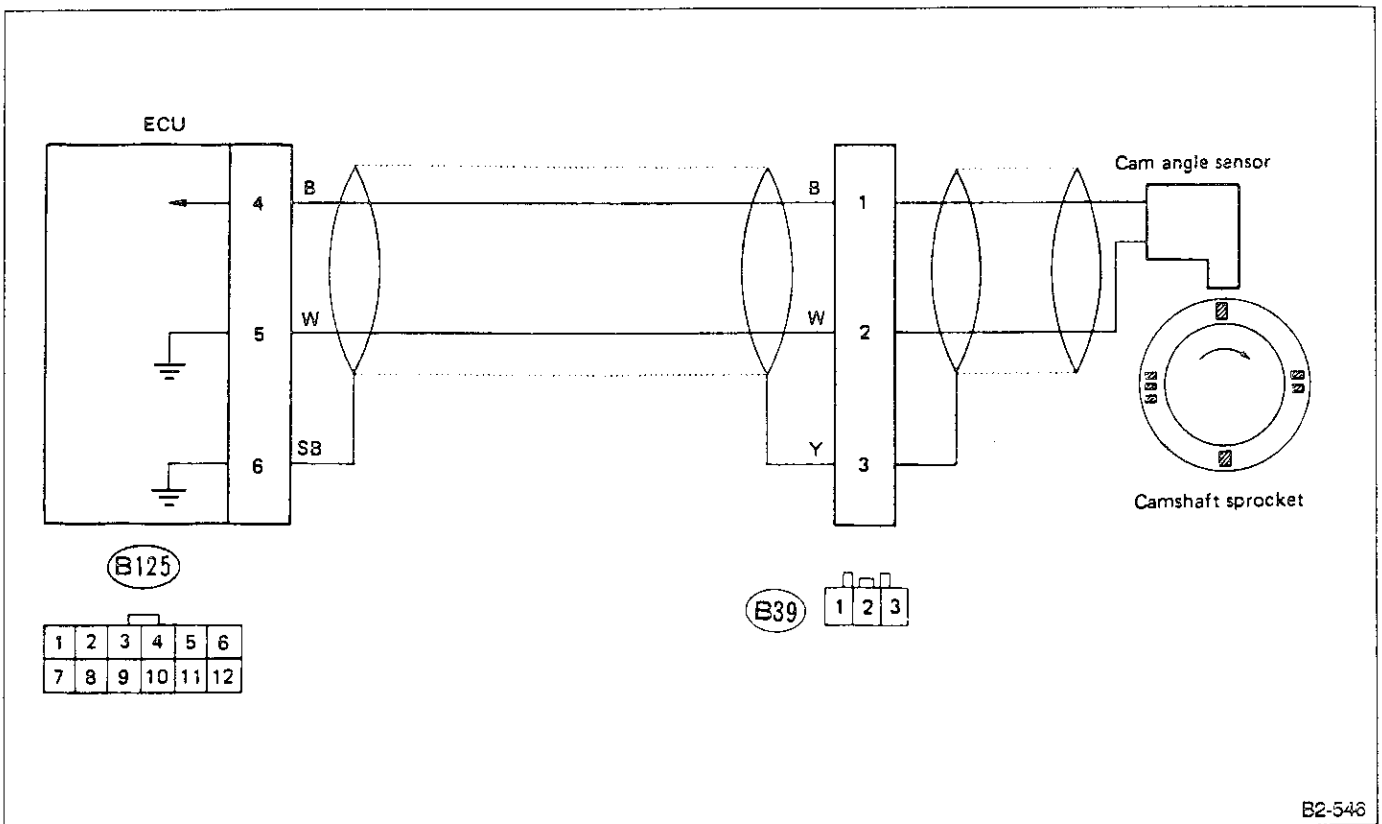
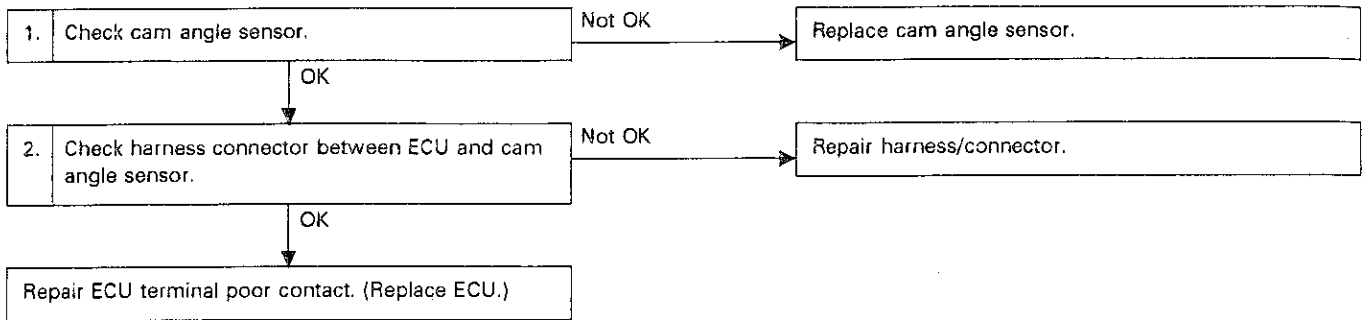
C: TROUBLE CODE (13) — CAM ANGLE SENSOR —

CONTENT OF DIAGNOSIS:

No signal entered from cam angle sensor, but signal (corresponding to at least two rotations of cam) entered from crank angle sensor

TROUBLE SYMPTOM:

Engine stall Failure of engine to start



B2-546

Fig. 47

1. CHECK CAM ANGLE SENSOR.

- 1) Disconnect cam angle sensor connector.
- 2) Check if voltage varies synchronously with engine revolutions when cranking, while monitoring voltage between cam angle sensor connector terminals (AC 0.1 V, min.).

Terminal :

No.1 — No.2

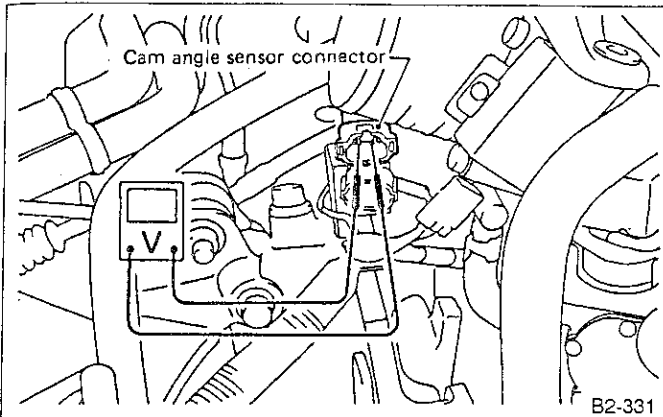


Fig. 48

2. CHECK HARNESS CONNECTOR BETWEEN ECU AND CAM ANGLE SENSOR.

- 1) Disconnect connectors from ECU and cam angle sensor.
- 2) Measure resistance between ECU connector and cam angle sensor connector.

Connector & Terminal/Specified resistance:

- (B106) No. 4 — (B39) No. 1/0 Ω
- (B106) No. 5 — (B39) No. 2/0 Ω
- (B106) No. 6 — (B39) No. 3/0 Ω

- 3) Measure resistance between cam angle sensor connector and body.

Connector & Terminal/Specified resistance:

- (B39) No. 1 — Body/1 MΩ min.
- (B39) No. 2 — Body/1 MΩ min.

- 4) Connect ECU connector and measure resistance between cam angle sensor sealed terminal and body.

Connector & Terminal/Specified resistance:

- (B39) No. 3 — Body/0 Ω

- 5) Disconnect crank angle sensor connector and measure resistance between sealed terminal and body.

Connector & Terminal/Specified resistance:

- (B37) No. 3 — Body/0 Ω

• **SELECT MONITOR FUNCTION MODE**

Mode: F04

Condition: Engine at idle

Specified Data: EREV F04

700 rpm (A/C OFF)

850 rpm (A/C ON)

D: TROUBLE CODE (14, 15, 16, 17) — FUEL INJECTOR —

CONTENT OF DIAGNOSIS:
Fuel injector inoperative

TROUBLE SYMPTOM:
 • Engine stall
 • Erroneous idling
 • Rough driving

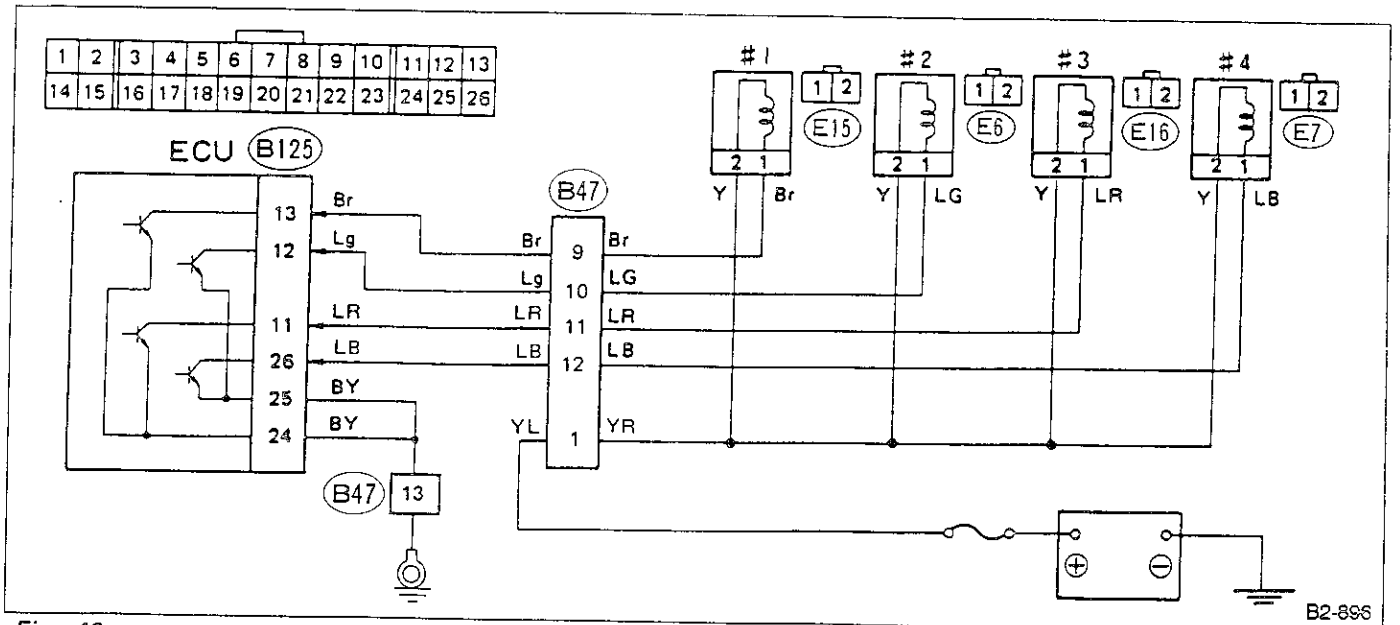
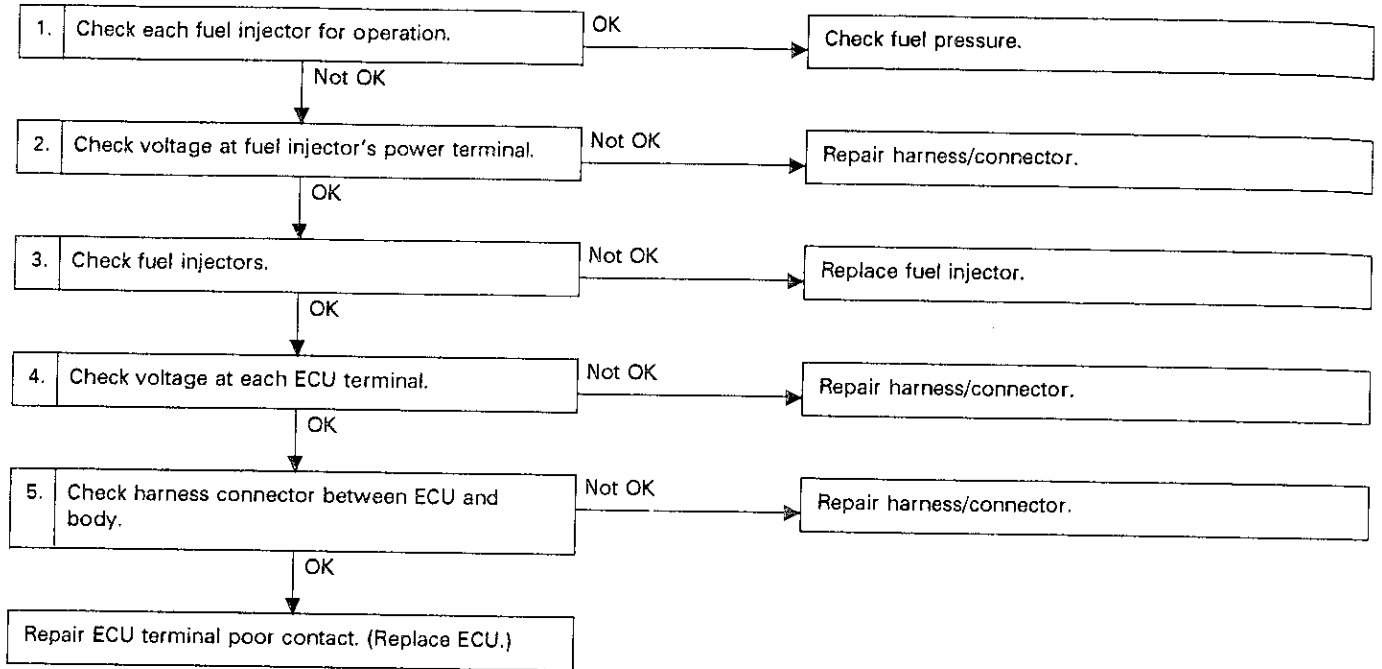


Fig. 49

B2-896

1. CHECK EACH FUEL INJECTOR FOR OPERATION.

While cranking the engine, check that each fuel injector emits "operating" sound. Use a sound scope or attach a screwdriver to injector for this check.

2. CHECK VOLTAGE AT FUEL INJECTOR POWER TERMINAL.

- 1) Disconnect connector from injector.
- 2) Measure voltage between injector connector power terminal and body.

Connector & Terminal/Specified voltage:

- (E15) No. 2 — Body/10 V, min.
- (E6) No. 2 — Body/10 V, min.
- (E16) No. 2 — Body/10 V, min.
- (E7) No. 2 — Body/10 V, min.

3. CHECK FUEL INJECTORS.

- 1) Disconnect connector from injector.
- 2) Measure resistance between injector terminals.

Specified resistor:

11 ~ 12 Ω

4. CHECK VOLTAGE AT EACH ECU TERMINAL.

Measure voltage between each fuel injector terminal of ECU connector and body.

(Fuel injector connector is connected.)

Connector & Terminal/Specified voltage:

- (B125) No. 11 — Body/10 V, min.
- (B125) No. 12 — Body/10 V, min.
- (B125) No. 13 — Body/10 V, min.
- (B125) No. 26 — Body/10 V, min.

5. CHECK HARNESS CONNECTOR BETWEEN ECU AND BODY.

- 1) Disconnect connector from ECU.
- 2) Measure resistance between ECU connector and body.

Connector & Terminal/Specified resistance:

- (B125) No. 24 — Body/0 Ω
- (B125) No. 25 — Body/0 Ω

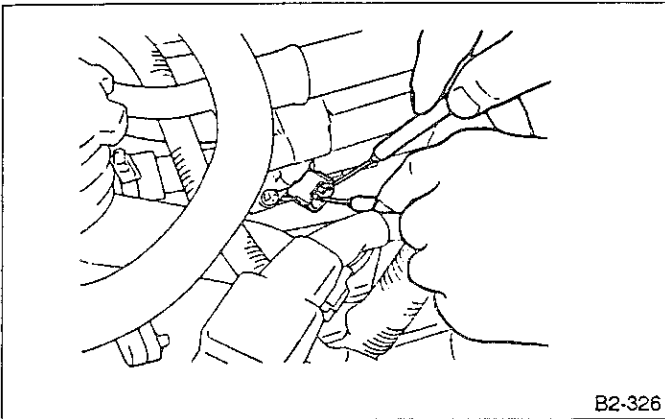


Fig. 50

E: TROUBLE CODE (21) — WATER TEMPERATURE SENSOR —

CONTENT OF DIAGNOSIS:
Abnormal signal emitted from water temperature sensor

TROUBLE SYMPTOM:

- Hard to start
- Erroneous idling
- Poor driving performance

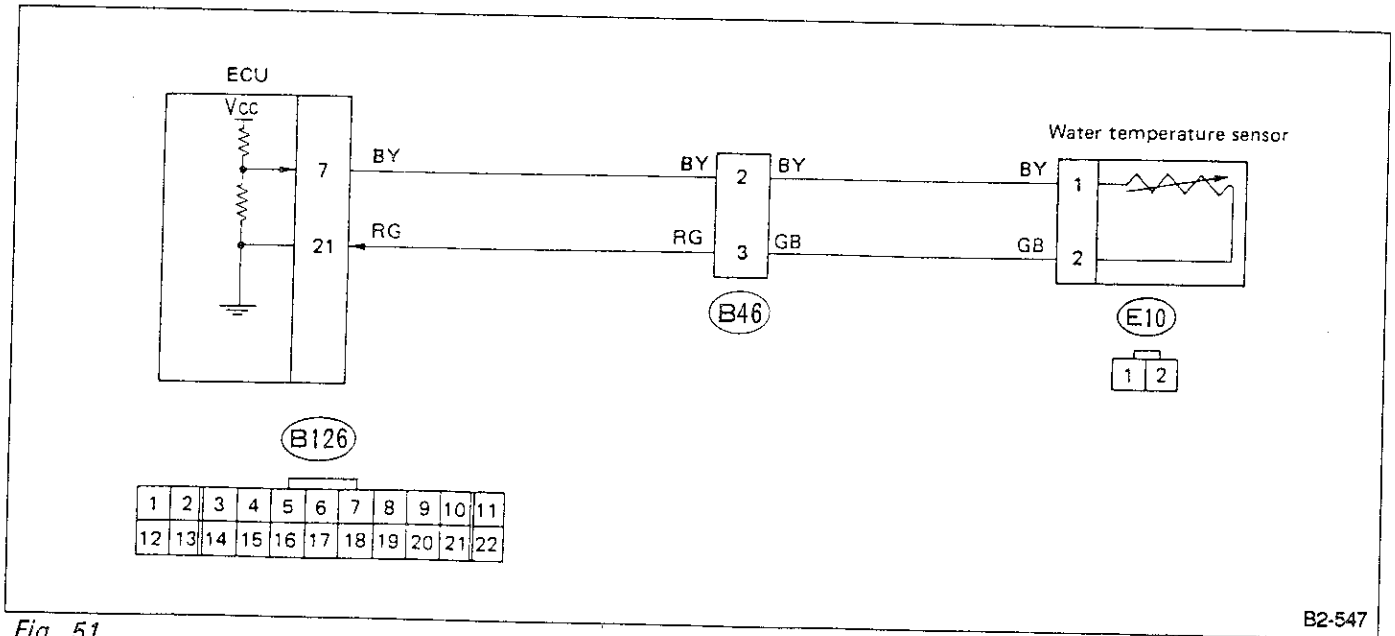
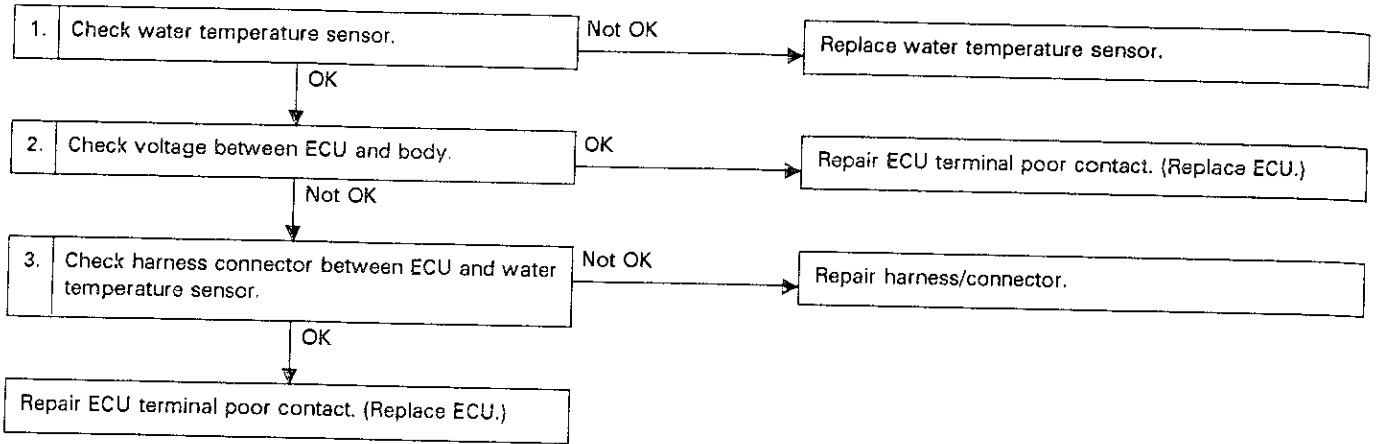


Fig. 51

B2-547

1. CHECK WATER TEMPERATURE SENSOR.

- 1) Disconnect connector from water temperature sensor.
- 2) Measure resistance between water temperature sensor terminals.

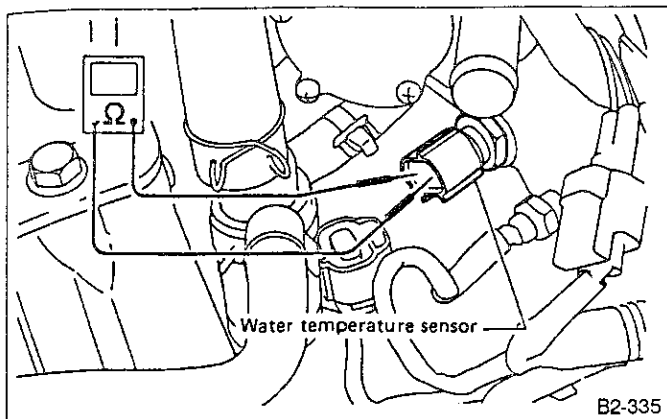


Fig. 52

Specified resistance:

- 2.0 — 3.0 k Ω [20°C (68°F)]
- 0.3 — 0.4 k Ω [80°C (176°F)]

2. CHECK VOLTAGE BETWEEN ECU AND BODY.

- 1) Connect water temperature sensor connector.
- 2) Turn ignition switch to "ON".
- 3) Measure voltage between ECU connector terminal and body.

Connector & Terminal/Specified voltage:

- (B48) No. 7 — Body/0.6 — 4.5 V

3. CHECK HARNESS CONNECTOR BETWEEN ECU AND WATER TEMPERATURE SENSOR.

- 1) Disconnect ECU connector and water temperature sensor connector.
- 2) Measure resistance between ECU connector and water temperature connector.

Connector & Terminal/Specified resistance:

- (B48) No. 7 — (E7) No. 1/0 Ω
- (B48) No. 21 — (E7) No. 2/0 Ω

- 3) Measure resistance between water temperature sensor connector and body.

Connector & Terminal/Specified resistance:

- (E7) No. 1 — Body/1 M Ω min.
- (E7) No. 2 — Body/1 M Ω min.

• SELECT MONITOR FUNCTION MODE

Mode: F06

Condition:

After warming up engine, engine at idle and radiator fan OFF.

Specified Data: TW F06
80 — 95 deg C

F05 = Water temperature signal (TW): To be indicated in "deg F"

F: TROUBLE CODE (22) — KNOCK SENSOR (2200 cc model only) —

CONTENT OF DIAGNOSIS:
Abnormal voltage produced in knock sensor

TROUBLE SYMPTOM:
Poor driving performance

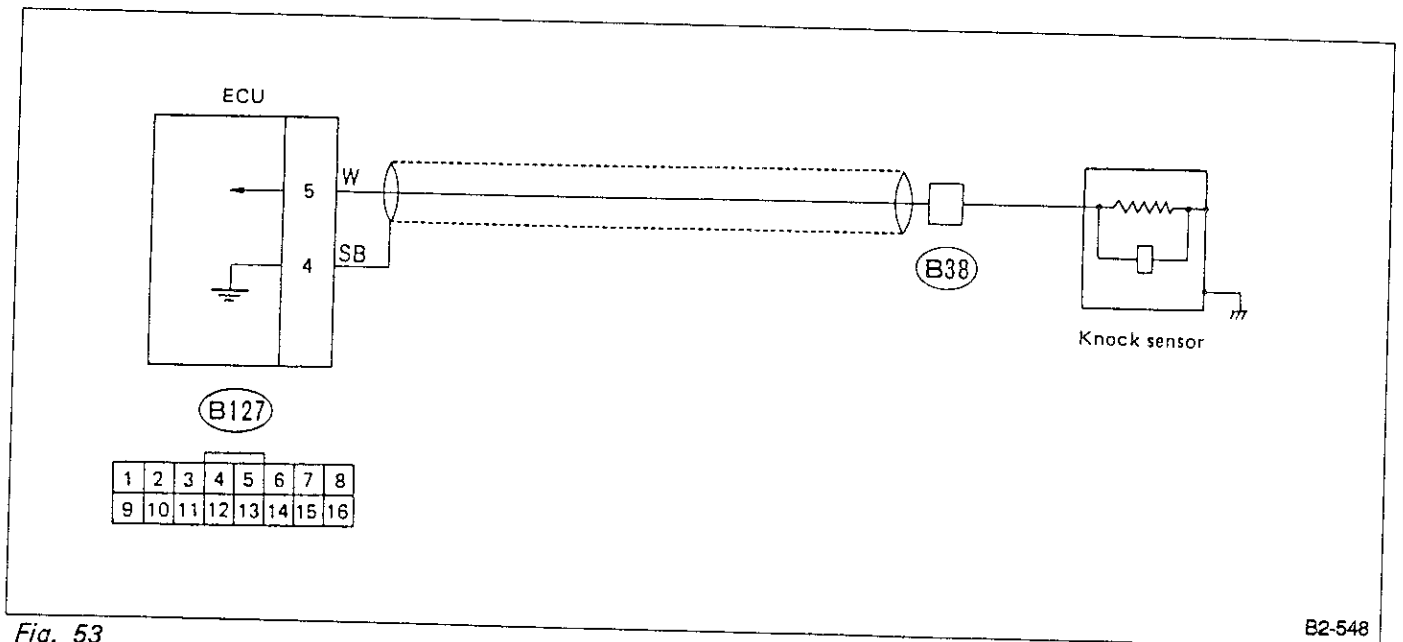
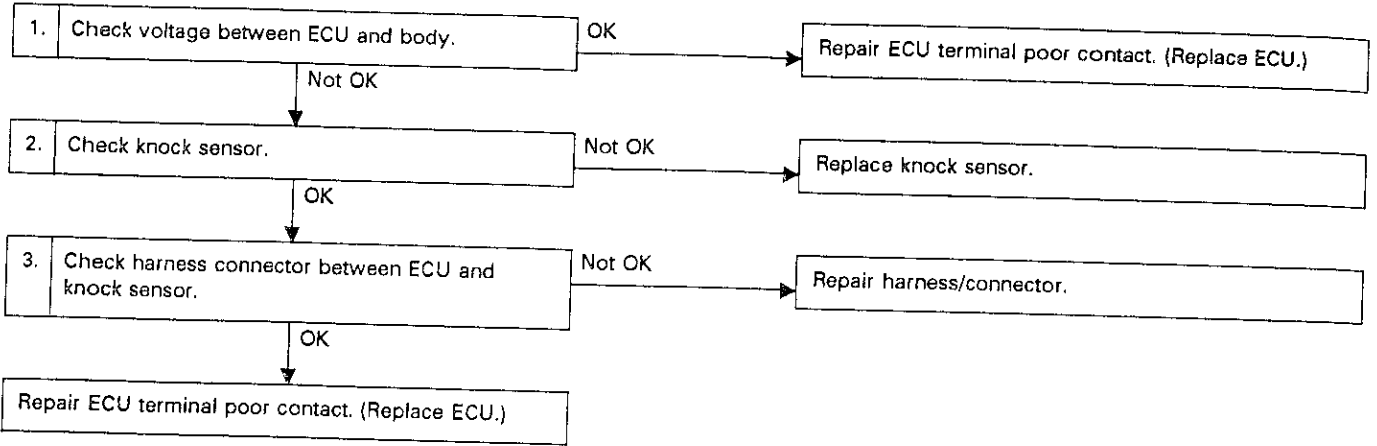


Fig. 53

B2-548

1. CHECK VOLTAGE BETWEEN ECU AND BODY.

- 1) Turn ignition switch to "ON".
- 2) Measure voltage between ECU connector terminal and body.

Connector & Terminal/Specified voltage:
(B127) No. 5 — Body/3 — 4 V

2. CHECK KNOCK SENSOR.

- 1) Disconnect connector from knock sensor.
- 2) Measure resistance between knock sensor terminals and body.

Specified resistance:
Approx. 560 k Ω

3. CHECK HARNESS CONNECTOR BETWEEN ECU AND KNOCK SENSOR.

- 1) Disconnect connectors from ECU and knock sensor.
- 2) Measure resistance between ECU and knock sensor connectors.

Connector & Terminal/Specified resistance:
(B127) No. 5 — (B38) No. 1/0 Ω

- 3) Measure resistance between knock sensor connector and body.

Connector & Terminal/Specified resistance:
(B38) No. 1 — Body/1 M Ω min.

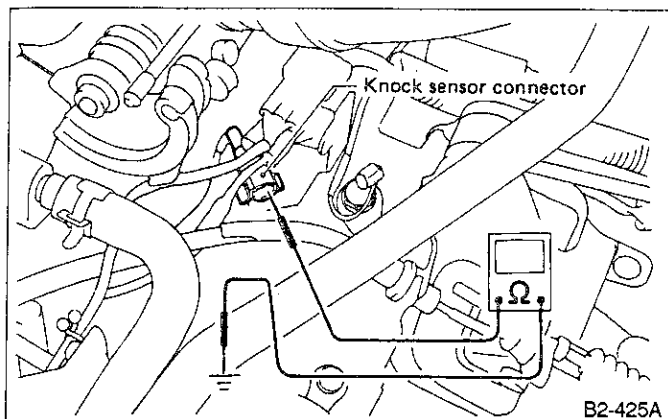


Fig. 54

G: TROUBLE CODE (23) — AIR FLOW SENSOR —

CONTENT OF DIAGNOSIS:
Abnormal voltage input entered from air flow sensor

- TROUBLE SYMPTOM:**
- Erroneous idling
 - Engine stall
 - Poor driving performance

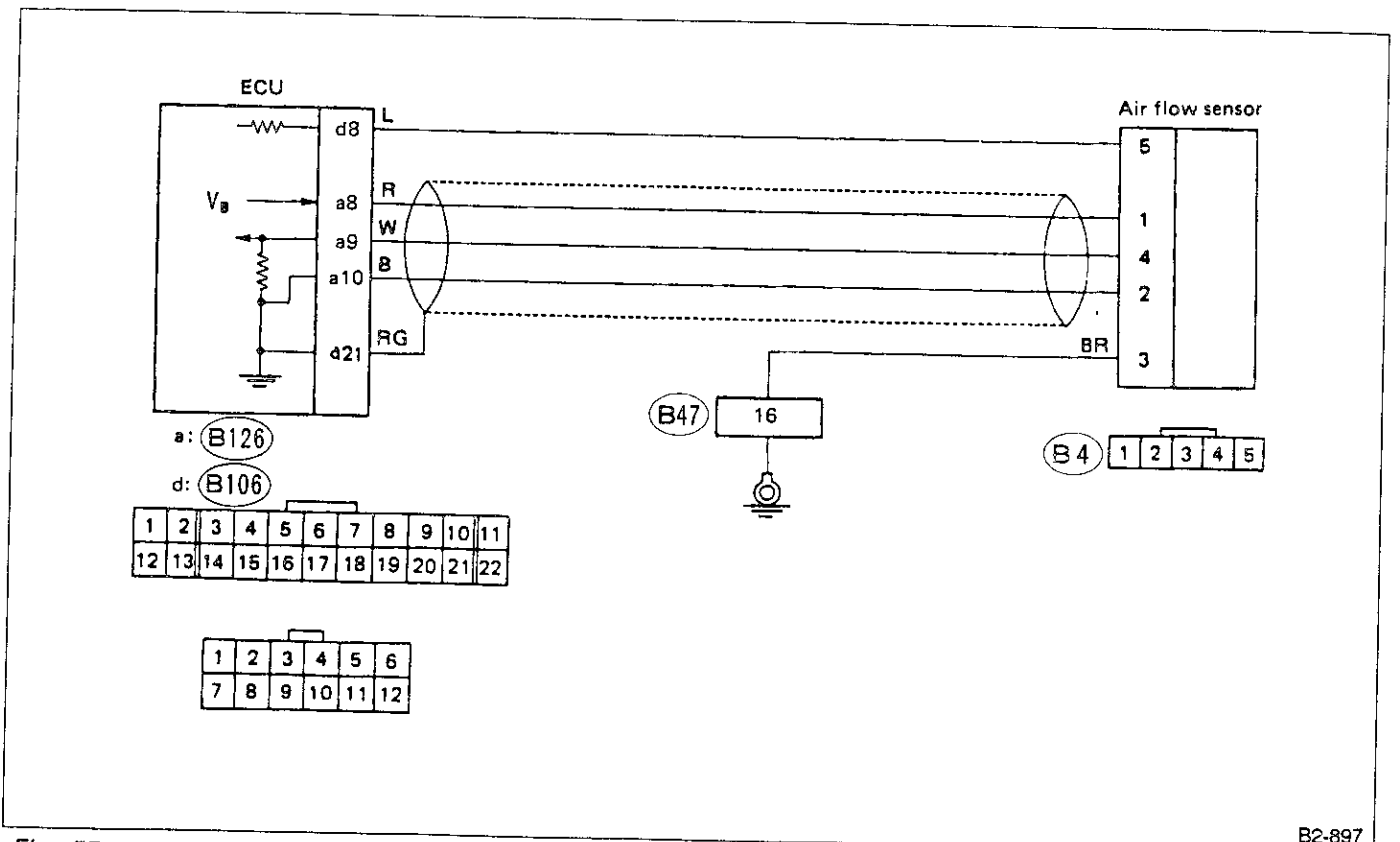
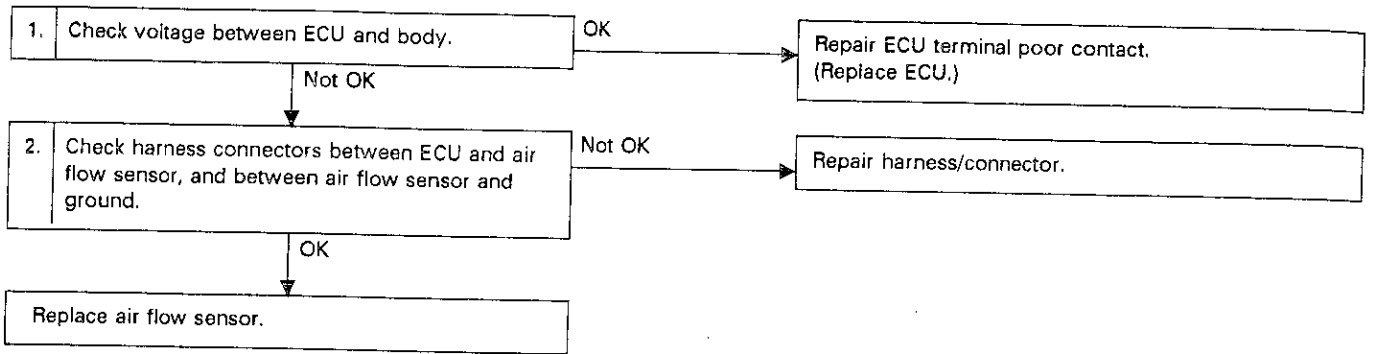


Fig. 55

B2-897

1. CHECK VOLTAGE BETWEEN ECU AND BODY.

- 1) Turn ignition switch to "ON".
- 2) Measure voltage between ECU connector terminal and body.

Connector & Terminal/Specified voltage:

- (B126) No. 8 — Body/
 10 — 13 V (Engine OFF)
 13 — 14 V (Engine at idle)
- (B126) No. 9 — Body/
 0 — 0.3 V (Engine OFF)
 0.8 — 1.2 V (Engine at idle)
- (B126) No. 10 — Body/
 0 V (Engine OFF)
 0 V (Engine at idle)

• SELECT MONITOR FUNCTION MODE

Mode: F08

Condition: Engine at idle

Specified Data: QA F08

0.8 — 1.2 V

2. CHECK HARNESS CONNECTOR BETWEEN ECU AND AIR FLOW SENSOR.

- 1) Disconnect ECU and air flow sensor connectors.
- 2) Measure resistance between ECU and air flow sensor connectors.

Connector & Terminal/Specified resistance:

- (B126) No. 8 — (B4) No. 1/0 Ω
- (B126) No. 9 — (B4) No. 4/0 Ω
- (B126) No. 10 — (B4) No. 2/0 Ω

- 3) Measure resistance between air flow sensor connector and body.

Connector & Terminal/Specified resistance:

- (B4) No. 1 — Body/1 M Ω min.
- (B4) No. 4 — Body/1 M Ω min.
- (B4) No. 2 — Body/1 M Ω min.
- (B4) No. 3 — Body/0 Ω

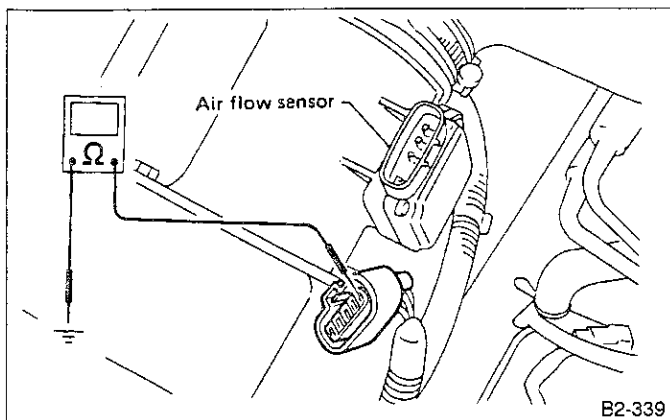


Fig. 56

H: TROUBLE CODE (24) — BY-PASS AIR CONTROL SOLENOID VALVE --

CONTENT OF DIAGNOSIS:
Solenoid valve inoperative

TROUBLE SYMPTOM:

- Erroneous idling
- Engine stall
- Engine breathing

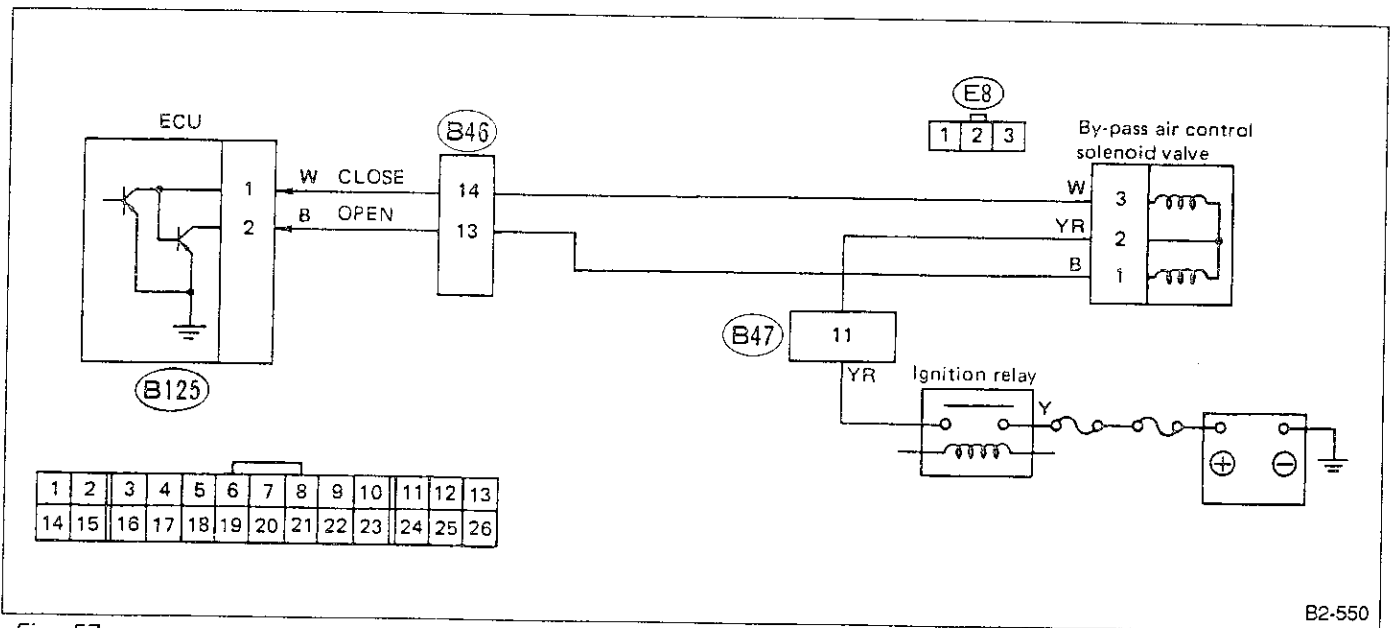
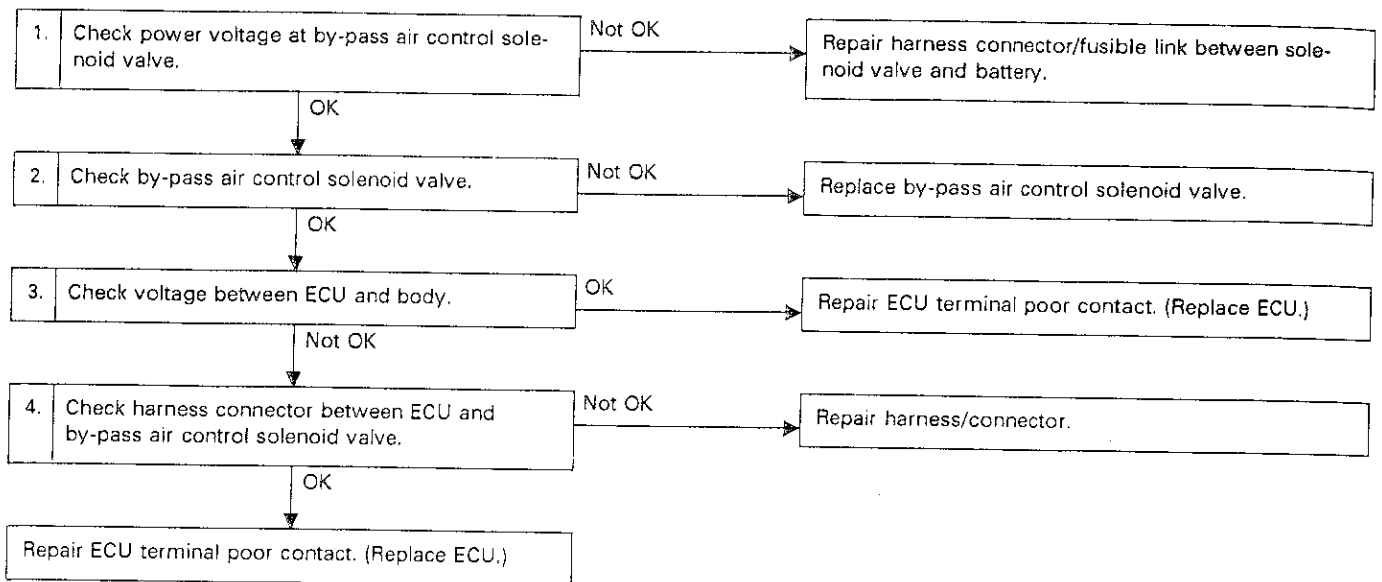


Fig. 57

1. CHECK POWER VOLTAGE AT BY-PASS AIR CONTROL SOLENOID VALVE.

- 1) Turn ignition switch to "ON".
- 2) Measure voltage between air control valve connector terminal and body.

Connector & Terminal/Specified voltage:
(E8) No. 2 — Body/10 V, min.

2. CHECK BY-PASS AIR CONTROL SOLENOID VALVE.

- 1) Disconnect connector from solenoid valve.
- 2) Measure resistance between solenoid valve terminals.

Connector & Terminal/Specified resistance:
No. 1 — No. 2/9 Ω
No. 2 — No. 3/9 Ω

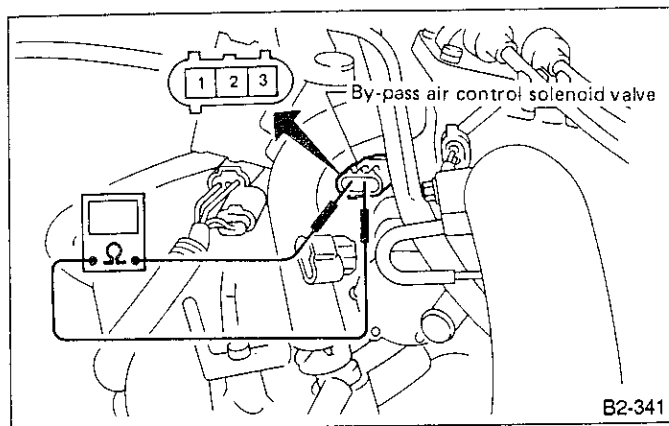


Fig. 58

3. CHECK VOLTAGE BETWEEN ECU AND BODY.

- 1) Turn ignition switch to "ON".
- 2) Measure voltage between ECU connector terminal and body.

Connector & Terminal/Specified voltage:
(B125) No. 2 — Body/8 — 9 V
(B125) No. 1 — Body/6 — 7 V

4. CHECK HARNESS CONNECTOR BETWEEN ECU AND BY-PASS AIR CONTROL SOLENOID VALVE.

- 1) Disconnect connectors from ECU and air control valve.
- 2) Measure resistance between ECU connector and control valve connector.

Connector & Terminal/Specified resistance:
(B125) No. 2 — (E8) No. 1/0 Ω
(B125) No. 1 — (E8) No. 3/0 Ω

- 3) Measure resistance between solenoid valve connector and body.

Connector & Terminal/Specified resistance:
(E8) No. 1 — Body/1 MΩ min.
(E8) No. 3 — Body/1 MΩ min.

• **SELECT MONITOR FUNCTION MODE**

Mode: F12
Condition: Engine at idle
Specified Data: ISC F12
30 — 40%

I: TROUBLE CODE (31) — THROTTLE SENSOR —

CONTENT OF DIAGNOSIS:

Abnormal voltage input entered from throttle sensor.

TROUBLE SYMPTOM:

- Erroneous idling
- Engine stall
- Poor driving performance

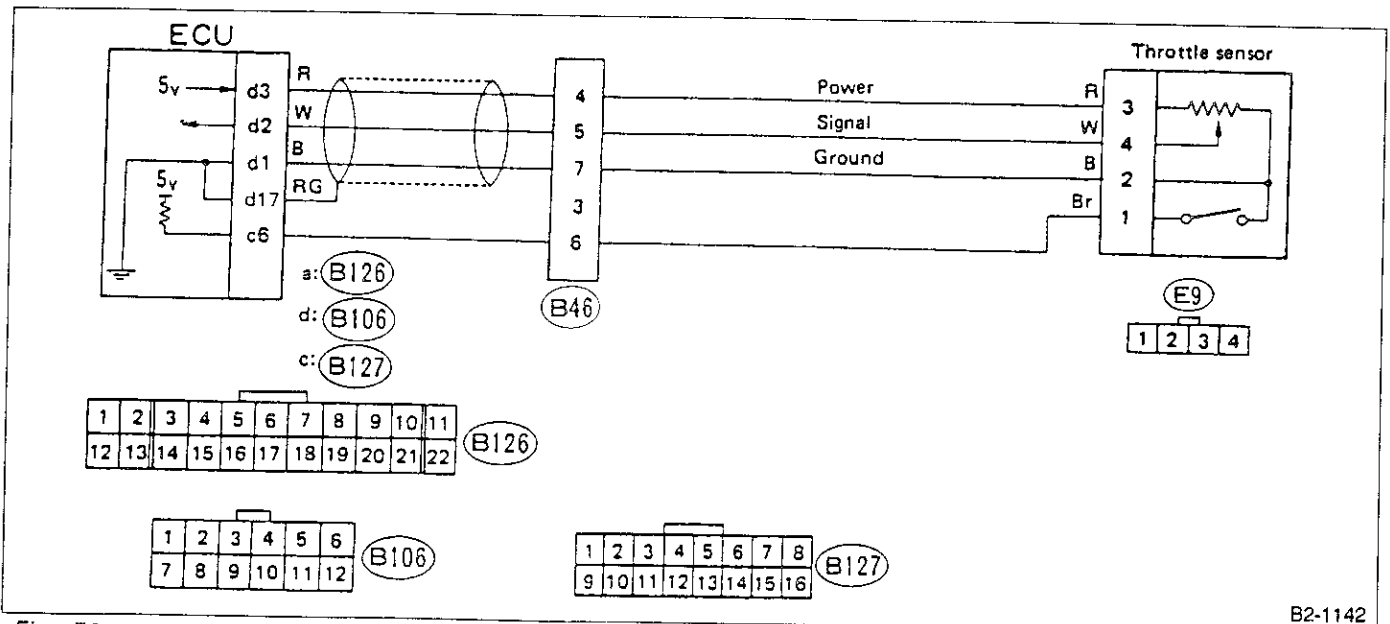
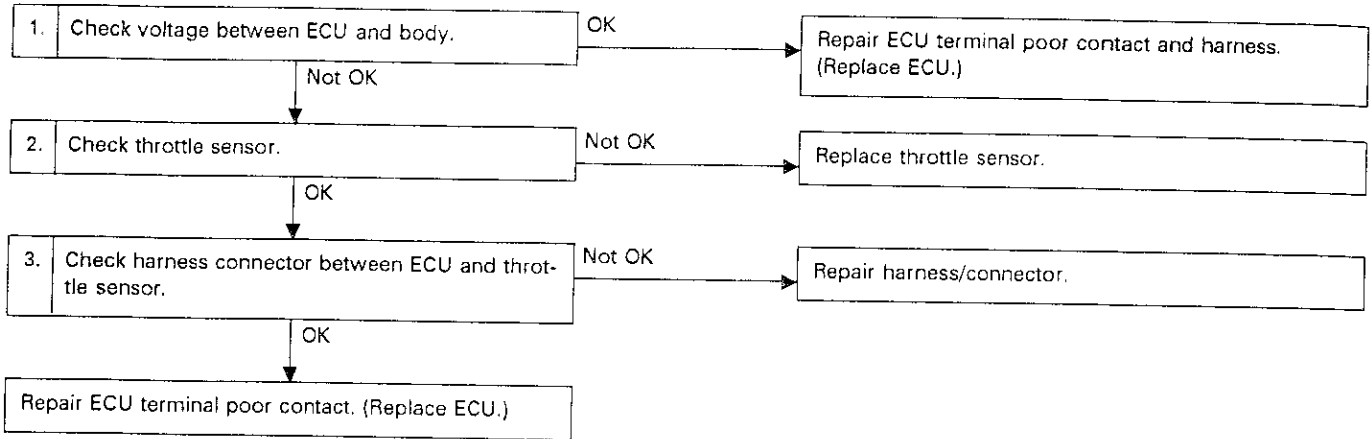


Fig. 59

B2-1142

1. CHECK VOLTAGE BETWEEN ECU AND BODY.

- 1) Turn ignition switch to "ON".
- 2) Measure voltage between ECU connector terminal and body.

Connector & Terminal/Specified voltage:

- (B106) No. 2 — Body/
4.4 — 4.3 V (Throttle is fully closed.)
0.7 — 1.6 V (Throttle is fully open.)
(Ensure voltage smoothly decreases as throttle valve changes from "closed" to "open".)
- (B106) No. 3 — Body/5 V
- (B106) No. 1 — Body/0 V

2. CHECK THROTTLE SENSOR.

- 1) Disconnect connector from throttle sensor.
- 2) Measure resistance between throttle sensor terminals.

Connector & Terminal/Specified resistance:

- No. 2 — No. 3/12 kΩ

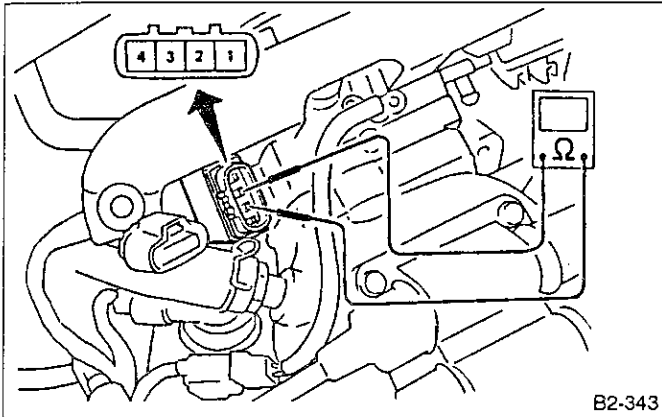


Fig. 60

- 3) Measure resistance between terminals while slowly opening throttle valve from the "closed" position.

Terminal/Specified resistance:

- No. 2 — No. 4/ 10 — 12 kΩ (Throttle is fully closed.)
 - 3 — 5 kΩ (Throttle is fully open.)
- Ensure resistance increases in response to throttle valve opening.

3. CHECK HARNESS CONNECTOR BETWEEN ECU AND THROTTLE SENSOR.

- 1) Disconnect connectors from ECU and throttle sensor.
- 2) Measure resistance between ECU connector and throttle sensor connectors.

Connector & Terminal/Specified resistance:

- (B106) No. 1 — (E9) No. 2 / 0 Ω
- (B106) No. 2 — (E9) No. 4 / 0 Ω
- (B106) No. 3 — (E9) No. 3 / 0 Ω

- 3) Measure resistance between throttle sensor connector and body.

Connector & Terminal/Specified resistance:

- (E9) No. 2 — Body/1 MΩ min.
- (E9) No. 4 — Body/1 MΩ min.
- (E9) No. 3 — Body/1 MΩ min.

• SELECT MONITOR FUNCTION MODE

Mode: F10

Condition: ignition switch ON and throttle valve fully closed and open

Specified Data: THV F10

- 4.7 V (Throttle valve fully closed)
- 0.9 V (Throttle valve fully open)

J: TROUBLE CODE (32) — O₂ SENSOR (Catalyst model only) —

CONTENT OF DIAGNOSIS:
O₂ sensor inoperative

- TROUBLE SYMPTOM:
- Failure of engine to start
 - Erroneous idling
 - Poor driving performance
 - Engine stall

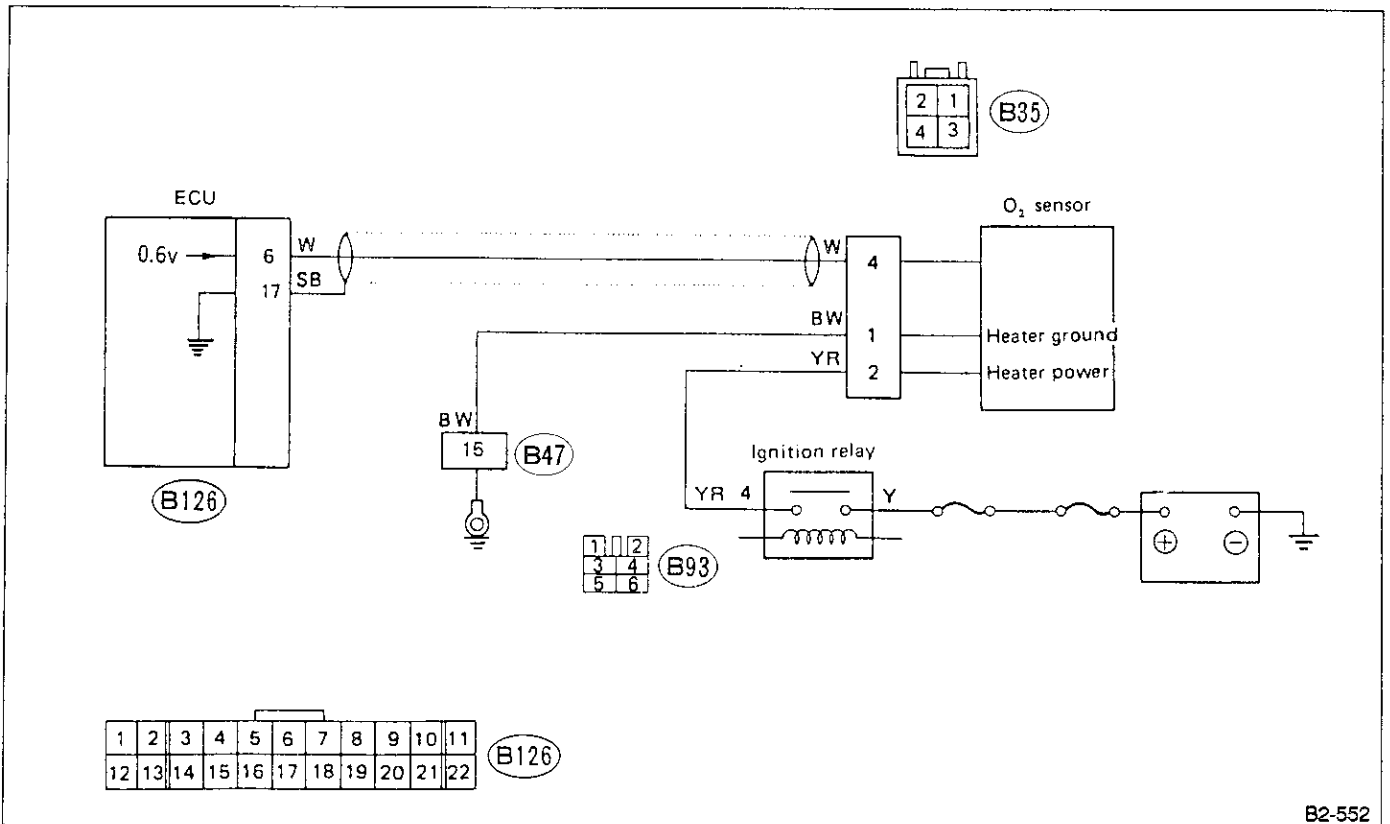
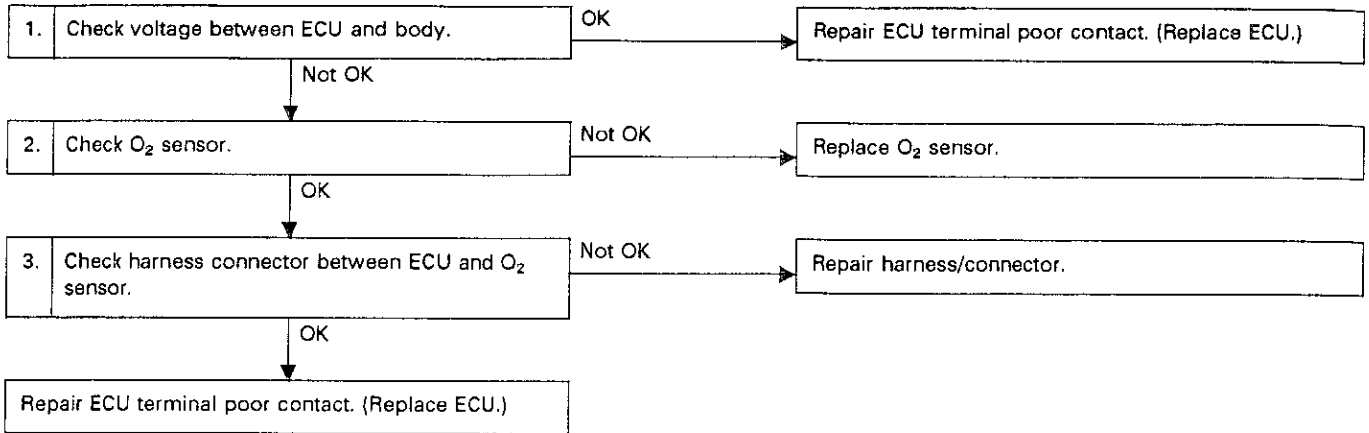


Fig. 61

B2-552

1. CHECK VOLTAGE BETWEEN ECU AND BODY.

Measure voltage between ECU connector terminal and body while idling engine.

Connector & Terminal/Specified voltage:
(B126) No. 6 — Body/0.1 — 0.9 V

Problems in heater circuit causes O₂ sensor to deactivate.

2. CHECK O₂ SENSOR.

- 1) Idle engine.
- 2) Disconnect O₂ sensor connector.
- 3) Measure voltage between O₂ sensor terminal and body.

Connector & Terminal/Specified voltage:
No. 4 — Body/0.1 — 0.9 V

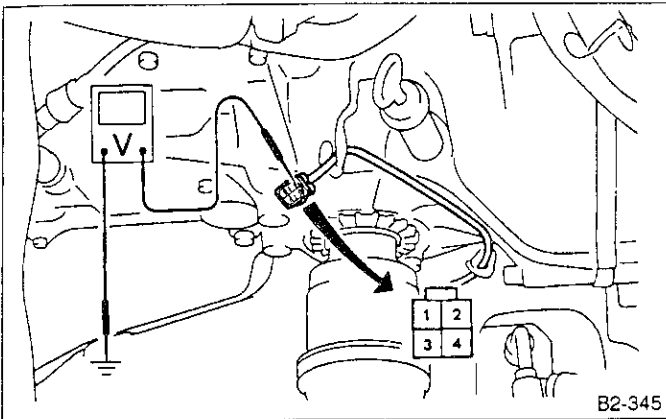


Fig. 62

3. CHECK HARNESS CONNECTOR BETWEEN ECU AND O₂ SENSOR.

- 1) Disconnect connectors from ECU and O₂ sensor.
- 2) Measure resistance between ECU connector and O₂ sensor connector.

Connector & Terminal/Specified resistance:
(B126) No.6 — (B35) No. 4/0 Ω

- 3) Measure resistance between O₂ sensor connector and body.

Connector & Terminal/Specified resistance:
(B35) No. 4 — Body /1 MΩ min.

• SELECT MONITOR FUNCTION MODE

Mode: F13, F15, F16

Condition : After driving at more than 7 MPH for at least one minute with engine warmed up.

Specified Data:	F02	F13
	0.1 — 0.9 V	
	0.2 max	F15
	0.7 — 1.0 V	
	0.2 min	F16
	0 — 0.2 V	

K: TROUBLE CODE (33) — VEHICLE SPEED SENSOR 2 —

CONTENT OF DIAGNOSIS:
Abnormal voltage input entered from vehicle speed sensor 2

TROUBLE SYMPTOM:

- Erroneous idling
- Engine stall
- Poor driving performance

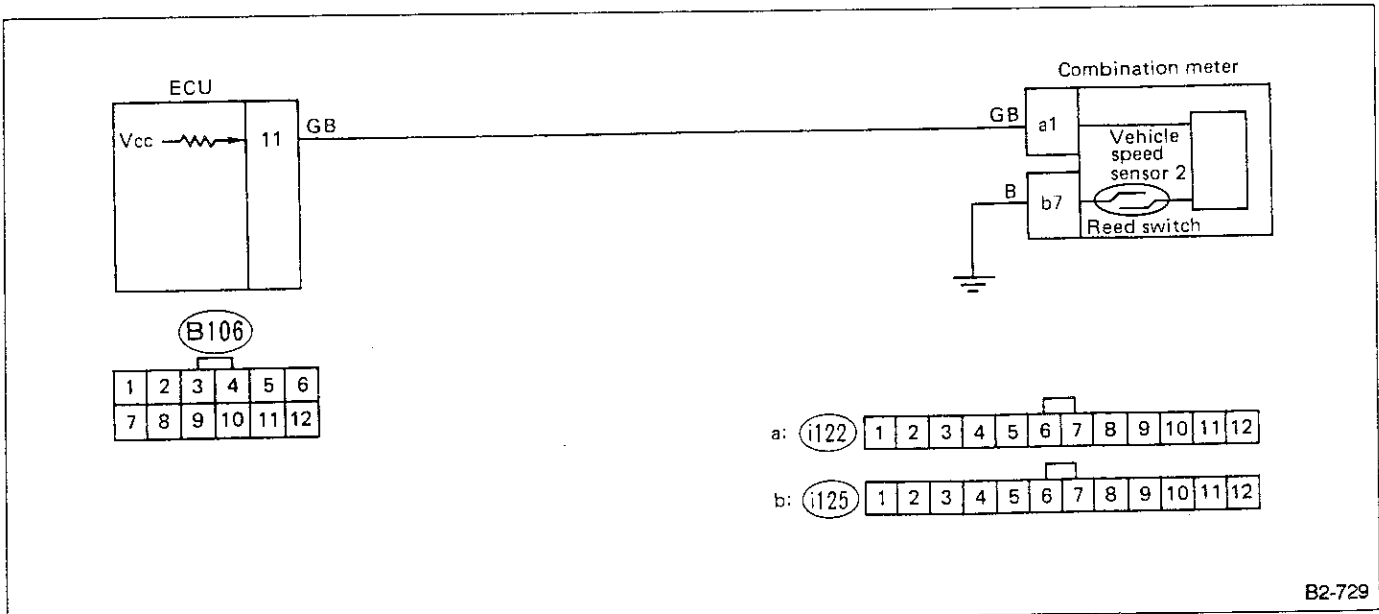
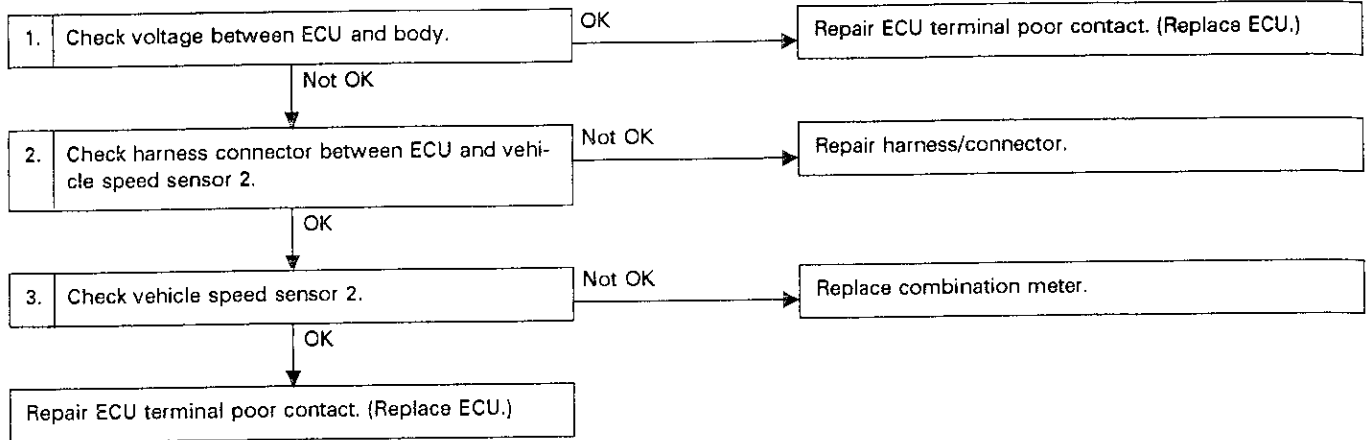


Fig. 63

1. CHECK VOLTAGE BETWEEN ECU AND BODY.

- 1) Raise vehicle and support with safety stands. Ensure all four wheels are off the ground (4WD model).
- 2) Measure voltage between ECU connector terminal and body while slowly driving wheels.

Connector & Terminal/Specified voltage:
(B106) No. 11 — Body/0 ↔ 5 V

2. CHECK HARNESS CONNECTOR BETWEEN ECU AND VEHICLE SPEED SENSOR 2.

- 1) Remove connector from ECU and combination meter.
- 2) Measure resistance between ECU connector and combination meter connector.

Connector & Terminal/Specified resistance:
(B106) No. 11 — (i22) No. 1/0 Ω

- 3) Measure resistance between combination meter connector and body.

Connector & Terminal/Specified resistance:
(i22) No. 1 — Body/1 MΩ min.
(i25) No. 7 — Body/ 0 Ω

3. CHECK VEHICLE SPEED SENSOR 2.

- 1) Remove combination meter.
- 2) Disconnect connectors from combination meter.
- 3) Insert a screwdriver into hole normally occupied by meter cable and rotate rotor.
- 4) Check that resistance across combination meter terminals changes four times per gear rotation.

Connector & Terminal/Specified resistance:
(i13) No. 1 — (i16) No. 7/0 ↔ 1 MΩ min.

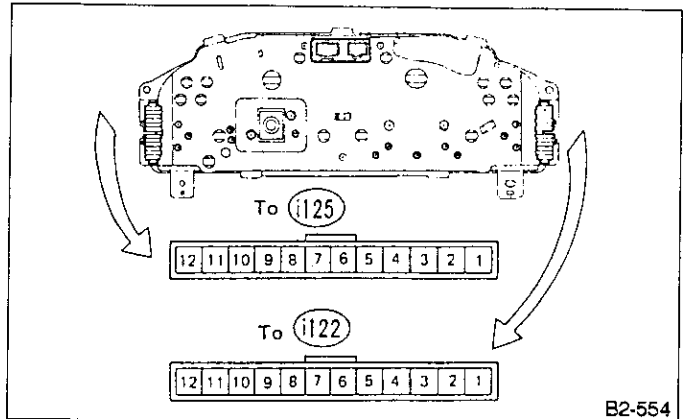


Fig. 64

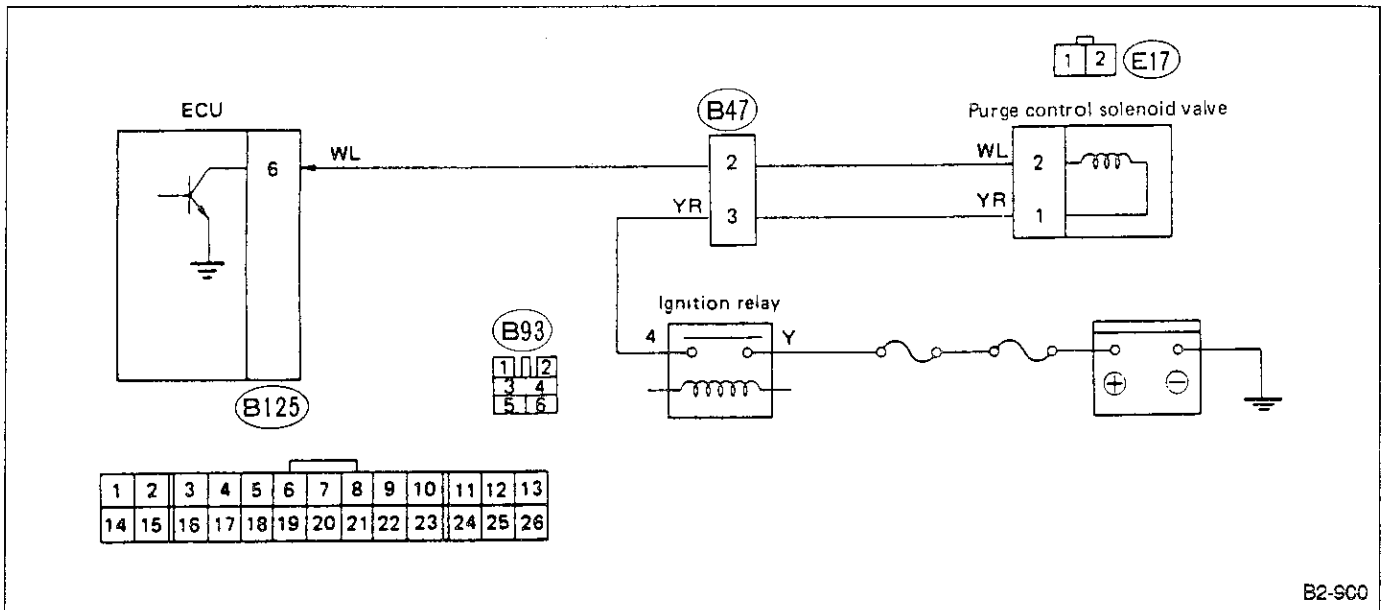
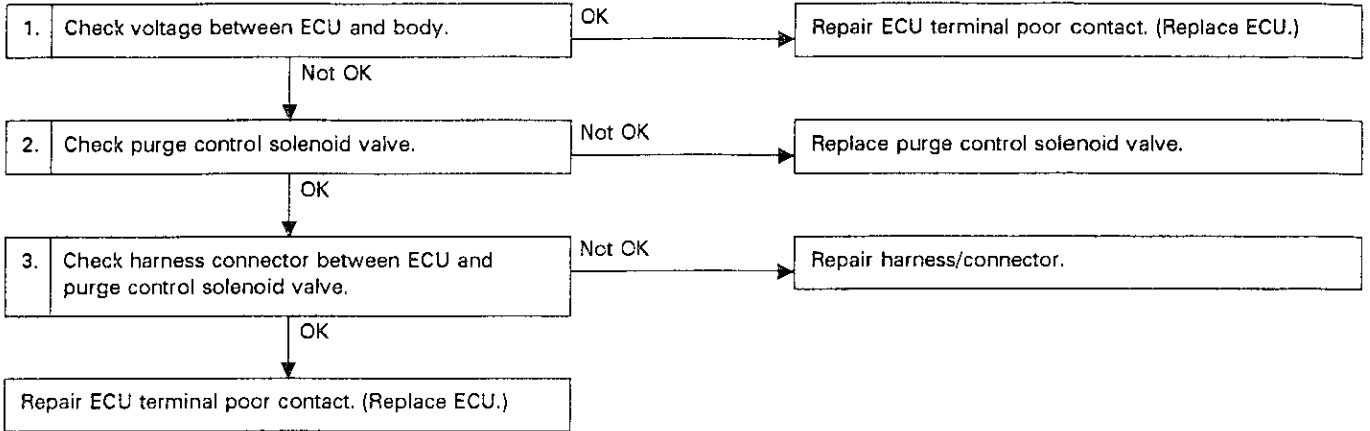
• **SELECT MONITOR FUNCTION MODE**

Mode: F03
Condition: While driving vehicle
Specified data: VSP F03
(Car speed) km/h

L: TROUBLE CODE (35) — PURGE CONTROL SOLENOID VALVE --

CONTENT OF DIAGNOSIS:
Solenoid valve inoperative

TROUBLE SYMPTOM:
● Erroneous idling



B2-900

Fig. 65

1. CHECK VOLTAGE BETWEEN ECU AND BODY.

- 1) Turn ignition switch to "ON" with engine OFF.
- 2) Measure voltage between ECU connector terminal and body.

Connector & Terminal/Specified voltage:
(B125) No. 6 — Body/10 — 13 V

2. CHECK PURGE CONTROL SOLENOID VALVE.

- 1) Disconnect connector from solenoid valve.
- 2) Measure resistance between solenoid valve terminals.

Specified resistance:
35.5 Ω (at 20°C)

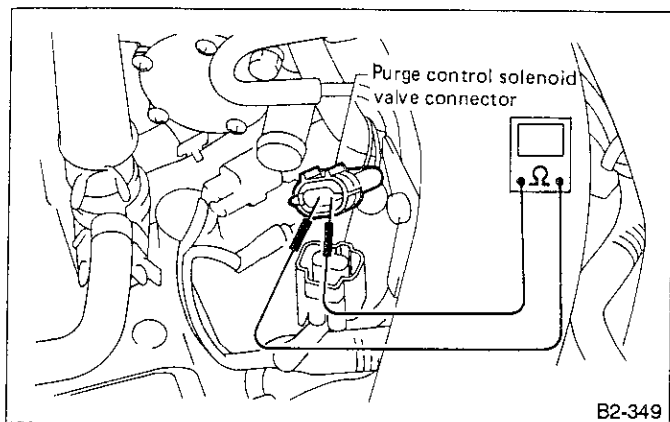


Fig. 66

3. CHECK HARNESS CONNECTOR BETWEEN ECU AND PURGE CONTROL SOLENOID VALVE.

- 1) Disconnect connectors from ECU and solenoid valve.
- 2) Measure resistance between ECU connector and solenoid valve connector.

Connector & Terminal/Specified resistance:
(B125) No. 6 — (E17) No. 2/0 Ω

- 3) Measure resistance between solenoid valve connector and body.

Connector & Terminal/Specified resistance:
(E17) No. 2 — Body/1 MΩ min.

- 4) Disconnect ground and positive terminals from battery in that order.

- 5) Measure resistance between solenoid connector and battery's positive terminal.

Connector & Terminal/Specified resistance:
(E17) No. 1 — (+) terminal/0 Ω

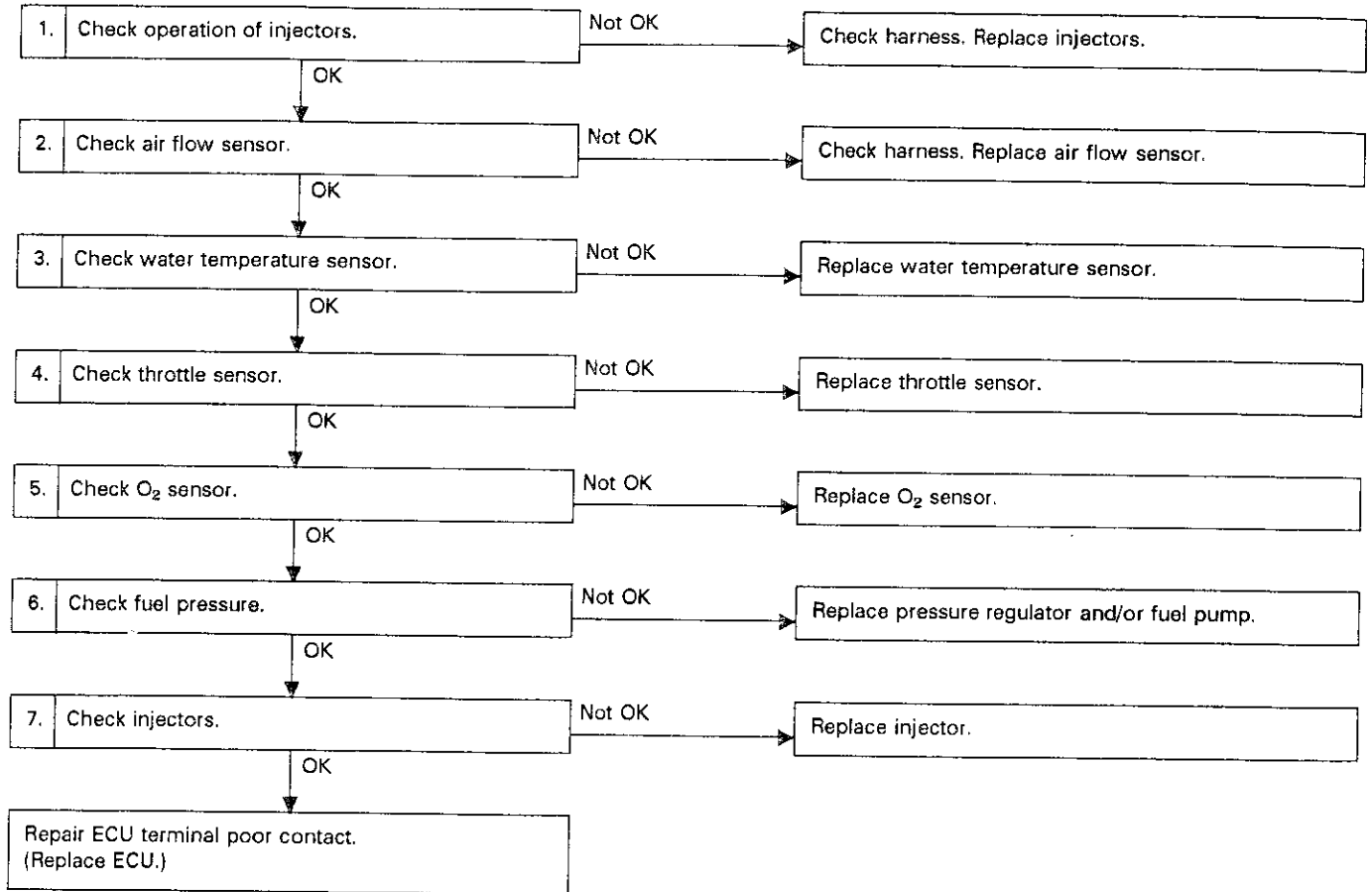
• SELECT MONITOR FUNCTION MODE

Mode: FA1
LED No.: 7
ON/OFF Signal: LED OFF (Solenoid OFF)
LED ON (Solenoid ON)

M: TROUBLE CODE (41) — AIR-FUEL RATIO CONTROL SYSTEM —

CONTENT OF DIAGNOSIS:
Faulty learning control system

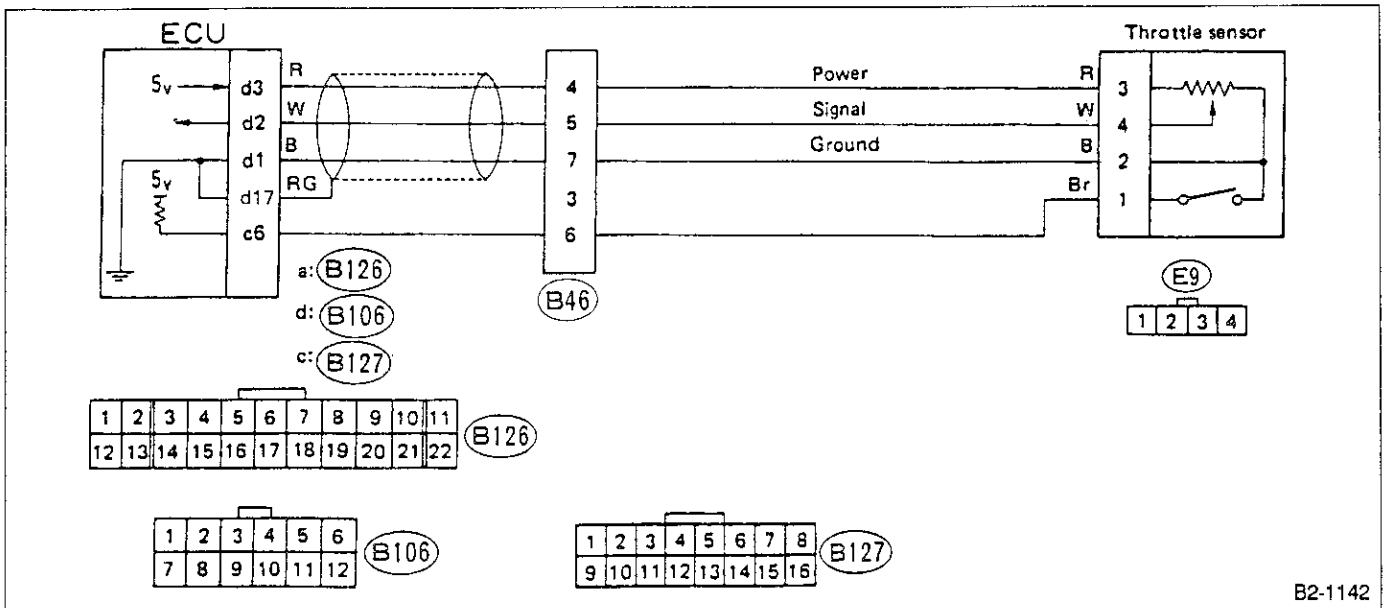
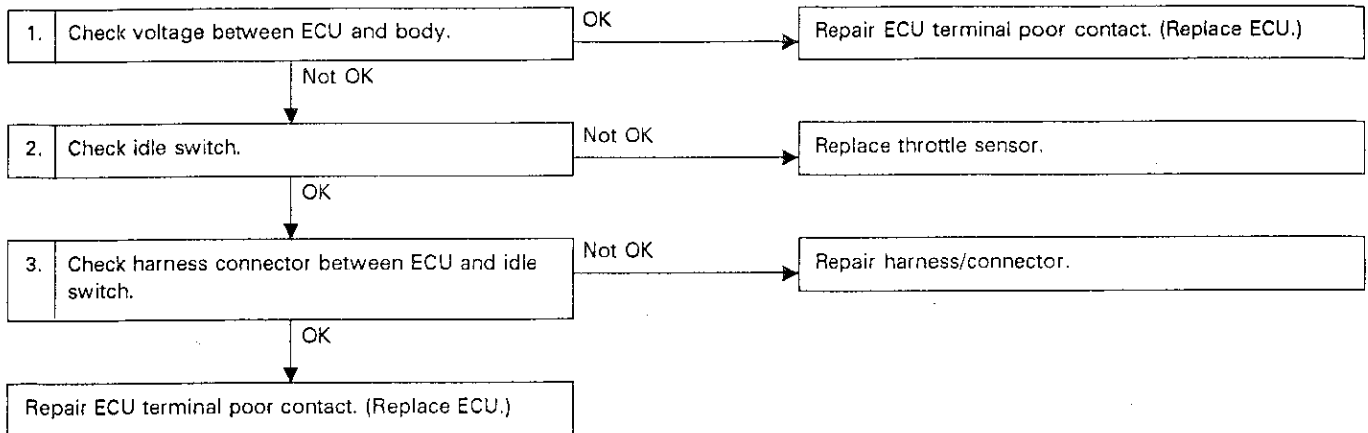
TRouble SYMPTOM:
 • Erroneous idling
 • Engine stall



N: TROUBLE CODE (42) — IDLE SWITCH —

CONTENT OF DIAGNOSIS:
Abnormal voltage input entered from idle switch

TROUBLE SYMPTOM:
 • Erroneous idling
 • Engine stall
 • Poor driving performance



B2-1142

Fig. 67

1. CHECK VOLTAGE BETWEEN ECU AND BODY.

- 1) Turn ignition switch to "ON".
- 2) Measure voltage between ECU connector terminal and body.

Connector & Terminal/Specified voltage:
 (B127) No. 6 — Body/0 V (Throttle is fully closed.)
 Approx. 5 V (Throttle is open.)

2. CHECK IDLE SWITCH.

- 1) Disconnect connector from throttle sensor.
- 2) Check continuity between throttle sensor idle switch terminals.

Terminal/Specified resistance:
 No. 1 — No. 2 /0 Ω (Throttle is fully closed.)
 1 M Ω min. (Throttle is fully open.)

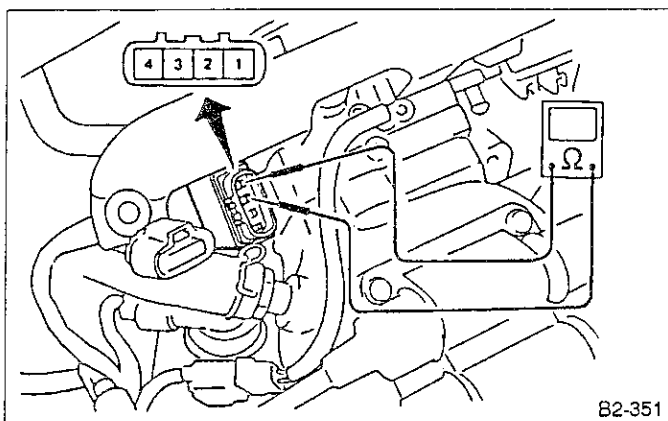


Fig. 68

3. CHECK HARNESS CONNECTOR BETWEEN ECU AND IDLE SWITCH.

- 1) Disconnect connectors from ECU and throttle sensor.
- 2) Measure resistance between ECU connector and throttle sensor connector.

Connector & Terminal/Specified resistance:
 (B127) No. 6 — (E9) No. 1/0 Ω
 (B106) No. 1 — (E9) No. 2/0 Ω

- 3) Measure resistance between throttle sensor connector and body.

Connector & Terminal/Specified resistance:
 (E9) No. 1 — Body/1 M Ω min.
 No. 2 — Body/1 M Ω min.

• SELECT MONITOR FUNCTION MODE

Mode: FA1
 LED No.: 1

Condition: Ignition switch ON
 ON/OFF Signal:
 LED OFF (Idle switch OFF)
 LED ON (Idle switch ON)

O: TROUBLE CODE (49) — AIR FLOW SENSOR —

CONTENT OF DIAGNOSIS:
Use of improper air flow sensor

TROUBLE SYMPTOM:
● Erroneous idling
● Failure of engine to start

When trouble code 49 appears on display, check the specifications of air flow sensor and ECU. Replace air flow sensor (or ECU) with one of a proper type.

P: TROUBLE CODE (47) — ECONOMY SWITCH (AT) —

CONTENT OF DIAGNOSIS:
Abnormal signal entered from economy switch

TRUBLE SYMPTOM:
Improper shift point

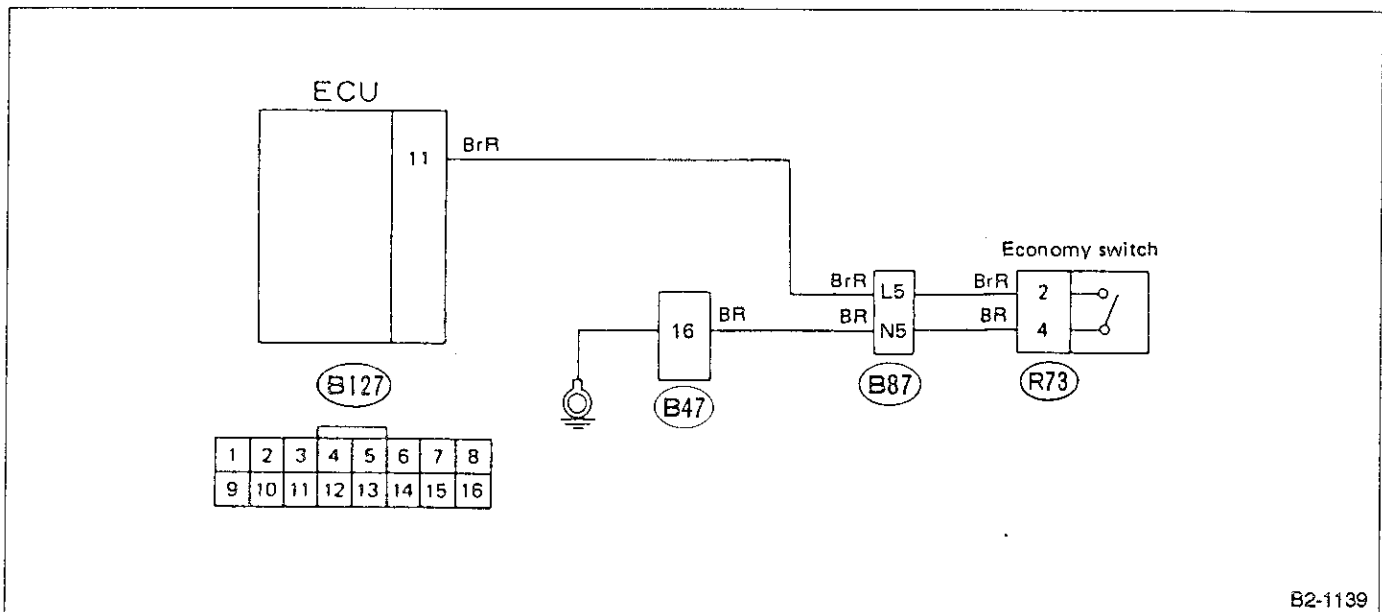
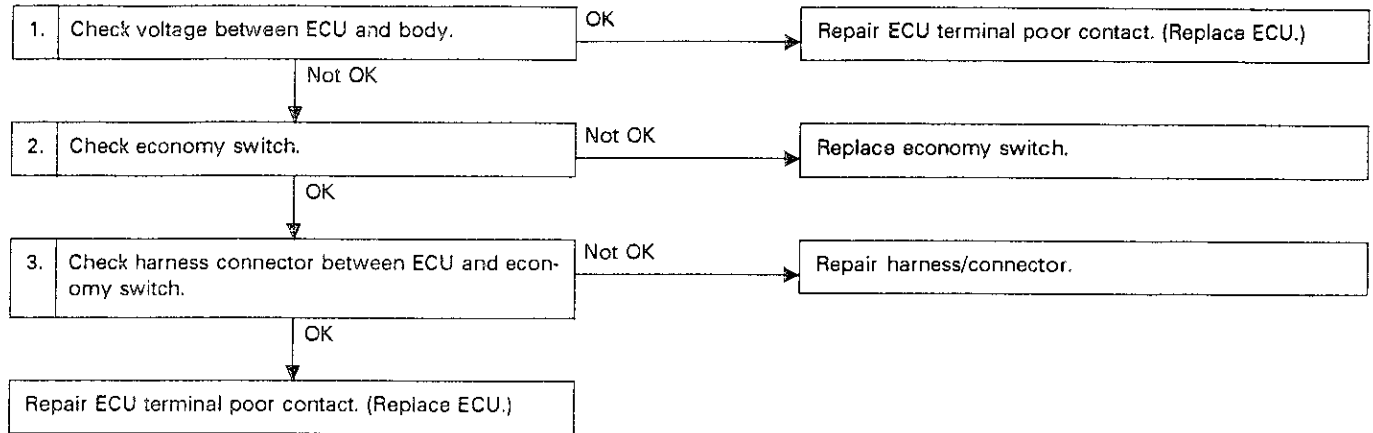


Fig. 69

B2-1139

1. CHECK VOLTAGE BETWEEN ECU AND BODY.

- 1) Turn ignition switch to "ON".
- 2) Measure voltage between ECU connector terminal and body.

Connector & Terminal/Specified voltage:

(B127) No. 11 — Body/Approx. 12 V (Economy switch OFF)
0 V (Economy switch ON)

2. CHECK ECONOMY SWITCH.

- 1) Disconnect connector from economy switch.
- 2) Measure resistance between economy switch terminals.

Connector & Terminal / Specified resistance:

No.2 — No.4 / 1M Ω min.(Economy switch OFF)
0 Ω (Economy switch ON)

3. CHECK HARNESS CONNECTOR BETWEEN ECU AND ECONOMY SWITCH.

- 1) Disconnect connectors from ECU and economy switch.
- 2) Measure resistance between ECU connector and economy switch connector.

Connector & Terminal/Specified resistance:

(B127) No. 11 — (R73) No. 2/0 Ω

- 3) Measure resistance between economy switch connector and body.

Connector & Terminal/Specified resistance:

(R73) No. 2 — Body/1 M Ω min.
(R73) No. 4 — Body/0 Ω

• SELECT MONITOR FUNCTION MODE

Mode: FA2

LED No.: 4

Condition: Ignition switch ON

ON/OFF Signal:

LED OFF (Economy switch OFF)

LED ON (Economy switch ON)

Q: TROUBLE CODE (51) — NEUTRAL SWITCH (MT) —

CONTENT OF DIAGNOSIS:
Abnormal signal entered from neutral switch

TROUBLE SYMPTOM:
Erroneous idling

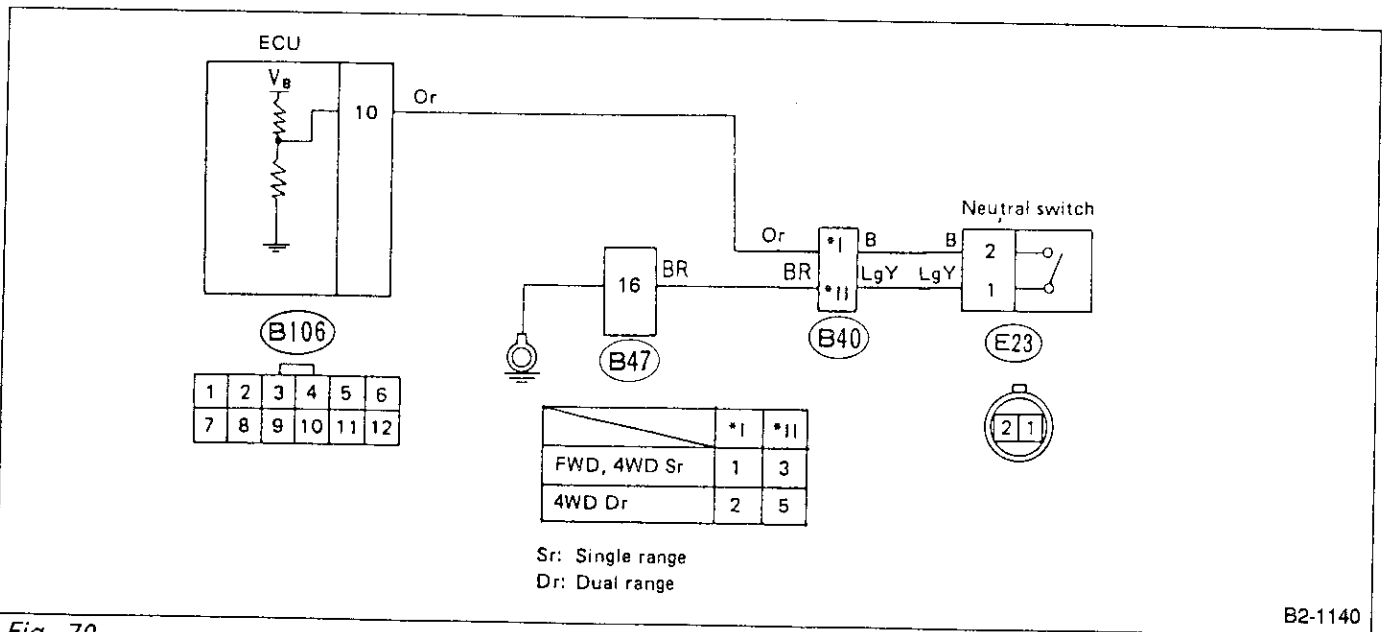
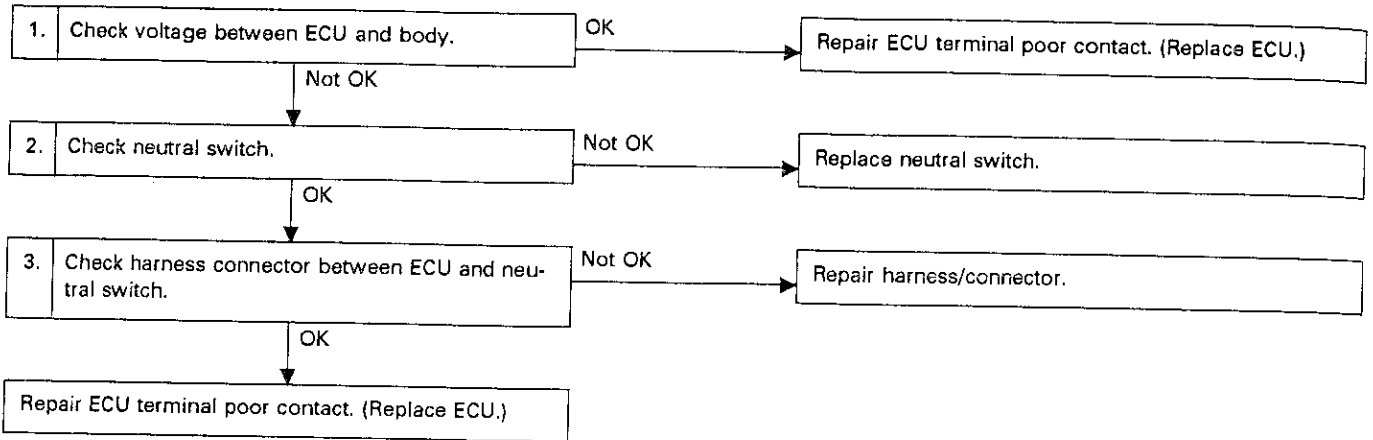


Fig. 70

B2-1140

1. CHECK VOLTAGE BETWEEN ECU AND BODY.

- 1) Turn ignition switch to "ON".
- 2) Measure voltage between ECU connector terminal and body.

Connector & Terminal/Specified voltage:
 (B106) No. 10 — Body/Approx. 7 V, min. (Neutral position)
 0 V (Other than neutral position)

2. CHECK NEUTRAL SWITCH.

- 1) Disconnect neutral switch connectors.
- 2) Measure resistance between neutral switch terminals while shifting shift lever from Neutral to any other position.

Connector & Terminal/Specified resistance:
 (E23) No. 1 — No. 2/ 1 MΩ min.(Neutral position)
 0 Ω (Other than neutral position)

3. CHECK HARNESS CONNECTOR BETWEEN ECU AND NEUTRAL SWITCH.

- 1) Disconnect connectors from ECU and neutral switch.
- 2) Measure resistance between ECU connector and neutral switch connector.

Connector & Terminal/Specified resistance:
 (B106) No. 10 — (E23) No. 2/0 Ω

- 3) Measure resistance between neutral switch connector and body.

Connector & Terminal/Specified resistance:
 (E23) No. 2 — Body/1 MΩ min.
 (E23) No. 1 — Body/0 Ω

• SELECT MONITOR FUNCTION MODE

Mode: FA0
LED No.: 7
Condition: Ignition switch ON
ON/OFF Signal:
 LED OFF (Other than neutral position)
 LED ON (Neutral position)

R: TROUBLE CODE (51) — INHIBITOR (AT) —

CONTENT OF DIAGNOSIS:
Abnormal signal entered from inhibitor switch

TROUBLE SYMPTOM:
Erroneous idling

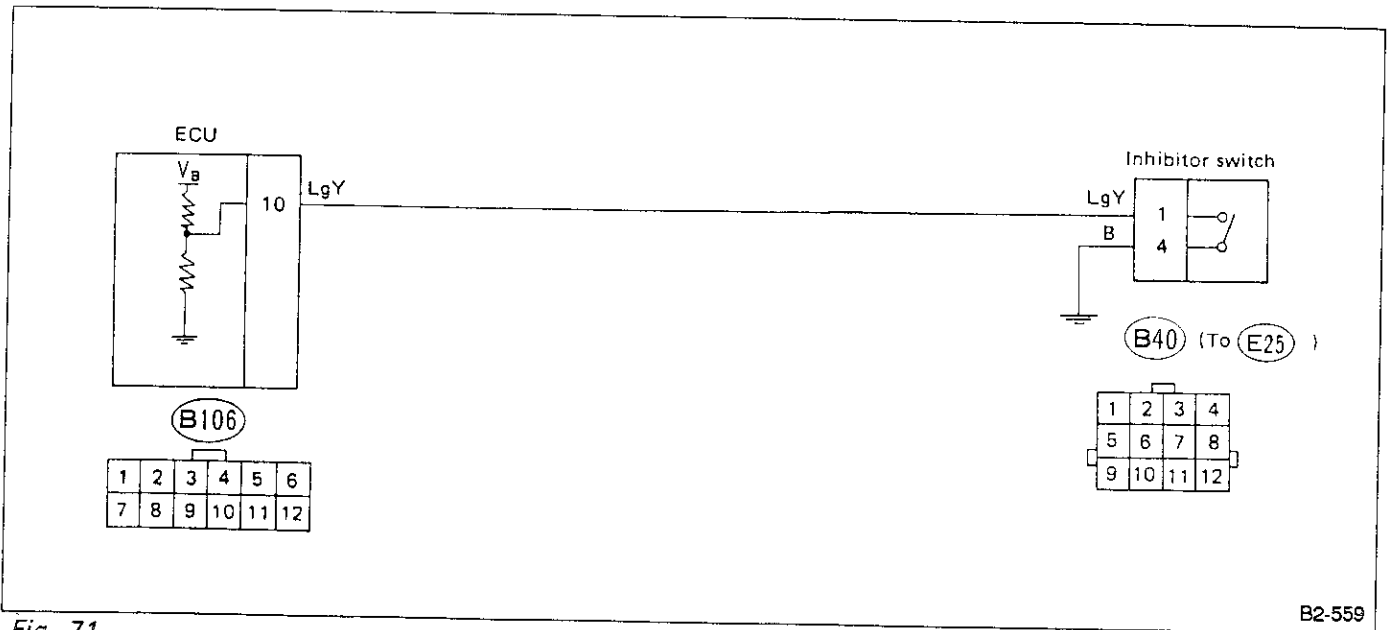
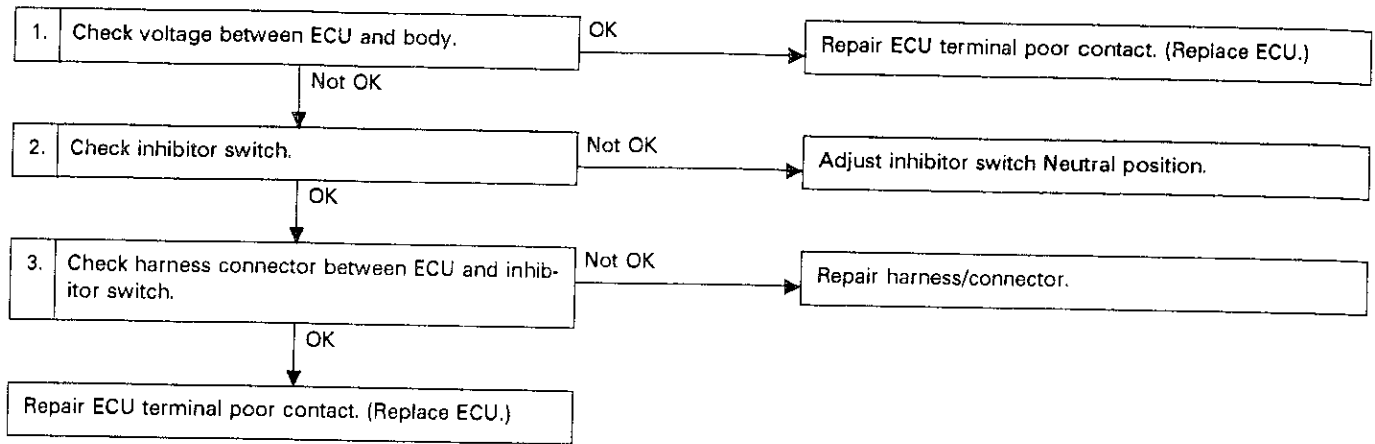


Fig. 71

B2-559

1. CHECK VOLTAGE BETWEEN ECU AND BODY.

- 1) Turn ignition switch to "ON".
- 2) Measure voltage between ECU connector terminal and body.

Connector & Terminal/Specified voltage:
 (B106) No. 10 — Body/0 V (N Range)
 10 — 13 V (Other than N Range)

2. CHECK INHIBITOR SWITCH.

- 1) Disconnect transmission connectors.
- 2) Measure resistance between inhibitor switch terminals while shifting select lever from Neutral to any other position.

Connector & Terminal / Specified resistance:
 (E25) No. 1 — No. 4 / 1 MΩ min. (Neutral position)
 0 Ω (Other than neutral position)

3. CHECK HARNESS CONNECTOR BETWEEN ECU AND INHIBITOR SWITCH.

- 1) Disconnect connectors from ECU and inhibitor switch.
- 2) Measure resistance between ECU connector and inhibitor switch connector.

Connector & Terminal/Specified resistance:
 (B106) No. 10 — (B40) No. 1/0 Ω

- 3) Measure resistance between inhibitor switch connector and body.

Connector & Terminal/Specified resistance:
 (B40) No. 1 — Body/1 MΩ min.
 (B40) No. 4 — Body/0 Ω

● SELECT MONITOR FUNCTION MODE

Mode: FA0
 LED No.: 7
 Condition: Ignition switch ON
 ON/OFF Signal:
 LED OFF (Other than neutral position)
 LED ON (N Range)

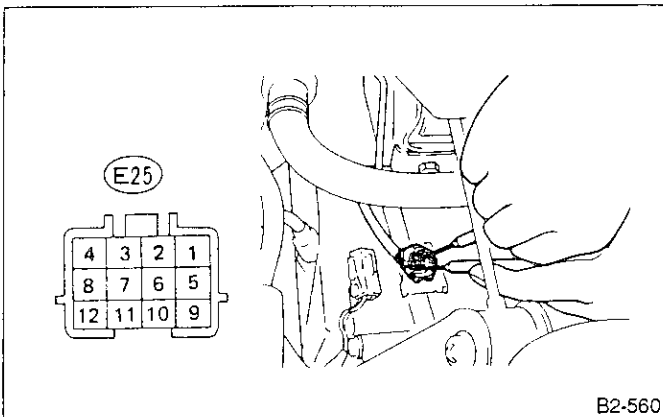
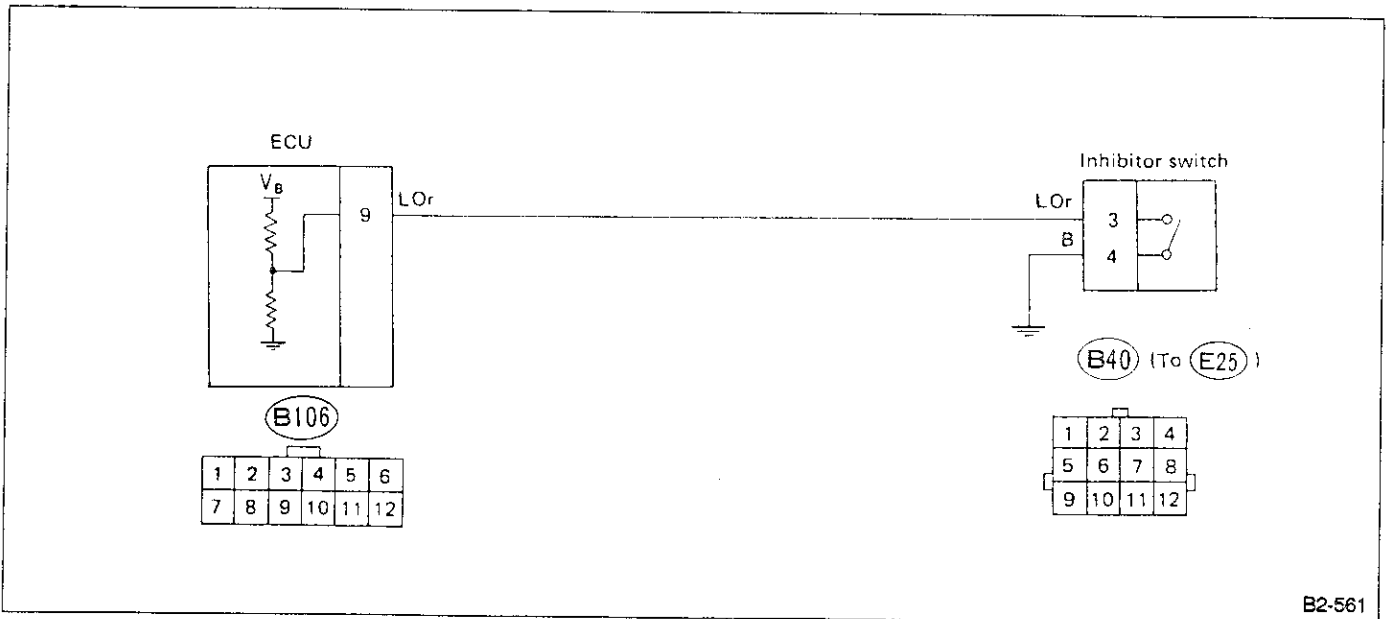
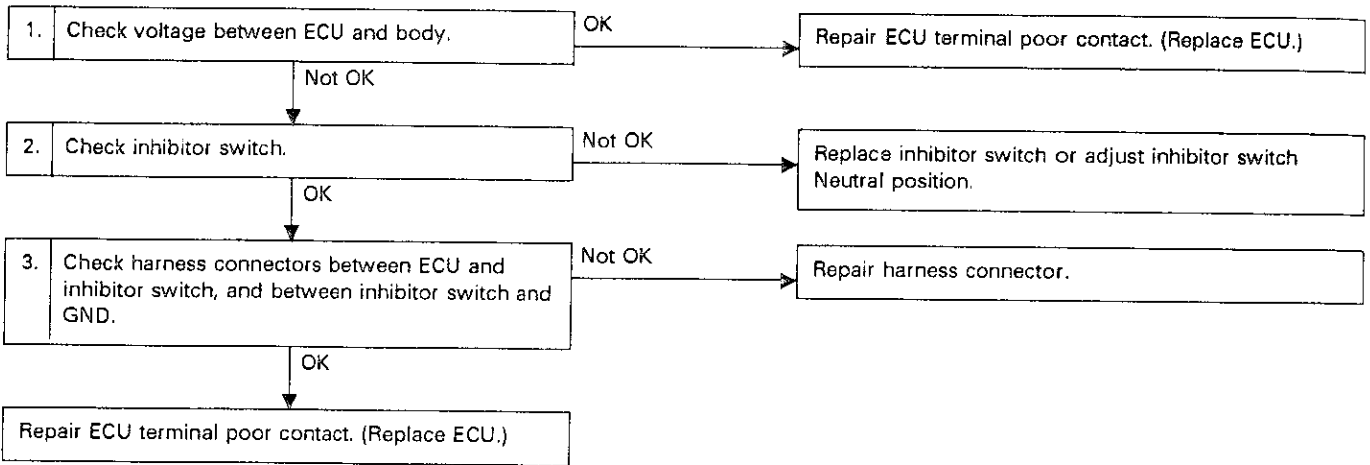


Fig. 72

S: TROUBLE CODE (52) — PARKING SWITCH (AT) —

CONTENT OF DIAGNOSIS:
Abnormal signal entered from parking switch

TROUBLE SYMPTOM:
● Erroneous idling
● Poor warm-up performance with select lever in "P"



B2-561

Fig. 73

1. CHECK VOLTAGE BETWEEN ECU AND BODY.

- 1) Turn ignition switch to "ON".
- 2) Measure voltage between ECU connector terminal and body.

Connector & Terminal/Specified voltage:
 (B106) No. 9 — Body/0 V (P Range)
 10 — 13 V, (Other than P Range)

Connector & Terminal/Specified resistance:
 (B40) No. 3 — Body/1 MΩ min.
 (B40) No. 4 — Body/0 Ω

• **SELECT MONITOR FUNCTION MODE**

Mode: FA0
LED No.: 8
Condition: Ignition switch ON
ON/OFF Signal: LED OFF (Other than P Range)
 LED ON (P Range)

2. CHECK INHIBITOR SWITCH.

- 1) Disconnect connector from inhibitor switch.
- 2) Measure resistance between inhibitor switch terminals while shifting select lever from Neutral to any other position.

Connector & Terminal/Specified resistance:
 (E25) No. 3 — No. 4/ 0 Ω (P Range)
 1 MΩ min. (Other than P Range)

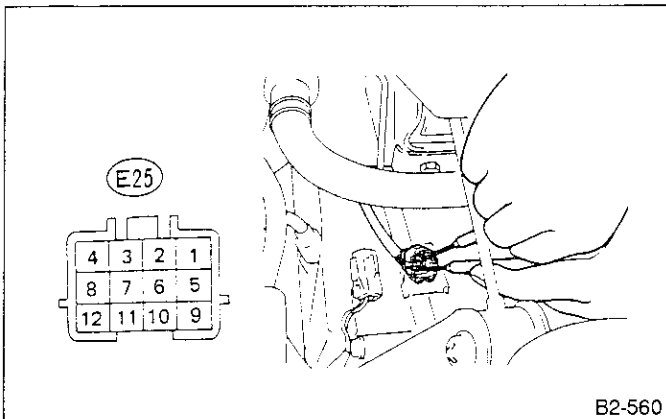


Fig. 74

3. CHECK HARNESS CONNECTOR BETWEEN ECU AND INHIBITOR SWITCH.

- 1) Disconnect connectors from ECU and inhibitor switch.
- 2) Measure resistance between ECU connector and inhibitor switch connector.

Connector & Terminal/Specified resistance:
 (B106) No. 9 — (B40) No. 3/0 Ω

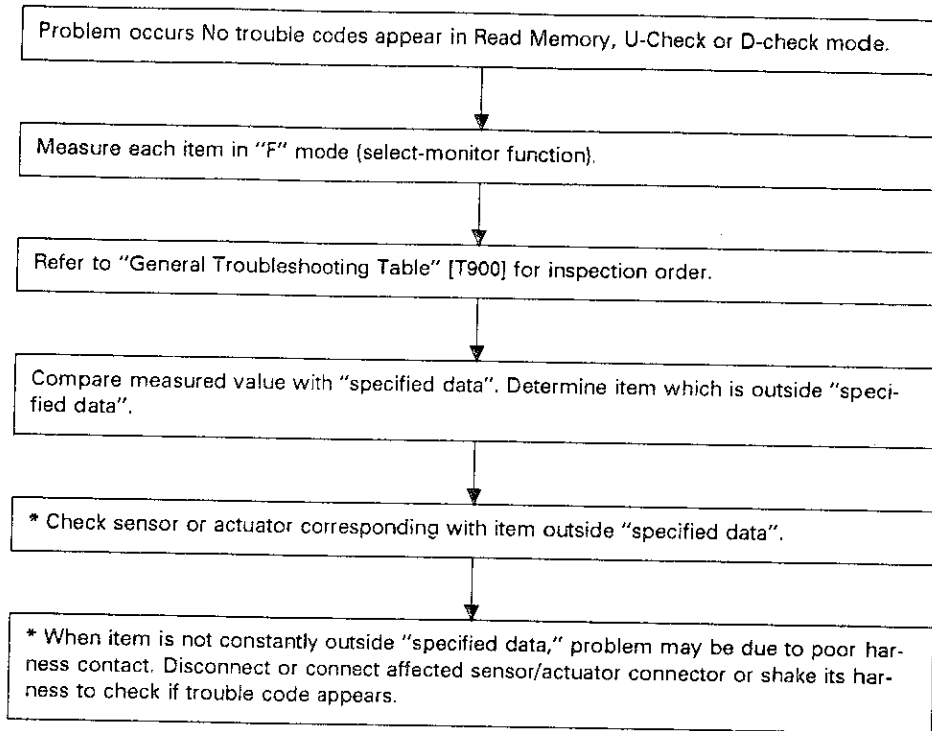
- 3) Measure resistance between inhibitor switch connector and body.

8. Troubleshooting Chart with Select Monitor

A: BASIC TROUBLESHOOTING CHART

If no trouble codes appear in the Read Memory, U-Check or D-check mode (although problems have occurred or are occurring), measure performance characteristics of sensors, actuators, etc., in the "F" mode (select-monitor function), and compare with the "basic data" to determine the cause of problems.

Applicable cartridge of select monitor: No. 498348800



B: MODE F01 — Battery voltage (VB) —

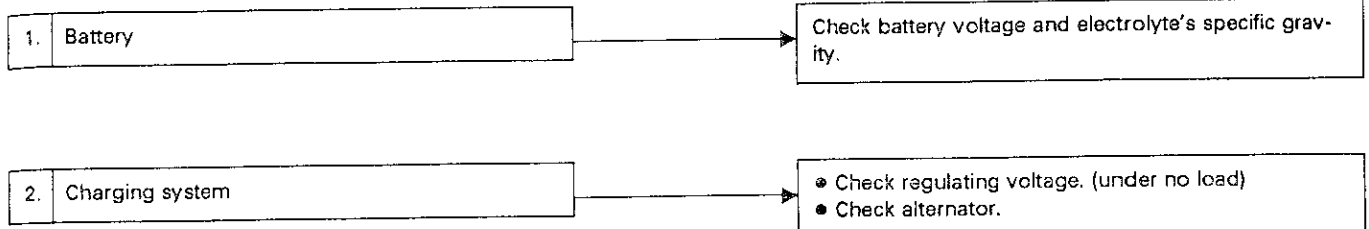
CONDITIONS:

- (1) Ignition switch "ON"
- (2) Idling after warm-up

SPECIFIED DATA:

- 10 — 12 V (Ignition switch ON, engine OFF)
- 12 — 14 V (Engine at idle)

● Probable cause (item outside "specified data")



C: MODE F03 — Vehicle speed signal (VSP) —

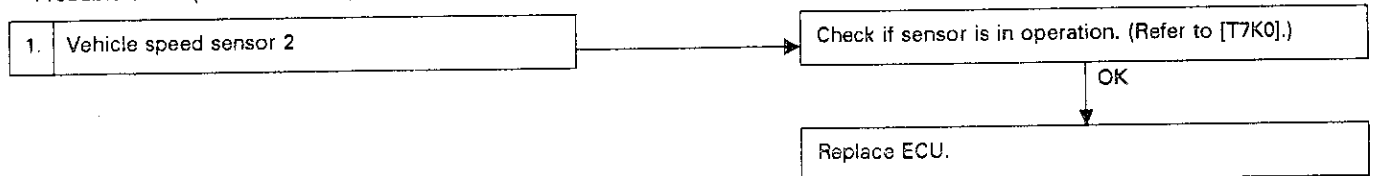
CONDITION:

Raise vehicle until all wheels are off ground, and support with safety stands. Operate vehicle at constant speed.

SPECIFICATION DATA:

Compare speedometer with monitor indications. Probable cause (if indications are different)

● Probable cause (item outside "specified data")



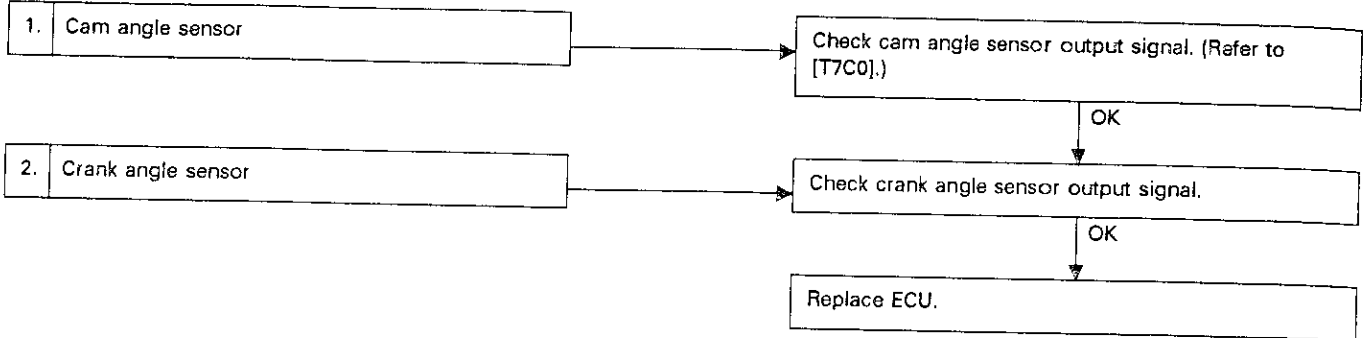
F02 = Vehicle speed signal: Vehicle speed is indicated in mile per hour (MPH).

D: MODE F04 — Engine speed (EREV) —

CONDITION:
Operate engine at constant speed.

SPECIFIED DATA:
Compare engine speeds indicated on engine tester monitor.

• Probable cause (if outside specified data)



E: MODE F06 — Water temperature sensor signal (TW) —

CONDITION:
Idling after warm-up

SPECIFIED DATA:
80 — 95 deg C

• Probable cause (if outside specified data)



F05 = Water temperature signal (TW): To be indicated in "deg F".

F: MODE F07 — Ignition timing —

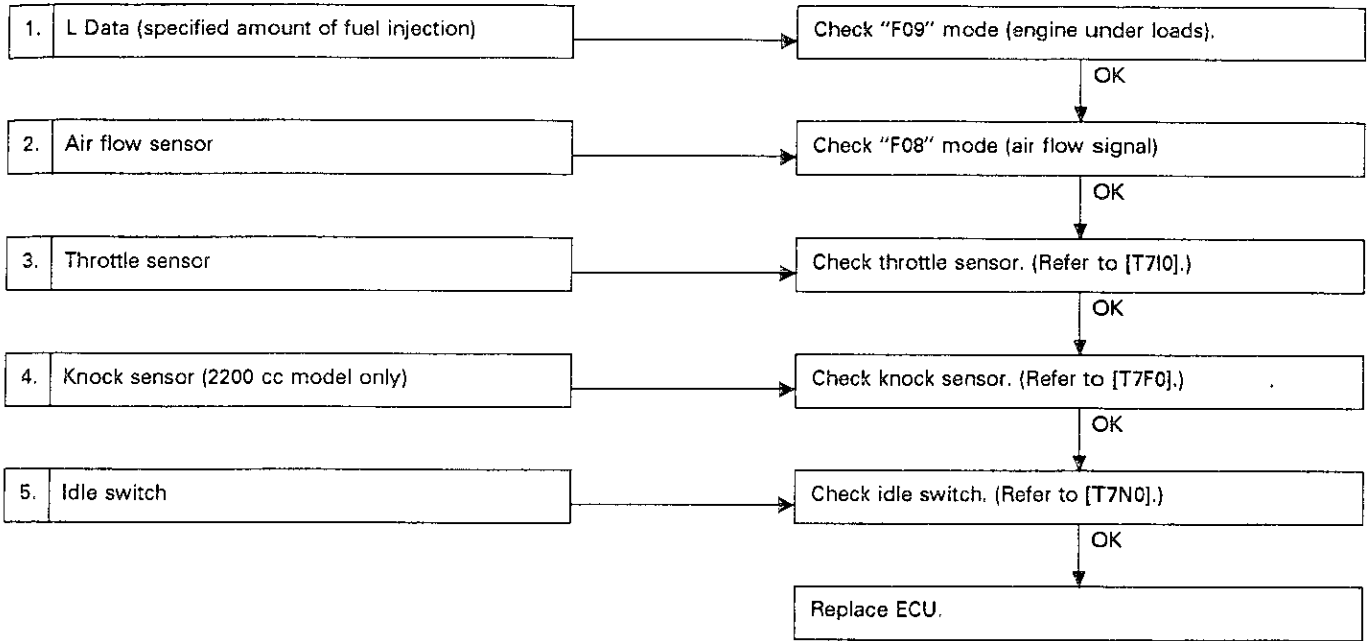
CONDITIONS:

- (1) While idling after warm-up
- (2) Gear in neutral position

SPECIFIED DATA:

12 — 28 deg

● Probable cause (if items outside specified data)

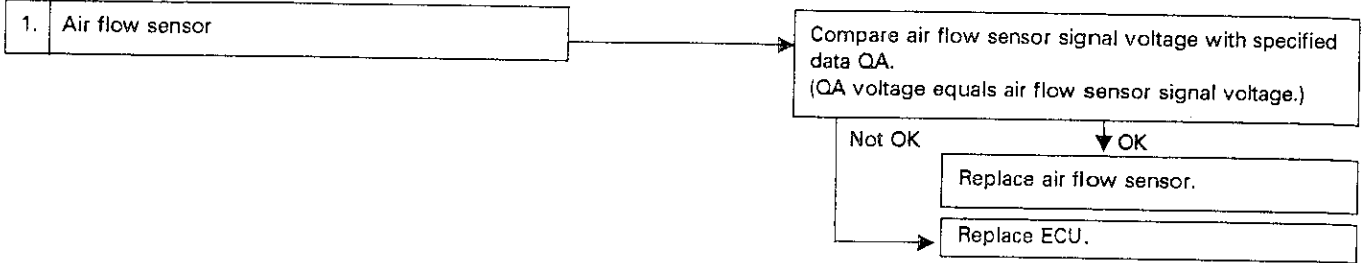


G: MODE F08 — Air flow signal (QA) —

CONDITION:
Idling after warm-up

SPECIFIED DATA:
0.8 — 1.2 V

• Probable cause (if outside specified data)

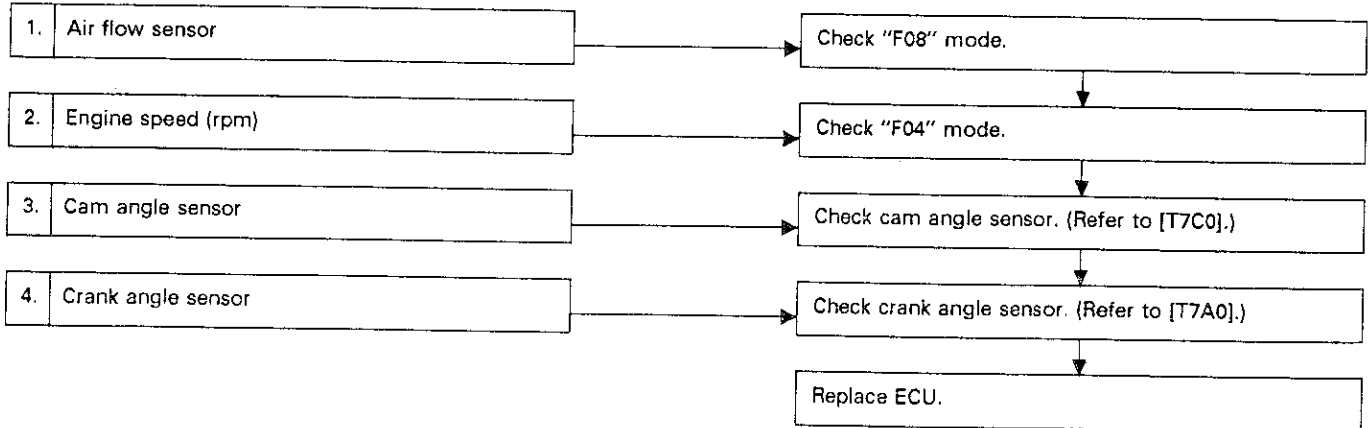


H: MODE F09 — Engine under loads (L DATA) —

CONDITION:
Idling after warm-up

SPECIFIED DATA:
15 — 20

• Probable cause (if outside specified data)



I: MODE F10 — Throttle sensor signal —

CONDITION:
Check while changing from "fully-closed" to "fully-open" throttle valve.

SPECIFIED DATA:
4.7 V → 0.9 V *Engine throttle change must be smooth.

• Probable cause (if outside specified data)

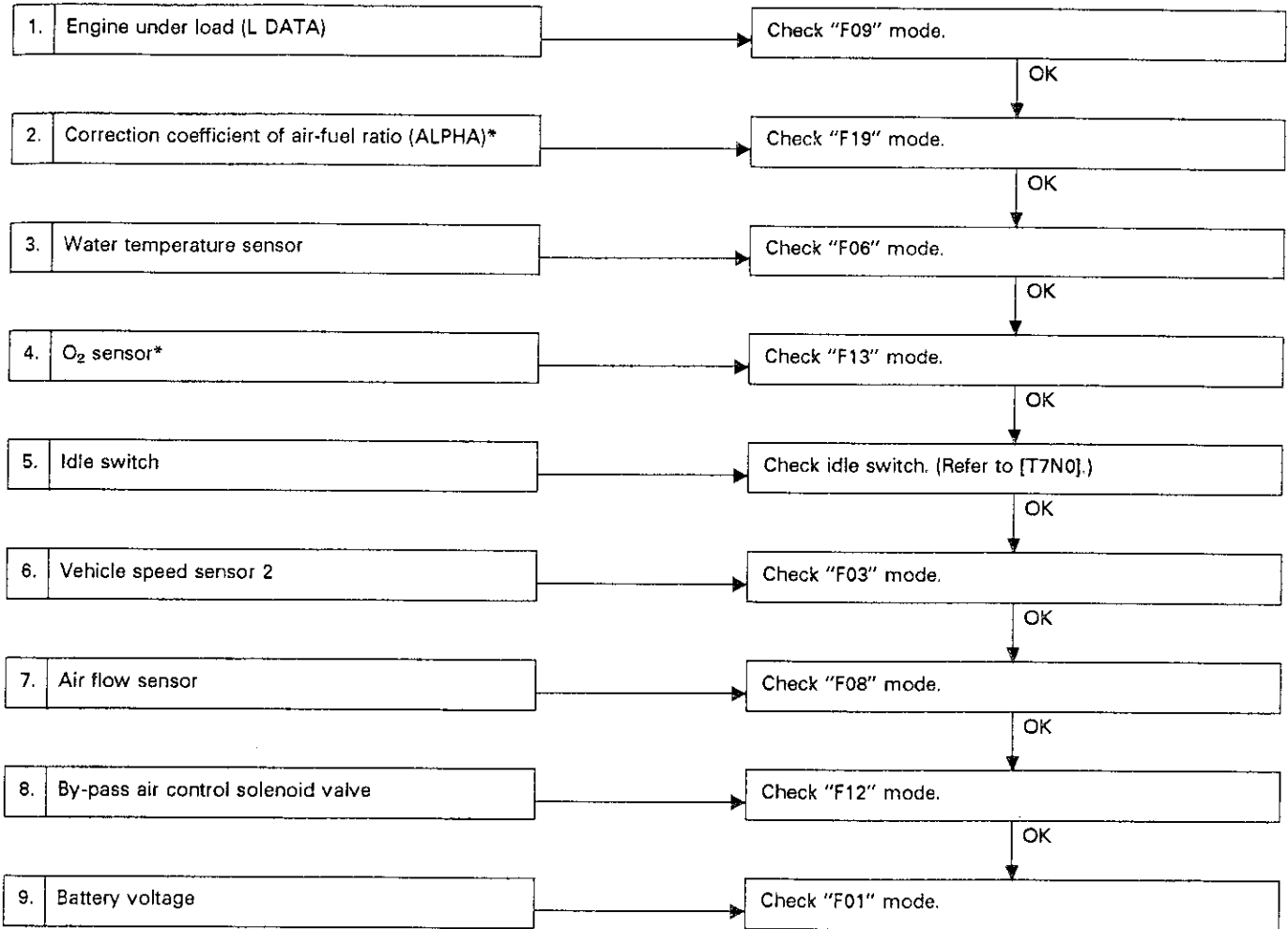


J: MODE F11 — Fuel injection duration (TIM) —

CONDITION:
Idling after warm-up

SPECIFIED DATA:
3.0 — 3.7 ms

• Probable cause (if outside specified data)



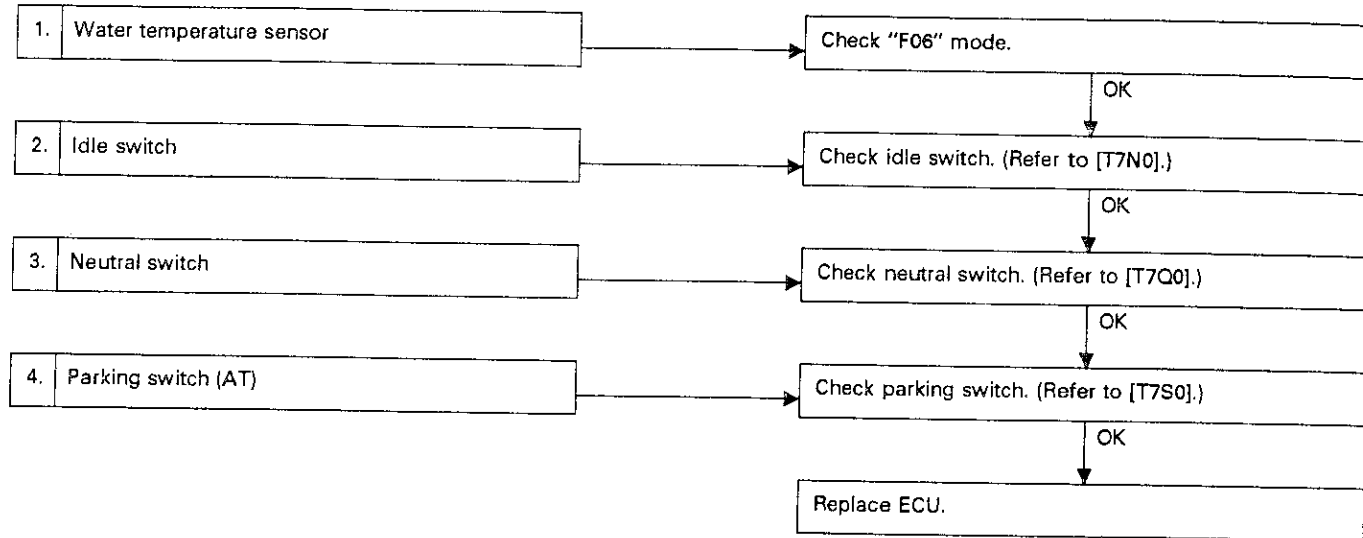
* Catalyst model only

K: MODE F12 — By-pass air control solenoid valve (ISC) —

CONDITIONS:
 (1) Idling after warm-up
 (2) Air conditioner "OFF"
 (3) Radiator fan "OFF"
 (4) Battery voltage: Greater than 13 volts
 (5) Sea level (Not high altitudes)

SPECIFIED DATA:
 30 — 40%

• Probable cause (if outside specified data)

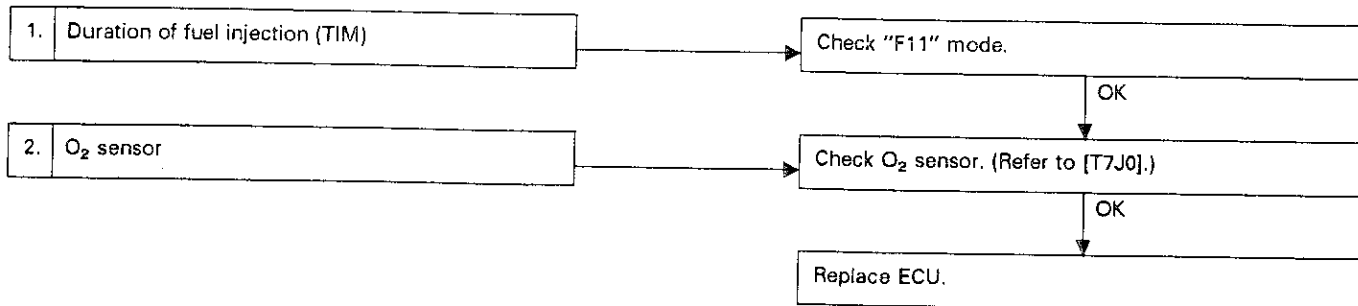


L: MODE F13 — O₂ sensor (O₂) [Catalyst model only] —

CONDITION:
 Idling after warm-up

SPECIFIED DATA:
 0.1 — 0.9 V

• Probable cause (if outside specified data)

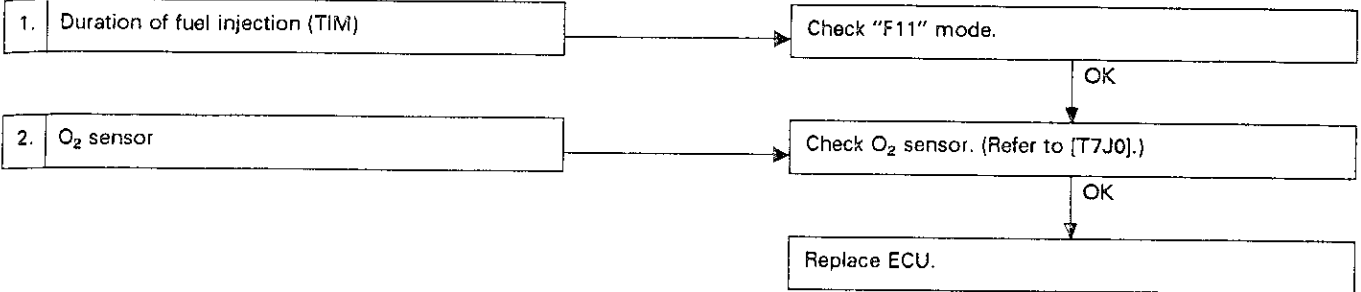


M: MODE F15 — Maximum O₂ sensor signal voltage (O₂ Max.) [Catalyst model only] —

CONDITION:
Idling after warm-up

SPECIFIED DATA:
0.7 — 1.0 V

• Probable cause (if outside specified data)

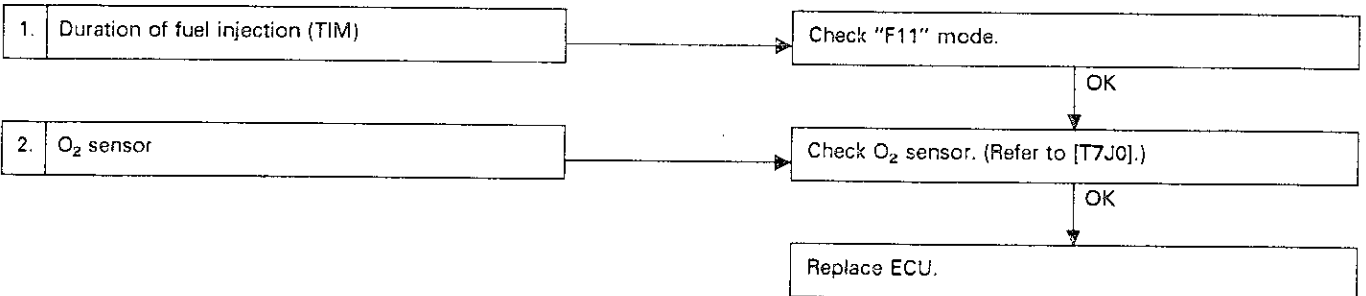


N: MODE F16 — Minimum O₂ sensor signal voltage (O₂ Min.) [Catalyst model only] —

CONDITION:
Idling after warm-up

SPECIFIED DATA:
0 — 0.2 V

• Probable cause (if outside data)

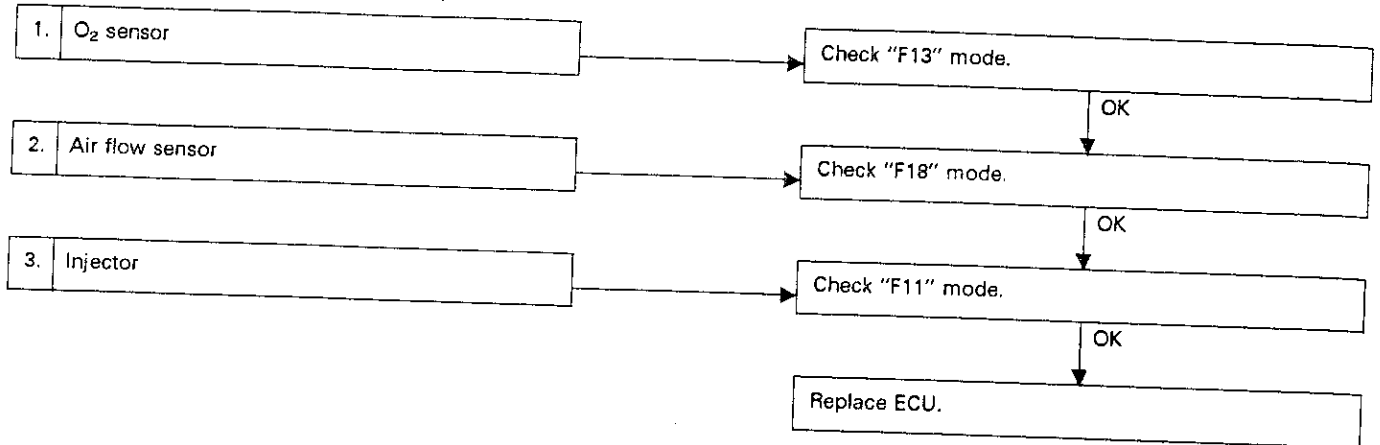


O: MODE F16 — Correction coefficient of air-fuel ratio (ALPHA) [Catalyst model only] —

CONDITION:
Idling after warm-up

SPECIFIED DATA:
— 3.2 to + 3.2

• Probable cause (if outside specified data)

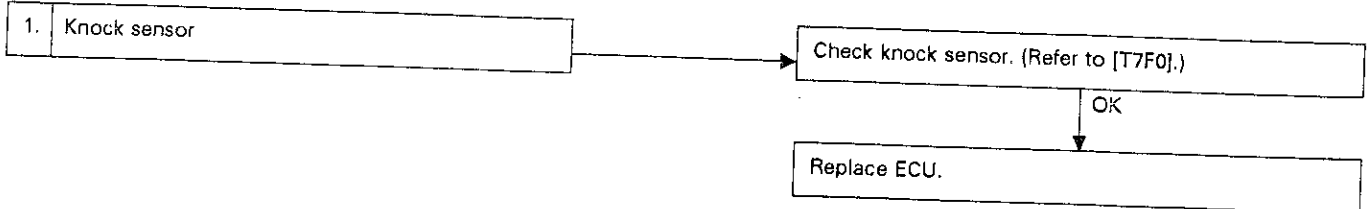


P: MODE F17 — Correction value of ignition timing (RTRD) [2200 cc model only] —

CONDITION:
—

SPECIFIED DATA:
— 10 to + 10 deg

• Probable cause (if outside specified data)



9. General Troubleshooting Table

Priority of "parts to check" is shown by figures (1, 2, 3, 16).

Parts to check			ECU power supply	Air sensor	Water temperature sensor	Idle switch	Throttle sensor	Fuel pump	Pressure regulator	Fuel injector	Igniter (power transistor)	Ignition coil	Spark plug	* Knock sensor	Cam angle sensor	Crank angle sensor	Air control valve	**O ² sensor	
Symptom	Failure of engine to start	Initial combustion does not occur.	1	10	11			5	6	7	2	3	4		8	9			
		Initial combustion occurs.	1		10			2	3	4	5	6	7		8	9	11		
		Engine stalls after initial combustion.	1	2	7		8	4	5	6	11	12	13		9	10	3		
	Rough idling		1	3	12	8	7	4	5	6	9	10	11		13	14	2	15	
	Hard to drive at constant speed		1	4	6	8	7	3	2	9	12	13	14		10	11		5	
	Poor acceleration/deceleration		1	2	6	7	8	3	4	5	13	14	15	9	11	12	10		
	Poor return to idle				3	2												1	
	Backfire				3	4	5		6	7					2	1			
	Knocking			1	2				4	6					3		7		
	Excessive fuel consumption			3	4				1	2									
Shocks while driving		1	8						7	4	5	6		2	3				
Poor engine revving			2	3	4	5		1											
Remarks		Include engine grounding circuit.															Check hoses		

*: 2200 cc model only
 **: Catalyst model only

SUBARU.

1992

**SERVICE
MANUAL**

	Page
M MECHANISM AND FUNCTION	2
1. General	2
2. Throttle Body	4
3. Fuel Line	7
4. Sensor and Switch	9
5. Control System	13
6. Self-diagnosis System	24
T TROUBLESHOOTING	27
1. Precautions	27
2. Pre-inspection	27
3. Troubleshooting Chart for Self-diagnosis System	28
4. Output Modes of Select Monitor	33
5. Control Unit I/O Signal	35
6. Troubleshooting for Engine Starting Failure	37
7. Troubleshooting Chart with Trouble Code	46
8. Troubleshooting Chart with Select Monitor	76
9. General Troubleshooting Table	85



M MECHANISM AND FUNCTION

1. General

For conventional carburetors, the SPFI system substitutes a throttle body containing one fuel injector. It electronically controls the amount of fuel injection from the fuel injector and supplies the optimum mixture to suit all operating conditions of the engine.

The features of this SPFI system are as follows:

1) An ECU, which has a compact and high-performance 8-bit microcomputer in it, is a total fuel injection system. It processes signals sent from various sensors and accurately controls the amount of fuel injected to meet varying engine operating conditions.

(1) Fuel injection control

The ECU's microcomputer processes data sent from various sensors to inject fuel into the injection body twice during every engine rotation (or once every 180° rotation of the crankshaft).

(2) Air-fuel ratio learning control

A learning control system with a high level of accuracy learns and compensates for "out-of-fuel injection" resulting from changes in engine operation with the elapse of time. Learning control is achieved by receiving a signal sent from the O₂ sensor.

(3) Ignition timing control

The ECU's microcomputer processes signals sent from the crank angle sensor, cam angle sensor and air flow sensors to provide the optimum ignition timing under varying engine load and speed.

(4) Ignition timing learning control

The ECU's microcomputer learns and compensates for "out-of-ignition timing" resulting from the octane rating of fuel and changes in engine operation with the elapse of time. A high level of ignition timing control is accomplished based on a signal sent from the knock sensor.

(5) Idle speed control

The by-pass air control solenoid valve is controlled by signals sent from the water temperature sensor and air conditioning switch to provide automatic control of the target idle rpm.

2) A back-up function is provided in case of SPFI system failure.

(1) A self-diagnostic function for quick location of faulty systems or parts.

(2) A fail-safe function is also provided.

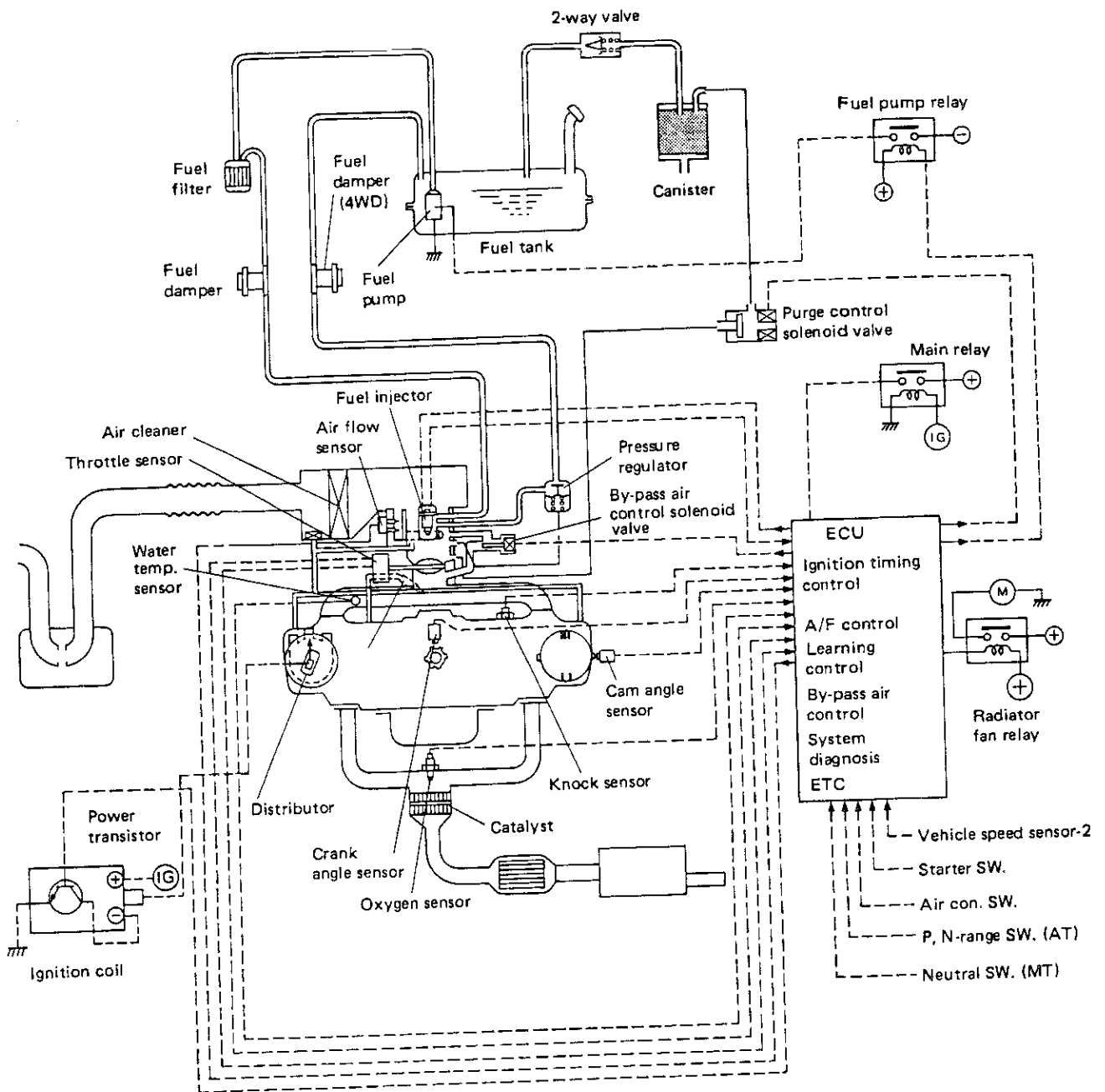


Fig. 1

2. Throttle Body

1. GENERAL

The throttle body is located in the center of the intake manifold and is regulated by an electronic control to supply the proper fuel (mixture) to the cylinders.

It consists of an air flow sensor, injector, by-pass air control valve, pressure regulator, throttle valve, throttle sensor and a throttle valve opening mechanism (throttle opener). All these parts are associated with the throttle body.

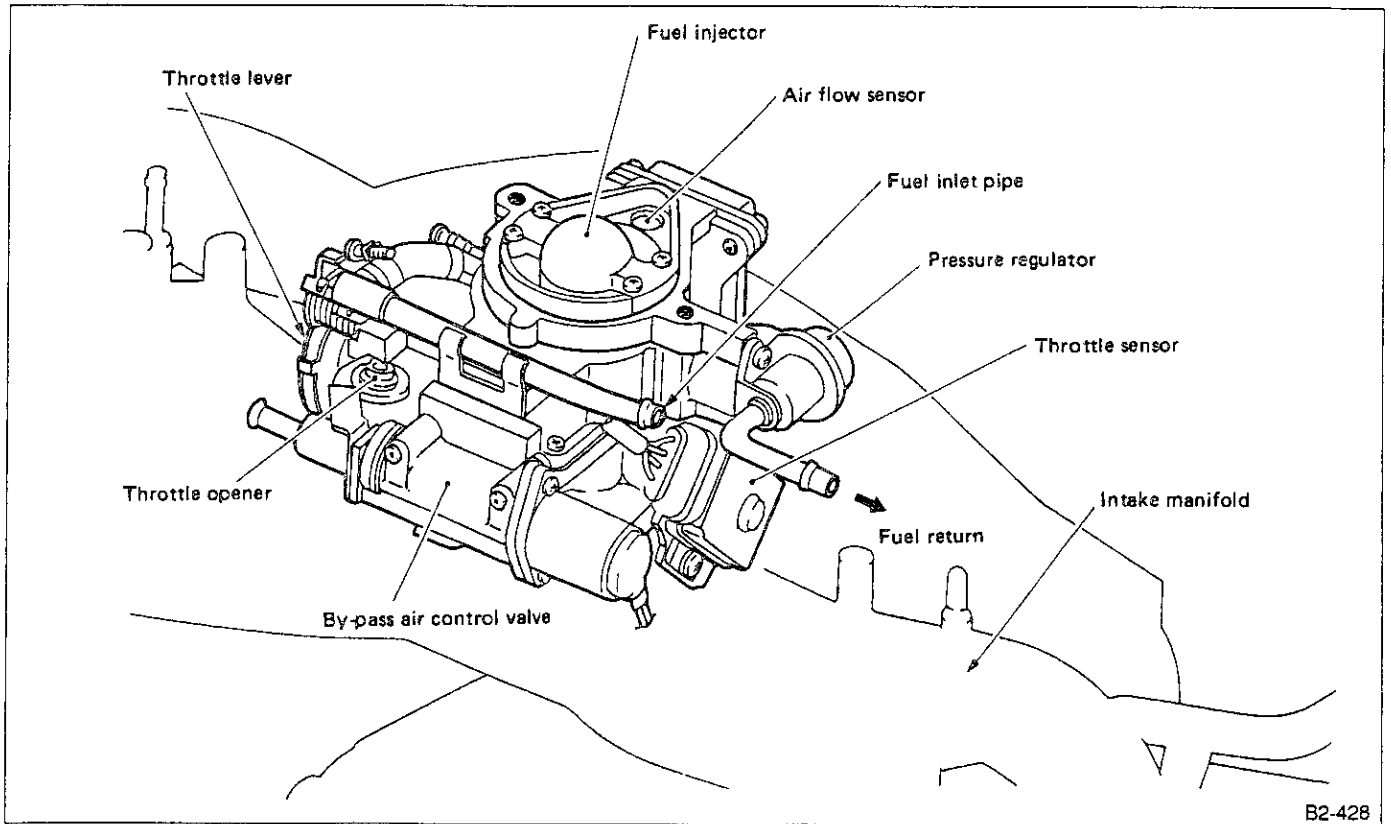
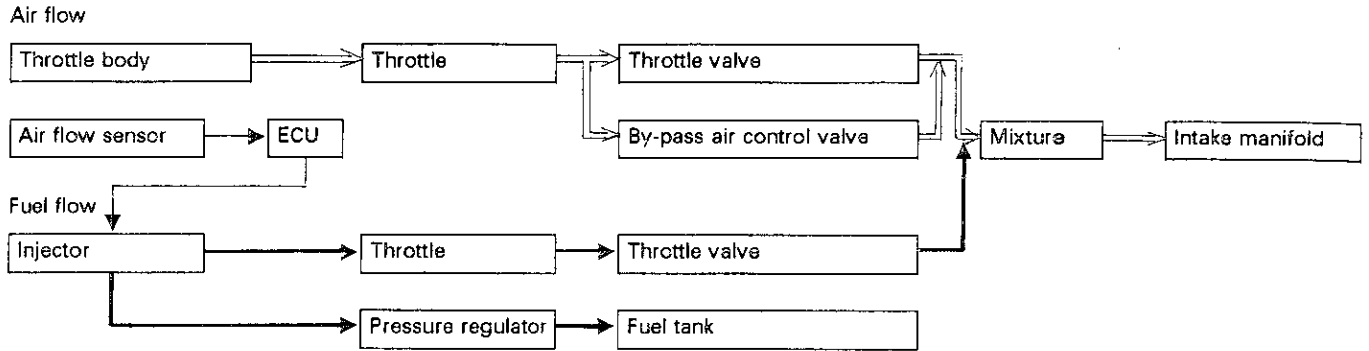


Fig. 2

B2-428

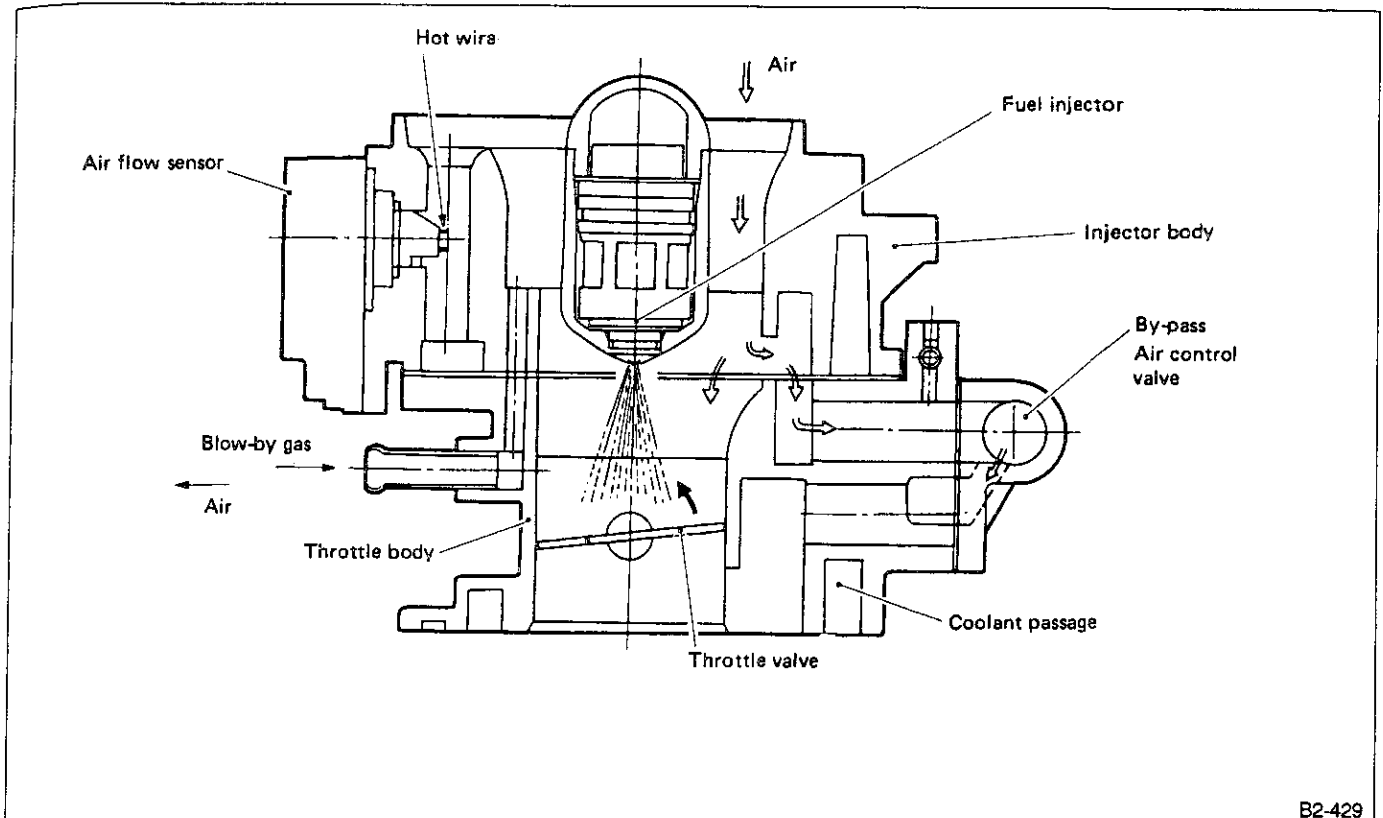


Fig. 3

2. AIR FLOW SENSOR

The air flow sensor is a hot wire type which features a high level of metering accuracy. It is integrated with the upstream portion of the injection body. The hot wire used as a heating conductor is made from platinum and located in the air-flow section. When the hot wire is heated by a constant current flow through it, the rise in the hot wire temperature is reduced as the amount of air flow increases. This is because air deprives the hot wire of any heat. For this reason, the hot wire temperature can be constantly maintained by increasing the current flow through the hot wire with increases in the amount of air flow. Since the resistance value of the hot wire varies with the air flowrate, a circuit which produces voltage in relation to the air flowrate is used to measure the voltage value to monitor the mass flowrate of air.

(Features)

- (1) The air density is automatically compensated for as the circuit meters the mass flowrate of air.
- (2) Excellent responsiveness
- (3) No mechanical parts are used to increase performance reliability.
- (4) Compact size
- (5) The air flow sensor is located in the by-pass line to keep the platinum conductor clean at all times.

3. THROTTLE SENSOR

A throttle position sensor is provided with a potentiometer and idle switch interlocked with the throttle valve shaft is utilized.

This throttle position sensor sends the SPFI control unit a potentiometer output signal corresponding to the opening of the throttle valve and an idle switch signal that turns ON only when the throttle is opened nearly to the idle position.

Using these signals, the SPFI control unit precisely controls the air-fuel ratio during acceleration and deceleration as well as idling.

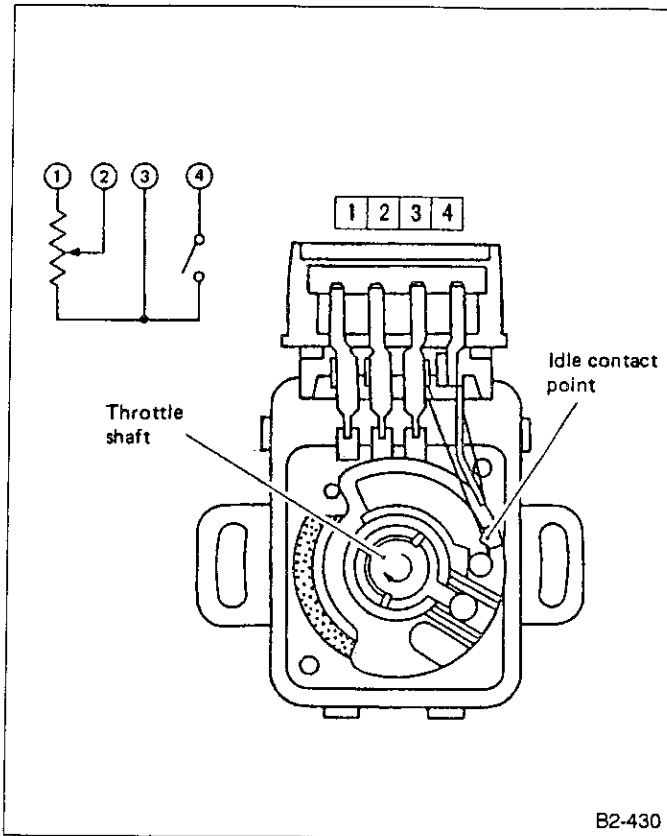


Fig. 4

4. BY-PASS AIR CONTROL SOLENOID VALVE

The by-pass air control solenoid valve is unified with the injection body and regulates the amount of intake air which bypasses the throttle valve built into the injection body. It is activated by a signal sent from the ECU to mainly maintain engine idle speed to the target rpm. The by-pass air control solenoid valve is a "current-proportion" solenoid type which consists of a coil, valve shaft, spring and housing. The housing is unified with the injection body and is provided with the air passage which is opened or closed by the valve.

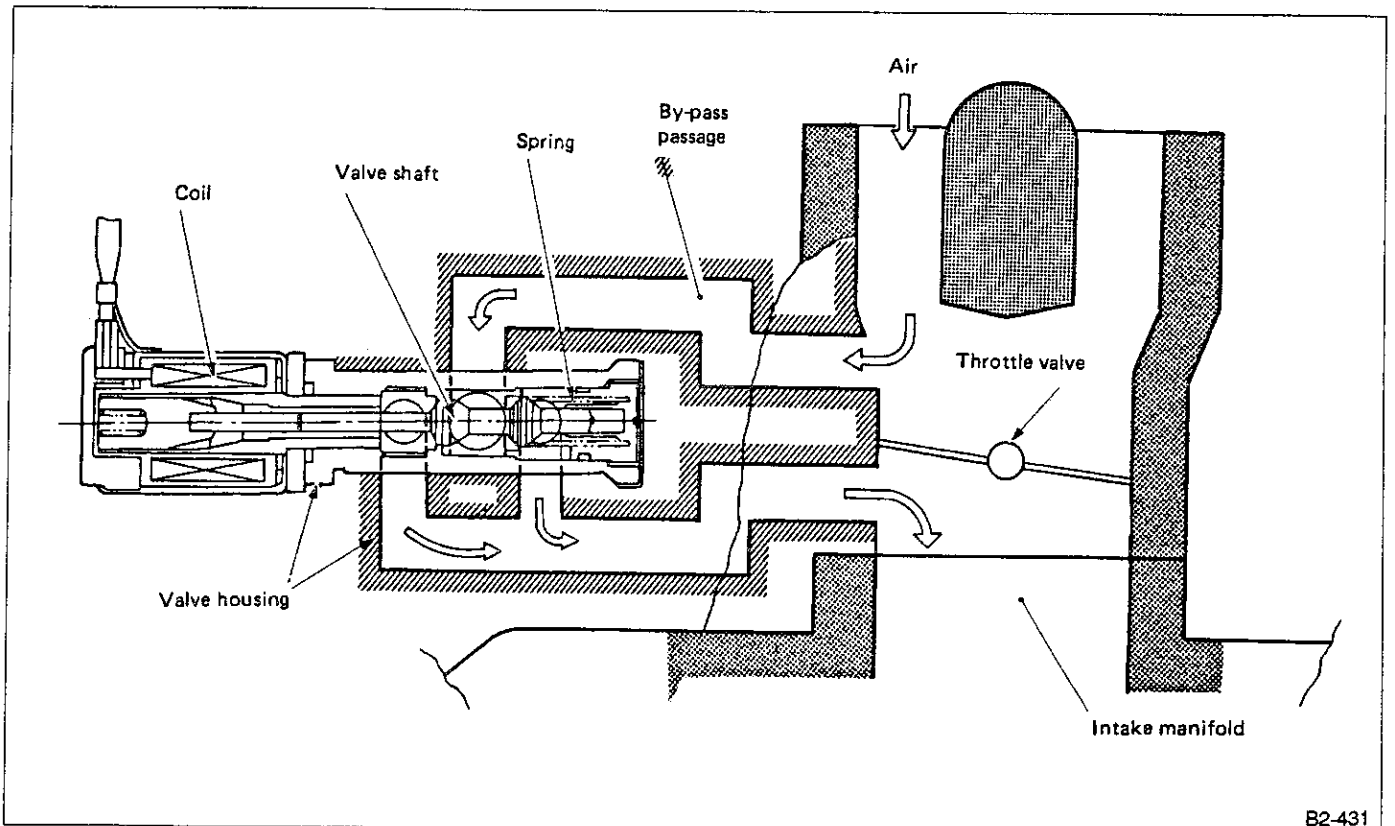


Fig. 5

5. FUEL INJECTOR

The fuel injector is built into the upstream of the throttle valve of the throttle body. It is a solenoid valve type which injects fuel into the throttle body in response to an injection signal computed by the ECU. The fuel injection system utilizes an SPI method by which the amount of fuel required for all cylinders is injected twice per engine rotation (or once for each 180° rotation).

1) Construction

The fuel injector has a nozzle at the end, and the end of the needle is provided with a spring-loaded ball valve. The ball valve is held closed by a return spring via the needle and plunger.

The fuel inlet is provided with a filter which prevents entry of foreign matter into the fuel injector.

2) Operation

When the solenoid coil is energized, the plunger is pulled to fully open the needle ball valve (which is integrated with the plunger) so that fuel is injected through the nozzle. Since the movement of the ball valve, the diameter of the nozzle and fuel pressure are constant, the amount of fuel injected is controlled only for the duration that the solenoid coil is energized by a signal sent from the ECU.

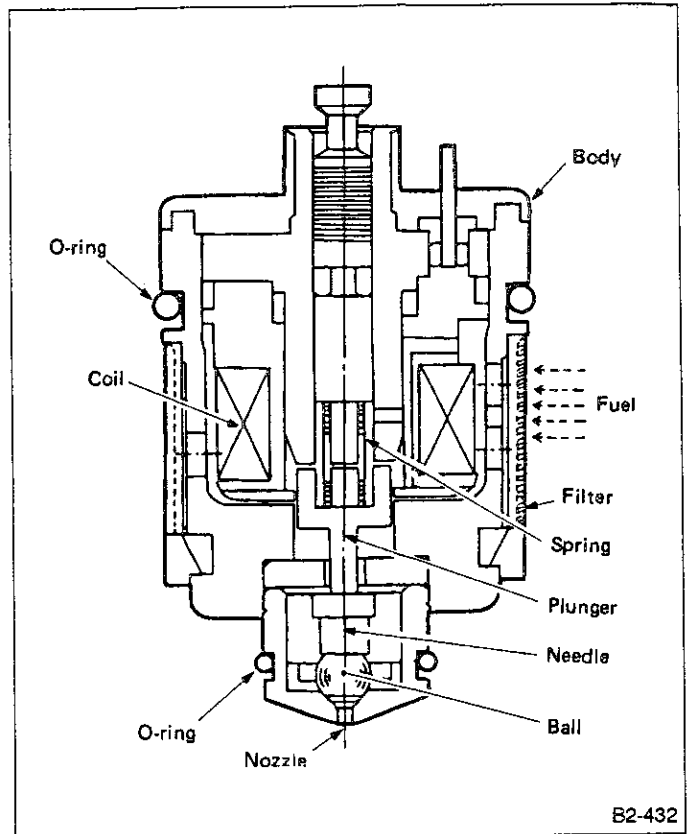
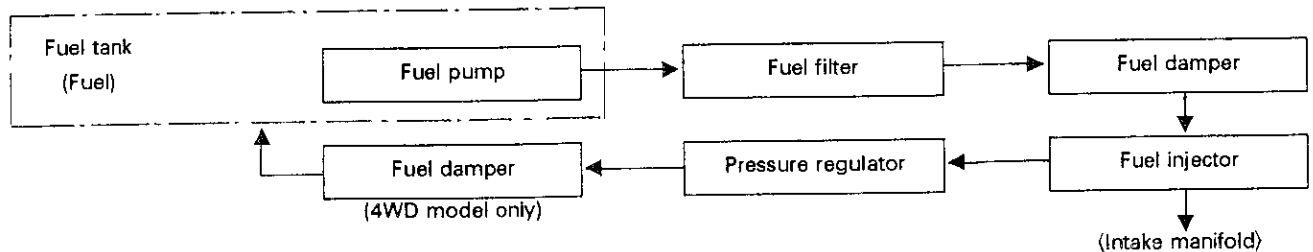


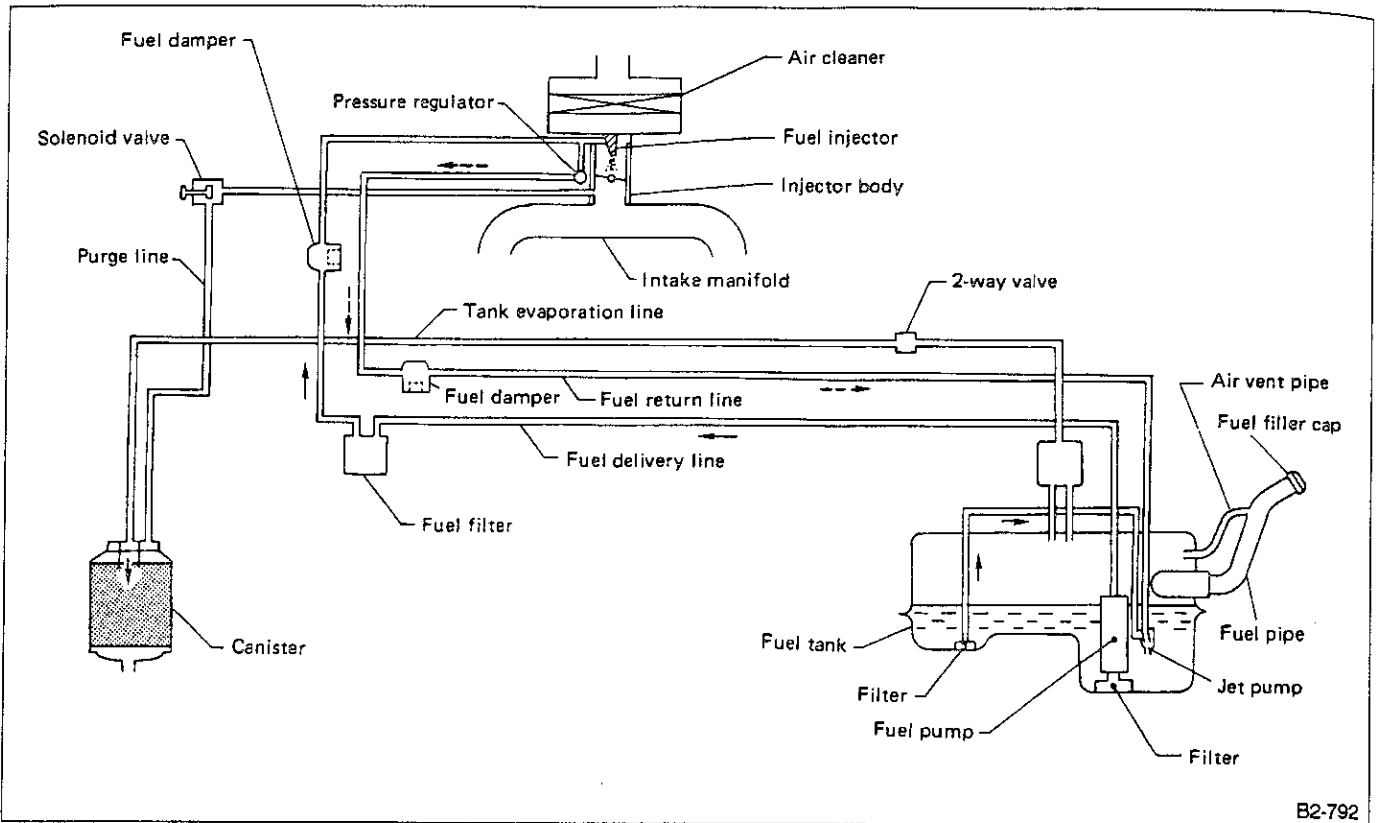
Fig. 6

3. Fuel Line

1. GENERAL

Fuel pressurized by the fuel pump built into the fuel tank is delivered to fuel injectors by way of the fuel pipe, fuel filter and fuel damper. Fuel is regulated to the optimum pressure level by the pressure regulator on the way to the injectors.





B2-792

Fig. 7

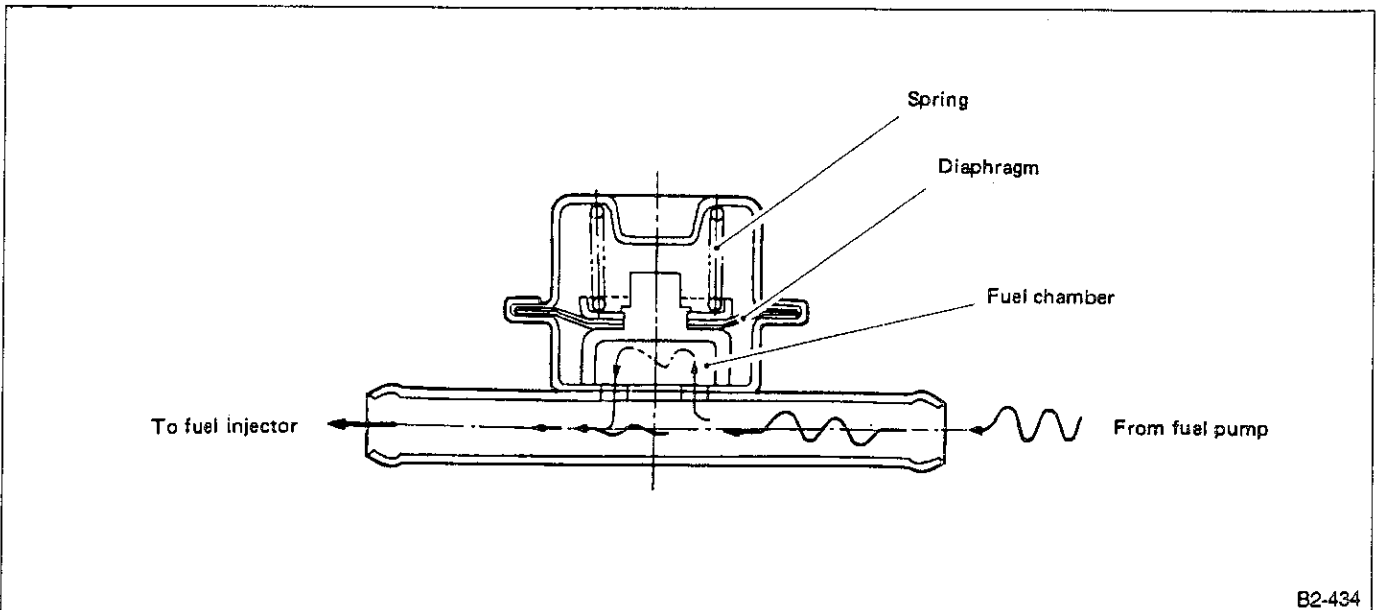
2. FUEL DAMPER

The fuel damper is located between the fuel filter and injection body. Since fuel delivered from the fuel pump under high pressure is intermittently injected by the fuel injector, "pulsations" will occur in the fuel line. The fuel damper effectively absorbs such pulsations, dampening variations in fuel pressure and reducing noise result-

ing from injector operation.

Fuel pulsation acts to displace the diaphragm in the fuel chamber, which in turn is absorbed by a spring. In this way, pulsating pressure is rectified so that stabilized fuel pressure is applied to the fuel injector.

On 4WD model, the fuel damper is located on fuel return line.



B2-434

Fig. 8

3. PRESSURE REGULATOR

The pressure regulator is located on the left side of the injector body and integrated with the body. It is regulated to maintain a constant level of pressure differential between fuel delivered under pressure from the fuel pump and the air pressure in the air passage at the injector. This occurs so that the amount of fuel injected to the fuel injector is constantly maintained only during the opening of the fuel injector. Excess fuel returns to the fuel tank.

1) Construction

The pressure regulator has a fuel chamber and spring chamber which is partitioned by a diaphragm. A valve and valve seat are provided in the fuel chamber while the spring chamber has an air passage which is linked with the throttle body.

2) Operation

When fuel pressure is greater than 250.1kPa (2.55 kg/cm², 36.3psi) (in relation to air passage pressure), the diaphragm moves to the right so that the valve is unseated. Fuel will then return to the fuel tank. When fuel pressure is less than 250.1kPa (2.55 kg/cm², 36.3 psi) the diaphragm moves to the left by spring force so that the valve is seated. This will shut off the fuel return passage, which in turn increases fuel pressure. The above operation is repeated to maintain fuel pressure at 250.1kPa (2.55 kg/cm², 36.3psi).

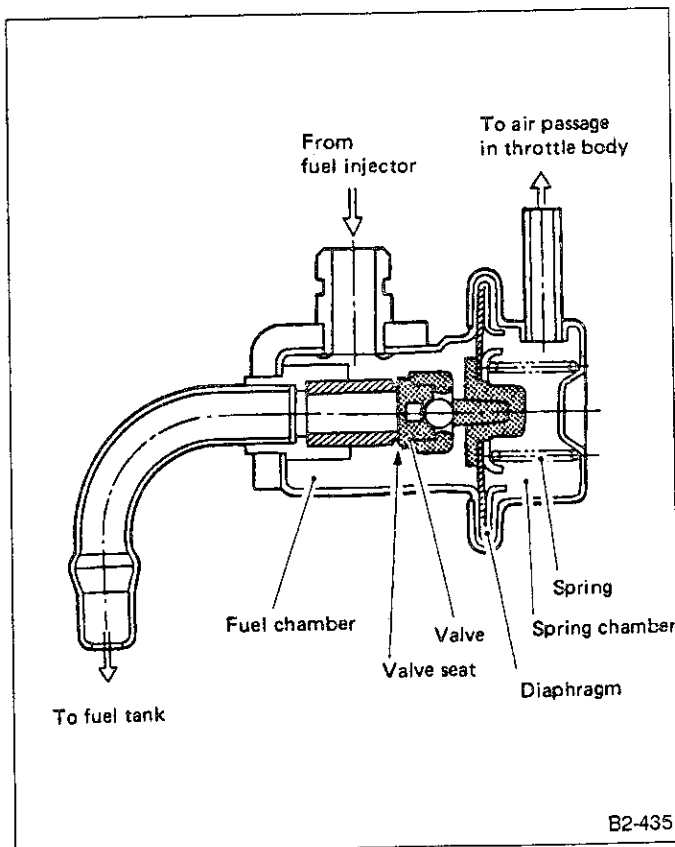


Fig. 9

4. Sensor and Switch

1. O₂ SENSOR

The O₂ sensor is used to sense oxygen concentration in the exhaust gas. If the fuel ratio is leaner than the stoichiometric ratio in the mixture (i.e. excessive amount of air), the exhaust gas contains more oxygen. To the contrary, if the fuel ratio is richer than the stoichiometric ratio, the exhaust gas contains hardly any oxygen. Therefore, examination of the oxygen concentration in exhaust gas makes it possible to show whether the air/fuel ratio is leaner or richer than the stoichiometric ratio. The O₂ sensor has a zirconia tube (ceramic) which generates voltage if there is a difference in oxygen concentration between the inside and outside of the tube. Platinum is coated on the inside and outside of the zirconia tube for the purpose of catalysis and electrode provision. The hexagon screw on the outside is grounded to the exhaust pipe, and the inside is connected to the ECU through the harness.

A ceramic heater is employed to improve performance at low temperature.

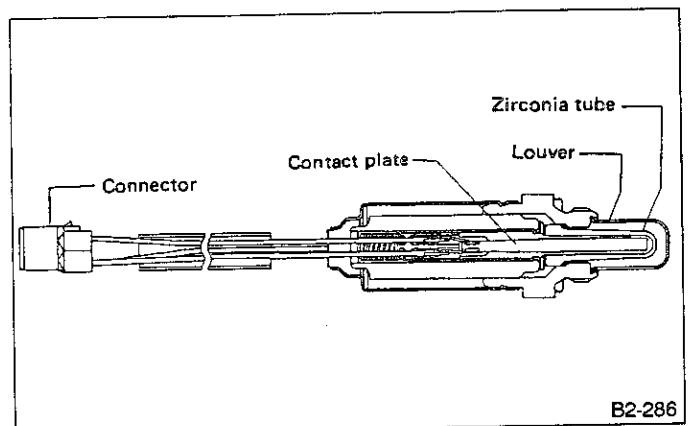


Fig. 10

When rich air-fuel mixture is burnt in the cylinder, the oxygen in the exhaust gases reacts almost completely through the catalytic action of the platinum coating on the surface of the zirconia tube. This results in a very large difference in the oxygen concentration between the inside and outside, and the electromotive force generated is large.

When a lean air-fuel mixture is burnt in the cylinder, oxygen remains in the exhaust gases even after the catalytic action, and this results in a small difference in the oxygen concentration. The electromotive force is very small.

The difference in oxygen concentration changes greatly in the vicinity of the optimum air-fuel ratio, and hence the change in the electromotive force is also large. By inputting this information into the ECU, the air-fuel ratio of the supplied mixture can be determined easily. The O₂ sensor does not generate much electromotive force when the temperature is low. The characteristics of the

electromotive force stabilize at temperature of approximately 300 to 400°C (572 to 752°F).

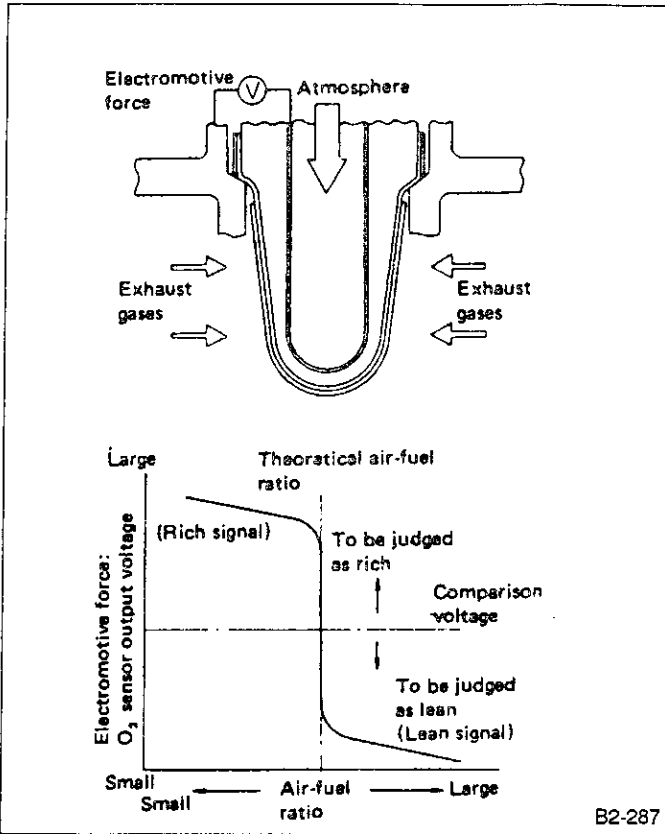


Fig. 11

2. WATER TEMPERATURE SENSOR

The water temperature sensor is located on the water pipe which is made of aluminum alloy. Its thermistor changes resistance with respect to temperature. A water temperature signal converted into resistance is transmitted to the ECU to control the amount of fuel injection, ignition timing, purge control solenoid valve, etc.

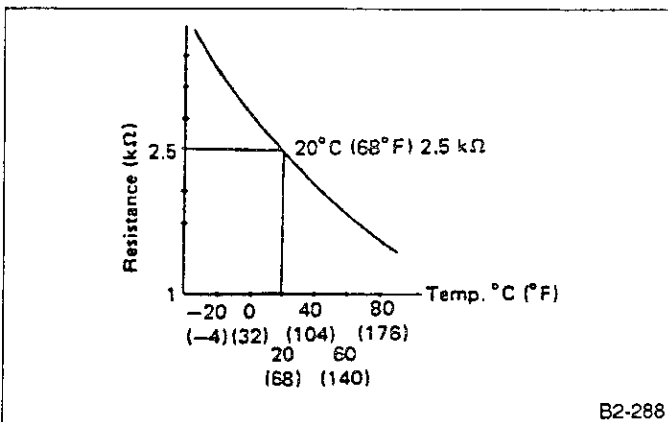


Fig. 12

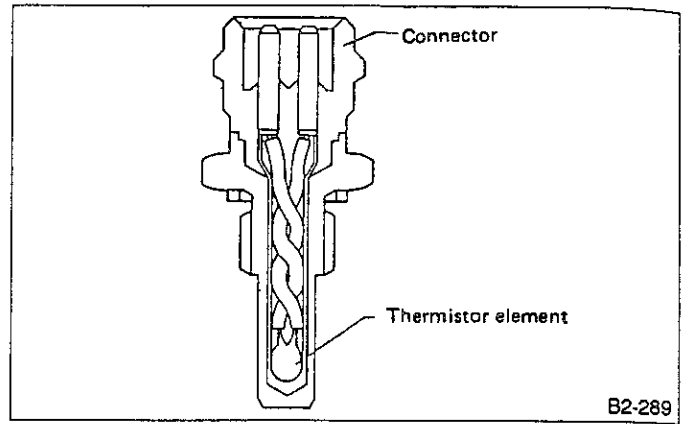


Fig. 13

3. KNOCK SENSOR

The knock sensor is installed on the cylinder block, and senses knocking signals from each cylinder. This knock sensor is a piezo-electric type which converts knocking vibrations into electric signals. It consists of a piezo-electric element, weight, and case. If knocking occurs in the engine, the weight in the case moves causing the piezo-electric element to generate a voltage.

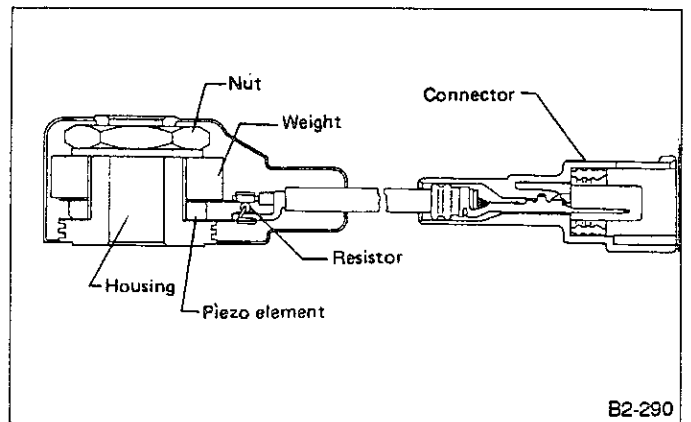


Fig. 14

4. CRANK ANGLE SENSOR

The crank angle sensor is installed on the oil pump, located in the front center portion of the cylinder block, to detect the crank angle position. It is designed so that the ECU accurately reads the number of pulses which occur when protrusions provided at the perimeter of the crank sprocket (rotating together with the crankshaft) cross the crank angle sensor. The crank angle sensor is a molded type which consists of a magnet, cores, coil, terminals, etc.

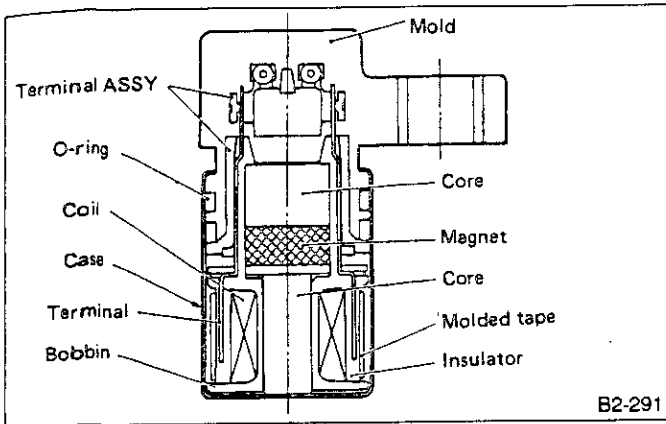


Fig. 15

Function

The crank sprocket is provided with six protrusions. Crank rotation causes these protrusions to cross the crank angle sensor so that magnetic fluxes in the coil change with the change in air gap between the sensor pickup and the sprocket. The change in air gap induces an electromotive force which is transmitted to the ECU.

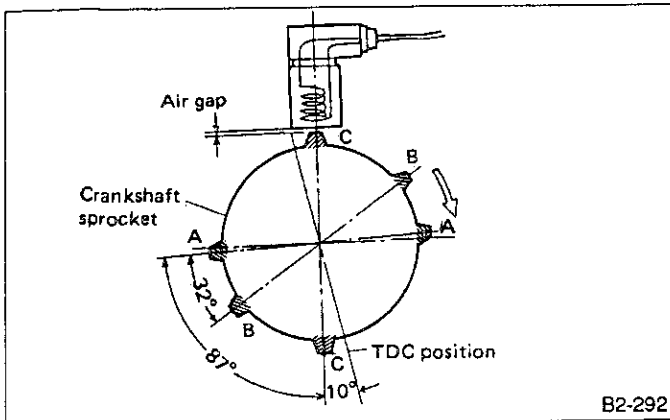


Fig. 16

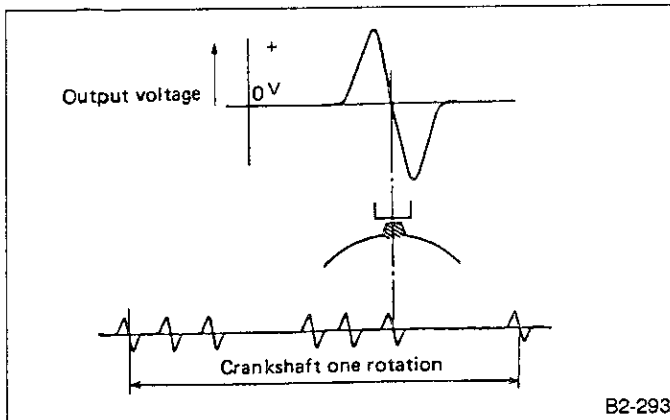


Fig. 17

5. CAM ANGLE SENSOR

The cam angle sensor is located on the left-hand camshaft support to detect the combustion cylinder at any one moment.

It is designed so that the ECU accurately reads the number of pulses which occur when protrusions provided on the back of the LH camshaft-drive sprocket cross the sensor.

Internal construction and the basic operating principle of the cam angle sensor are similar to those of the crank angle sensor. A total of seven protrusions (one each at two locations, two at one location and three at one location) are arranged in four equal parts of the sprocket, as shown below.

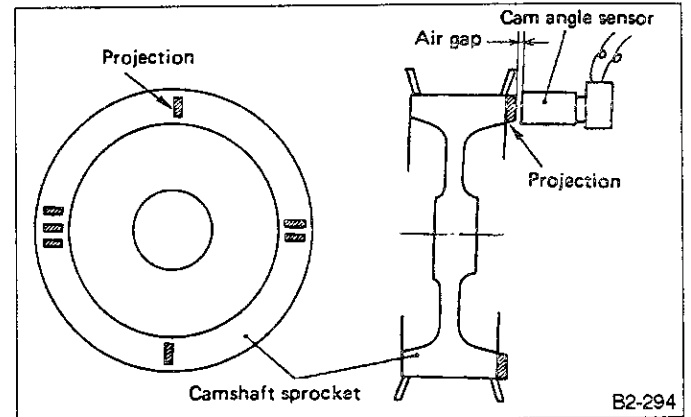


Fig. 18

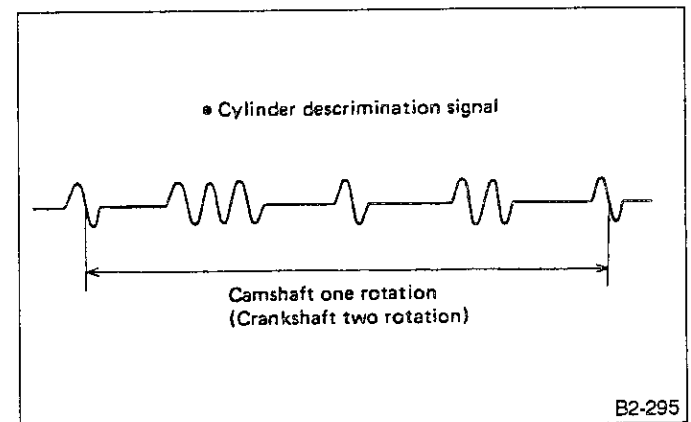


Fig. 19

6. VEHICLE SPEED SENSOR 2

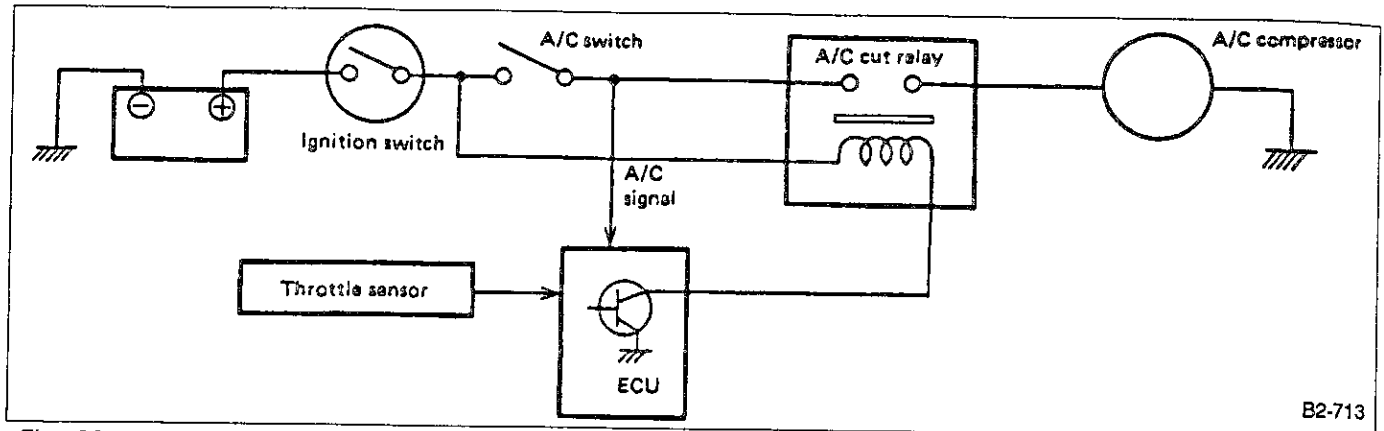
The vehicle speed sensor 2 consists of a magnet rotor which is rotated by a speedometer cable and a read switch. It is built into the combination meter.

One rotation of the magnet rotor turns the read switch on and off four times to produce a digital signal. The digital signal is used as a vehicle speed signal which is transmitted to the ECU.

7. A/C (AIR CONDITIONING) SWITCH AND RELAY

The A/C switch turns the A/C system on or off. The on-off operation of the switch is transmitted to the ECU. The A/C cut relay breaks the current flow to the compressor, through the use of an output signal from the ECU, for a certain period of time when a "full-

throttle" signal (emitted from the throttle sensor) enters the ECU while the compressor is operating. This prevents the degradation of acceleration performance and stabilizes driving performance. This cut relay is installed in the main fuse box located at the left side of the engine compartment.



5. Control System

1. GENERAL

The ECU receives signals sent from various sensors and switches to judge the engine operating condition and emits output signals to provide the optimum control and/or functioning of various systems.

Major items governed by the ECU are as follows:

- Fuel injection control

- Ignition system control
- By-pass air control (idle speed control)
- Canister purge control
- Radiator fan control
- Fuel pump control
- Air conditioner cut control
- Self-diagnosis function
- Fail-safe function

2. INPUT AND OUTPUT SIGNALS

	Unit	Function
Input signal	Air flow sensor	Detects the amount of intake air.
	Throttle sensor	Detects the throttle position.
	Idle switch	Detects a fully-closed throttle.
	O ₂ sensor	Detects the density of O ₂ in exhaust gases.
	Crank angle sensor	Detects engine speed.
	Cam angle sensor	Detects the relative cylinder positions.
	Water temperature sensor	Detects the coolant temperature.
	Knock sensor	Detects engine knocking.
	Vehicle speed sensor 2	Detects vehicle speed.
	Ignition switch	Detects ignition switch operation.
	Starter switch	Detects the condition of engine cranking
	Neutral switch (MT)	Detects shift position "N".
	Inhibitor switch	Detects shift positions "N" and "P".
	A/C switch	Detects the ON-OFF operation of the A/C switch.
Output signal	Fuel injector	Inject fuel.
	Ignition signal	Turns primary ignition current on or off.
	Fuel pump relay	Turns the fuel pump relay on or off.
	Ignition relay	Turns ignition relay on or off.
	A/C cut relay	Turns A/C control relay on or off.
	Radiator fan control relay	Turns radiator fan control relay on or off.
	By-pass air control solenoid valve	Adjusts the amount of by-pass air flowing through the throttle valve.
	Check engine light	Indicates trouble.
	Purge control solenoid valve	Controls the canister purge control.

3. INPUT AND OUTPUT SIGNAL DIAGRAM

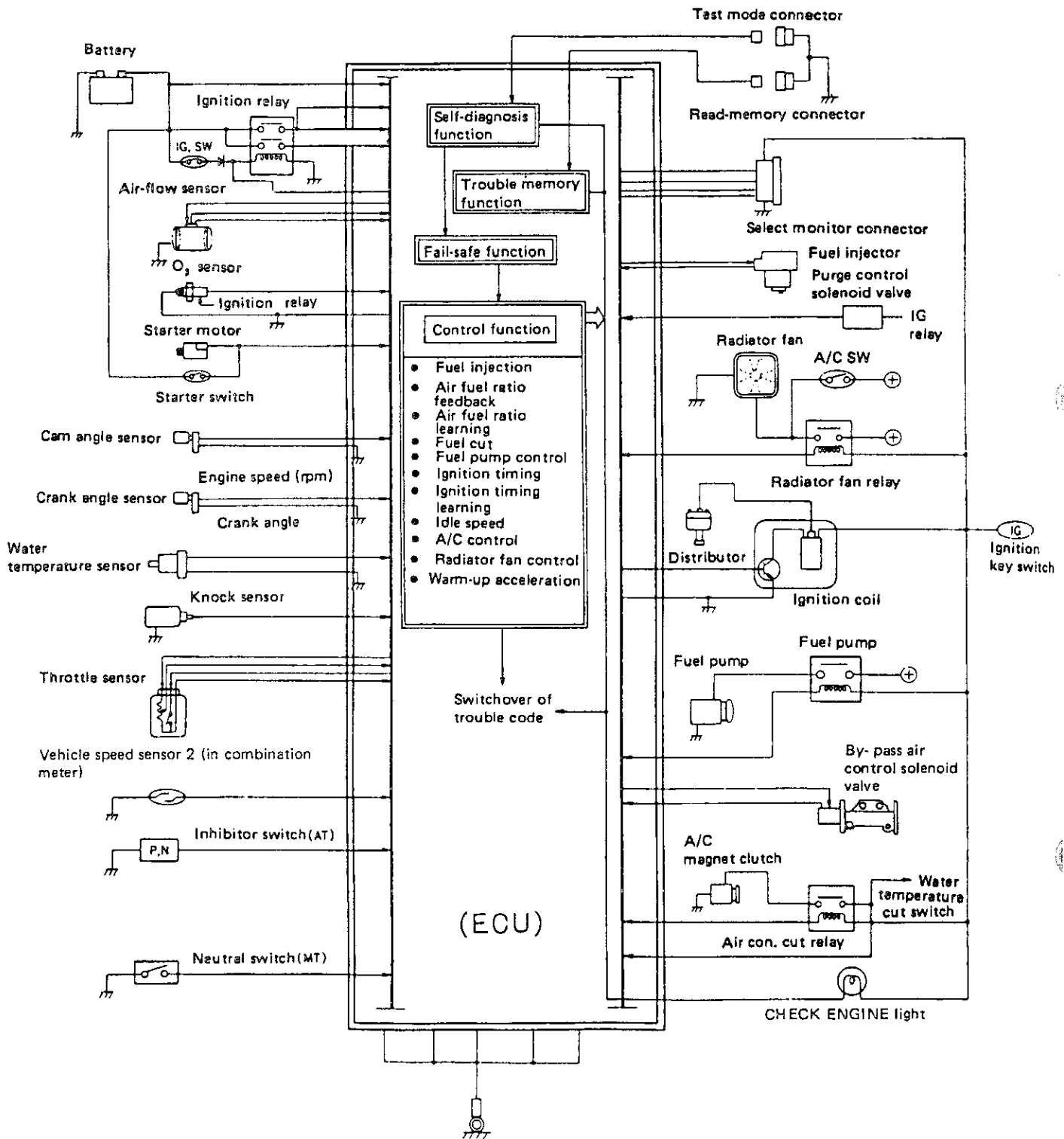


Fig. 21

4. FUEL INJECTION CONTROL

- The amount of fuel to be injected is controlled by using the intake air flowrate monitored by the air flow sensor located in the upstream of the injector body as basic data.
- The fuel injection system is an SPI (single point injection) type. Fuel is injected by a single injector (built into the injection body twice per engine rotation (or once every 180° rotation of the crankshaft)).
- An air-fuel ratio learning control function, which features a high level of accuracy, is used in conjunction with a feedback control function in order to monitor the oxygen density contained in the exhaust gas using the O₂ sensor. The result is that the air-fuel ratio control is highly stabilized and that variations in air-fuel ratio that occur during operation are automatically compensated for.

BASIC INJECTION CHARACTERISTICS

Output pulse width "Ti" is determined by the following equation.

$$Ti = K \times \alpha \times Gf/N + Ts$$

- K: Correction coefficient of fuel injection (Injector coefficient)
- α: Correction coefficient of air-fuel ratio feedback
- Gf: Amount of fuel injected
- N: Engine speed
- Ts: Voltage correction pulse width

1) Amount of fuel injected "Gf"

The amount of fuel injected "Gf" is obtained by multiplying the basic amount of fuel injected (which is determined by the amount of intake air and an engine speed signal) by a correction coefficient (which results from signals sent from various sensors) in order to provide the optimum air-fuel ratio under varying engine operating conditions.

$$Gf = f(Qa, COEF, A/F, X, \tau)$$

- Qa: Intake air flowrate
- A/F: Target air-fuel ratio
- X: Fuel adhesion ratio
- τ: Evaporation time constant

COEF: Correction coefficient

$$COEF = 1 + K_{MR} + K_{WOT} + K_{FULL} + K_{ND} + K_{ACON} + K_{AS}$$

(1) Air-fuel ratio

The target air-fuel ratio is achieved by a signal sent from the water temperature sensor. A stoichiometric mixture ratio of 14.7 is the target value after warming up the engine. When the engine is still cold, the air-fuel ratio will be set to decrease (that is, the mixture is enriched).

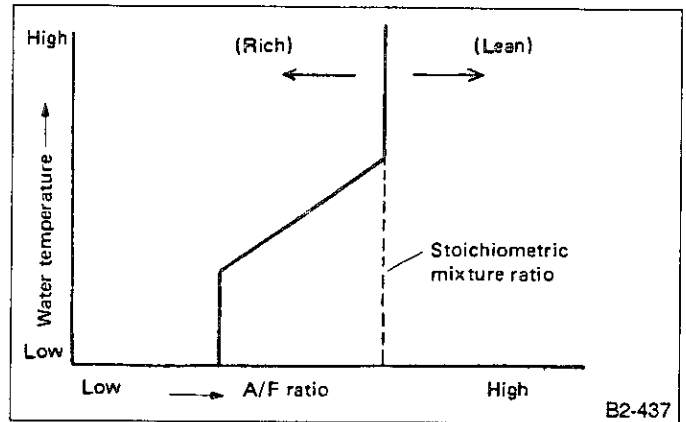


Fig. 22

(2) Fuel adhesion rate "X" and evaporation time constant "τ"

Since the injector is located in the upstream portion of the throttle valve, part of the fuel injected adheres to the throttle valve and the inner wall of the cylinder. When this occurs, the air-fuel ratio will change due to the re-evaporation of the fuel caused by engine heat. Fuel adhesion rate "X" is a predetermined coefficient used to compensate such "fuel-variations" by computing fuel film on the cylinder wall which prevents variations in the mixture (air-fuel ratio) to be drawn in the cylinder.

Fuel adhesion rate "X" is computed based on the relationship of the throttle position and coolant temperature while evaporation time constant "τ" is computed by the amount of intake air, water temperature and engine speed.

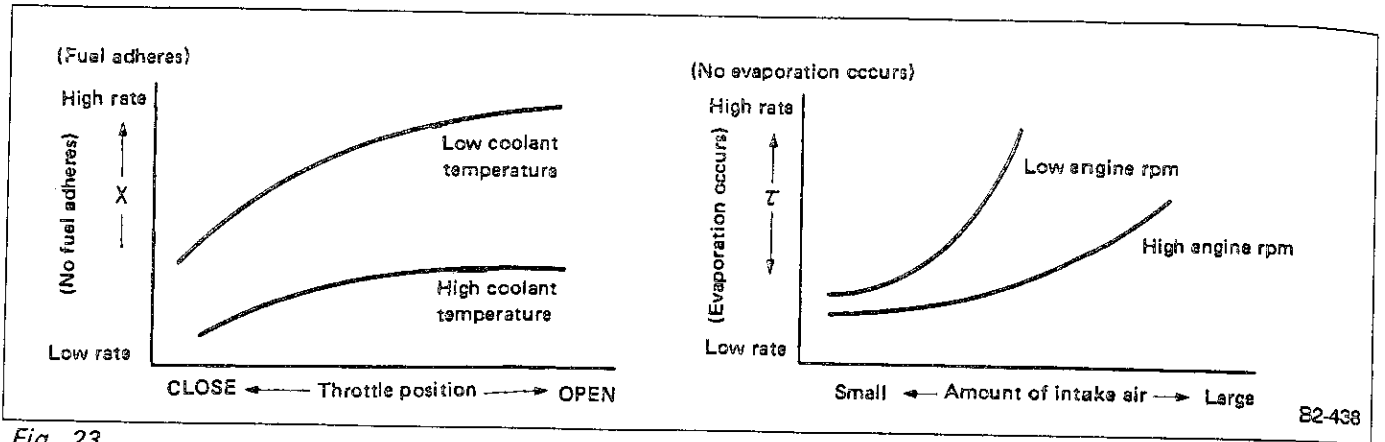


Fig. 23

(3) Air-fuel ratio correction (assignment) coefficient " K_{MR} "

Coefficient " K_{MR} " is assigned to each zone of the relationship between engine rpm and load (the amount of intake air) to provide the adequate air-fuel (mixture) ratio. The amount of fuel injected is determined by the calculation previously outlined. However, a more accurate and precise control of fuel injection is achieved by using coefficient " K_{MR} " in relation to the inherent characteristics of the injector and air flow sensor.

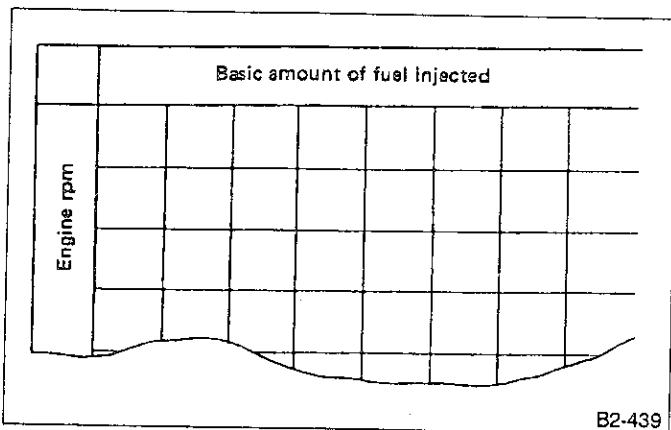


Fig. 24

(4) High-load correction (assignment) coefficient " K_{WOT} "

Coefficient " K_{MR} " is assigned to each throttle position in relation to a signal sent from the throttle sensor. It is used to compensate for variations resulting from inherent characteristics in relation to each throttle position.

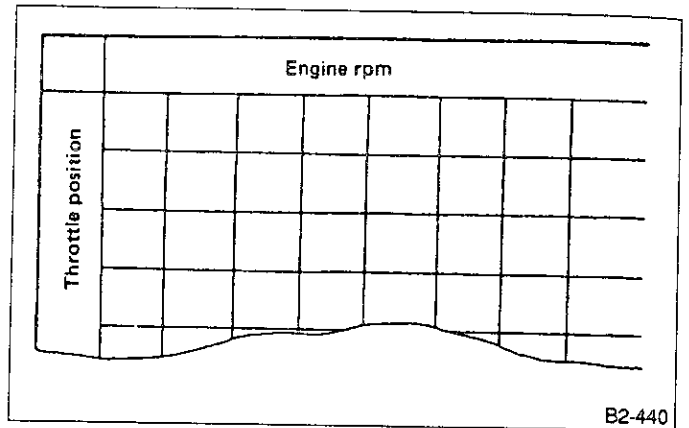


Fig. 25

(5) Full-throttle increment coefficient " K_{FULL} "

Fuel increment is accomplished by judging the full-throttle and power zones resulting from the charging efficiency which is determined by a signal sent from the throttle sensor or hot wire output and engine speed. As a result, zone output performance is achieved.

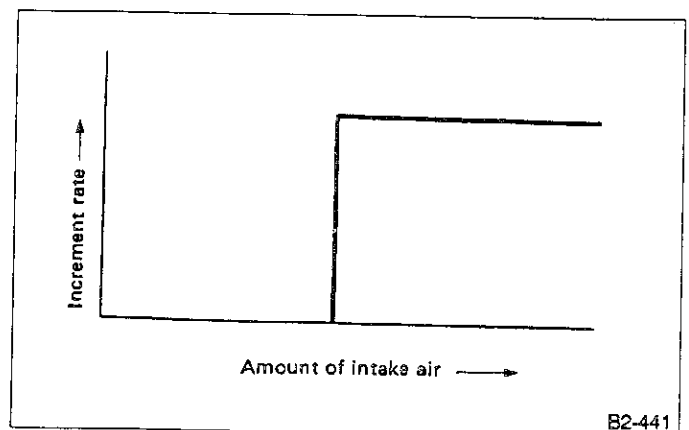


Fig. 26

(6) D range shift increment " K_{ND} " (AT model)

When transmission is shifted to "D" range, fuel increment is accomplished. This prevents a decrease in engine speed when engine is still cold.

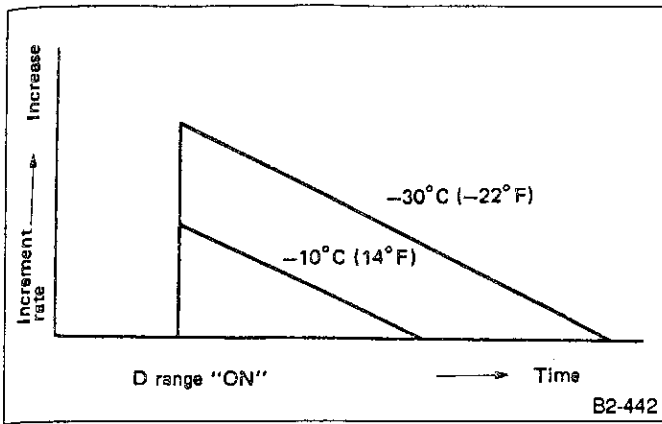


Fig. 27

(7) Air con. ON increment " K_{ACON} "
 Fuel increment is accomplished for a short period of time immediately after A/C switch is turned "ON". This prevents a decrease in engine speed caused by a load variation.

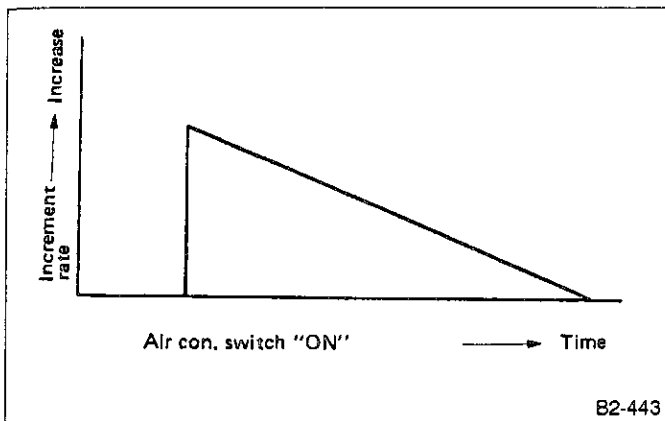


Fig. 28

(8) Start increment coefficient " K_{AS} "
 Increases the amount of fuel injected only when cranking the engine, which improves starting ability.

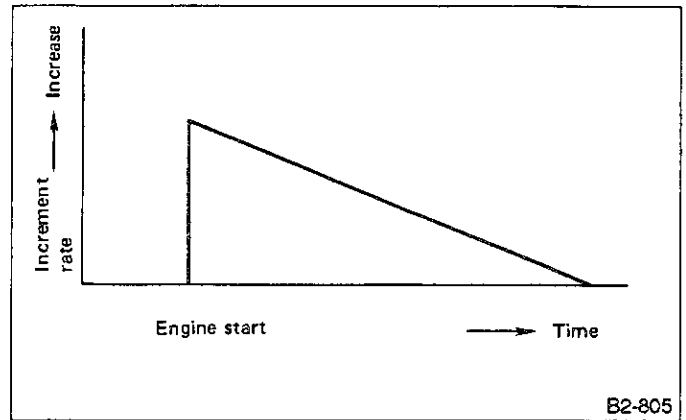


Fig. 29

2) Correction injection coefficient "K"

Correction injection coefficient "K" refers to the injection characteristics of fuel injectors. It is "constant" used to determine the amount of fuel to be injected.

3) Air-fuel ratio feedback coefficient "alpha"

This feedback coefficient utilizes the O₂ sensor's electromotive force (voltage) as a signal to be entered into the ECU. When low voltage is entered, the ECU judges it as a lean mixture, and when high voltage is entered,

it is judged as a rich mixture. In other words, when the air-fuel ratio is richer than the stoichiometric mixture ratio, the amount of fuel injected is decreased. When it is leaner, the amount of fuel injected is increased. In this way, the air-fuel ratio is compensated so that it comes as close to the stoichiometric mixture ratio as possible on which the three-way catalyst acts most effectively. (CO, HC and NO_x are also reduced when the air-fuel ratio is close to stoichiometric mixture ratio.)

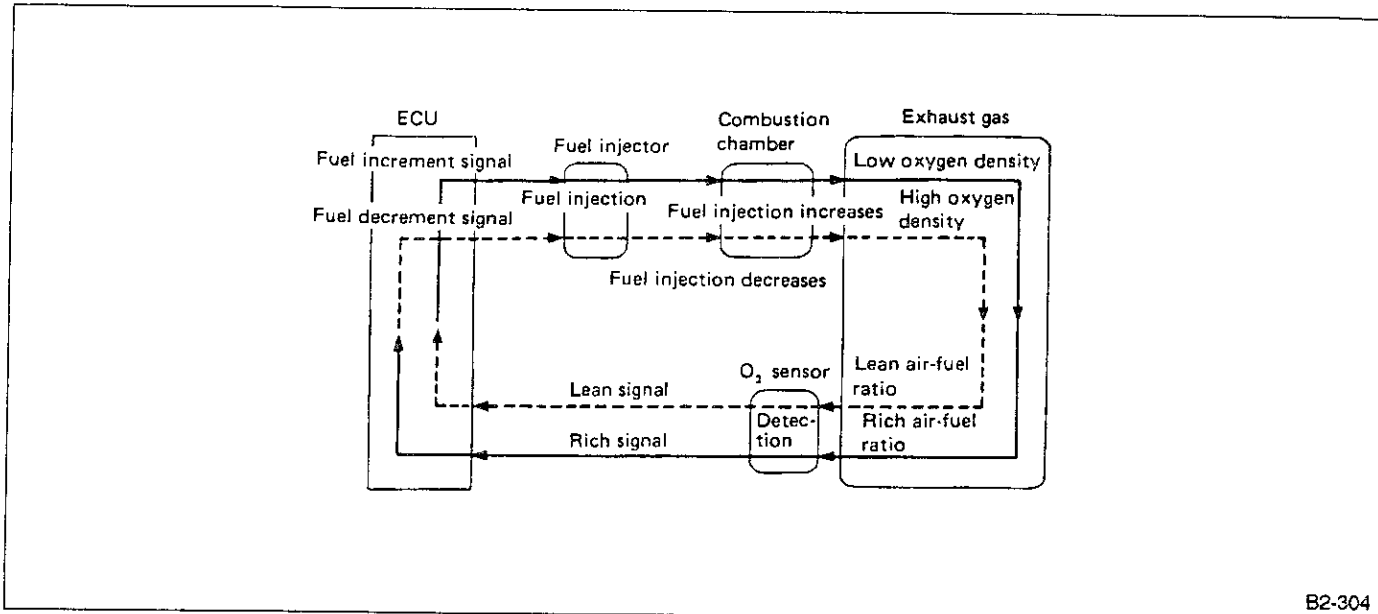


Fig. 30

4) Learning control system

In a conventional air-fuel feedback control system, the basic amount of fuel injected (according to engine speed and various loads) is stored in the memory. After the ECU receives a signal emitted from the O₂ sensor, the basic amount of fuel injected is corrected so that it is close to the stoichiometric mixture ratio. This means that the greater the air-fuel ratio is corrected, the lesser the control accuracy.

In SUBARU engines, however, an air-fuel ratio learning control system constantly memorizes the amount of correction required in relation to the basic amount of fuel to be injected (the basic amount of fuel injected is determined after several cycles of fuel injection), so that the correction affected by feedback control is minimized. Thus, quick response and accurate control of variations in air-fuel ratio, sensors' and actuators' characteristics during operation, as well as in the air-fuel ratio with the time of engine operation, are achieved. In addition, accurate control contributes much to stability of exhaust gases and driving performance.

5. IGNITION SYSTEM CONTROL

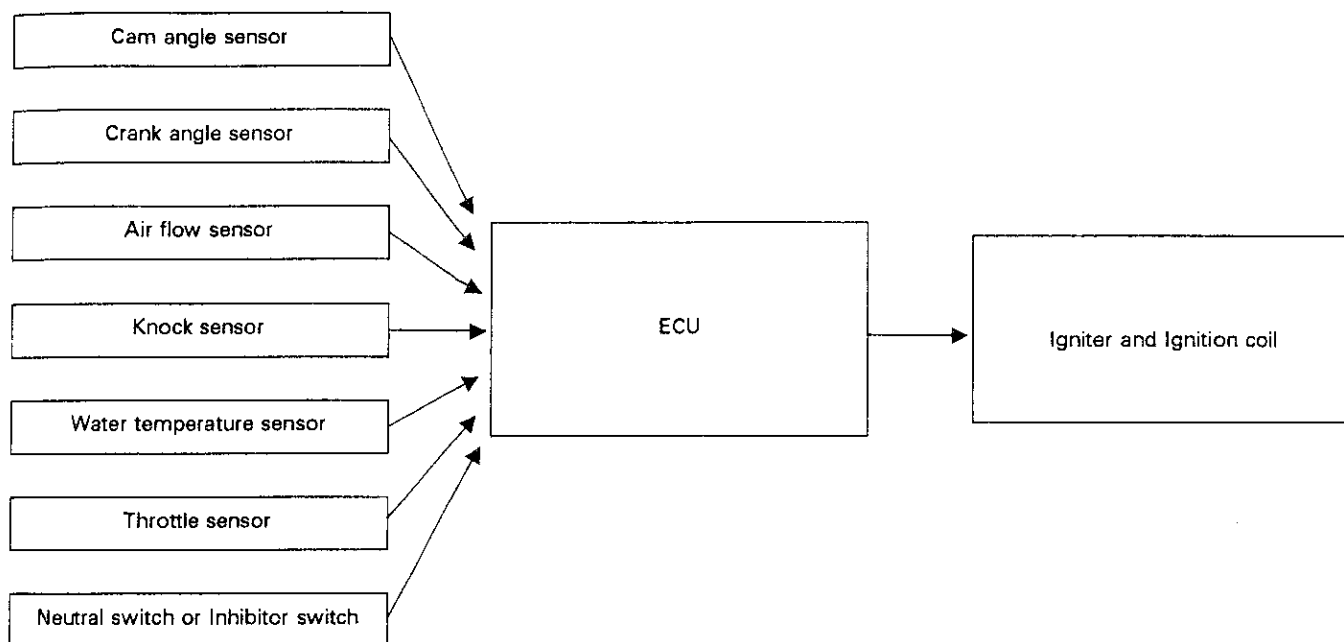
The ECU receives signals emitted from the air flow sensor, water temperature sensor, crank angle sensor, cam angle sensor, knock sensor, etc., to judge the operating condition of the engine. It then selects the optimum ignition timing stored in the memory and immediately transmits a primary current OFF signal to the igniter to control the ignition timing.

While the ECU receives signals emitted from the knock sensor, it is controlled so that advanced ignition timing is maintained immediately before engine knock occurs.

This system control type features a quick-to-response learning control method by which data stored in the ECU memory is processed in comparison with information emitted from various sensors and switches.

Thus, the ECU constantly provides the optimum ignition timing in relation to output, fuel consumption, exhaust gas, etc., according to various engine operating conditions, the octane rating of the fuel used, etc.

This eliminates the distributor and achieves maintenance-free operation.



1) Normal advance angle

The upper and lower limits of advance angle for ignition timing are previously stored in the 16-grid map of the ECU's memory in response to the amount of intake air and engine speed. The ECU learns the status of fuel octane rating and changes in engine operation with elapse of time from signals sent from air flow sensor, cam-angle sensor, crank-angle sensor and knock sensor in order to determine an optimal ignition timing map.

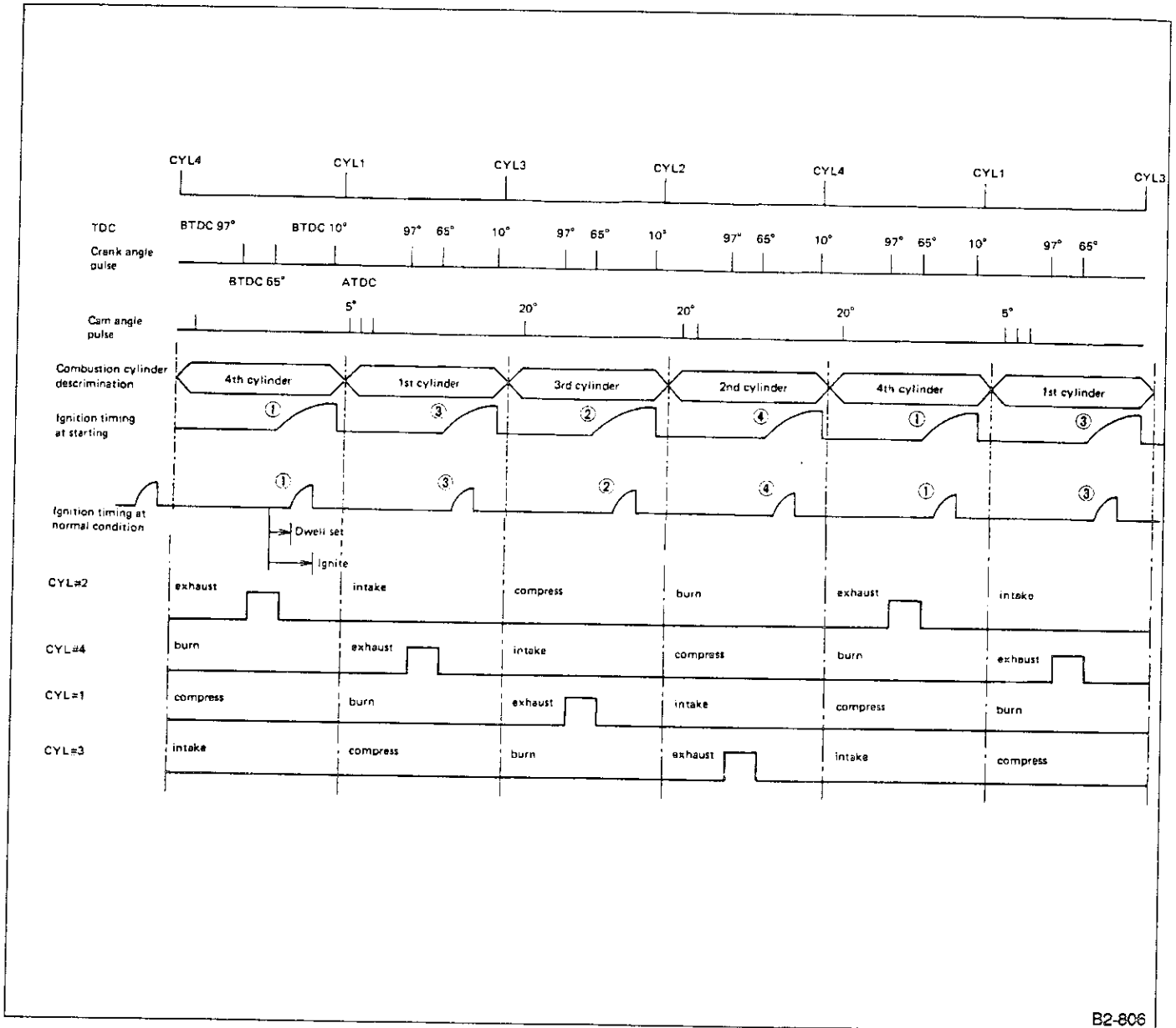
Advance angles for spark ignition are as follows:

2) Idle advance angle

Idle advance angle is controlled by ECU to provide optimal ignition.

3) Spark advance angle characteristics during low speeds

Ignition advance angle during low engine speeds is controlled to 10° BTDC (before top dead center) by ECU. It will return to normal advance angle after engine speed exceeds a specifications.



B2-806

Fig. 31

6. BY-PASS AIR CONTROL (IDLE SPEED CONTROL)

The ECU activates the by-pass air control solenoid valve in advance to control the amount of by-pass air flowing through the throttle valve in relation to signals emitted from the crank angle sensor, cam angle sensor, water temperature sensor and A/C switch, so that the proper idle speed specified for each engine load is achieved.

The by-pass air control solenoid valve utilizes a duty solenoid design so that the amount of valve "lift" is determined by a certain operating frequency. For this reason, the by-pass air flow is regulated by controlling the duty ratio. The relationship between the duty ratio, valve lift and by-pass air flow is as follows:

Duty ratio (high) → Increases valve lift and by-pass air flow.

Bypass air control features the following advantages:

1. Compensation for engine speed under A/C (air conditioning) system and electrical loads.
2. Increase in idle speed during early stage of warm-up period.
3. Prevention of idle speed increases after engine warm-up.
4. A dashpot function during the time the throttle valve is quickly closed.
5. Prevention of engine speed variations over time.

Diagram

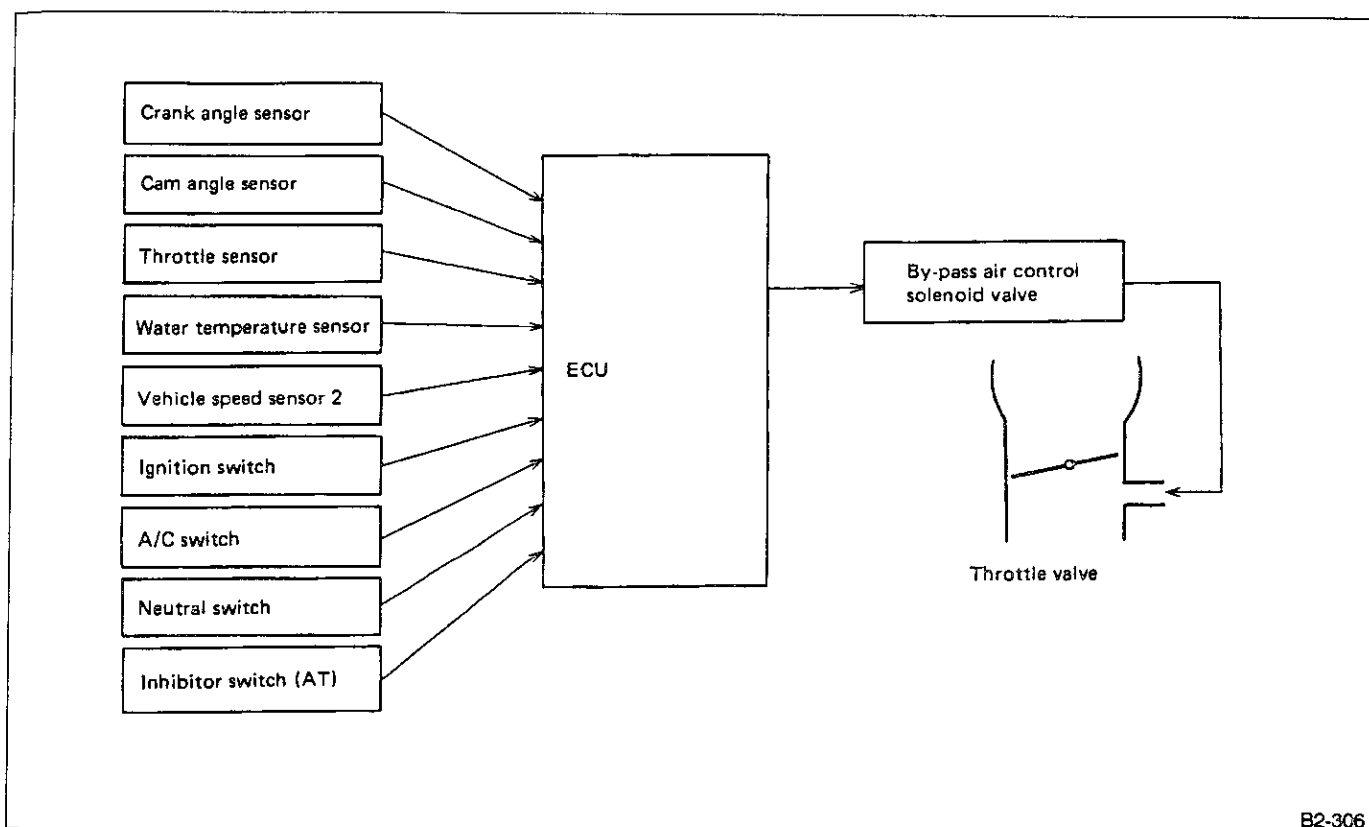


Fig. 32

7. CANISTER PURGE CONTROL

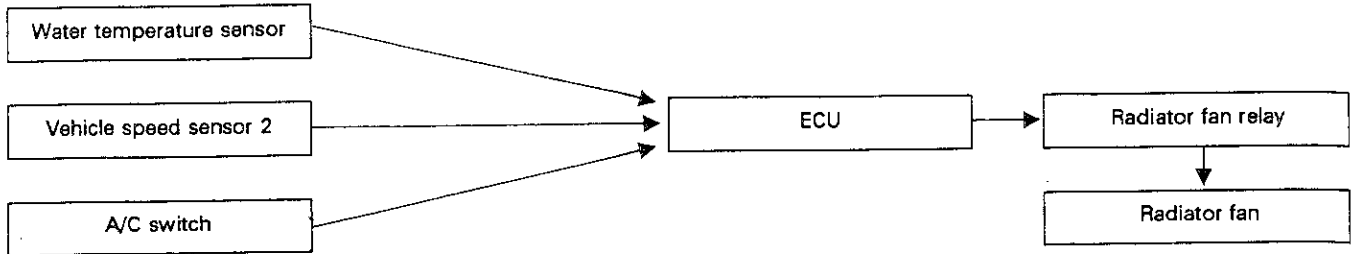
The ECU receives signals emitted from the water temperature sensor, vehicle speed sensor 2 and crank angle sensor to control the purge control solenoid valve.

Canister purge takes place during operation of the vehicle except under certain conditions (during idle, etc.). The purge line is connected to the throttle chamber to purge fuel evaporation gas from the canister according to the amount of intake air.

8. RADIATOR FAN CONTROL

The ON-OFF control of the radiator fan (for models which are not equipped with an air conditioning system) is governed by the ECU which receives signals sent from the water temperature sensor and vehicle speed sensor 2. On models which are equipped with an

air conditioning system, the ECU receives signals sent from the water temperature sensor, vehicle speed sensor 2 and A/C switch. These signals simultaneously turn ON or OFF the main radiator fan and A/C subfan as well as setting them at "HI" or "LO" speed.

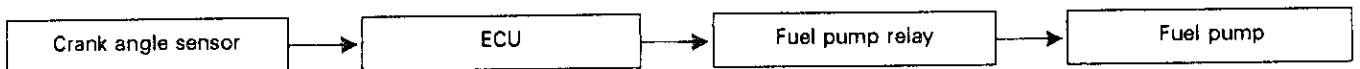


9. FUEL PUMP CONTROL

The ECU receives a signal emitted from the crank angle sensor and turns the fuel pump relay ON or OFF to control fuel pump operation. To improve safety, the fuel

pump will stop if the engine stalls with the ignition switch ON.

Ignition switch ON	Fuel pump relay	Fuel pump
A certain period of time (after ignition switch is turned ON)	ON	Operates
While cranking the engine	ON	Operates
While engine is operating	ON	Operates
When engine stops	OFF	Does not operate



10. A/C CUT CONTROL

When the ECU receives a "full-open" signal emitted from the throttle sensor while the air conditioning system is operating, the A/C cut relay turns off for a certain

period of time to stop the compressor. This prevents degradation of output during acceleration and stabilizes driveability.

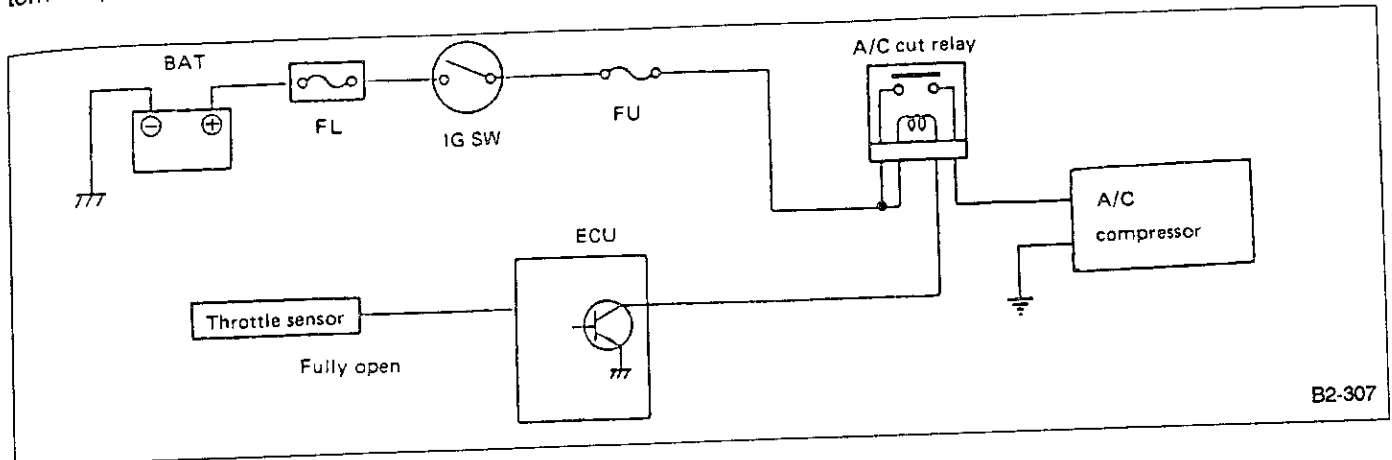
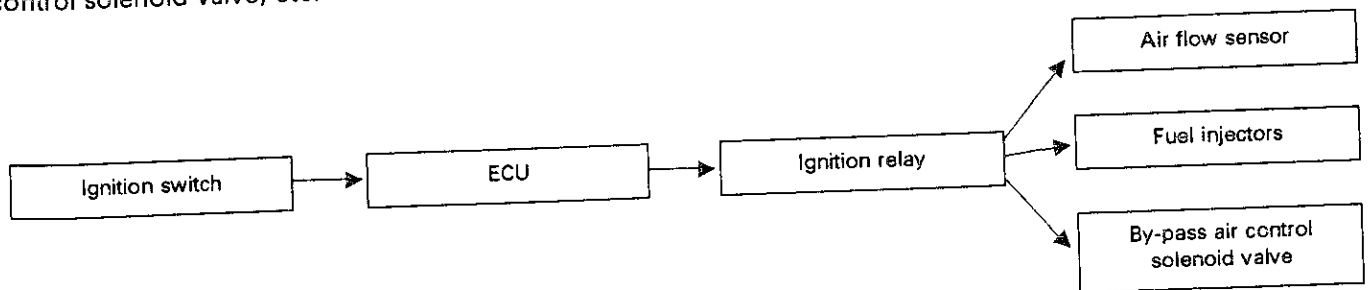


Fig. 33

11. POWER SUPPLY CONTROL

When the ECU receives an ON signal emitted from the ignition switch, current flows through the ignition relay. This turns the ignition relay ON so that power is supplied to the fuel injectors, air flow sensor, by-pass air control solenoid valve, etc.

Power to the above parts except the fuel injectors is turned off five seconds after the ECU receives an OFF signal from the ignition switch. The fuel injectors stop fuel injection immediately after the ignition switch is turned OFF because the injection signal is cut off.



6. Self-diagnosis System

1. GENERAL

The self-diagnosis system detects and indicates a fault in various inputs and outputs of the complex electronic control. The warning light (CHECK ENGINE light) on the instrument panel indicates occurrence of a fault or trouble, and also the light emitting diode (LED) in the ECU indicates a trouble code.

Further, against such a failure or sensors as may disable the drive, the fail-safe function is provided to ensure the minimal driveability.

2. FUNCTION OF SELF-DIAGNOSIS

The self-diagnosis function has four modes: U-check mode, Read memory mode, D-check mode and Clear memory mode. Two connectors (Read memory and Test mode) and a light (CHECK ENGINE light) are used. The connectors are for mode selection and the light monitors the type of problem.

- Relationship between modes and connectors

Mode	Engine	Read memory connector	Test mode connector
U-check	Ignition ON	DISCONNECT	DISCONNECT
Read memory	Ignition ON	CONNECT	DISCONNECT
D-check	Ignition ON (engine on)	DISCONNECT	CONNECT
Clear memory	Ignition ON (engine on)	CONNECT	CONNECT

- U-check mode

The U-check is a user-oriented mode in which only the MPFI components necessary for start-up and drive are diagnosed. On occurrence of a fault, the warning light (CHECK ENGINE light) is lighted to indicate to the user that the dealer's inspection is necessary. The diagnosis of other parts which do not give significant adverse effect to start-up and drive are excluded from this mode in order to avoid unnecessary uneasiness to be taken by the user.

- Read memory mode

This mode is used by the dealer to read past problems (even when the vehicle's monitor lights are off). It is most effective in detecting poor contact or loose connections of connectors, harnesses, etc.

- D-check mode

This mode is used by the dealer to check the entire MPFI system and detect faulty parts.

- Clear memory mode

This mode is used by the dealer to clear the trouble code from the memory after the affected part is repaired.

3. BASIC OPERATION OF SELF-DIAGNOSIS SYSTEM

● No TROUBLE

Mode	Read memory connector	Test mode connector	Condition	CHECK ENGINE light
U-check	X	X	Ignition switch ON (Engine OFF)	ON
			Engine ON	OFF
Read memory	○	X	Ignition switch ON (Engine OFF)	Blink
			Engine ON	
D-check	X	○	Ignition switch ON (Engine OFF)	ON
			Engine ON	OFF → Blink*
Clear memory	○	○	Ignition switch ON (Engine OFF)	ON
			Engine ON	OFF → Blink*

● TROUBLE

Mode	Read memory connector	Test mode connector	Condition	CHECK ENGINE light
U-check	X	X	Ignition switch ON	ON
Read memory	○	X	Ignition switch ON (Engine OFF)	Trouble code (memory)
			Engine ON	ON
D-check	X	○	Engine ON	Trouble code**
Clear memory	○	○	Engine ON	Trouble code**

* When the engine operates at a speed greater than 2,000 rpm for more than 40 seconds, the check engine light blinks. However, when all check items check out "O.K.", even before the 40 seconds is reached, the check engine light blinks.

** When the engine operates at a speed greater than 2,000 rpm for more than 40 seconds, a trouble code is emitted.

4. FAIL-SAFE FUNCTION

For the part which has been judged faulty in the self-diagnosis, the ECU generates the associated pseudo signal (only when convertible to electric signal) and carries out the computational processing. In this fashion, the fail-safe function is performed.

5. TROUBLE CODES AND FAIL-SAFE OPERATION

Trouble code	Item	Contents of diagnosis	Fail-safe operation
11	Crank angle sensor	No signal entered from crank angle sensor, but signal (corresponding to at least one rotation of crank) entered from cam angle sensor.	—
12	Starter switch	Abnormal signal emitted from ignition switch.	Sets starter switch signal OFF.
13	Cam angle sensor	No signal entered from cam angle sensor, but signal (corresponding to at least two rotations of cam) entered from crank angle sensor.	—
14	Injector	Fuel injector inoperative. (Abnormal signal emitted from monitor circuit.)	—
21	Water temperature sensor	Abnormal signal emitted from water temperature sensor.	Adjusts water to a specific temperature. Maintains radiator fan "ON" to prevent overheating.
22	Knock sensor	Abnormal voltage produced in knock sensor monitor circuit.	Sets in regular fuel map.
23	Air flow sensor	Abnormal voltage input entered from air flow sensor.	Controls the amount of fuel (injected) in relation to engine speed and throttle sensor position.
24	By-pass air control solenoid valve	Solenoid valve inoperative. (Abnormal signal produced in monitor circuit.)	Prevents abnormal engine speed using "fuel cut" in relation to engine speed, vehicle speed and throttle sensor position.
31	Throttle sensor	Abnormal voltage input entered from throttle sensor.	Sets throttle sensor's voltage output to a fixed value.
32	O ₂ sensor	O ₂ sensor inoperative.	—
33	Vehicle speed sensor 2	Abnormal voltage input entered from vehicle speed sensor.	Sets vehicle speed signal to a fixed value.
35	Purge control solenoid valve	Solenoid valve inoperative.	—
42	Idle switch	Abnormal voltage input entered from idle switch.	Judges ON or OFF operation according to throttle sensor's signal.
51	Neutral switch (MT)	Abnormal signal entered from neutral switch.	—
51	Inhibitor switch (AT)	Abnormal signal entered from inhibitor switch.	—

T TROUBLESHOOTING

1. Precautions

- 1) Never connect the battery in reverse polarity.
 - The SPFI control unit will be destroyed instantly.
 - The fuel injector and other part will be damaged in just a few minutes more.
- 2) Do not disconnect the battery terminals while the engine is running.
 - A large counter electromotive force will be generated in the alternator, and this voltage may damage electronic parts such as ECU (SPFI control unit), etc.
- 3) Before disconnecting the connectors of each sensor and the ECU, be sure to turn off the ignition switch.
 - Otherwise, the ECU may be damaged.
- 4) The connectors to each sensor in the engine compartment and the harness connectors on the engine side and body side are all designed to be waterproof. However, it is still necessary to take care not to allow water to get into the connectors when washing the vehicle, or when servicing the vehicle on a rainy day.
- 5) Every SPFI-related part is a precision part. Do not drop them.
- 6) Observe the following cautions when installing a radio in SPFI equipped models.
 - a. The antenna must be kept as far apart as possible from the control unit.
(The ECU is located under the steering column, inside of the instrument panel lower trim panel.)
 - b. The antenna feeder must be placed as far apart as possible from the ECU and SPFI harness.
 - c. Carefully adjust the antenna for correct matching.
 - d. When mounting a large power type radio, pay special attention to items a. through c. above.
 - Incorrect installation of the radio may affect the operation of the ECU.
- 7) Before disconnecting the fuel hose, disconnect the fuel pump connector and crank the engine for more than five seconds to release pressure in the fuel system. If engine starts during this operation, run it until it stops.

2. Pre-inspection

Before troubleshooting, check the following items which might affect engine problems:

1. POWER SUPPLY

- 1) Measure battery voltage and specific gravity of electrolyte.

Standard voltage: 12 V

Specific gravity: Above 1.26

- 2) Check the condition of the main and other fuses, and harnesses and connectors. Also check for proper grounding.

2. CAPS AND PLUGS

- 1) Check that the fuel cap is properly closed.
- 2) Check that the oil filler cap is properly closed.
- 3) Check that the oil level gauge is properly inserted.

3. INTAKE MANIFOLD VACUUM PRESSURE

- 1) After warming up the engine, measure intake manifold vacuum pressure while at idle.

Standard vacuum pressure:

More than - 60.0 kPa (- 450 mmHg, - 17.72 inHg)

- 2) Unusual vacuum pressure occurs because of air leaks, fuel or engine problems. In such a case, engine idles roughly.

4. FUEL PRESSURE

- 1) Fuel pressure elimination
 - (1) Disconnect the fuel pump connector.
 - (2) Start the engine.
 - (3) Leave the engine until it stalls.
 - (4) After it stalls, crank the starter for approximately 5 seconds and turn the ignition switch to "OFF".
- 2) Fuel pressure gauge installation
 - (1) Connect a fuel pressure gauge between the fuel strainer and the fuel hose.
 - (2) Connect the fuel pump connector.
- 3) Fuel pressure measurement
 - (1) Start the engine. Measure fuel pressure while allowing the engine to idle.

Fuel pressure:

Approx. 255 kPa (2.6 kg/cm², 37 psi)

- (2) Race the engine to ensure that fuel pressure increases.
- (3) Stop the engine and connect the D-check connector. Turn the ignition switch to "ON" (engine "OFF") and measure fuel pressure.

Fuel pressure:

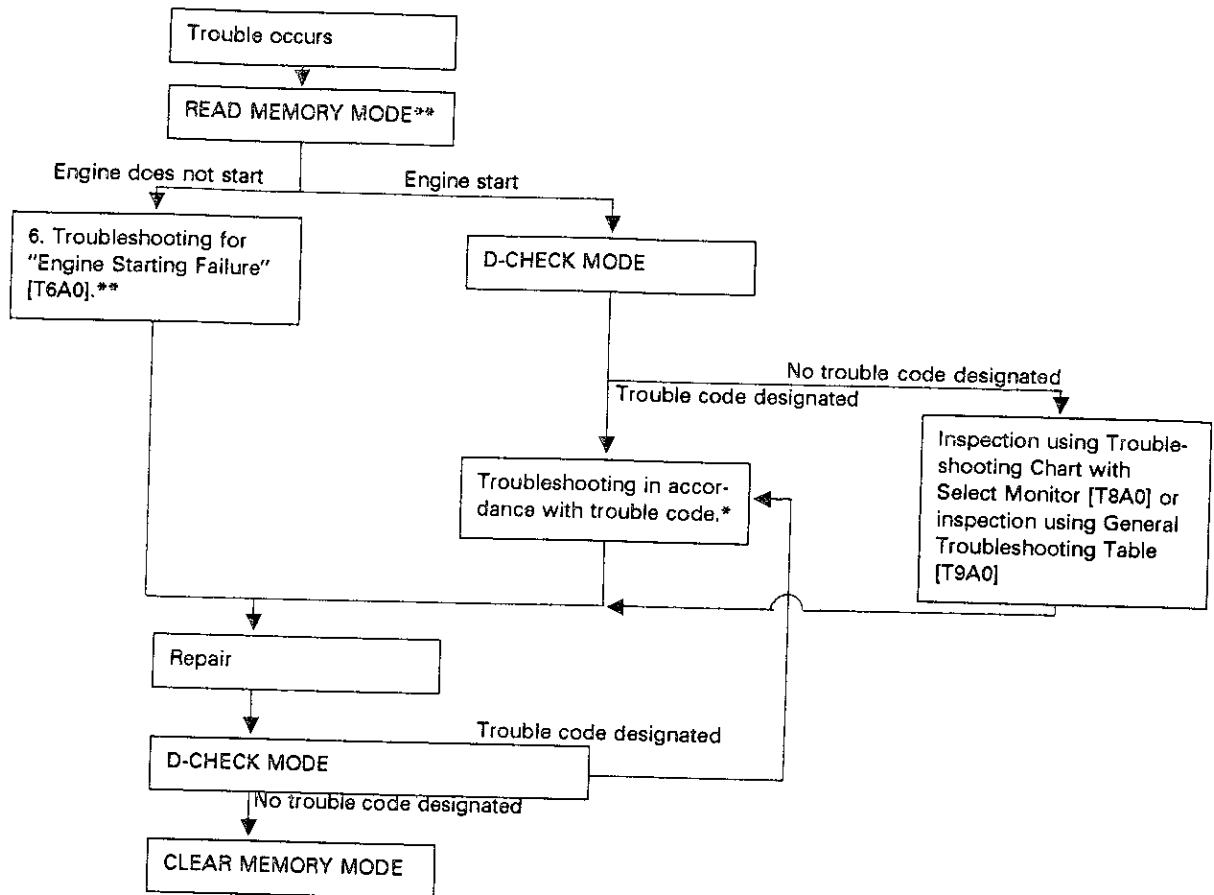
235 - 255 kPa (2.4 - 2.6 kg/cm², 34 - 37 psi)

5. ENGINE GROUNDING

Make sure the engine grounding terminal is properly connected to the engine.

3. Troubleshooting Chart for Self-diagnosis System

A: BASIC TROUBLESHOOTING PROCEDURE



*: When more than one trouble code is outputted, begin troubleshooting with the smallest trouble code number and proceed to the next higher code.

After correcting each problem, conduct the D-check and ensure that the corresponding trouble code no longer appears.

** : When a trouble code is displayed in the read memory mode, conduct troubleshooting measures which correspond with the code.

a. Check the connector while it is connected unless specified otherwise.

b. Be sure to check again from the beginning in order to prevent secondary trouble caused by repair work.

c. When checking with the vacuum hose disconnected from the vacuum switch at engine ON, be sure to plug the hose.

B: LIST OF TROUBLE CODE

1. TROUBLE CODE

Trouble code	Item	Content of diagnosis
11.	Crank angle sensor	No signal entered from crank angle sensor, but signal entered from cam angle sensor.
12.	Starter switch	Abnormal signal emitted from ignition switch.
13.	Cam angle sensor	No signal entered from cam angle sensor, but signal entered from crank angle sensor.
14.	Injector	Fuel injector inoperative. (Abnormal signal emitted from monitor circuit.)
21.	Water temperature sensor	Abnormal signal emitted from water temperature sensor.
22.	Knock sensor	Abnormal voltage produced in knock sensor monitor circuit.
23.	Air flow sensor	Abnormal voltage input entered from air flow sensor.
24.	By-pass air control solenoid valve	Solenoid valve inoperative. (Abnormal signal emitted from monitor circuit.)
31.	Throttle position sensor	Abnormal voltage input entered from throttle sensor.
32.	O ₂ sensor	O ₂ sensor inoperative.
33.	Vehicle speed sensor 2	Abnormal voltage input entered from speed sensor.
35.	Purge control solenoid valve	Solenoid valve inoperative.
42.	Idle switch	Abnormal voltage input entered from idle switch.
51.	Neutral switch (MT)	Abnormal signal entered from neutral switch.
51.	Inhibitor switch (AT)	Abnormal signal entered from inhibitor switch.

2. HOW TO READ TROUBLE CODE (FLASHING)

The CHECK ENGINE light flashes the code corresponding to the faulty part.

The long segment (1.2 sec on) indicates a "ten", and the short segment (0.2 sec on) signifies "one".

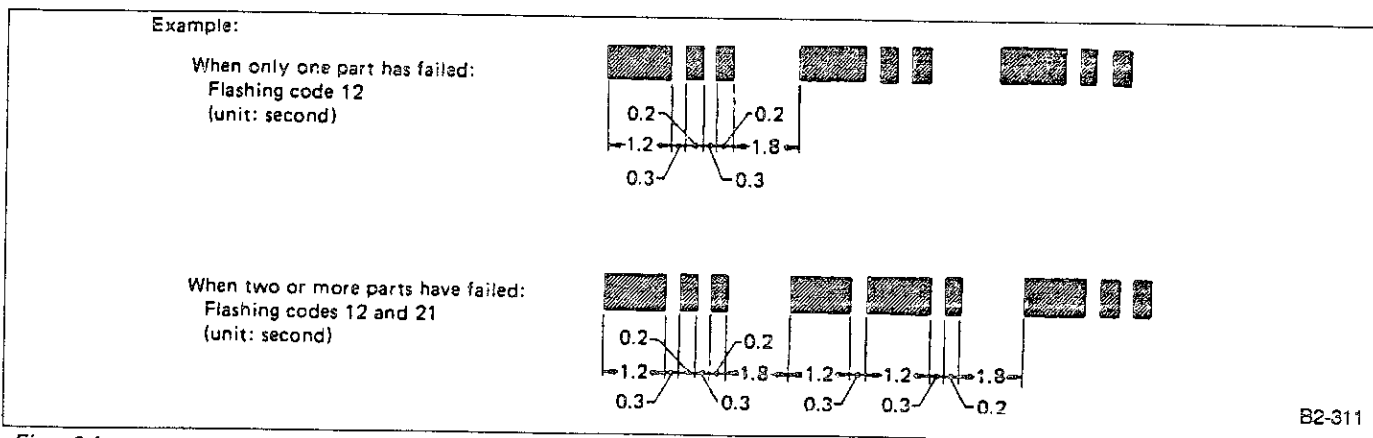
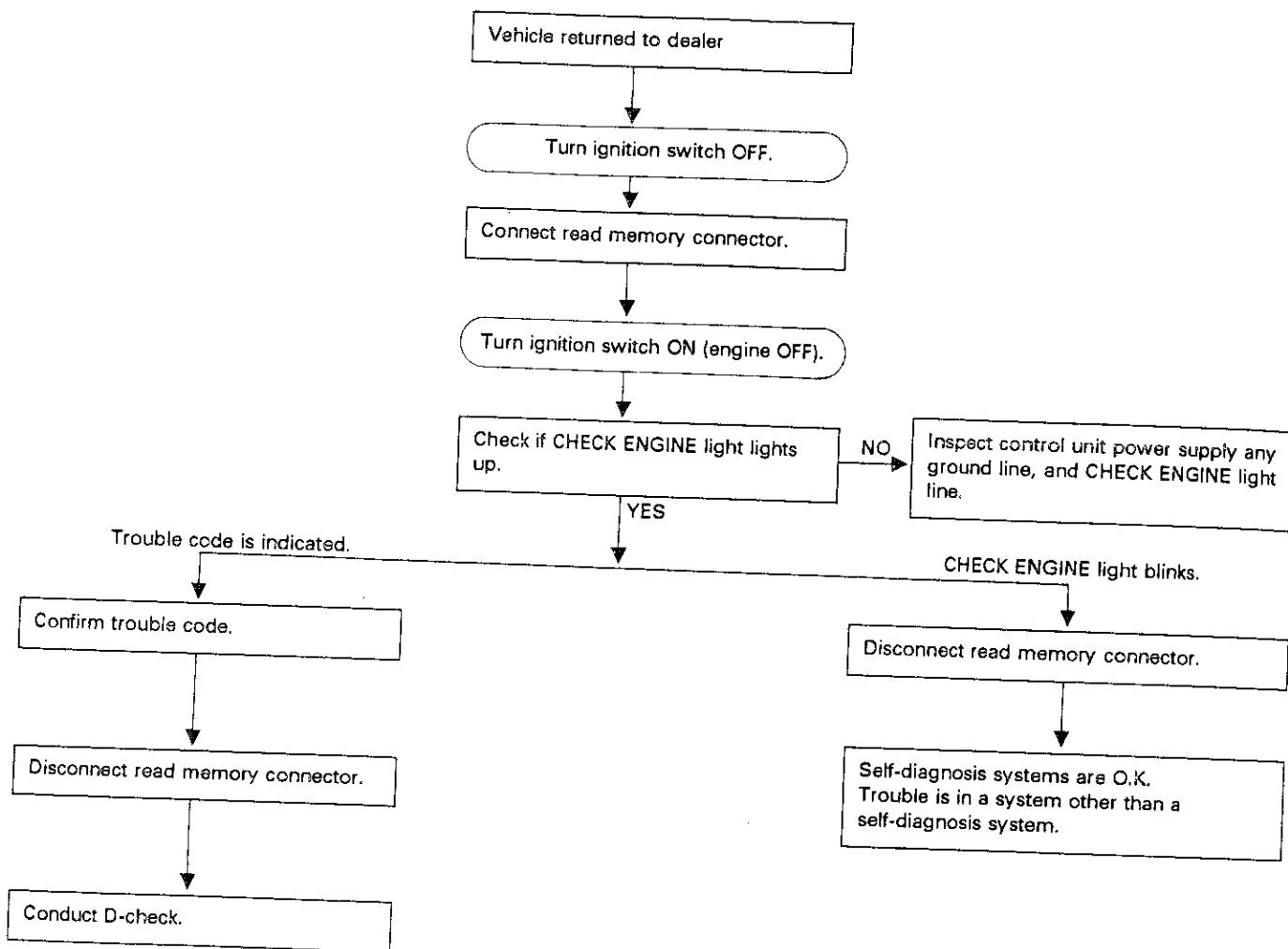
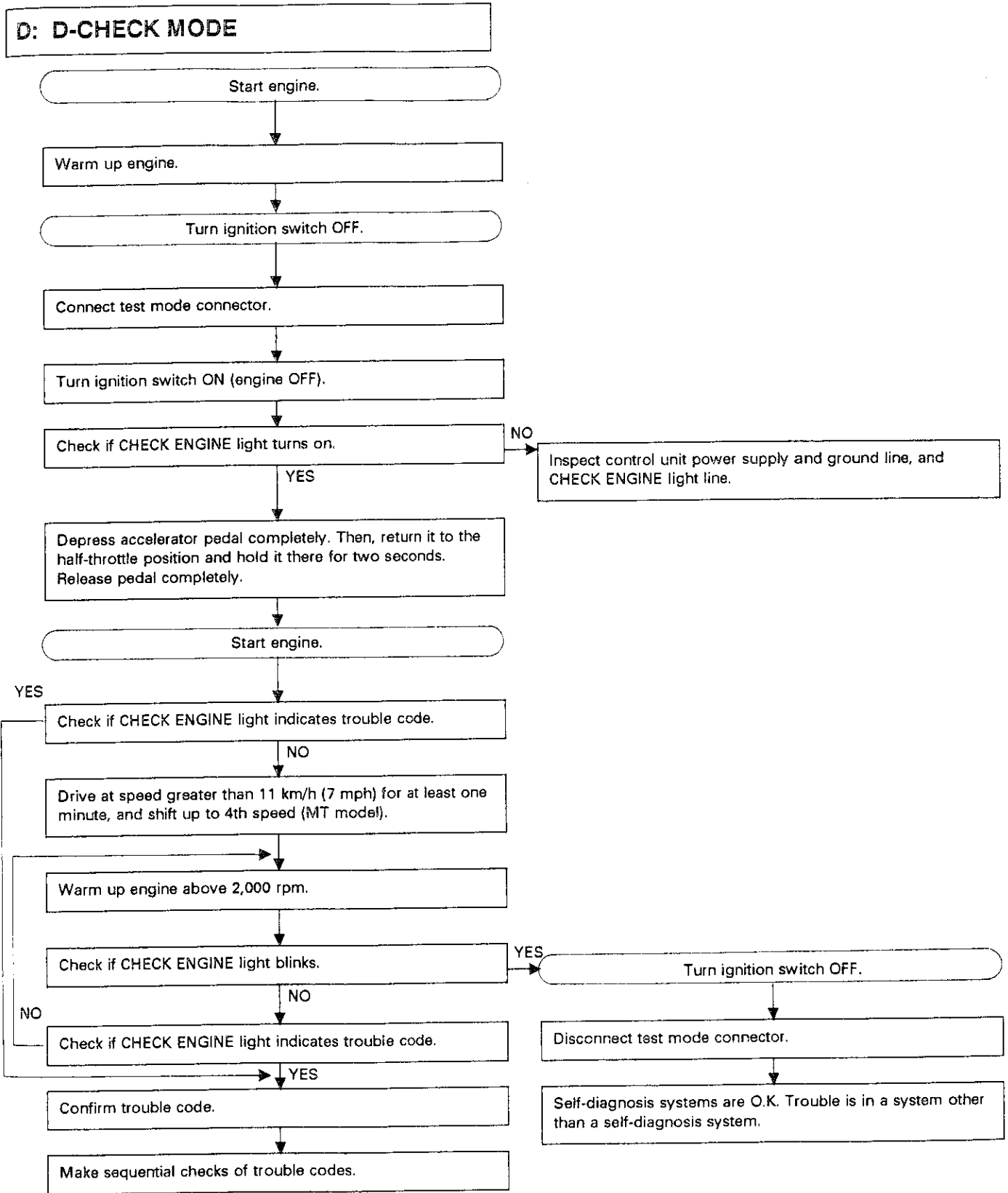


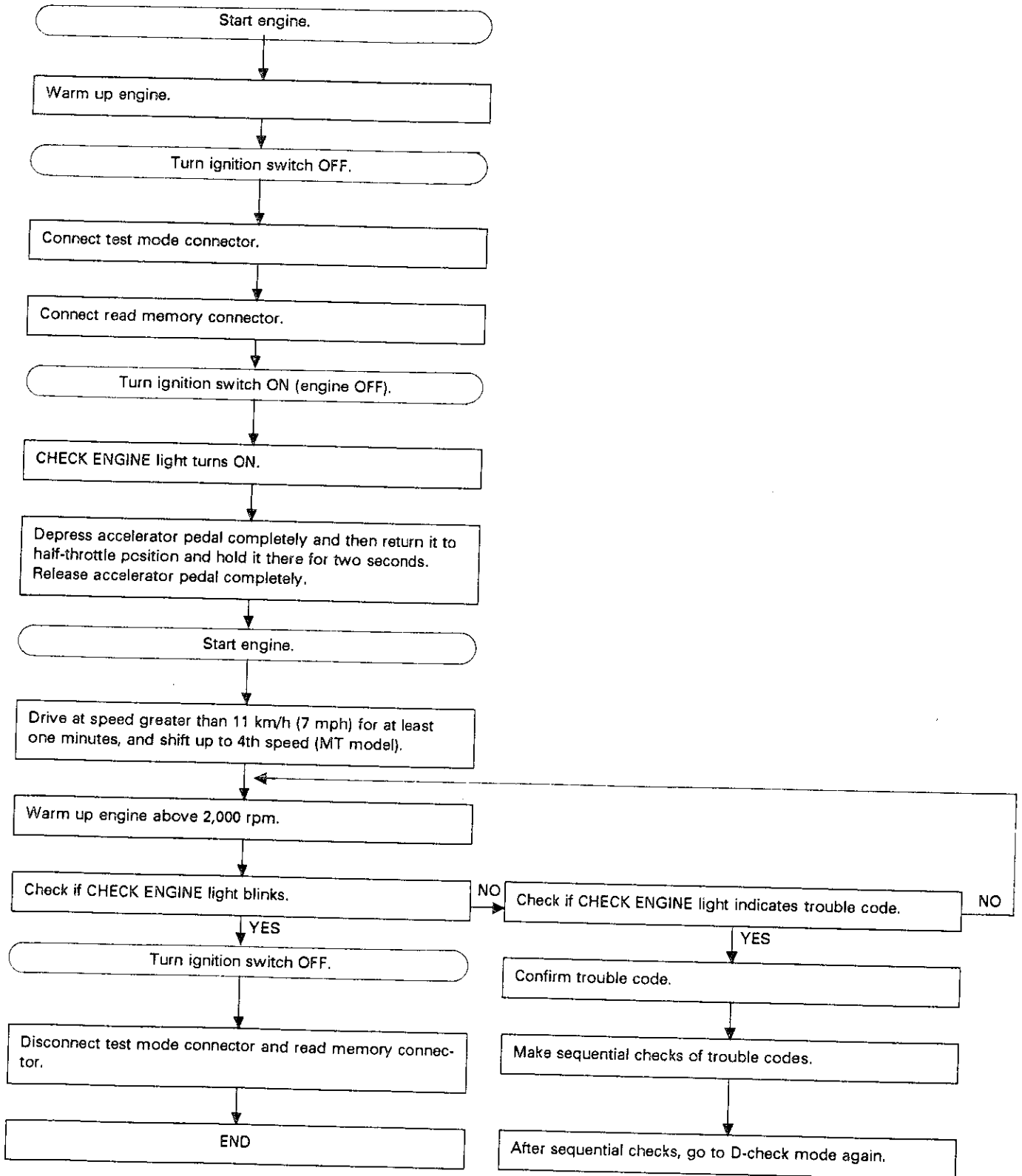
Fig. 34

C: READ MEMORY MODE





E: CLEAR MEMORY MODE



4. Output Modes of Select Monitor

1. FUNCTION MODE

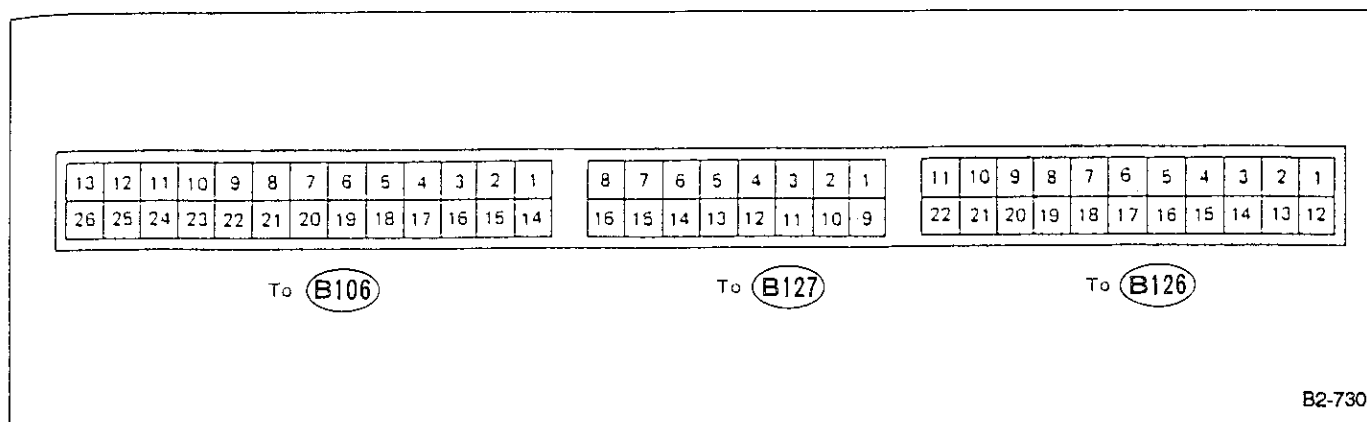
Applicable cartridge of select monitor: No. 498348800

MODE	Contents	Abbr.	Unit	Contents of display
F00	PROM ID Number	YEAR	—	Model year of vehicle to which select monitor is connected
F01	Battery Voltage	VB	V	Battery voltage supplied to control unit
F02	Vehicle Speed Sensor 2	VSP	MPH	Vehicle speed inputted from vehicle speed sensor
F03	Vehicle Speed Sensor 2	VSP	km/h	Vehicle speed inputted from vehicle speed sensor
F04	Engine speed	EREV	rpm	Engine speed inputted from crank angle sensor
F05	Water Temp. Sensor	TW	deg F	Coolant temperature inputted from water temperature sensor
F06	Water Temp. Sensor	TW	deg C	Coolant temperature inputted from water temperature sensor
F07	Ignition Timing	ADVS	deg	Ignition timing determined by ECU in relation to signals sent from various sensors
F08	Air Flow Sensor	QA	V	Voltage inputted from air flow meter
F09	Load Data	LDATA	—	Engine load value determined by related sensor signals
F10	Throttle Sensor	THV	V	Voltage inputted from throttle position sensor
F11	Injector Pulse Width	TIM	mS	Duration of pulse flowing through injectors
F12	By-pass air control solenoid valve	ISC	%	"Duty" ratio flowing through solenoid valve
F13	O ₂ Sensor	O ₂	V	Voltage outputted from O ₂ sensor
F14	O ₂ Max	O ₂ max	V	Maximum voltage outputted from O ₂ sensor
F15	O ₂ Min	O ₂ min	V	Minimum voltage outputted from O ₂ sensor
F16	ALPHA	ALPHA	%	AF correction ratio determined in relation to signal outputted from O ₂ sensor
F17	Knock Sensor	RTRD	deg	Ignition timing correction determined in relation to signal-inputted from knock sensor
FA0	ON ↔ OFF Signal	—	—	—
FA1	ON ↔ OFF Signal	—	—	—
FB0	Trouble Code	DIAG	—	Trouble code in U- or D-check mode
FB1	Trouble Code	DIAG	—	Trouble code in Read memory mode
FC0	Clear Memory	—	—	(Used to clear memory)

2. ON ↔ OFF SIGNAL LIST

MODE	LED No.	Contents	Display	LED "ON" requirements
FA0	1	Ignition SW	IG	Ignition switch "ON"
	2	AT/MT discrimination	AT	Vehicle is AT model.
	3	Test Mode	UD	Test mode connector connected
	4	Read Memory	RM	Read memory connector connected
	7	Neutral SW	NT	Neutral switch "ON"
	10	O ₂ Monitor	O ₂	Mixture ratio is rich.
FA1	1	Idle SW	ID	Idle switch "ON"
	2	A/C SW	AC	Air conditioner switch "ON"
	3	A/C Relay	AR	Air conditioner relay "ON"
	4	Radiator Fan	RF	Radiator fan in operation
	6	Fuel Pump Relay	FP	Fuel pump relay in operation
	7	Purge control solenoid valve	CN	Solenoid valve in operation.
	8	Knock Sensor	KS	Engine knocks occur
	10	O ₂ Monitor	O ₂	Mixture ratio is rich.

5. Control Unit I/O Signal



B2-730

Fig. 35

Content	Connector No.	Terminal No.	Signal (V)			Note	
			Ig SW		Engine ON (Idling)		
			OFF	ON (Engine OFF)			
Crank angle sensor	Signal (+)	B127	7	—	0	*	*Sensor output waveform
	Signal (-)	B127	8	—	0	0	—
	Shield	B127	6	—	0	0	—
Cam angle sensor	Signal (+)	B126	6	—	0	*	*Sensor output waveform
	Signal (-)	B126	5	—	0	0	—
	Shield	B126	7	—	0	0	—
Air flow sensor	Power supply	B127	5	—	10 — 13	13 — 14	—
	Signal	B127	12	—	Approx. 0.4	Approx. 1.5	—
	GND	B127	4	—	0	0	—
	Shield	B127	13	—	0	0	—
Throttle sensor	Signal	B126	10	—	Fully closed: 0.5 Fully opened: 4.2	Fully closed: 0.5, Fully opened: 4.2	—
	Power supply	B126	21	—	Approx. 5	Approx. 5	—
	GND	B126	9	—	0	0	—
	Shield	B126	20	—	0	0	—
O ₂ sensor	Signal	B127	1	—	0.1		Rich mixture: 0.7 — 1.0 Lean mixture: 0 — 0.2
	Shield	B127	2	—	0	0	—
Knock sensor	Signal	B126	3	—	Approx. 2.5	Approx. 2.5	—
	Shield	B126	14	—	0	0	—
Water temperature sensor	B127	3	0	0.6 — 4.5	—	—	
Vehicle speed sensor 2	B106	8	—	0 or 3 min.	0 or 3 min.	"3" and "0" are repeatedly displayed when vehicle is driven.	
Idle switch	B126	8	—	ON: 0, OFF: 11	ON: 0.7 OFF: 13	—	
Starter switch	B126	19	—	0	0	Cranking: 10 to 14	
Air conditioner switch	B106	10	—	ON: 10 — 13 OFF: 0	ON: 13 — 14, OFF: 0	—	
Ignition switch	B126	18	0	10 — 13	13 — 14	—	
Neutral switch (MT) or Inhibitor switch (AT)	B126	16	—	[AT] N & P Range: 10 — 13, Other: 0 [MT] N Position: 10 — 13, Other: 0	[AT] N & P Range: 13 — 14, Other: 0 [MT] N Position: 13 — 14 Other: 0	—	
Test mode connector	B127	11	—	10 — 13	13 — 14	When connected: 0	
Read memory connector	B127	10	—	10 — 13	13 — 14	When connected: 0	
AT/MT identification	B106	9	—	[AT] 0 [MT] 10 — 13	[AT] 0 [MT] 13 — 14	—	

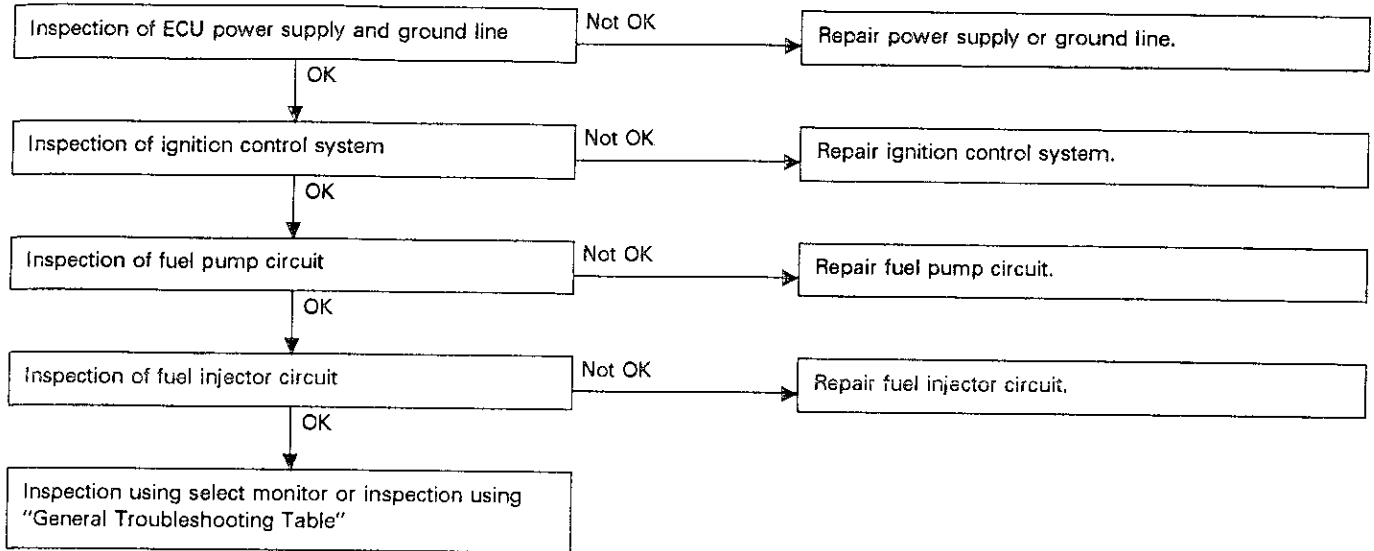
Content	Connector No.	Terminal No.	Signal (V)			Note	
			Ig SW		Engine ON (Idling)		
			OFF	ON (Engine OFF)			
Back-up power supply	B126	12	10 — 13	10 — 13	13 — 14	—	
Control unit	Power	B126	2	0	10 — 13	13 — 14	—
		B126	13	0	10 — 13	13 — 14	—
	GND	B126	1	0	0	0	—
Ignition control	B106	2	—	0	*	* Pulse signal	
Fuel injector	(+)	B106	12	—	0	0	—
	(-)	B106	25	—	0	0	—
	Power	B106	13	Approx. 0.2	10 — 13	13 — 14	—
	GND	B106	26	—	—	—	—
	Shield	B106	22	—	—	—	—
By-pass air control solenoid valve	(+)	B106	11	—	0	*	ECU output waveform
	(-)	B106	24	—	0	0	—
Fuel pump relay control	B106	1	—	ON: Approx. 0.7 OFF: 10 — 13	Approx. 0.8	—	
A/C cut relay control	B106	16	—	ON: 0 OFF: 10 — 13	ON: Approx. 0.5 OFF: 0	—	
Radiator fan control	B106	7	—	ON: 0 OFF: 10 — 13	ON: 0 OFF: 13 — 14	—	
Self-shutoff control	B106	17	—	10 — 13	13 — 14	—	
Trouble code output	B106	18	—	Light ON: 0 Light OFF: 10 — 13	Light ON: 0 Light OFF: 13 — 14	—	
CHECK ENGINE light	B106	19	—	Light ON: 0 Light OFF: 10 — 13	Light ON: 0 Light OFF: 13 — 14	—	
Engine tachometer output	B106	6	—	Approx. 11.5	Approx. 11.5	—	
TI monitor*	B106	20	—	—	—	—	
Purge control solenoid valve	B106	3	—	ON: 0 OFF: 10 — 13	ON: 0 OF: 13 — 14	—	
GND (sensors)	B126	4	—	0	0	—	
GND (ignition system)	B106	14	—	0	0	—	
GND (power supply)	B106	15	—	0	0	—	
GND (control systems)	B126	11	—	0	0	—	
Select Monitor Signal	B127	15	—	Approx. 5	Approx. 5	—	
	B127	16	—	Approx. 4	Approx. 4	—	

*: For manufacture

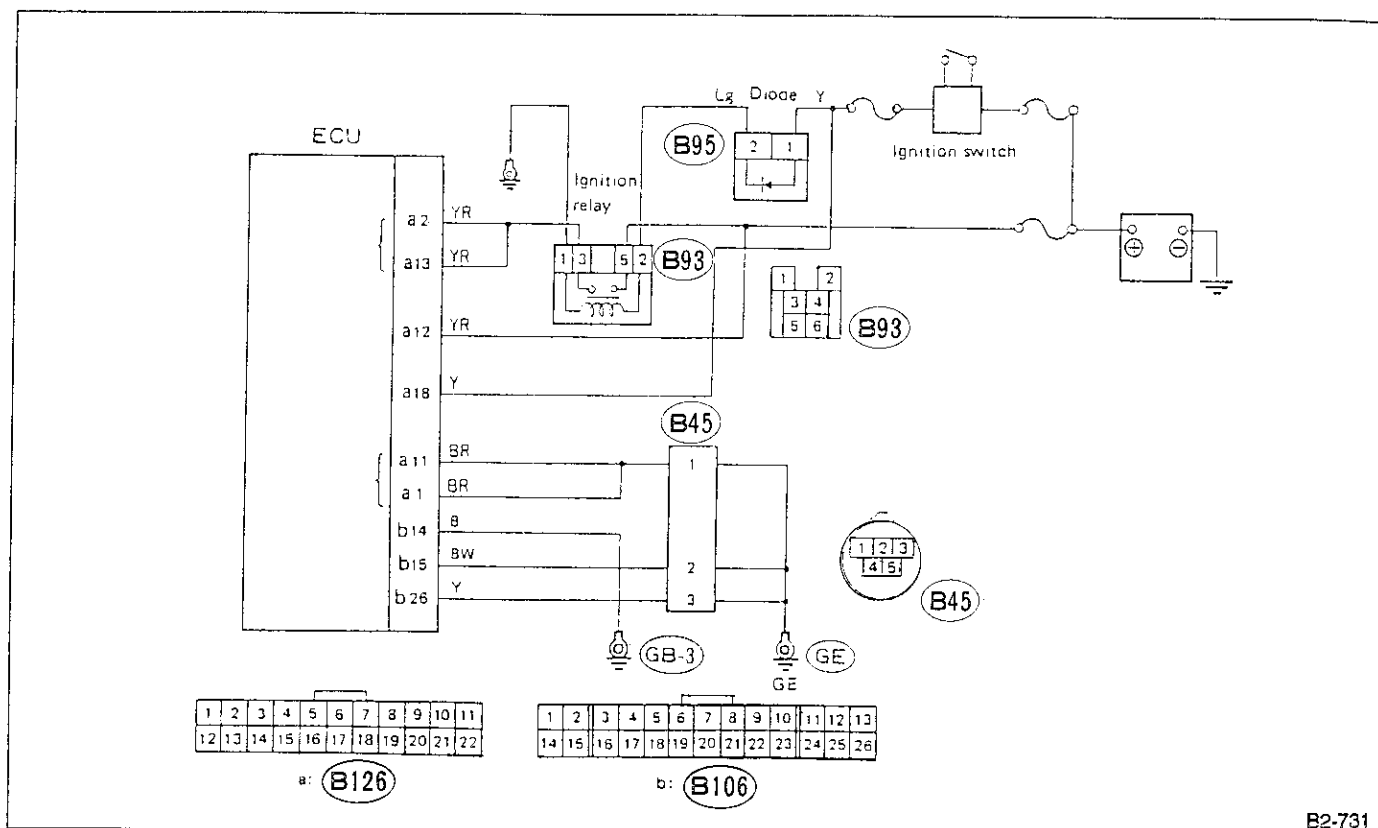
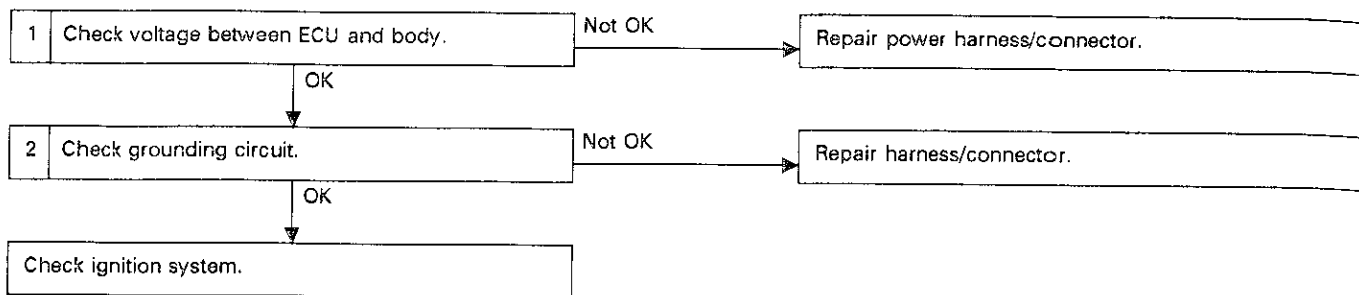
6. Troubleshooting for Engine Starting Failure

A: BASIC TROUBLESHOOTING CHART

When engine cranks but does not start, troubleshoot in accordance with the following chart.



B: CONTROL UNIT POWER SUPPLY AND GROUND LINE



B2-731

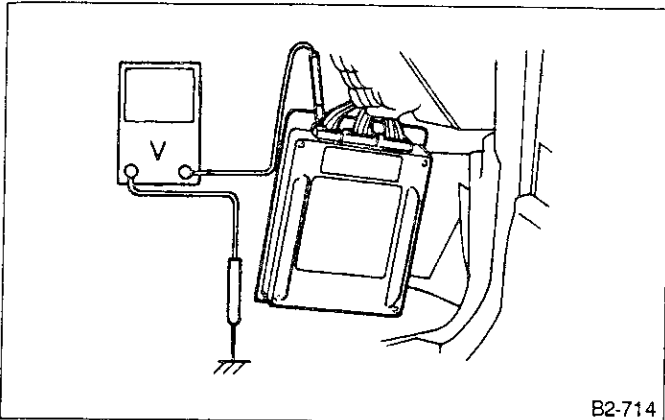
Fig. 36

1. CHECK VOLTAGE BETWEEN ECU AND BODY.

- 1) Turn the ignition switch to "ON."
- 2) Measure voltage between ECU connector terminals and body.

Connector & Terminal/Specified voltage:

- (B126) No. 2 — Body/10 V, min.
- (B126) No. 13 — Body/10 V, min.
- (B126) No. 12 — Body/10 V, min.
- (B126) No. 18 — Body/10 V, min.



B2-714

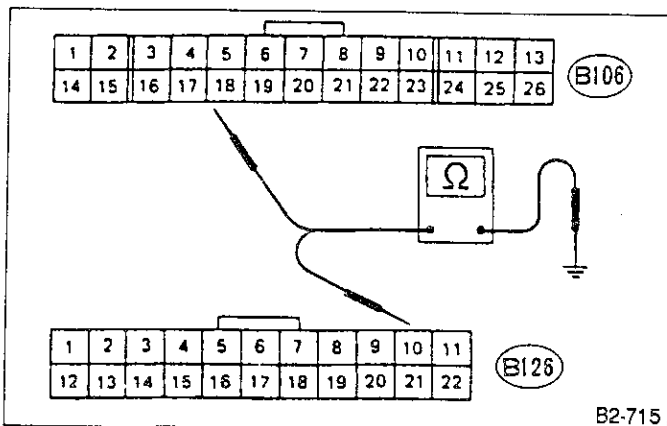
Fig. 37

2. CHECK GROUNDING CIRCUIT.

- 1) Disconnect ECU connector.
- 2) Check continuity between ECU connector terminals and body.

Connector & Terminal/Specified resistance:

- (B126) No. 1 — Body/0 Ω
- (B126) No. 11 — Body/0 Ω
- (B106) No. 14 — Body/0 Ω
- (B106) No. 15 — Body/0 Ω
- (B106) No. 26 — Body/0 Ω



B2-715

Fig. 38

C: IGNITION CONTROL SYSTEM

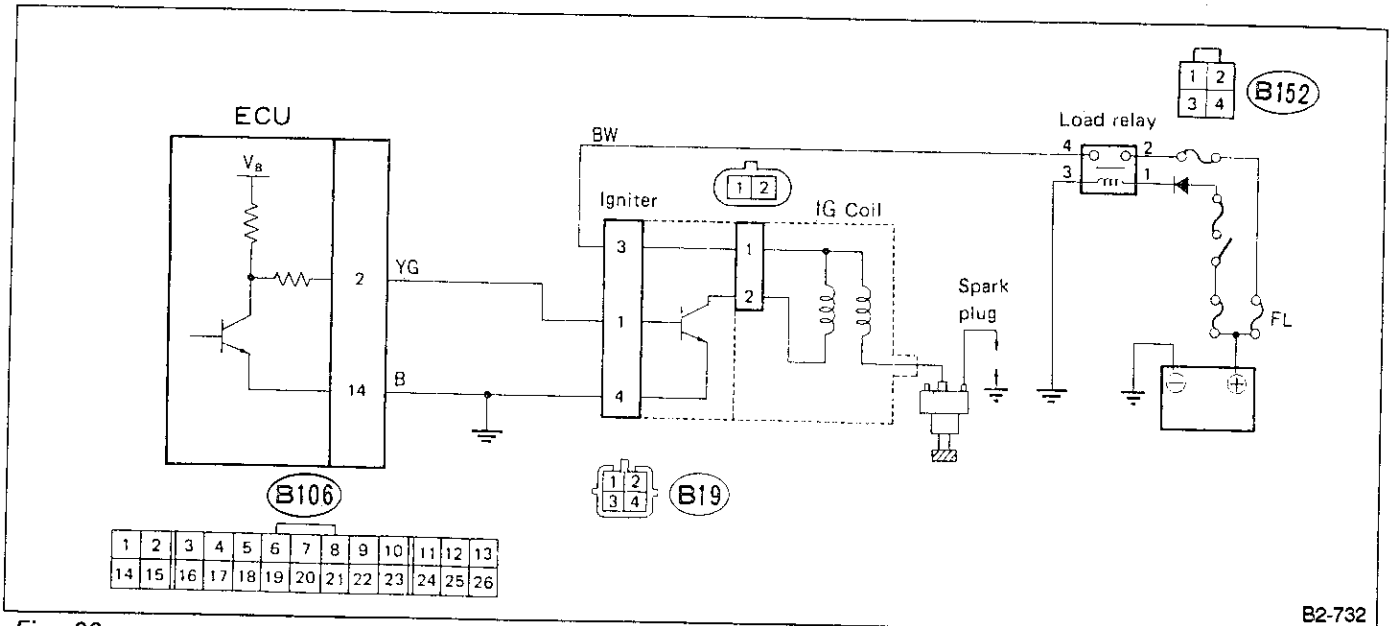
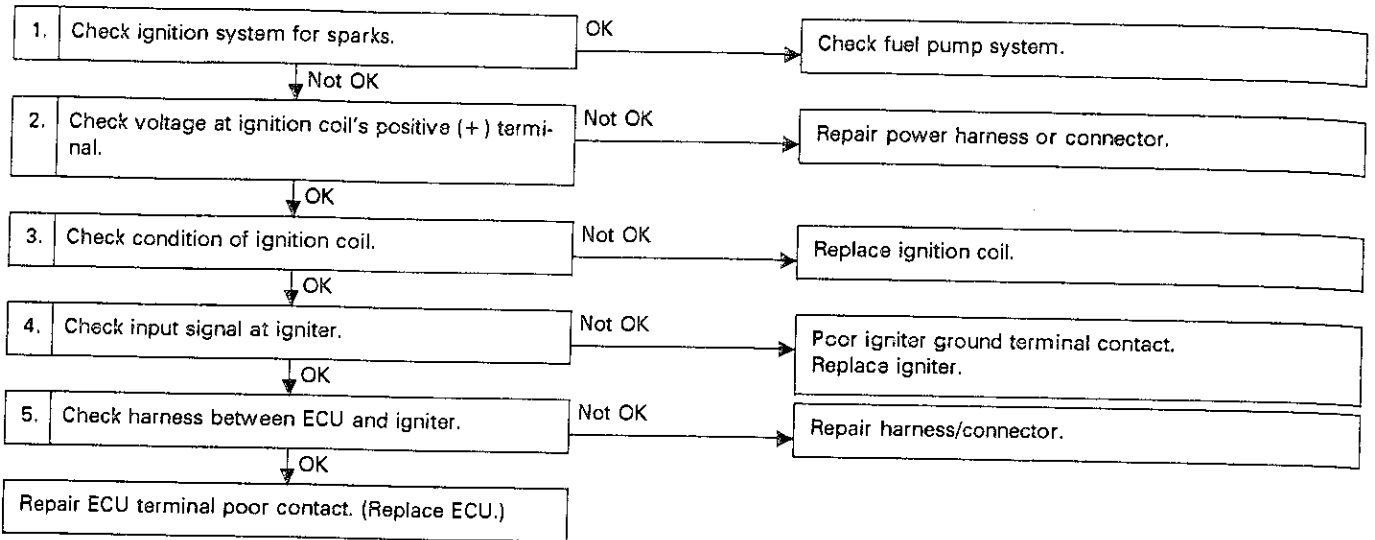


Fig. 39

B2-732

1. CHECK IGNITION SYSTEM FOR SPARKS.

- 1) Remove plug cord cap from each spark plug.
- 2) Install new spark plug on plug cord cap. (Do not remove spark plug from engine.)
- 3) Contact spark plug's thread portion on engine.
- 4) Crank engine to check that spark occurs at each cylinder.

2. CHECK VOLTAGE AT IGNITION COIL'S POSITIVE (+) TERMINAL.

- 1) Disconnect igniter connector.
- 2) Turn ignition switch to "ON".
- 3) Measure voltage between terminal of igniter connector and body.
- 4) Connect igniter connector.
- 5) Disconnect connector from ignition coil.
- 6) Measure voltage between positive terminal of igniter connector and body.

Connector & Terminal/Specified voltage:
 (B19) No. 3 — Body/10 V, min.
 (Ignition coil connector) No. 1 — Body/10 V, min.

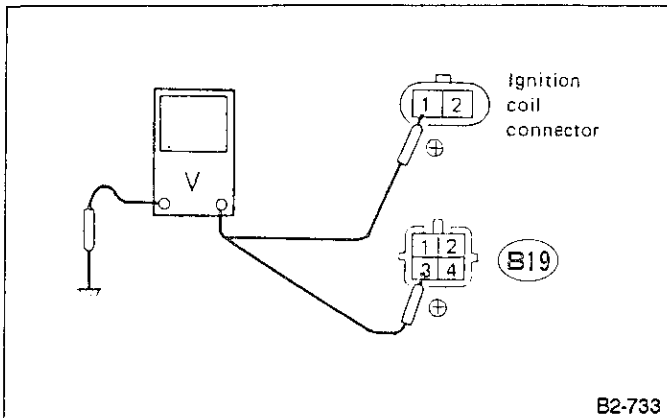


Fig. 40

3. CHECK CONDITION OF IGNITION COIL.

- 1) Disconnect ignition coil connector.
 - 2) Measure resistance of ignition coil's primary and secondary windings.
- Primary side

Specified resistance:
 0.81 — 0.99 Ω

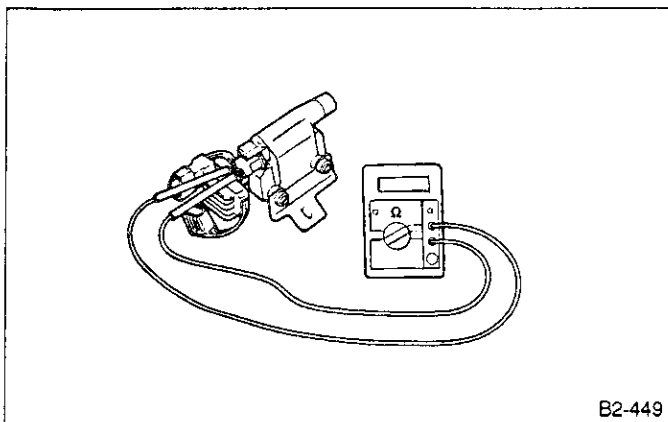


Fig. 41

- Secondary side

Specified resistance:
 8 — 12 kΩ

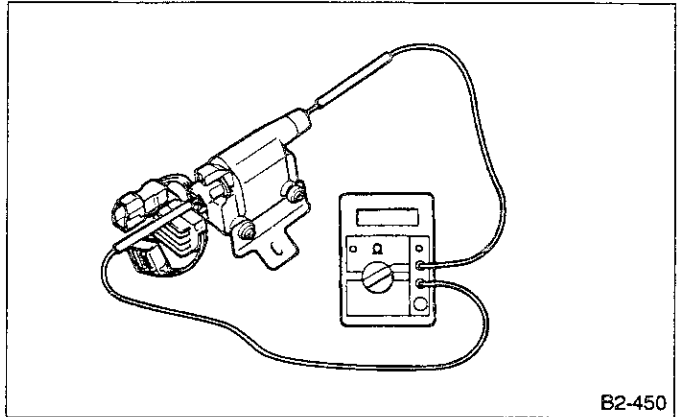


Fig. 42

4. CHECK INPUT SIGNAL AT IGNITER.

Check if voltage varies synchronously with engine revolution when cranking, while monitoring voltage between igniter connector and body.

Connector & Terminal/Specified voltage:
 (B19) No. 1 — Body/0 ↔ *4V

*: As the output voltage is a pulse signal, this inspection data varies between 1 to 4V with the ability of tester.

5. CHECK HARNESS BETWEEN ECU AND IGNITER.

- 1) Disconnect ECU connector and igniter connector.
- 2) Check discontinuity between ECU and igniter connector terminals.

Connector & Terminal/Specified resistance:
 (B106) No. 2 — (B19) No. 1/0 Ω
 (B106) No. 14 — Body/0 Ω
 (B19) No. 4 — Body/0 Ω

- 3) Measure resistance between connector terminals and body to check short-circuit.

Connector & Terminal/Specified resistance:
 (B19) No. 1 — Body/1 MΩ min.

D: FUEL PUMP CIRCUIT

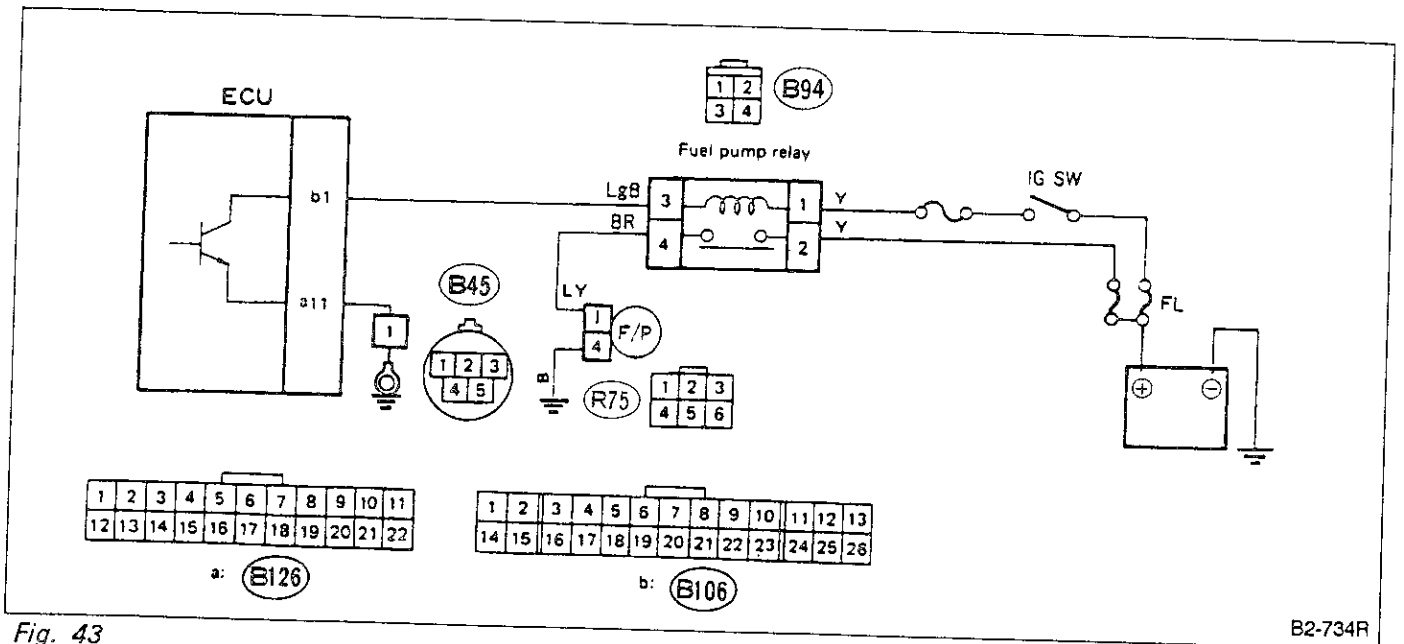
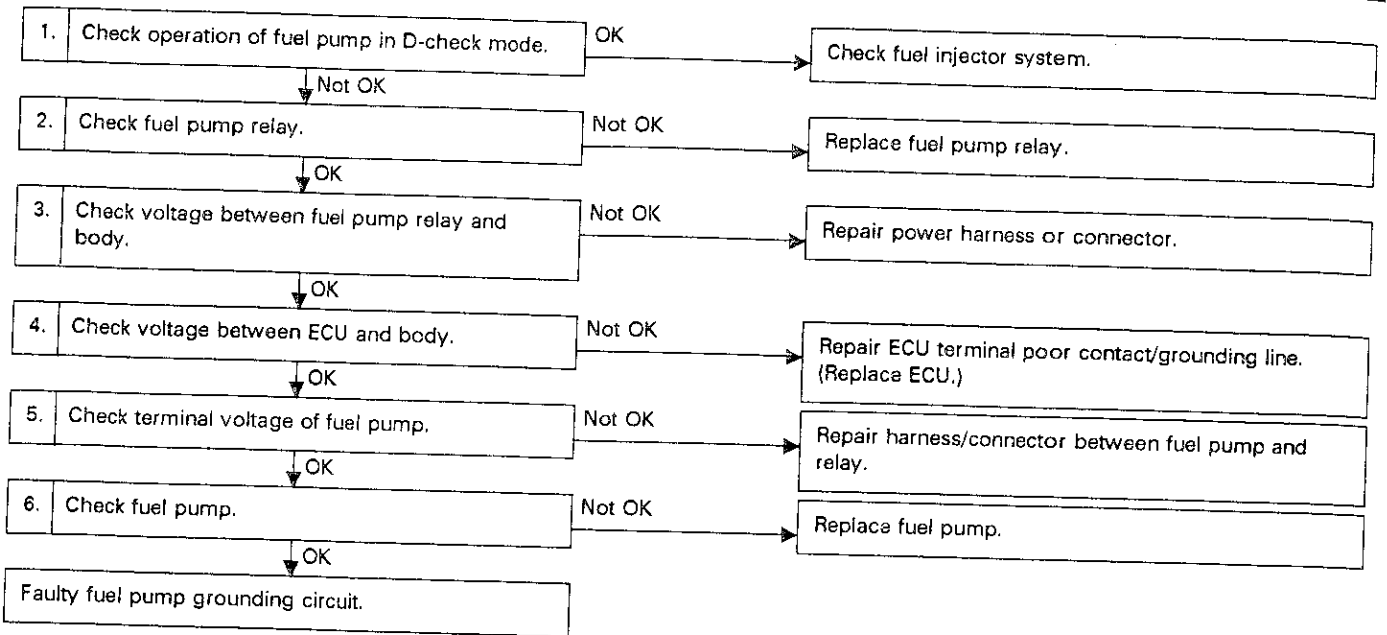


Fig. 43

B2-734R

1. CHECK OPERATION OF FUEL PUMP IN D-CHECK MODE.

- 1) Connect test-mode connector.
- 2) Turn ignition switch to "ON".
- 3) Check fuel pump for proper operation.

2. CHECK FUEL PUMP RELAY.

- 1) Disconnect fuel pump relay connector and remove relay from bracket.
- 2) Measure resistance of relay coil.

Terminal/Specified resistance:
No. 1 — No. 3/70 Ω

- 3) Connect battery (12 volts) to fuel pump relay coil terminals and check continuity between switching terminals. (Relay must issue clicks).

Terminal/Specified resistance:
No. 2 — No. 4/0 Ω
(No. 1: Battery ⊕)
(No. 3: Battery ⊖)

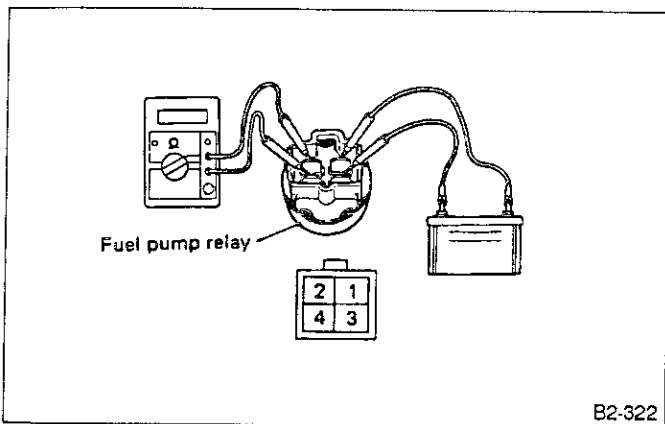


Fig. 44

3. CHECK VOLTAGE BETWEEN FUEL PUMP RELAY AND BODY.

- 1) Turn ignition switch to "ON", and remove fuel pump relay. (Do not disconnect connector.)
- 2) Measure voltage between fuel pump relay connector and body.

Connector & Terminal/Specified voltage:
(B94) No. 1 — Body/10 V, min.

4. CHECK VOLTAGE BETWEEN ECU AND BODY.

- 1) Turn ignition switch to "ON".
- 2) Measure voltage when ignition switch is in "ON". Also measure voltage when cranking the engine.

Connector & Terminal/Specified voltage:
(B106) No. 1 — Body/
10 V, min. (Ignition ON)
0 V (when cranking the engine)

5. CHECK TERMINAL VOLTAGE OF FUEL PUMP.

- 1) Remove access lid of fuel pump located in trunk compartment and remove fuel pump connector.
- 2) Measure voltage between connector and body while cranking the engine.

Connector & Terminal/Specified voltage:
(R75) No. 1 — Body/10 V, min.

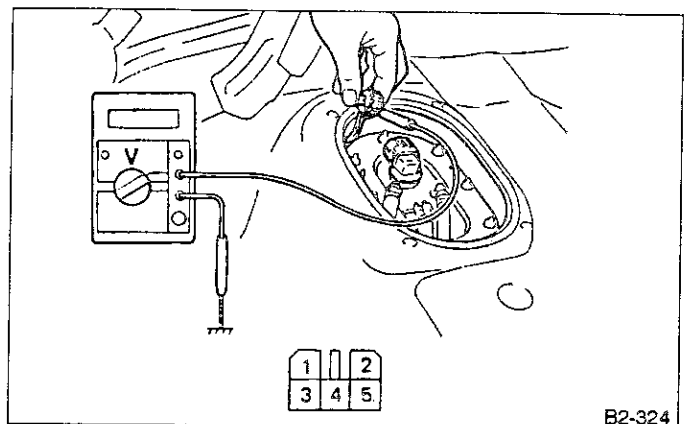


Fig. 45

6. CHECK FUEL PUMP.

- 1) Disconnect fuel pump connector.
- 2) Connect 12-volt battery to proper fuel pump connector terminal and GND terminal to check fuel pump operation.

Terminal:
No. 1 → Battery ⊕
No. 4 → Battery ⊖

E: FUEL INJECTOR CIRCUIT

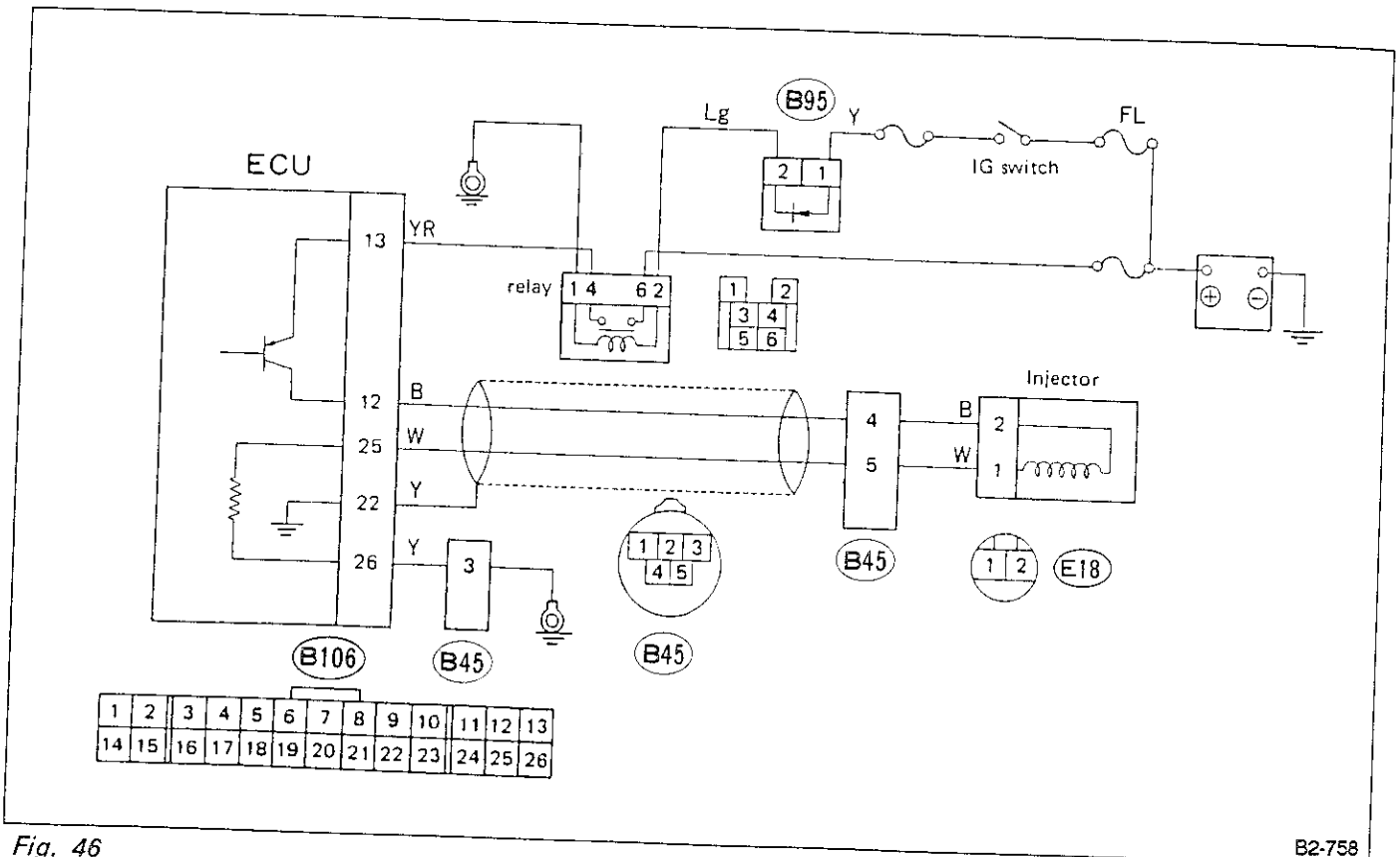
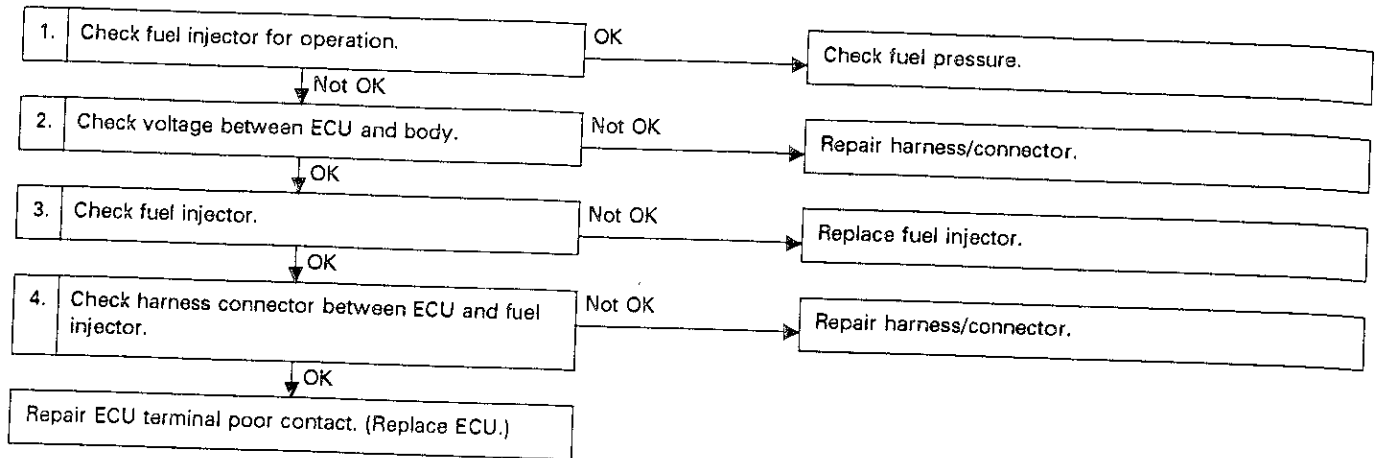


Fig. 46

B2-758

1. CHECK FUEL INJECTOR FOR OPERATION.

Remove air cleaner. While cranking the engine, check that injectors inject fuel properly. Proper fuel injection can be checked by "pulsations" felt on your hand when fuel hose between fuel injector and fuel damper is touched.

2. CHECK VOLTAGE BETWEEN ECU.

- 1) Turn ignition switch "ON".
- 2) Measure voltage between ECU connector terminal and body.

Connector & Terminal/Specified voltage:
(B106) No. 13 — Body/10 V, min.

3. CHECK FUEL INJECTORS.

- 1) Disconnect connector from injector.
- 2) Measure resistance between injector terminals.

Specified resistance:
Approx. 1.5 Ω

4. CHECK HARNESS CONNECTOR BETWEEN ECU AND FUEL INJECTOR.

- 1) Disconnect ECU connector and fuel injector connector.
- 2) Measure resistance between ECU connector and fuel injector connector.

Connector & Terminal/Specified resistance:

(B106) No. 12 — (E18) No. 2/0 Ω

(B106) No. 25 — (E18) No. 1/0 Ω

(B106) No. 12 — Body/1 M Ω min.

(B106) No. 25 — Body/1 M Ω min.

(B106) No. 26 — Body/0 Ω

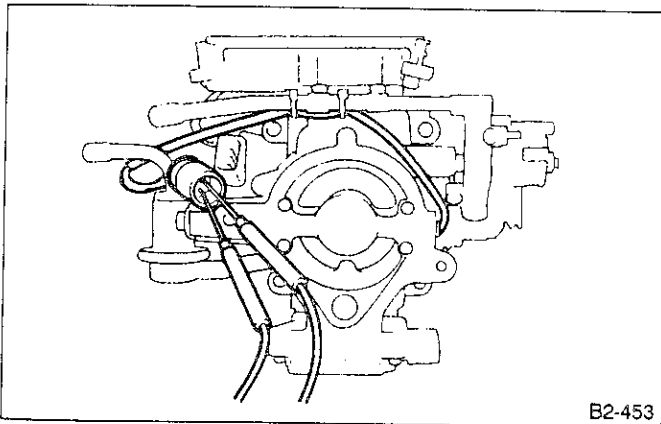


Fig. 47

7. Troubleshooting Chart with Trouble Code

A: TROUBLE CODE (11) —CRANK ANGLE SENSOR—

CONTENT OF DIAGNOSIS:
 No signal entered from crank angle sensor, but signal (corresponding to at least one rotation of crank) entered from cam angle sensor

TROUBLE SYMPTOM:

- Engine stall
- Restarting impossible

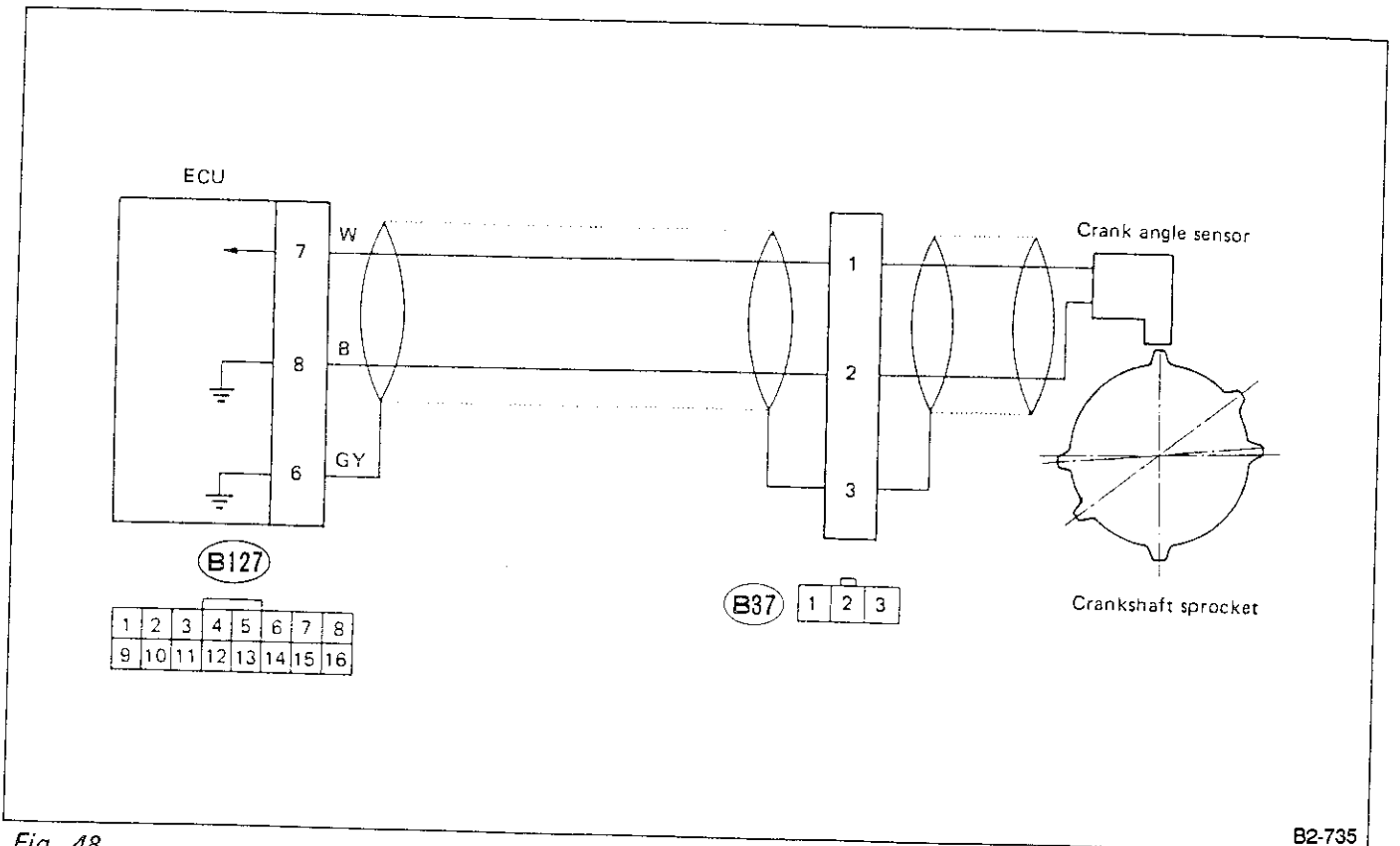
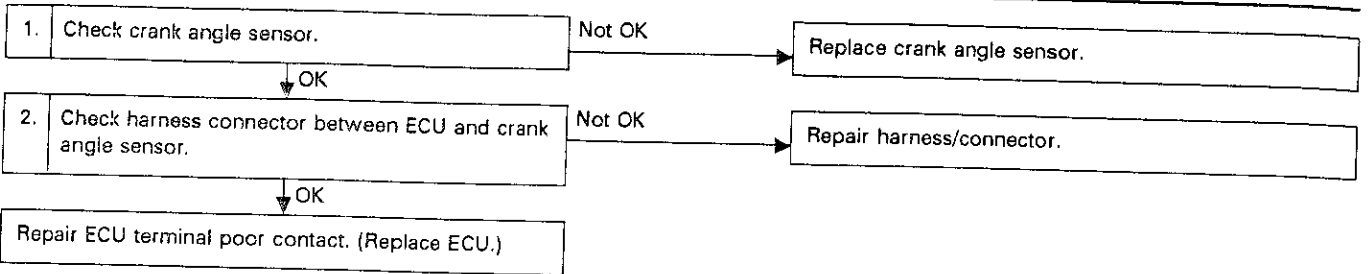


Fig. 48

B2-735

1. CHECK CRANK ANGLE SENSOR.

- 1) Disconnect crank angle sensor connector.
- 2) Check if voltage varies synchronously with engine revolutions when cranking, while monitoring voltage between crank angle sensor connector terminals (AC 0.1 V, min.).

Terminal:

No. 1 — No. 2

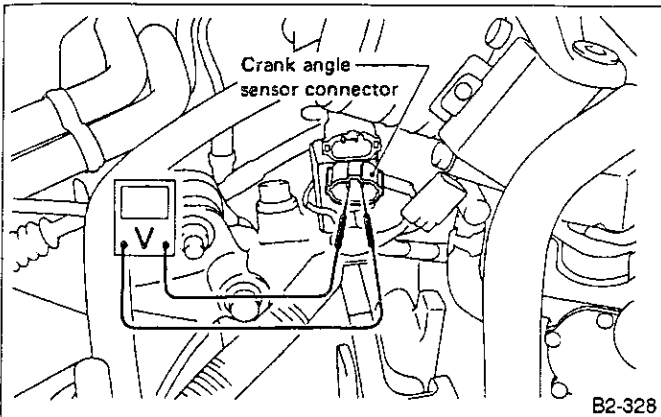


Fig. 49

2. CHECK HARNESS CONNECTOR BETWEEN ECU AND CRANK ANGLE SENSOR.

- 1) Disconnect connectors from ECU and crank angle sensor.
- 2) Measure resistance between ECU connector and crank angle sensor connector.

Connector & Terminal/Specified resistance:

- (B127) No. 7 — (B37) No. 1/0 Ω
- (B127) No. 8 — (B37) No. 2/0 Ω
- (B127) No. 6 — (B37) No. 3/0 Ω

- 3) Measure resistance between crank angle sensor connector and body.

Connector & Terminal/Specified resistance:

- (B37) No. 1 — Body/1 MΩ min.
- (B37) No. 2 — Body/1 MΩ min.

- 4) Connect ECU connector and measure resistance between crank angle sensor sealed terminal and body.

Connector & Terminal/Specified resistance:

- (B37) No. 3 — Body/0 Ω

- 5) Disconnect cam angle sensor connector and measure resistance between sealed terminal and body.

Connector & Terminal/Specified resistance:

- (B39) No. 3 — Body/0 Ω

• SELECT MONITOR FUNCTION MODE

Mode: F04

Condition: Engine at idle

Specified Data: EREV F04
 850 ± 100 rpm (MT)
 800 ± 100 rpm (AT)

B: TROUBLE CODE (12) — STARTER SWITCH —

CONTENT OF DIAGNOSIS:
Abnormal signal emitted from ignition starter switch

TROUBLE SYMPTOM:
Failure of engine to start

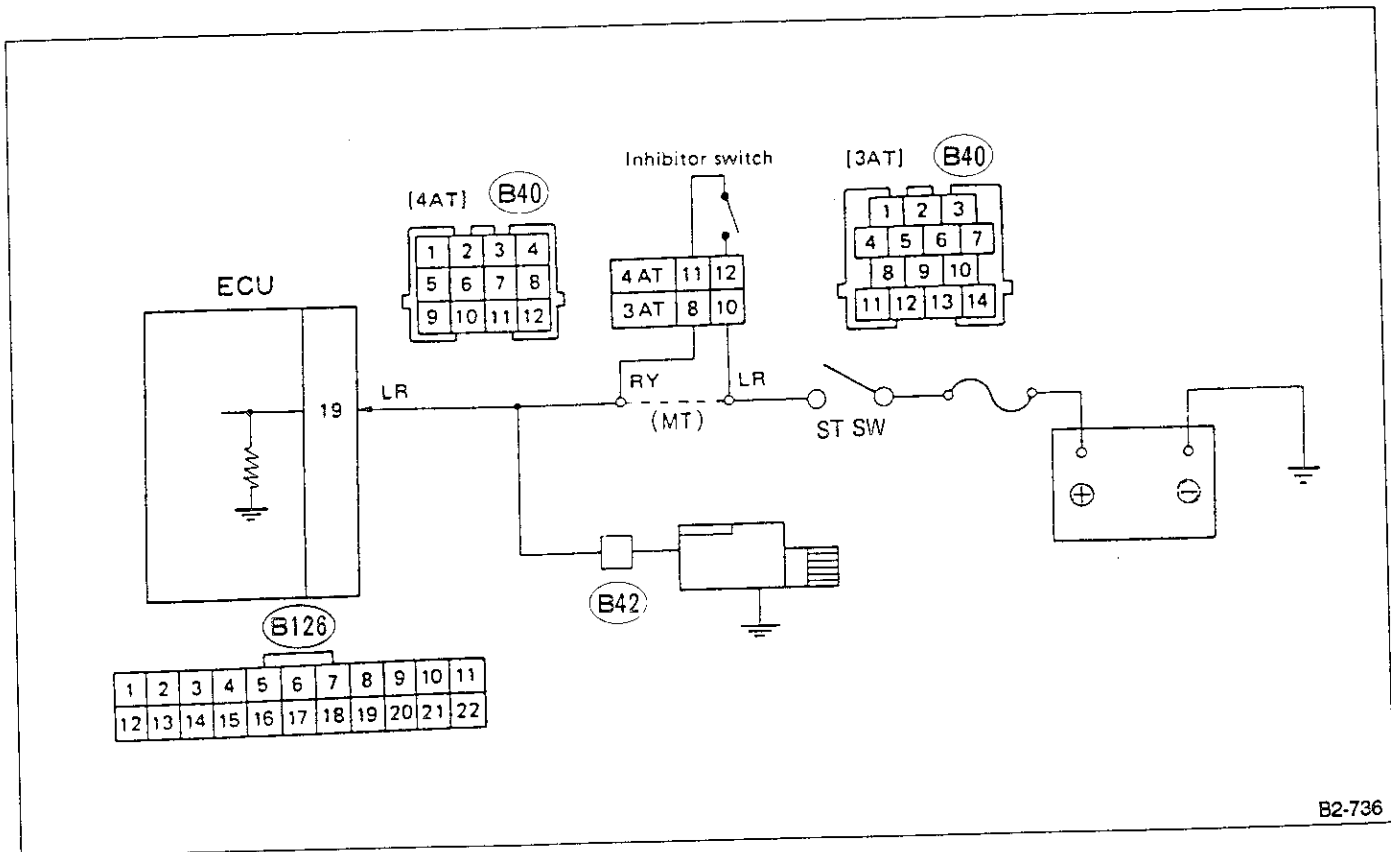
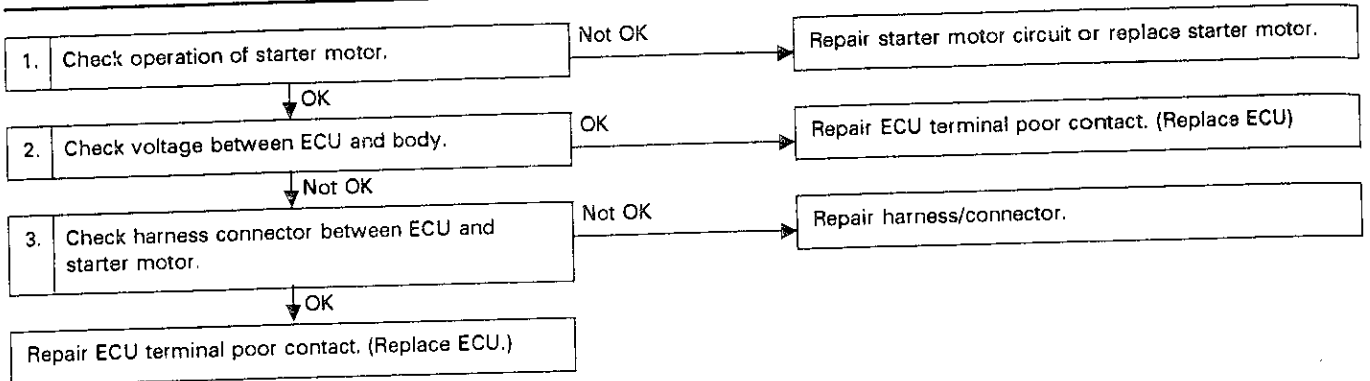


Fig. 50

1. CHECK OPERATION OF STARTER MOTOR.

Turn ignition switch to 'ST' to ensure that starter motor functions.

2. MEASURE VOLTAGE BETWEEN ECU AND BODY.

Measure voltage between ECU connector terminal and body while cranking the engine.

Connector & Terminal/Specified voltage:
(B126) No. 19 — Body/10 V, min.

3. CHECK HARNESS CONNECTOR BETWEEN ECU AND STARTER MOTOR.

- 1) Disconnect connectors from ECU and starter motor.
- 2) Measure resistance between ECU connector and starter motor connector.

Connector & Terminal/Specified resistance:
(B126) No. 19 — (B42) No. 1/0 Ω

- 3) Measure resistance between starter motor connector and body.

Connector & Terminal/Specified resistance:
(B42) No. 1 — Body/1 M Ω min.

C: TROUBLE CODE (13) — CAM ANGLE SENSOR —

CONTENT OF DIAGNOSIS:

No signal entered from cam angle sensor, but signal (corresponding to at least two rotations of cam) entered from crank angle sensor

TROUBLE SYMPTOM:

- Engine stall
- Failure of engine to start

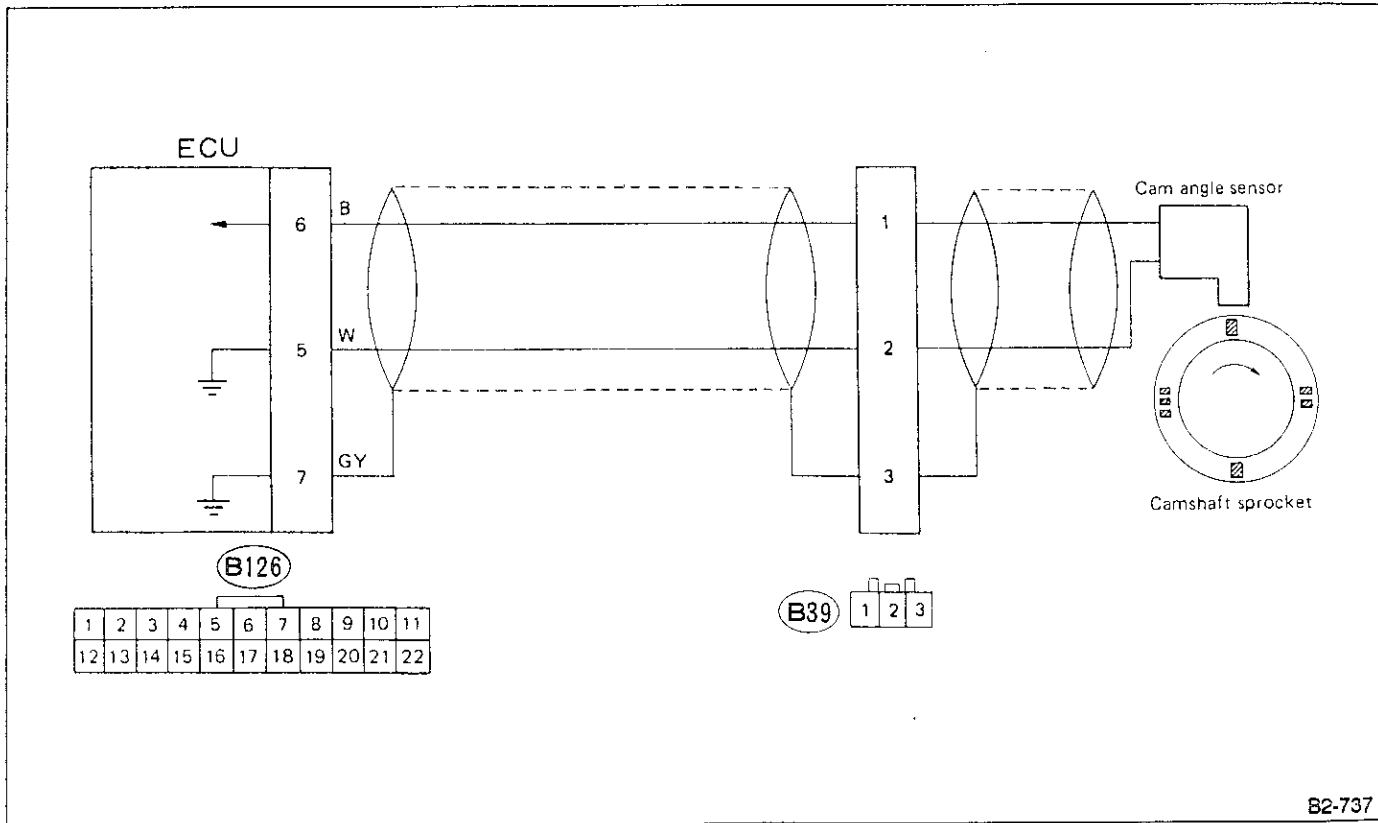
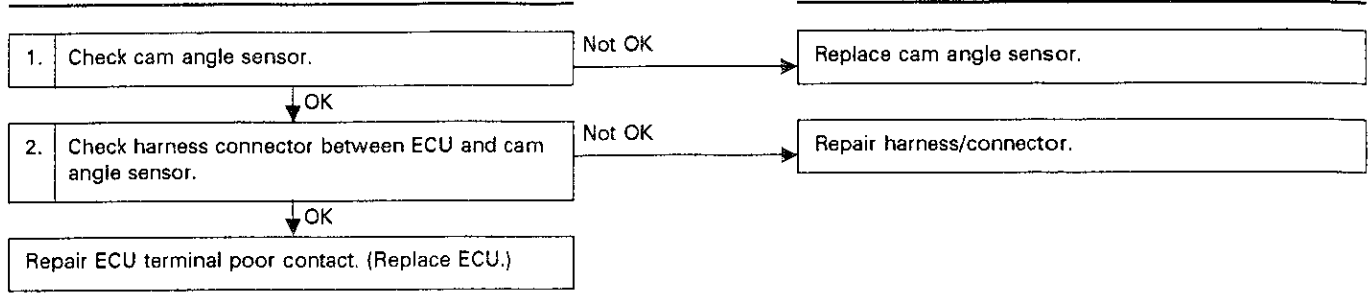


Fig. 51

1. CHECK CAM ANGLE SENSOR.

- 1) Disconnect cam angle sensor connector.
- 2) Check if voltage varies synchronously with engine revolutions when cranking, while monitoring voltage between cam angle sensor connector terminals (AC 0.1 V, min.).

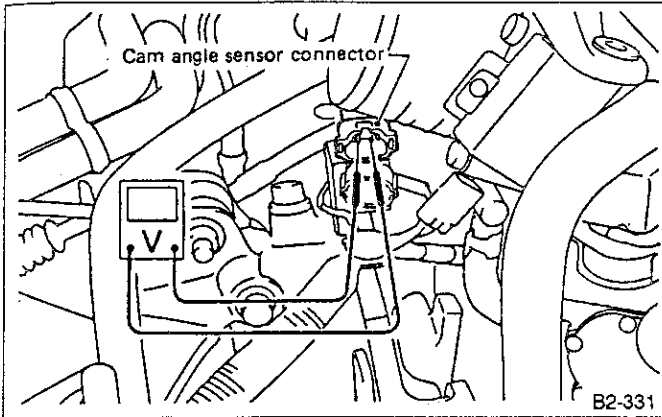


Fig. 52

2. CHECK HARNESS CONNECTOR BETWEEN ECU AND CAM ANGLE SENSOR.

- 1) Disconnect connectors from ECU and cam angle sensor.
- 2) Measure resistance between ECU connector and cam angle sensor connector.

Connector & Terminal/Specified resistance:
 (B126) No. 6 — (B39) No. 1/0 Ω
 (B126) No. 5 — (B39) No. 2/0 Ω
 (B126) No. 7 — (B39) No. 3/0 Ω

- 3) Measure resistance between cam angle sensor connector and body.

Connector & Terminal/Specified resistance:
 (B39) No. 1 — Body/1 MΩ min.
 (B39) No. 2 — Body/1 MΩ min.

- 4) Connect ECU connector and measure resistance between cam angle sensor sealed terminal and body.

Connector & Terminal/Specified resistance:
 (B39) No. 3 — Body/0 Ω

- 5) Disconnect crank angle sensor connector and measure resistance between sealed terminal and body.

Connector & Terminal/Specified resistance:
 (B37) No. 3 — Body/0 Ω

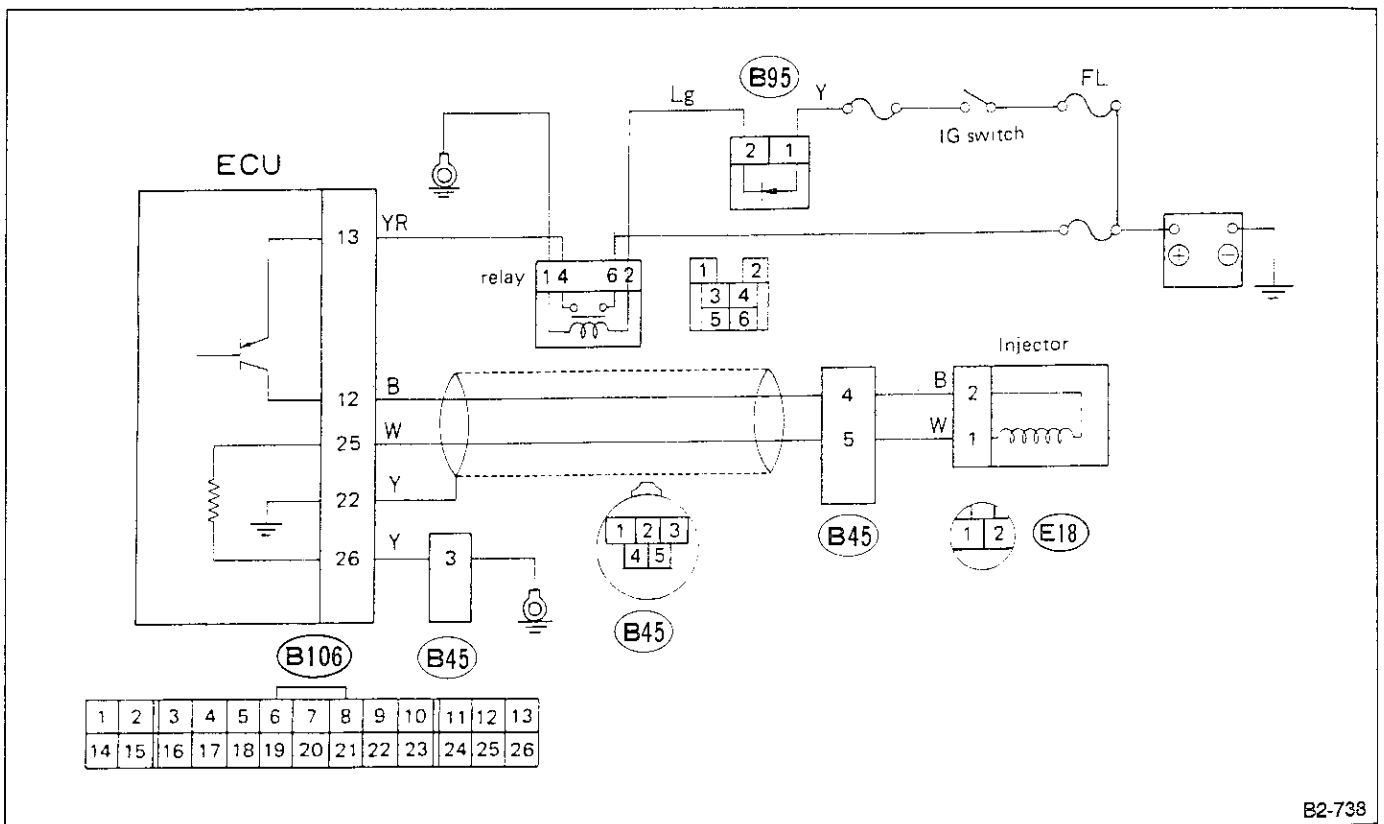
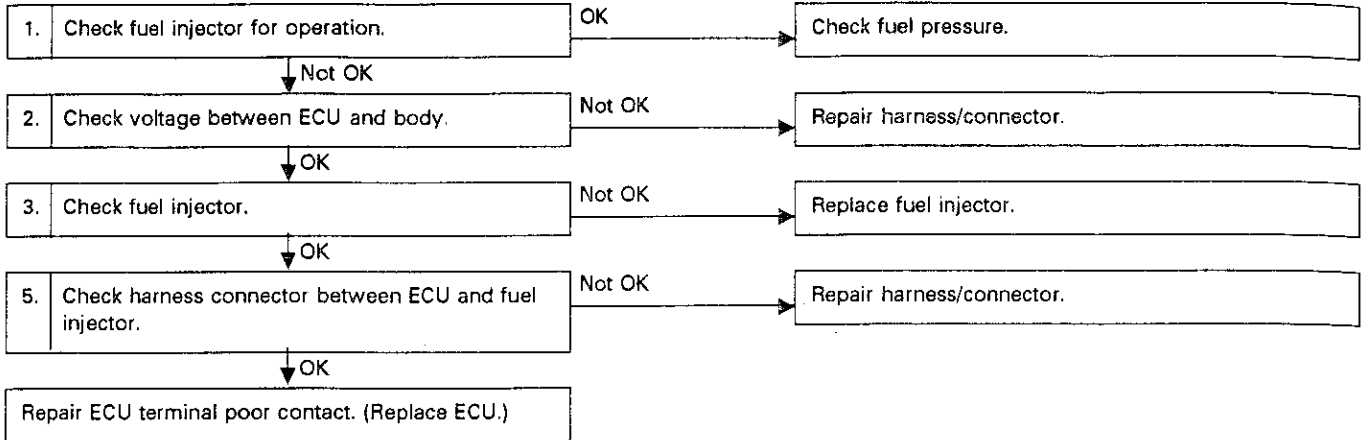
• **SELECT MONITOR FUNCTION MODE**

Mode: F04
Condition: Engine at idle
Specified Data: EREV F04
 850 ± 100 rpm (MT)
 800 ± 100 rpm (AT)

D: TROUBLE CODE (14) — FUEL INJECTOR —

CONTENT OF DIAGNOSIS:
Fuel injector inoperative

TROUBLE SYMPTOM:
 • Engine stall
 • Erroneous idling
 • Rough driving



B2-738

Fig. 53

1. CHECK FUEL INJECTOR FOR OPERATION.

Remove air cleaner. While cranking the engine, check that injectors inject fuel properly.

Proper fuel injection can be checked by "pulsations" felt on your hand when fuel hose between fuel injector and fuel damper is touched.

2. CHECK VOLTAGE BETWEEN ECU.

- 1) Turn ignition switch "ON".
- 2) Measure voltage between ECU connector terminal and body.

Connector & Terminal/Specified voltage:
(B106) No. 13 — Body/10 V, min.

3. CHECK FUEL INJECTORS.

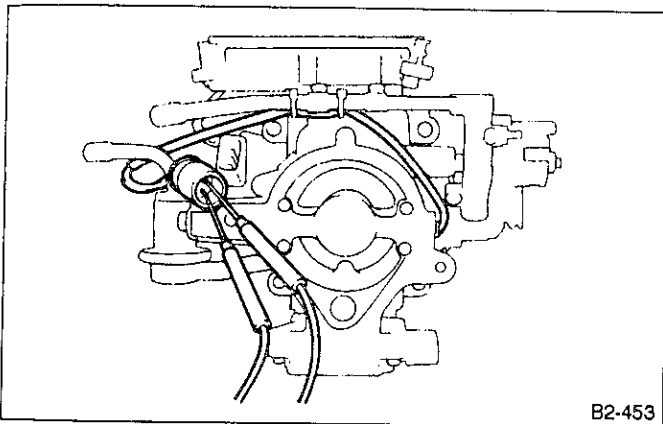
- 1) Disconnect connector from injector.
- 2) Measure resistance between injector terminals.

Specified resistance:
Approx. 1.5 Ω

4. CHECK HARNESS CONNECTOR BETWEEN ECU AND FUEL INJECTOR.

- 1) Disconnect ECU connector and fuel injector connector.
- 2) Measure resistance between ECU connector and fuel injector connector.

Connector & Terminal/Specified resistance:
(B106) No. 12 — (E18) No. 2/0 Ω
(B106) No. 25 — (E18) No. 1/0 Ω
(B106) No. 12 — Body/1 M Ω min.
(B106) No. 25 — Body/1 M Ω min.
(B106) No. 26 — Body/0 Ω



B2-453

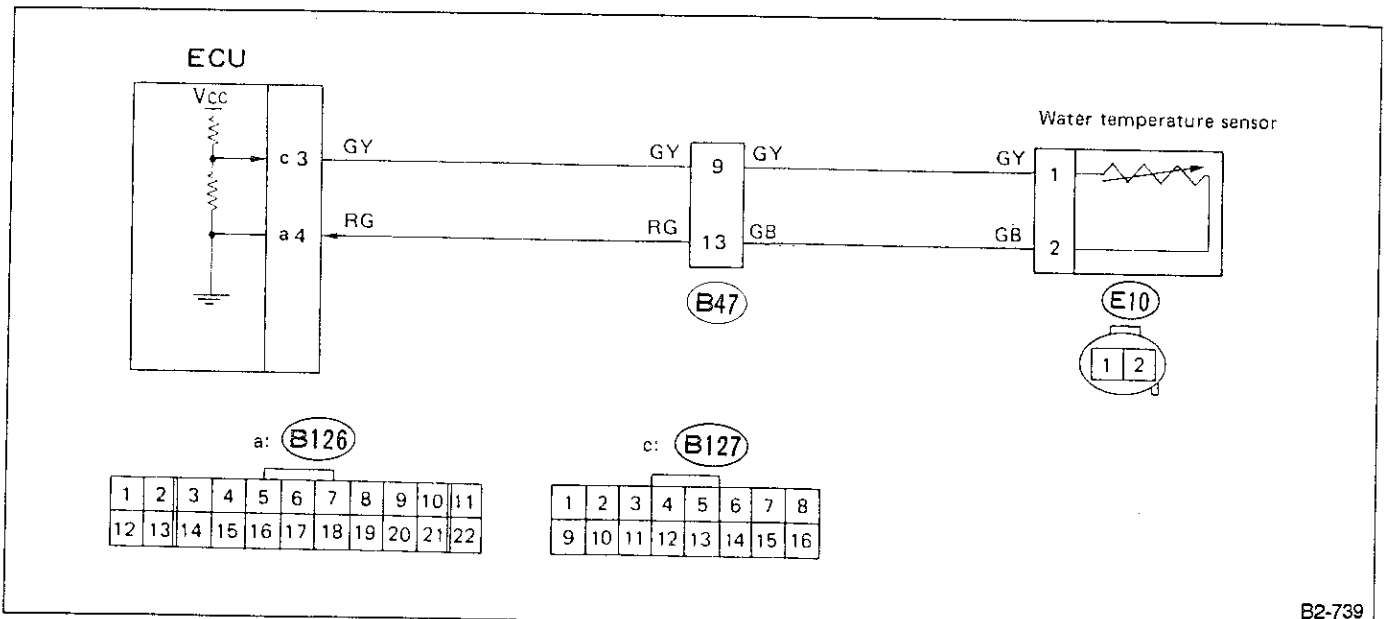
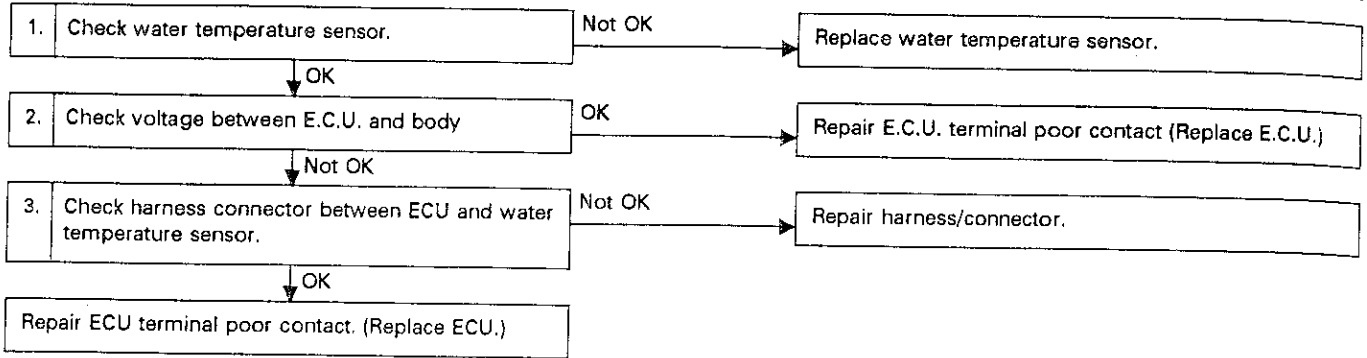
Fig. 54

E: TROUBLE CODE (21) — WATER TEMPERATURE SENSOR —

CONTENT OF DIAGNOSIS:
Abnormal signal emitted from water temperature sensor

TROUBLE SYMPTOM:

- Hard to start
- Erroneous idling
- Poor driving performance



B2-739

Fig. 55

1. CHECK WATER TEMPERATURE SENSOR.

- 1) Disconnect connector from water temperature sensor.
- 2) Measure resistance between water temperature sensor terminals.

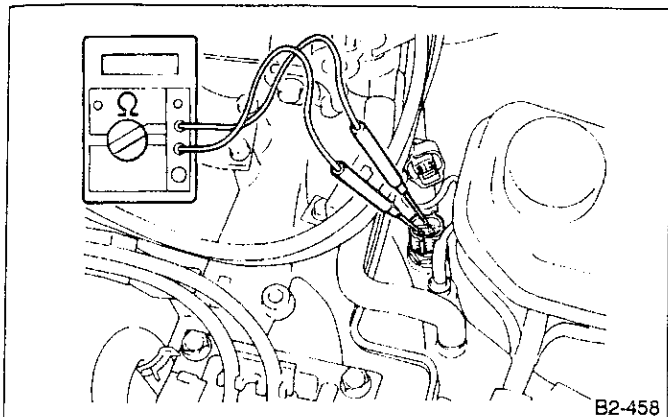


Fig. 56

Specified resistance:

- 2.0 — 3.0 k Ω [20°C (68°F)]
- 0.3 — 0.4 k Ω [80°C (176°F)]

2. CHECK VOLTAGE BETWEEN ECU AND BODY.

- 1) Connect water temperature sensor connector.
- 2) Turn ignition switch to "ON".
- 3) Measure voltage between ECU connector terminal and body.

Connector & Terminal/Specified voltage:

- (B127) No. 3 — Body/0.6 — 4.5 V

3. CHECK HARNESS CONNECTOR BETWEEN ECU AND WATER TEMPERATURE SENSOR.

- 1) Disconnect ECU connector and water temperature sensor connector.
- 2) Measure resistance between ECU connector and water temperature connector.

Connector & Terminal/Specified resistance:

- (B127) No. 3 — (E10) No. 1/0 Ω
- (B126) No. 4 — (E10) No. 2/0 Ω

- 3) Measure resistance between water temperature sensor connector and body.

Connector & Terminal/Specified resistance:

- (E10) No. 1 — Body/1 M Ω min.
- (E10) No. 2 — Body/1 M Ω min.

• SELECT MONITOR FUNCTION MODE

Mode: F06

Condition:

After warming up engine, engine at idle and radiator fan OFF.

Specified Data: TW F06
80 — 95 deg C

F05 = Water temperature signal (TW): To be indicated in "deg F"

F: TROUBLE CODE (22) — KNOCK SENSOR —

CONTENT OF DIAGNOSIS:
Abnormal voltage produced in knock sensor.

TROUBLE SYMPTOM:
Poor driving performance

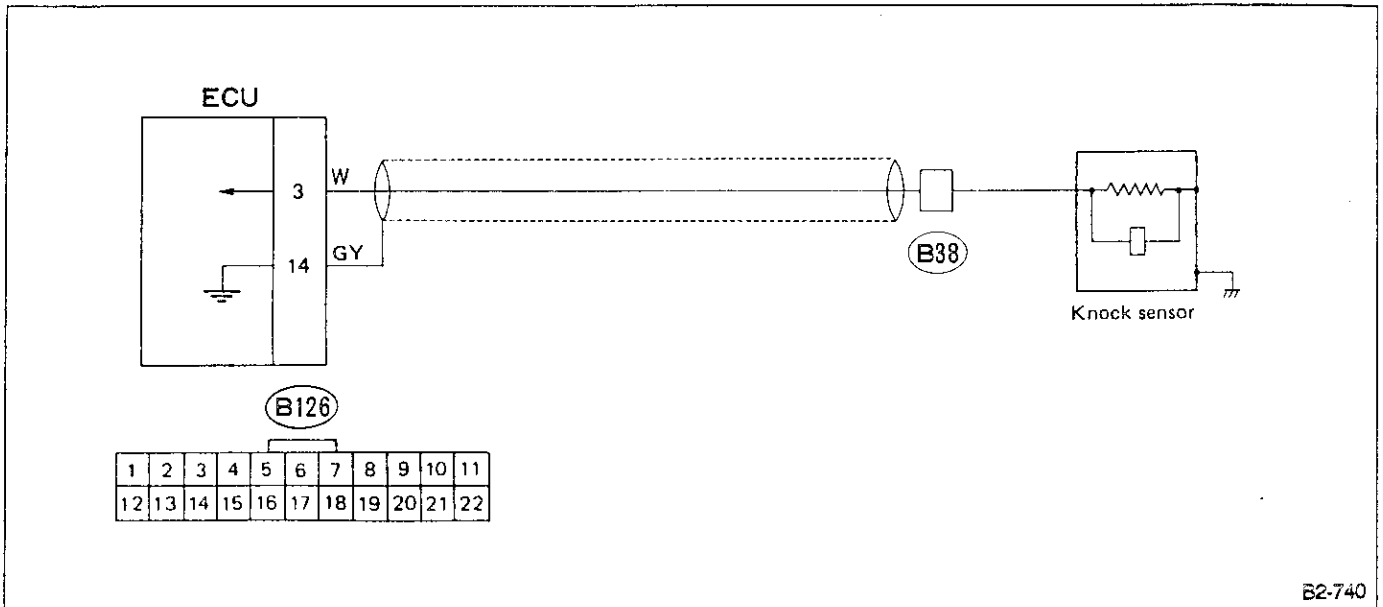
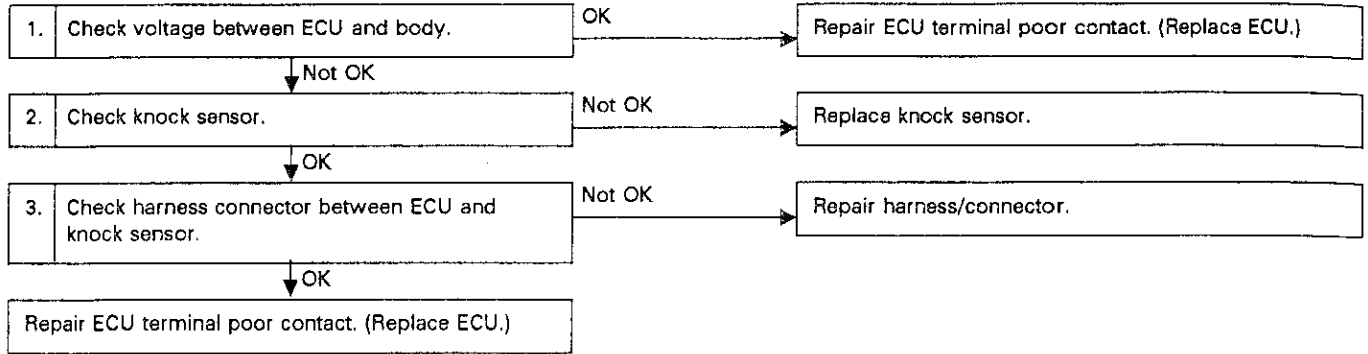


Fig. 57

B2-740

1. CHECK VOLTAGE BETWEEN ECU AND BODY.

- 1) Turn ignition switch to "ON".
- 2) Measure voltage between ECU connector terminal and body.

Connector & Terminal/Specified voltage:
(B126) No. 3 — Body/Approx. 2.5 V

2. CHECK KNOCK SENSOR.

- 1) Disconnect connector from knock sensor.
- 2) Measure resistance between knock sensor terminals and body.

Specified resistance:
Approx. 560 k Ω

3. CHECK HARNESS CONNECTOR BETWEEN ECU AND KNOCK SENSOR.

- 1) Disconnect connectors from ECU and knock sensor.
- 2) Measure resistance between ECU and knock sensor connectors.

Connector & Terminal/Specified resistance:
(B126) No. 3 — (B38) No. 1/0 Ω

- 3) Measure resistance between knock sensor connector and body.

Connector & Terminal/Specified resistance:
(B38) No. 1 — Body/1 M Ω min.

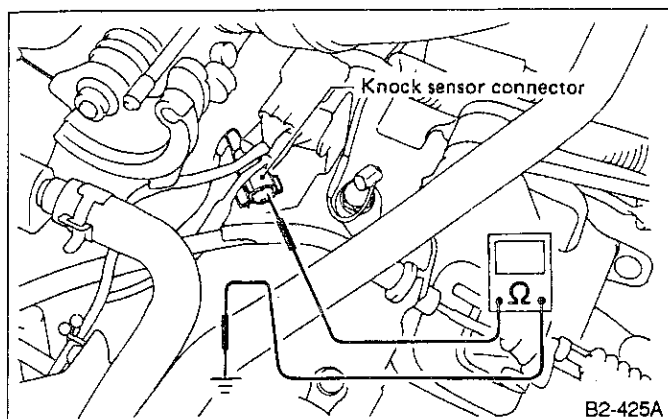


Fig. 58

G: TROUBLE CODE (23) — AIR FLOW SENSOR —

CONTENT OF DIAGNOSIS:
Abnormal voltage input entered from air flow sensor

TROUBLE SYMPTOM:
 • Erroneous idling
 • Engine stall
 • Poor driving performance

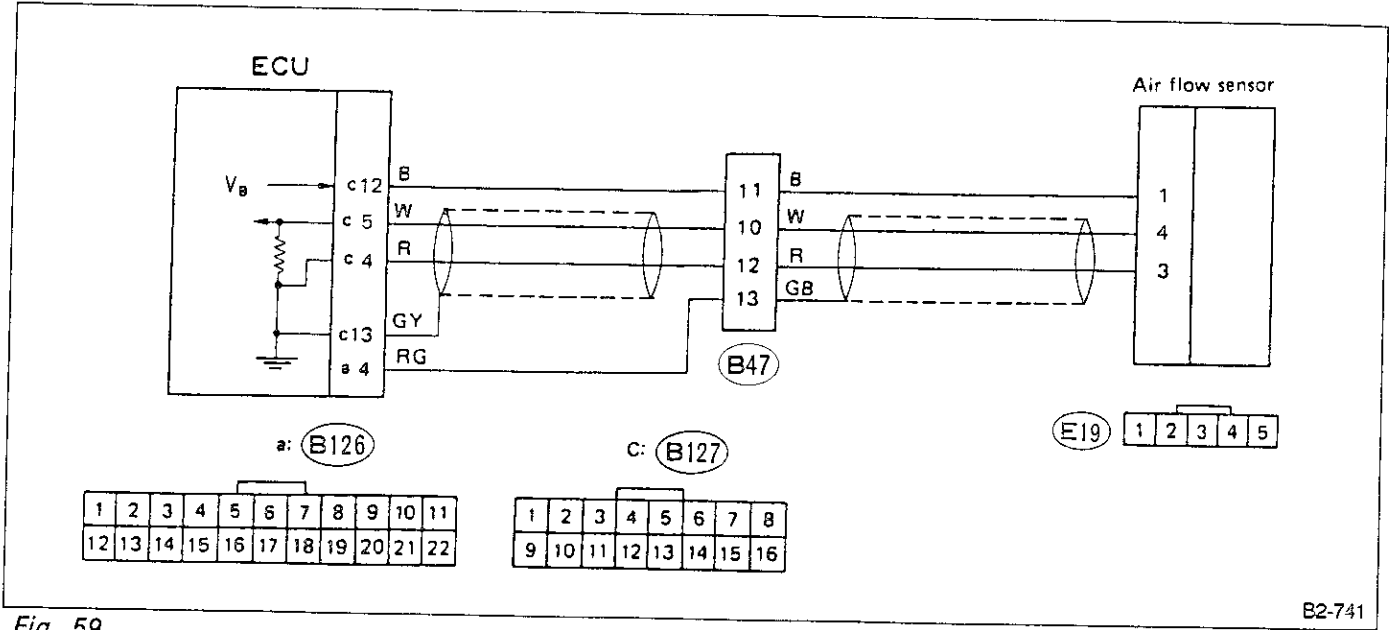
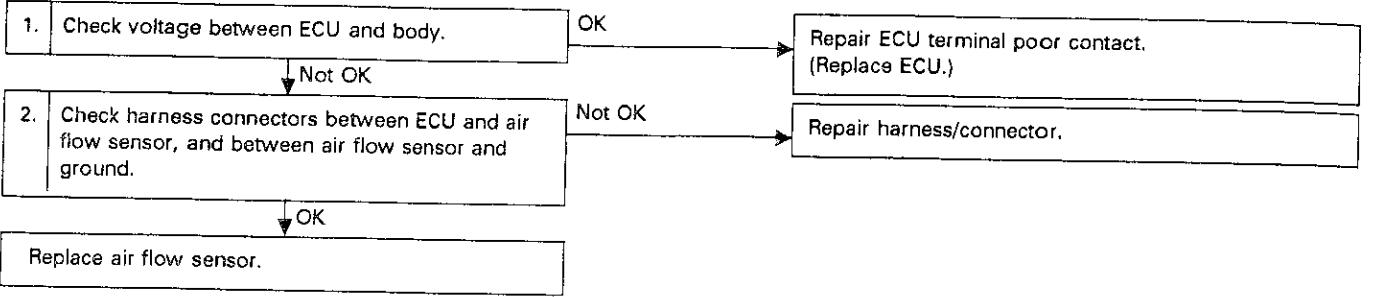


Fig. 59

B2-741

1. CHECK VOLTAGE BETWEEN ECU AND BODY.

- 1) Turn ignition switch to "ON".
- 2) Measure voltage between ECU connector terminal and body.

Connector & Terminal/Specified voltage:

- (B127) No. 12 — Body/
10 — 13 V (Engine OFF)
13 — 14 V (Engine at idle)
- (B127) No. 5 — Body/
Approx. 0.4 V (Engine OFF)
Approx. 1.5 V (Engine at idle)
- (B127) No. 4 — Body/
0 V (Engine OFF)
0 V (Engine at idle)

2. CHECK HARNESS CONNECTOR BETWEEN ECU AND AIR FLOW SENSOR.

- 1) Disconnect ECU and air flow sensor connectors.
- 2) Measure resistance between ECU and air flow sensor connectors.

Connector & Terminal/Specified resistance:

- (B127) No. 12 — (E19) No. 1/0 Ω
- (B127) No. 5 — (E19) No. 4/0 Ω
- (B127) No. 4 — (E19) No. 3/0 Ω

3. Measure resistance between air flow sensor connector and body.

Connector & Terminal/Specified resistance:

- (E19) No. 1 — Body/1 MΩ min.
- (E19) No. 4 — Body/1 MΩ min.
- (E19) No. 3 — Body/1 MΩ min.

• SELECT MONITOR FUNCTION MODE

Mode: F08

Condition: Engine at idle

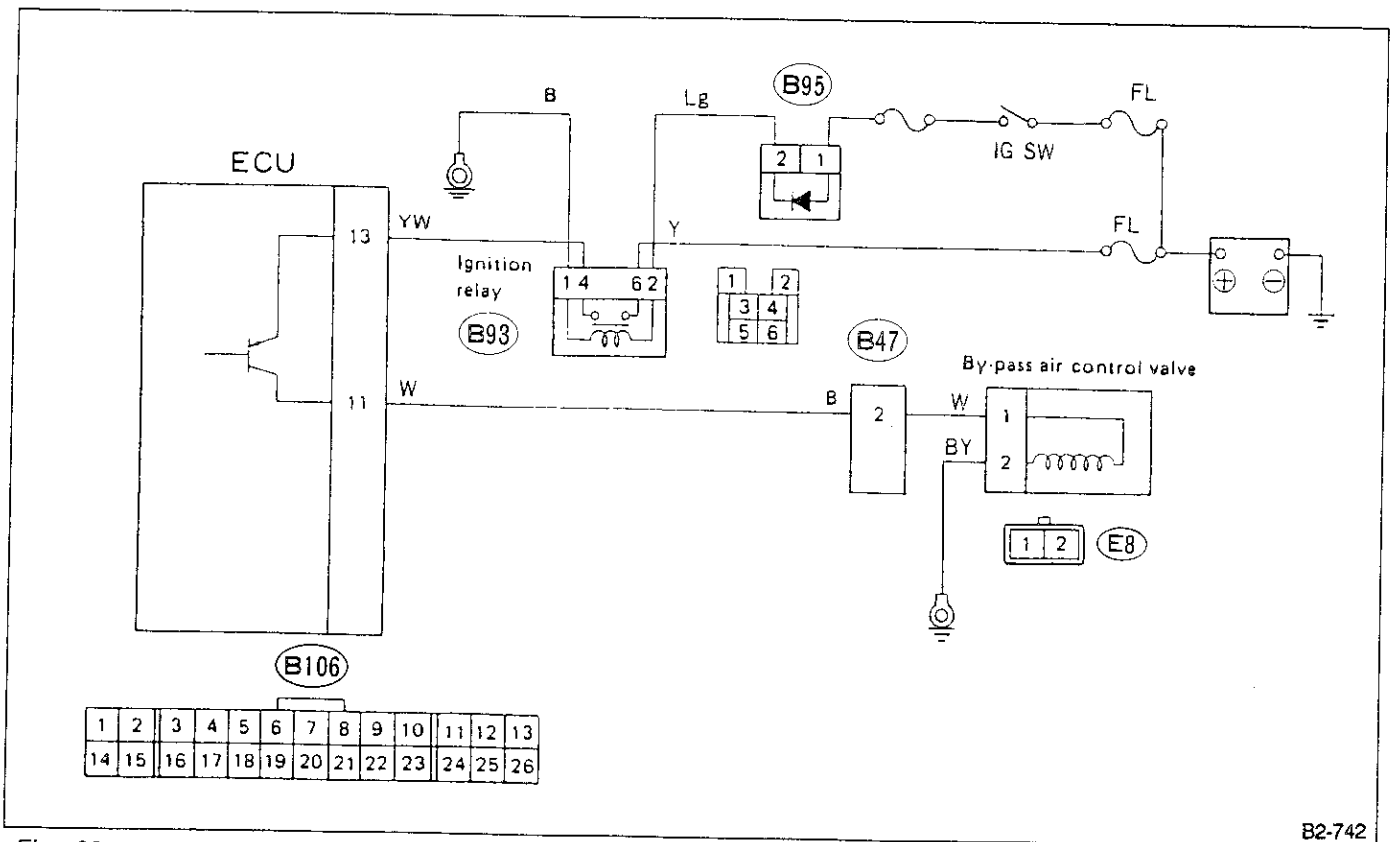
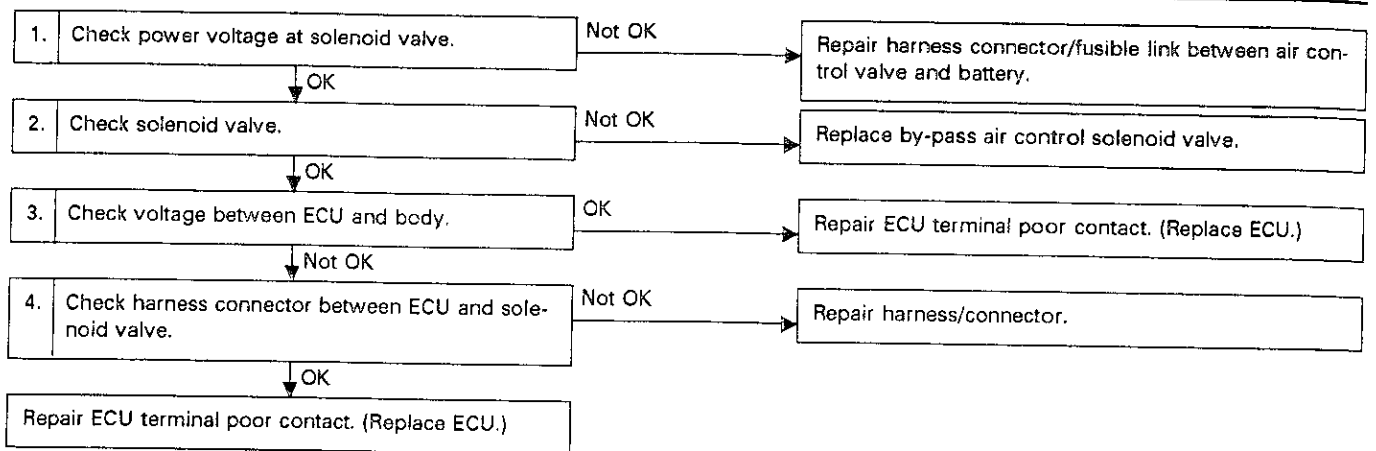
Specified Data: QA F08

0.8 — 1.2 V

H: TROUBLE CODE (24) — BY-PASS AIR CONTROL SOLENOID VALVE —

CONTENT OF DIAGNOSIS:
By-pass air control solenoid valve inoperative

TROUBLE SYMPTOM:
 • Erroneous idling
 • Engine stall
 • Engine breathing



B2-742

Fig. 60

1. CHECK POWER VOLTAGE AT SOLENOID VALVE.

- 1) Turn ignition switch to "ON".
- 2) Measure voltage between solenoid valve connector terminal and body.

Connector & Terminal/Specified voltage:
(B106) No. 13 — Body/10 V, min.

2. CHECK SOLENOID VALVE.

- 1) Disconnect connector from control valve.
- 2) Measure resistance between solenoid valve terminals.

Terminal/Specified resistance:
No. 1 — No. 2/5 — 7 Ω

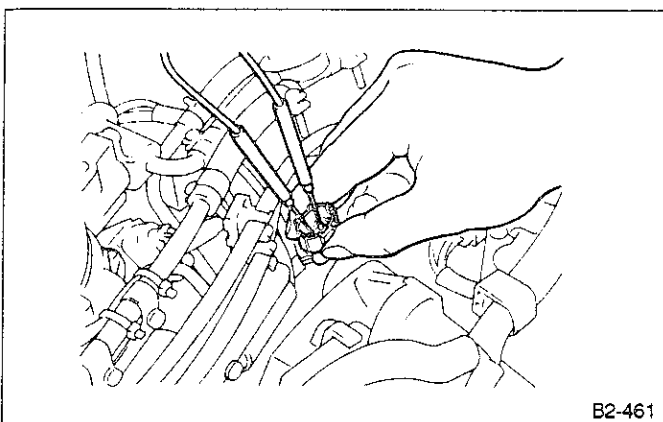


Fig. 61

3. CHECK VOLTAGE BETWEEN ECU AND BODY.

- 1) Turn ignition switch to "ON".
- 2) Measure voltage between ECU connector terminal and body.

Connector & Terminal/Specified voltage:
(B106) No. 11 — Body/*Approx. 10 V

*: As the output signal is a pulse signal, this inspection data varies with the ability of the tester.

4. CHECK HARNESS CONNECTOR BETWEEN ECU AND SOLENOID VALVE.

- 1) Disconnect connectors from ECU and solenoid valve.
- 2) Measure resistance between ECU connector and solenoid valve connector.

Connector & Terminal/Specified resistance:
(B106) No. 11 — (E8) No. 1/0 Ω
(B106) No. 24 — (E8) No. 2/0 Ω

- 3) Measure resistance between solenoid valve connector and body.

Connector & Terminal/Specified resistance:
(E8) No. 1 — Body/1 MΩ min.
(E8) No. 2 — Body/1 MΩ min.

• SELECT MONITOR FUNCTION MODE

Mode: F12
Condition: Engine at idle
Specified Data: ISC F12
 10 — 50%

I: TROUBLE CODE (31) — THROTTLE SENSOR —

CONTENT OF DIAGNOSIS:

Abnormal voltage input entered from throttle sensor.

TROUBLE SYMPTOM:

- Erroneous idling
- Engine stall
- Poor driving performance

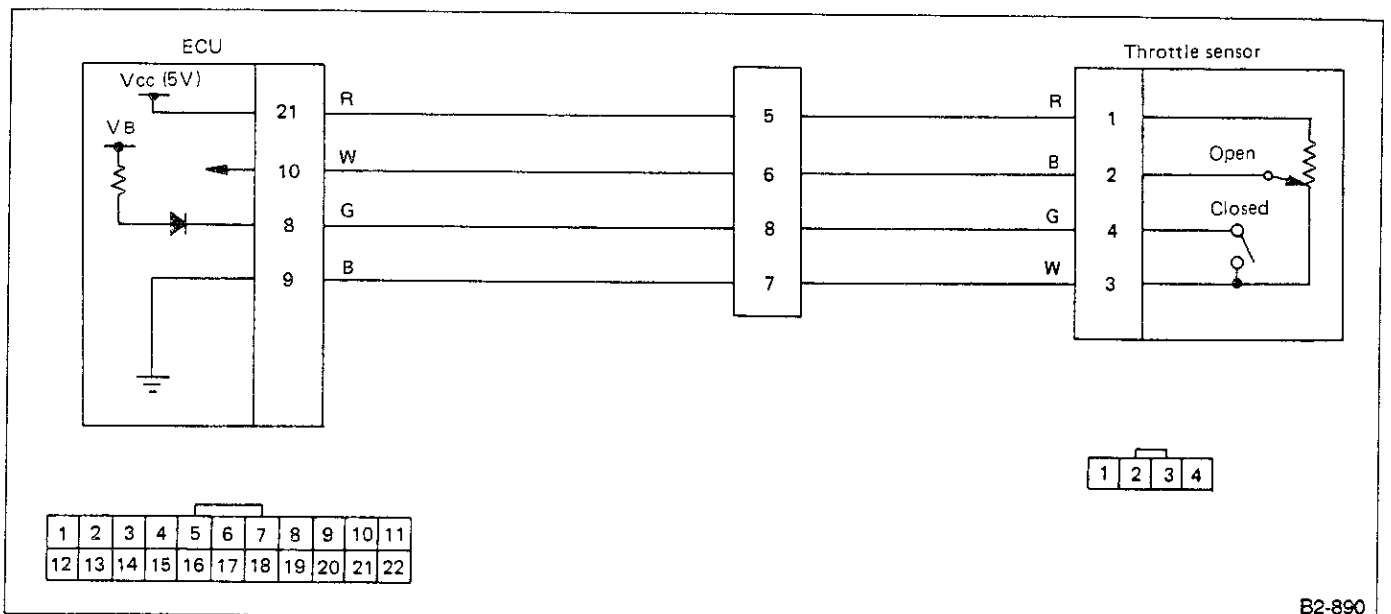
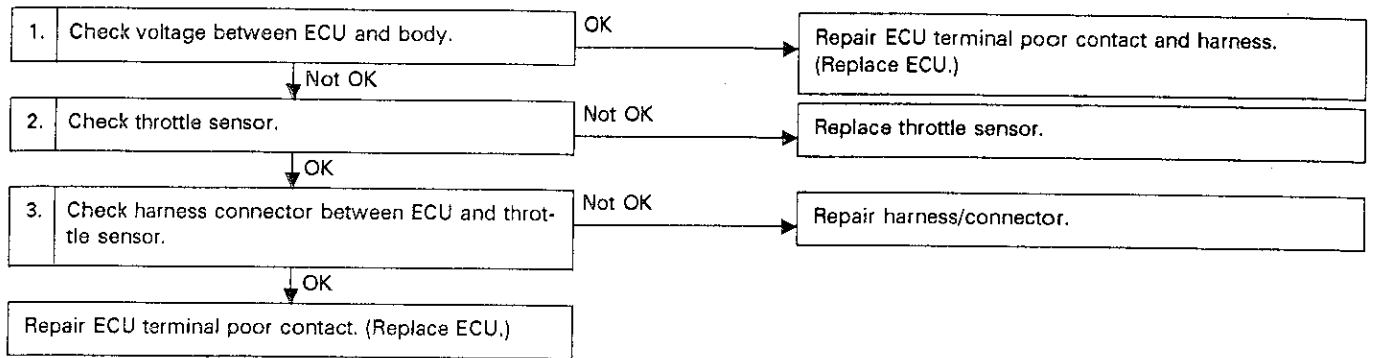


Fig. 62

B2-890

1. CHECK VOLTAGE BETWEEN ECU AND BODY.

- 1) Turn ignition switch to "ON".
- 2) Measure voltage between ECU connector terminal and body.

Connector & Terminal/Specified voltage:
 (B126) No. 10 — Body/
 Approx. 0.5 V (Throttle is fully closed.)
 Approx. 4.2 V (Throttle is fully open.)
 (Ensure voltage smoothly decreases as throttle valve changes from "closed" to "open".)
 (B126) No. 21 — Body/5 V
 (B126) No. 9 — Body/0 V

2. CHECK THROTTLE SENSOR.

- 1) Disconnect connector from throttle sensor.
- 2) Measure resistance between throttle sensor terminals.

Terminal/Specified resistance:
 No. 1 — No. 3/Approx. 5 k Ω

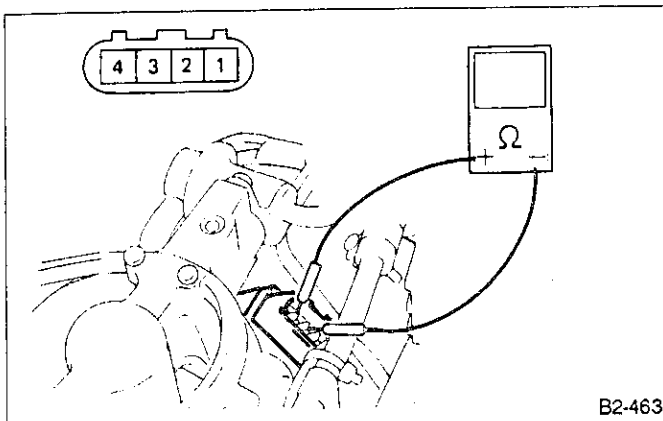


Fig. 63

- 3) Measure resistance between terminals while slowly opening throttle valve from the "closed" position.

Terminal/Specified resistance:
 No. 1 — No. 2/ Approx. 1 k Ω (Throttle is fully closed.)
 Approx. 4.3 k Ω (Throttle is fully open.)
 Ensure resistance increases in response to throttle valve opening.

3. CHECK HARNESS CONNECTOR BETWEEN ECU AND THROTTLE SENSOR.

- 1) Disconnect connectors from ECU and throttle sensor.
- 2) Measure resistance between ECU connector and throttle sensor connectors.

Connector & Terminal/Specified resistance:
 (B126) No. 21 — (E9) No. 1/0 Ω
 (B126) No. 10 — (E9) No. 2/0 Ω
 (B126) No. 9 — (E9) No. 3 /0 Ω

- 3) Measure resistance between throttle sensor connector and body.

Connector & Terminal/Specified resistance:
 (E9) No. 1 — Body/1 M Ω min.
 (E9) No. 2 — Body/1 M Ω min.
 (E9) No. 3 — Body/1 M Ω min.

• SELECT MONITOR FUNCTION MODE

Mode: F10

Condition: Ignition switch ON and throttle valve fully closed and open

Specified Data: THV F10
 0.5 V (Throttle valve fully closed)
 4.2 V (Throttle valve fully open)

J: TROUBLE CODE (32) — O₂ SENSOR —

CONTENT OF DIAGNOSIS:
O₂ sensor inoperative

TROUBLE SYMPTOM:
 • Failure of engine to start
 • Erroneous idling
 • Poor driving performance
 • Engine stall

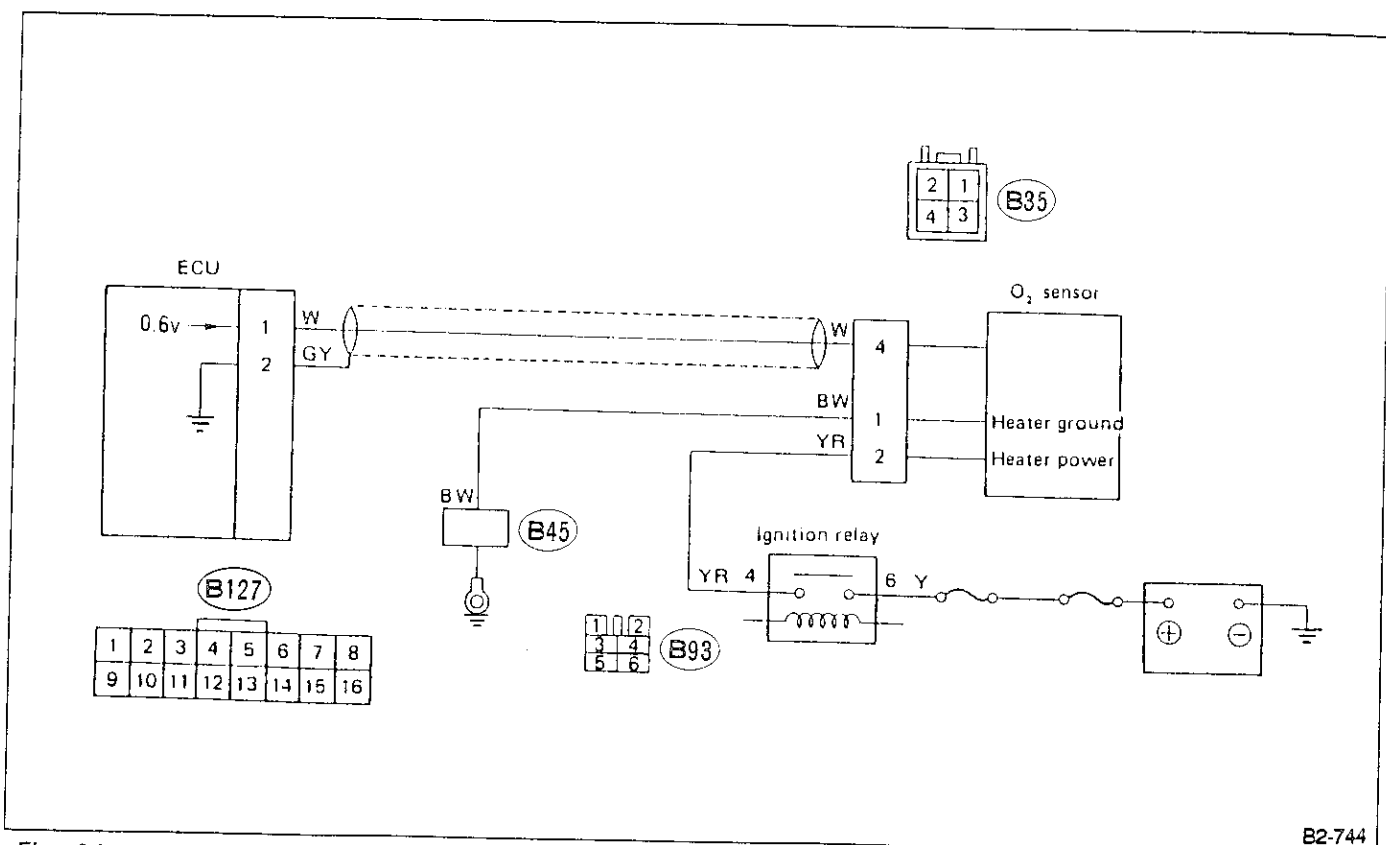
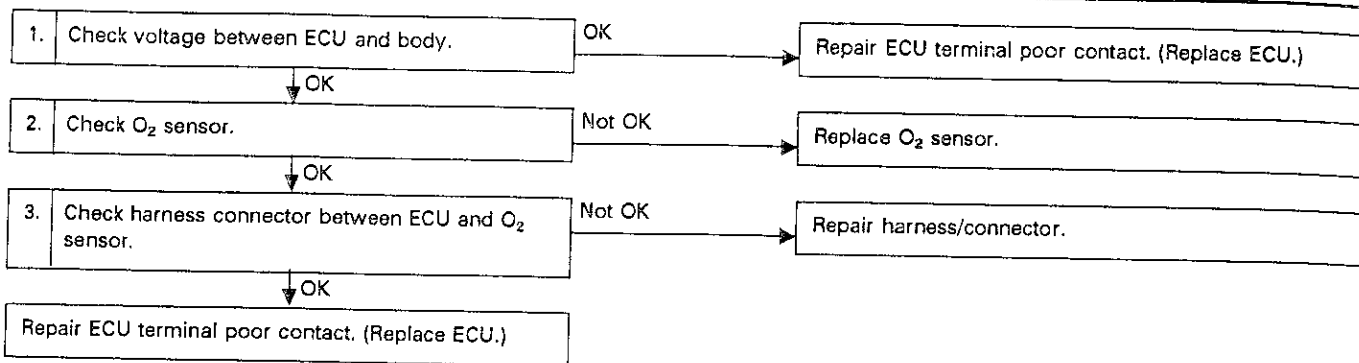


Fig. 64

B2-744

1. CHECK VOLTAGE BETWEEN ECU AND BODY.

Measure voltage between ECU connector terminal and body while idling engine.

Connector & Terminal/Specified voltage:
(B127) No. 1 — Body/0.1 — 0.9 V

Problems in heater circuit causes O₂ sensor to deactivate.

2. CHECK O₂ SENSOR.

- 1) Idle engine.
- 2) Disconnect O₂ sensor connector.
- 3) Measure voltage between O₂ sensor terminal and body.

Terminal/Specified voltage:
No. 4 — Body/0.1 — 1.0 V

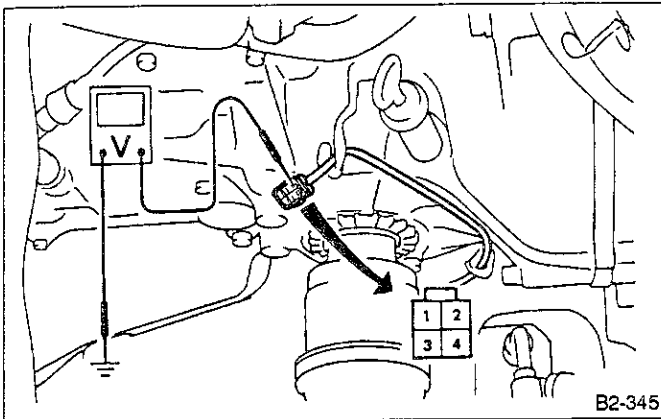


Fig. 65

3. CHECK HARNESS CONNECTOR BETWEEN ECU AND O₂ SENSOR.

- 1) Disconnect connectors from ECU and O₂ sensor.
- 2) Measure resistance between ECU connector and O₂ sensor connector.

Connector & Terminal/Specified resistance:
(B127) No. 1 — (B35) No. 4/0 Ω

- 3) Measure resistance between O₂ sensor connector and body.

Connector & Terminal/Specified resistance:
(B35) No. 4 — Body/1 MΩ min.

• **SELECT MONITOR FUNCTION MODE**

Mode: F13, F14, F15

Condition : After driving at more than 7 MPH for at least one minute with engine warmed up.

Specified Data: O2 F13
0.1 — 0.9 V
O2 max F14
0.7 — 1.0 V
O2 min F15
0 — 0.2V

K: TROUBLE CODE (33) — VEHICLE SPEED SENSOR 2 —

CONTENT OF DIAGNOSIS:
Abnormal voltage input entered from vehicle speed sensor 2

TROUBLE SYMPTOM:

- Erroneous idling
- Engine stall
- Poor driving performance

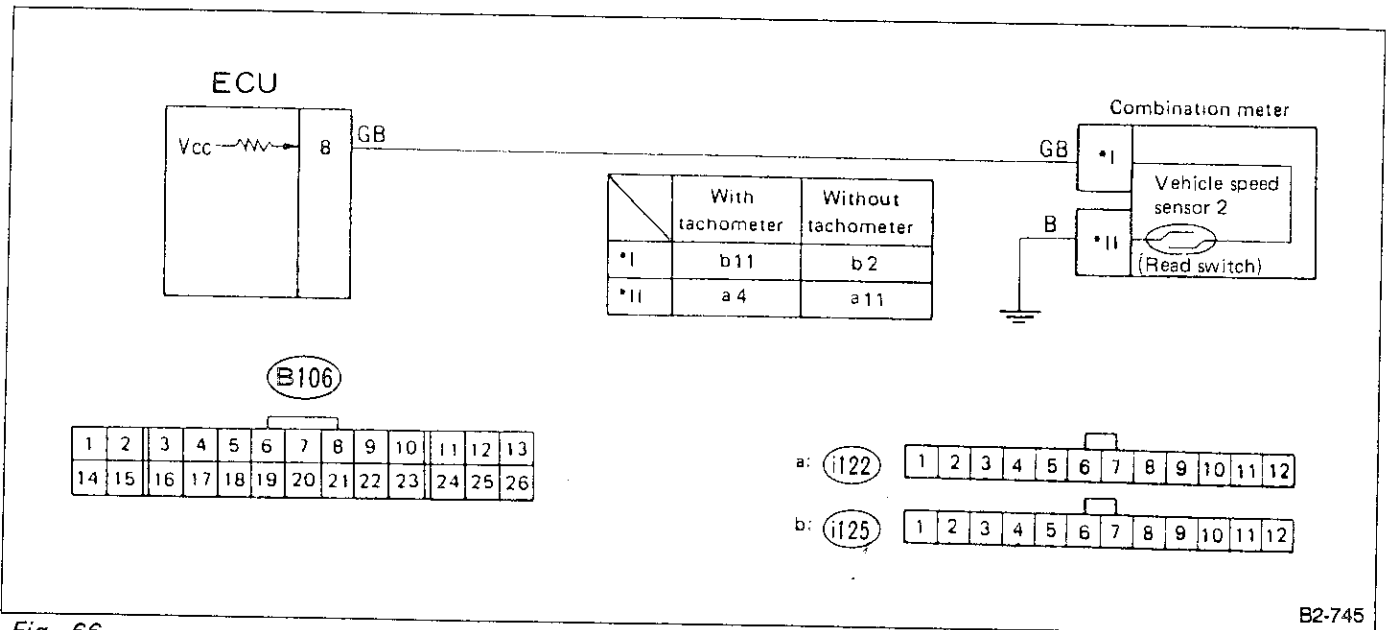
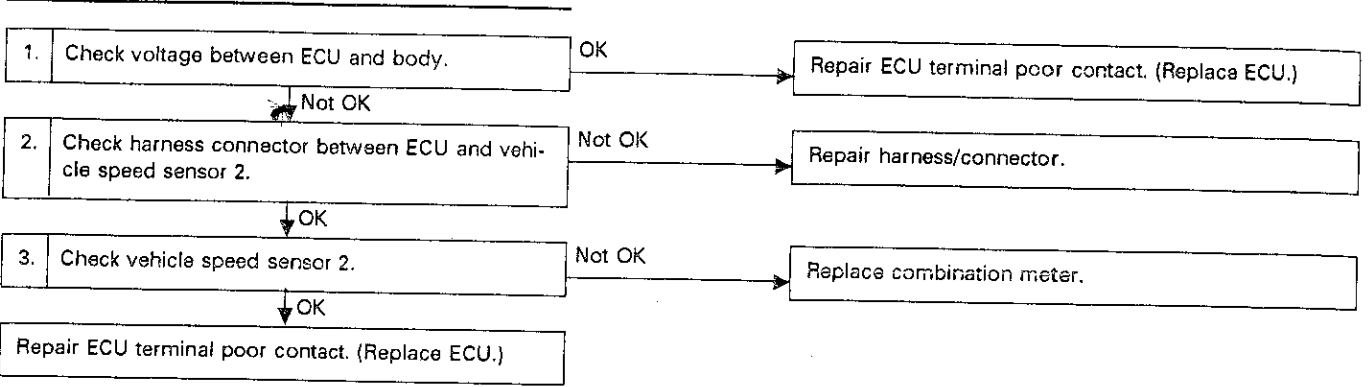


Fig. 66

B2-745

1. CHECK VOLTAGE BETWEEN ECU AND BODY.

- 1) Raise vehicle and support with safety stands.
Ensure all four wheels are off the ground (4WD model).
- 2) Measure voltage between ECU connector terminal and body while slowly driving wheels.

Connector & Terminal/Specified voltage:
(B106) No. 8 — Body/0 ↔ 3 V, min.

2. CHECK HARNESS CONNECTOR BETWEEN ECU AND VEHICLE SPEED SENSOR 2.

- 1) Remove connector from ECU and combination meter.
- 2) Measure resistance between ECU connector and combination meter connector.

Connector & Terminal/Specified resistance:
[With tachometer]
(B106) No. 8 — (i25) No. 11/0 Ω
[Without tachometer]
(B106) No. 8 — (i25) No. 2/0 Ω

- 3) Measure resistance between combination meter connector and body.

Connector & Terminal/Specified resistance:
[With tachometer]
(i25) No. 11 — Body/1 MΩ, min.
(i22) No. 4 — Body/ 0 Ω
[Without tachometer]
(i25) No. 2 — Body/1 MΩ, min.
(i22) No. 11 — Body/ 0 Ω

3. CHECK VEHICLE SPEED SENSOR 2.

- 1) Remove combination meter.
- 2) Disconnect connectors from combination meter.
- 3) Insert a screwdriver into portion usually occupied by meter cable and rotate rotor.
- 4) Check that resistance across combination meter terminals changes, four times per gear rotation.

Connector & Terminal/Specified resistance:
[With tachometer]
(i25) No. 11 — (i22) No. 4/0 ↔ 1 MΩ, min.
[Without tachometer]
(i25) No. 2 — (i22) No. 11/0 ↔ 1 MΩ, min.

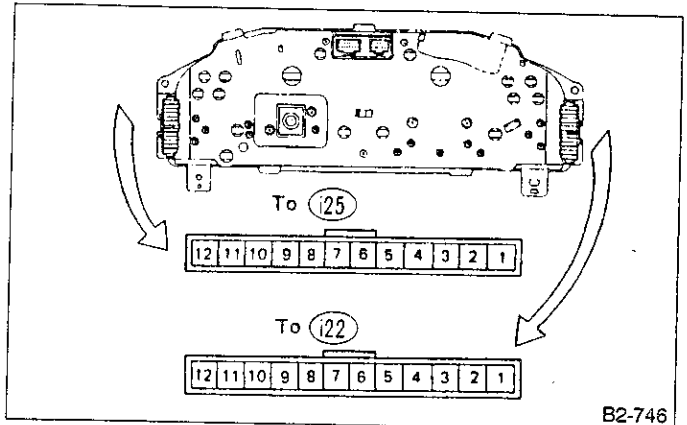


Fig. 67

● SELECT MONITOR FUNCTION MODE

Mode: F03

Condition: While driving vehicle:

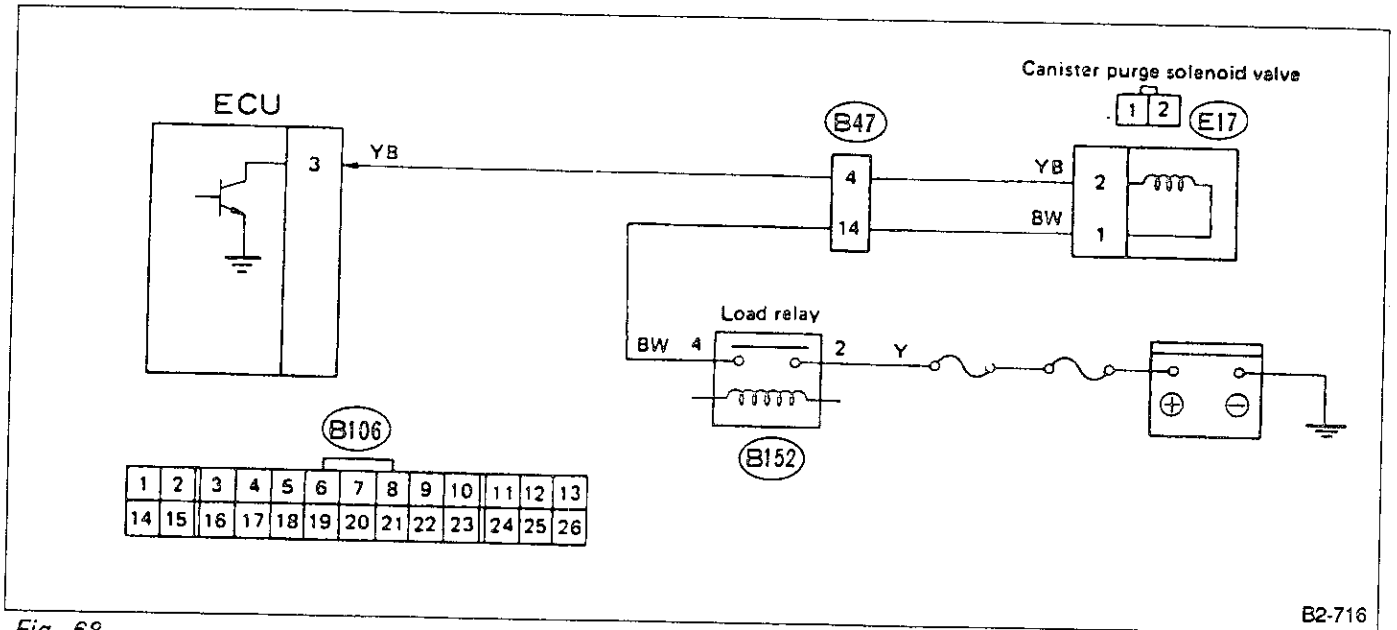
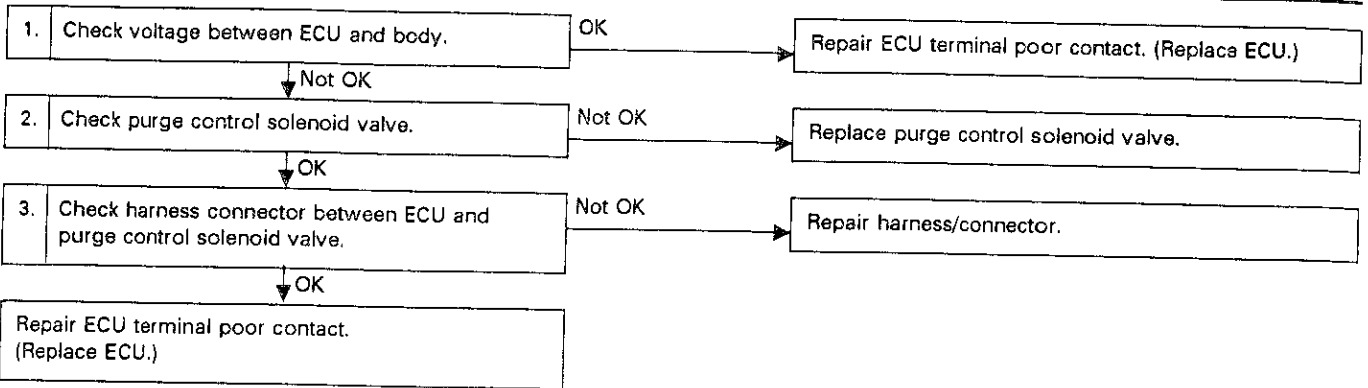
Specified data: VSP F03

(Vehicle speed) km/h

L: TROUBLE CODE (35) — PURGE CONTROL SOLENOID VALVE —

CONTENT OF DIAGNOSIS:
Solenoid valve inoperative

TROUBLE SYMPTOM:
● Erroneous idling



1. CHECK VOLTAGE BETWEEN ECU AND BODY.

- 1) Turn ignition switch to "ON" with engine OFF.
- 2) Measure voltage between ECU connector terminal and body.

Connector & Terminal/Specified voltage:
(B106) No. 3 — Body/10 — 13 V

2. CHECK PURGE CONTROL SOLENOID VALVE.

- 1) Disconnect connector from solenoid valve.
- 2) Measure resistance between solenoid valve terminals.

Specified resistance:
35.5 Ω (at 20°C)

3. CHECK HARNESS CONNECTOR BETWEEN ECU AND PURGE CONTROL SOLENOID VALVE.

- 1) Disconnect connectors from ECU and solenoid valve.
- 2) Measure resistance between ECU connector and solenoid valve connector.

Connector & Terminal/Specified resistance:
(B106) No. 3 — (E17) No. 2/0 Ω

- 3) Measure resistance between solenoid valve connector and body.

Connector & Terminal/Specified resistance:
(E17) No. 2 — Body/1 MΩ min.

- 4) Connect ECU connector and turn ignition switch "ON".

- 5) Measure voltage between solenoid connector and body.

Connector & Terminal/Specified voltage:
(E17) No. 1 — Body/10 — 13 V

• **SELECT MONITOR FUNCTION MODE**

Mode: FA1

LED No.: 7

ON/OFF Signal: LED OFF (Solenoid OFF)
LED ON (Solenoid ON)

M: TROUBLE CODE (42) — IDLE SWITCH —

CONTENT OF DIAGNOSIS:
Abnormal voltage input entered from idle switch

TROUBLE SYMPTOM:
• Erroneous idling
• Engine stall
• Poor driving performance

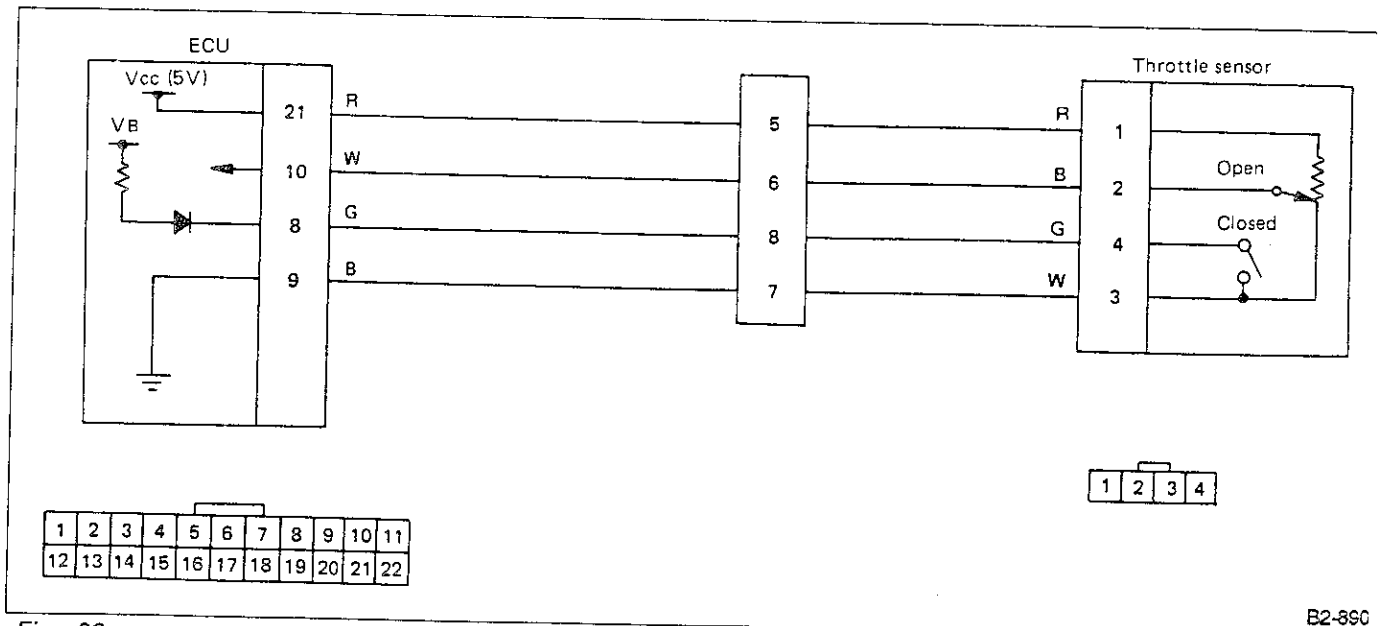
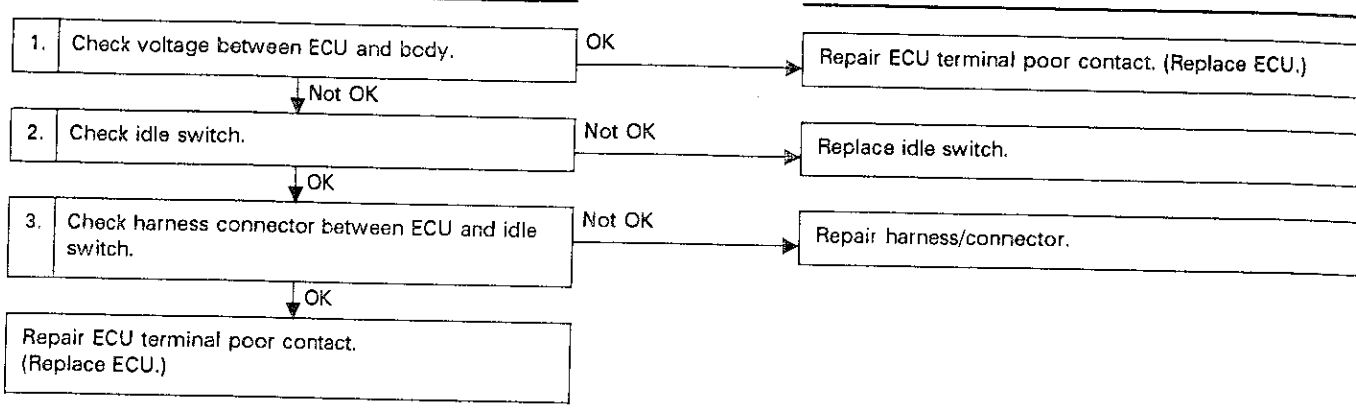


Fig. 69

B2-890

1. CHECK VOLTAGE BETWEEN ECU AND BODY.

- 1) Turn ignition switch to "ON".
- 2) Measure voltage between ECU connector terminal and body.

Connector & Terminal/Specified voltage:
 (B126) No. 8 — Body/ 0 V (Throttle is fully closed.)
 10 — 13 V (Throttle is open.)

2. CHECK IDLE SWITCH.

- 1) Disconnect connector from throttle sensor.
- 2) Check continuity between throttle sensor idle switch terminals.

Terminal/Specified resistance:
 No. 3 — No. 4/0 Ω (Throttle is fully closed.)
 1 M Ω min. (Throttle is fully open.)

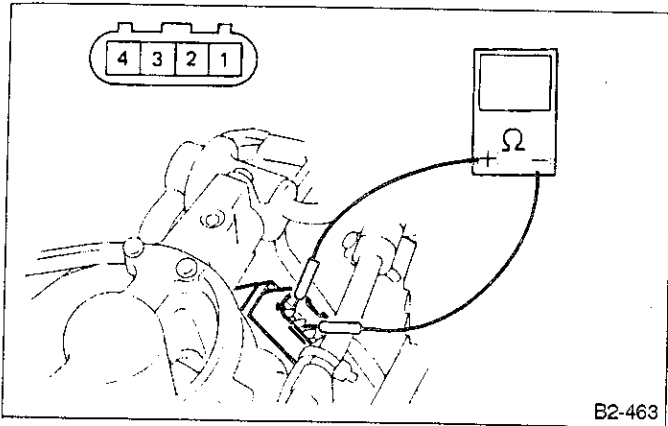


Fig. 70

B2-463

3. CHECK HARNESS CONNECTOR BETWEEN ECU AND IDLE SWITCH.

- 1) Disconnect connectors from ECU and throttle sensor.
- 2) Measure resistance between ECU connector and throttle sensor connector.

Connector & Terminal/Specified resistance:
 (B126) No. 8 — (E9) No. 4/0 Ω
 (B126) No. 9 — (E9) No. 3/0 Ω

- 3) Measure resistance between throttle sensor connector and body.

Connector & Terminal/Specified resistance:
 (E9) No. 4 — Body/1 M Ω min.
 (E9) No. 3 — Body/1 M Ω min.

• SELECT MONITOR FUNCTION MODE

Mode: FA1
LED No.: 1
Condition: Ignition switch ON
ON/OFF Signal:
 LED OFF (Idle switch OFF)
 LED ON (Idle switch ON)

N: TROUBLE CODE (51) — NEUTRAL SWITCH (MT) —

CONTENT OF DIAGNOSIS:
Abnormal signal entered from neutral switch

TROUBLE SYMPTOM:
Erroneous idling

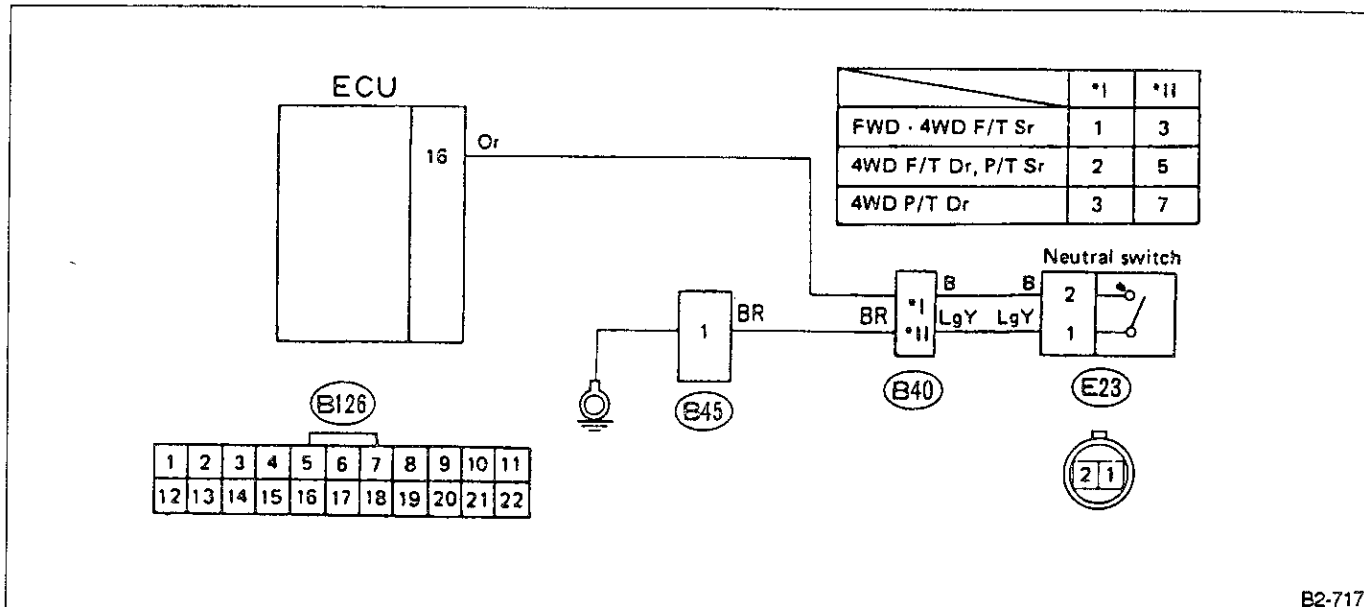
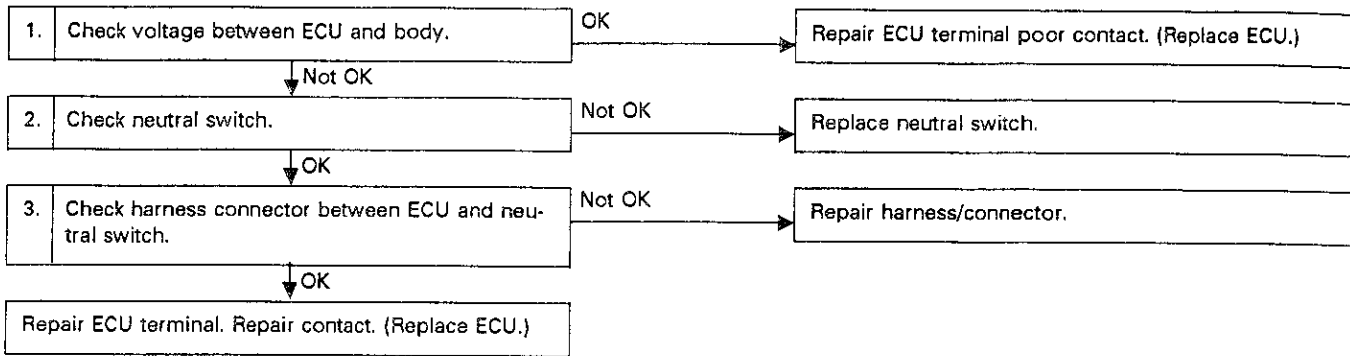


Fig. 71

B2-717

1. CHECK VOLTAGE BETWEEN ECU AND BODY.

- 1) Turn ignition switch to "ON".
- 2) Measure voltage between ECU connector terminal and body.

Connector & Terminal/Specified voltage:
 (B126) No. 16 — Body/10 — 13 V (Neutral position)
 0 V (Other than neutral position)

2. CHECK NEUTRAL SWITCH.

- 1) Disconnect transmission connectors.
- 2) Measure resistance between neutral switch terminals while shifting shift lever from Neutral to any other position.

Connector & Terminal / Specified resistance:
 (E23) No. 1 — No. 2 / 1 MΩ min.(Neutral position)
 0 Ω (Other than neutral position)

3. CHECK HARNESS CONNECTOR BETWEEN ECU AND NEUTRAL SWITCH.

- 1) Disconnect connectors from ECU and neutral switch.
- 2) Measure resistance between ECU connector and neutral switch connector.

Connector & Terminal/Specified resistance:
 (B126) No. 16 — (E23) No. 2/0 Ω

- 3) Measure resistance between neutral switch connector and body.

Connector & Terminal/Specified resistance:
 (E23) No. 2 — Body/1 MΩ min.
 (E23) No. 1 — Body/0 Ω

• SELECT MONITOR FUNCTION MODE

Mode: FA0
 LED No.: 7
 Condition: Ignition switch ON
 ON/OFF Signal:
 LED OFF (Other than neutral position)
 LED ON (Neutral position)

O: TROUBLE CODE (51) — INHIBITOR SWITCH (AT) —

CONTENT OF DIAGNOSIS:
Abnormal signal entered from inhibitor switch

TROUBLE SYMPTOM:
Erroneous idling

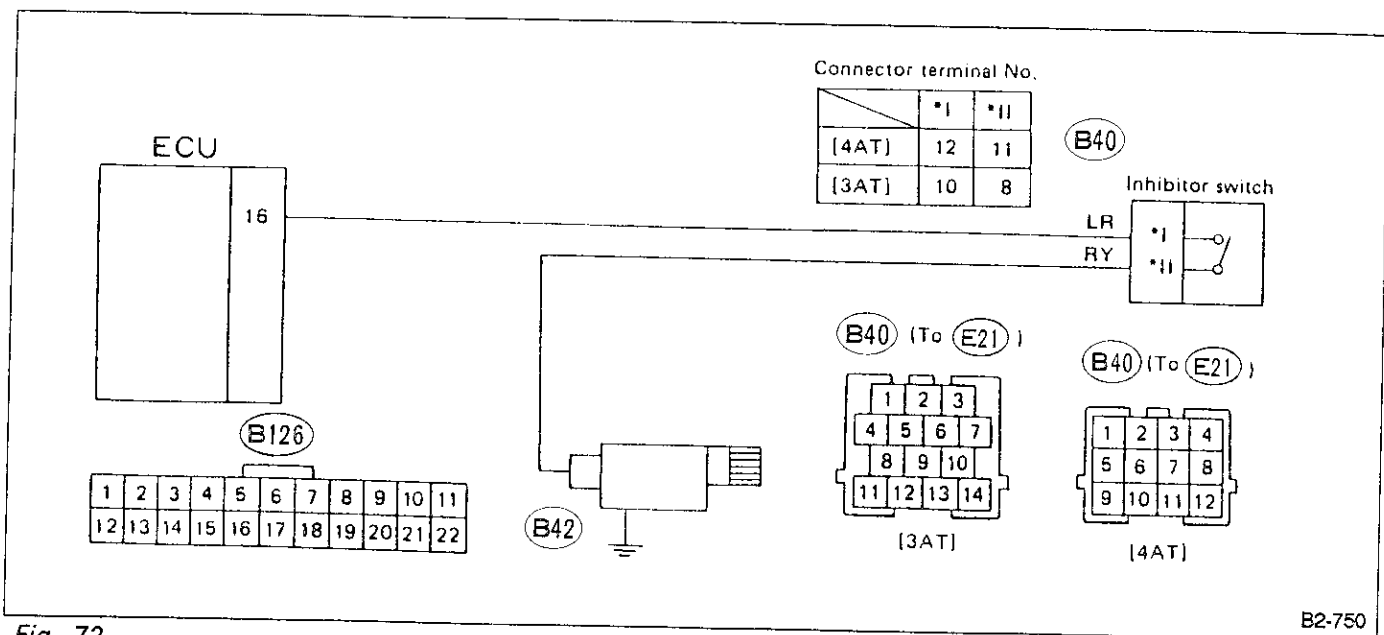
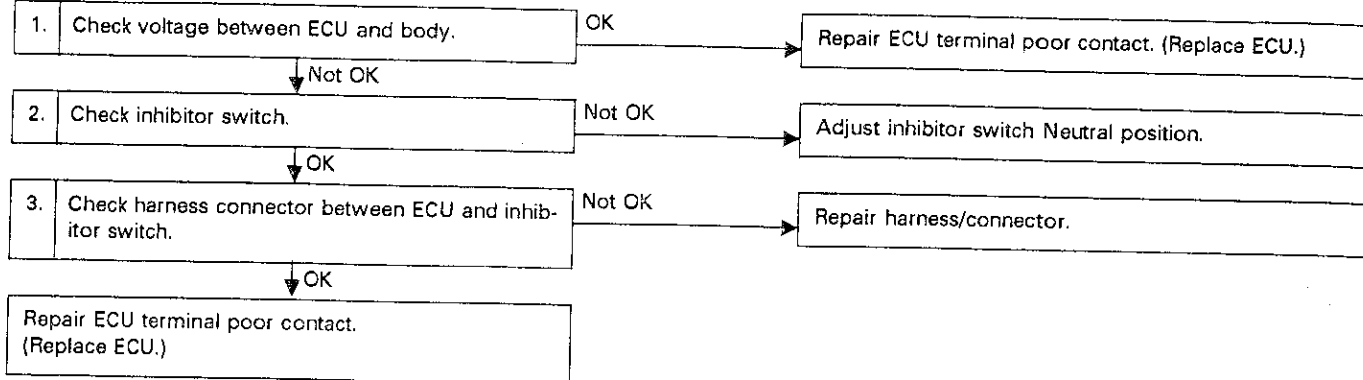


Fig. 72

B2-750

1. CHECK VOLTAGE BETWEEN ECU AND BODY.

- 1) Turn ignition switch to "ON".
- 2) Measure voltage between ECU connector terminal and body.

Connector & Terminal/Specified voltage:
 (B126) No. 16 — Body/0 V (N and P Range)
 10 — 13 V (Other)

2. CHECK INHIBITOR SWITCH.

- 1) Disconnect transmission connectors.
- 2) Measure resistance between inhibitor switch terminals while shifting select lever from Neutral to any other position.

Connector & Terminal/Specified resistance:
[4AT]
 (E21) No. 12 — No. 11/ 0 Ω (N and P Range)
 1 MΩ min. (Other)
[3AT]
 (E21) No. 10 — No. 8/ 0 Ω (N and P Range)
 1 MΩ min. (Other)

3. CHECK HARNESS CONNECTOR BETWEEN ECU AND INHIBITOR SWITCH.

- 1) Disconnect connectors from ECU and inhibitor switch.
- 2) Measure resistance between ECU connector and inhibitor switch connector.

Connector & Terminal/Specified resistance:
 (B126) No. 16 — (B40) No. 12/0 Ω [4AT]
 (B126) No. 16 — (B40) No. 10/0 Ω [3AT]

- 3) Measure resistance between inhibitor switch connector and body.

Connector & Terminal/Specified resistance:
[4AT]
 (B40) No. 12 — Body/1 MΩ min.
 (B40) No. 11 — Body/0 Ω
[3AT]
 (B40) No. 10 — Body/1 MΩ min.
 (B40) No. 8 — Body/0 Ω

● **SELECT MONITOR FUNCTION MODE**

Mode: FA0
LED No.: 7
Condition: Ignition switch ON
ON/OFF Signal:
 LED OFF (Other than N and P Range)
 LED ON (N and P Range)

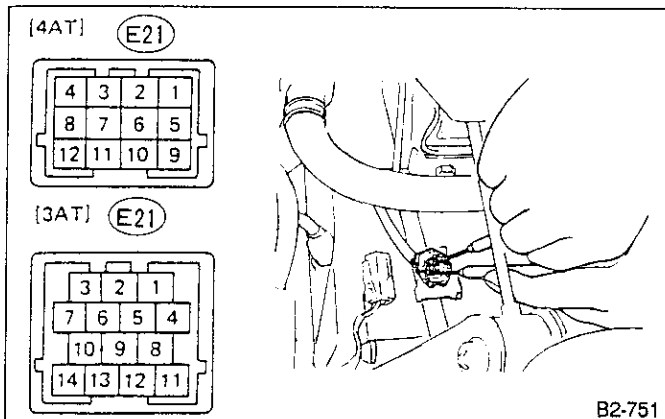


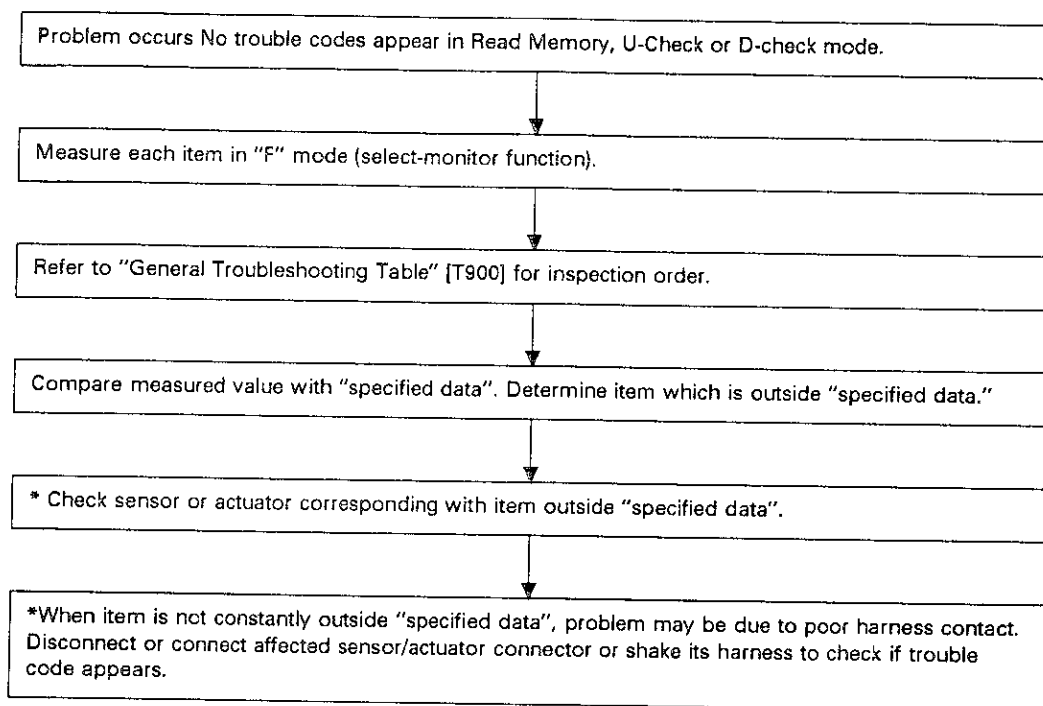
Fig. 73

8. Troubleshooting Chart with Select Monitor

A: BASIC TROUBLESHOOTING CHART

If no trouble codes appear in the Read Memory, U-check or D-check mode (although problems have occurred or are occurring), measure performance characteristics of sensors, actuators, etc., in the "F" mode (select-monitor function), and compare with the "basic data" to determine the cause of problems.

Applicable cartridge of select monitor: No. 498348800



B: MODE F01 — Battery voltage (VB) —

CONDITION:
 (1) Ignition switch "ON"
 (2) Idling after warm-up

SPECIFIED DATA:
 10 — 12 V (Ignition switch ON, engine OFF)
 12 — 14 V (Engine at idle)

• Probable cause (item outside "specified data")

1. Battery

Check battery voltage and electrolyte's specific gravity.

2. Charging system

• Check regulating voltage. (under no-load)
 • Check alternator.

C: MODE F03 — Vehicle speed signal (VSP) —

CONDITION:
 Raise vehicle until all wheels are off ground, and support with safety stands. Operate vehicle at constant speed.

SPECIFICATION DATA :
 Compare speedometer with monitor indications.

• Probable cause (item outside "specified data")

1. Vehicle speed sensor 2

Check if sensor is in operation. (Refer to [T7K0].)

↓ OK

Replace ECU.

F02 = Vehicle speed signal: Vehicle speed is indicated in mile per hour (MPH).

D: MODE F04 — Engine speed (EREV) —

CONDITION:
Operate engine at constant speed.

SPECIFIED DATA:
Compare engine speeds indicated on engine tester monitor.

• Probable cause (if outside specified data)

1. Cam angle sensor

Check cam angle sensor output signal. (Refer to [T7C0].)

↓ OK

2. Crank angle sensor

Check crank angle sensor output signal. (Refer to [T7A0].)

↓ OK

Replace ECU.

E: MODE F06 — Water temperature sensor signal (TW) —

CONDITION:
Idling after warm-up

SPECIFIED DATA:
80 — 95 deg C

• Probable cause (if outside specified data)

1. Water temperature sensor

Check water temperature sensor. (Refer to [T7E0].)

↓ OK

Replace ECU.

F05 = Water temperature signal (TW): To be indicated in "deg F".

F: MODE F07 — Ignition timing —

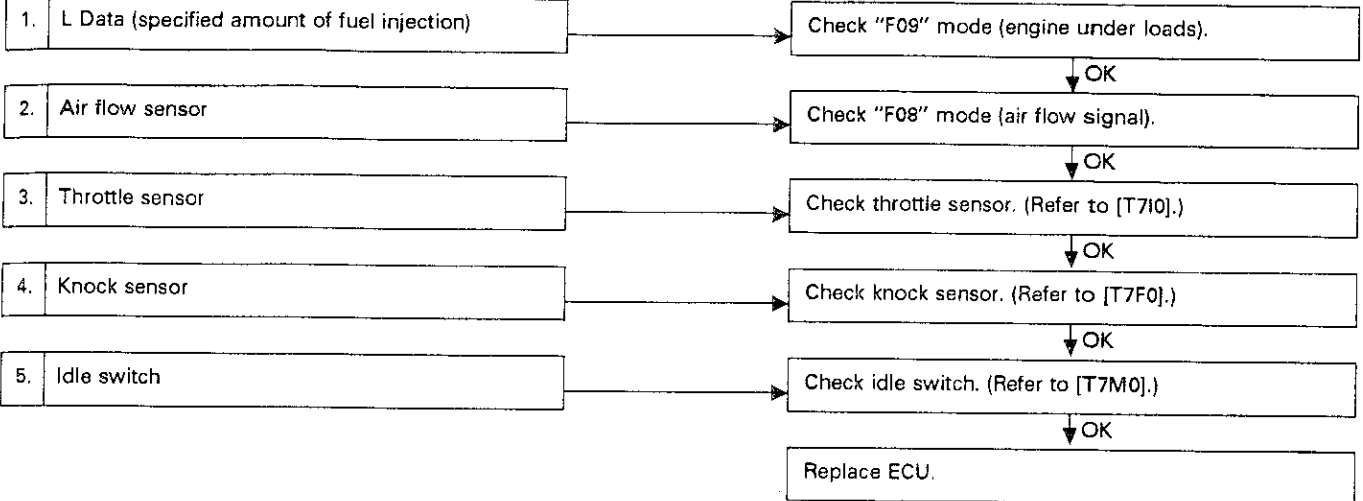
CONDITION:

- (1) While idling after warm-up
- (2) Gear in neutral position

SPECIFIED DATA:

10 deg — 30 deg

• Probable cause (if items outside specified data)



G: MODE F08 — Air flow signal (QA) —

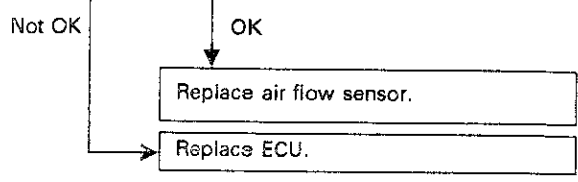
CONDITION:
 (1) Idling after warm-up
 (2) Air conditioner "OFF"

SPECIFIED DATA:
 1.0 — 1.6 V

• Probable cause (if outside specified data)

- 1. Air flow sensor

Compare air flow sensor signal voltage with specified data QA.
 (QA voltage equals air flow sensor signal voltage.)



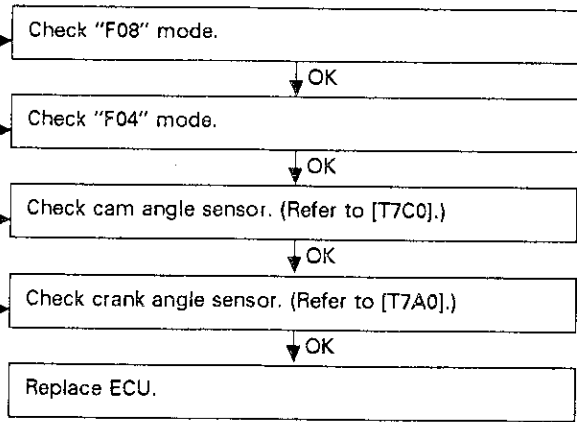
H: MODE F09 — Engine under loads (L DATA) —

CONDITION:
 Idling after warm-up

SPECIFIED DATA:
 30 — 60

• Probable cause (if outside specified data)

- 1. Air flow sensor
- 2. Engine speed (rpm)
- 3. Cam angle sensor
- 4. Crank angle sensor

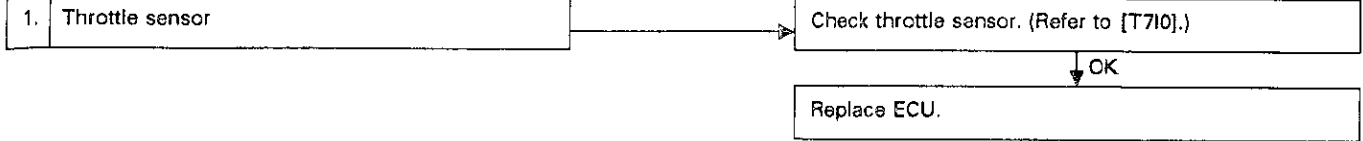


I: MODE F10 — Throttle sensor signal —

CONDITION:
Check while changing from "fully-closed" to "fully-open" throttle valve.

SPECIFIED DATA:
0.5 V — 4.2 V
*Engine throttle change must be smooth.

● Probable cause (if outside specified data)

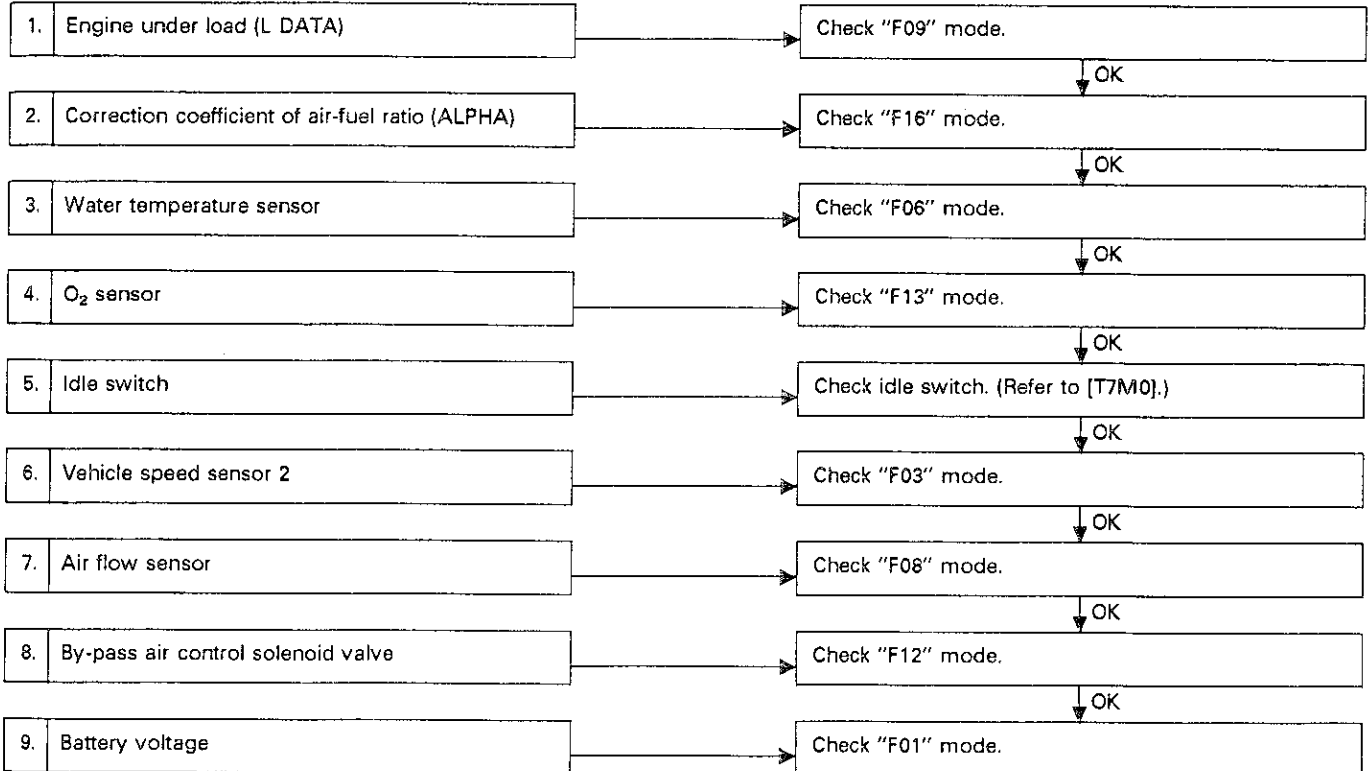


J: MODE F11 — Fuel injection duration (TIM) —

CONDITION:
Idling after warm-up

SPECIFIED DATA:
0.6 — 1.6 ms

● Probable cause (if outside specified data)



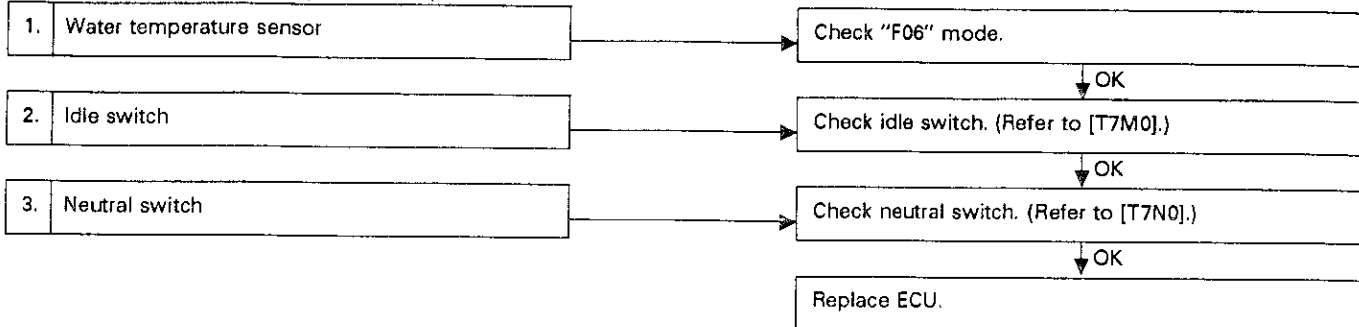
K: MODE F12 — By-pass air control solenoid valve (ISC) —**CONDITIONS:**

- (1) Idling after warm-up
- (2) Air conditioner "OFF"
- (3) Radiator fan "OFF"
- (4) Battery voltage: Greater than 13 volts

SPECIFIED DATA:

10 — 50%

● Probable cause (if outside specified data)

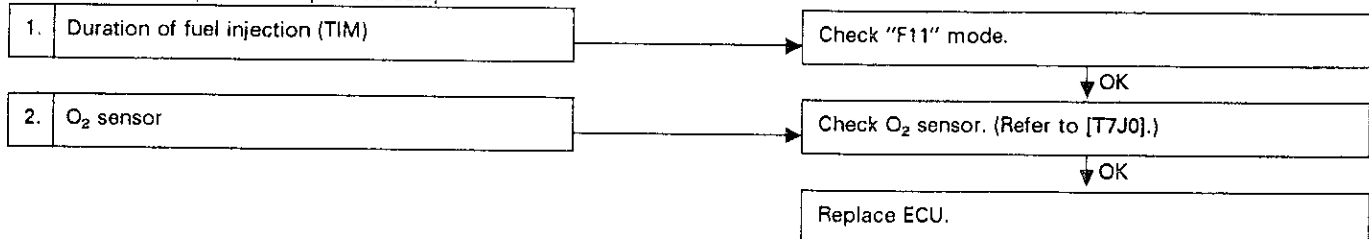
**L: MODE F13 — O₂ sensor (O₂) —****CONDITION:**

Engine 2,000 rpm after warm-up

SPECIFIED DATA:

0.0 — 0.9 V

● Probable cause (if outside specified data)

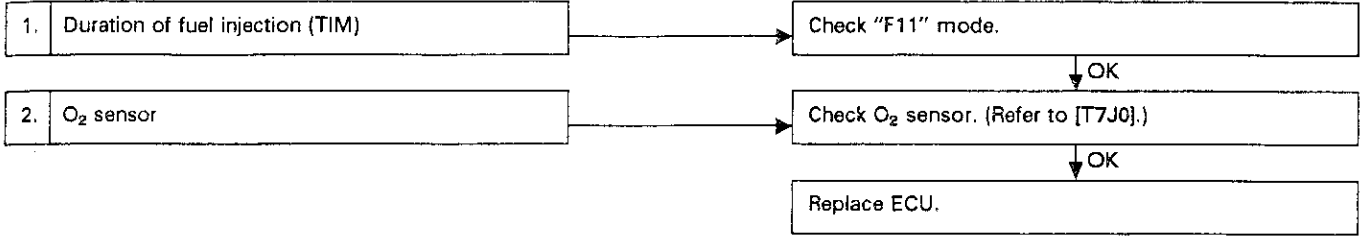


M: MODE F14 — Maximum O₂ sensor signal voltage (O₂ Max.) —

CONDITION:
Engine 2,000 rpm after warm-up

SPECIFIED DATA:
0.7 — 0.9 V

• Probable cause (if outside specified data)

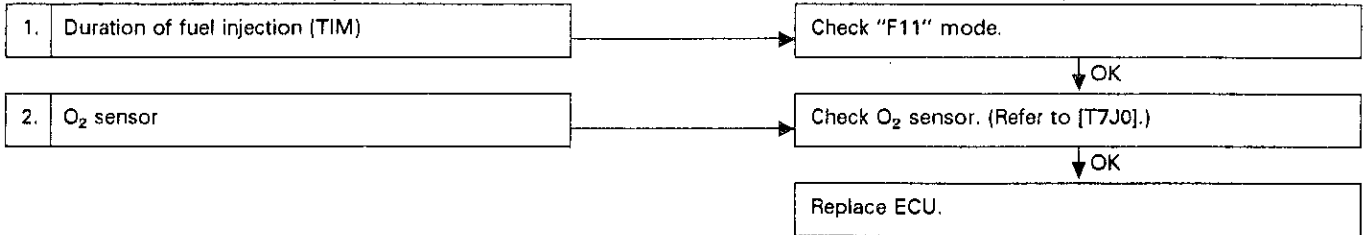


N: MODE F15 — Minimum O₂ sensor signal voltage (O₂ Min.) —

CONDITION:
Engine 2,000 rpm after warm-up

SPECIFIED DATA:
0.00 — 0.11 V

• Probable cause (if outside date)

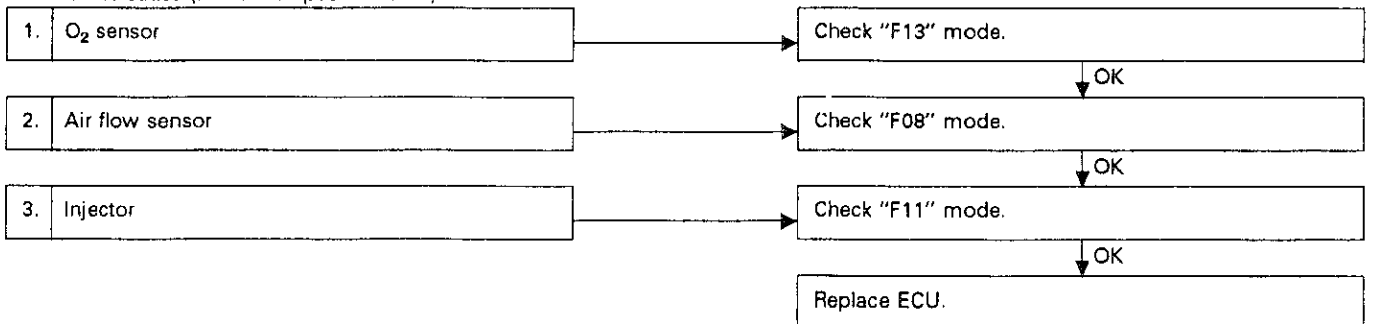


O: MODE F16 — Correction coefficient of air-fuel ratio (ALPHA) —

CONDITION:
Idling after warm-up

SPECIFIED DATA:
- 25 to + 25%

• Probable cause (if outside specified data)



P: MODE F17 — Correction value of ignition timing (RTRD) —

CONDITION:
—

SPECIFIED DATA:
- 10 to + 10 deg

● Probable cause (if outside specified data)

- 1. Knock sensor

Check knock sensor. (Refer to [T7F0].)

↓ OK

Replace ECU.

9. General Troubleshooting Table

Priority of "parts to check" is shown by figures (1, 2, 3, 16).

Parts to check		ECU power supply	Air flow sensor	Water temperature sensor	Idle switch	Throttle sensor	Fuel pump	Pressure regulator	Fuel injector	Igniter (power transistor)	Ignition coil	Spark plug	Knock sensor	Cam angle sensor	Crank angle sensor	By-pass air control solenoid valve	O ₂ sensor
Symptom	Initial combustion does not occur.	1	10	11			5	6	7	2	3	4		8	9		
	Initial combustion occurs.	1		10			2	3	4	5	6	7		8	9	11	
	Engine stalls after initial combustion.	1	2	7		8	4	5	6	11	12	13		9	10	3	
	Rough idling	1	3	12	8	7	4	5	6	9	10	11		13	14	2	15
	Hard to drive at constant speed	1	4	6	8	7	3	2	9	12	12	14		10	10		5
	Poor acceleration/ deceleration	1	2	6	7	8	3	4	5	13	14	15	9	11	12	10	
	Poor return to idle			3	2											1	
	Backfire			3	4	5		6	7					2	1		
	Knocking		1	2				4	6				3		7		
	Excessive fuel consumption		3	4				1	2								
Shocks while driving	1	8						7	4	5	6		2	3			
Poor engine revving		2	3	4	5		1										
Remarks	Include engine ground circuit.																Check hoses.

SUBARU

1992

**SERVICE
MANUAL**



	Page
M MECHANISM AND FUNCTION	2
1. General	2
2. Air Line	4
3. Fuel Line	6
4. Sensor and Switch	8
5. Control System	12
6. Self-diagnosis System	23
7. Turbocharger System	26
S SPECIFICATION AND SERVICE DATA	34
C COMPONENT PARTS	35
1. Turbocharger	35
2. Intercooler	36
W SERVICE PROCEDURE	37
1. Turbocharger System	37
2. Intercooler System	41
T TROUBLESHOOTING	45
1. Precautions	45
2. Pre-inspection	45
3. Troubleshooting Chart for Self-diagnosis System	46
4. Output Modes of Select Monitor	52
5. Control Unit I/O Signal	54
6. Troubleshooting for Engine Starting Failure	57
7. Troubleshooting Chart with Trouble Code	68
8. Troubleshooting Chart with Select Monitor	104
9. General Troubleshooting Table	116

M MECHANISM AND FUNCTION

1. General

The Multi Point Fuel Injection (MPFI) system is a system that supplies the optimum air-fuel mixture to the engine for all the various operating conditions through the use of the latest electronic technology.

With this system fuel, which is pressurized at a constant pressure, is injected into the intake air passage of the cylinder head. The injection quantity of fuel is controlled by an intermittent injection system where the electro-magnetic injection valve (fuel injector) opens only for a short period of time, depending on the quantity of air required for one cycle of operation. In actual operation, the injection quantity is determined by the duration of an electric pulse applied to the fuel injector and this permits simple, yet highly precise metering of the fuel.

Further, all the operating conditions of the engine are converted into electric signals, and this results in additional features of the system, such as large improved adaptability, easier addition of compensating elements etc. The MPFI system also has the following features:

- 1) Reduced emission of harmful exhaust gases.
- 2) Reduced in fuel consumption.
- 3) Increased engine output.
- 4) Superior acceleration and deceleration.
- 5) Superior startability and warm-up performance in cold weather since compensation is made for coolant and intake air temperature.
- 6) Suitable to turbocharger engine.

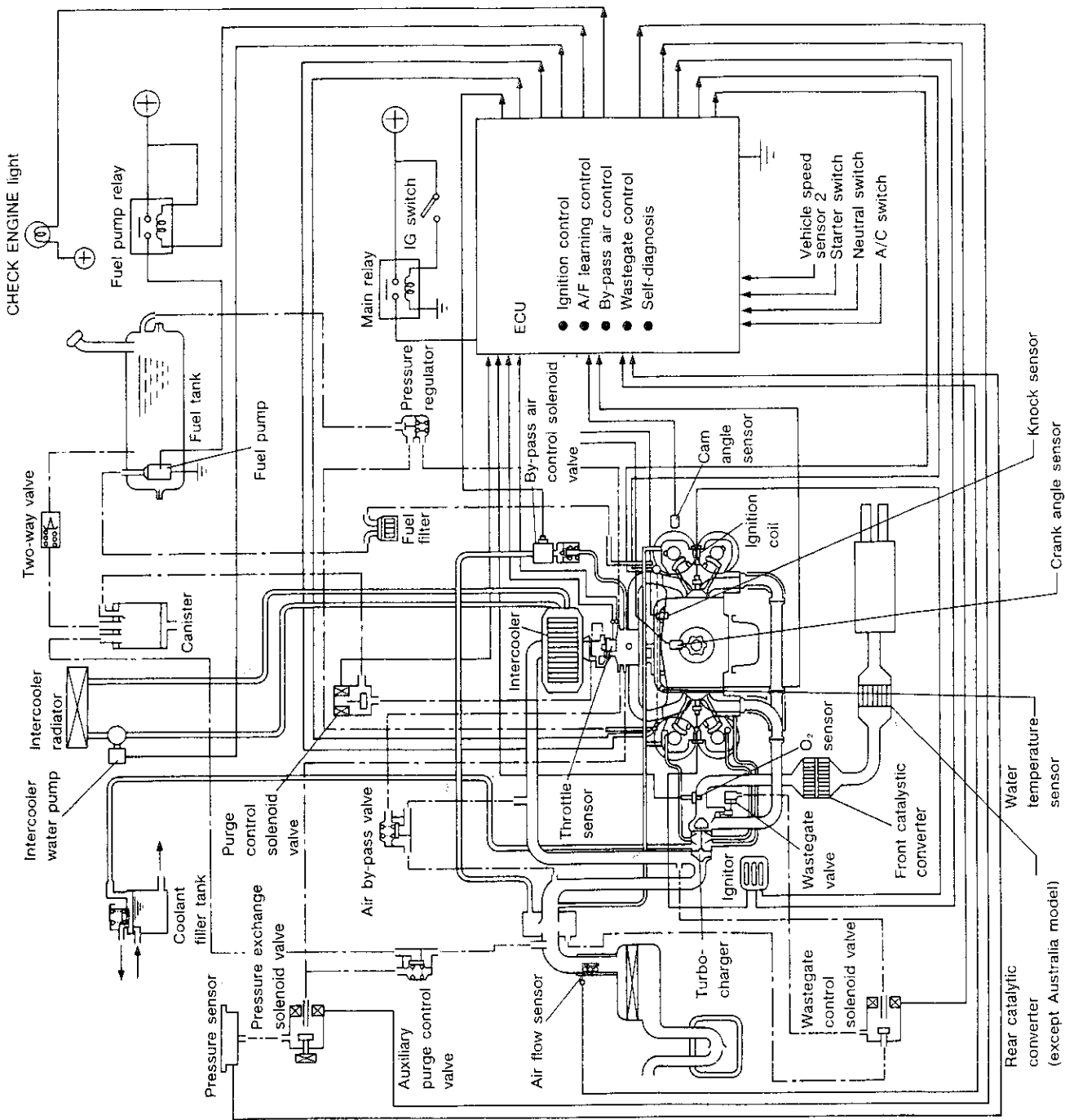


Fig. 1

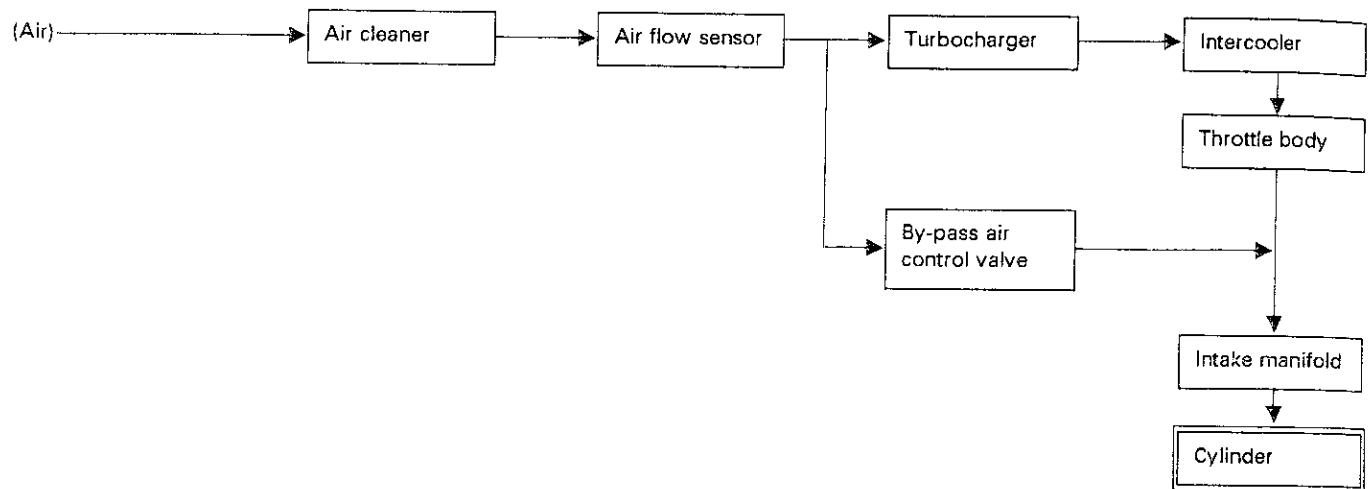
B2-1119

2. Air Line

1. GENERAL

Air which is drawn in and filtered by the air cleaner is metered by the air flow sensor. Air is then super-charged by the turbocharger and cooled down by the intercooler, and sent to the throttle body. From the throttle body, the air is regulated by the open-close

operation of the throttle valve and is delivered to the intake manifold. It is then distributed to the respective cylinders to mix with fuel injected by the fuel injectors. Thus, the air-fuel mixture is delivered into the cylinder. Part of the air branched at the upstream of the throttle body is sent to the by-pass air control valve which regulates engine idle speed.



2. AIR FLOW SENSOR

The MPFI system employs a hot-film type air flow sensor.

These air flow sensors convert the amount of air taken into the engine into an electric signal by utilizing the heat transfer phenomenon between the incoming air and a heating resistor (hot film) located in the air intake. The features of these flow sensor types are as follows:

- 1) High-altitude compensation is made automatically.
- 2) Quick response.
- 3) There are no moving parts.
- 4) They are compact.

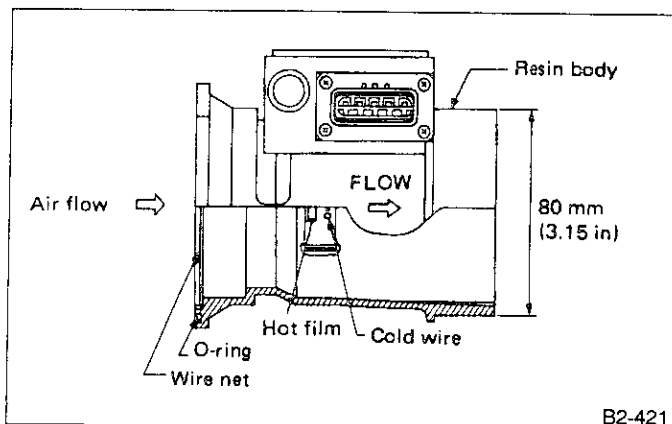


Fig. 2

3. THROTTLE BODY

In response to the depressing stroke of the throttle pedal, the throttle body opens/closes its valve to regulate the air volume to be taken in the combustion chamber.

During idling, the throttle valve is almost fully closed and the air flow through the throttle body is less than that passing through the carburetor.

More than half of the air necessary for idling is supplied to the intake manifold via the by-pass air control valve. And the by-pass air control valve properly controls the number of revolutions in idling, so it does not need to be adjusted.

4. THROTTLE SENSOR

A throttle position sensor is provided with a potentiometer and idle switch interlocked with the throttle valve shaft is utilized.

This throttle position sensor sends the MPFI control unit a potentiometer output signal corresponding to the opening of the throttle valve and an idle switch signal that turns ON only when the throttle is opened nearly to the idle position.

Using these signals, the MPFI control unit precisely controls the air-fuel ratio during acceleration and deceleration as well as idling.

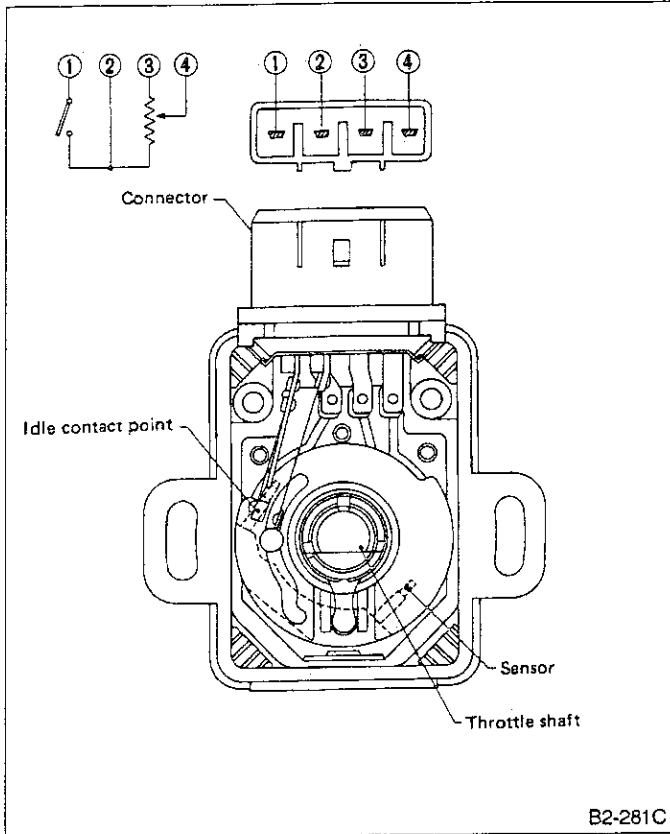


Fig. 3

5. BY-PASS AIR CONTROL VALVE

The by-pass air control valve consists of an air cut valve, duty control valve, intake air passage and a coolant passage.

The air cut valve contains a bimetallic substance which responds to coolant temperature, and a duty control valve which is operated by a signal sent from the ECU. When the coolant temperature is low, the air cut valve is fully opened by the action of the bimetallic substance so that the air flow required for low coolant temperatures is maintained.

The ECU controls the duty control valve to bring the operating engine speed as close to preset idle speed as possible.

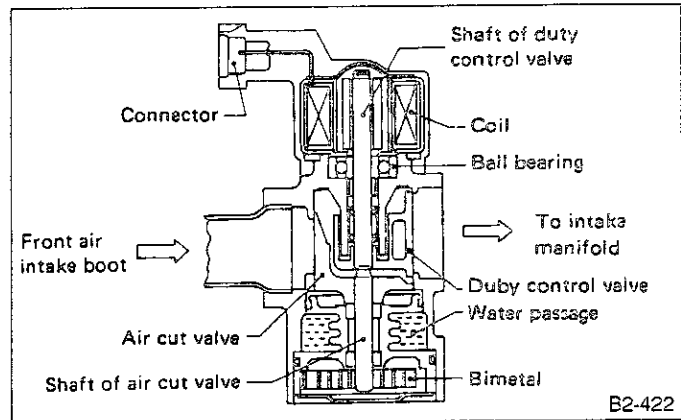


Fig. 4

3. Fuel Line

1. GENERAL

Fuel pressurized by the fuel pump built into the fuel tank is delivered to fuel injectors by way of the fuel pipe and fuel filter. Fuel is regulated to the optimum pressure level by the pressure regulator on the way to the injectors.

From the injectors, fuel is injected into the intake manifold where it is mixed with intake air, and is then delivered to the respective cylinders.

Fuel injection timing and the amount of fuel injected is regulated by the ECU.

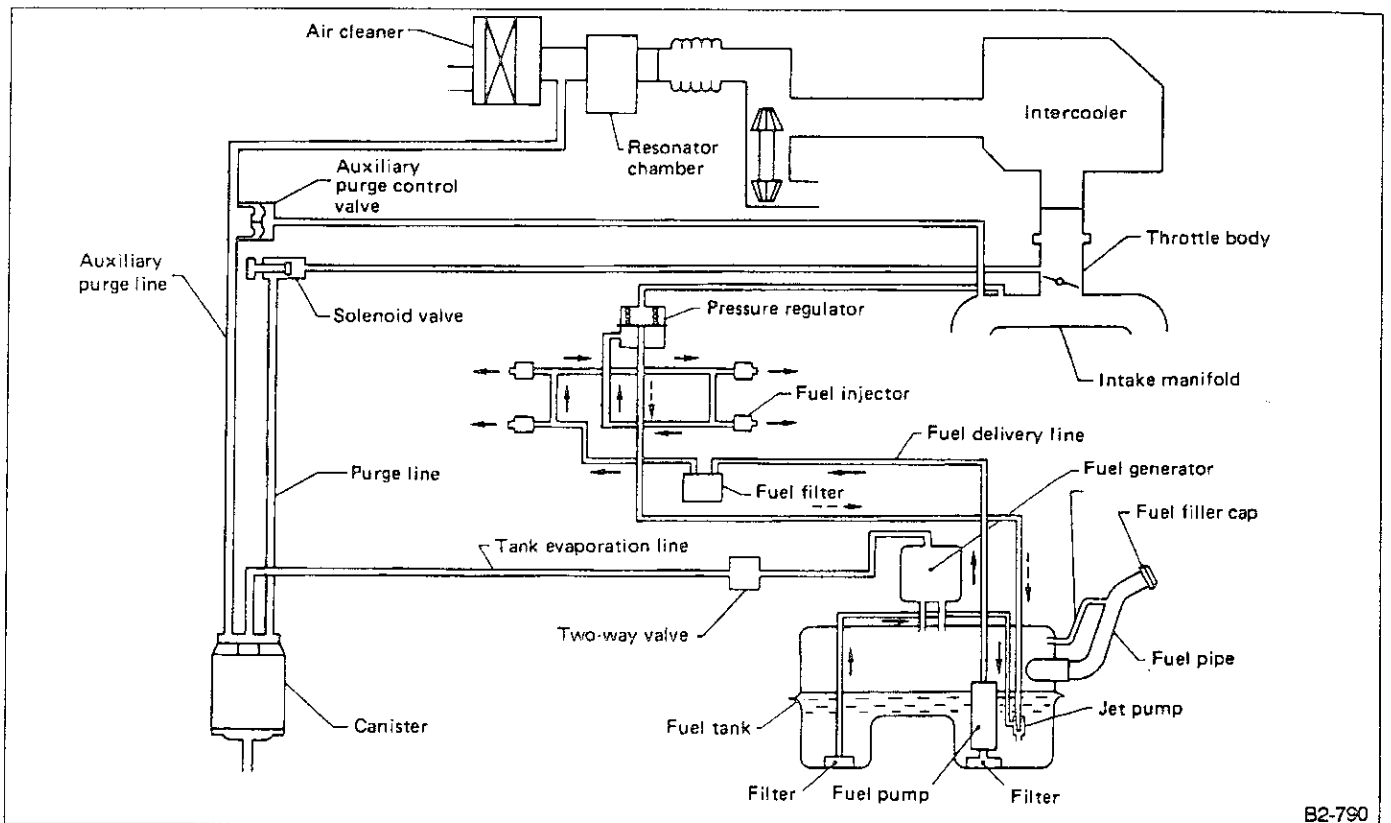
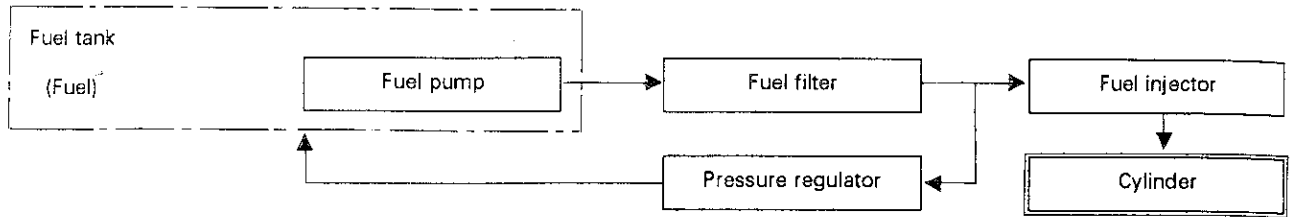


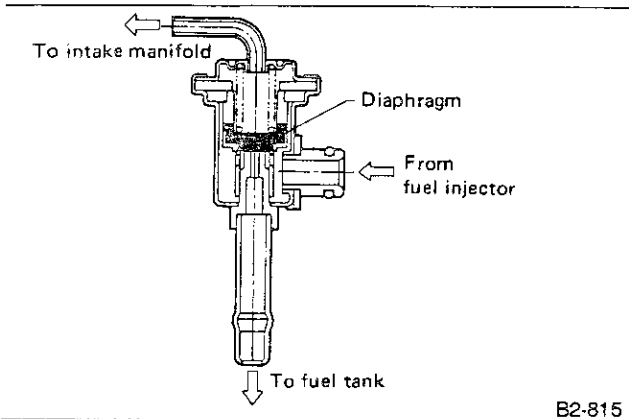
Fig. 5

B2-790

PRESSURE REGULATOR

The pressure regulator is divided into the fuel chamber and the spring chamber by the diaphragm as illustrated below. Fuel is fed to the fuel chamber through the fuel line connected with the injector. A difference in pressure between the fuel chamber and the spring chamber connected with the intake manifold causes the diaphragm to be pushed down, and fuel is fed back to the fuel tank through the return line.

By returning fuel so as to balance the above pressure difference and the spring force, the fuel pressure is kept at a constant level 250.1 kPa (2.55 kg/cm², 36.3 psi) constant the intake manifold pressure.



6

3. FUEL INJECTOR

The MPFI system employs a gallery type (side-feed type) fuel injector.

The gallery type fuel injector is installed in the fuel pipe to allow cooling of the injector by the fuel.

The features of this type of fuel injector are as follows:

- 1) High heat resistance
- 2) Low driving noise
- 3) Easy to service
- 4) Small size

The fuel injector injects fuel according to the valve open signal received from the ECU.

The nozzle is attached on the top of the fuel injector. The needle valve is lifted by the solenoid coil through the plunger on arrival of the valve open signal.

Since the injection opening, the lifted level of valve and the regulator-controlled fuel pressure are kept constant, the amount of fuel to be injected can be controlled only by the valve open signal from the ECU.

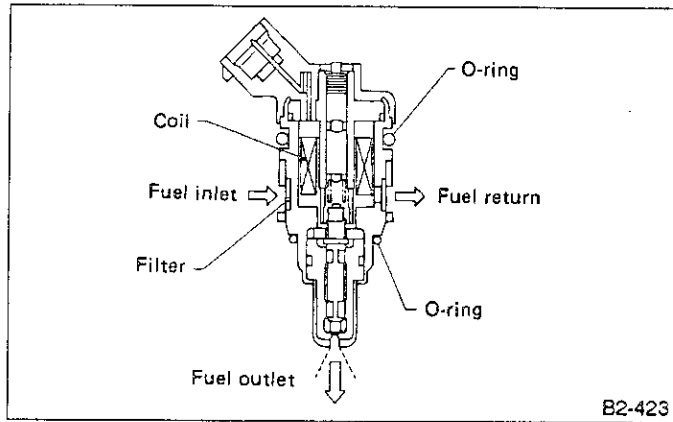


Fig. 7

4. Sensor and Switch

1. O₂ SENSOR

The O₂ sensor is used to sense oxygen concentration in the exhaust gas. If the fuel ratio is leaner than the stoichiometric ratio in the mixture (i.e. excessive amount of air), the exhaust gas contains more oxygen. To the contrary, if the fuel ratio is richer than the stoichiometric ratio, the exhaust gas contains hardly any oxygen. Therefore, examination of the oxygen concentration in exhaust gas makes it possible to show whether the air/fuel ratio is leaner or richer than the stoichiometric ratio. The O₂ sensor has a zirconia tube (ceramic) which generates voltage if there is a difference in oxygen concentration between the inside and outside of the tube. Platinum is coated on the inside and outside of the zirconia tube for the purpose of catalysis and electrode provision. The hexagon screw on the outside is grounded to the exhaust pipe, and the inside is connected to the ECU through the harness. A ceramic heater is employed to improve performance at low temperature.

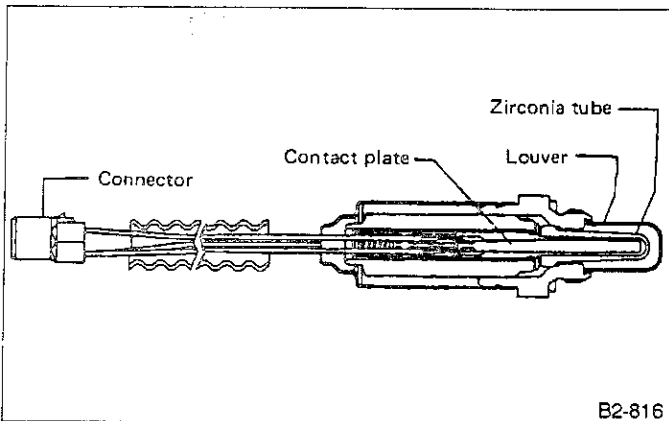


Fig. 8

When rich air-fuel mixture is burnt in the cylinder, the oxygen in the exhaust gases reacts almost completely through the catalytic action of the platinum coating on the surface of the zirconia tube. This results in a very large difference in the oxygen concentration between the inside and outside, and the electromotive force generated is large.

When a lean air-fuel mixture is burnt in the cylinder, oxygen remains in the exhaust gases even after the catalytic action, and this results in a small difference in the oxygen concentration. The electromotive force is very small.

The difference in oxygen concentration changes greatly in the vicinity of the optimum air-fuel ratio, and hence the change in the electromotive force is also large. By inputting this information into the MPFI control unit, the air-fuel ratio of the supplied mixture can be determined easily. The O₂ sensor does not generate much electromotive force when the temperature is low. The charac-

teristics of the electromotive force stabilize at temperature of approximately 300 to 400°C (572 to 752°F).

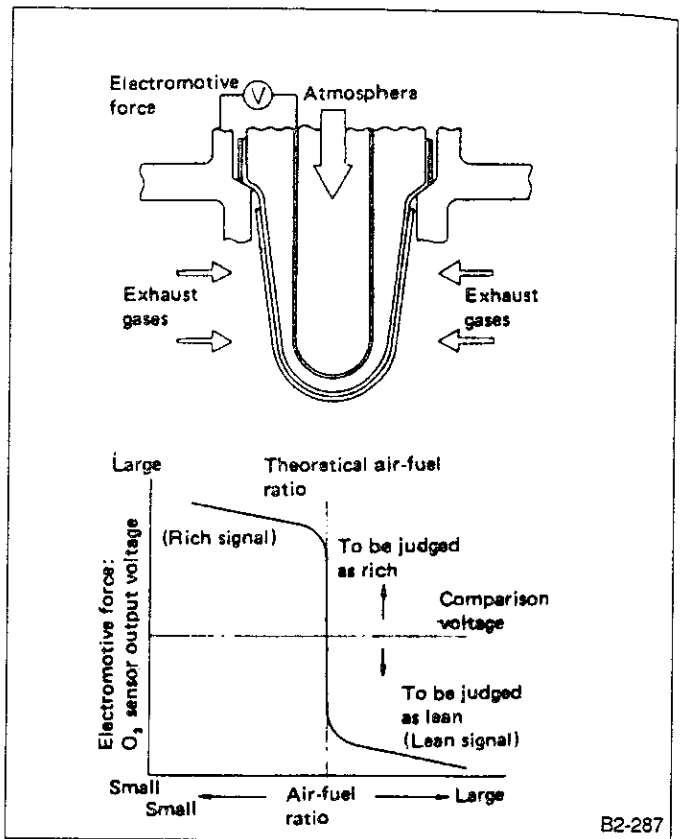


Fig. 9

2. WATER TEMPERATURE SENSOR

The water temperature sensor is located on the water pipe which is made of aluminum alloy. Its thermistor changes resistance with respect to temperature. A water temperature signal converted into resistance is transmitted to the ECU to control the amount of fuel injection, ignition timing, purge control solenoid valve, etc.

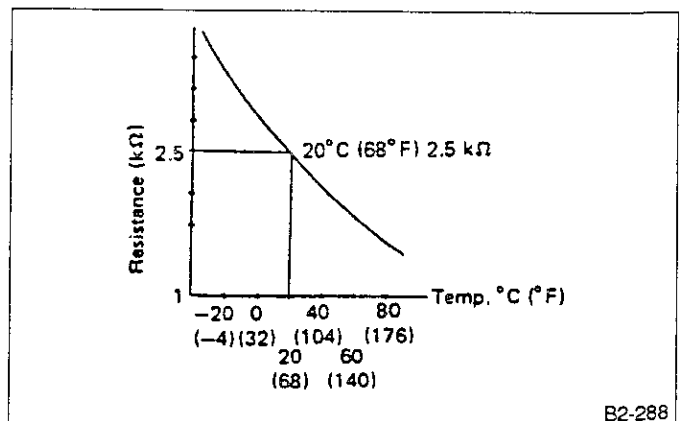
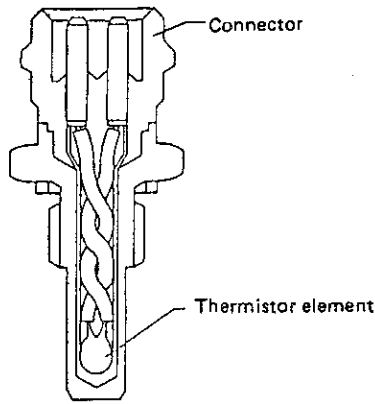


Fig. 10

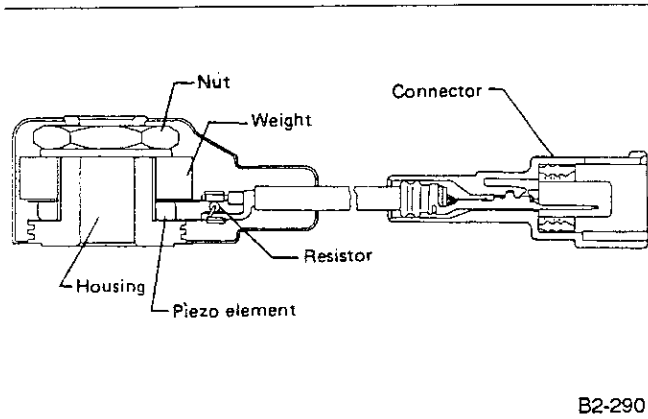


B2-289

7. 11

KNOCK SENSOR

The knock sensor is installed on the cylinder block, and senses knocking signals from each cylinder. This knock sensor is a piezo-electric type which converts knocking vibrations into electric signals. It consists of a piezo-electric element, weight, and case. When knocking occurs in the engine, the weight in the case moves causing the piezo-electric element to generate a voltage.

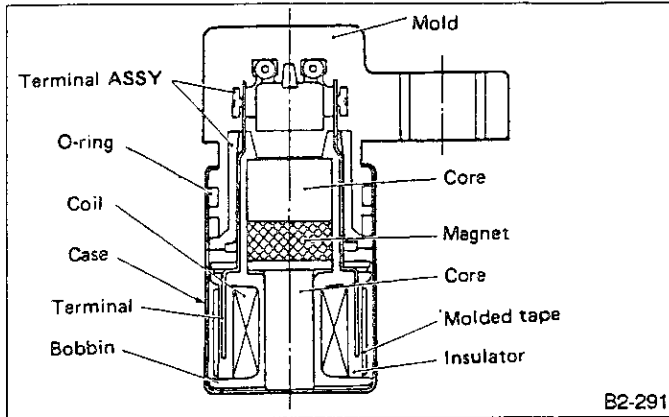


B2-290

g. 12

CRANK ANGLE SENSOR

The crank angle sensor is installed on the oil pump, located in the front center portion of the cylinder block, to detect the crank angle position. It is designed so that the ECU accurately reads the number of pulses which occur when protrusions provided at the perimeter of the crank sprocket (rotating together with the crankshaft) cross the crank angle sensor. The crank angle sensor is a molded type which consists of a magnet, pick-ups, coil, terminals, etc.

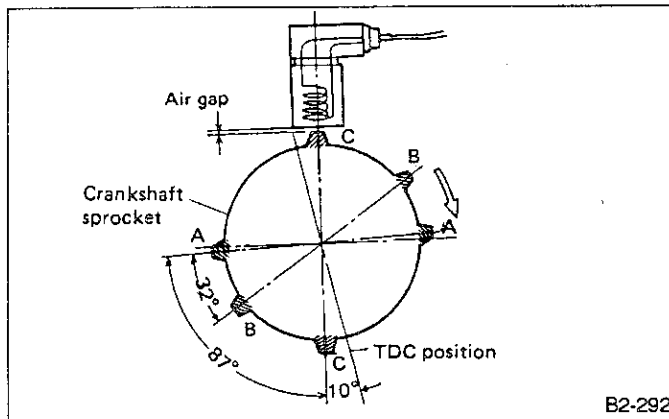


B2-291

Fig. 13

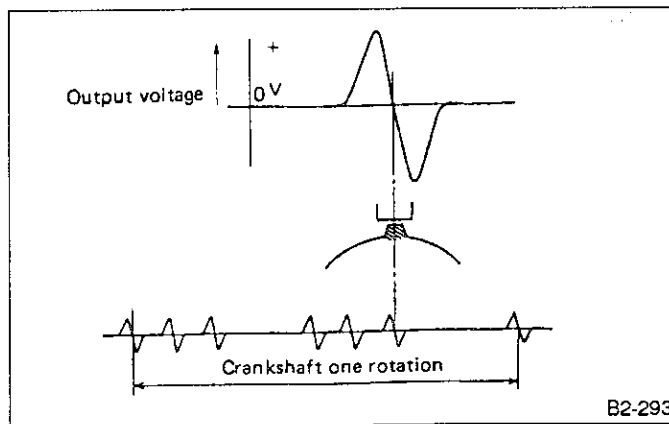
Function

The crank sprocket is provided with six protrusions. Crank rotation causes these protrusions to cross the crank angle sensor so that magnetic fluxes in the coil change with the change in air gap between the sensor pickup and the sprocket. The change in air gap induces an electromotive force which is transmitted to the ECU.



B2-292

Fig. 14



B2-293

Fig. 15

5. CAM ANGLE SENSOR

The cam angle sensor is located on the left-hand intake camshaft cap to detect the combustion cylinder at any one moment.

It is designed so that the ECU accurately reads the number of pulses which occur when protrusions provided on the back of the LH camshaft-drive sprocket cross the sensor.

Internal construction and the basic operating principle of the cam angle sensor are similar to those of the crank angle sensor. A total of seven protrusions (one each at two locations, two at one location and three at one location) are arranged in four equal parts of the sprocket, as shown below.

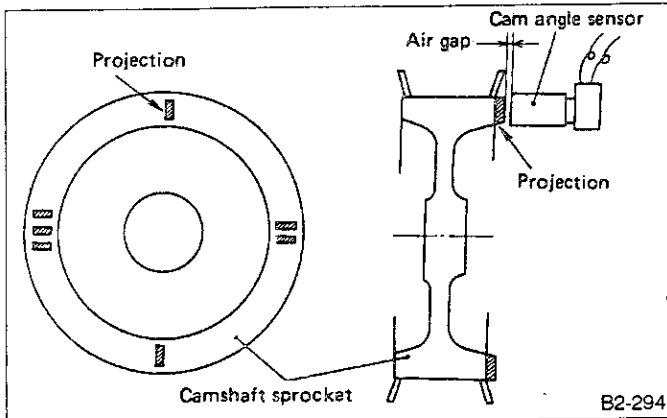


Fig. 16

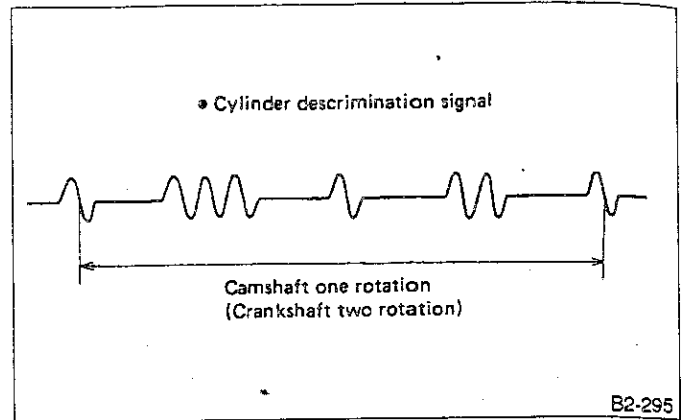


Fig. 17

6. VEHICLE SPEED SENSOR 2

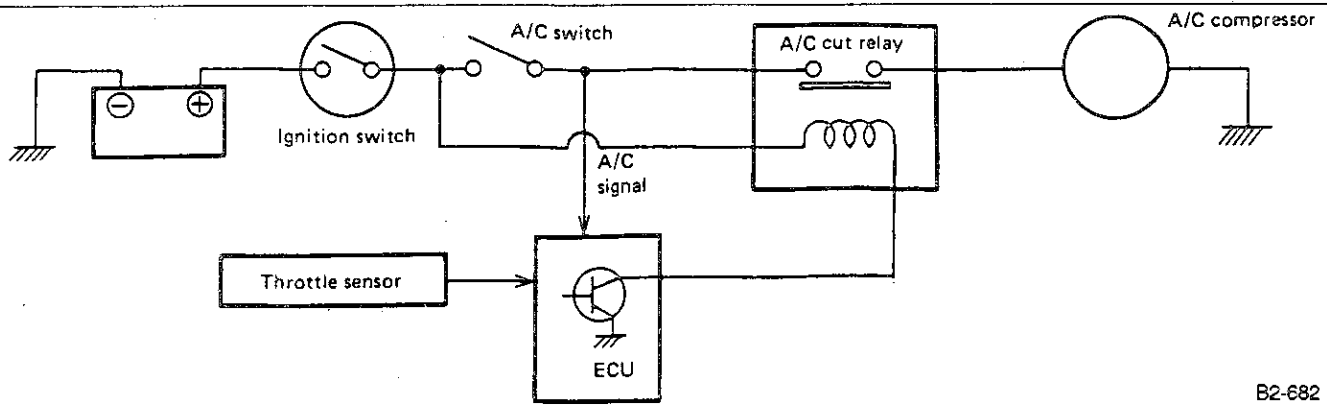
Vehicle speed sensor 2 is installed onto transmission case, the signal emitted from it is sent to the ECU and speedometer.

The inner shaft in vehicle speed sensor 2 is connected to speedometer shaft in transmission with plate. The pick-up signal is emitted by rotation of the shaft.

7. A/C (Air Conditioning) SWITCH AND RELAY

The A/C switch turns the A/C system on or off. The on-off operation of the switch is transmitted to the ECU. The A/C cut relay breaks the current flow to the compressor, through the use of an output signal from the ECU, for a certain period of time when a "full-

throttle" signal (emitted from the throttle sensor) enters the ECU while the compressor is operating. This prevents the degradation of acceleration performance and stabilizes driving performance. This cut relay is installed in the main fuse box located at the left side of the engine compartment.



B2-682

Fig. 18

8. PRESSURE SENSOR AND PRESSURE EXCHANGE SOLENOID VALVE

TURBO models have, in the inside of their engine compartment, a pressure sensor and a pressure exchange solenoid which switches pressure inlets so that the pressure sensor can detect both the atmospheric pressure and intake manifold pressure.

This selection of pressure inlet is performed by the pressure exchange solenoid valve according to the sig-

nal sent from the ECU. The output from the pressure sensor is entered into the ECU, which then sends out a signal for controlling the supercharging pressure to the wastegate control duty solenoid valve.

If the supercharging pressure exceeds the preset value, the fuel is cut by the ECU.

5. Control System

GENERAL

The ECU receives signals sent from various sensors and switches to judge the engine operating condition and emits output signals to provide the optimum control and/or functioning of various systems.

Major items governed by the ECU are as follow:

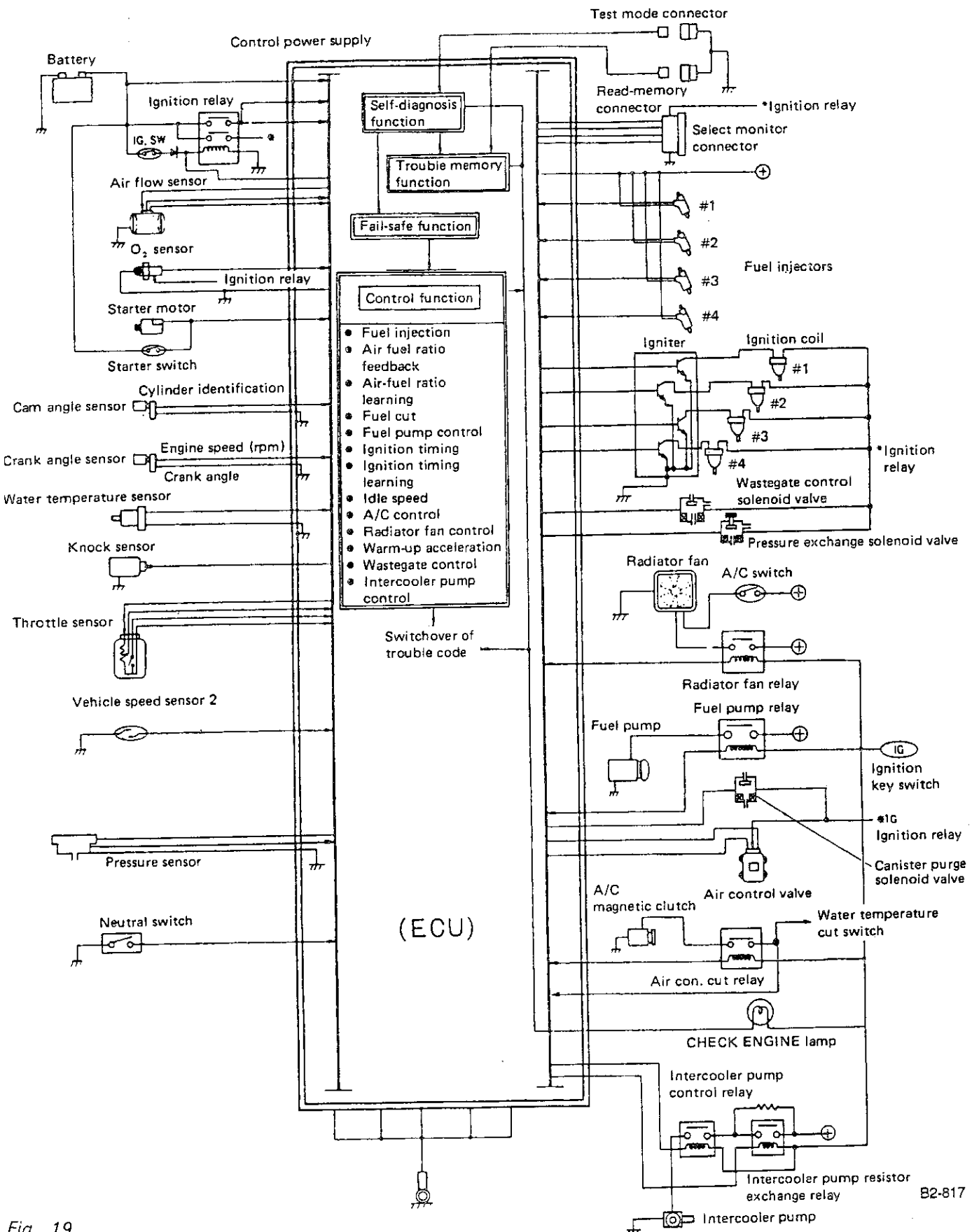
- Fuel injection control
- Ignition system control

- By-pass air control (Idle speed control)
- Canister purge control
- Radiator fan control
- Fuel pump control
- Air conditioner cut control
- Self-diagnosis function
- Fail-safe function
- Wastegate control (Supercharging pressure control)
- Intercooler pump control

INPUT AND OUTPUT SIGNALS

	Unit	Function
Input signal	Air flow sensor	Detects the amount of intake air.
	Throttle sensor	Detects the throttle position.
	Idle switch	Detects a fully-closed throttle.
	O ₂ sensor	Detects the density of O ₂ in exhaust gases.
	Crank angle sensor	Detects engine speed.
	Cam angle sensor	Detects the relative cylinder positions.
	Water temperature sensor	Detects the coolant temperature.
	Knock sensor	Detects engine knocking.
	Vehicle speed sensor 2	Detects vehicle speed.
	Ignition switch	Detects ignition switch operation.
	Starter switch	Detects the condition of engine cranking
	A/C switch	Detects the ON-OFF operation of the A/C switch.
	Neutral switch	Detects gear shift lever neutral position.
	Pressure sensor	Detects atmospheric pressure and intake manifold pressure.
Output signal	Fuel injector	Inject fuel.
	Ignition signal	Turns primary ignition current on or off.
	Fuel pump relay	Turns the fuel pump relay on or off.
	A/C control relay	Turns A/C control relay on or off.
	Radiator fan control relay	Turns radiator fan control relay on or off.
	By-pass air control solenoid valve	Adjusts the amount of by-pass air flowing through the throttle valve.
	Check engine light	Indicates trouble code.
	Purge control solenoid valve	Controls the amount of canister purge through the throttle body.
	Pressure exchange solenoid valve	Switches pressure detection line between atmospheric pressure and intake manifold pressure.
	Wastegate control duty solenoid valve	Controls the supercharging pressure.
	Intercooler pump control relay	Turns the intercooler pump relay on or off.
Intercooler pump resistor exchange relay	Changes intercooler pump current.	

INPUT AND OUTPUT SIGNAL DIAGRAM



B2-817

Fig. 19

4. FUEL INJECTION CONTROL

The ECU receives signals emitted from various sensors to control the amount of fuel injected and the fuel injection timing. Sequential fuel injection control is utilized over the entire engine operating range except during standing starts.

The amount of fuel injected by the injector valve is dependent upon the length of time it remains open. The optimum fuel injection timing is determined by transmitting a signal to the injector from the ECU according to varying engine operations. Feedback control is also accomplished by means of a learning control. As a result, the fuel injection control system is highly responsive and accurate in design and structure.

The sequential fuel injection system is designed so that fuel is injected at a specific time to provide maximum air intake efficiency for each cylinder. In other words, fuel injection is completed just before the intake valve begins to open.

1) Fuel injection characteristics

Fuel injection timing is basically expressed as indicated below:

- (1) During engine starts:
 - Duration of fuel injection
 - = Duration of fuel injection during engine starts
- (2) During normal operation:
 - Basic duration of fuel injection x correction factor
 - + voltage correction time
 - Basic duration of fuel injection The basic length of time fuel is injected. This is determined by two factors—the amount of intake air detected by the air flow sensor and the engine speed (rpm) monitored by the crank angle sensor.
 - Duration of fuel injection during engine starts Determined according to the engine coolant temperature detected by a signal emitted from the water temperature sensor to improve starting ability.
 - Voltage correction time Compensates for the fuel injector's time lag affected by the battery voltage.

2) Correction coefficients

Correction coefficients are used to correct the basic duration of fuel injection so that the air-fuel ratio meets the requirements of varying engine operations.

These correction coefficients are classified as follows:

(1) Air-fuel ratio coefficient:

Allotted to provide the optimum air-fuel ratio in relation to engine speed and the basic amount of fuel injected.

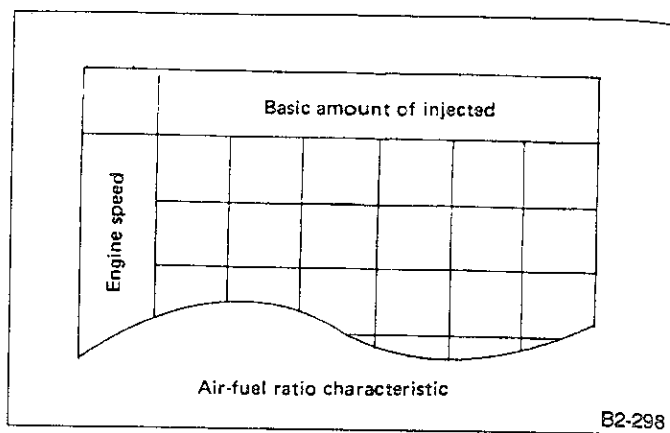


Fig. 20

(2) Start increment coefficient:

Increases the amount of fuel injected only when cranking the engine, which improves starting ability.

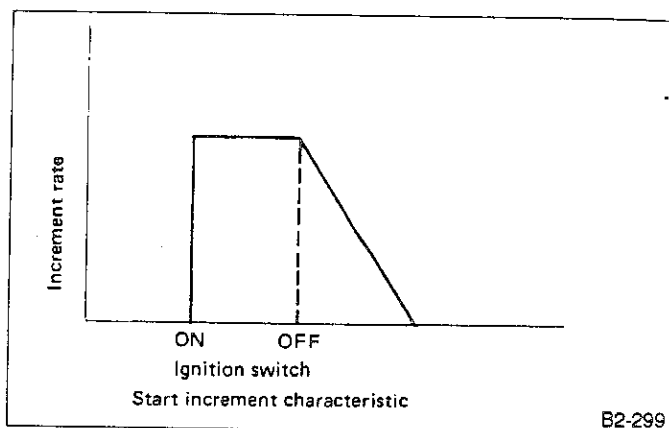


Fig. 21

(3) Water temperature increment coefficient:

Used to increase the amount of fuel injected in relation to a signal emitted from the water temperature sensor for easier starting of a cold engine. The lower the water temperature, the greater the increment rate.

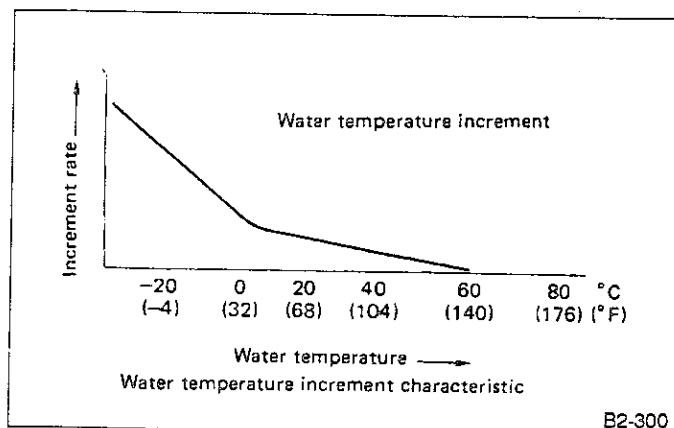


Fig. 22

(4) After-start increment coefficient:
Increases the amount of fuel injected for a certain period of time immediately after the engine starts to stabilize engine operation.

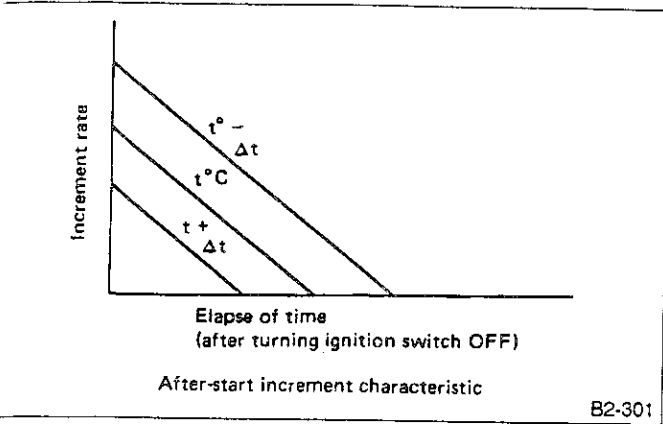


Fig. 23

(5) Full increment coefficient:
Increases the amount of fuel injected by a signal emitted from the throttle sensor in relation to a signal emitted from the air flow sensor.

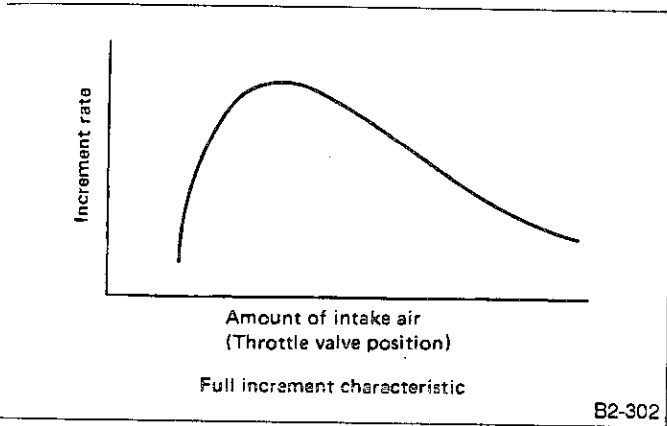


Fig. 24

(6) Acceleration increment coefficient:
Compensates for time lags of air flow measurement and/or fuel injection during acceleration to provide quick response.

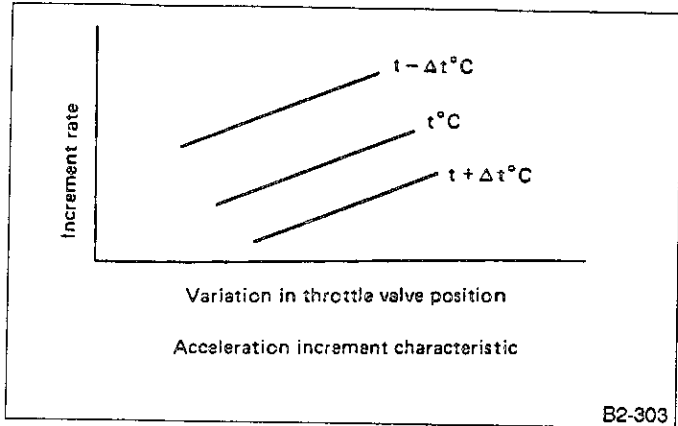
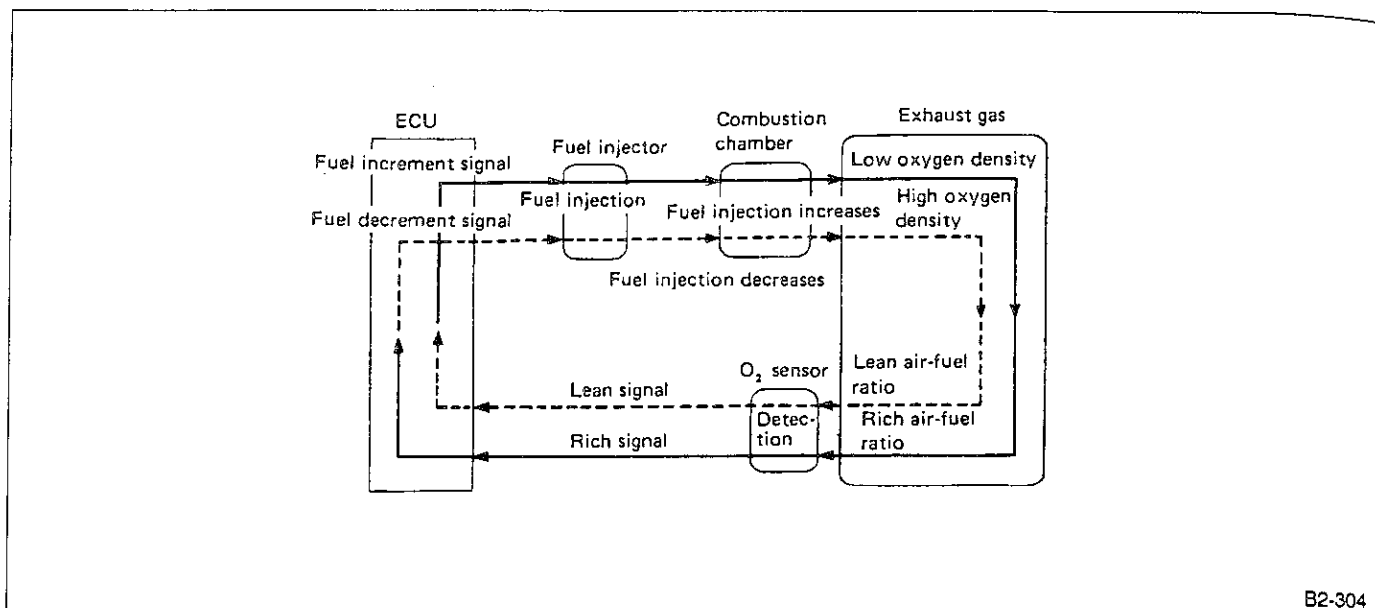


Fig. 25

3) Air-fuel ratio feedback coefficient "alpha"

This feedback coefficient utilizes the O_2 sensor's electromotive force (voltage) as a signal to be entered into the ECU. When low voltage is entered, the ECU judges it as a lean mixture, and when high voltage is entered, it is judged as a rich mixture. In other words, when the air-fuel ratio is richer than the theoretical air-fuel ratio, the amount of fuel injected is decreased. When it is leaner, the amount of fuel injected is increased. In this way, the air-fuel ratio is compensated so that it comes as close to the theoretical air-fuel ratio as possible on which the three-way catalyst acts most effectively. (CO, HC and NOx are also reduced when the air-fuel ratio is close to theoretical air-fuel ratio.)



B2-304

Fig. 26

4) Learning control system

In a conventional air-fuel feedback control system, the basic amount of fuel injected (according to engine speed and various loads) is stored in the memory. After the ECU receives a signal emitted from the O₂ sensor, the basic amount of fuel injected is corrected so that it is close to the theoretical air-fuel ratio. This means that the greater the air-fuel ratio is corrected, the lesser the control accuracy.

In Subaru engines, however, an air-fuel ratio learning control system constantly memorizes the amount of correction required in relation to the basic amount of fuel to be injected (the basic amount of fuel injected is determined after several cycles of fuel injection), so that the correction affected by feedback control is minimized. Thus, quick response and accurate control of variations in air-fuel ratio, sensors' and actuators' characteristics during operation, as well as in the air-fuel ratio with the time of engine operation, are achieved. In addition, accurate control contributes much to stability of exhaust gases and driving performance.

5. IGNITION SYSTEM CONTROL

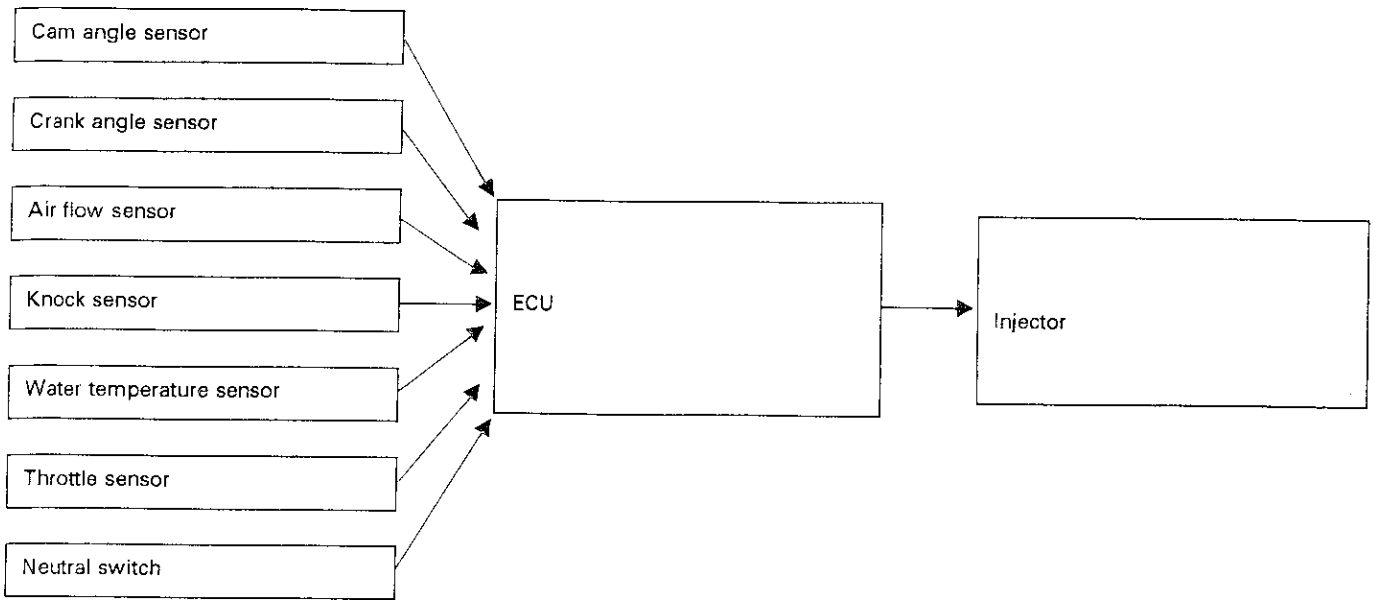
The ECU receives signals emitted from the air flow sensor, water temperature sensor, crank angle sensor, cam angle sensor, knock sensor, etc., to judge the operating condition of the engine. It then selects the optimum ignition timing stored in the memory and immediately transmits a primary current OFF signal to the igniter to control the ignition timing.

While the ECU receives signals emitted from the knock sensor, it is controlled so that advanced ignition timing is maintained immediately before engine knock occurs. This system control type features a quick-to-response learning control method by which data stored in the ECU memory is processed in comparison with information emitted from various sensors and switches.

Thus, the ECU constantly provides the optimum ignition timing in relation to output, fuel consumption, exhaust gas, etc., according to various engine operating conditions, the octane rating of the fuel used, etc.

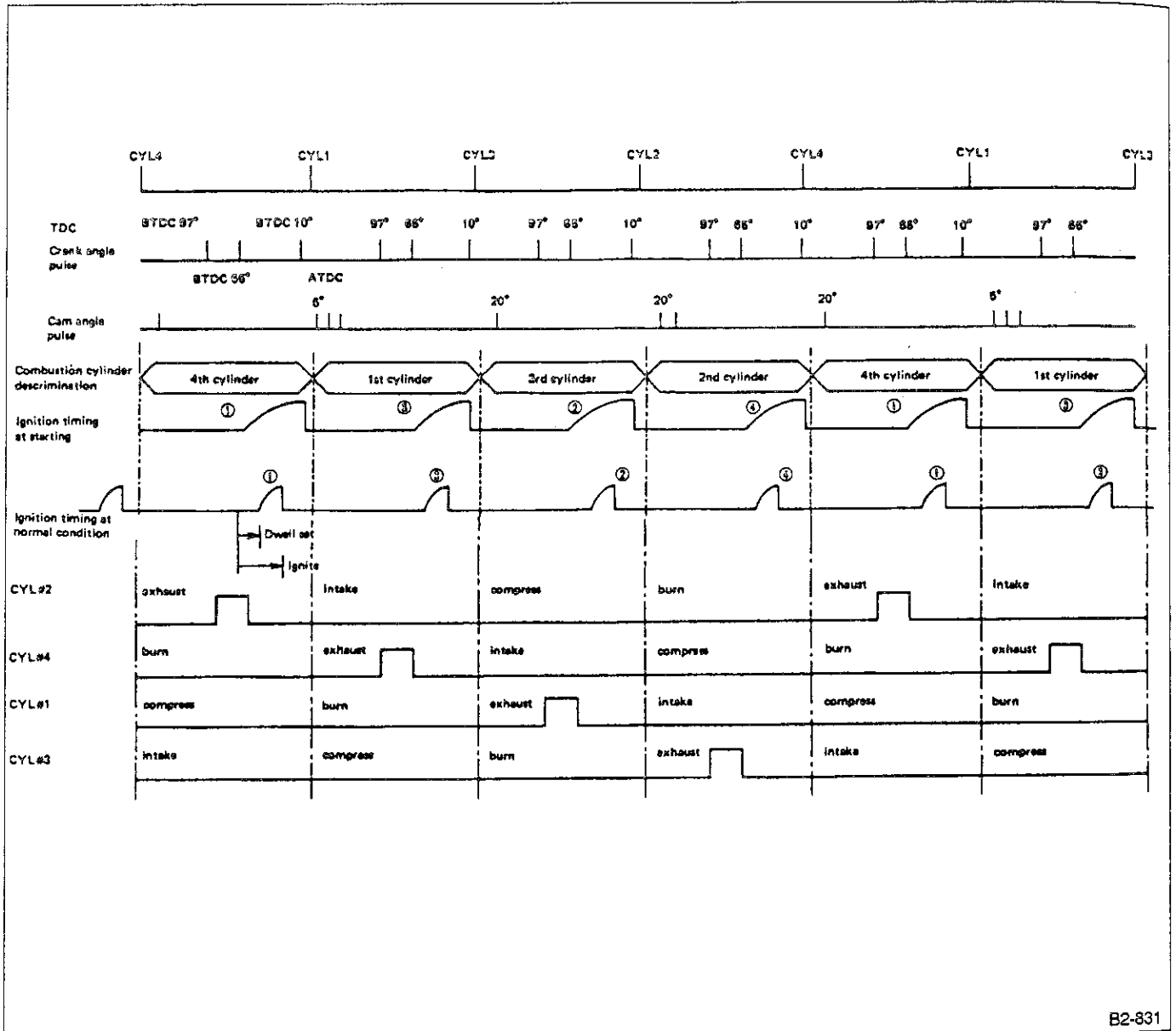
Four ignition coils are directly mounted to the spark plugs of the respective cylinders.

This eliminates the distributor and high tension cord and achieves maintenance-free operation.



● Ignition control under normal engine conditions
 Between the 97° signal and the 65° signal, the ECU measures the engine revolutions, and by using this data it decides the dwell set timing and ignition timing according to the engine condition.

● Ignition control under starting conditions
 Engine revolutions fluctuate at the starting condition, so the ECU cannot control the ignition timing. When such a condition exists, ignition timing is fixed at 10° BTDC by using the 10° signal.



B2-831

Fig. 27

6. BY-PASS AIR CONTROL (IDLE SPEED CONTROL)

The ECU activates the by-pass air control valve in advance to control the amount of by-pass air flowing through the throttle valve in relation to signals emitted from the crank angle sensor, cam angle sensor, water temperature sensor and A/C switch, so that the proper idle speed specified for each engine load is achieved. The by-pass air control valve utilizes a duty solenoid design so that the amount of valve "lift" is determined by a certain operating frequency. For this reason, the by-pass air flow is regulated by controlling the duty

ratio. The relationship between the duty ratio, valve lift and by-pass air flow is as follows:

Duty ratio (high) → Increases valve lift and by-pass air flow.

By-pass air control features the following advantages:

1. Compensation for engine speed under A/C (air conditioning) system and electrical loads.
2. Increase in idle speed during early stage of warm-up period.
3. A dashpot function during the time the throttle valve is quickly closed.
4. Prevention of engine speed variations over time.

Diagram

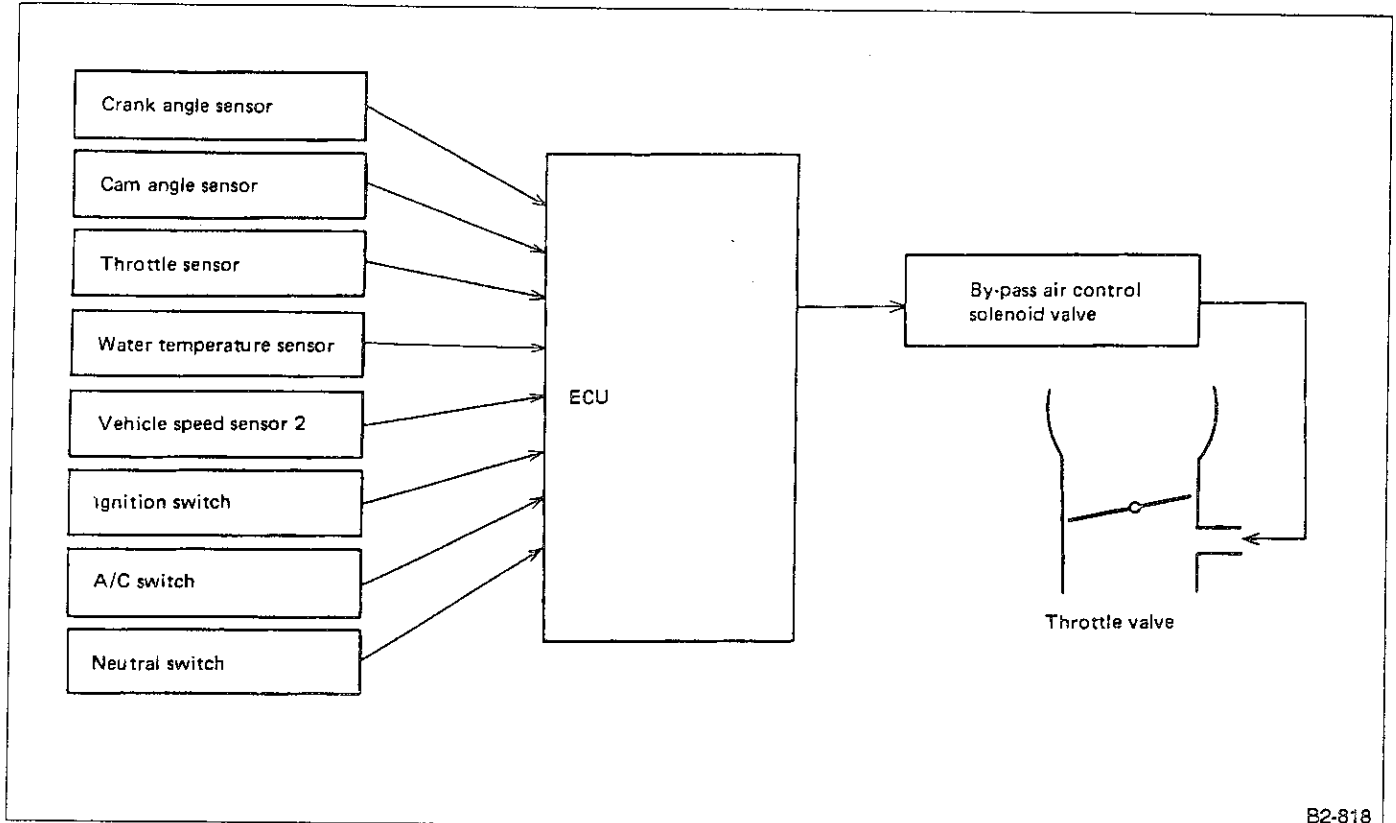


Fig. 28

B2-818

7. CANISTER PURGE CONTROL

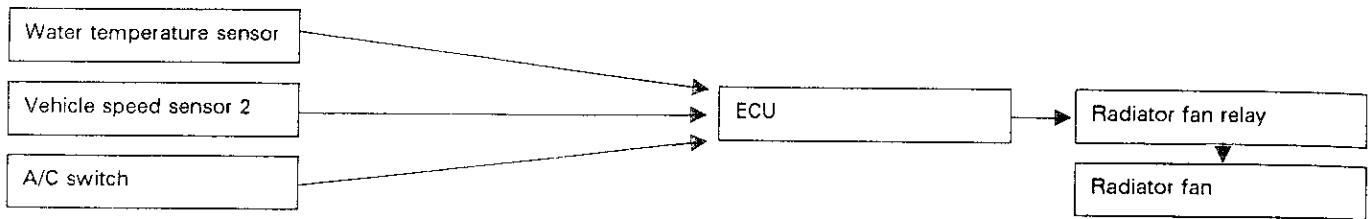
The ECU receives signals emitted from the water temperature sensor, vehicle speed sensor and crank angle sensor to control the purge control solenoid.

Canister purge takes place during operation of the vehicle except under certain conditions (during idle, etc.). The purge line is connected to the throttle chamber to purge fuel evaporation gas from the canister according to the amount of intake air.

8. RADIATOR FAN CONTROL

The ON-OFF control of the radiator fan (for models which are not equipped with an air conditioning system) is governed by the ECU which receives signals

sent from the water temperature sensor and vehicle speed sensor. On models which are equipped with an air conditioning system, the ECU receives signals sent from the water temperature sensor, vehicle speed sensor and A/C switch. These signals simultaneously turn ON or OFF the main radiator fan and A/C sub fan as well as setting them at "HI" or "LO" speed.



9. FUEL PUMP CONTROL

The ECU receives a signal emitted from the crank angle sensor and turns the fuel pump relay ON or OFF to control fuel pump operation. To improve safety, the fuel

pump will stop if the engine stalls with the ignition switch ON.

Ignition switch ON	Fuel pump relay	Fuel pump
A certain period of time (after ignition switch is turned ON)	ON	Operates
While cranking the engine	ON	Operates
While engine is operating	ON	Operates
When engine stops	OFF	Does not operate



10. A/C CUT CONTROL

When the ECU receives a "full-open" signal emitted from the throttle sensor while the air conditioning system is operating, the A/C cut relay turns off for a certain

period of time to stop the compressor. This prevents degradation of output during acceleration and stabilizes driveability.

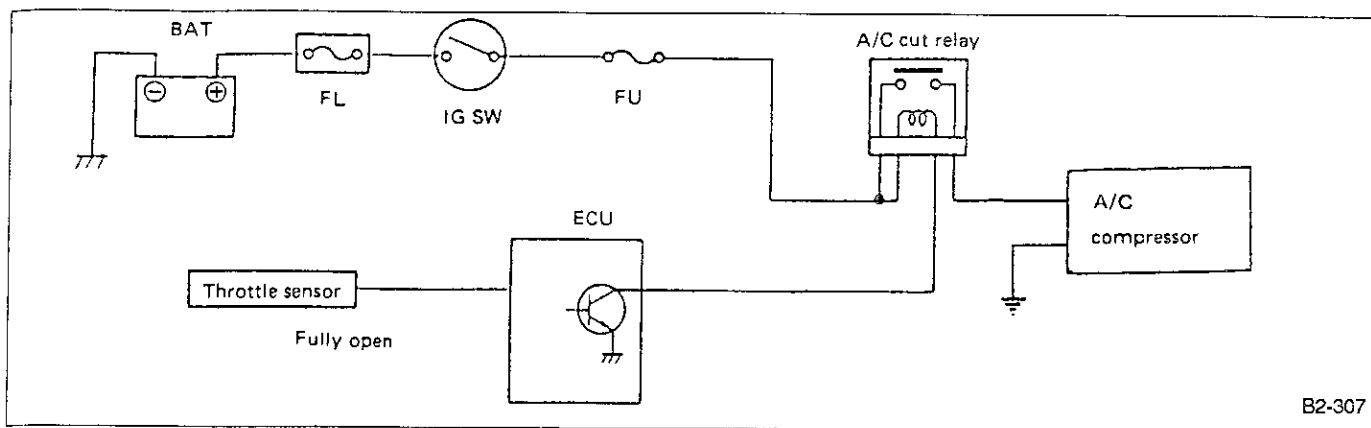
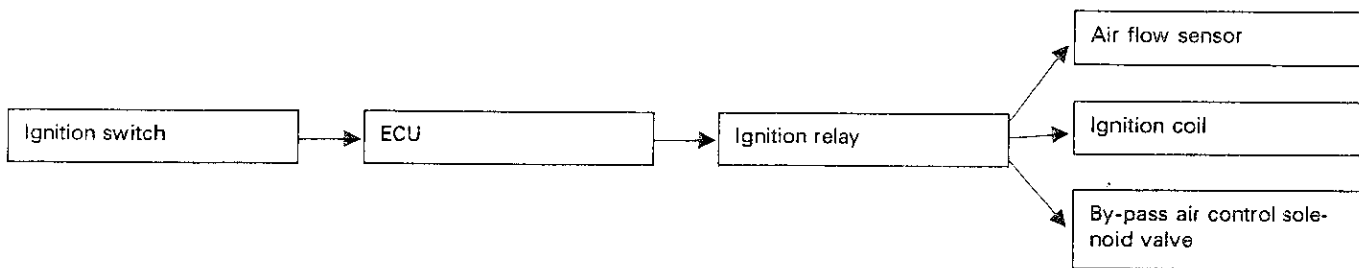


Fig. 29

11. POWER SUPPLY CONTROL

When the ECU receives an ON signal emitted from the ignition switch, current flows through the ignition relay. This turns the ignition relay ON so that power is supplied to the ignition coil, air flow sensor, by-pass air control solenoid valve, etc.

Power to the above parts except the fuel injectors is turned off five seconds after the ECU receives an OFF signal from the ignition switch. The fuel injectors stop fuel injection immediately after the ignition switch is turned OFF because the injection signal is cut off.



12. WASTEGATE CONTROL (SUPERCHARGING PRESSURE CONTROL)

The ECU computes the objective supercharging pressure according to the signals sent from the crank angle sensor, air flow sensor, throttle sensor, pressure sensor, and water temperature sensor. The ECU then sends a signal to the duty solenoid valve so as to attain

the computed objective supercharging pressure. The duty solenoid valve, according to the signal from the ECU, leaks out the pressure applied to the wastegate valve controller so that the supercharging pressure at which the wastegate valve opens reaches the objective level. By this method, engine performance in acceleration or in high altitude is compensated.

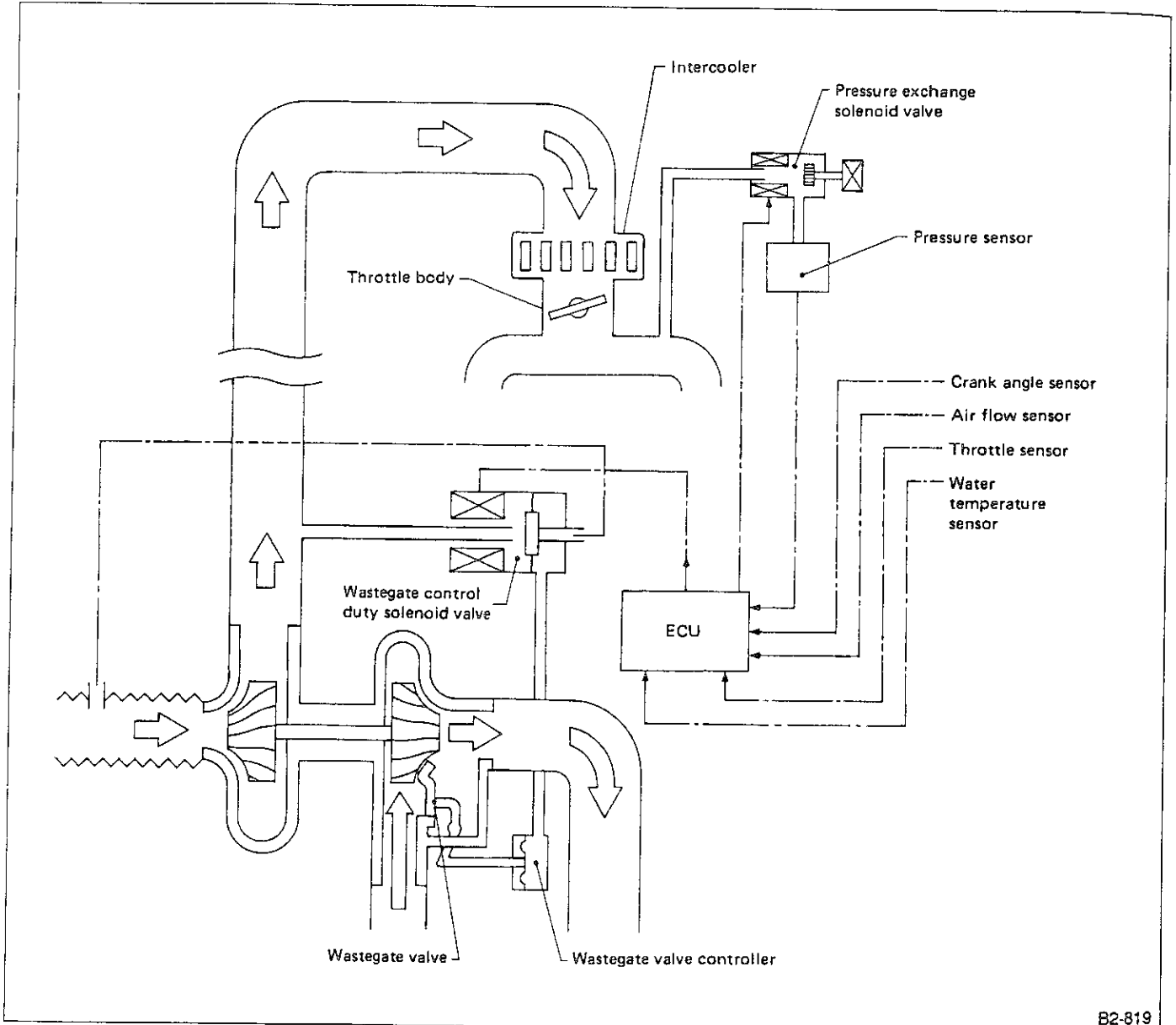


Fig. 30

B2-819

Self-diagnosis System

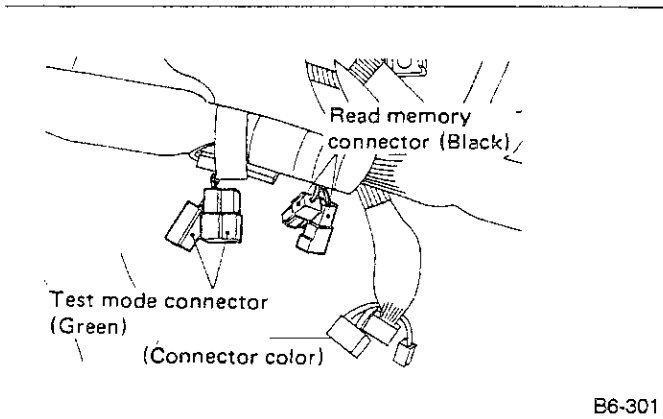
GENERAL

The self-diagnosis system detects and indicates a fault in various inputs and outputs of the complex electronic control. The warning light (CHECK ENGINE light) on the instrument panel indicates occurrence of a fault or trouble, and also indicates a trouble code.

Further, against such a failure or sensors as may disable the drive, the fail-safe function is provided to ensure the minimal driveability.

FUNCTION OF SELF-DIAGNOSIS

The self-diagnosis function has four modes: U-check mode, Read memory mode, D-check mode and Clear memory mode. Two connectors (Read memory and Test mode) and one light (CHECK ENGINE light) are used. The connectors are for mode selection and the light monitors the type of problem.



Relationship between modes and connectors

Mode	Engine	Read memory connector	Test mode connector
U-check	Ignition ON	DISCONNECT	DISCONNECT
Read memory	Ignition ON	CONNECT	DISCONNECT
D-check	Ignition ON (Engine ON)	DISCONNECT	CONNECT
Clear memory	Ignition ON (Engine ON)	CONNECT	CONNECT

U-check mode

The U-check is a user-oriented mode in which only the MPFI components necessary for start-up and drive are diagnosed. On occurrence of a fault, the warning light (CHECK ENGINE light) is lighted to indicate to the user that the dealer's inspection is necessary. The diagnosis of other parts which do not give significant adverse effect to start-up and drive are excluded from this mode in order to avoid unnecessary uneasiness to be taken by the user.

Read memory mode

This mode is used by the dealer to read past problems (even when the vehicle's monitor lights are off). It is most effective in detecting poor contact or loose connections of connectors, harnesses, etc.

D-check mode

This mode is used by the dealer to check the entire MPFI system and detect faulty parts.

Clear memory mode

This mode is used by the dealer to clear the trouble code from the memory after the affected part is repaired.

3. BASIC OPERATION OF SELF-DIAGNOSIS SYSTEM

• No TROUBLE

Mode	Read memory connector	Test mode connector	Condition	CHECK ENGINE light
U-check	x	x	Ignition switch ON (Engine OFF)	ON
			Engine ON	OFF
Read memory	○	x	Ignition switch ON (Engine OFF)	Blink
			Engine ON	
D-check	x	○	Ignition switch ON (Engine OFF)	ON
			Engine ON	OFF → Blink*
Clear memory	○	○	Ignition switch ON (Engine OFF)	ON
			Engine ON	OFF → Blink*

• TROUBLE

Mode	Read memory connector	Test mode connector	Condition	CHECK ENGINE light
U-check	x	x	Ignition switch ON	ON
Read memory	○	x	Ignition switch ON (Engine OFF)	Trouble code (Memory)
			Engine ON	ON
D-check	x	○	Engine ON	Trouble code**
Clear memory	○	○	Engine ON	Trouble code**

* When the engine operates at a speed greater than 2,000 rpm for more than 40 seconds, the check engine light blinks. However, when all check items check out "O.K.", even before the 40 seconds is

reached, the check engine light blinks.
** When the engine operates at a speed greater than 2,000 rpm for more than 40 seconds, a trouble code is emitted.

4. FAIL-SAFE FUNCTION

For the part which has been judged faulty in the self-diagnosis, the ECU generates the associated pseudo signal (only when convertible to electric signal) and car-

ries out the computational processing. In this fashion, the fail-safe function is performed.

5. TROUBLE CODES AND FAIL-SAFE OPERATION

Trouble code	Item	Contents of diagnosis	Fail-safe operation
11	Crank angle sensor	No signal entered from crank angle sensor, but signal (corresponding to at least one rotation of crank) entered from cam angle sensor.	—
12	Starter switch	Abnormal signal emitted from ignition switch.	Turns starter switch signal ON or OFF according to engine speed.
13	Cam angle sensor	No signal entered from cam angle sensor, but signal (corresponding to at least two rotations of cam) entered from crank angle sensor.	—
14	Injector #1	Fuel injector inoperative. (Abnormal signal emitted from monitor circuit.)	—
15	Injector #2		—
16	Injector #3		—
17	Injector #4		—
21	Water temperature sensor	Abnormal signal emitted from water temperature sensor.	Adjusts water to a specific temperature. Maintains radiator fan "ON" to prevent overheating.
22	Knock sensor	Abnormal voltage produced in knock sensor monitor circuit.	Sets in regular fuel map and retards ignition timing by 5°.
23	Air flow sensor	Abnormal voltage input entered from air flow sensor.	Controls the amount of fuel (injected) in relation to engine speed and throttle sensor position.
24	By-pass air control solenoid valve	Solenoid valve inoperative. (Abnormal signal produced in monitor circuit.)	Prevents abnormal engine speed using "fuel cut" in relation to engine speed, vehicle speed and throttle sensor position.
31	Throttle sensor	Abnormal voltage input entered from throttle sensor.	Sets throttle sensor's voltage output to a fixed value.
32	O ₂ sensor	O ₂ sensor inoperative.	—
33	Vehicle speed sensor	Abnormal voltage input entered from vehicle speed sensor.	Sets vehicle speed signal to a fixed value.
35	Purge control solenoid valve	Solenoid valve inoperative.	—
42	Idle switch	Abnormal voltage input entered from idle switch.	Judges ON or OFF operation according to throttle sensor's signal.
44	Wastegate control duty solenoid valve	Duty solenoid valve inoperative.	Cuts fuel off when engine is operating at full throttle under heavy loads.
45	Pressure sensor and pressure exchange solenoid valve	Faulty sensor or pressure exchange solenoid valve inoperative.	Cuts fuel off when engine is operating at full throttle under heavy loads.
49	Air flow sensor	Use of improper air flow sensor.	—
51	Neutral switch	Abnormal signal entered from neutral switch.	—

7. Turbocharger System

A: GENERAL

The turbocharger system combines a water-cooled turbocharger, intercooler, and an MPFI (multi-point fuel injection) control unit for supercharged pressure control. It is designed for ease of driving over a normal range of low to high speeds while maintaining high performance. This supercharged pressure control is sensitive to barometric pressure changes, which ensures consistent performance while operating at different altitudes.

• Operation

(1) Air is drawn from the resonator, filtered through the air cleaner, and sent to the turbocharger where it is compressed. The compressed air is then cooled in the water cooled intercooler, sent through the throttle valve to the intake manifold and distributed to each cylinder.

(2) Air remaining upstream of the throttle valve must be by-passed quickly to avoid rapid pressure change caused by a sudden closure of the throttle valve. Accordingly, the air by-pass valve is opened when the intake manifold vacuum increases suddenly, so that the supercharged air can be by-passed upstream of the turbocharger. By using this system, air noises associated with deceleration are reduced.

(3) The supercharging pressure control system consists of a pressure sensor, MPFI control unit, wastegate control solenoid valve, wastegate controller, and wastegate valve. The pressure sensor normally monitors intake manifold air pressure and sends an air pressure signal to the MPFI control unit. Consequently, appropriate supercharged pressure is always maintained even when driving from lowlands to uplands and through various changes in altitude.

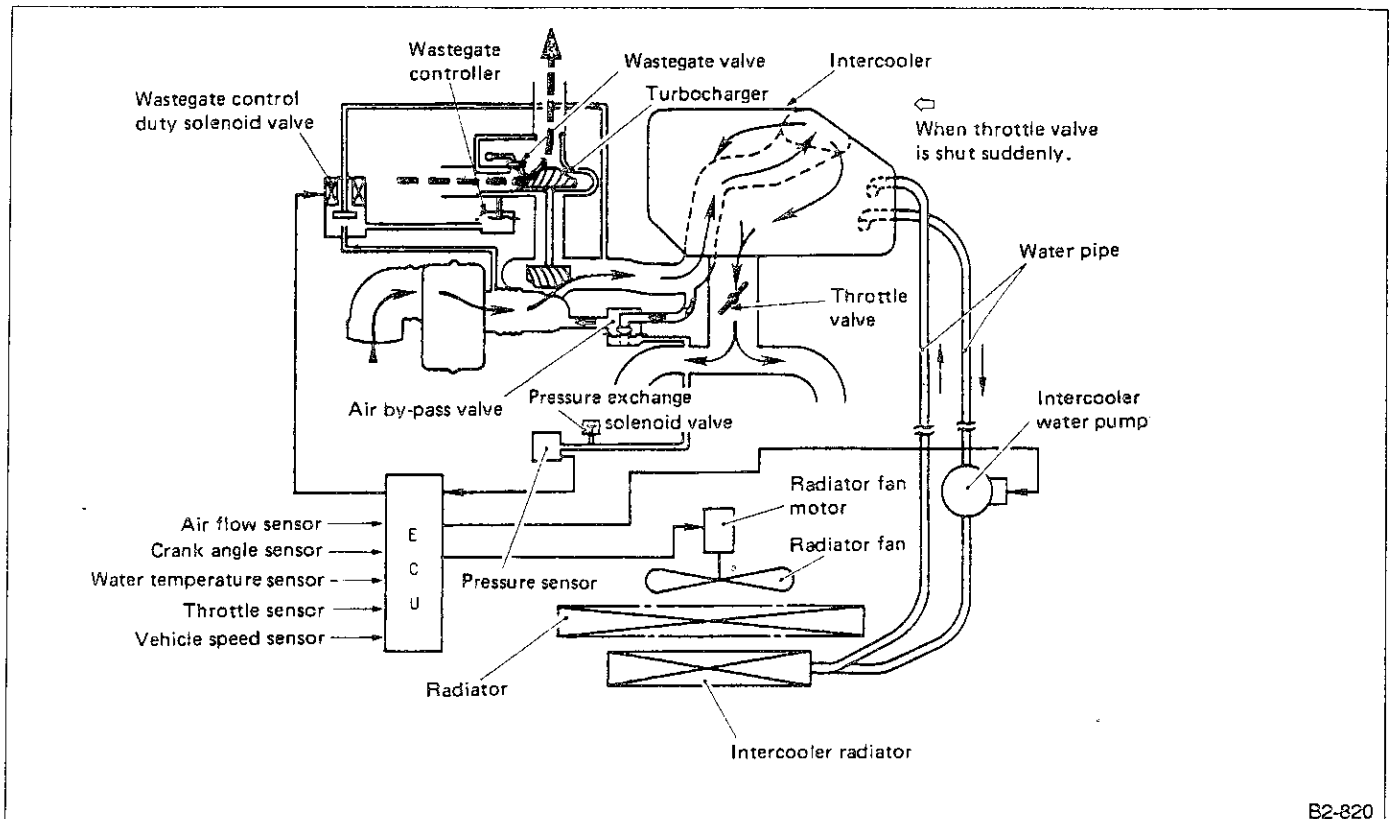


Fig. 32

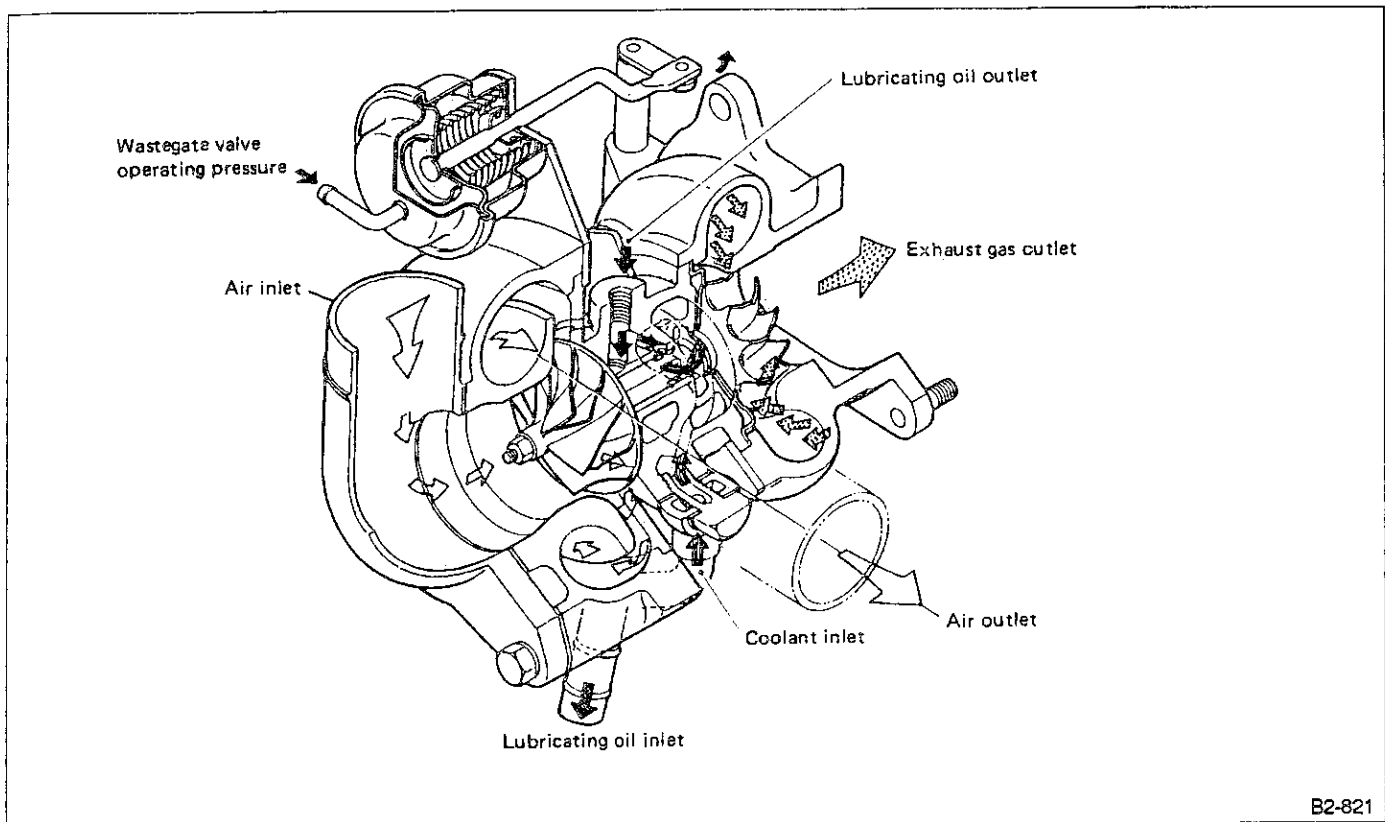
B2-820

B: TURBOCHARGER

heat-resistant casting. The compressor is a thin wall aluminum alloy casting. The bearing section uses a full-floating metal system.

1. GENERAL

The turbocharger is water-cooled, and utilizes a wastegate valve to normalize supercharged pressure. The turbine is constructed of a lightweight, thin walled, and



B2-821

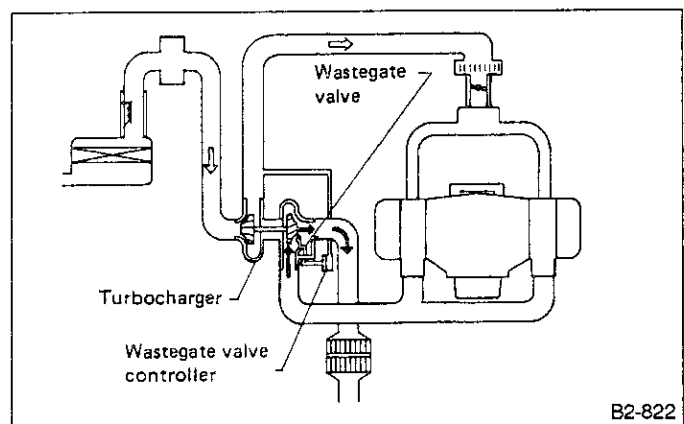
Fig. 33

2. REGULATION OF SUPERCHARGING PRESSURE

1) Basic function of the wastegate valve

As the engine speed increases with the opening of the throttle valve, the amount of exhaust gas increases. This leads to increase in the rotational speed of turbine (approx. 20,000 to 150,000 rpm), the supercharging pressure and the output.

However, excessive supercharging pressure may cause occurrence of the knocking and heavier thermal load on such a part as piston. In the worst case, the engine may be damaged or broken. To prevent this, the wastegate valve and its controller are equipped. By sensing the supercharging pressure, the wastegate valve restricts it below a predetermined level.



B2-822

Fig. 34

While the supercharging pressure is lower than the predetermined level, the wastegate valve is closed so that all the exhaust gas is carried through the turbine.

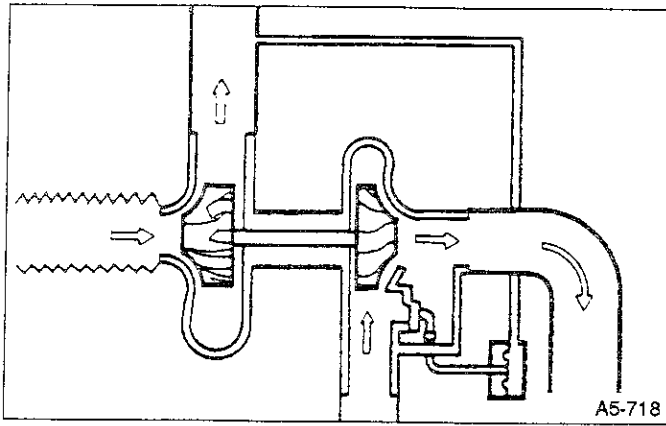


Fig. 35

When it reaches the predetermined level, the wastegate controller lets the supercharging pressure to press the diaphragm, causing the linked wastegate valve to open. With the wastegate-valve opened, a part of the exhaust gas is allowed to flow into the exhaust gas pipe by bypassing the turbine.

This decreases the turbine rotating energy to keep the supercharging pressure constant.

It means $P_2 - P_1 = \text{constant}$

P_1 : Atmospheric pressure

P_2 : Supercharging pressure

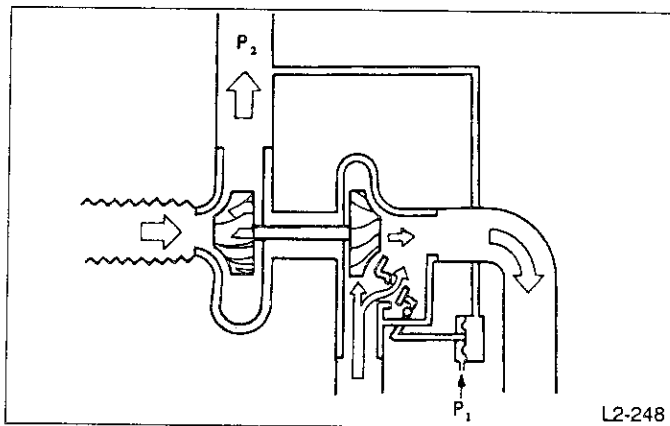


Fig. 36

2) Concept of the wastegate valve control

The higher the altitude, the lower the atmospheric pressure (P_1) and supercharging pressure (P_2). The duty solenoid valve acts as a control to maintain maximum supercharging pressure (P_2) under absolute pressure.

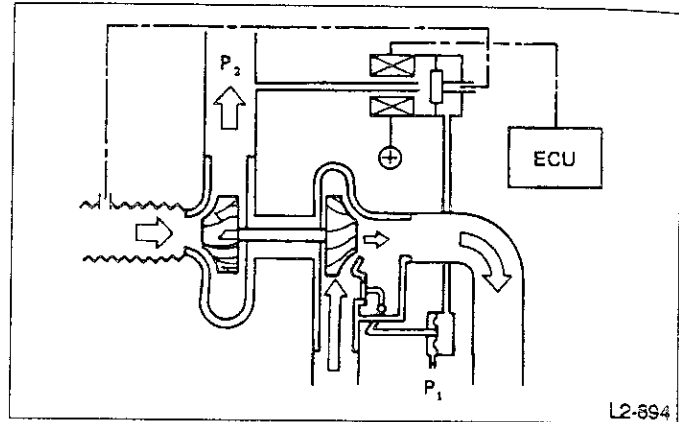


Fig. 37

Max. $P_2 = \text{const}$ (Absolute pressure 174.6 kPa (1,310 mmHg, 51.57 inHg))

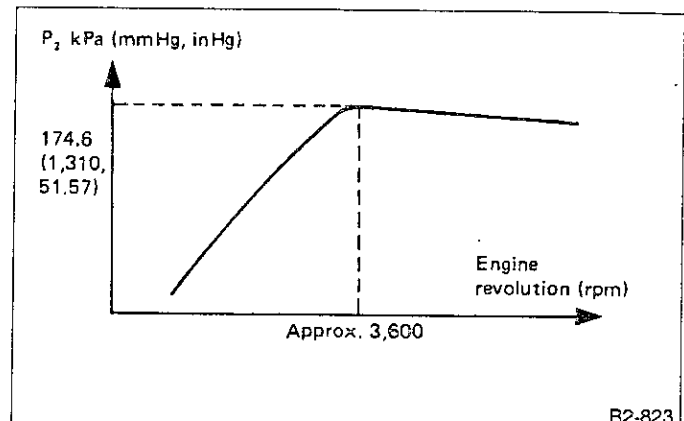


Fig. 38

3. LUBRICATION OF TURBOCHARGER

The turbocharger is lubricated by the engine oil branched out from the oil pump. Since the turbocharger turbine and the compressor shaft reach a maximum of several hundred thousand revolutions per minute, the full-floating type bearings are used to form

desirable lubrication films on their inside and outside during running.

Further the oil supplied to the turbocharger also plays an important role of cooling the heat from exhaust gas in the turbine not to propagate to the bearings.

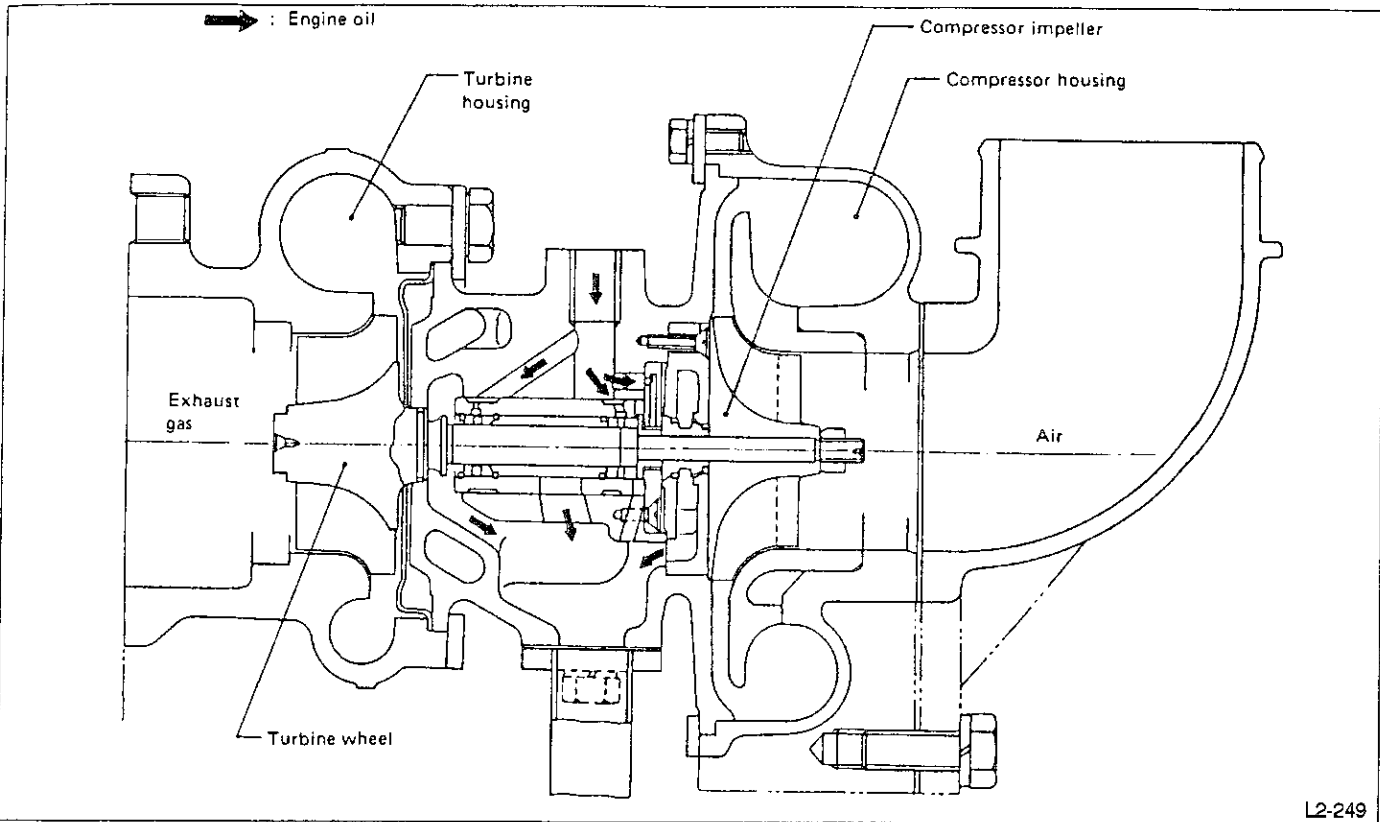


Fig. 39

4. COOLING OF TURBOCHARGER

The turbocharger is water cooled for higher reliability and durability. The coolant from the coolant drain hose under the engine cylinder head is led to the coolant

passage, through a pipe, provided in the turbocharger bearing housing. After cooling the bearing housing, the coolant is led into the coolant filler tank through a pipe.

C: INTERCOOLER SYSTEM

1. GENERAL

The intercooler system is designed to cool hot intake air compressed by the turbocharger to improve intake air charging efficiency, thereby preventing engine knock

and reducing fuel consumption. The intercooler itself is water-cooled and features high cooling efficiency and reduced resistance to airflow.

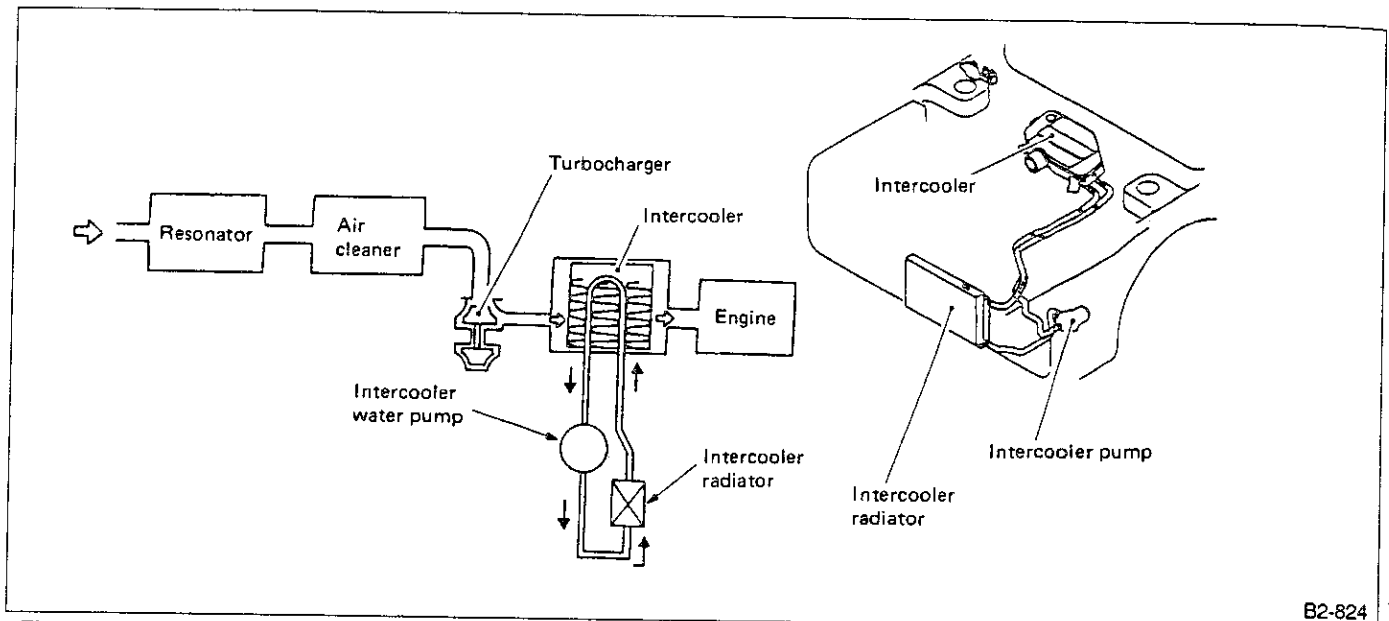


Fig. 40

B2-824

2. INTERCOOLER

The intercooler is composed of an aluminum alloy casing and a main body. It is used to efficiently cool down hot air resulting from compression in the turbocharger. Cooling water passes through the intercooler core which is formed by a stack of five core elements.

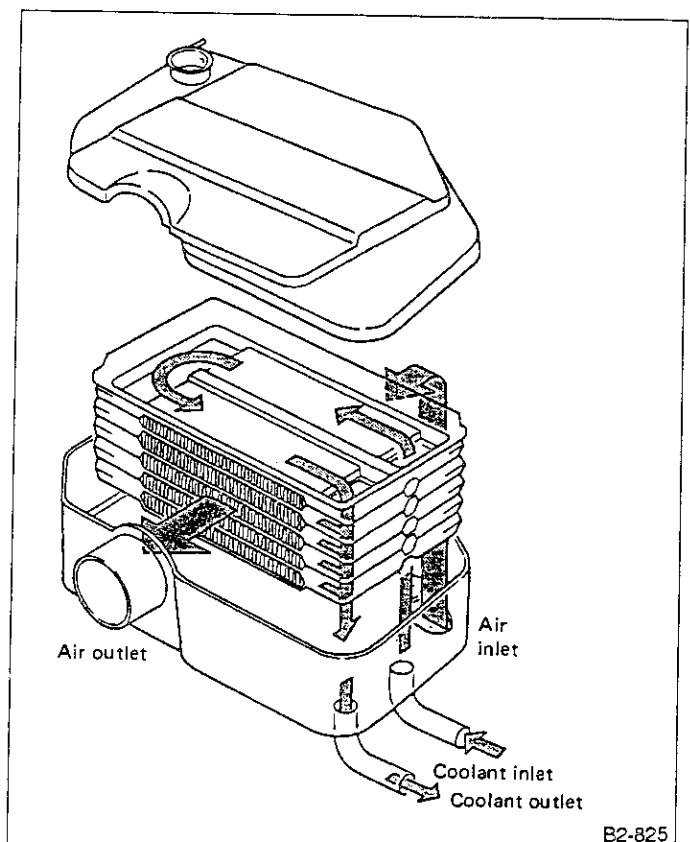


Fig. 41

B2-825

3. RADIATOR (FOR INTERCOOLER)

- The intercooler radiator uses an aluminum fin & tube type structure.
- The left-side tank is split into two sections so that cooling water can be returned for efficient heat dissipation.
- An air bleeder plug is provided to bleed off unwanted air and prevent water pump trouble.
- A drain plug is provided for draining the cooling water.

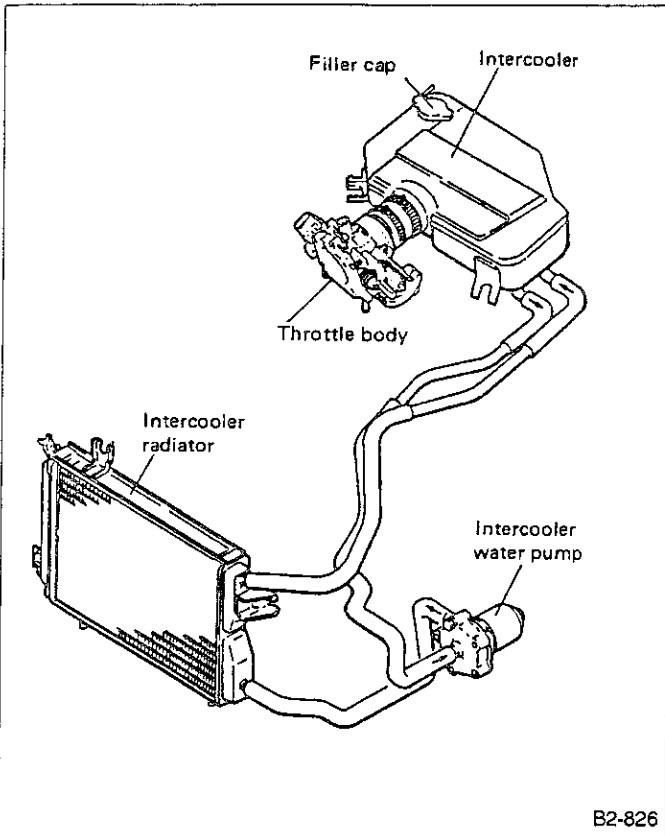


Fig. 42

4. WATER PUMP

- The water pump is driven by an electric motor and is composed of an impeller, armature, and other components.
- It operates on 28 watts of power. However, if the throttle opening exceeds 80% and pump demand is increased, power input to the pump is increased to 50 watts.

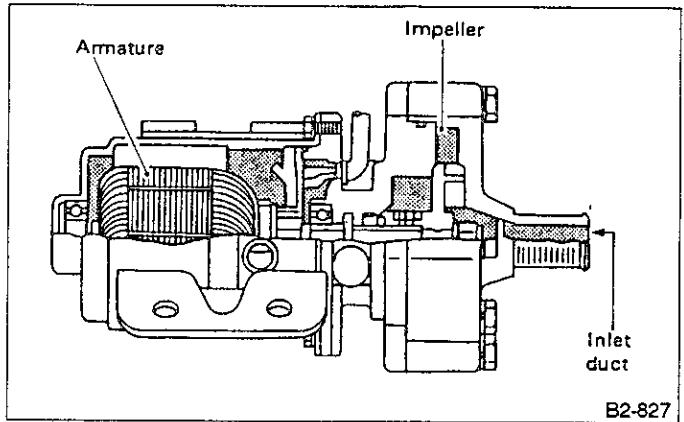


Fig. 43

5. WATER PUMP CONTROL

1) The water pump delivery is increased to a high level only when the throttle opening is greater than 80%. Normally, the pump terminal voltage is maintained at a low level to reduce power consumption and extend the pump service life.

2) The pump output is normally low (28 watts) when the ignition switch is ON, and changed to high (50 watts) when the throttle opening exceeds 80% as shown below.

Ignition switch	Throttle opening ratio is more than 80%	Water pump
OFF	X	OFF
ON	X	Low (28 w)
ON	○	Hi (50 w)

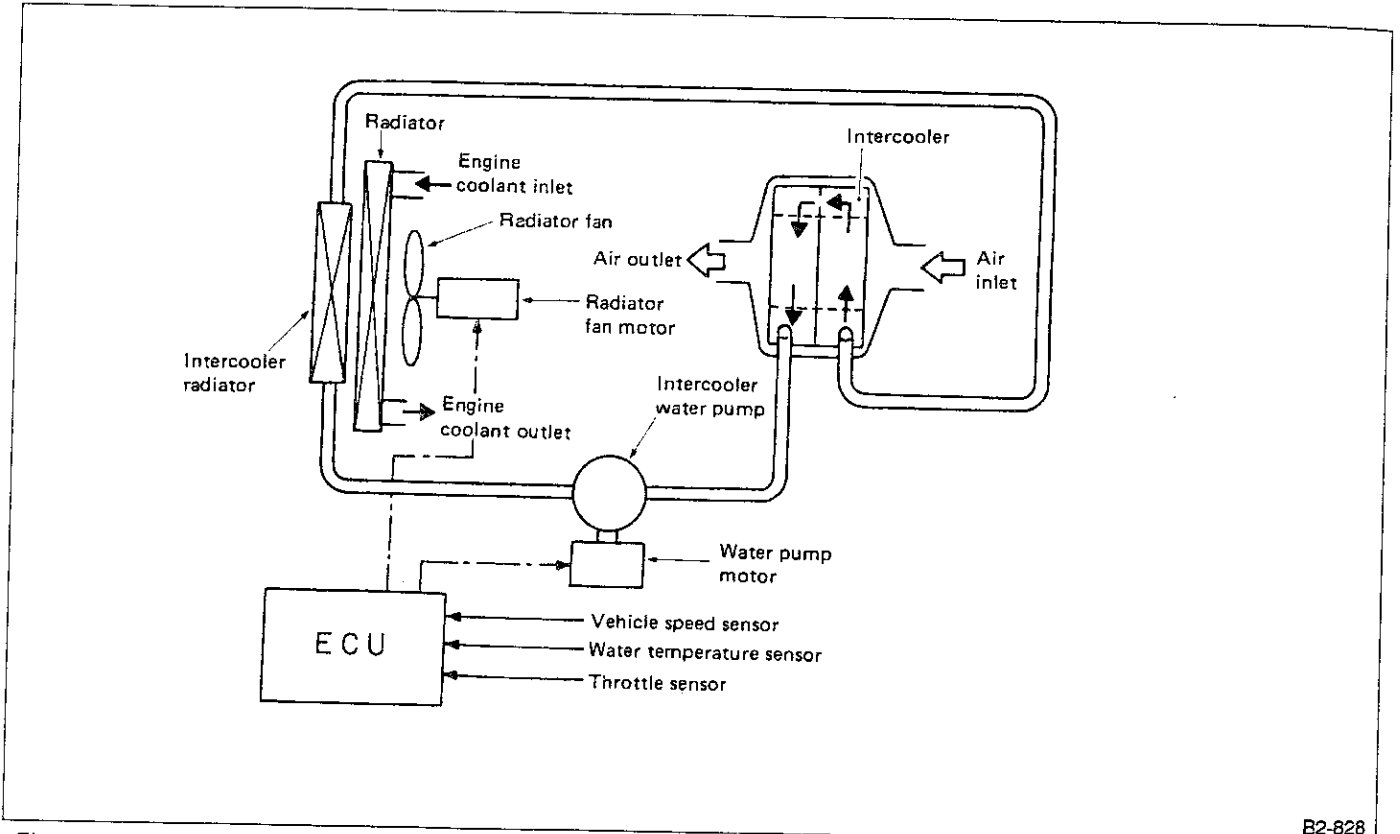


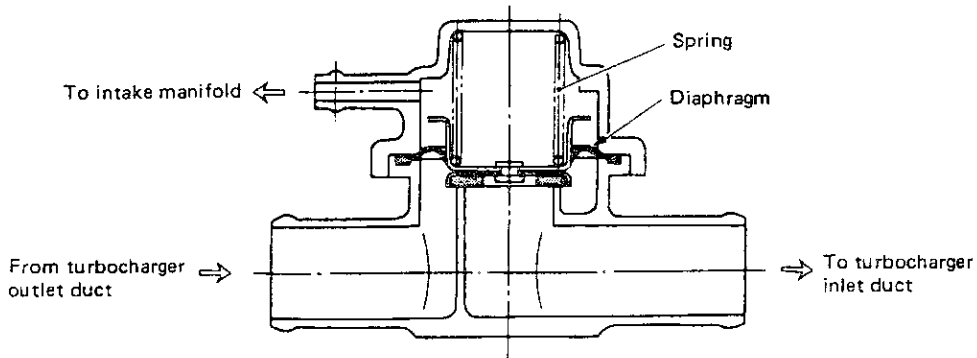
Fig. 44

B2-828

D: AIR BY-PASS VALVE

When a throttle valve is suddenly closed, low air suction noise may occur due to a sudden rise of the air pressure in the passage between the turbocharger and throttle

body. To prevent this, an air by-pass valve and air passage are provided. The air by-pass valve, actuated by the vacuum created by a sudden closure of the throttle valve, allows the suction air to by-pass the turbocharger and pass directly upstream, thus lowering the pressure in the air passage.



B2-830

Fig. 45

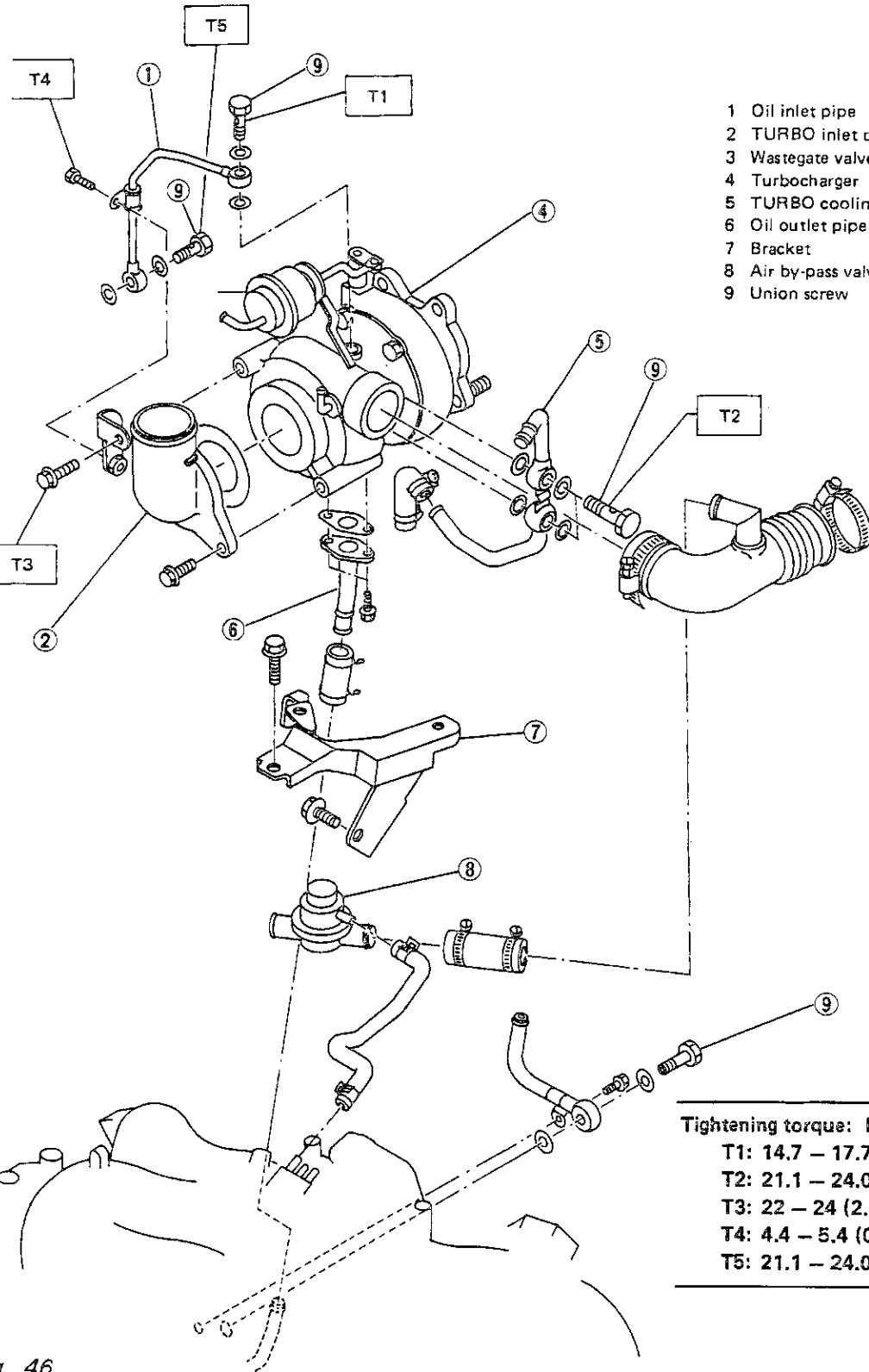
S SPECIFICATION AND SERVICE DATA

A: SPECIFICATIONS

Intercooler system		Water cooled type	
Intercooler ASSY	Type	Drain cup type	
	Core dimensions	270 x 128 x 70 mm (10.63 x 5.04 x 2.76 in)	
	Cooling capacity	3.954 kW (3,400 kcal/h, 13,491 BTU/h)	
Radiator	Type	Fin and tube type	
	Core dimensions	400 x 247.5 x 32 mm (15.75 x 9.74 x 1.26 in)	
	Cooling capacity	5.408 kW (4,650 kcal/h, 18,451 BTU/h)	
Water pump	Discharge performance (12 V)	Discharge	15 ℓ (4.0 US gal, 3.3 Imp gal)/min.
		Total water head	2.0 mAq (6.6 ftAq)
	Motor	50W (Hi), 20W (Lo)	
Relay	Standards	12 V, Normal open	
	Dropping resistor	15 W, 1 Ω	
Coolant capacity		1.9 ℓ (2.0 US qt, 1.7 Imp qt)	

COMPONENT PARTS

Turbocharger



- 1 Oil inlet pipe
- 2 TURBO inlet duct
- 3 Wastegate valve controller
- 4 Turbocharger
- 5 TURBO cooling pipe
- 6 Oil outlet pipe
- 7 Bracket
- 8 Air by-pass valve
- 9 Union screw

Tightening torque: N·m (kg-m, ft-lb)	
T1:	14.7 – 17.7 (1.50 – 1.80, 10.9 – 13.0)
T2:	21.1 – 24.0 (2.15 – 2.45, 15.6 – 17.7)
T3:	22 – 24 (2.2 – 2.4, 16 – 17)
T4:	4.4 – 5.4 (0.45 – 0.55, 3.3 – 4.0)
T5:	21.1 – 24.0 (2.15 – 2.45, 15.6 – 17.7)

2. Intercooler

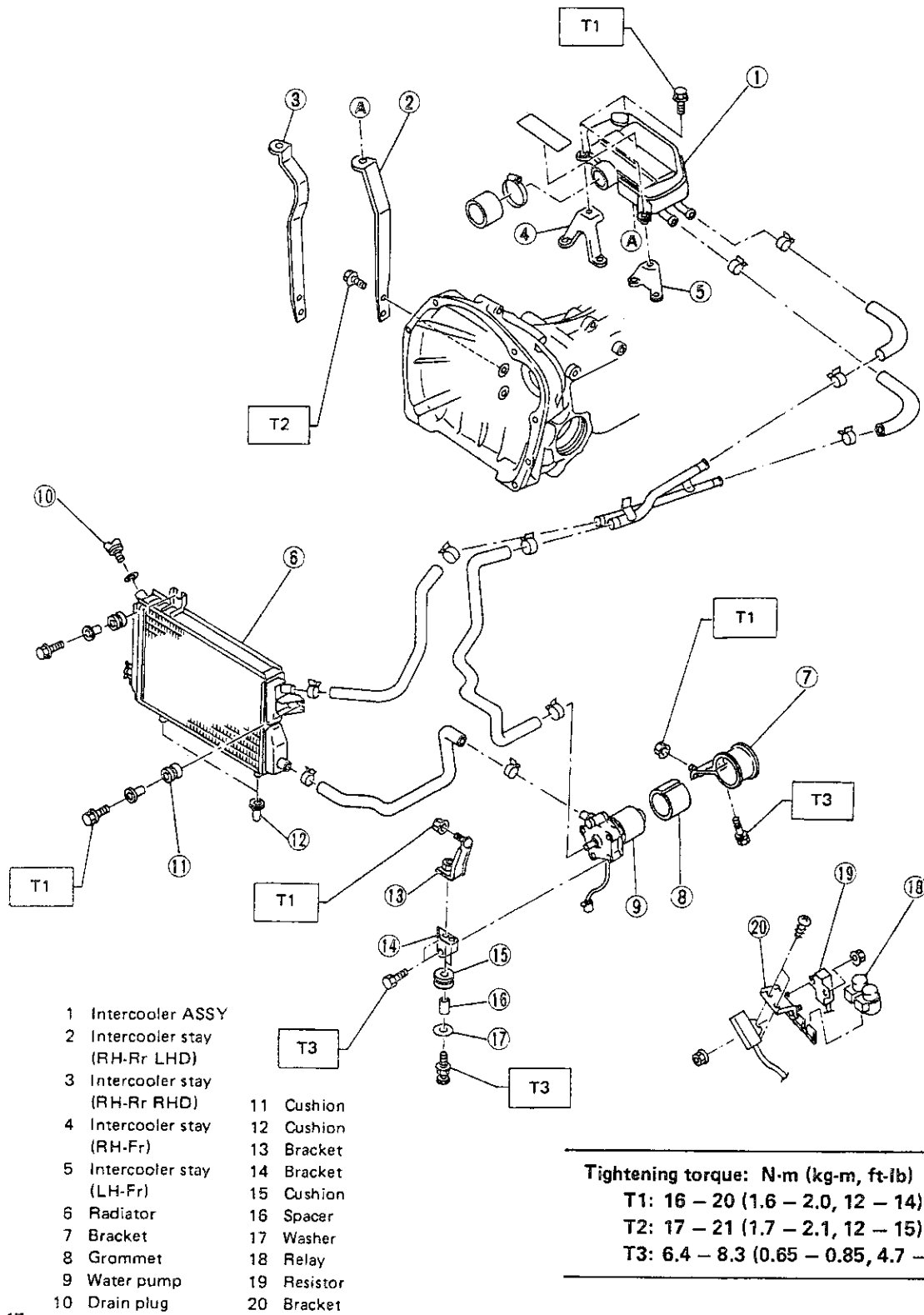


Fig. 47

W SERVICE PROCEDURE

1. Turbocharger System

A: TROUBLE DIAGNOSIS

If the turbocharger system fails, any of the following phenomena can occur.

- 1) Excessively high supercharging pressure:
 - (1) Engine knocking
- 2) Excessively low supercharging pressure:
 - (1) Lack of engine power
 - (2) Poor acceleration performance
 - (3) Considerable fuel consumption
- 3) Oil leak from turbocharger:
 - (1) Excessive oil consumption
 - (2) White exhaust smoke

(However, the phenomena 2) can also result from other causes, such as air leakage from the intake system, exhaust system leakage or obstruction, incorrect ignition timing, malfunctioning knock control system, defects in the MPFI control system.)

B: REMOVAL

1. RELATED PARTS

- 1) Remove intercooler.
(Refer to 2. Intercooler System [W2A1].)
- 2) Drain engine coolant.
- 3) Remove resonator chamber and air inlet duct from turbocharger.

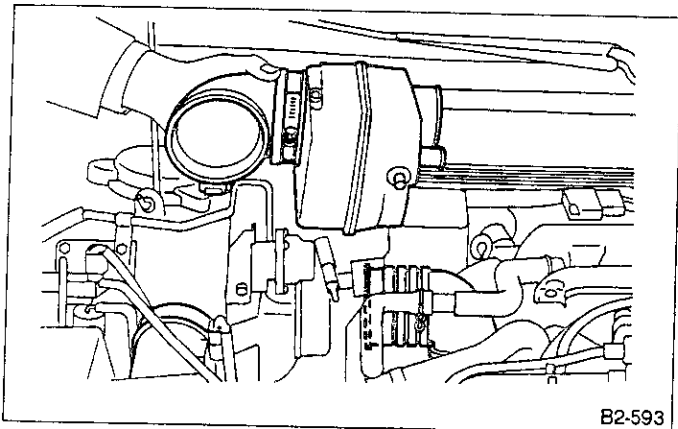


Fig. 48

- 4) Disconnect wastegate control vacuum hoses from intake manifold, turbocharger and wastegate controller.

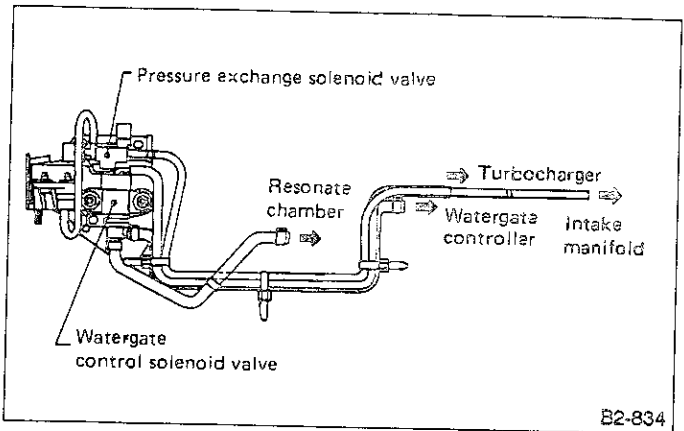


Fig. 49

- 5) Remove turbocharger cooling duct.

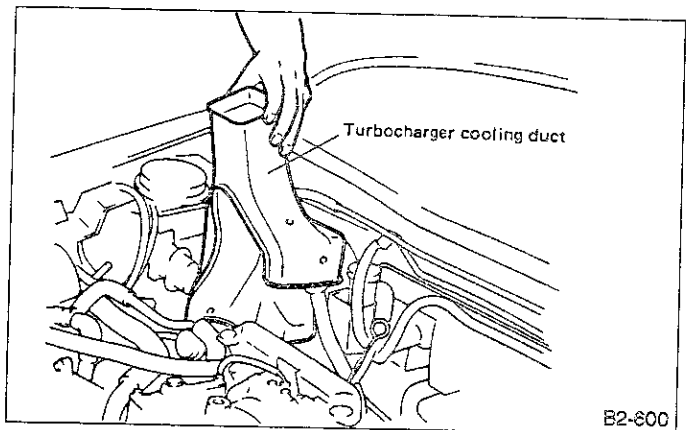


Fig. 50

- 6) Disconnect O₂ sensor connector.
 - 7) Separate center exhaust pipe from turbocharger.
- Do not allow tool to come into contact with wastegate control rod since it might bend.

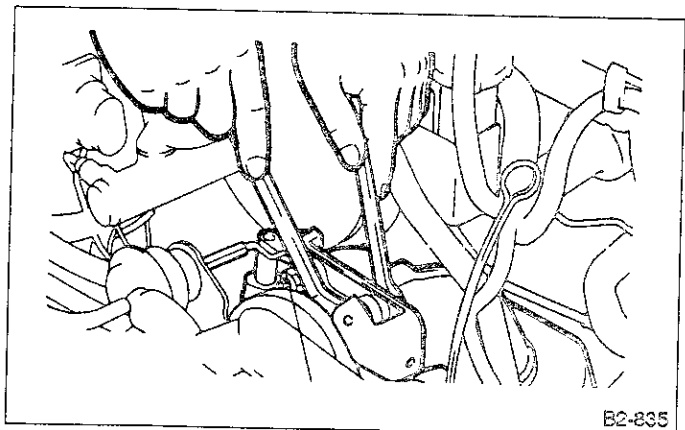


Fig. 51

- 8) Remove center exhaust pipe.
(Refer to 2-9 Exhaust System [W3A0].)
- 9) Remove turbocharger lower cover.

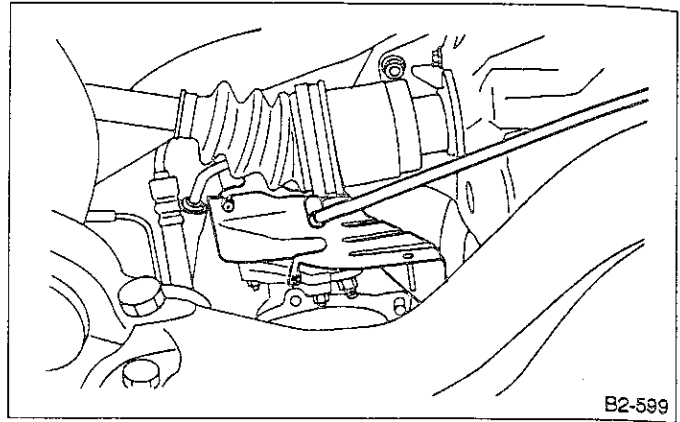


Fig. 52

2. TURBOCHARGER

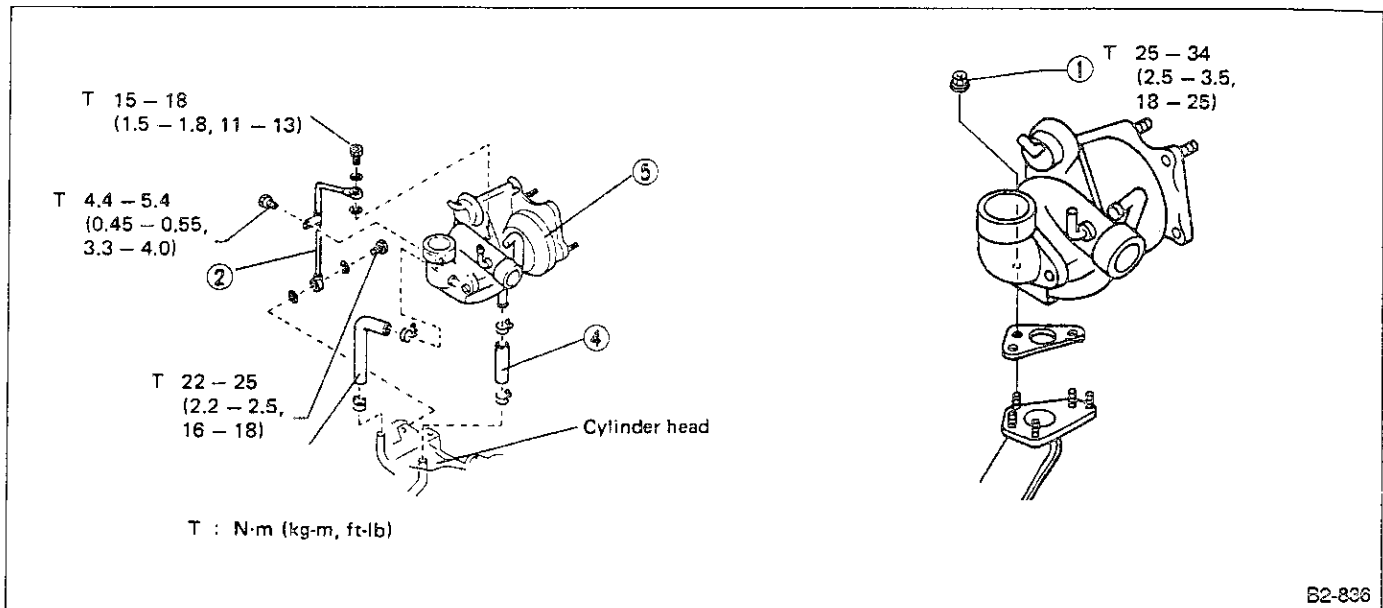


Fig. 53

- 1) Remove nuts which secure turbocharger to turbo-joint pipe.
Be careful not to allow tool to come into contact with wastegate controller.

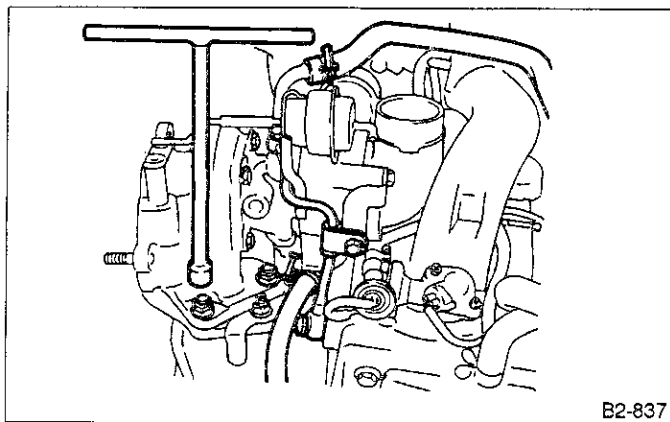


Fig. 54

- 2) Remove union screws, and disconnect oil inlet pipe from turbocharger and cylinder head.
- 3) Loosen clamp and disconnect hose from turbocharger cooling pipe.
- 4) Loosen oil outlet hose clamp on cylinder head side.
- 5) While lifting turbocharger, disconnect oil outlet hose.
- 6) To install, reverse installation procedures.
Make sure wastegate control vacuum hose is connected firmly.

C: INSPECTION

1. WASTEGATE VALVE

- 1) Check connecting hose between wastegate valve, turbocharger and duty solenoid valve for looseness or disconnection, as well as cracks and damage.
- 2) Disconnect the wastegate valve control connecting hose from actuator, and connect checking rubber hose. Plug the disconnected rubber hose.
- 3) Apply air pressure 42.2 — 51.0 kPa (0.43 — 0.52 kg/cm², 6.1 — 7.4 psi) to the checking rubber hose, and see whether the wastegate valve link operates or not.

Excessive pressure may cause damage to the wastegate valve control diaphragm. Be sure to check that the pressure is 42.2 — 51.0 kPa (0.43 — 0.52 kg/cm², 6.1 — 7.4 psi) with a pressure gauge before applying.

2. SUPERCHARGING PRESSURE

- 1) Disconnect vacuum hose (for auxiliary purge valve) from pressure exchange solenoid valve and connect rubber hose to use positive pressure gauge. Lead the rubber hose into the passenger compartment, and connect it to the positive pressure gauge.
- 2) Disconnect two rubber hoses from duty solenoid valve and connect these hoses using a connector. Plug duty solenoid valve.
- 3) After warming up engine, make a test run. Read the supercharging pressure on the positive pressure gauge when the vehicle is running at approximately 3,600 rpm with a fully open throttle.

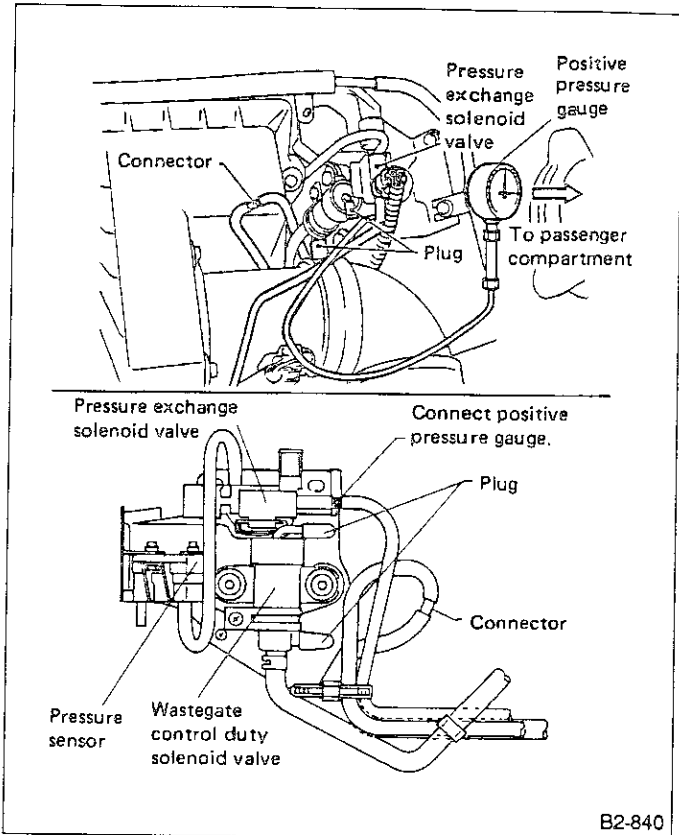


Fig. 55

Phenomenon	Judgement
Supercharging pressure is in the 42.7 to 50.7 kPa (320 to 380 mmHg, 12.60 to 14.96 inHg) range.	Normal
Supercharging pressure exceeds the 50.7 kPa (380 mmHg, 14.96 inHg) upper limit. (1) Cracked or disconnected wastegate valve control rubber hoses (2) Inoperative and closed wastegate valve	Replace or connect rubber hose. Replace turbocharger.
Supercharging pressure is below the 42.7 (320 mmHg, 12.60 inHg) lower limit.	Faulty turbocharger. ↓ Replace turbocharger.

3. TURBOCHARGER

1) Oil leakage from the exhaust gas side (turbine side)

Remove the center exhaust pipe and examine the turbocharger from the exhaust gas side.

If there are excessive carbon deposits on the turbine exhaust side, oil is leaking from the turbine.

(In this case, oil may also be leaking from between the turbine chamber and bearing chamber.)

2) Oil leakage from the inlet side (blower side)

(1) The turbocharger is not necessarily leaking oil when oil is present on the blower side. The oil is likely to have come from oil mists contained in the blowby gases flow in the inlet system.

(2) When oil is leaking from the inlet system, it is accompanied by a rattle from the turbocharger shaft when it moves in an axial or radial direction. Remove the turbocharger from the engine and determine if the shaft rattles.

(Limit of rattling: Measure with a dial gauge.)

a. Axial rattling:

0.09 mm (0.0035 in)

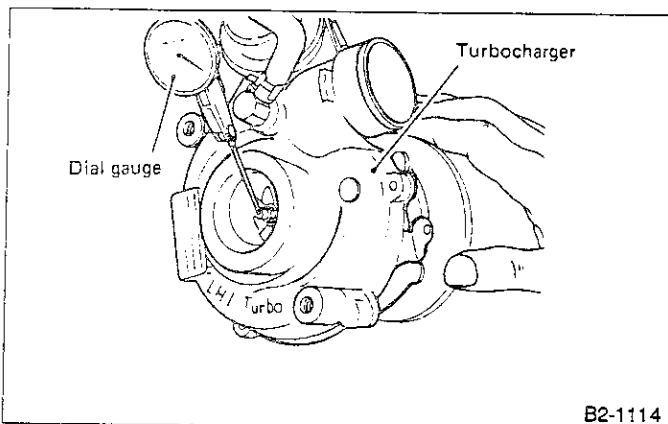


Fig. 56

b. Radial rattling:

0.17 mm (0.0067 in) when the turbine side and blower side of the shaft are moved circumferentially at the same time.

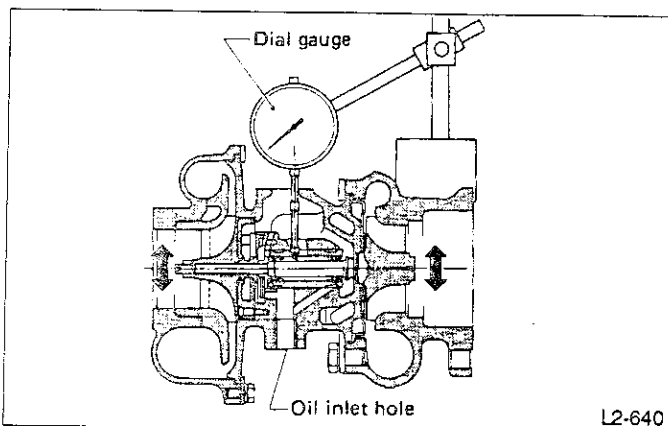


Fig. 57

If anything unusual is found, replace the turbocharger.

a. The turbocharger proper cannot be disassembled or adjusted.

b. When removing and installing the turbocharger, do not allow dirt and dust to enter the inlet and outlet openings of the turbine and blower. Any foreign matter allowed to enter, will undoubtedly damage the turbine and blower blades as soon as the turbocharger goes into operation again.

c. Likewise, cover the open end of the front exhaust pipe. If foreign matter is allowed to enter, the turbine blades will be instantaneously destroyed when the turbocharger is put into operation.

3) Oil leakage from the connection of the oil delivery pipe

Visually inspect the connections of the oil delivery pipe with the turbocharger and oil pump. If oil is leaking, replace the washer of the union screw and tighten it to the specified tightening torque.

Tightening torque:

14.7 — 17.7 N·m

(1.50 — 1.80 kg-m, 10.8 — 13.0 ft-lb)

4) Coolant leakage from connection of the cooling pipe

Visually check the connection between turbocharger and cooling pipe, between engine cylinder head and cooling pipe, and the hose clamped area for leakage of coolant. If leakage is detected, replace the washer at the union screw, and tighten the screw to the specified torque. Check the hose for cracks and damage at the clamped area before tightening the clamp. If the hose is faulty, replace with a new one.

Tightening torque:

22 — 25 N·m

(2.2 — 2.5 kg-m, 16 — 18 ft-lb)

2. Intercooler System

A: REMOVAL

1. INTERCOOLER

- 1) Draining coolant from intercooler
 - (1) Loosen filler cap on intercooler to facilitate draining coolant.
 - (2) Remove drain plug from radiator to drain coolant.

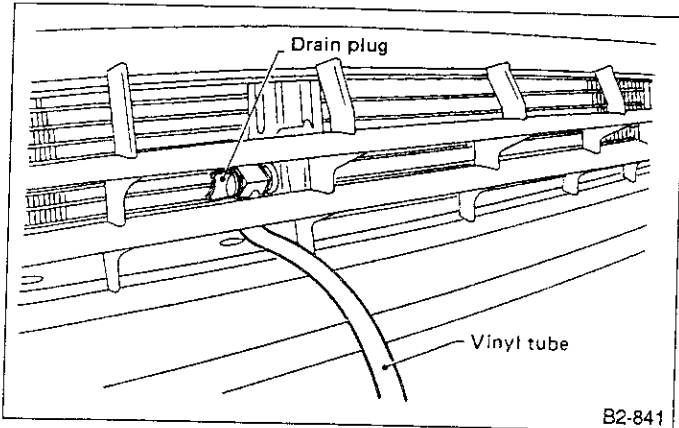


Fig. 58

2) Remove intercooler.

- (1) Disconnect coolant hoses.

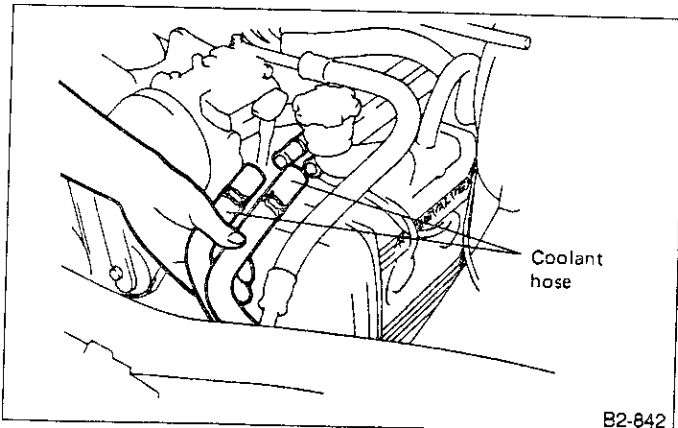


Fig. 59

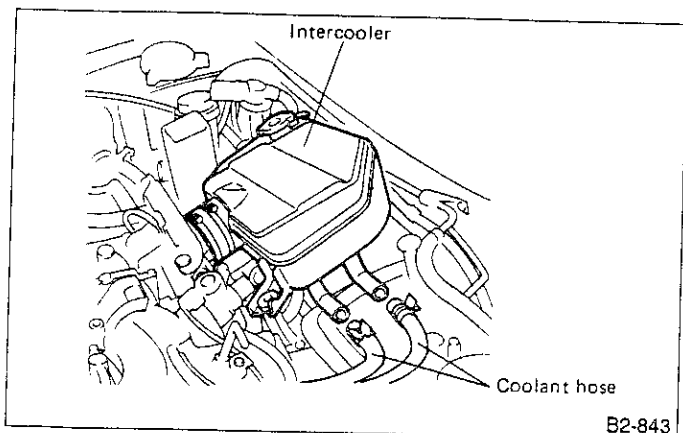


Fig. 60

- (2) Remove intercooler attaching bolts.

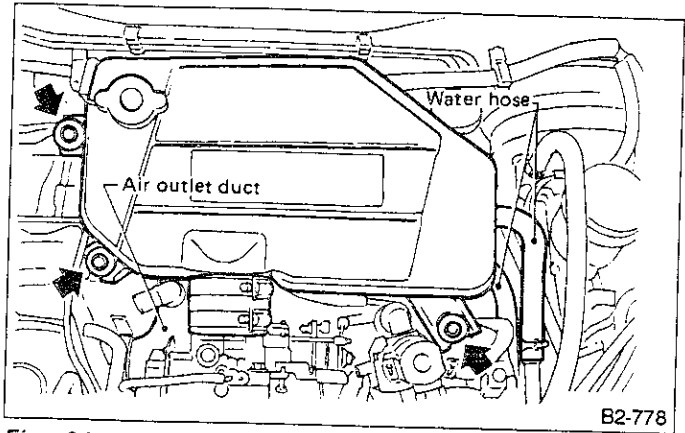


Fig. 61

- (3) Remove air by-pass valve.
- (4) Remove intercooler inlet and outlet ducts. Remove inlet and outlet duct clamps on turbocharger and throttle body sides. While moving intercooler, disconnect both inlet and outlet duct hoses at the same time.

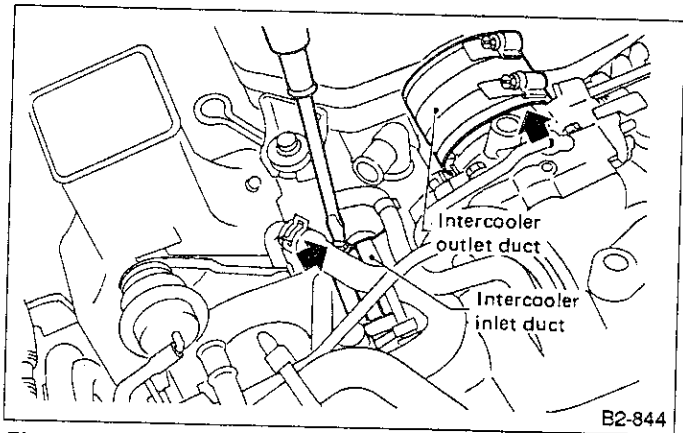


Fig. 62

2. RADIATOR

- 1) Remove front grille.
- 2) Remove front bumper.
- 3) Drain coolant from intercooler.
- 4) Remove radiator.
 - (1) Loosen clamps and disconnect inlet and outlet hoses.
 - (2) Remove two radiator attaching bolts and remove radiator.

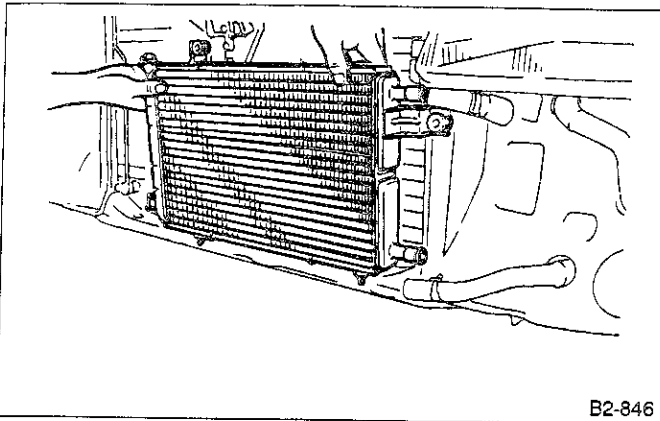


Fig. 63

3. WATER PUMP

- 1) Drain coolant from intercooler.
- 2) Remove front left tire.
- 3) Remove mud guard.
- 4) Remove water pump.
 - (1) Remove water pump bracket attaching nuts from engine compartment side.
 - (2) Remove bolts (and rubber mounts) securing water pump to car body.
 - (3) Disconnect water pump harness connector.
 - (4) Loosen clamp and disconnect hose from water pump.

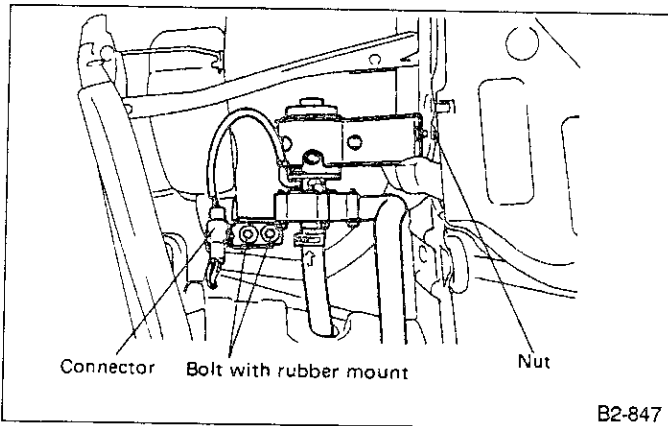


Fig. 64

B: INSPECTION

- 1) Check intercooler and radiator.
 - (1) Check intercooler for deformities, and air and coolant outlets for cracks.
 - (2) Check radiator core for damage, and coolant outlet pipe for cracks.
- 2) Check water hose for cracks or damage.
- 3) Check water pump condition.
 - (1) Connect hoses to water pump inlet and outlet and dip open ends of the hoses into container filled with coolant. Apply 12 volts across motor terminals to make sure coolant circulates properly.

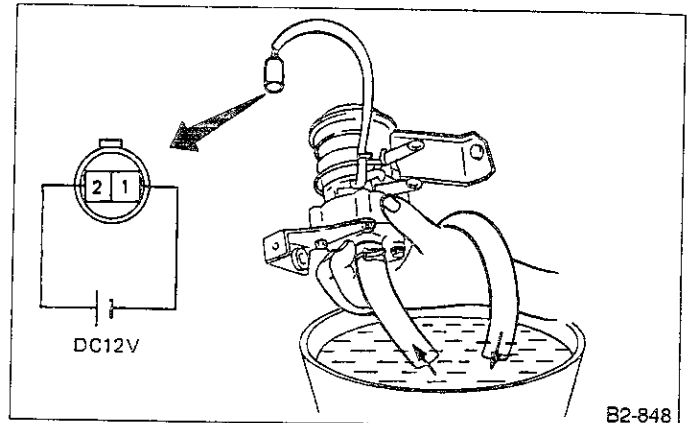


Fig. 65

If coolant does not circulate, replace faulty parts.

C: INSTALLATION

1. WATER PUMP AND RADIATOR

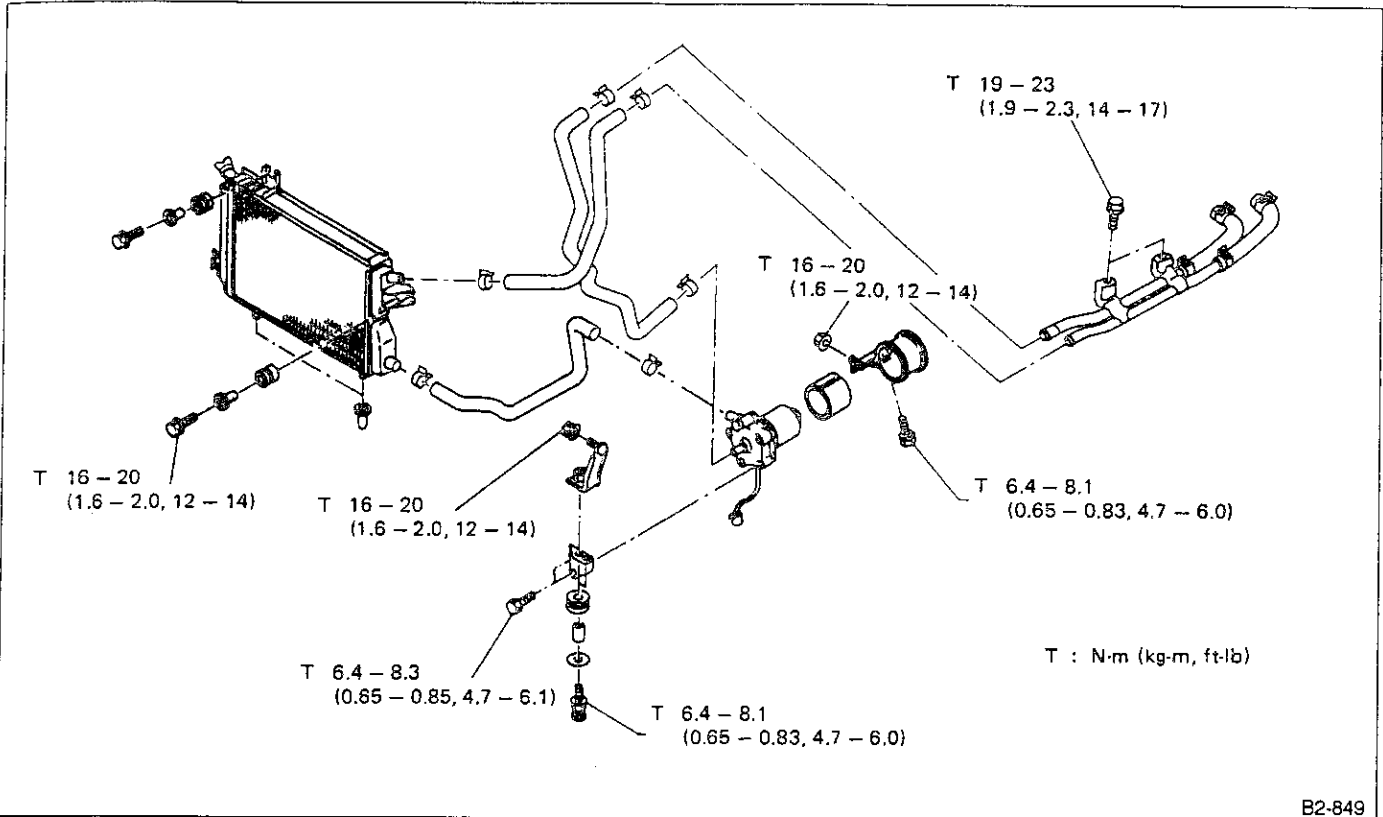


Fig. 66

Installation is in the reverse order of removal procedure.

2. INTERCOOLER

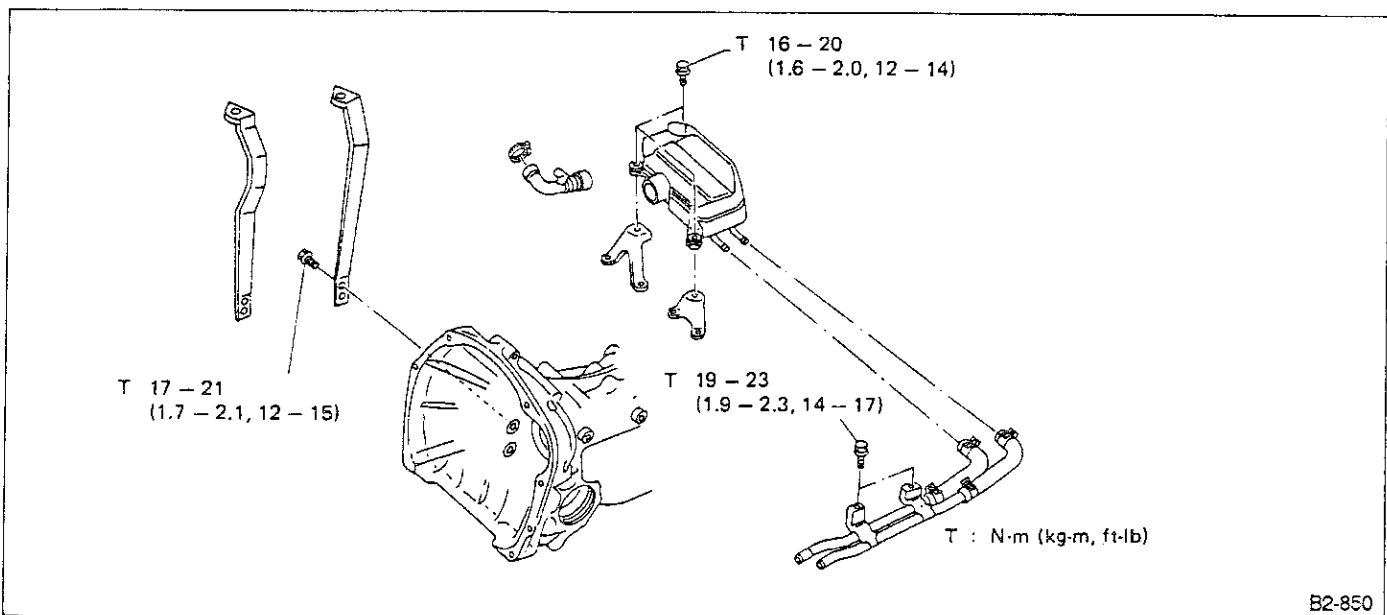


Fig. 67

1) Intercooler installation

- (1) Connect inlet and outlet ducts and hose clamps to intercooler.
- (2) Insert intercooler inlet duct in turbocharger air outlet and outlet duct in throttle body. Clamp both ducts securely.

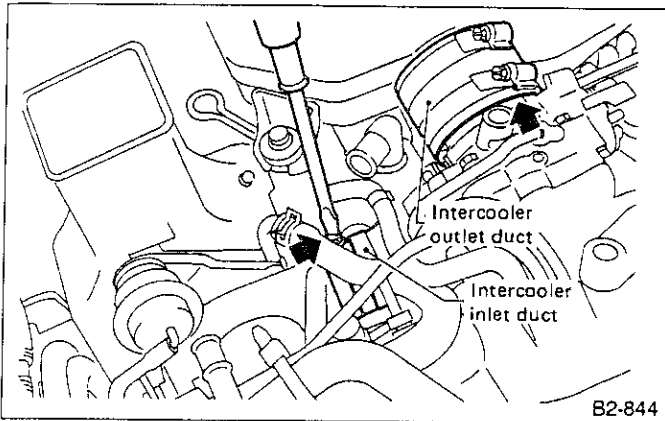


Fig. 68

- (3) Install intercooler on stay.
- (4) Connect coolant hose.

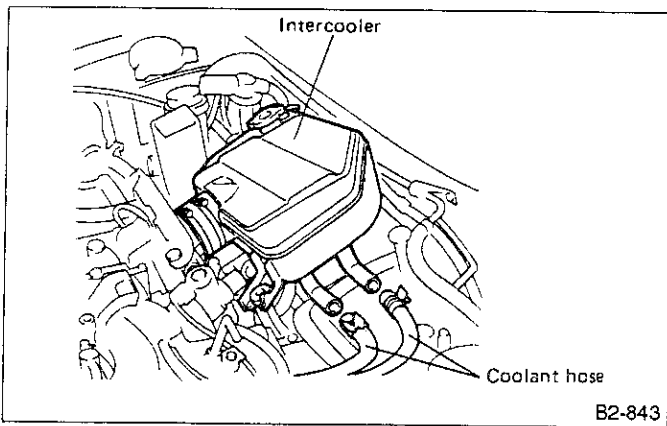


Fig. 69

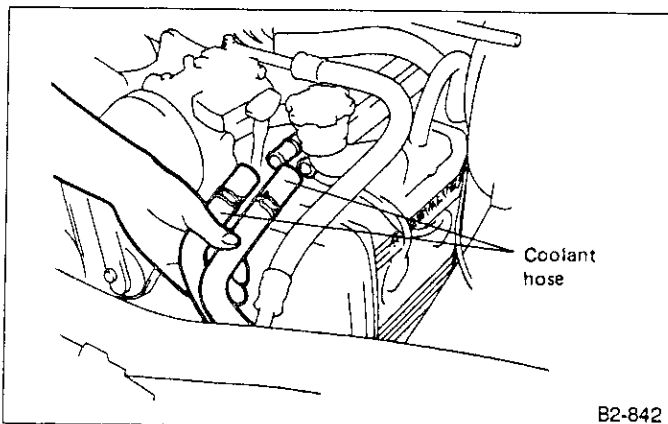


Fig. 70

- (5) Install air by-pass valve.

2) Replenishing intercooler coolant

- (1) Remove filler cap from intercooler and loosen air vent plug from right upper side of intercooler radiator.
- (2) Pour coolant into intercooler until it runs out of air vent plug. Tighten air vent plug.
- (3) Add coolant up to filler opening. Install and tighten filler cap.

Coolant capacity:

Approximately 1.9 liter (2.0 US qt, 1.7 Imp qt)

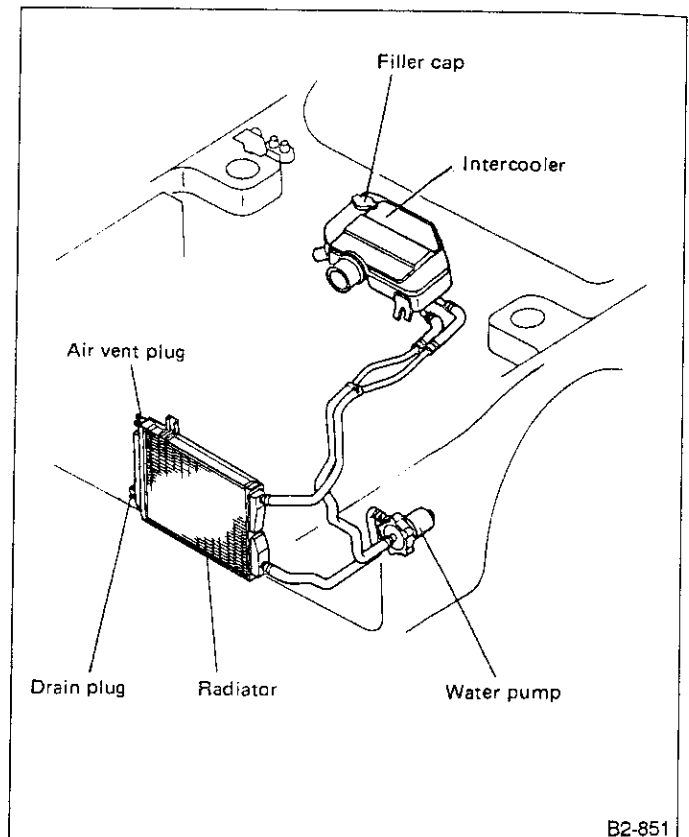


Fig. 71

T TROUBLESHOOTING

1. Precautions

- 1) Never connect the battery in reverse polarity.
 - The MPFI control unit will be destroyed instantly.
 - The fuel injector and other part will be damaged in just a few minutes more.
- 2) Do not disconnect the battery terminals while the engine is running.
 - A large counter electromotive force will be generated in the alternator, and this voltage may damage electronic parts such as ECU (MPFI control unit), etc.
- 3) Before disconnecting the connectors of each sensor and the ECU, be sure the turn off the ignition switch.
 - Otherwise, the ECU may be damaged.
- 4) Before removing ECU from the located position, disconnect two cables on battery.
- 5) The connectors to each sensor in the engine compartment and the harness connectors on the engine side and body side are all designed to be waterproof. However, it is still necessary to take care not to allow water to get into the connectors when washing the vehicle, or when servicing the vehicle on a rainy day.
- 6) Every MPFI-related part is a precision part. Do not drop them.
- 7) Observe the following cautions when installing a radio in MPFI equipped models.
 - a. The antenna must be kept as far apart as possible from the control unit.
(The ECU is located under the steering column, inside of the instrument panel lower trim panel.)
 - b. The antenna feeder must be placed as far apart as possible from the ECU and MPFI harness.
 - c. Carefully adjust the antenna for correct matching.
 - d. When mounting a large power type radio, pay special attention to items a. thru c. above.
 - Incorrect installation of the radio may affect the operation of the ECU.

8) Before disconnecting the fuel hose, disconnect the fuel pump connector and crank the engine for more than five seconds to release pressure in the fuel system. If engine starts during this operation, run it until it stops.

2. Pre-inspection

Before troubleshooting, check the following items which might affect engine problems:

1. POWER SUPPLY

- 1) Measure battery voltage and specific gravity of electrolyte.

Standard voltage: 12 V

Specific gravity: Above 1.260

- 2) Check the condition of the main and other fuses, and harnesses and connectors. Also check for proper grounding.

2. CAPS AND PLUGS

- 1) Check that the fuel cap is properly closed.
- 2) Check that the oil filler cap is properly closed.
- 3) Check that the oil level gauge is properly inserted.

3. INTAKE MANIFOLD VACUUM PRESSURE

- 1) After warming up the engine, measure intake manifold vacuum pressure while at idle.

Standard vacuum pressure:

More than - 66.7 kPa (- 500 mmHg, - 19.69 inHg)

- 2) Unusual vacuum pressure occurs because of air leaks, fuel or engine problems. In such a case, engine idles roughly.

4. FUEL PRESSURE

- 1) Fuel pressure elimination
 - (1) Disconnect the fuel pump connector.
 - (2) Start the engine.
 - (3) Leave the engine until it stalls.
 - (4) After it stalls, crank the starter for approximately 5 seconds and turn the ignition switch to "OFF".
- 2) Fuel pressure gauge installation
 - (1) Connect a fuel pressure gauge between the fuel strainer and the fuel hose.
 - (2) Connect the fuel pump connector.
- 3) Fuel pressure measurement
 - (1) Start the engine. Measure fuel pressure while allowing the engine to idle.

Fuel pressure:

177 — 206 kPa (1.8 — 2.1 kg/cm², 26 — 30 psi)

- (2) Race the engine to ensure that fuel pressure increases.

- (3) Stop the engine and connect the D-check connector. Turn the ignition switch to "ON" (engine "OFF") and measure fuel pressure.

Fuel pressure:

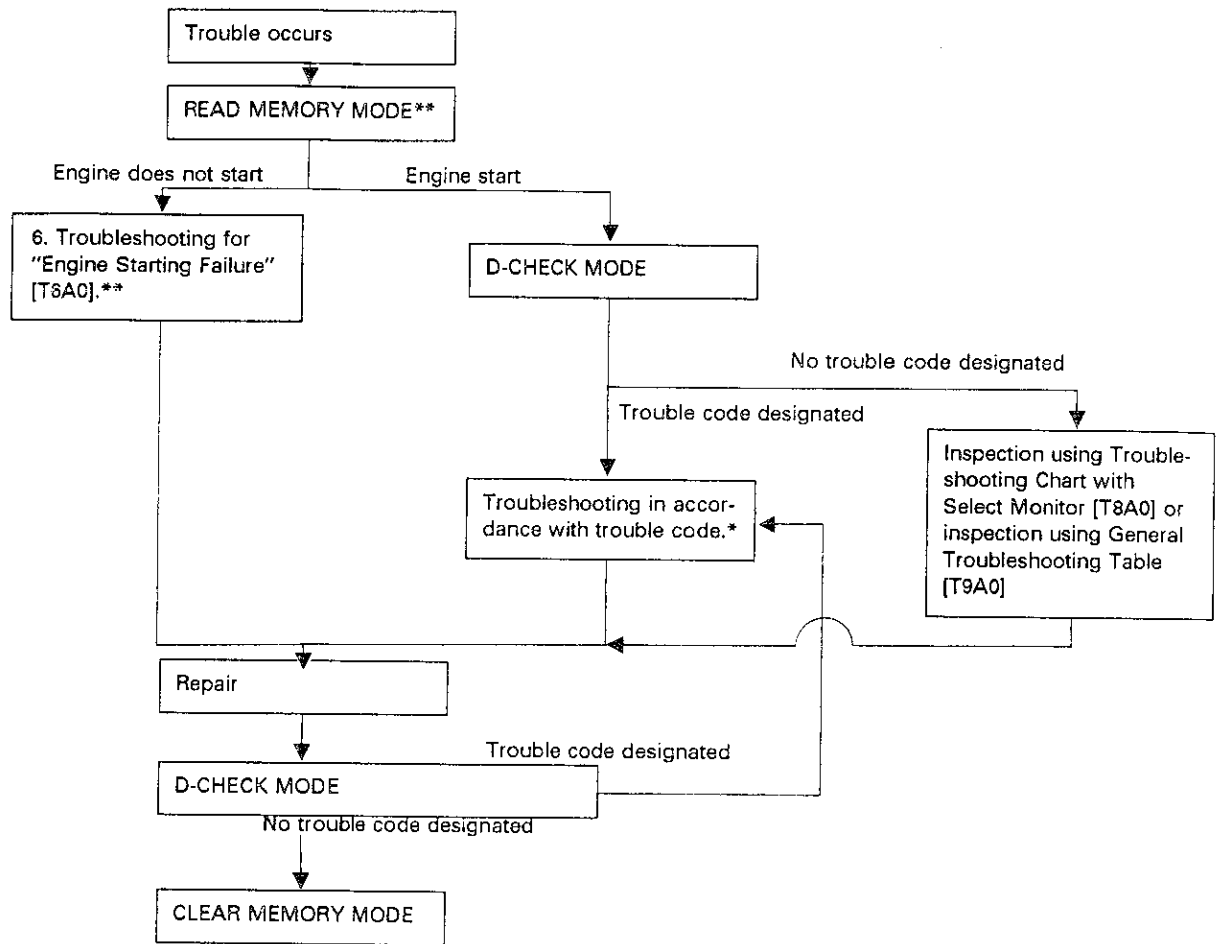
235 — 265 kPa (2.4 — 2.7 kg/cm², 34 — 38 psi)

5. ENGINE GROUNDING

Make sure the engine grounding terminal is properly connected to the engine.

3. Troubleshooting Chart for Self-diagnosis System

A: BASIC TROUBLESHOOTING PROCEDURE



*: When more than one trouble code is outputted, begin troubleshooting with the smallest trouble code number and proceed to the next higher code.

After correcting each problem, conduct the D-check and ensure that the corresponding trouble code no longer appears.

** : When a trouble code is displayed in the read-memory mode, conduct troubleshooting measures which correspond with the code.

a. Check the connector while it is connected unless specified otherwise.

b. Be sure to check again from the beginning in order to prevent secondary trouble caused by repair work.

c. When checking with the vacuum hose disconnected from the vacuum switch at E/G on, be sure to plug the hose.

B: LIST OF TROUBLE CODE

1. TROUBLE CODE

Trouble code	Item	Content of diagnosis
11.	Crank angle sensor	No signal entered from crank angle sensor, but signal entered from cam angle sensor.
12.	Starter switch	Abnormal signal emitted from ignition switch.
13.	Cam angle sensor	No signal entered from cam angle sensor, but signal entered from crank angle sensor.
14.	Injector #1	Fuel injector inoperative. (Abnormal signal emitted from monitor circuit.)
15.	Injector #2	
16.	Injector #3	
17.	Injector #4	
21.	Water temperature sensor	Abnormal signal emitted from water temperature sensor.
22.	Knock sensor	Abnormal voltage produced in knock sensor monitor circuit.
23.	Air flow sensor	Abnormal voltage input entered from air flow sensor.
24.	By-pass air control solenoid valve	Solenoid valve inoperative. (Abnormal signal emitted from monitor circuit.)
31.	Throttle position sensor	Abnormal voltage input entered from throttle sensor.
32.	O ₂ sensor	O ₂ sensor inoperative.
33.	Vehicle speed sensor 2	Abnormal voltage input entered from speed sensor.
35.	Purge control solenoid valve	Solenoid valve inoperative.
42.	Idle switch	Abnormal voltage input entered from idle switch.
44.	Wastegate control duty solenoid valve	Duty solenoid valve inoperative.
45.	Pressure sensor and pressure exchange solenoid valve	Faulty sensor or pressure exchange solenoid valve inoperative.
49.	Air flow sensor	Use of improper air flow sensor.
51.	Neutral switch	Abnormal signal entered from neutral switch.

2. HOW TO READ TROUBLE CODE (FLASHING)

The CHECK ENGINE LIGHT flashes the code corresponding to the faulty part.

The long segment (1.2 sec on) indicates a "ten", and the short segment (0.2 sec on) signifies "one".

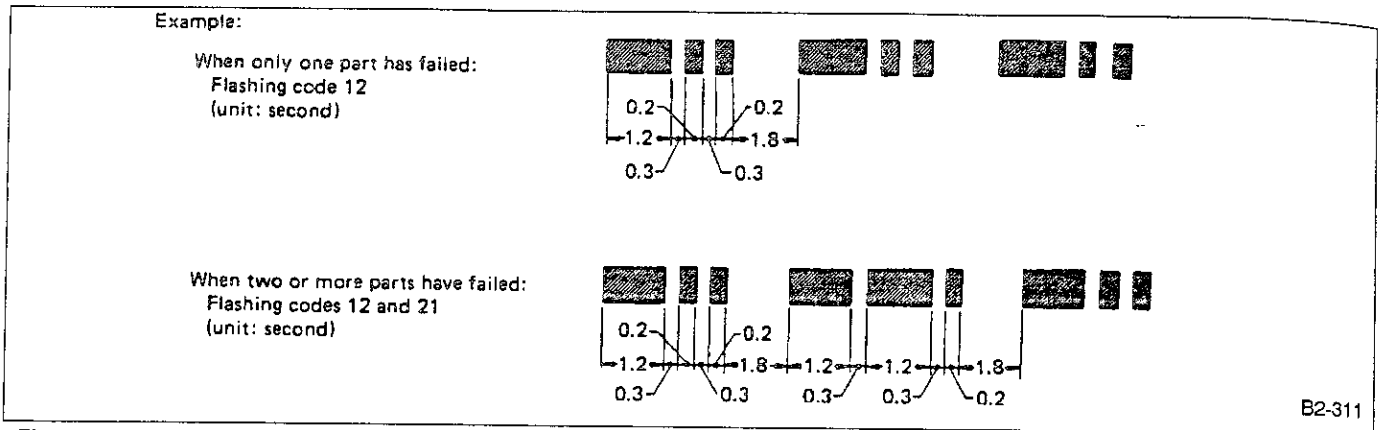
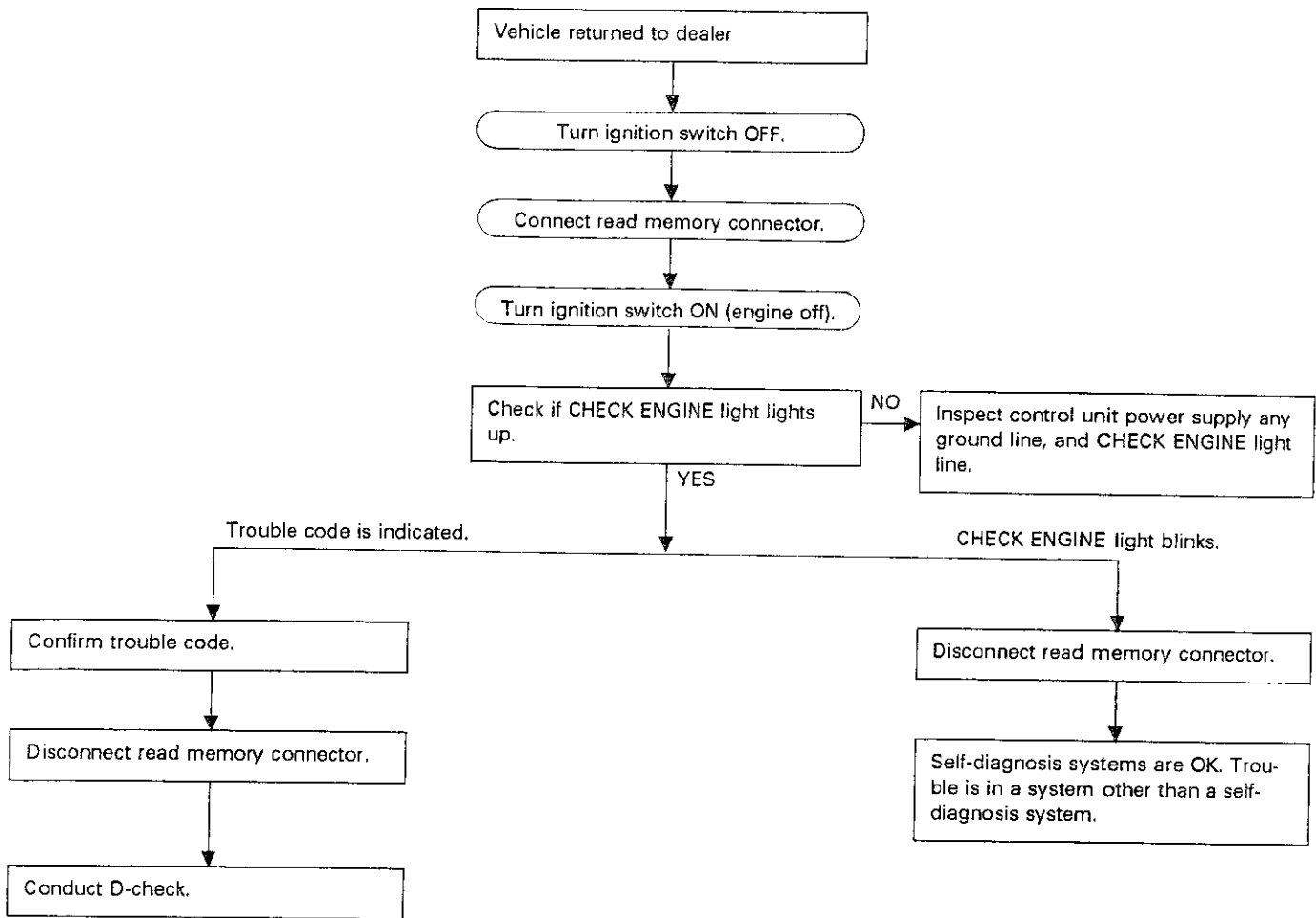
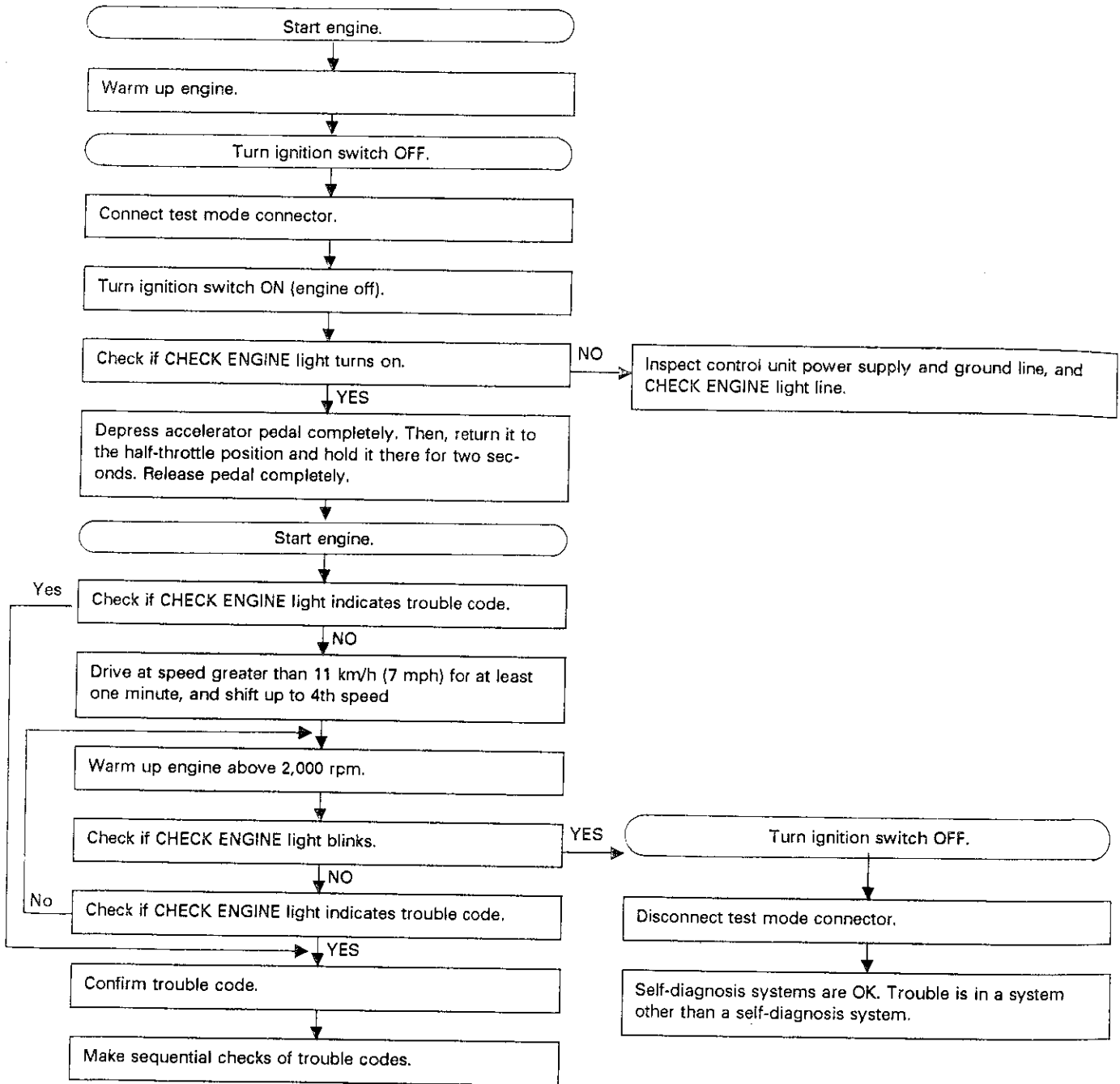


Fig. 72

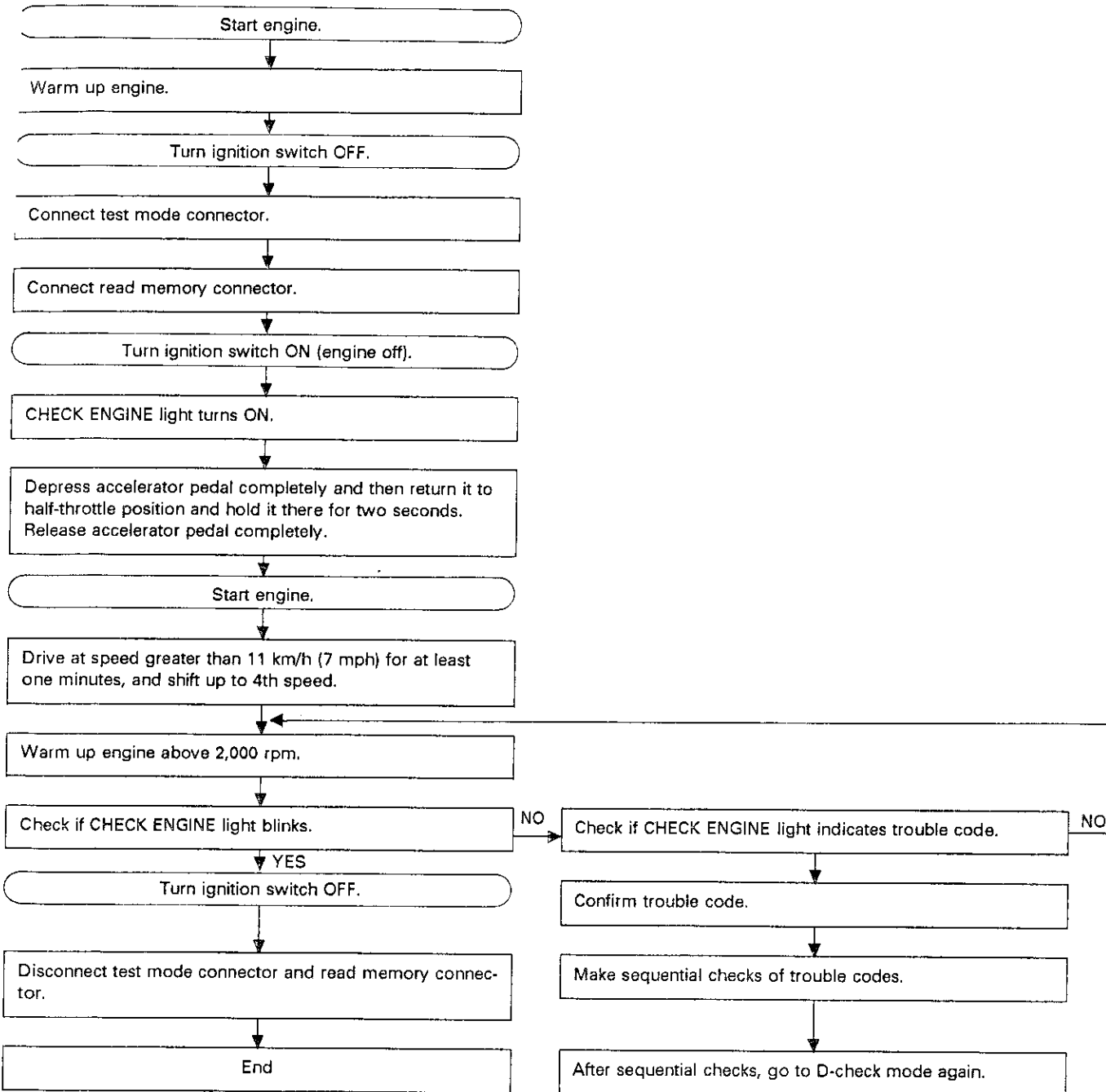
C: READ MEMORY MODE



D: D-CHECK MODE



E: CLEAR MEMORY MODE



4. Output Modes of Select Monitor

1. FUNCTION MODE

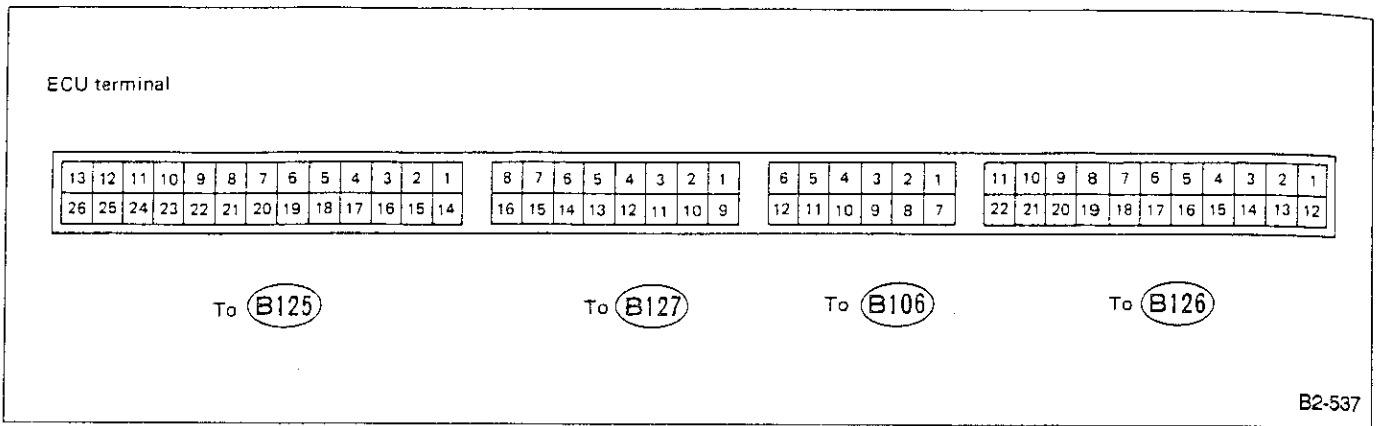
Applicable cartridge of select monitor: No. 498348800

MODE	Contents	Abbr.	Unit	Contents of display
F00	PROM ID Number	YEAR	—	Model year of vehicle to which select monitor is connected
F01	Battery Voltage	VB	V	Battery voltage supplied to control unit
F02	Vehicle Speed Sensor	VSP	m/h	Vehicle speed inputted from vehicle speed sensor
F03	Vehicle Speed Sensor	VSP	km/h	Vehicle speed inputted from vehicle speed sensor
F04	Engine Speed	EREV	rpm	Engine speed inputted from crank angle sensor
F05	Water Temp Sensor	TW	deg F	Coolant temperature inputted from water temperature sensor
F06	Water Temp Sensor	TW	deg C	Coolant temperature inputted from water temperature sensor
F07	Ignition Timing	ADVS	deg	Ignition timing determined by ECU in relation to signals sent from various sensors
F08	Air Flow Sensor	QA	V	Voltage inputted from air flow meter
F09	Load Data	LDATA	—	Engine load value determined by related sensor signals
F10	Throttle Sensor	THV	V	Voltage inputted from throttle position sensor
F11	Injector Pulse Width	TIM	mS	Duration of pulse flowing through injectors
F12	By-pass Air Control Valve	ISC	%	"Duty" ratio flowing through by-pass air control valve
F13	O ₂ Sensor	O ₂	V	Voltage outputted from O ₂ sensor
F15	O ₂ Max	O ₂ max	V	Maximum voltage outputted from O ₂ sensor
F16	O ₂ Min	O ₂ min	V	Minimum voltage outputted from O ₂ sensor
F19	ALPHA	ALPHA	%	AF correction ratio determined in relation to signal outputted from O ₂ sensor
F21	Knock Sensor	RTRD	deg	Ignition timing correction determined in relation to signal inputted from knock sensor
F22	Wastegate Control Valve	WGC	%	"Duty" ratio of wastegate control valve
F23	Atmospheric Pressure	BARO.P	mm Hg	Atmospheric pressure input from pressure sensor
F24	Manifold Pressure	MANI.P	mmHg	Intake manifold pressure input from pressure sensor
FA0	ON ↔ OFF Signal	—	—	—
FA1	ON ↔ OFF Signal	—	—	—
FA2	ON ↔ OFF Signal	—	—	—
FA3	ON ↔ OFF Signal	—	—	—
FB0	Trouble Code	DIAG	—	Trouble code in U- or D-check mode
FB1	Trouble Code	DIAG	—	Trouble code in Read Memory mode
FC0	Clear Memory	—	—	(Used to clear memory)

2. ON ↔ OFF SIGNAL LIST

MODE	LED No.	Contents	Display	LED "ON" requirements
FA0	1	Ignition SW	IG	Ignition switch "ON"
	3	Test Mode	UD	Test mode connector connected
	4	Read Memory	RM	Read-memory connector connected
	7	Neutral SW	NT	Neutral switch "ON"
FA1	1	Idle SW	ID	Idle switch "ON"
	2	A/C SW	AC	Air conditioner switch "ON"
	3	A/C Relay	AR	Air conditioner relay "ON"
	4	Radiator Fan	RF	Radiator fan in operation
	6	Fuel Pump Relay	FP	Fuel pump relay in operation
	7	Canister Solenoid	CN	Canister purge "ON"
FA2	8	Knock Sensor	KS	Engine knocks occur
	1	Intercooler pump control	MC	Pump rotates at high speed
	2	Intercooler pump resistor	IC	Pump rotates at low speed
FA3	3	Pressure exchange solenoid valve	BR	Atmospheric pressure is being measured (Solenoid "ON")
	10	O ₂ Monitor	O ₂	A/F ratio is rich

5. Control Unit I/O Signal



B2-537

Fig. 73

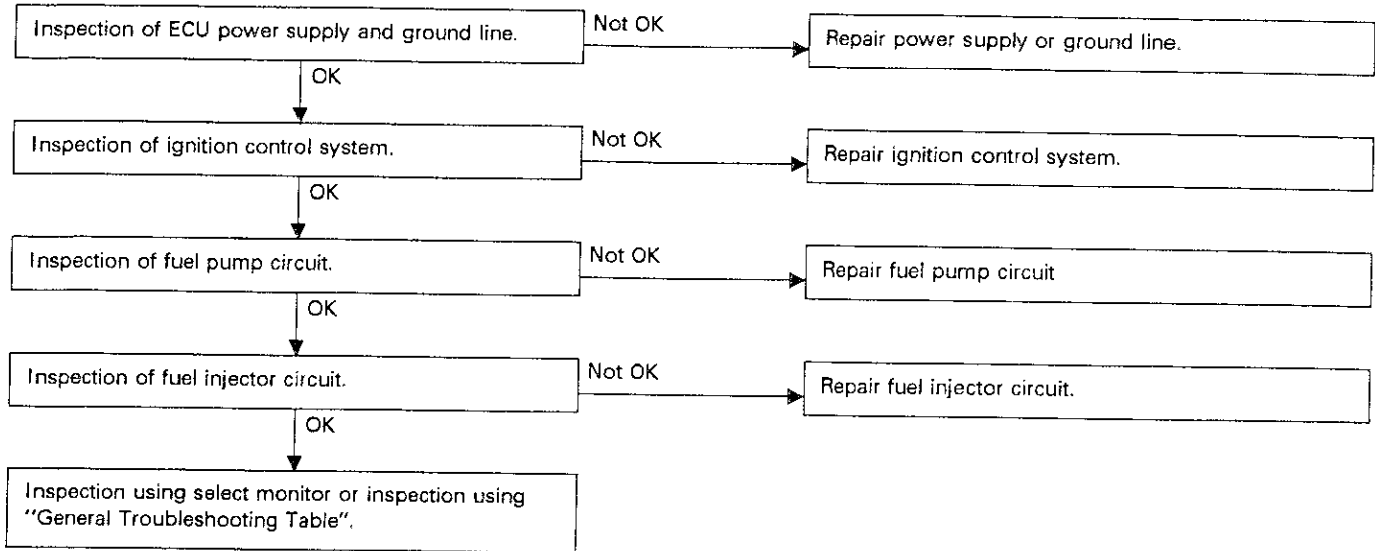
Content	Con- nector No.	Ter- minal No.	Signal (V)			Note	
			Ig SW		Engine ON (Idling)		
			OFF	ON (Engine OFF)			
Crank angle sensor	Signal (+)	B106	4	-	0	*	*Sensor output waveform
	Signal (-)	B106	5	-	0	0	-
	Shield	B106	6	-	0	0	-
Cam angle sensor	Signal (+)	B127	1	-	0	*	*Sensor output waveform
	Signal (-)	B127	2	-	0	0	-
	Shield	B127	3	-	0	0	-
Air flow sensor	Power supply	B126	8	-	10 - 13	13 - 14	-
	Signal	B126	9	-	0 - 0.3	0.8 - 1.2	-
	GND	B126	10	-	0	0	-
Throttle sensor	Signal	B106	2	-	Fully closed: 4.7 Fully opened: 0.9	Fully closed: 4.7 Fully opened: 0.9	-
	Power supply	B106	3	-	5	5	-
	GND	B106	1	-	0	0	-
O ₂ sensor	Signal	B126	6	-	0.6	Rich mixture: 0.7 - 1.0 Lean mixture: 0 - 0.2	
	Shield	B126	17	-	0	0	-
Knock sensor	Signal	B127	5	-	3 - 4	3 - 4	-
	Shield	B127	4	-	0	0	-
Water temperature sensor	B126	7	0	0.7 - 1.5	0.7 - 1.5	*After warm-up	
Vehicle speed sensor 2	B106	11	-	0 or 5	0 or 5	"5" and "0" are repeatedly displayed when vehicle is driven.	
Pressure sensor	Signal	B126	4	-	2.4 ↔ 2.7	1.4 - 1.6	-
	Power supply	B126	3	-	5	5	-
	GND	B126	21	-	0	0	-
Idle switch	B127	6	-	ON:0, OFF:5	ON:0, OFF:5	-	
Starter switch	B127	10	-	0	0	Cranking: 10 to 14	
Air conditioner switch	B127	9	-	ON:10 - 13, OFF:0	ON:13 - 14, OFF:0	-	
Ignition switch	B106	12	0	10 - 13	13 - 14	-	
Neutral switch	B106	10	-	N Position: 7 Other: 0	N Position: 7 Other: 0	-	
Test mode connector	B127	13	-	7	7	When connected: 0	
Read memory connector	B127	12	-	7	7	When connected: 0	
AT/MT identification	B126	20	-	7	7	-	

Content	Con- nector No.	Ter- minal No.	Signal (V)			Note
			Ig SW		Engine ON (Idling)	
			OFF	ON (Engine OFF)		
Back-up power supply	B126	15	10 - 13	10 - 13	13 - 14	-
Control unit power supply	B126	2	0	10 - 13	13 - 14	-
	B126	13	0	10 - 13	13 - 14	-
Ignition control	#1	B125	10	-	0	-
	#2	B125	9	-	0	-
	#3	B125	8	-	0	-
	#4	B125	7	-	0	-
Fuel injector	#1	B125	13	10 - 13	10 - 13	13 - 14
	#2	B125	12	10 - 13	10 - 13	13 - 14
	#3	B125	11	10 - 13	10 - 13	13 - 14
	#4	B125	26	10 - 13	10 - 13	13 - 14
By-pass air control solenoid valve	OPEN end	B125	2	-	8 - 9	9 - 10
	CLOSE end	B125	1	-	6 - 7	6 - 7
Fuel pump relay control	B125	23	-	ON: 0 OFF: 10 - 13	0	-
Air conditioner cut relay control	B125	22	-	ON: 0 Off: 10 - 13	ON: 0 OFF: 13 - 14	-
Radiator fan control	B125	17	-	ON: 0 OFF: 10 - 13	ON: 0 OFF: 13 - 14	-
Self-shutoff control	B125	5	-	10 - 13	13 - 14	-
Intercooler pump resistor exchange signal	B125	4	-	10 - 13	13 - 14	-
Wastegate control	B125	3	-	10 - 13	13 - 14	-
Intercooler pump control	B126	12	-	0.6	0	-
Trouble code output	B106	15	-	-	-	-
CHECK ENGINE light	B125	19	-	1, max.	-	Light "ON": 1, max. Light "OFF": 10 - 14
Pressure exchange solenoid valve	B125	20	-	ON: 0 OFF: 10 - 13	ON: 0 OFF: 13 - 14	-
Engine tachometer output	B127	16	-	-	-	-
Canister purge control	B125	6	-	ON: 0 OFF: 10 - 13	ON: 0 OFF: 13 - 14	-
GND (sensors)	B126	21	-	0	0	-
GND (injectors)	B125	24	-	0	0	-
	B125	25	-	0	0	-
Ignition system	B125	15	-	0	0	-
GND (power supply)	B125	14	-	0	0	-
GND (control systems)	B126	11	-	0	0	-
	B126	22	-	0	0	-
Select Monitor Signal	B127	8	-	-	-	-
	B127	7	-	-	-	-

6. Troubleshooting for Engine Starting Failure

A: BASIC TROUBLESHOOTING CHART

When engine cranks but does not start, troubleshoot in accordance with the following chart.



B: CONTROL UNIT POWER SUPPLY AND GROUND LINE

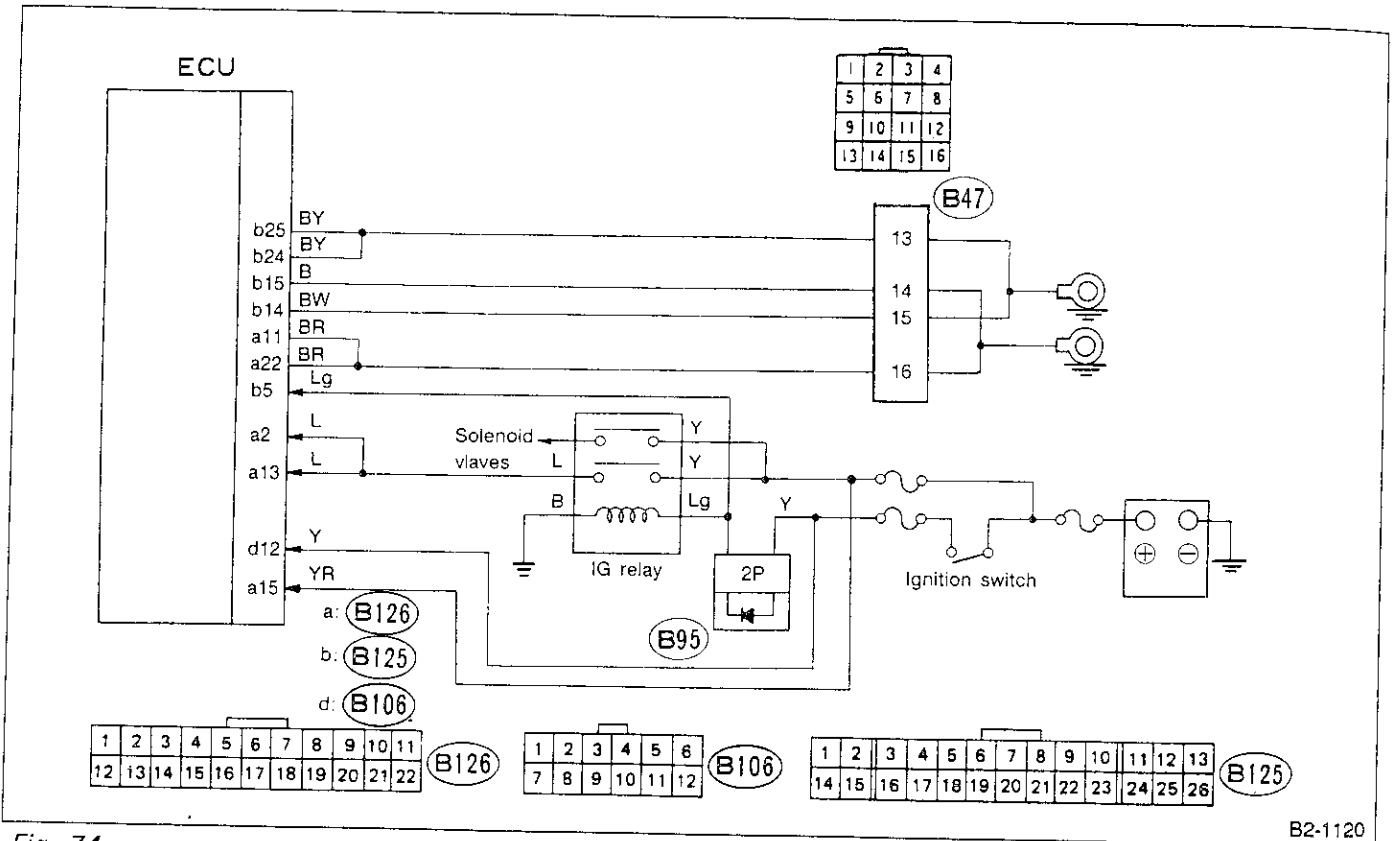
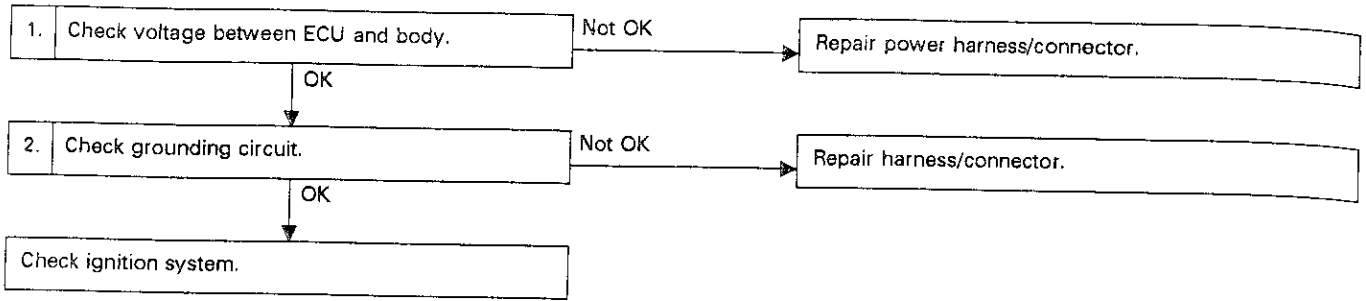


Fig. 74

B2-1120

1. CHECK VOLTAGE BETWEEN ECU AND BODY.

- 1) Turn the ignition switch to "ON".
- 2) Measure voltage between ECU connector terminals and body.

Connector & Terminal/Specified voltage:

- (B106) No. 12 — Body/10 V, min.
- (B126) No. 15 — Body/10 V, min.
- (B126) No. 2 — Body/10 V, min.
- (B126) No. 13 — Body/10 V, min.

2. CHECK GROUNDING CIRCUIT.

- 1) Disconnect ECU connector.
- 2) Check continuity between ECU connector terminals and body.

Connector & Terminal/Specified resistance:

- (B125) No. 24 — Body/0 Ω
- (B125) No. 25 — Body/0 Ω
- (B125) No. 14 — Body/0 Ω
- (B125) No. 15 — Body/0 Ω
- (B126) No. 11 — Body/0 Ω
- (B126) No. 22 — Body/0 Ω

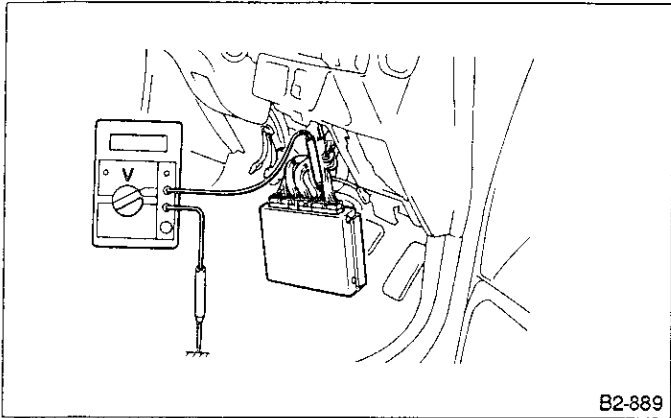


Fig. 75

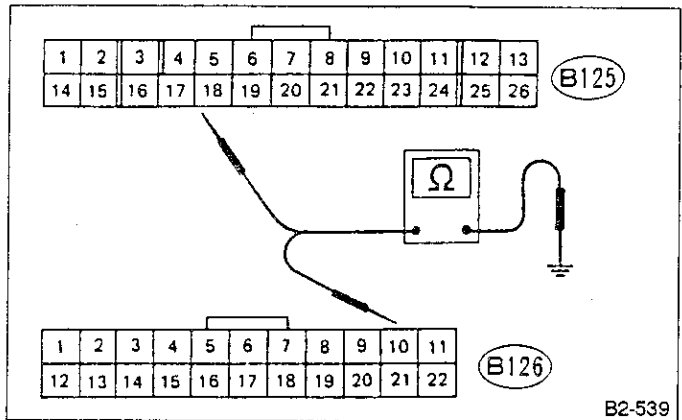


Fig. 76

C: IGNITION CONTROL SYSTEM

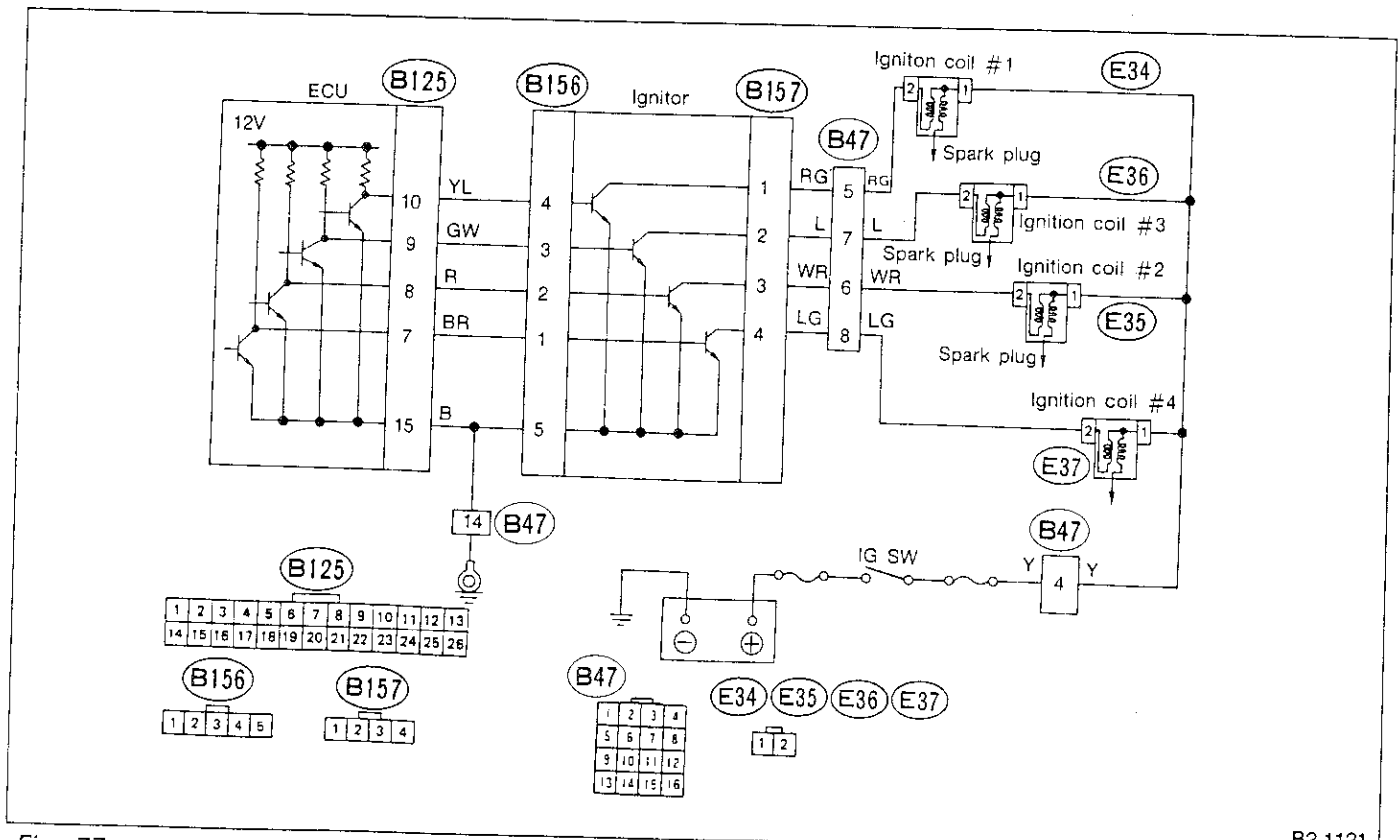
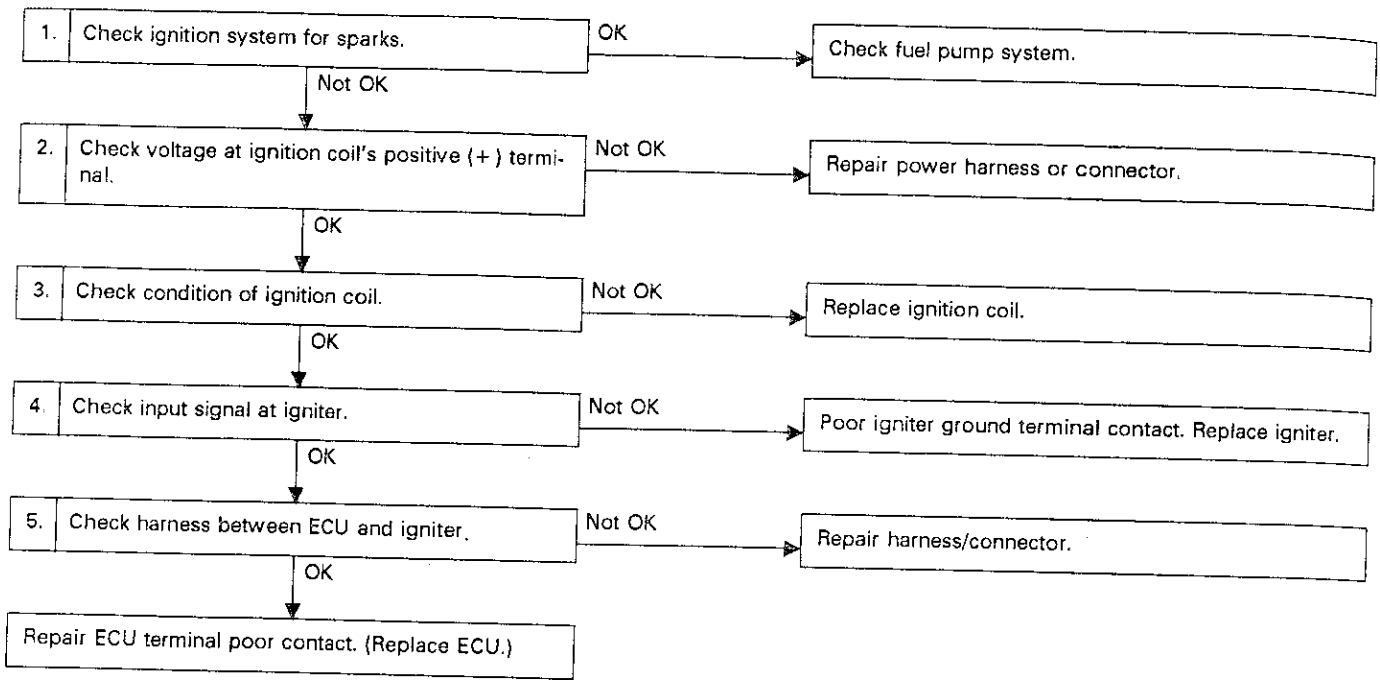


Fig. 77

B2-1121

CHECK IGNITION SYSTEM FOR SPARKS.

- 1) Prepare test spark plug and IG coil.
- 2) Disconnect injector connectors for four cylinders.
- 3) Disconnect IG coil connectors and connect test IG coil to one of the IG coil connectors.
- 4) Install test spark plug to test IG coil. While cranking engine, ground thread portion of test spark plug to engine body (GND) to make sure sparks occur.
- 5) Perform the above spark test for the remaining cylinders using procedures described in steps 3) and 4).

CHECK VOLTAGE AT IGNITION COIL'S POSITIVE (+) TERMINAL.

- 1) Turn ignition switch to "ON".
- 2) Measure voltage between positive terminal of ignition coil connector and body.

Connector & Terminal/Specified voltage:

- (E34) No. 1 — Body/10 V min.
- (E35) No. 1 — Body/10 V min.
- (E36) No. 1 — Body/10 V min.
- (E37) No. 1 — Body/10 V min.

4) Check IG coil's secondary winding.

If current flows with IG coil connected as shown in figure below, secondary winding continuity checks out O.K.

Connector & Terminal/Specified current value:

- No. 1 — Secondary terminal/Approx. 0.32 mA

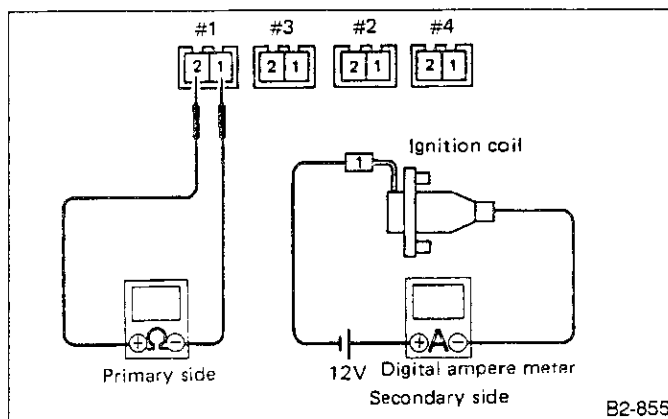


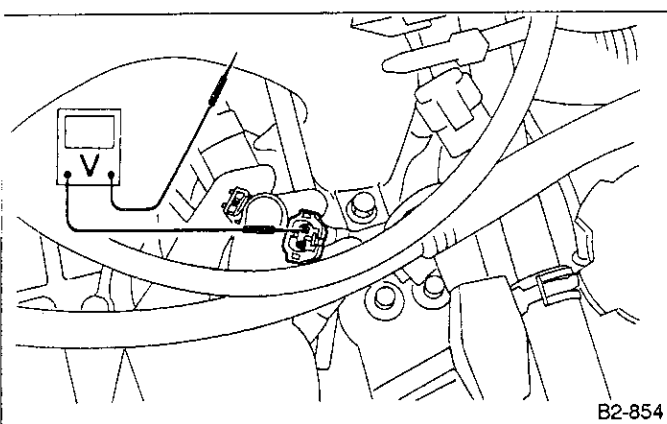
Fig. 79

4. CHECK INPUT SIGNAL AT IGNITER.

Check if voltage varies synchronously with engine revolution when cranking, while monitoring voltage between igniter connector and body.

Connector & Terminal/Specified resistance:

- (B156) No. 1 — Body/0.1 V min.
- (B156) No. 2 — Body/0.1 V min.
- (B156) No. 3 — Body/0.1 V min.
- (B156) No. 4 — Body/0.1 V min.



B2-854

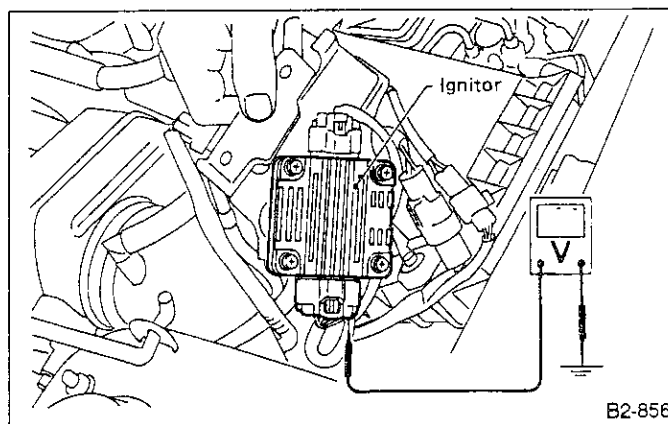
Fig. 78

3. CHECK CONDITION OF IGNITION COIL.

- 1) Disconnect IG coil connector.
- 2) Remove IG coil from engine.
- 3) Measure resistance of IG coil's primary winding.

Connector & Terminal/Specified resistance:

- No. 1 — No. 2/0.68 — 0.83 Ω



B2-856

Fig. 80

5. CHECK HARNESS BETWEEN ECU AND IGNITER.

- 1) Disconnect ECU connector and igniter connector.
- 2) Check discontinuity between ECU- and igniter-connector terminals.

Connector & Terminal/Specified resistance:

- (B125) No. 10 — (B156) No. 4/0 Ω
- (B125) No. 9 — (B156) No. 3/0 Ω
- (B125) No. 8 — (B156) No. 2/0 Ω
- (B125) No. 7 — (B156) No. 1/0 Ω
- (B125) No. 15 — (B156) No. 5/0 Ω
- (B125) No. 15 — Body/0 Ω

- 3) Measure resistance between connector terminals and body to check shortcircuit.

Connector & Terminal/Specified resistance:

- (B156) No. 1 — Body/1 M Ω min.
- (B156) No. 2 — Body/1 M Ω min.
- (B156) No. 3 — Body/1 M Ω min.
- (B156) No. 4 — Body/1 M Ω min.

D: FUEL PUMP CIRCUIT

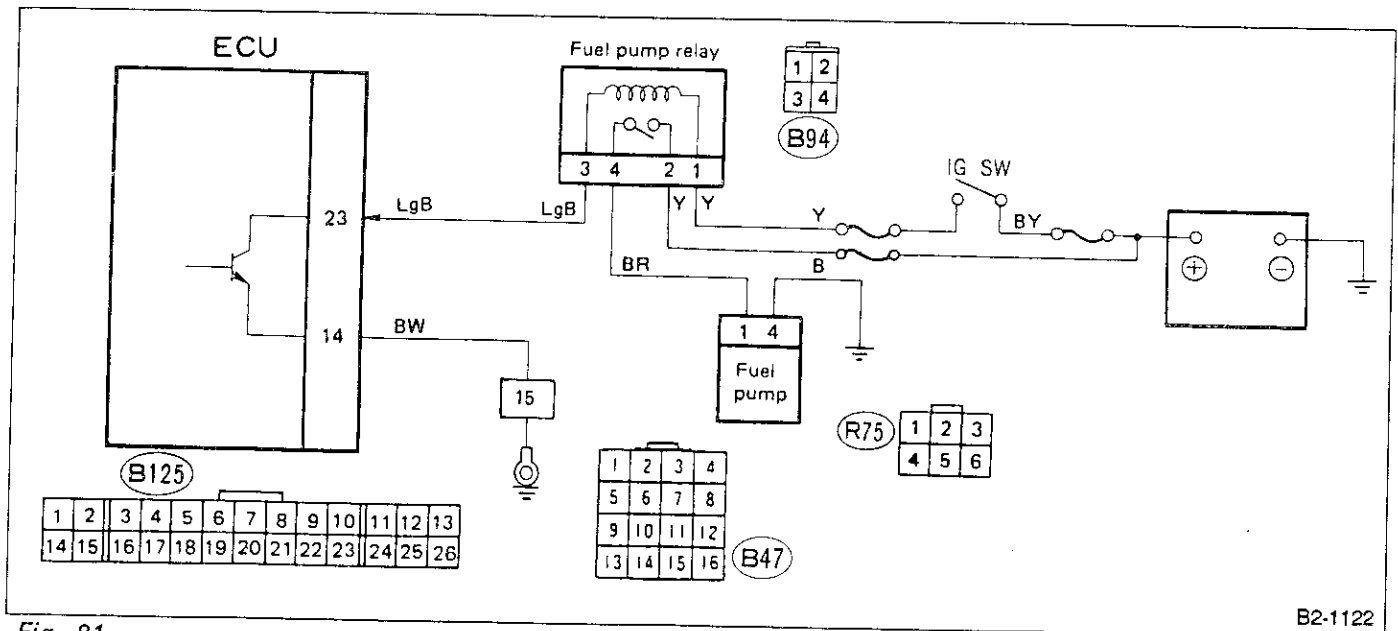
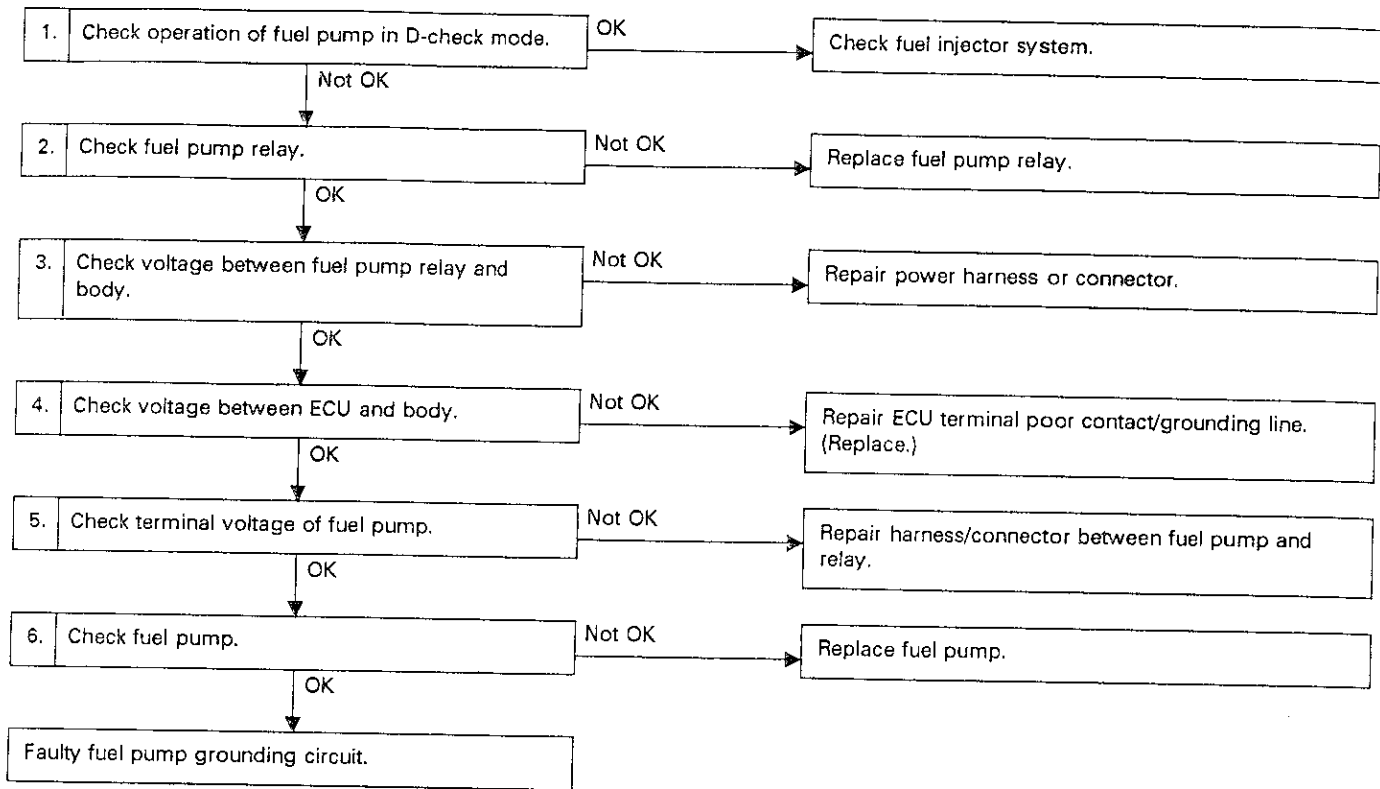


Fig. 81

B2-1122

1. CHECK OPERATION OF FUEL PUMP IN D-CHECK MODE.

- 1) Connect test-mode connector.
- 2) Turn ignition switch to "ON".
- 3) Check fuel pump for proper operation.

2. CHECK FUEL PUMP RELAY.

- 1) Disconnect fuel pump relay connector and remove relay from bracket.
- 2) Measure resistance of relay coil.

Terminal/Specified resistance:
No. 1 — No. 3/70 Ω

- 3) Connect battery (12 volts) to fuel pump relay coil terminals and check continuity between switching terminals. (Relay must issue clicks.)

Terminal/Specified resistance:
No. 2 — No. 4/0 Ω
(No. 1: Battery +)
(No. 3: Battery b -)

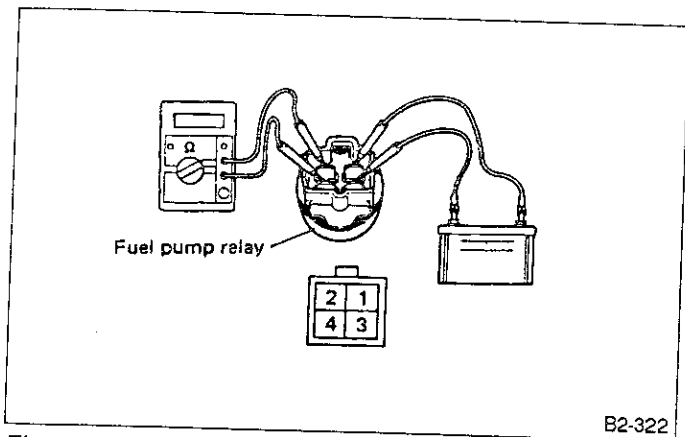


Fig. 82

3. CHECK VOLTAGE BETWEEN FUEL PUMP RELAY AND BODY.

- 1) Turn ignition switch to "OFF", and remove fuel pump relay. (Do not disconnect connector.)
- 2) Measure voltage between fuel pump relay connector and body.

Connector & Terminal/Specified voltage:
(B94) No. 1 — Body/10 V, min.

4. CHECK VOLTAGE BETWEEN ECU AND BODY.

- 1) Turn ignition switch to "ON".
- 2) Measure voltage when ignition switch is in "ON". Also measure voltage when cranking the engine.

Connector & Terminal/Specified voltage:
(B125) No. 23 — Body/
10 V, min. (Ignition ON)
0 V (when cranking the engine)

5. CHECK TERMINAL VOLTAGE OF FUEL PUMP.

- 1) Remove access lid of fuel pump located in trunk compartment and remove fuel pump connector.
- 2) Measure voltage between connector and body while cranking the engine.

Connector & Terminal/Specified voltage:
(R75) No. 1 — Body/10 V, min.

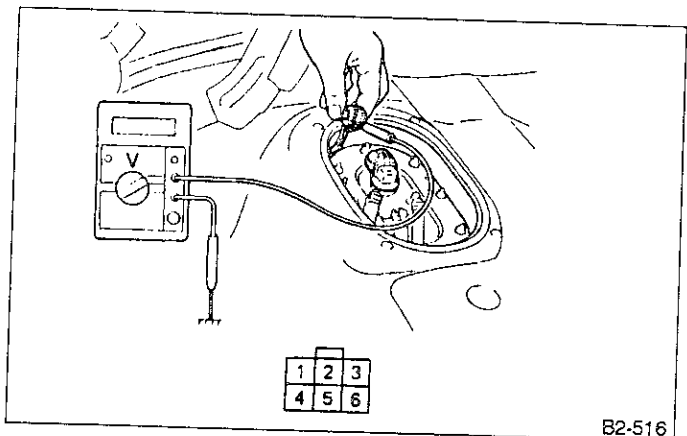


Fig. 83

6. CHECK FUEL PUMP.

- 1) Disconnect fuel pump connector.
- 2) Connect 12-volt battery to proper fuel pump connector terminal and GND terminal to check fuel pump operation.

Terminal:
No. 1 → Battery (+)
No. 4 → Battery b (-)

E: FUEL INJECTOR CIRCUIT

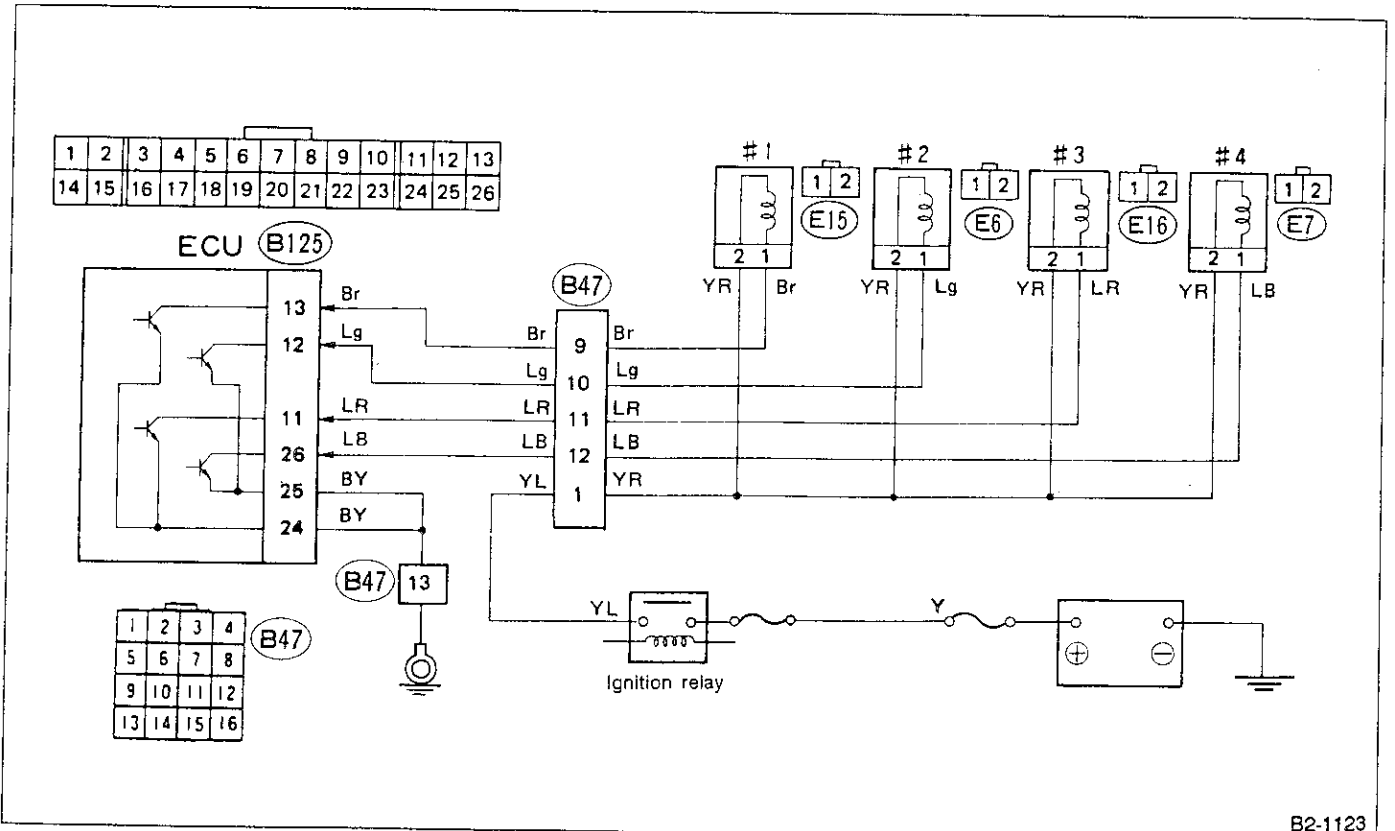
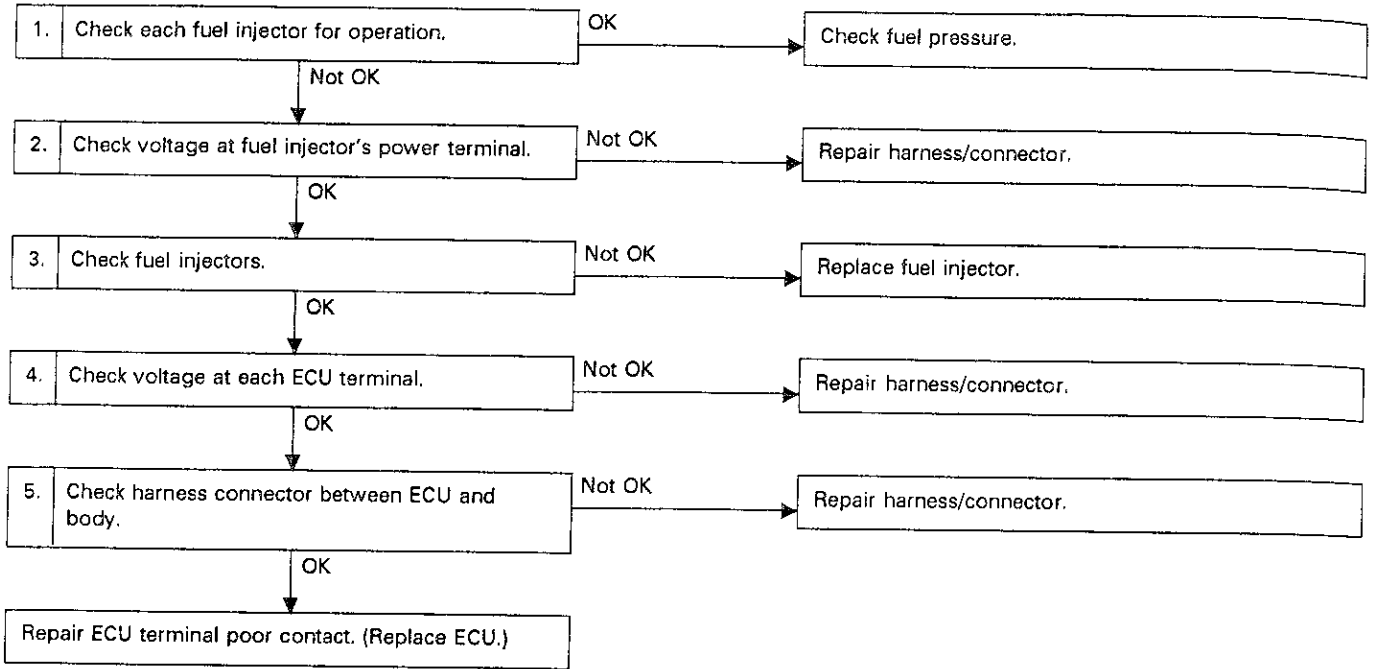


Fig. 84

B2-1123

1. CHECK EACH FUEL INJECTOR FOR OPERATION.

While cranking the engine, check that each fuel injector emits "operating" sound. Use a sound scope or attach a screwdriver to injector for this check.

2. CHECK VOLTAGE AT FUEL INJECTOR POWER TERMINAL.

- 1) Disconnect connector from injector.
- 2) Measure voltage between injector connector power terminal and body.

Connector & Terminal/Specified voltage:

- (E16) No. 2 — Body/10 V, min.
- (E6) No. 2 — Body/10 V, min.
- (E15) No. 2 — Body/10 V, min.
- (E7) No. 2 — Body/10 V, min.

3. CHECK FUEL INJECTORS.

- 1) Disconnect connector from injector.
- 2) Measure resistance between injector terminals.

Specified resistance:

11 ~ 12 Ω

4. CHECK VOLTAGE AT EACH ECU TERMINAL.

Measure voltage between each fuel injector terminal of ECU connector and body.

(Fuel injector connector is connected.)

Connector & Terminal/Specified voltage:

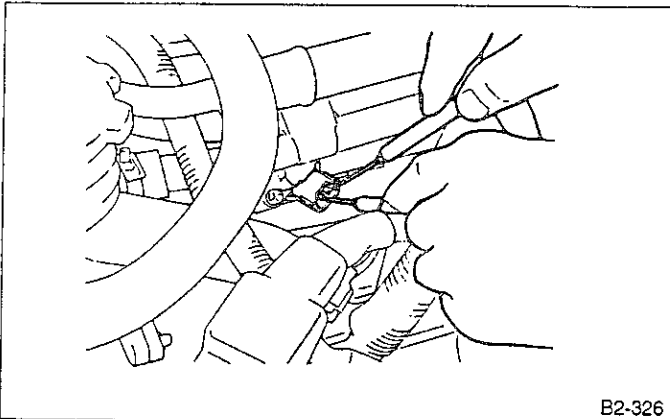
- (B125) No. 11 — Body/10 V, min.
- (B125) No. 12 — Body/10 V, min.
- (B125) No. 13 — Body/10 V, min.
- (B125) No. 26 — Body/10 V, min.

5. CHECK HARNESS CONNECTOR BETWEEN ECU AND BODY.

- 1) Disconnect connector from ECU.
- 2) Measure resistance between ECU connector and body.

Connector & Terminal/Specified resistance:

- (B125) No. 24 — Body/0 Ω
- (B125) No. 25 — Body/0 Ω



B2-326

Fig. 85

7. Troubleshooting Chart with Trouble Code

A: TROUBLE CODE (11) — CRANK ANGLE SENSOR —

CONTENT OF DIAGNOSIS:

No signal entered from crank angle sensor, but signal (corresponding to at least one rotation of crank) entered from cam angle sensor

TROUBLE SYMPTOM:

Engine stall Restarting impossible

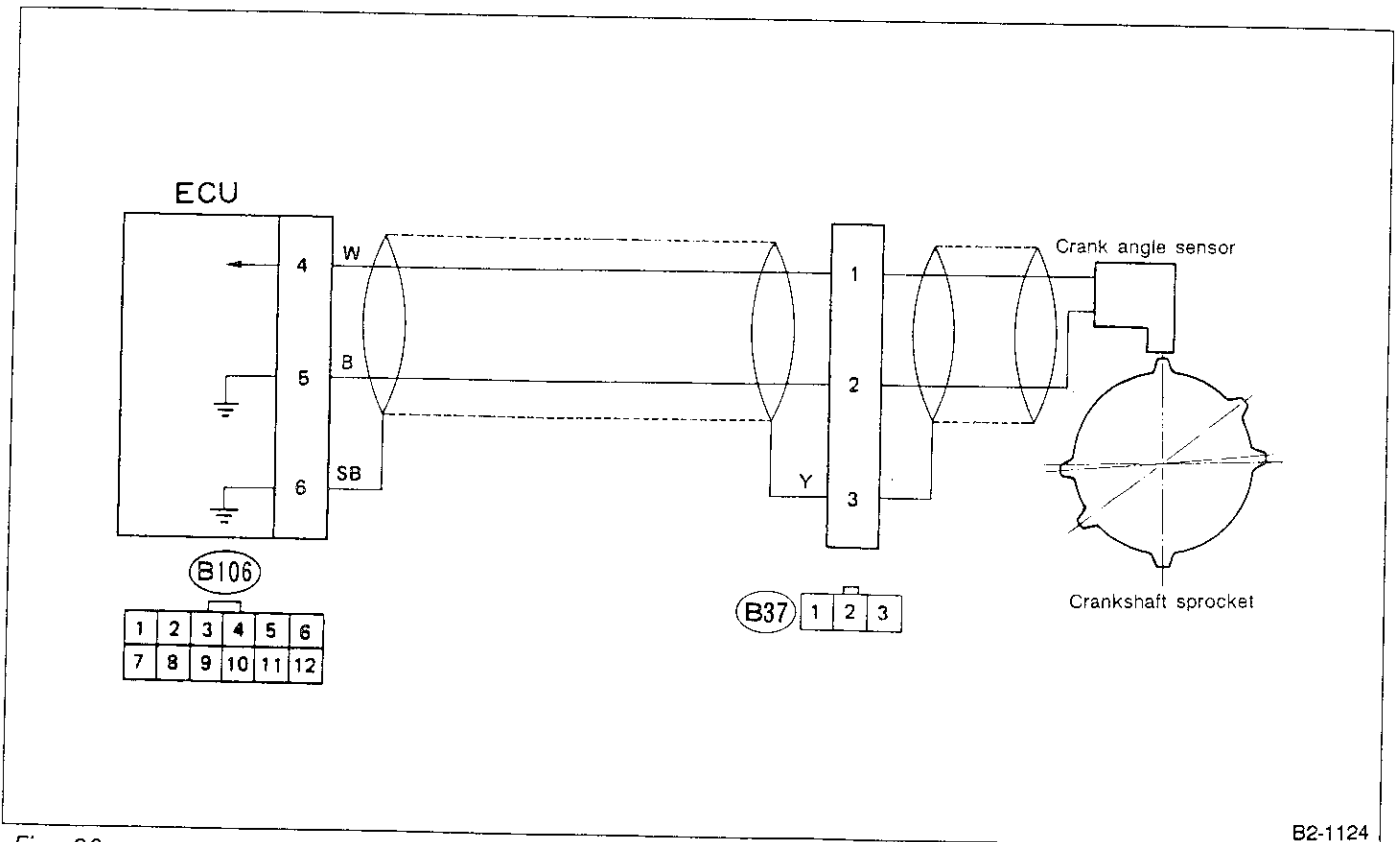
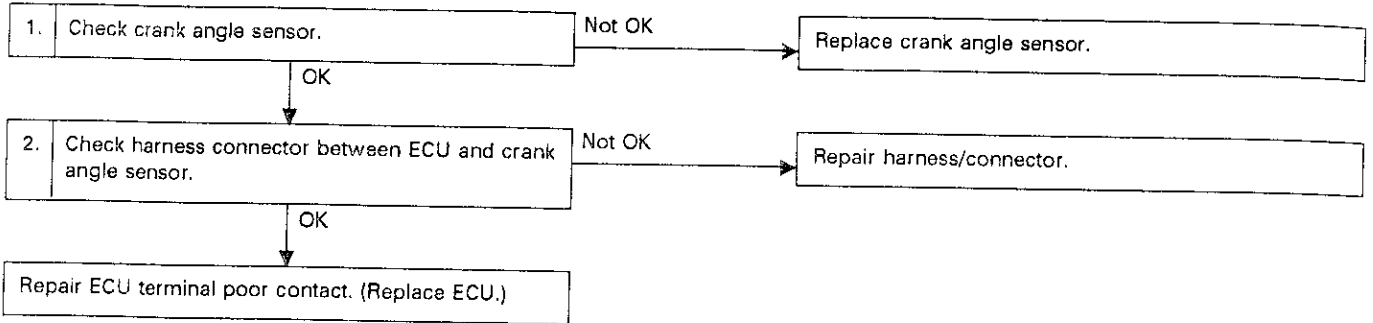


Fig. 86

B2-1124

1. CHECK CRANK ANGLE SENSOR.

- 1) Disconnect crank angle sensor connector.
- 2) Check if voltage varies synchronously with engine revolutions when cranking, while monitoring voltage between crank angle sensor connector terminals (AC 0.1 V, min.).

Terminal:

No. 1 — No. 2

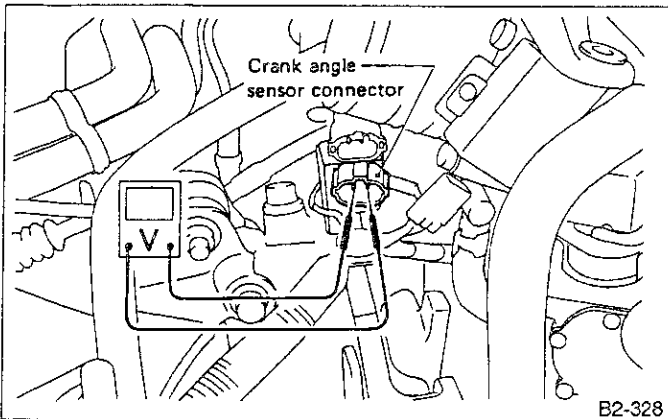


Fig. 87

2. CHECK HARNESS CONNECTOR BETWEEN ECU AND CRANK ANGLE SENSOR.

- 1) Disconnect connectors from ECU and crank angle sensor.
- 2) Measure resistance between ECU connector and angle sensor connector.

Connector & Terminal/Specified resistance:

- (B106) No. 4 — (B37) No. 1/0 Ω
- (B106) No. 5 — (B37) No. 2/0 Ω
- (B106) No. 6 — (B37) No. 3/0 Ω

- 3) Measure resistance between crank angle sensor connector and body.

Connector & Terminal/Specified resistance:

- (B37) No. 1 — Body/1 MΩ min.
- (B37) No. 2 — Body/1 MΩ min.

- 4) Connect ECU connector and measure resistance between crank angle sensor sealed terminal and body.

Connector & Terminal/Specified resistance:

- (B37) No. 3 — Body/0 Ω

- 5) Disconnect cam angle sensor connector and measure resistance between sealed terminal and body.

Connector & Terminal/Specified resistance:

- (B39) No. 3 — Body/0 Ω

• SELECT MONITOR FUNCTION MODE

Mode: F04

Condition: Engine at idle

Specified Data: EREV F04
 900 ± 100 rpm
 (No load)

B: TROUBLE CODE (12) — STARTER SWITCH —

CONTENT OF DIAGNOSIS:
Abnormal signal emitted from ignition starter switch

TROUBLE SYMPTOM:
Failure of engine to start

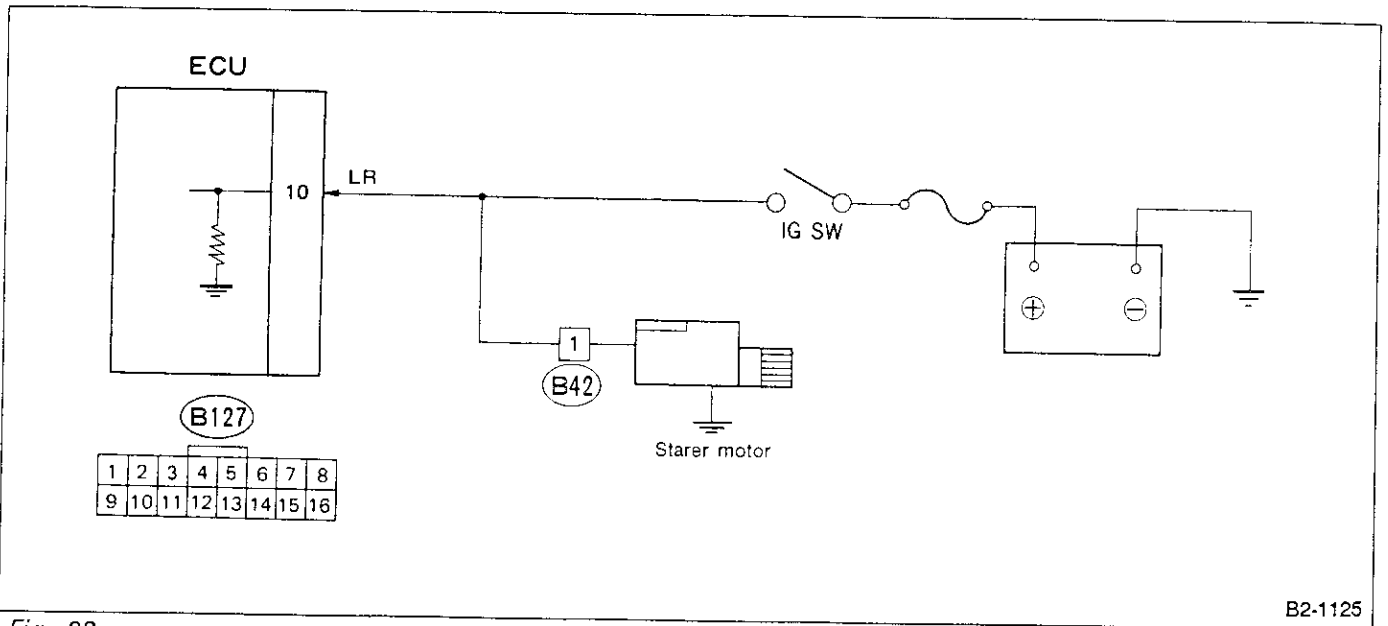
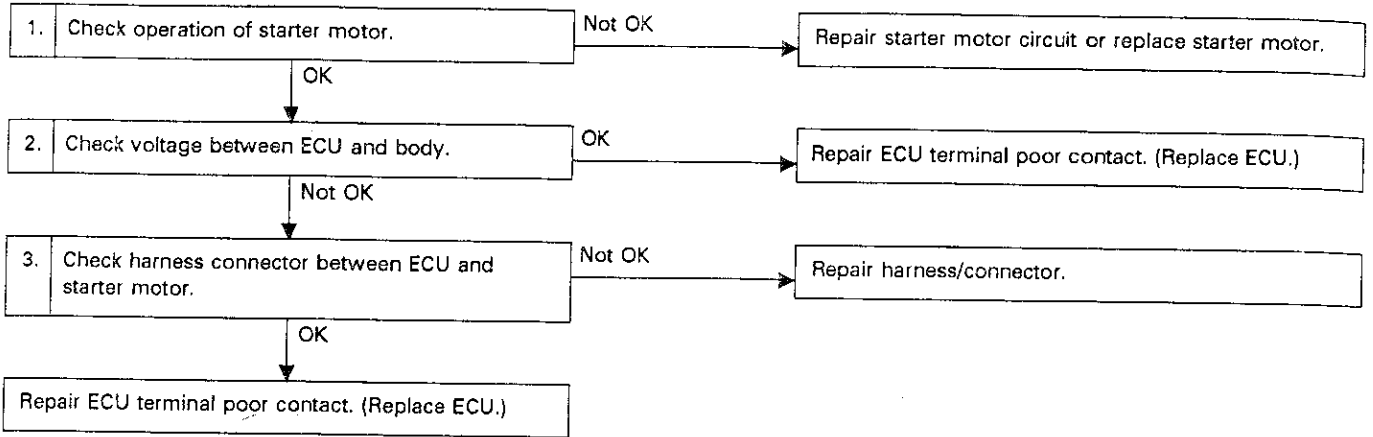


Fig. 88

B2-1125

1. CHECK OPERATION OF STARTER MOTOR.

Turn ignition switch to "ST" to ensure that starter motor functions.

2. MEASURE VOLTAGE BETWEEN ECU AND BODY.

Measure voltage between ECU connector terminal and body while cranking the engine.

Connector & Terminal/Specified voltage:
(B127) No. 10 — Body/9 — 10 V, min.

3. CHECK HARNESS CONNECTOR BETWEEN ECU AND STARTER MOTOR.

- 1) Disconnect connectors from ECU and starter motor.
- 2) Measure resistance between ECU connector and starter motor connector.

Connector & Terminal/Specified resistance:
(B127) No. 10 — (B42) No. 1/0 Ω

- 3) Measure resistance between starter motor connector and body.

Connector & Terminal/Specified resistance:
(B42) No. 1 — Body/1 M Ω min.

C: TROUBLE CODE (13) — CAM ANGLE SENSOR —

CONTENT OF DIAGNOSIS:

No signal entered from cam angle sensor, but signal (corresponding to at least two rotations of cam) entered from crank angle sensor

TROUBLE SYMPTOM:

Engine stall Failure of engine to start

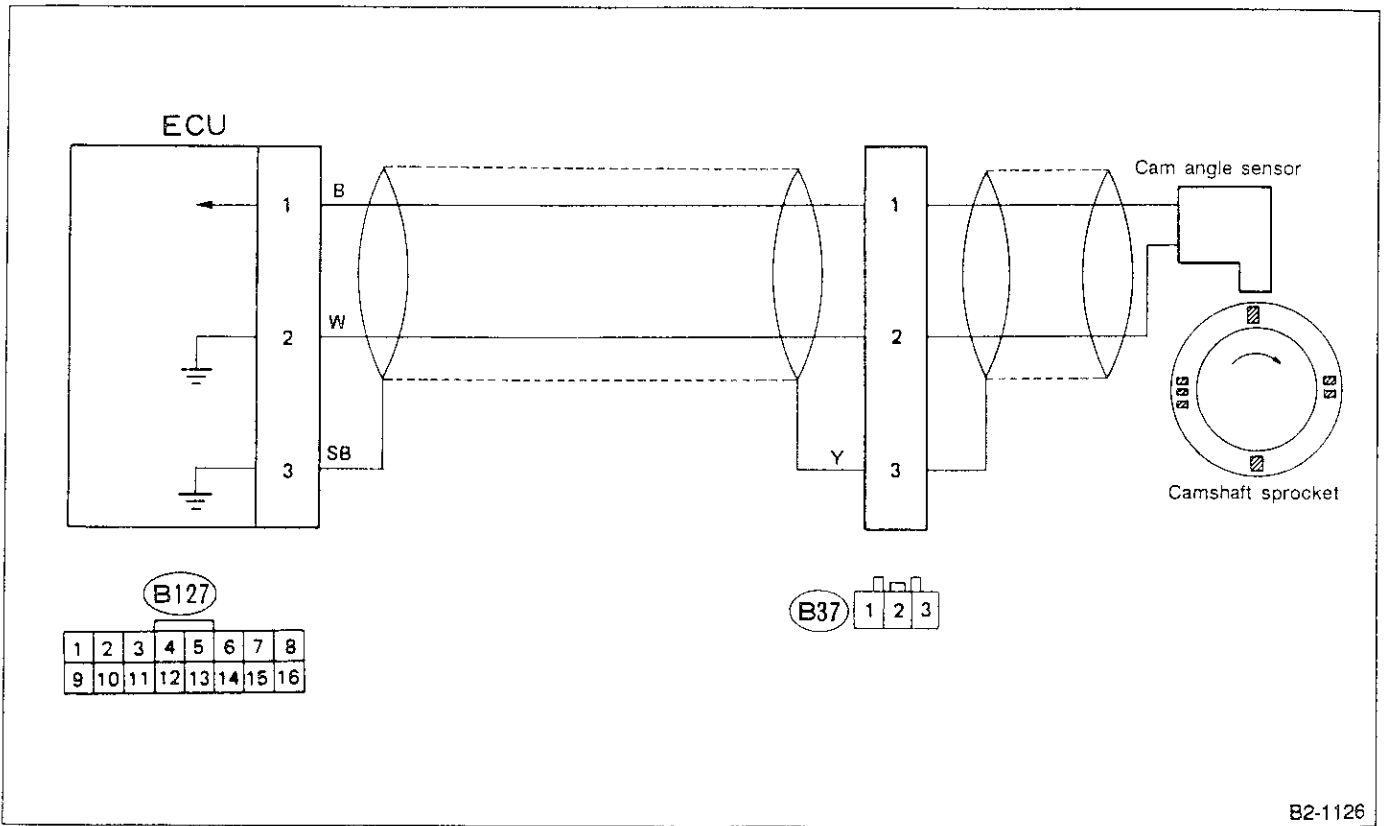
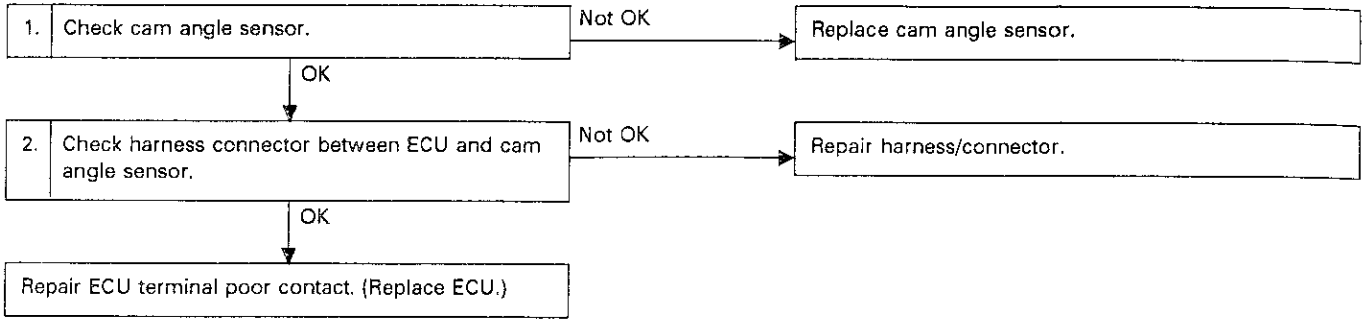


Fig. 89

1. CHECK CAM ANGLE SENSOR.

- 1) Disconnect cam angle sensor connector.
- 2) Check if voltage varies synchronously with engine revolutions when cranking, while monitoring voltage between cam angle sensor connector terminals (AC 0.1 V, min.).

Terminal :
No.1 — No.2

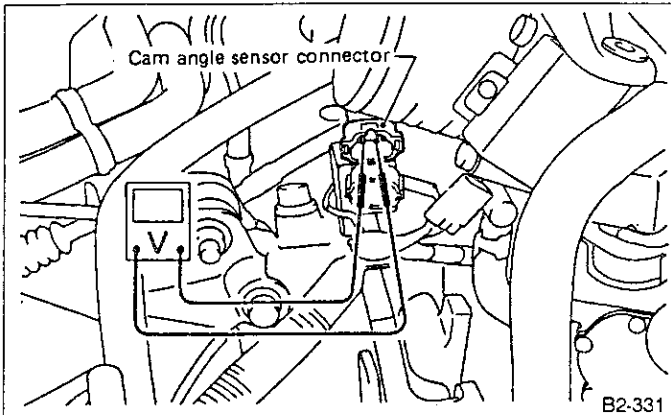


Fig. 90

2. CHECK HARNESS CONNECTOR BETWEEN ECU AND CAM ANGLE SENSOR.

- 1) Disconnect connectors from ECU and cam angle sensor.
- 2) Measure resistance between ECU connector and cam angle sensor connector.

Connector & Terminal/Specified resistance:
 (B127) No. 1 — (B39) No. 1/0 Ω
 (B127) No. 2 — (B39) No. 2/0 Ω
 (B127) No. 3 — (B39) No. 3/0 Ω

- 3) Measure resistance between cam angle sensor connector and body.

Connector & Terminal/Specified resistance:
 (B39) No. 1 — Body/1 MΩ min.
 (B39) No. 2 — Body/1 MΩ min.

- 4) Connect ECU connector and measure resistance between cam angle sensor sealed terminal and body.

Connector & Terminal/Specified resistance:
 (B39) No. 3 — Body/0 Ω

- 5) Disconnect crank angle sensor connector and measure resistance between sealed terminal and body.

Connector & Terminal/Specified resistance:
 (B37) No. 3 — Body/0 Ω

• **SELECT MONITOR FUNCTION MODE**

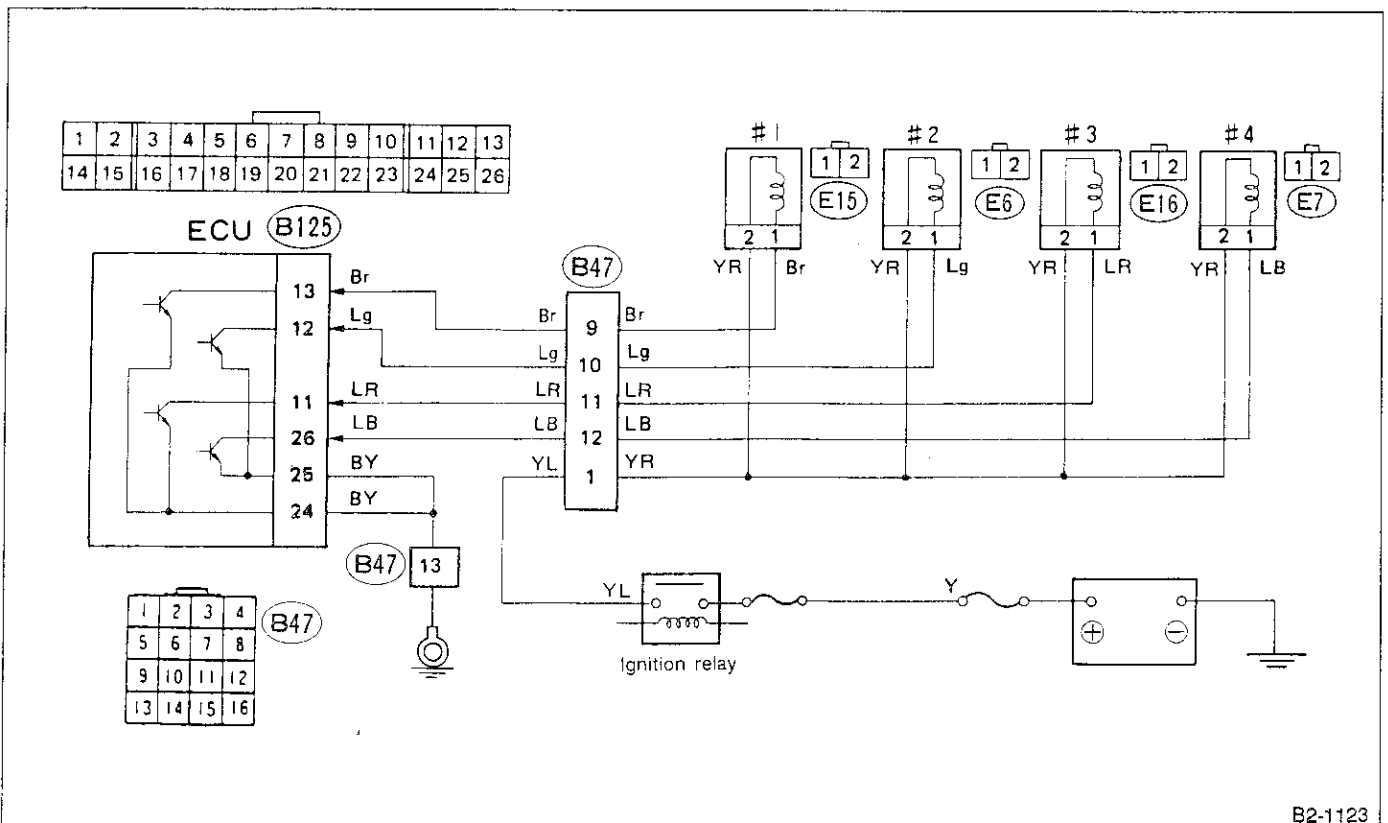
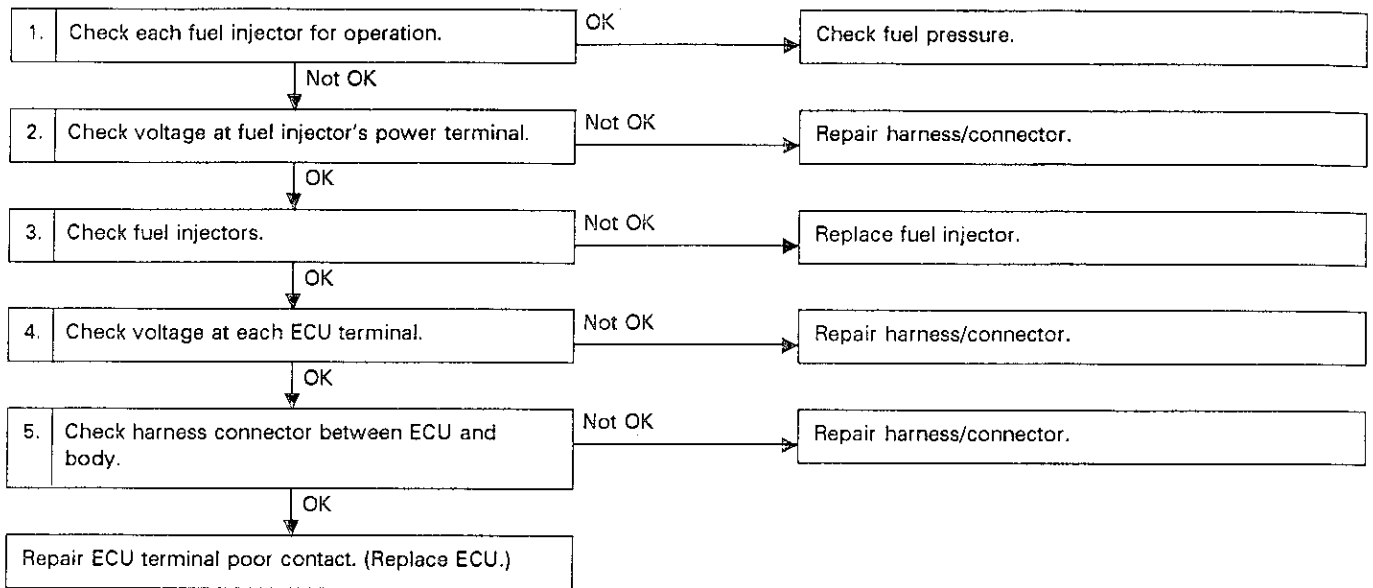
Mode: F04
 Condition: Engine at idle
 Specified Data: EREV F04
 900 ± 100
 (No load)

D: TROUBLE CODE (14, 15, 16, 17) — FUEL INJECTOR —

CONTENT OF DIAGNOSIS:
Fuel injector inoperative

TROUBLE SYMPTOM:

- Engine stall
- Erroneous idling
- Rough driving



B2-1123

Fig. 91

1. CHECK EACH FUEL INJECTOR FOR OPERATION.

While cranking the engine, check that each fuel injector emits "operating" sound. Use a sound scope or attach a screwdriver to injector for this check.

2. CHECK VOLTAGE AT FUEL INJECTOR POWER TERMINAL.

- 1) Disconnect connector from injector.
- 2) Measure voltage between injector connector power terminal and body.

Connector & Terminal/Specified voltage:

- (E16) No. 2 — Body/10 V, min.
- (E6) No. 2 — Body/10 V, min.
- (E15) No. 2 — Body/10 V, min.
- (E7) No. 2 — Body/10 V, min.

3. CHECK FUEL INJECTORS.

- 1) Disconnect connector from injector.
- 2) Measure resistance between injector terminals.

Specified resistance:

11 ~ 12 Ω

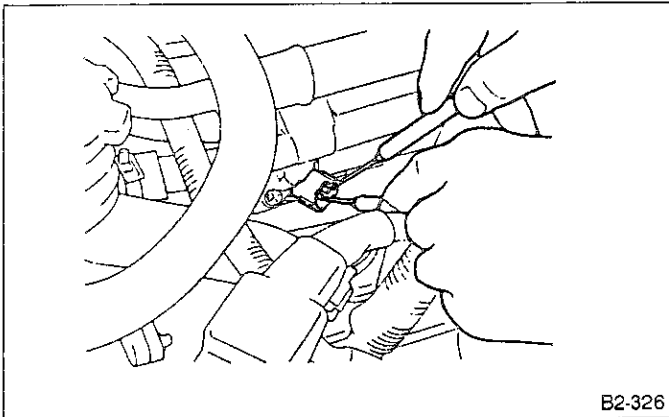


Fig. 92

4. CHECK VOLTAGE AT EACH ECU TERMINAL.

Measure voltage between each fuel injector terminal of ECU connector and body.

(Fuel injector connector is connected.)

Connector & Terminal/Specified voltage:

- (B125) No. 11 — Body/10 V, min.
- (B125) No. 12 — Body/10 V, min.
- (B125) No. 13 — Body/10 V, min.
- (B125) No. 26 — Body/10 V, min.

5. CHECK HARNESS CONNECTOR BETWEEN ECU AND BODY.

- 1) Disconnect connector from ECU.
- 2) Measure resistance between ECU connector and body.

Connector & Terminal/Specified resistance:

- (B125) No. 24 — Body/0 Ω
- (B125) No. 25 — Body/0 Ω

E: TROUBLE CODE (21) — WATER TEMPERATURE SENSOR —

CONTENT OF DIAGNOSIS:
Abnormal signal emitted from water temperature sensor

TROUBLE SYMPTOM:
 • Hard to start
 • Erroneous idling
 • Poor driving performance

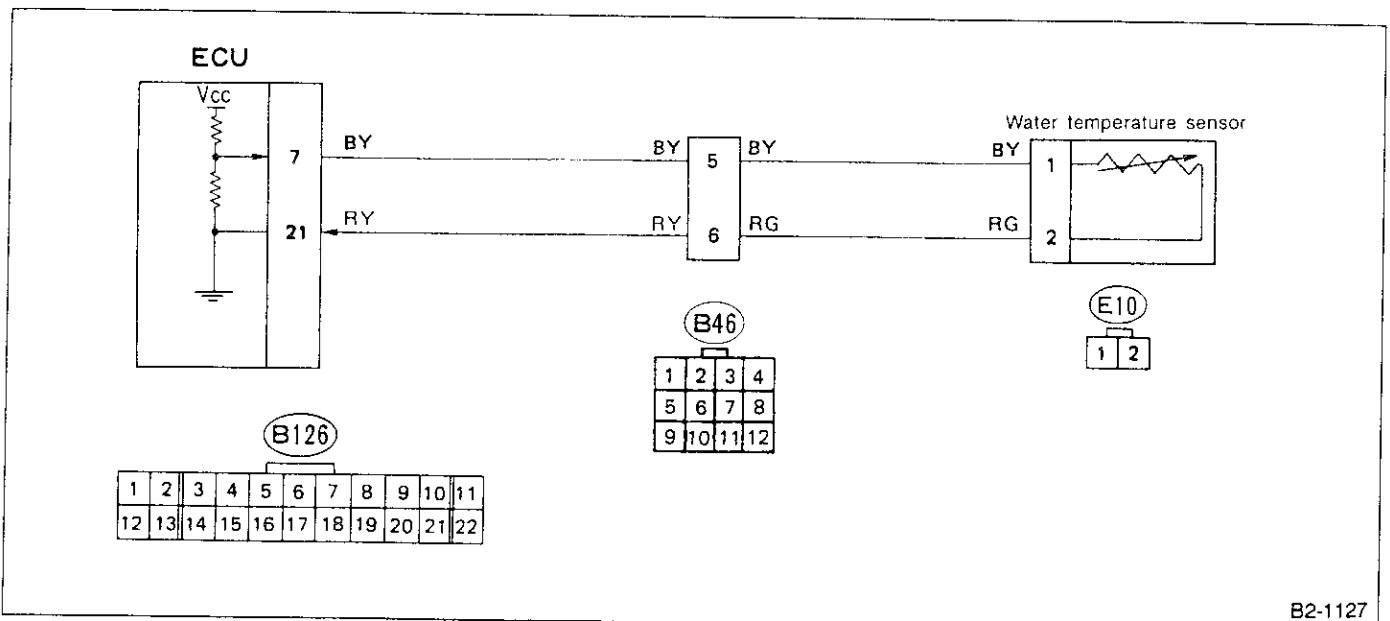
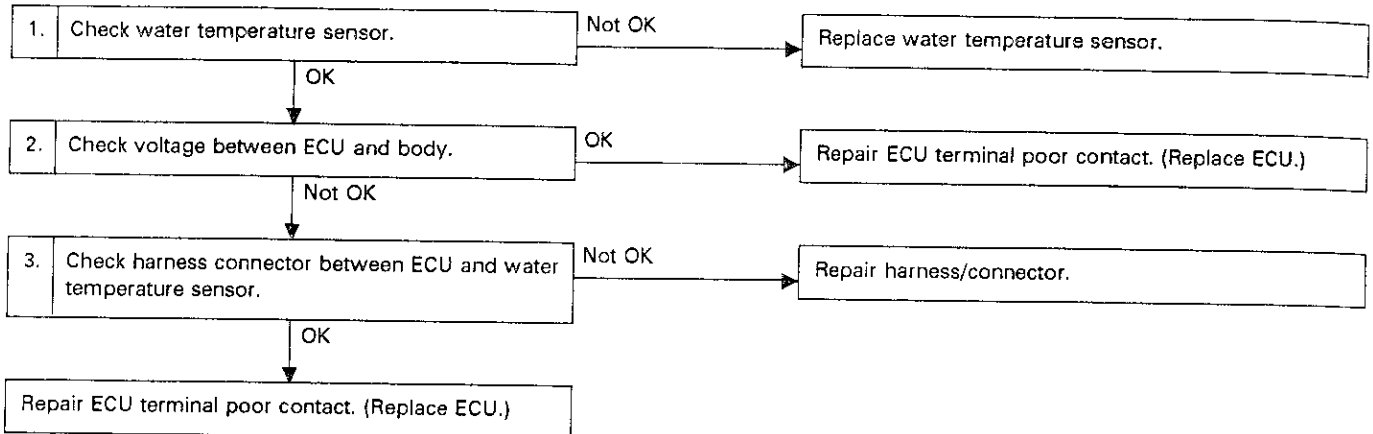


Fig. 93

B2-1127

1. CHECK WATER TEMPERATURE SENSOR.

- 1) Disconnect connector from water temperature sensor.
- 2) Measure resistance between water temperature sensor terminals.

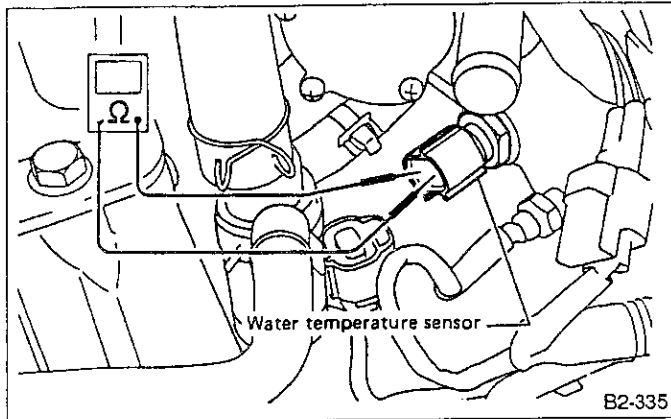


Fig. 94

Specified resistance:

- 2.0 — 3.0 kΩ [20°C (68°F)]
- 0.3 — 0.4 kΩ [80°C (176°F)]

2. CHECK VOLTAGE BETWEEN ECU AND BODY.

- 1) Connect water temperature sensor connector.
- 2) Turn ignition switch to "ON".
- 3) Measure voltage between ECU connector terminal and body.

Connector & Terminal/Specified voltage:

- (B126) No. 7 — Body/0.6 — 4.5 V

3. CHECK HARNESS CONNECTOR BETWEEN ECU AND WATER TEMPERATURE SENSOR.

- 1) Disconnect ECU connector and water temperature sensor connector.
- 2) Measure resistance between ECU connector and water temperature connector.

Connector & Terminal/Specified resistance:

- (B126) No. 7 — (E10) No. 1/0 Ω
- (B126) No. 21 — (E10) No. 2/0 Ω

- 3) Measure resistance between water temperature sensor connector and body.

Connector & Terminal/Specified resistance:

- (E10) No. 1 — Body/1 MΩ min.
- (E10) No. 2 — Body/1 MΩ min.

• **SELECT MONITOR FUNCTION MODE**

Mode: F06

Condition:

After warming up engine, engine at idle and radiator fan OFF.

Specified Data: TW F06
80 — 95 deg C

F05 = Water temperature signal (TW): To be indicated in "deg F"

F: TROUBLE CODE (22) — KNOCK SENSOR —

CONTENT OF DIAGNOSIS:
Abnormal voltage produced in knock sensor

TROUBLE SYMPTOM:
Poor driving performance

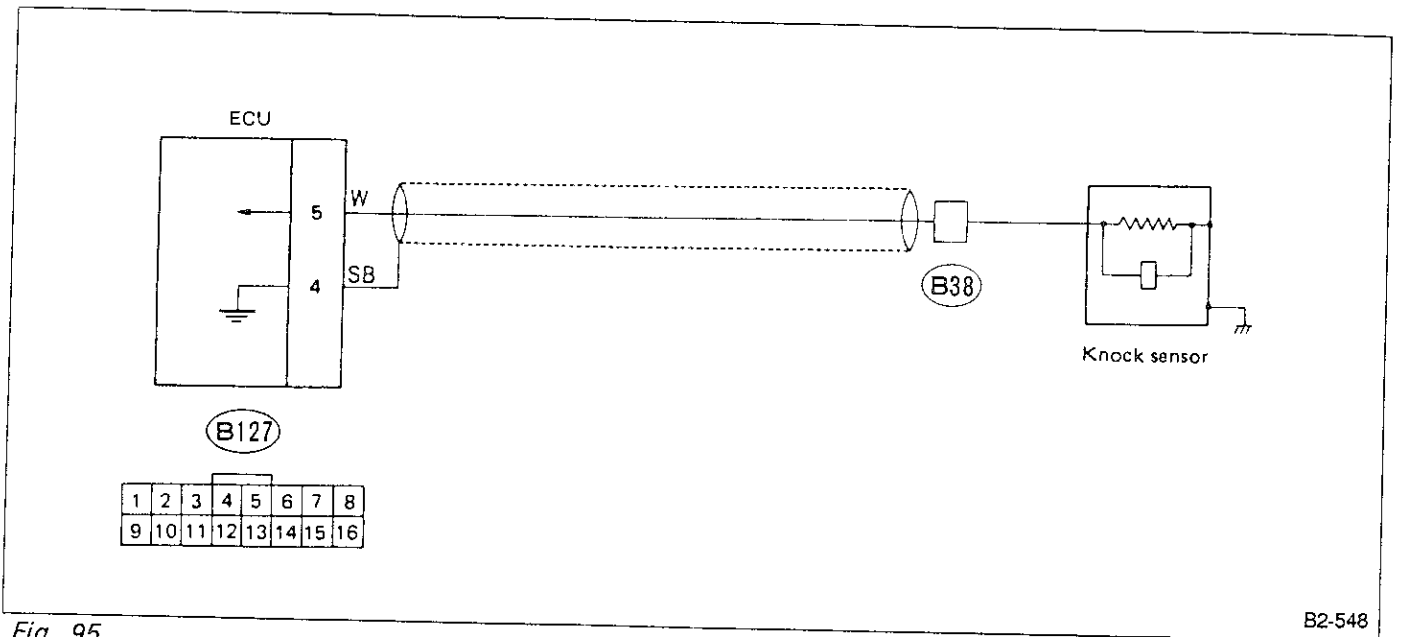
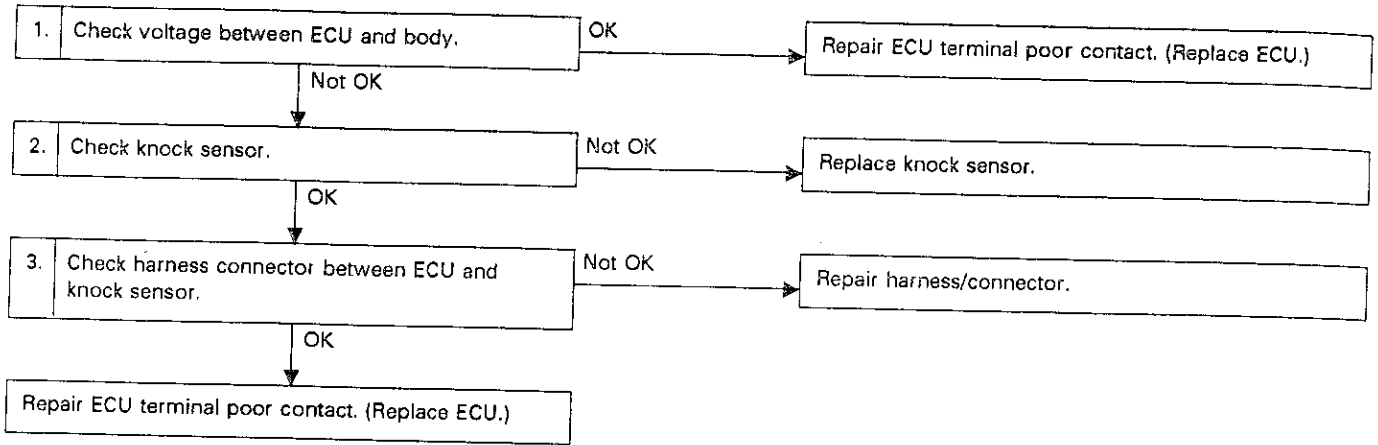


Fig. 95

B2-548

1. CHECK VOLTAGE BETWEEN ECU AND BODY.

- 1) Turn ignition switch to "ON".
- 2) Measure voltage between ECU connector terminal and body.

Connector & Terminal/Specified voltage:

(B127) No. 5 — Body/3 — 4 V

2. CHECK KNOCK SENSOR.

- 1) Disconnect connector from knock sensor.
- 2) Measure resistance between knock sensor terminal and body.

Specified resistance:

Approx. 560 k Ω

3. CHECK HARNESS CONNECTOR BETWEEN ECU AND KNOCK SENSOR.

- 1) Disconnect connectors from ECU and knock sensor.
- 2) Measure resistance between ECU and knock sensor connectors.

Connector & Terminal/Specified resistance:

(B127) No. 5 — (B38) No. 1/0 Ω

- 3) Measure resistance between knock sensor connector and body.

Connector & Terminal/Specified resistance:

(B38) No. 1 — Body/1 M Ω min.

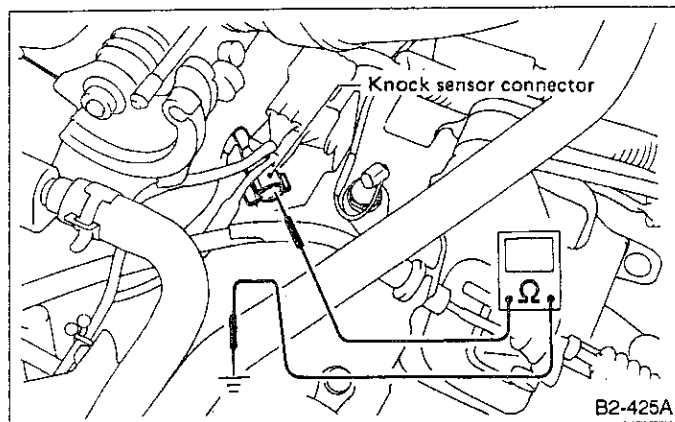
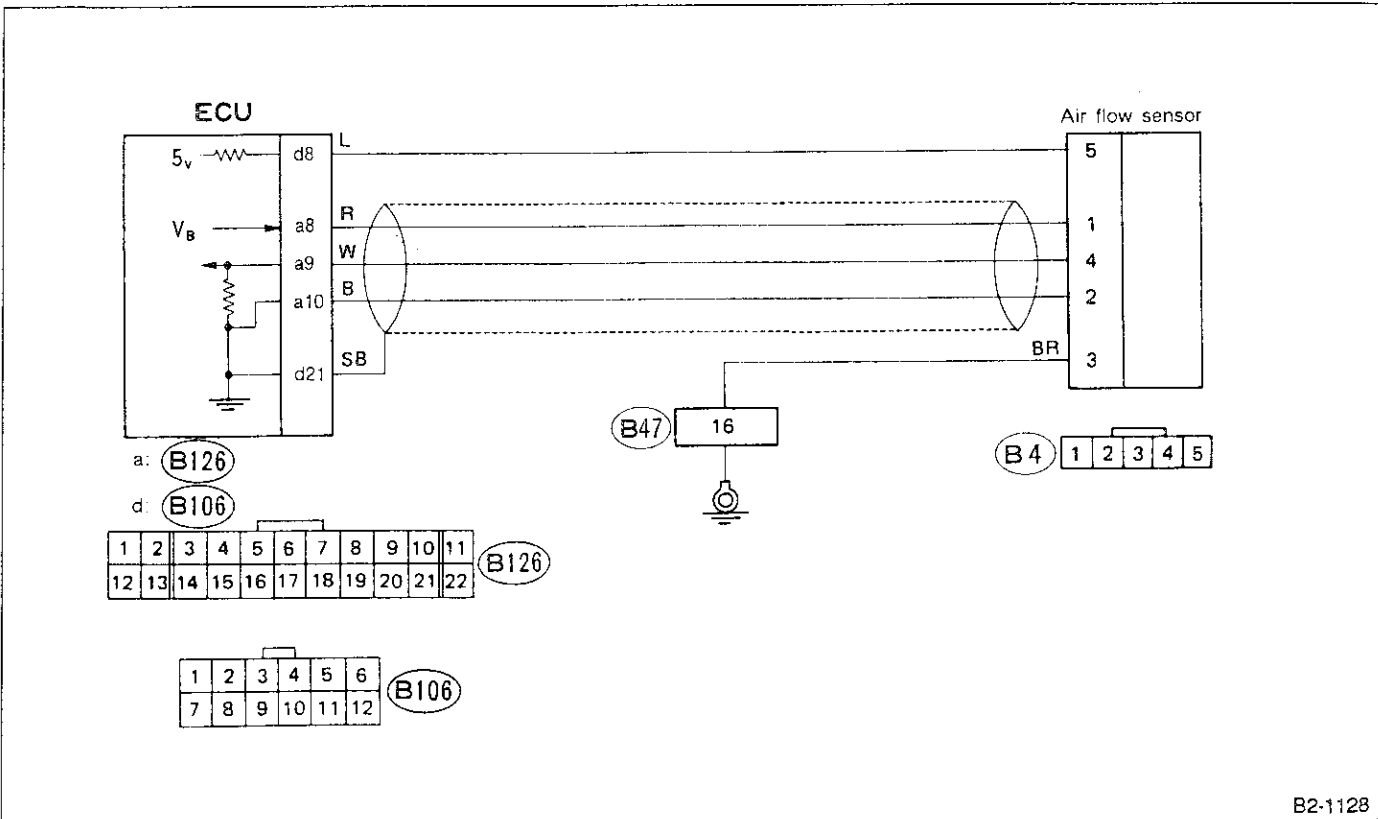
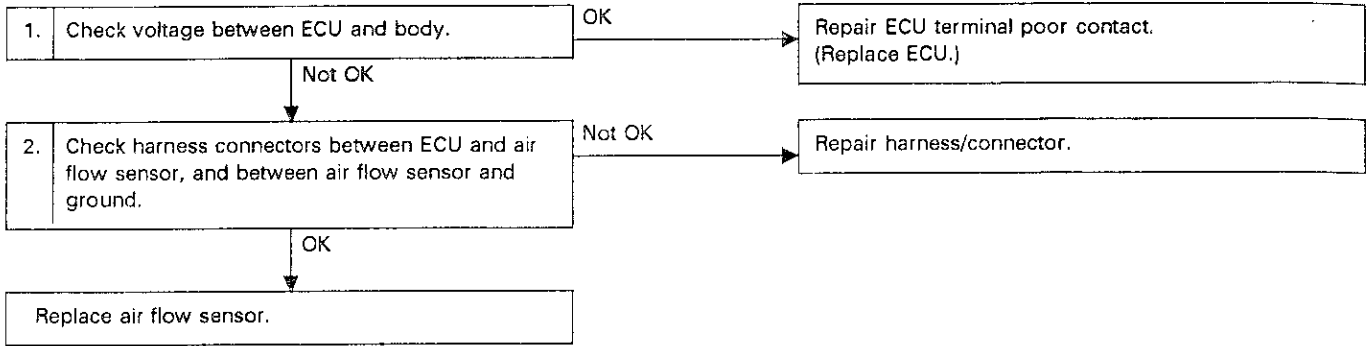


Fig. 96

G: TROUBLE CODE (23) — AIR FLOW SENSOR —

CONTENT OF DIAGNOSIS:
Abnormal voltage input entered from air flow sensor

TROUBLE SYMPTOM:
 • Erroneous idling
 • Engine stall
 • Poor driving performance



B2-1128

Fig. 97

1. CHECK VOLTAGE BETWEEN ECU AND BODY.

- 1) Turn ignition switch to "ON".
- 2) Measure voltage between ECU connector terminal and body.

Connector & Terminal/Specified voltage:

- (B126) No. 8 — Body/
10 - 13 V (Engine OFF)
13 - 14 V (Engine at idle)
- (B126) No. 9 — Body/
0 - 0.3 V (Engine OFF)
0.8 - 1.2 V (Engine at idle)
- (B126) No. 10 — Body/
0 V (Engine OFF)
0 V (Engine at idle)

2. CHECK HARNESS CONNECTOR BETWEEN ECU AND AIR FLOW SENSOR.

- 1) Disconnect ECU and air flow sensor connectors.
- 2) Measure resistance between ECU and air flow sensor connectors.

Connector & Terminal/Specified resistance:

- (B126) No. 8 — (B4) No. 1/0 Ω
(B126) No. 9 — (B4) No. 4/0 Ω
(B126) No. 10 — (B4) No. 2/0 Ω

- 3) Measure resistance between air flow sensor connector and body.

Connector & Terminal/Specified resistance:

- (B4) No. 1 — Body/1 M Ω min.
(B4) No. 4 — Body/1 M Ω min.
(B4) No. 2 — Body/1 M Ω min.
(B4) No. 3 — Body/0 Ω

• SELECT MONITOR FUNCTION MODE

Mode: F08

Condition: Engine at idle

Specified Data: QA F08

0.8 — 1.2 V

H: TROUBLE CODE (24) — BY-PASS AIR CONTROL VALVE —

CONTENT OF DIAGNOSIS:
Air control valve inoperative

TRUBLE SYMPTOM:

- Erroneous idling
- Engine stall
- Engine breathing

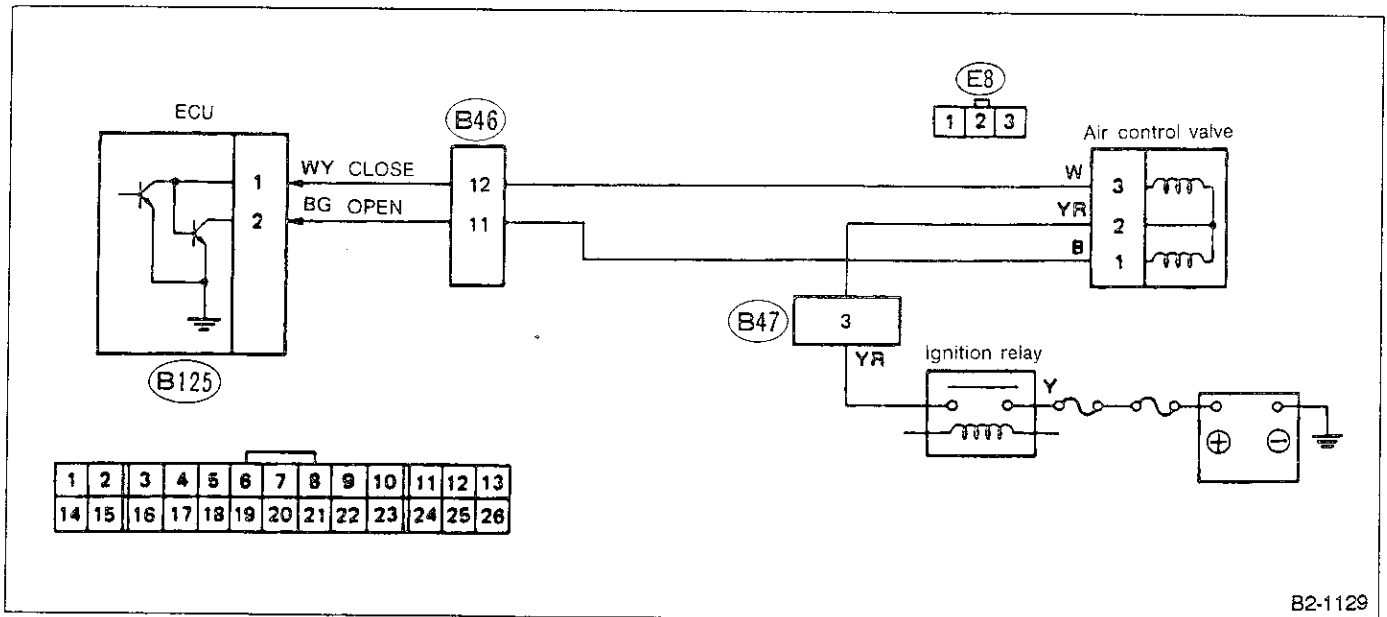
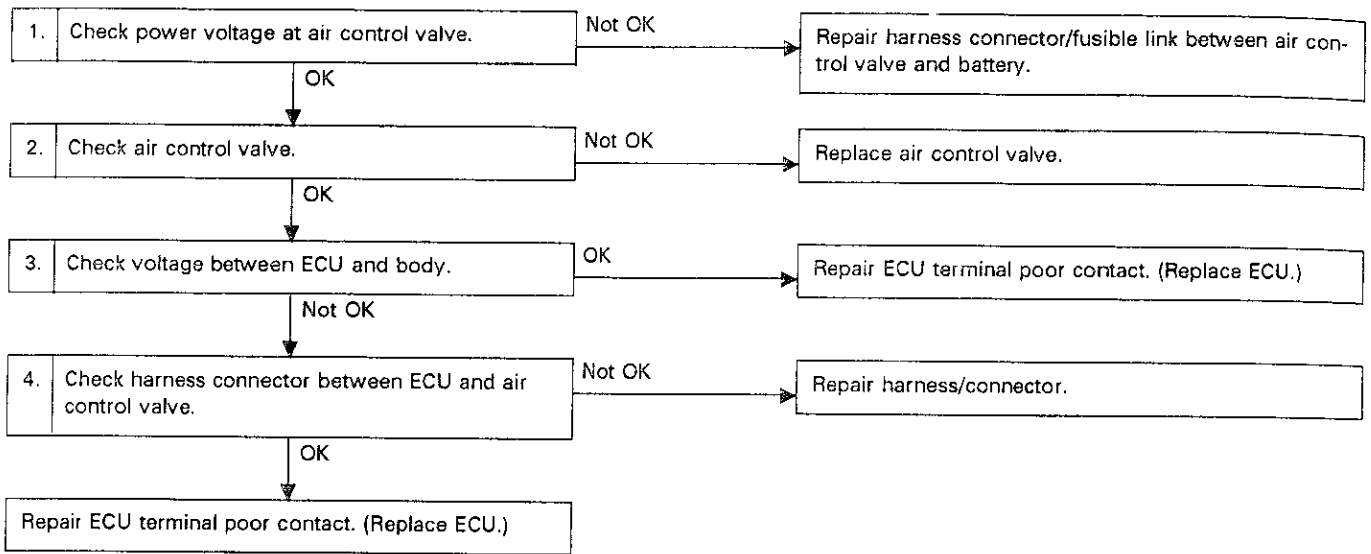


Fig. 98

B2-1129

1. CHECK POWER VOLTAGE AT AIR CONTROL VALVE.

- 1) Turn ignition switch to "ON".
- 2) Measure voltage between air control valve connector terminal and body.

Connector & Terminal/Specified voltage:
(E8) No. 2 — Body/10 V, min.

2. CHECK AIR CONTROL VALVE.

- 1) Disconnect connector from air control valve.
- 2) Measure resistance between air control valve terminals.

Connector & Terminal/Specified resistance:
No. 1 — No. 2/9 Ω
No. 2 — No. 3/9 Ω

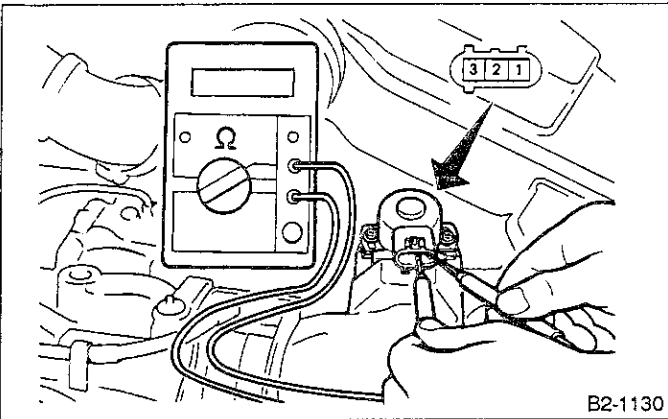


Fig. 99

3. CHECK VOLTAGE BETWEEN ECU AND BODY.

- 1) Turn ignition switch to "ON".
- 2) Measure voltage between ECU connector terminal and body.

Connector & Terminal/Specified voltage:
(B125) No. 2 — Body/8 — 9 V
(B125) No. 1 — Body/6 — 7 V

- 1) Disconnect connectors from ECU and air control valve.
- 2) Measure resistance between ECU connector and control valve connector.

Connector & Terminal/Specified resistance:
(B125) No. 2 — (E8) No. 1/0 Ω
(B125) No. 1 — (E8) No. 3/0 Ω

- 3) Measure resistance between air control valve connector and body.

Connector & Terminal/Specified resistance:
(E8) No. 1 — Body/1 MΩ min.
(E8) No. 3 — Body/1 MΩ min.

• **SELECT MONITOR FUNCTION MODE**

Mode: F12
Condition: Engine at idle
Specified Data: ISC F12
 30 — 45%

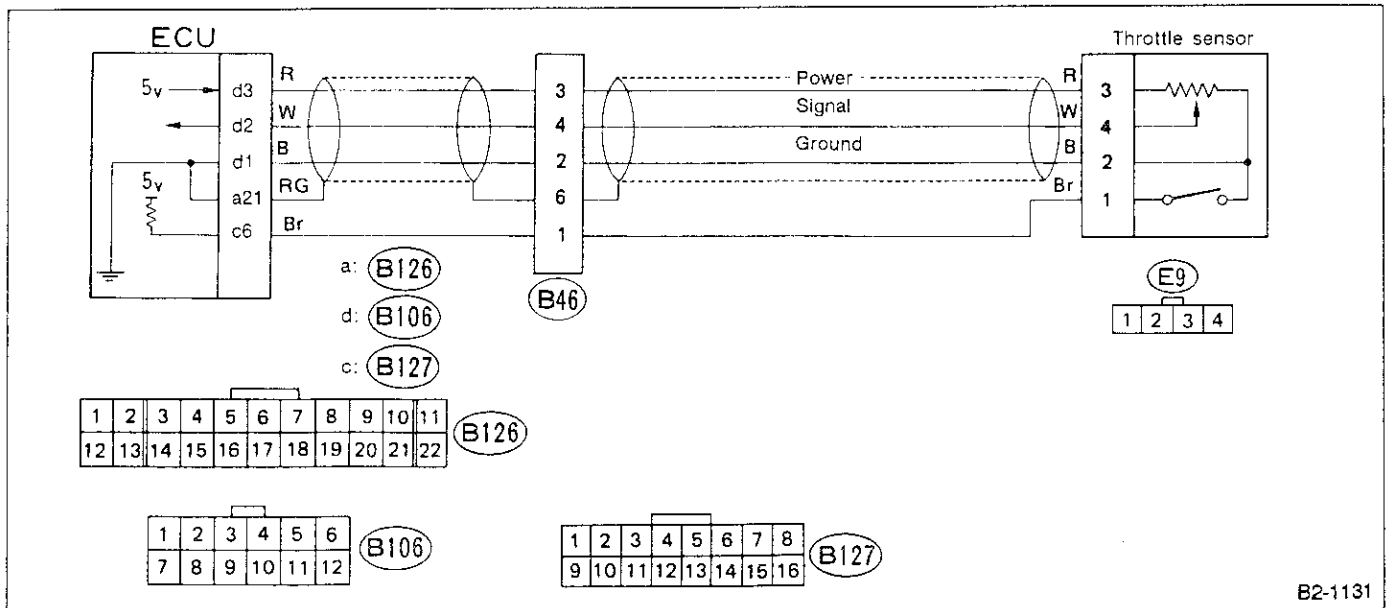
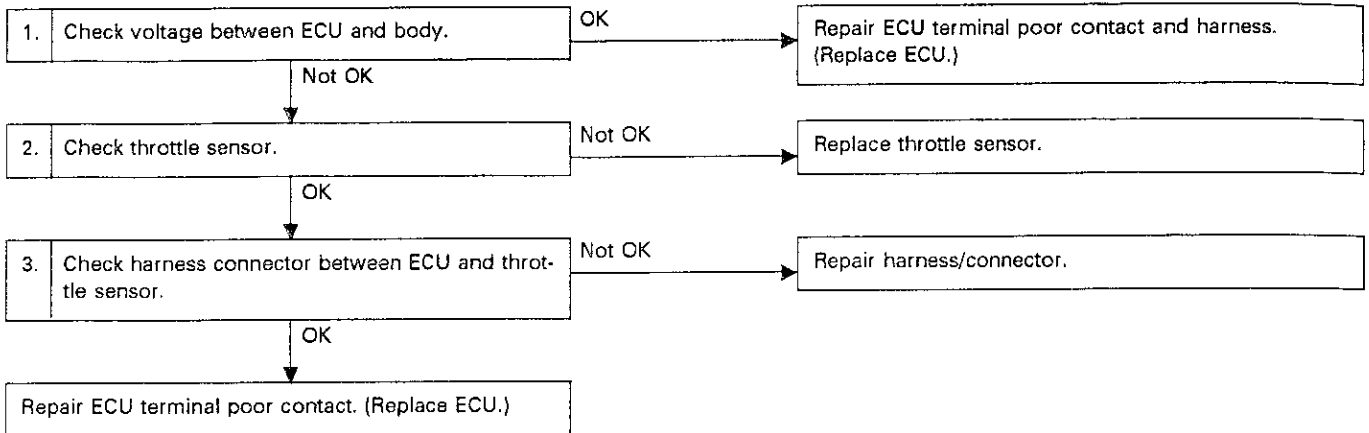
I: TROUBLE CODE (31) — THROTTLE SENSOR —

CONTENT OF DIAGNOSIS:

Abnormal voltage input entered from throttle sensor.

TROUBLE SYMPTOM:

- Erroneous idling
- Engine stall
- Poor driving performance



B2-1131

Fig. 100

1. CHECK VOLTAGE BETWEEN ECU AND BODY.

- 1) Turn ignition switch to "ON".
- 2) Measure voltage between ECU connector terminal and body.

Connector & Terminal/Specified voltage:

- (B106) No. 2 — Body/
4.4 - 4.8 V (Throttle is fully closed.)
0.7 - 1.6 V (Throttle is fully open.)
(Ensure voltage smoothly decreases as throttle valve changes from "closed" to "open".)
- (B106) No. 3 — Body/5 V
- (B106) No. 1 — Body/0 V

2. CHECK THROTTLE SENSOR.

- 1) Disconnect connector from throttle sensor.
- 2) Measure resistance between throttle sensor terminals.

Connector & Terminal/Specified resistance:

- No. 2 — No. 3/12 kΩ

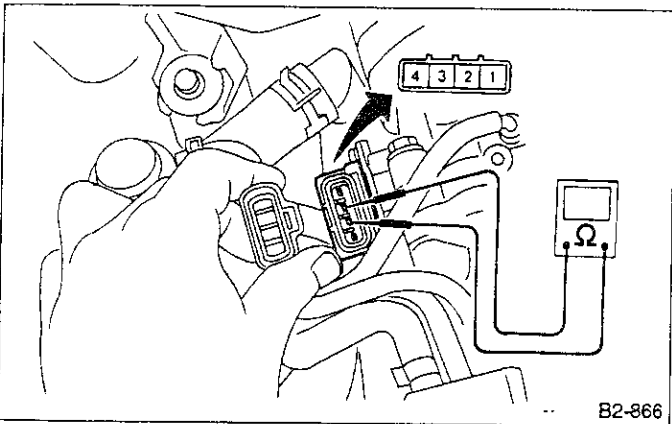


Fig. 101

- 3) Measure resistance between terminals while slowly opening throttle valve from the "closed" position.

Terminal/Specified resistance:

- No. 2 — No. 4/ 10 — 12 kΩ (Throttle is fully closed.)
3 — 5 kΩ (Throttle is fully open.)
- Ensure resistance increases in response to throttle valve opening.

3. CHECK HARNESS CONNECTOR BETWEEN ECU AND THROTTLE SENSOR.

- 1) Disconnect connectors from ECU and throttle sensor.
- 2) Measure resistance between ECU connector and throttle sensor connectors.

Connector & Terminal/Specified resistance:

- (B106) No. 1 — (E9) No. 2 / 0 Ω
- (B106) No. 2 — (E9) No. 4 / 0 Ω
- (B106) No. 3 — (E9) No. 3 / 0 Ω

- 3) Measure resistance between throttle sensor connector and body.

Connector & Terminal/Specified resistance:

- (E9) No. 2 — Body/1 MΩ min.
- (E9) No. 4 — Body/1 MΩ min.
- (E9) No. 3 — Body/1 MΩ min.

• SELECT MONITOR FUNCTION MODE

Mode: F10

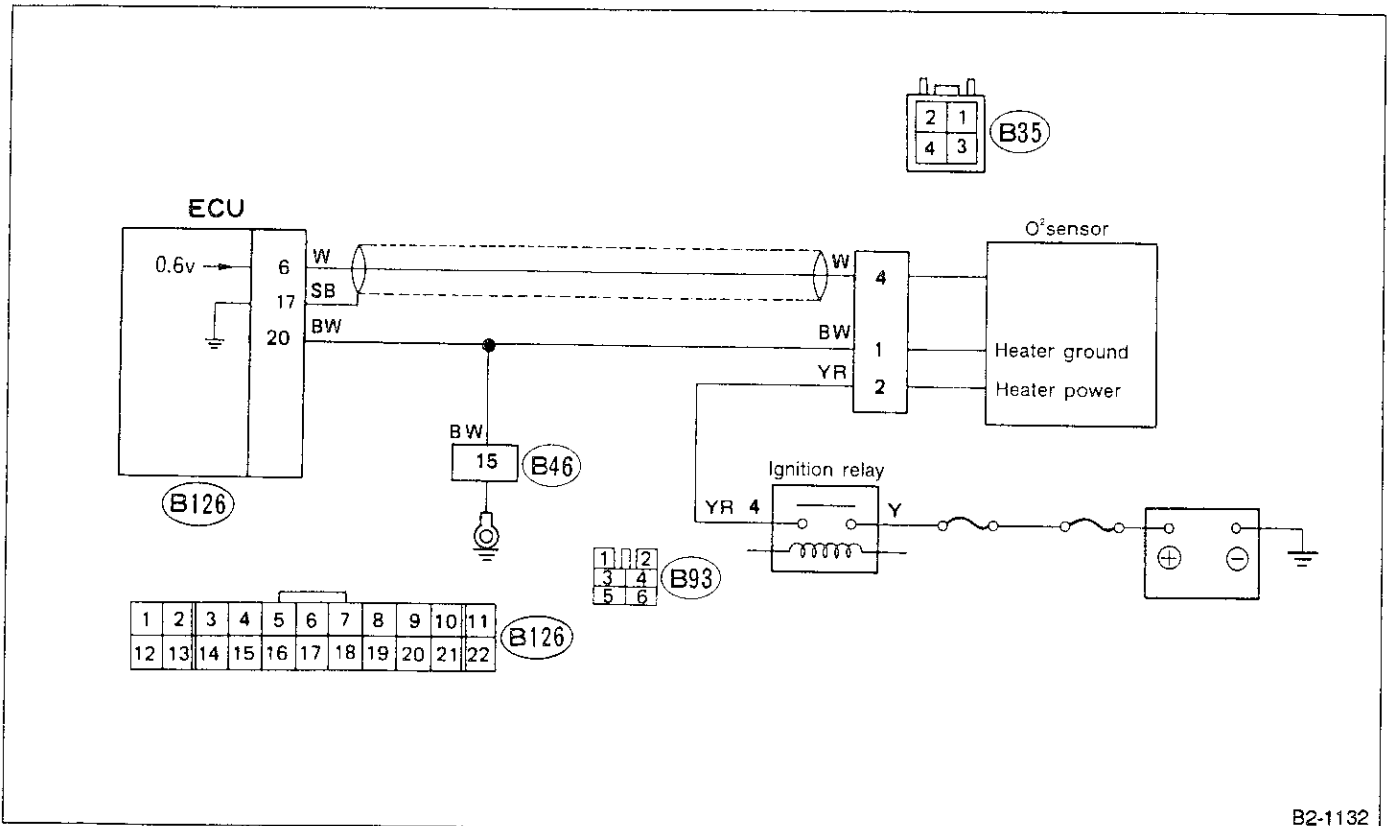
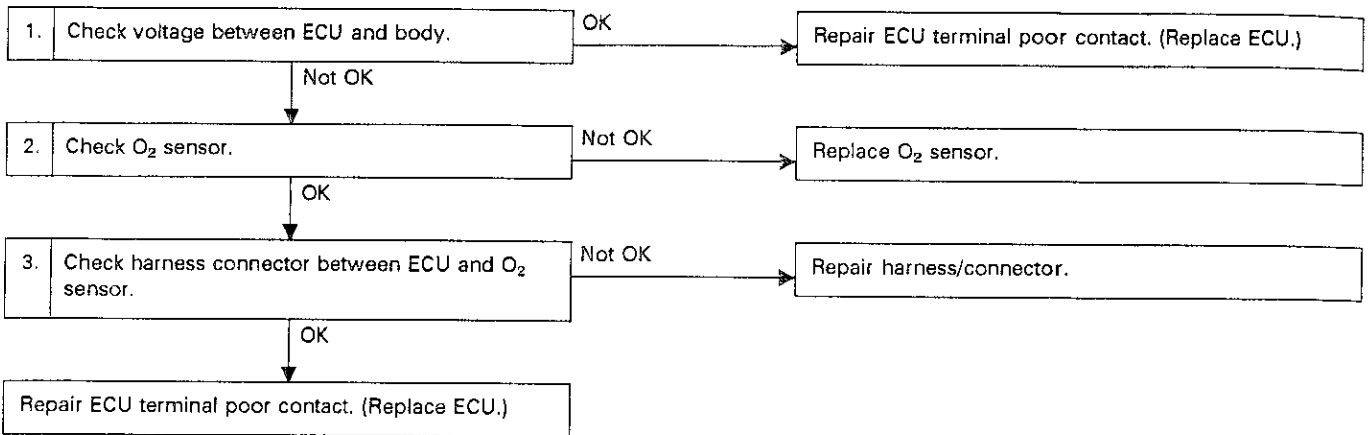
Condition: Ignition switch ON and throttle valve fully closed and open

Specified Data: THV F10
4.7 V (Throttle valve fully closed)
0.9 V (Throttle valve fully open)

J: TROUBLE CODE (32) — O₂ SENSOR —

CONTENT OF DIAGNOSIS:
O₂ sensor inoperative

TRUBLE SYMPTOM:
 • Failure of engine to start
 • Erroneous idling
 • Poor driving performance
 • Engine stall



B2-1132

Fig. 102

1. CHECK VOLTAGE BETWEEN ECU AND BODY.

Measure voltage between ECU connector terminal and body while idling engine.

Connector & Terminal/Specified voltage:
(B126) No. 6 — Body/0.1 — 0.9 V

Problems in heater circuit causes O₂ sensor to deactivate.

2. CHECK O₂ SENSOR.

- 1) Idle engine.
- 2) Disconnect O₂ sensor connector.
- 3) Measure voltage between O₂ sensor terminal and body.

Connector & Terminal/Specified voltage:
No. 4 — Body/0.1 — 0.9 V

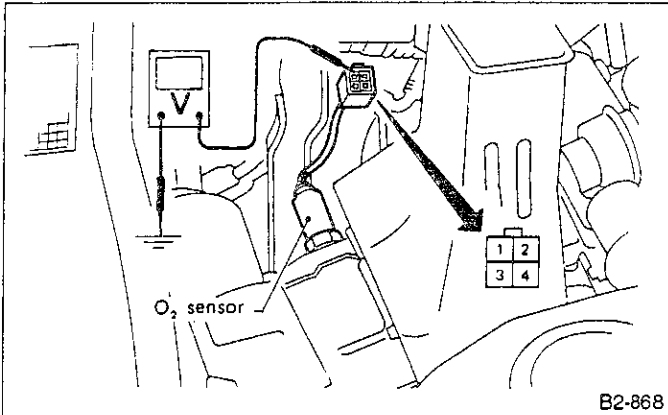


Fig. 103

3. CHECK HARNESS CONNECTOR BETWEEN ECU AND O₂ SENSOR.

- 1) Disconnect connectors from ECU and O₂ sensor.
- 2) Measure resistance between ECU connector and O₂ sensor connector.

Connector & Terminal/Specified resistance:
(B126) No.6 — (B35) No. 4/0 Ω

- 3) Measure resistance between O₂ sensor connector and body.

Connector & Terminal/Specified resistance:
(B35) No. 4 — Body /1 MΩ min.

• **SELECT MONITOR FUNCTION MODE**

Mode: F13, F15, F16

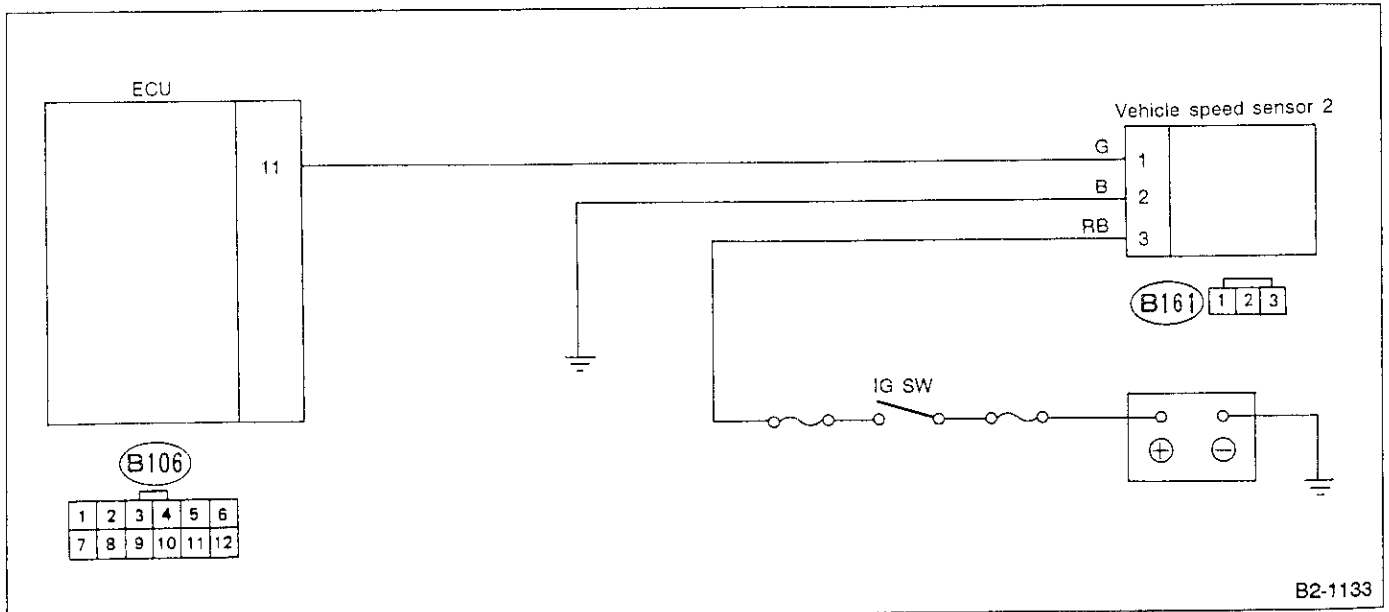
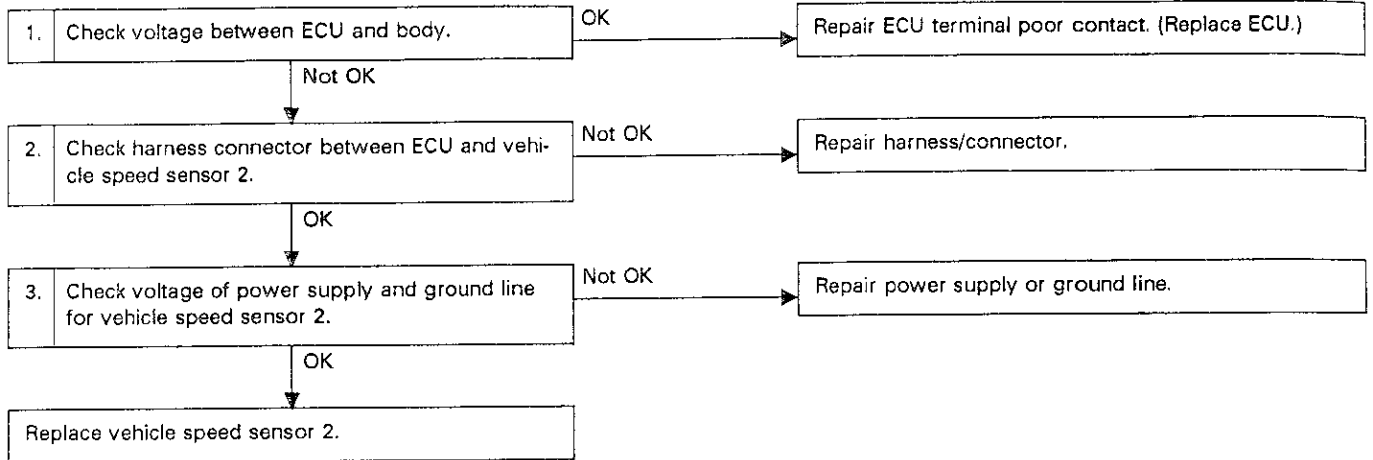
Condition : After driving at more than 7 MPH for at least one minute with engine warmed up.

Specified Data:	O2	F13
	0.1 — 0.9 V	
	O2 max.	F15
	0.7 — 1.0 V	
	O2 min.	F16
	0 — 0.2 V	

K: TROUBLE CODE (33) — SPEED SENSOR 2 —

CONTENT OF DIAGNOSIS:
Abnormal voltage input entered from speed sensor 2

TRouble SYMPTOM:
 • Erroneous idling
 • Engine stall
 • Poor driving performance



B2-1133

Fig. 104

1. CHECK VOLTAGE BETWEEN ECU AND BODY.

- 1) Raise vehicle and support with safety stands.
Ensure all four wheels are off the ground.
- 2) Measure voltage between ECU connector terminal and body while slowly driving wheels.

Connector & Terminal/Specified voltage:
(B106) No. 11 — Body/0 ↔ 5 V

2. CHECK HARNESS CONNECTOR BETWEEN ECU AND VEHICLE SPEED SENSOR.

- 1) Remove connector from ECU and vehicle speed sensor 2.
- 2) Measure resistance between ECU connector and vehicle speed sensor 2 connector.

Connector & Terminal/Specified resistance:
(B106) No. 11 — (B161) No. 1/0 Ω

- 3) Measure resistance between vehicle speed sensor 2 connector and body.

Connector & Terminal/Specified resistance:
(B161) No. 1 — Body/1 MΩ min.

3. CHECK VOLTAGE OF POWER SUPPLY AND GROUND LINE FOR VEHICLE SPEED SENSOR 2.

- 1) Disconnect connector from vehicle speed sensor 2.
- 2) Turn ignition switch to "ON".
- 3) Measure voltage between vehicle speed sensor 2 connector and body.

Connector & Terminal/Specified voltage:
(B161) No. 3 — Body/10 V, min.

Connector & Terminal/Specified resistance:
(B161) No. 2 — Body/0 Ω

• **SELECT MONITOR FUNCTION MODE**

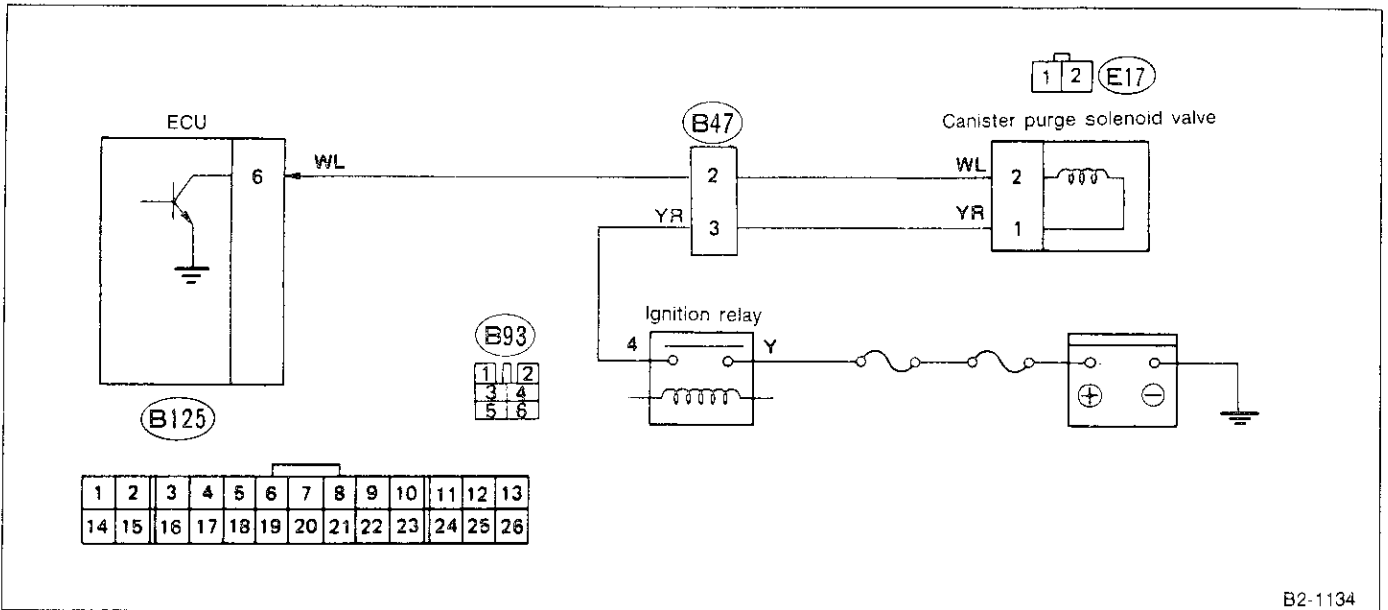
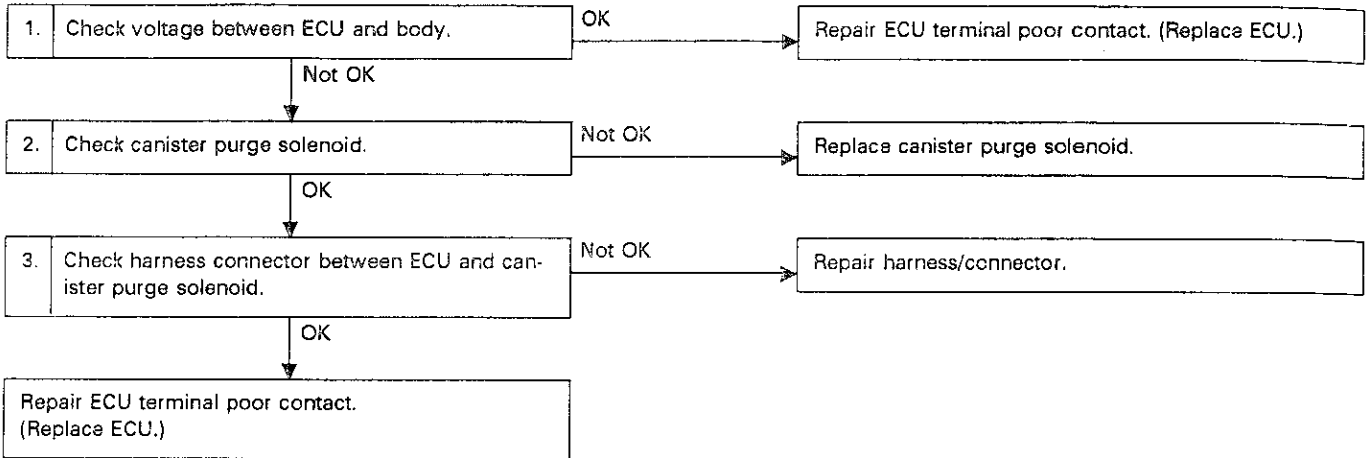
Mode: F03

Condition: While driving vehicle:
Specified data: VSP F02
(Car speed) km/h

L: TROUBLE CODE (35) — CANISTER PURGE SOLENOID VALVE —

CONTENT OF DIAGNOSIS:
Solenoid valve inoperative

TROUBLE SYMPTOM:
• Erroneous idling



B2-1134

Fig. 105

1. CHECK VOLTAGE BETWEEN ECU AND BODY.

- 1) Turn ignition switch to "ON" with engine OFF.
- 2) Measure voltage between ECU connector terminal and body.

Connector & Terminal/Specified voltage:
(B125) No. 6 — Body/10 — 13 V

2. CHECK CANISTER PURGE SOLENOID VALVE.

- 1) Disconnect connector from solenoid valve.
- 2) Measure resistance between solenoid valve terminals.

Specified resistance:
35.5 Ω[at 20°C (68°F)]

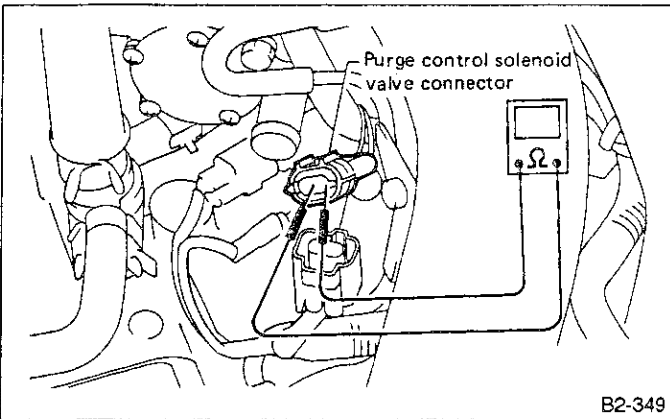


Fig. 106

3. CHECK HARNESS CONNECTOR BETWEEN ECU AND CANISTER PURGE SOLENOID.

- 1) Disconnect connectors from ECU and solenoid valve.
- 2) Measure resistance between ECU connector and solenoid valve connector.

Connector & Terminal/Specified resistance:
(B125) No. 6 — (E17) No. 2/0 Ω

- 3) Measure resistance between solenoid valve connector and body.

Connector & Terminal/Specified resistance:
(E17) No. 2 — Body/1 MΩ min.

- 4) Disconnect ground and positive terminals from battery in that order.
- 5) Measure resistance between solenoid connector and battery's positive terminal.

Connector & Terminal/Specified resistance:
(E17) No. 1 — (+) terminal/0 Ω

• SELECT MONITOR FUNCTION MODE

Mode: FA1
LED No.: 7
ON/OFF Signal: LED OFF (Solenoid OFF)
LED ON (Solenoid ON)

M: TROUBLE CODE (42) — IDLE SWITCH —

CONTENT OF DIAGNOSIS:

Abnormal voltage input entered from idle switch

TROUBLE SYMPTOM:

- Erroneous idling
- Engine stall
- Poor driving performance

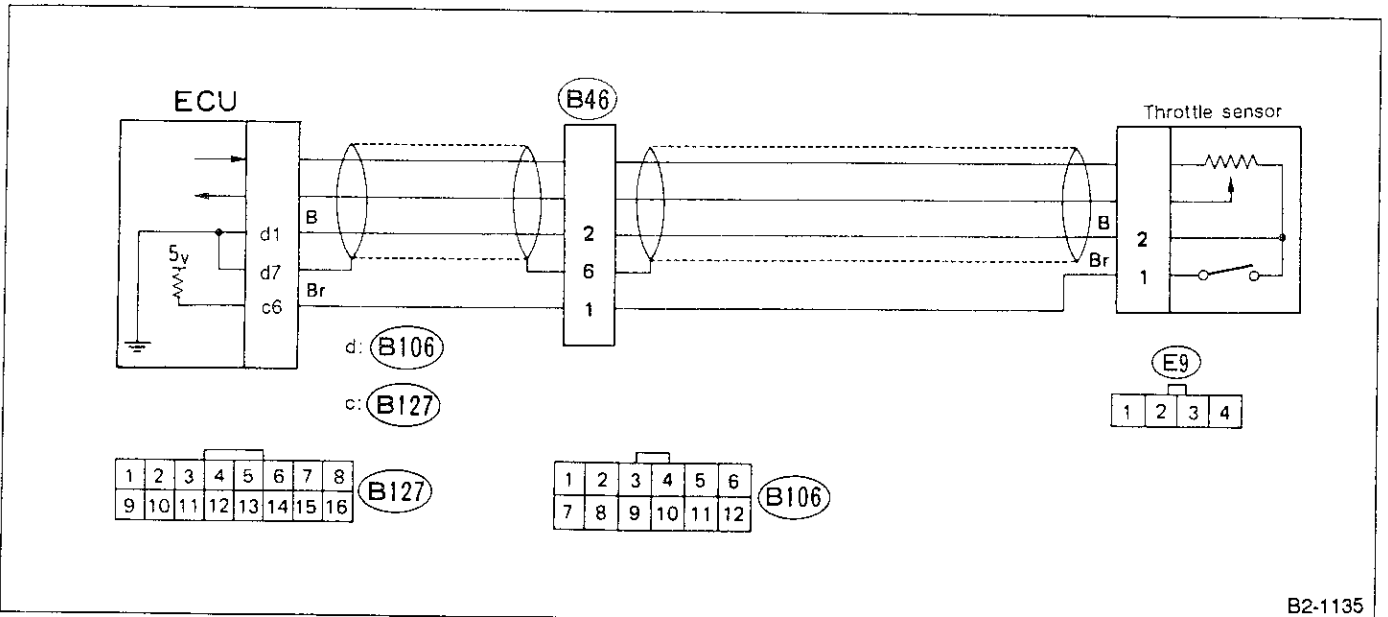
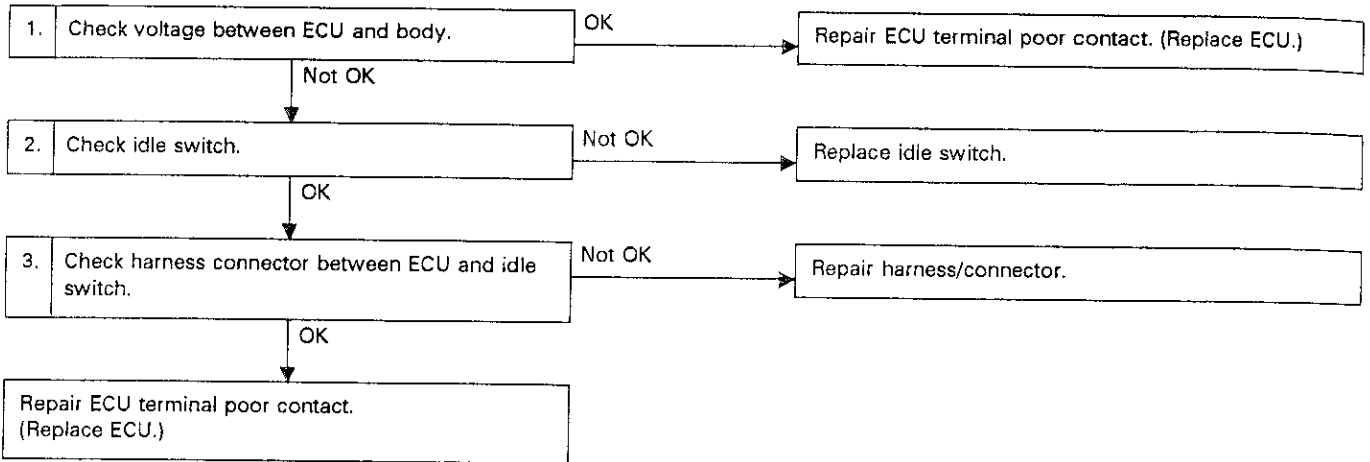


Fig. 107

B2-1135

1. CHECK VOLTAGE BETWEEN ECU AND BODY.

- 1) Turn ignition switch to "ON".
- 2) Measure voltage between ECU connector terminal and body.

Connector & Terminal/Specified voltage:
 (B127) No. 6 — Body/ 0 V (Throttle is fully closed.)
 Approx. 5 V (Throttle is open.)

2. CHECK IDLE SWITCH.

- 1) Disconnect connector from throttle sensor.
- 2) Check continuity between throttle sensor idle switch terminals.

Terminal/Specified resistance:
 No. 1 — No. 2 / 0 Ω (Throttle is fully closed.)
 1 MΩ min. (Throttle is fully open.)

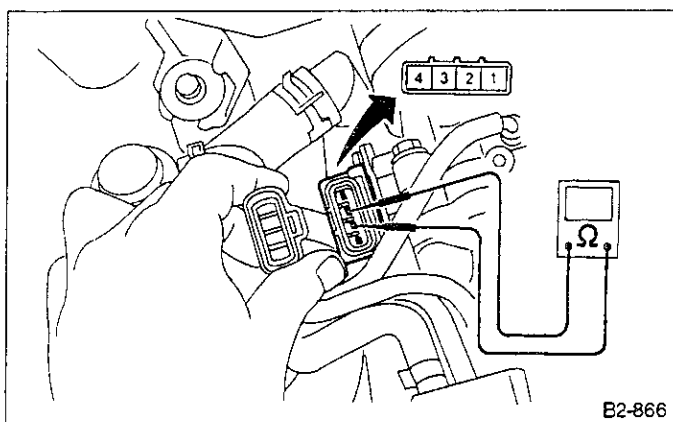


Fig. 108

3) If resistance is outside specifications, adjust idle switch as follows (Before replacement of throttle sensor):

Insert a thickness gauge between the stopper screw of the throttle body and the stopper (Portion G), and check for continuity between terminal No. 1 and No. 2.

- (1) Make sure that No.1 and No. 2 are conducting when the throttle is closed fully.
- (2) Make sure that No. 1 and No. 2 are conducting when the thickness gauge is 0.7 mm (0.028 in).
- (3) Make sure that No. 1 and No. 2 are not conducting when the thickness gauge is 0.9 mm (0.035 in).
- (4) If the above standards are not satisfied, loosen the screws (two) securing the throttle sensor to the throttle body, and turn the throttle sensor main body until the correct adjustment is obtained.

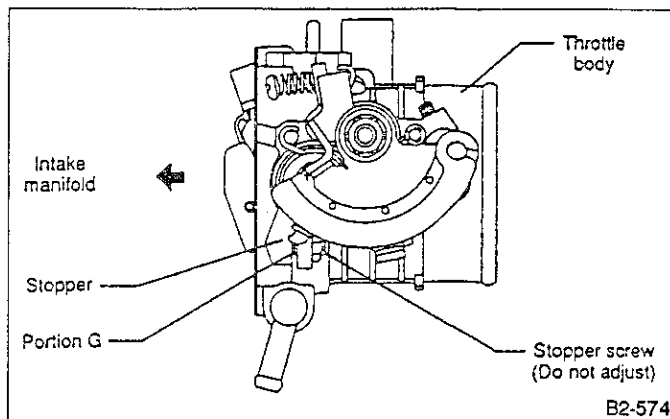


Fig. 109

3. CHECK HARNESS CONNECTOR BETWEEN ECU AND IDLE SWITCH.

- 1) Disconnect connectors from ECU and throttle sensor.
- 2) Measure resistance between ECU connector and throttle sensor connector.

Connector & Terminal/Specified resistance:
 (B127) No. 6 — (E9) No. 1/0 Ω
 (B106) No. 1 — (E9) No. 2/0 Ω

- 3) Measure resistance between throttle sensor connector and body.

Connector & Terminal/Specified resistance:
 (E9) No. 1 — Body/1 MΩ min.
 (E9) No. 2 — Body/1 MΩ min.

• SELECT MONITOR FUNCTION MODE

Mode: FA1

LED No.: 1

Condition: Ignition switch ON

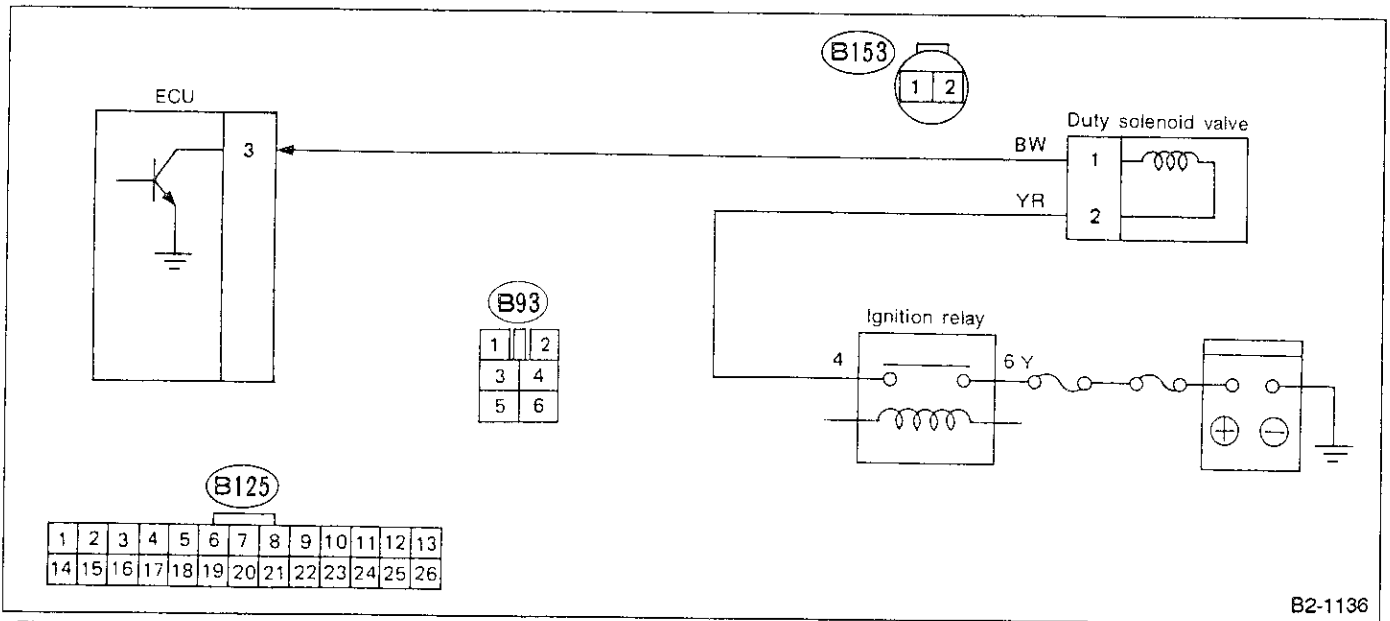
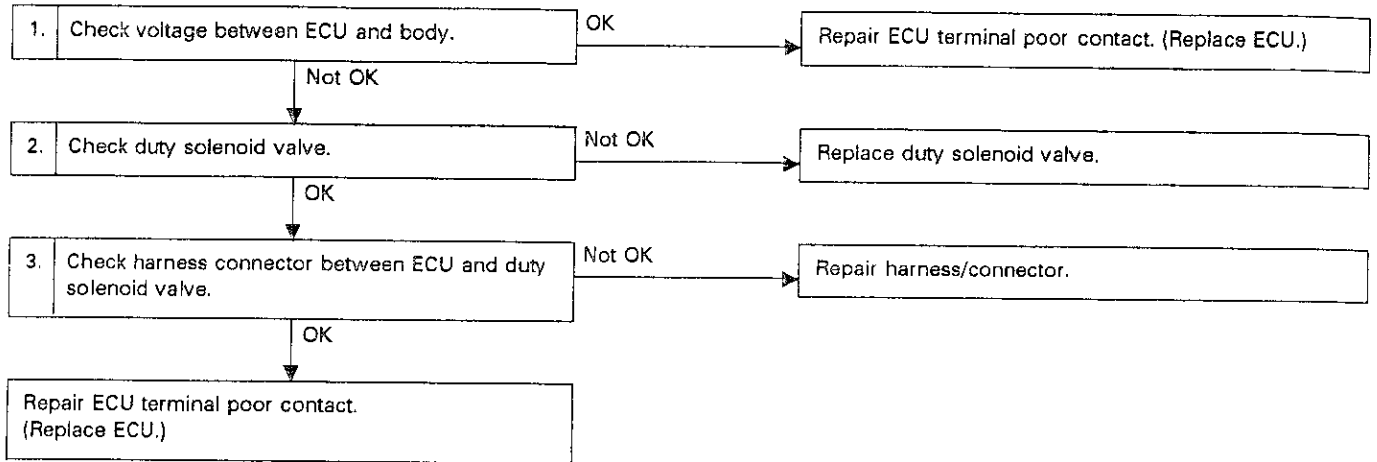
ON/OFF Signal: LED OFF (Idle switch OFF)

LED ON (Idle switch ON)

N: TROUBLE CODE (44) — WASTEGATE CONTROL DUTY SOLENOID VALVE —

CONTENT OF DIAGNOSIS:
Duty solenoid valve inoperative.

TROUBLE SYMPTOM:
Poor driving performance



B2-1136

Fig. 110

1. CHECK VOLTAGE BETWEEN ECU AND BODY.

- 1) Turn ignition switch to "ON".
- 2) Measure voltage between ECU connector terminal and body.

Connector & Terminal/Specified voltage:
 (B125) No. 3 — Body/10 V, min.

2. CHECK DUTY SOLENOID VALVE.

- 1) Disconnect connector from duty solenoid valve.
- 2) Measure resistance between duty solenoid valve terminals.

Terminal/Specified resistance:
 No. 1 — No. 2/20 Ω

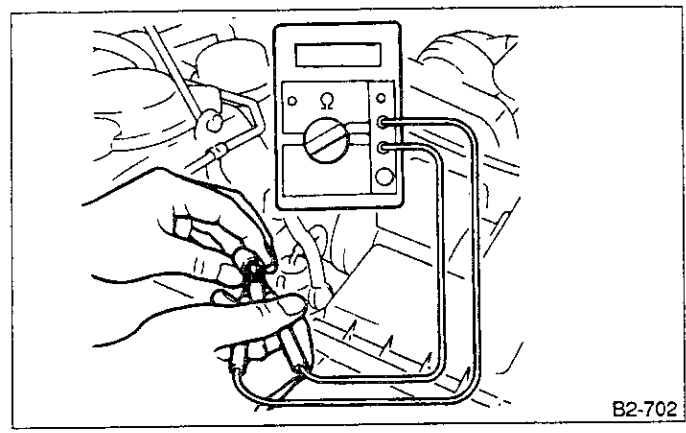


Fig. 111

3. CHECK HARNESS CONNECTOR BETWEEN ECU AND DUTY SOLENOID VALVE.

- 1) Disconnect connector from ECU and duty solenoid valve.
- 2) Check continuity between ECU connector and duty solenoid valve connector.

Connector & Terminal/Specified resistance:
 (B125) No. 3 — (B153) No. 1/0 Ω

- 3) Measure resistance between ECU connector and body.

Connector & Terminal/Specified resistance:
 (B125) No. 3 — Body/1 MΩ min.

- 4) Measure resistance between duty solenoid valve connector and body.

Connector & Terminal/Specified resistance:
 (B153) No. 1 — Body/1 MΩ min.

- 5) Disconnect connector from duty solenoid valve and ignition relay.
- 6) Measure resistance between duty solenoid valve connector and ignition relay connector.

Connector & Terminal/Specified resistance:
 (B153) No. 2 — (B93) No. 4/0 Ω

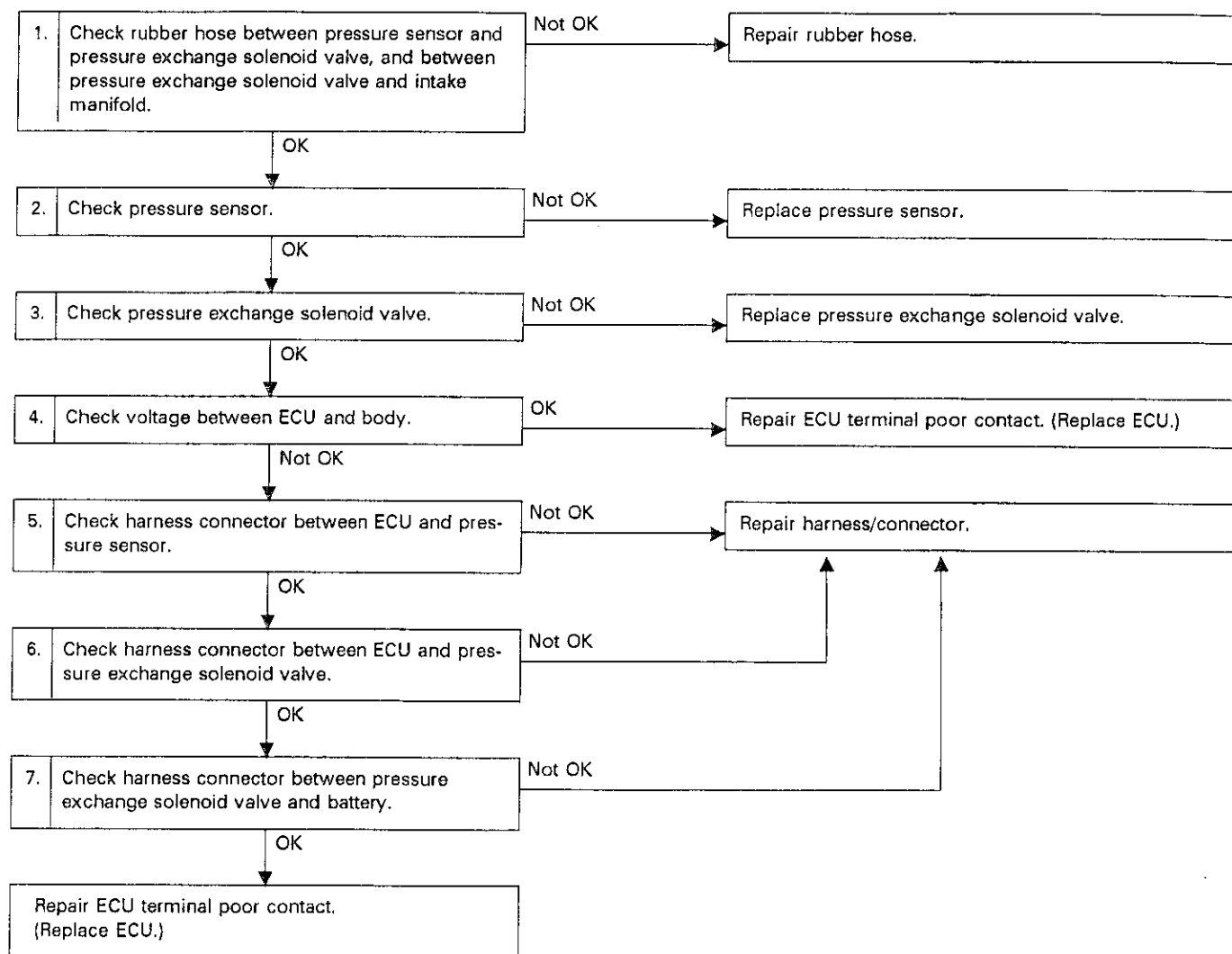
• SELECT MONITOR FUNCTION MODE

Mode: F22
Condition: While driving engine
Specified data: WGC F22
 10 — 70%

O: TROUBLE CODE (45) — PRESSURE SENSOR, PRESSURE EXCHANGE SOLENOID VALVE —

CONTENT OF DIAGNOSIS:
 Abnormal voltage input entered from pressure sensor
 Solenoid valve inoperative

TROUBLE SYMPTOM:
 Poor driving performance



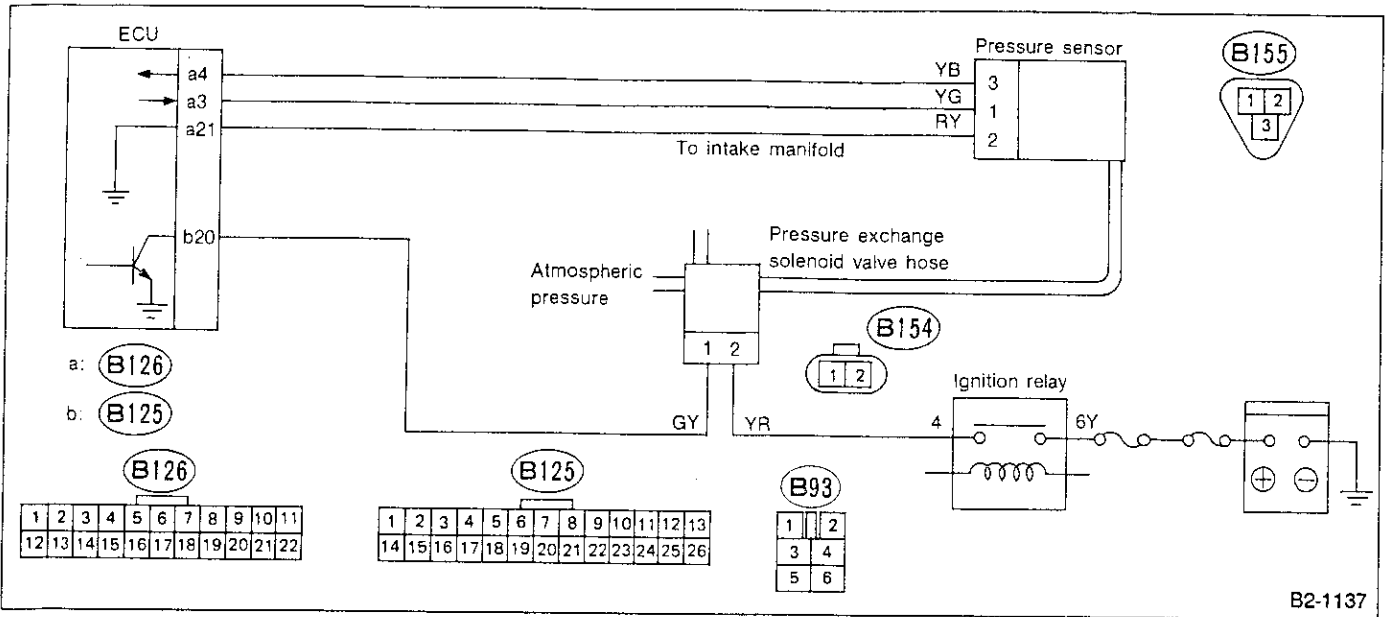


Fig. 112

B2-1137

1. CHECK RUBBER HOSE BETWEEN PRESSURE SENSOR AND PRESSURE EXCHANGE SOLENOID VALVE, AND BETWEEN PRESSURE EXCHANGE SOLENOID VALVE AND INTAKE MANIFOLD.

- 1) Visually check the connection between pressure sensor and rubber hose, between pressure exchange solenoid valve and rubber hose, and between intake manifold and rubber hose.
- 2) Check rubber hose for cracks and damage.

2. CHECK PRESSURE SENSOR.

- 1) Disconnect connector from pressure sensor.
- 2) Apply 5-volt voltage across terminals No. 1 and No. 2, then connect terminal No. 1 to positive side and terminal No. 2 to negative side.
- 3) Install vacuum pump to hose fitting on pressure sensor.
- 4) Measure voltage across terminals when pressure is applied to pressure sensor.

Connector & Terminal/Specified voltage:

No. 2 — No. 3/3.1 V at 26.7 kPa
(200 mmHg, 7.87 inHg)
2.6 V at 0 kPa
(0 mmHg, 0 inHg)
2.1 V at -26.7 kPa
(-200 mmHg, -7.87 inHg)

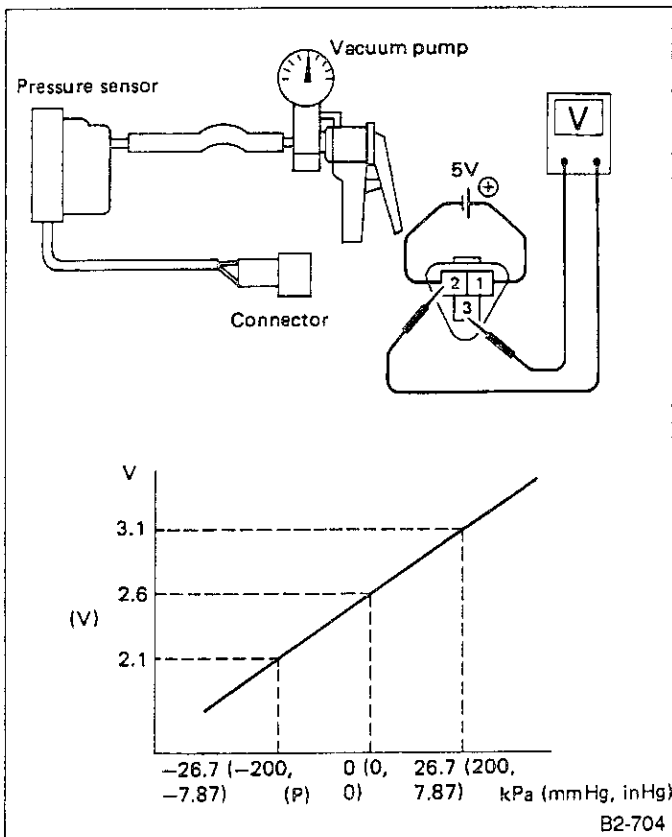


Fig. 113

3. CHECK PRESSURE EXCHANGE SOLENOID VALVE.

- 1) Disconnect connector from pressure exchange solenoid valve.
- 2) Measure resistance across terminals.

Connector & Terminal/Specified resistance:

No. 1 — No. 2/37 \leftrightarrow 48 Ω

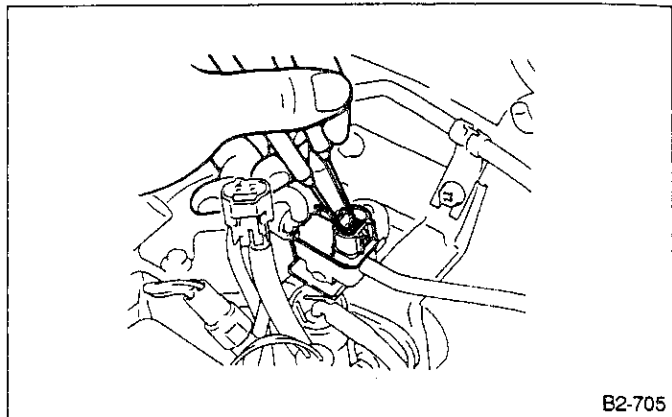


Fig. 114

4. CHECK VOLTAGE BETWEEN ECU AND BODY.

- 1) Connect connector and rubber hose to pressure sensor.
- 2) Connect connectors to pressure exchange solenoid valve.
- 3) Turn ignition switch to "ON".
- 4) Measure voltage between ECU connector terminal and body.

Connector & Terminal/Specified voltage:

(B126) No. 3 — Body/5 V
(B126) No. 4 — Body/2.4 — 2.7 V
(B126) No. 21 — Body/0 V
(B125) No. 20 — Body/0 V or 10 — 13 V

5. CHECK HARNESS CONNECTOR BETWEEN ECU AND PRESSURE SENSOR.

- 1) Disconnect connectors from ECU and pressure sensor.
- 2) Measure resistance between ECU connector and pressure sensor connector.

Connector & Terminal/Specified resistance:

(B126) No. 3 — (B155) No. 1/0 Ω
 (B126) No. 4 — (B155) No. 3/0 Ω
 (B126) No. 21 — (B155) No. 2/0 Ω

- 3) Measure resistance between ECU connector terminal and body.

Connector & Terminal/Specified resistance:

(B126) No. 3 — Body/1 M Ω min.
 (B126) No. 4 — Body/1 M Ω min.
 (B126) No. 21 — Body/1 M Ω min.

6. CHECK HARNESS CONNECTOR BETWEEN ECU AND PRESSURE EXCHANGE SOLENOID VALVE.

- 1) Disconnect connectors from ECU and pressure exchange solenoid valve.
- 2) Measure resistance between ECU connector and pressure exchange solenoid valve connector.

Connector & Terminal/Specified resistance:

(B125) No. 20 — (B154) No. 1/0 Ω

- 3) Measure resistance between ECU connector terminal and body.

Connector & Terminal/Specified resistance:

(B125) No. 20 — Body/1 M Ω min.

7. CHECK HARNESS CONNECTOR BETWEEN PRESSURE EXCHANGE SOLENOID VALVE AND BATTERY.

- 1) Disconnect connectors from pressure exchange solenoid valve and ignition relay.
- 2) Measure resistance between pressure exchange solenoid valve connector and ignition relay connector.

Connector & Terminal/Specified resistance:

(B93) No. 4 — (B154) No. 2/0 Ω

• SELECT MONITOR FUNCTION MODE**Mode: F23**

Condition: Engine at idle

Specified data: BARO.P F23
 700 — 800 mmHg

Mode: F24

Condition: After warming up engine, engine at idle.

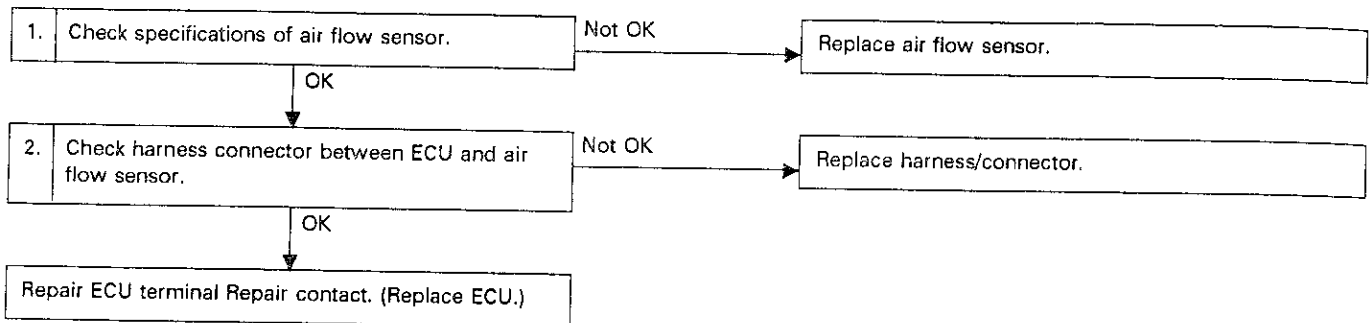
Specified data: MANI.P F24
 - 400 to - 500 mmHg

P: TROUBLE CODE (49) — AIR FLOW SENSOR —

CONTENT OF DIAGNOSIS:
Use of improper air flow sensor

TRouble SYMPTOM:
● Erroneous idling
● Failure of engine to start

When trouble code 49 appears on display, check the specifications of air flow sensor and ECU. Replace air flow sensor (or ECU) with one of a proper type.

**1. CHECK SPECIFICATIONS OF AIR FLOW SENSOR.**

- 1) Disconnect connector from air flow sensor.
- 2) Measure resistance between air flow sensor terminals.

Terminal/Specified resistance:
No. 5 — No. 3/1 M Ω min.

2. CHECK HARNESS CONNECTOR.

- 1) Disconnect ECU and air flow sensor connectors.
- 2) Measure resistance between ECU, air flow sensor connectors and body.

Connector & terminal/Specified resistance
(B4) No. 5 — (B106) No.8/0 Ω
(B4) No. 5 — Body/1 M Ω min.
(B4) No. 3 — Body/0 Ω

Q: TROUBLE CODE (51) — NEUTRAL SWITCH —

CONTENT OF DIAGNOSIS:

Abnormal signal entered from neutral switch

TROUBLE SYMPTOM:

Erroneous idling

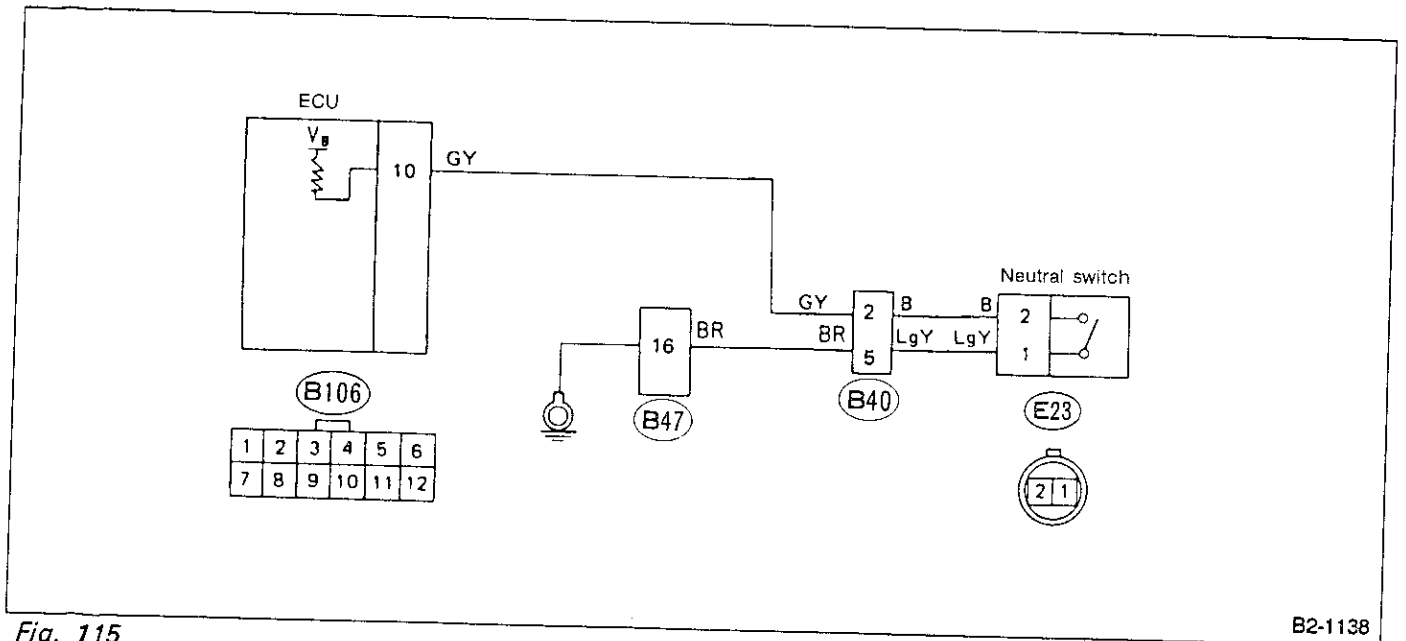
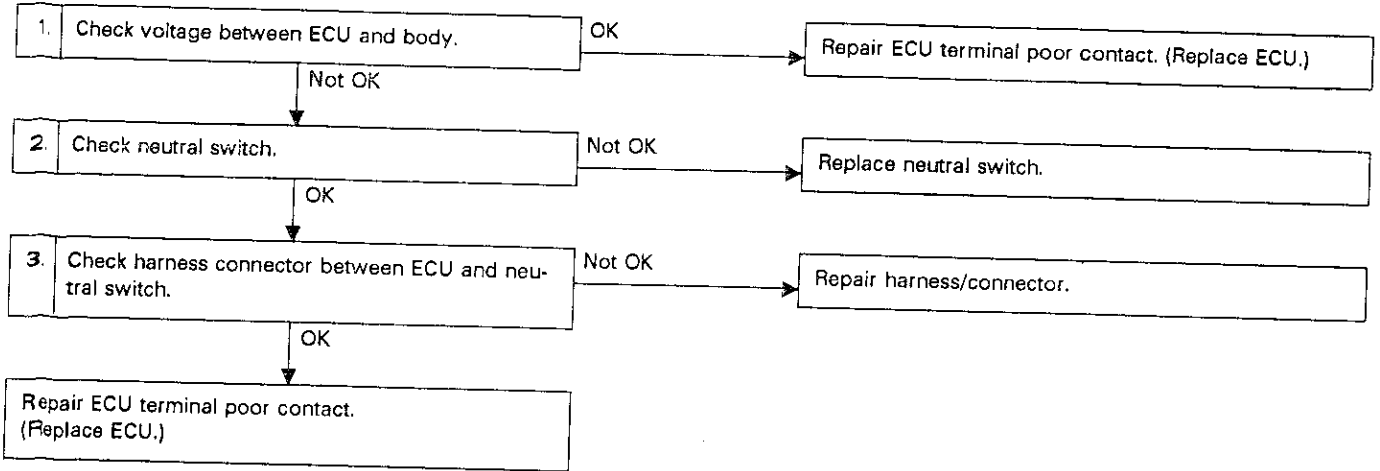


Fig. 115

B2-1138

1. CHECK VOLTAGE BETWEEN ECU AND BODY.

- 1) Turn ignition switch to "ON".
- 2) Measure voltage between ECU connector terminal and body.

Connector & Terminal/Specified voltage:
 (B106) No. 10 — Body/Approx. 7 V, min. (Neutral position)
 0 V (Other than neutral position)

2. CHECK NEUTRAL SWITCH.

- 1) Disconnect neutral switch connectors.
- 2) Measure resistance between neutral switch terminals while shifting shift lever from Neutral to any other position.

Connector & Terminal/Specified resistance:
 (E23) No. 1 — No. 2/ 1 M Ω min. (Neutral position)
 0 Ω (Other than neutral position)

3. CHECK HARNESS CONNECTOR BETWEEN ECU AND NEUTRAL SWITCH.

- 1) Disconnect connectors from ECU and neutral switch.
- 2) Measure resistance between ECU connector and neutral switch connector.

Connector & Terminal/Specified resistance:
 (B106) No. 10 — (E23) No. 2/0 Ω

- 3) Measure resistance between neutral switch connector and body.

Connector & Terminal/Specified resistance:
 (E23) No. 2 — Body/1 M Ω min.
 (E23) No. 1 — Body/0 Ω

● **SELECT MONITOR FUNCTION MODE**

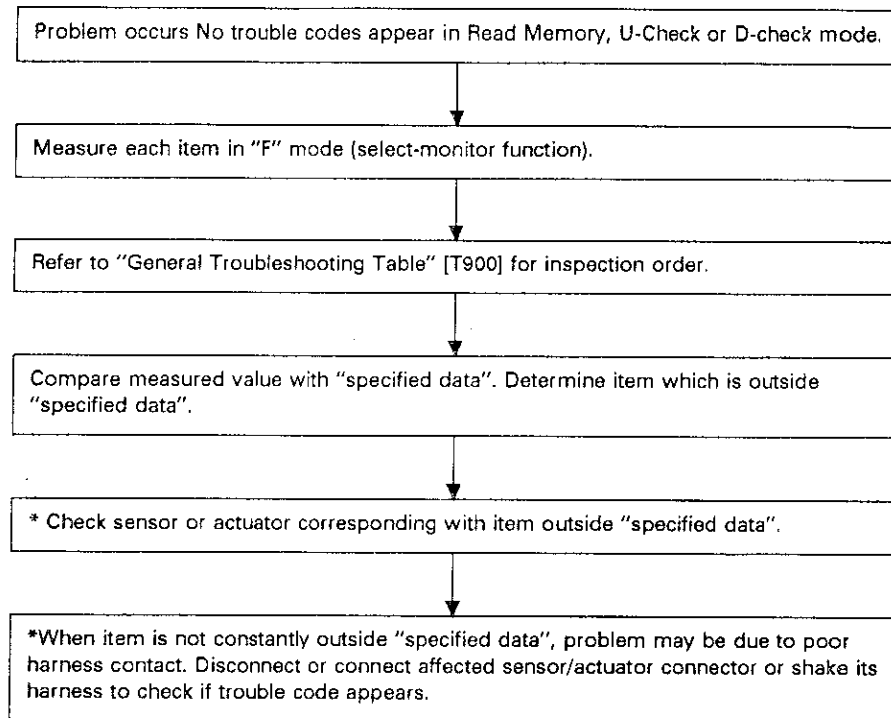
Mode: FA0 LED
No.: 7
Condition: Ignition switch ON
ON/OFF Signal: LED OFF (Other than neutral position)
 LED ON (Neutral position)

8. Troubleshooting Chart with Select Monitor

A: BASIC TROUBLESHOOTING CHART

If no trouble codes appear in the Read Memory, U-Check or D-check mode (although problems have occurred or are occurring), measure performance characteristics of sensors, actuators, etc., in the "F" mode (select-monitor function), and compare with the "basic data" to determine the cause of problems.

Applicable cartridge of select monitor: No. 498348800



B: MODE F01 — Battery voltage (VB) —

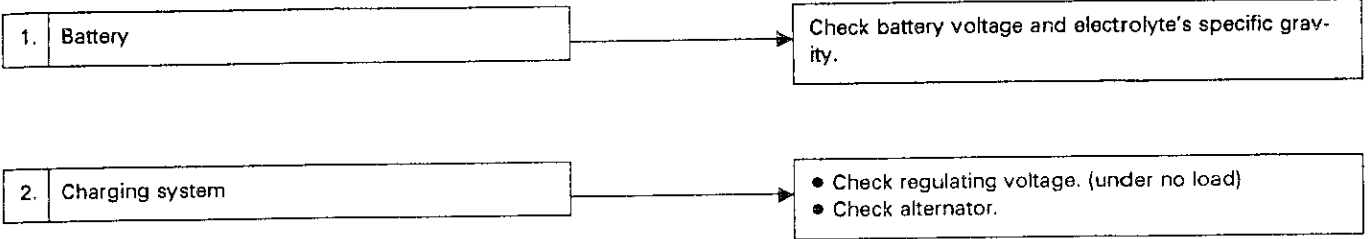
CONDITION:

- (1) Ignition switch "ON"
- (2) Idling after warm-up

SPECIFIED DATA:

- 10 — 12 V (Ignition switch ON, engine OFF)
- 12 — 14 V (Engine at idle)

- Probable cause (item outside "specified data")



C: MODE F03 — Vehicle speed signal (VSP) —

CONDITION:

Raise vehicle until all wheels are off ground, and support with safety stands. Operate vehicle at constant speed.

SPECIFICATION DATA:

Compare speedometer with monitor indications. Probable cause (if indications are different)

- Probable cause (item outside "specified data")



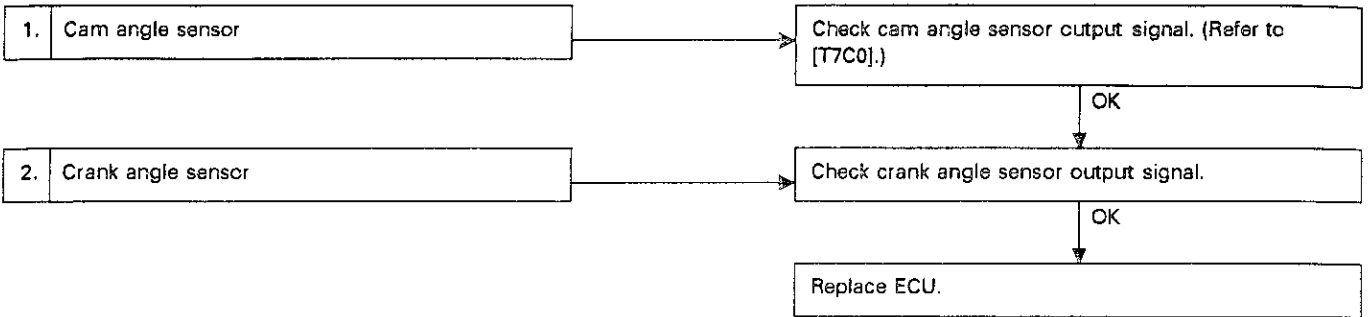
F02 = Vehicle speed signal: Vehicle speed is indicated in kilometer per hour (mph).

D: MODE F04 — Engine speed (EREV) —

CONDITION:
Operate engine at constant speed.

SPECIFIED DATA:
Compare engine speeds indicated on engine tester monitor.

• Probable cause (if outside specified data)

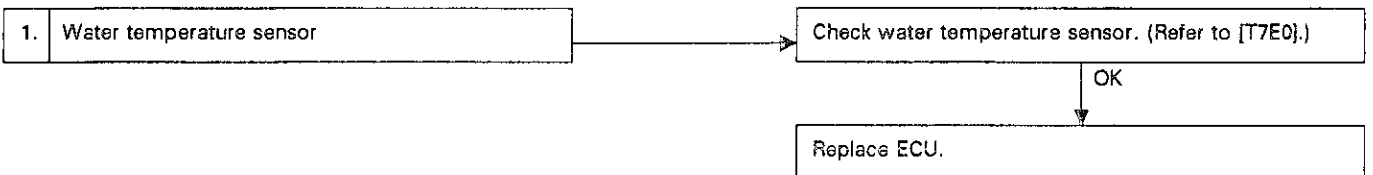


E: MODE F06 — Water temperature sensor signal (TW) —

CONDITION:
Idling after warm-up

SPECIFIED DATA:
80 — 95 deg C

• Probable cause (if outside specified data)



F05 = Water temperature signal (TW): To be indicated in "deg F".

F: MODE F07 — Ignition timing —

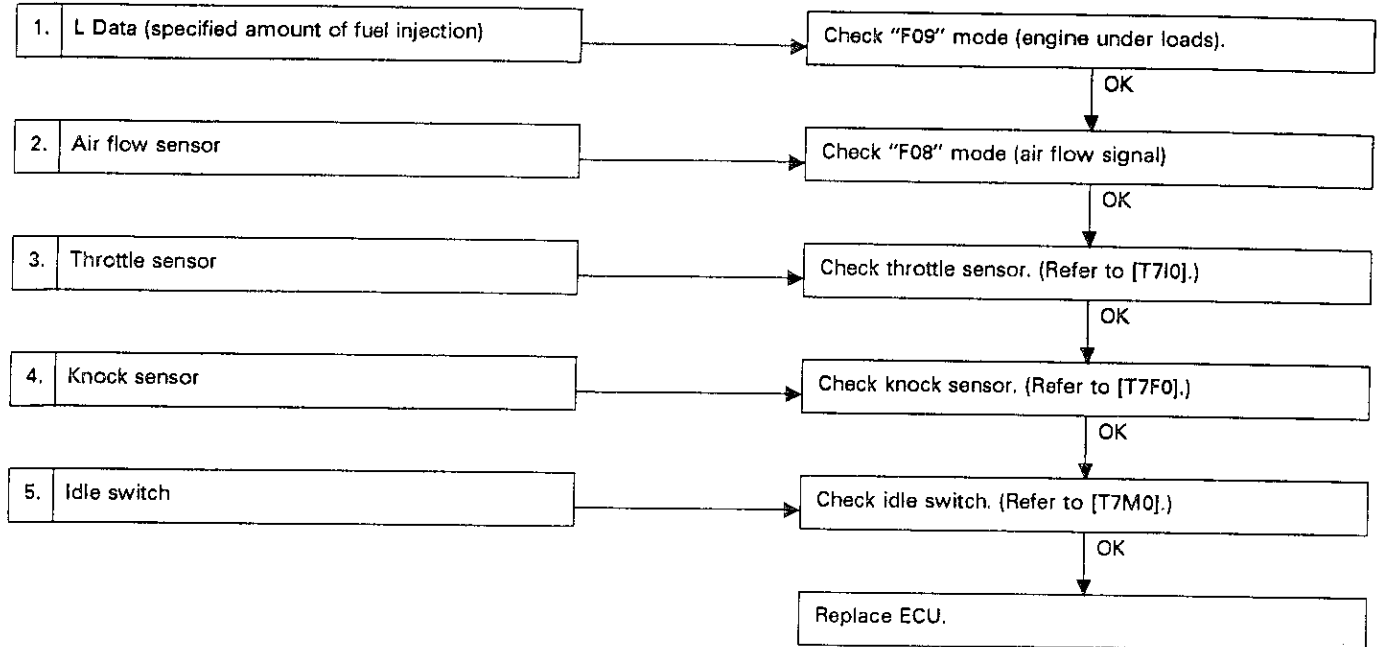
CONDITION:

- (1) While idling after warm-up
- (2) Gear in neutral position

SPECIFIED DATA:

8 deg — 28 deg

• Probable cause (if items outside specified data)

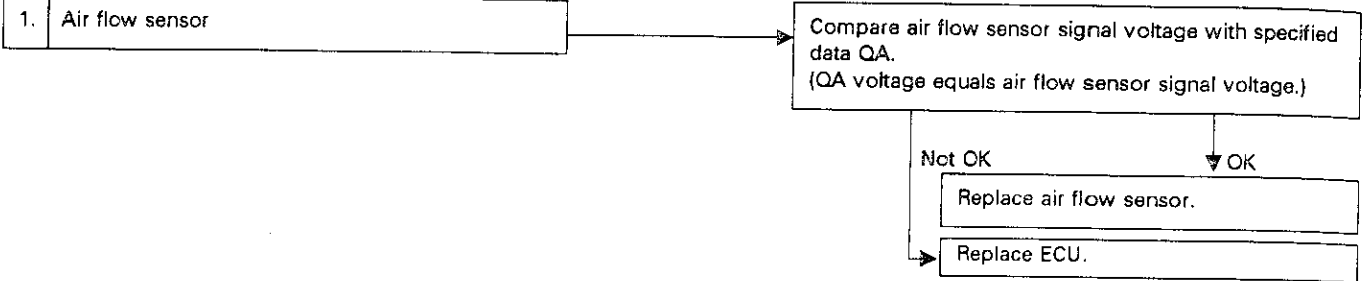


G: MODE F08 — Air flow signal (QA) —

CONDITION:
Idling after warm-up

SPECIFIED DATA:
0.8 — 1.2 V

• Probable cause (if outside specified data)

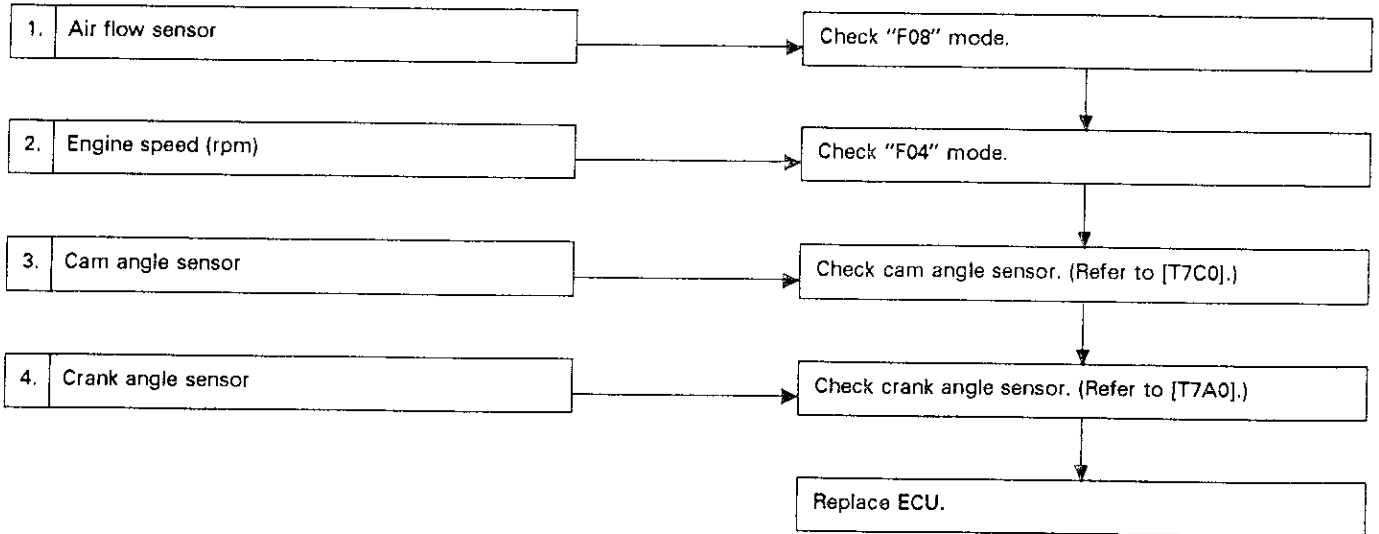


H: MODE F09 — Engine under loads (L DATA) —

CONDITION:
Idling after warm-up

SPECIFIED DATA:
30 — 50

• Probable cause (if outside specified data)

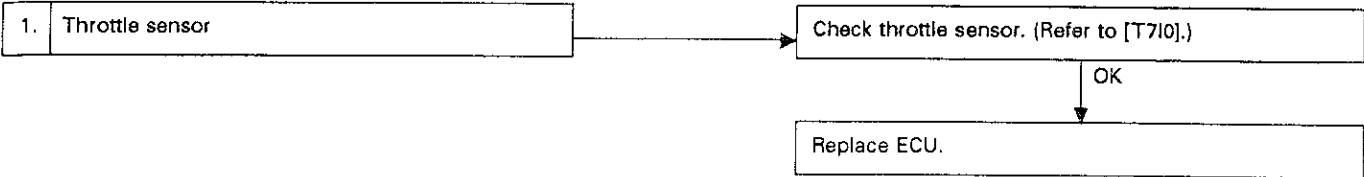


I: MODE F10 — Throttle sensor signal

CONDITION:
Check while changing from "fully-closed" to "fully-open" throttle valve.

SPECIFIED DATA:
4.7 V → 0.9 V *Engine throttle change must be smooth.

● Probable cause (if outside specified data)

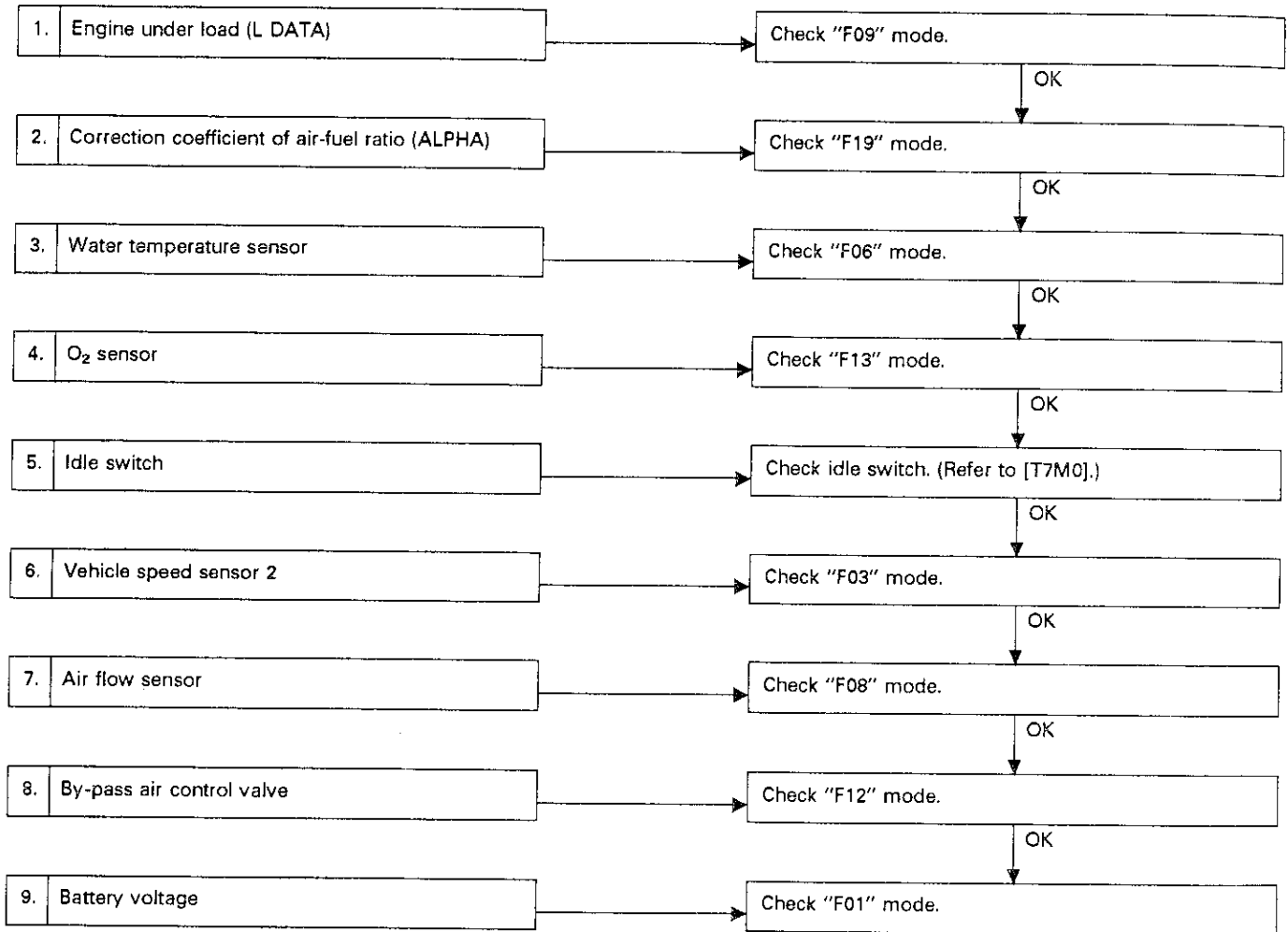


J: MODE F11 — Fuel injection duration (TIM)

CONDITION:
Idling after warm-up

SPECIFIED DATA:
3.0 — 3.7 ms

• Probable cause (if outside specified data)



K: MODE F12 — By-pass air control valve duty (ISC)

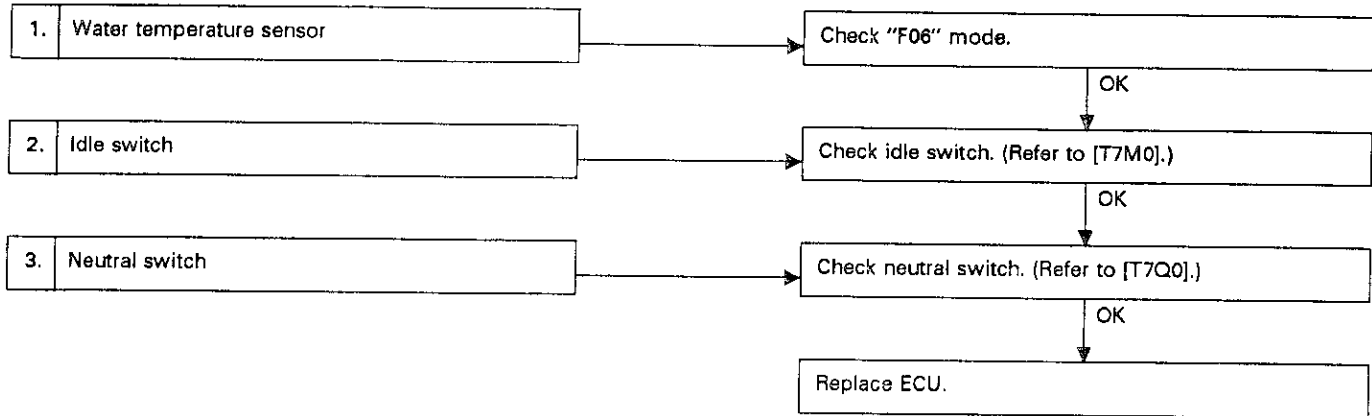
CONDITION:

- (1) Idling after warm-up
- (2) Air conditioner "OFF"
- (3) Radiator fan "OFF"
- (4) Battery voltage: Greater than 13 volts
- (5) Sea level (Not high altitudes)

SPECIFIED DATA:

30 — 45%

• Probable cause (if outside specified data)



L: MODE F13 — O₂ sensor (O₂)

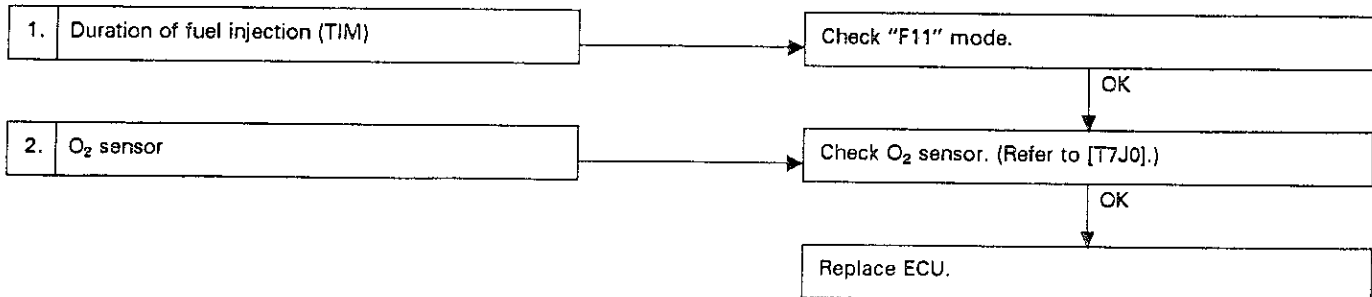
CONDITION:

Idling after warm-up

SPECIFIED DATA:

0.1 — 0.9 V

• Probable cause (if outside specified data)

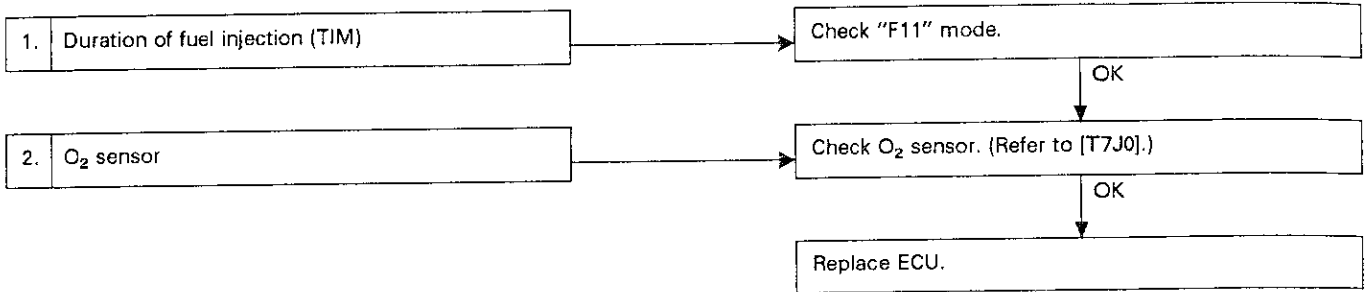


M: MODE F15 — Maximum O₂ sensor signal voltage (O₂ Max.)

CONDITION:
Idling after warm-up

SPECIFIED DATA:
0.7 — 1.0 V

• Probable cause (if outside specified data)

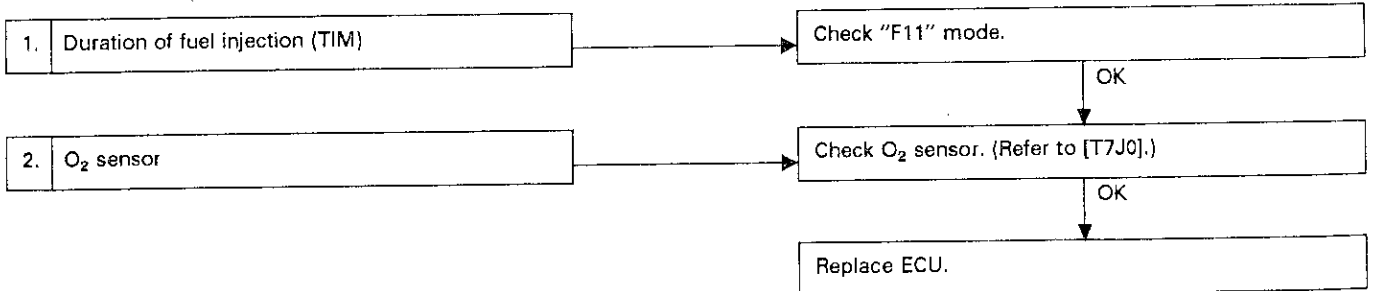


N: MODE F16 — Minimum O₂ sensor signal voltage (O₂ Min.)

CONDITION:
Idling after warm-up

SPECIFIED DATA:
0 — 0.2 V

• Probable cause (if outside data)

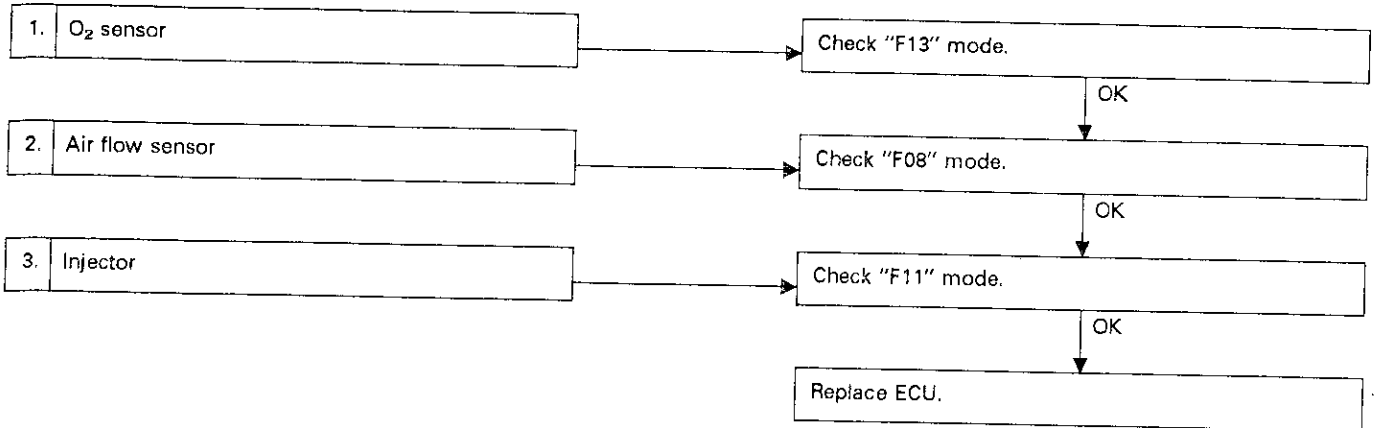


O: MODE F19 — Correction coefficient of air-fuel ratio (ALPHA)

CONDITION:
Idling after warm-up

SPECIFIED DATA:
- 3.2 to + 3.2

● Probable cause (if outside specified data)

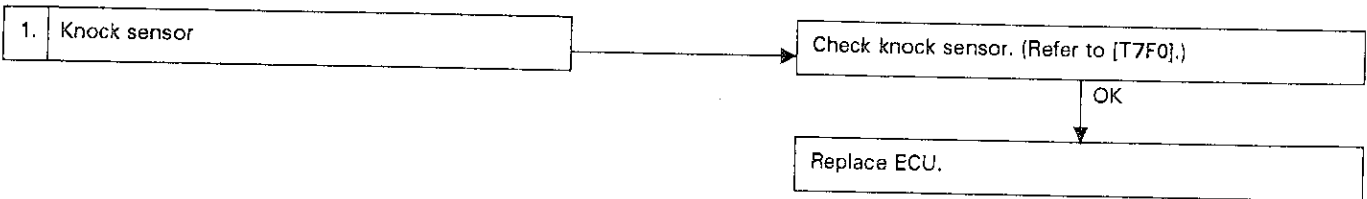


P: MODE F21 — Correction value of ignition timing (RTRD)

CONDITION:
—

SPECIFIED DATA:
- 10 to + 10 deg

● Probable cause (if outside specified data)



Q: MODE F22 — Wastegate control duty (WGC) —

CONDITION:
When engine is running

SPECIFIED DATA:
10 — 70%

• Probable cause (if outside specified data)

1. Atmospheric pressure or
Intake manifold pressure

*Not high altitudes

Check "F23" mode.

OK

Check "F24" mode.

OK

2. Throttle sensor

Check "F10" mode.

OK

Replace ECU.

R: MODE F23 — Atmospheric pressure (BARO. P) —

CONDITION:
Ground surface (not high altitudes)
Engine at idle

SPECIFIED DATA:
*760 mmHg

• Probable cause (if outside specified data)

1. Pressure sensor

*"- 9 to 10 mmHg" changes at an altitude of 100 meters.

Check pressure sensor. (Refer to [T700].)

OK

2. Pressure exchange solenoid valve

Check pressure exchange solenoid valve. (Refer to [T700].)

OK

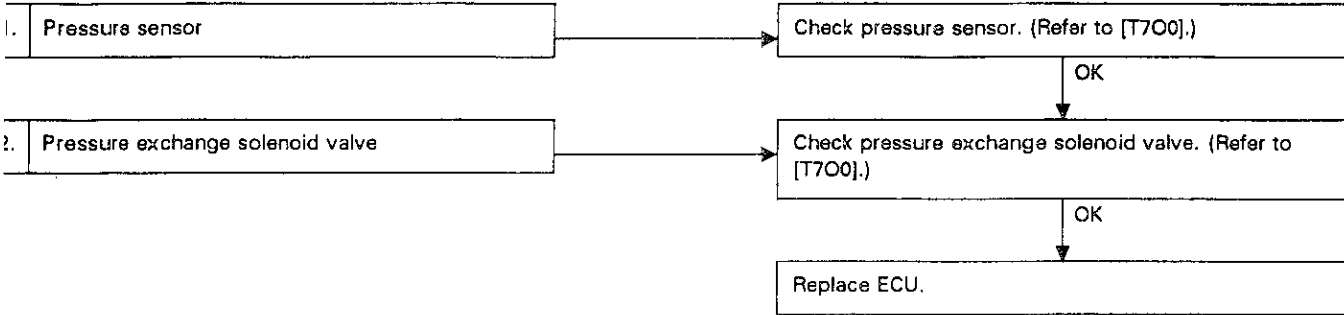
Replace ECU.

MODE F24 — Intake manifold pressure (MANI. P) —

CONDITION:
After warming up, engine at idle

SPECIFIED DATA:
- 400 to - 550 mmHg

Probable cause (if outside specified data)



9. General Troubleshooting Table

Priority of "parts to check" is shown by figures (1, 2, 3, 16).

Parts to check	ECU power supply	Air flow sensor	Water temperature sensor	Idle switch	Throttle sensor	Fuel pump	Pressure regulator	Fuel injector	Igniter (power transistor)	Ignition coil	Spark plug	Knock sensor	Cam angle sensor	Crank angle sensor	Bypass air control valve	O ₂ sensor	Waste-gate control solenoid valve		
Symptom	Initial combustion does not occur.	10	11			5	6	7	2	3	4		8	9					
	Initial combustion occurs.	1	10			2	3	4	5	6	7		8	9	11				
	Engine stalls after initial combustion.	1	2	7		8	4	5	6	11	12	13		9	10	3			
	Failure of engine to start	1	3	12	8	7	4	5	6	9	10	11		13	14	2	15	16	
	Rough idling	1	4	6	8	7	3	2	9	12	13	14		10	11		5	15	
	Hard to drive at constant speed	1	2	6	7	8	3	4	5	13	14	15		11	12	10	10	2	
	Poor acceleration/deceleration	1																	
	Poor return to idle			3	2											1			
	Backfire			3	4	5		6	7					2	1				
	Knocking		1	2				4	5				3		6				7
	Excessive fuel consumption		3	4				1	2										
	Shocks while driving	1	8						7	4	5	6		2	3				
	Poor engine revving		2	3	4	5		1											
Remarks	Include engine grounding circuit.																		
															Check hoses.		Check hoses.		

SUBARU®

1992

**SERVICE
MANUAL**



	Page
M MECHANISM AND FUNCTION	2
1. Fuel Lines	2
2. Fuel Tank	6
3. Fuel Pump	7
4. Jet Pump (4WD model only)	8
5. Fuel Filter	9
S SPECIFICATIONS AND SERVICE DATA	11
C COMPONENT PARTS	12
1. Fuel Tank	12
2. Fuel Lines	14
W SERVICE PROCEDURE	18
1. Precautions	18
2. Fuel Tank	18
3. Fuel Filler Pipe	20
4. Fuel Filter	22
5. Fuel Pump	23
6. Fuel Meter Unit	24
7. Fuel Meter Unit (4WD model only)	25
8. Fuel Separator (4WD model only)	26
9. Fuel Delivery, Return and Evaporation Lines	27
10. Two-way Valve	29
T TROUBLESHOOTING	30

M MECHANISM AND FUNCTION

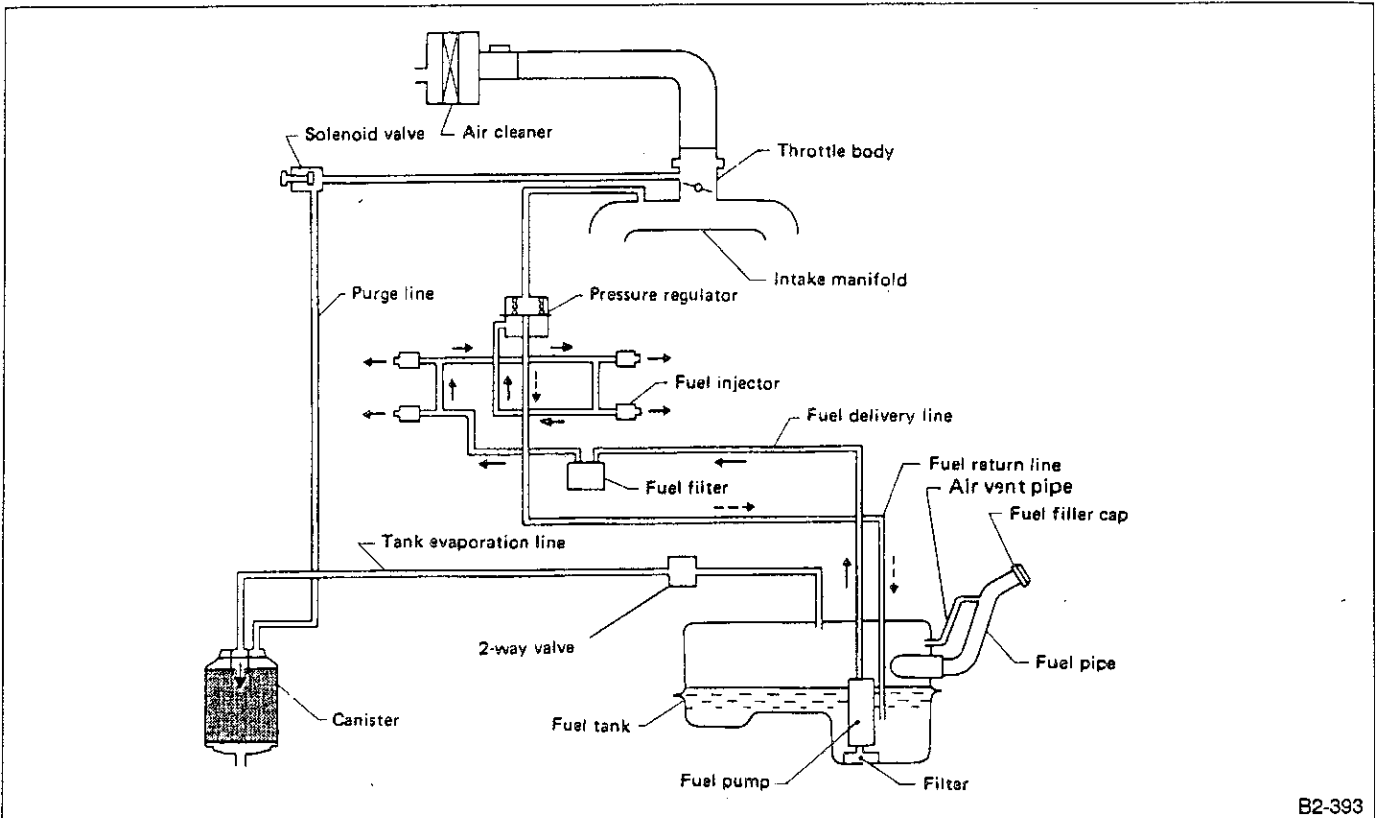
1. Fuel Lines

The fuel lines consist of a delivery line, return line, and an evaporation line. The delivery line supplies fuel from the fuel tank to the intake manifold and consists of a pump filter, fuel pump and fuel filter. On 4WD models, a suction jet pump is used to prevent fuel from remaining in one of the two tank chambers.

The return line returns excess fuel to the fuel tank via the pressure regulator to maintain a constant level of fuel pressure.

The evaporation line consists of a two-way valve, canister, check valve and solenoid valve. On 4WD models, a fuel separator is additionally provided.

1. MPFI



B2-393

Fig. 1 FWD model

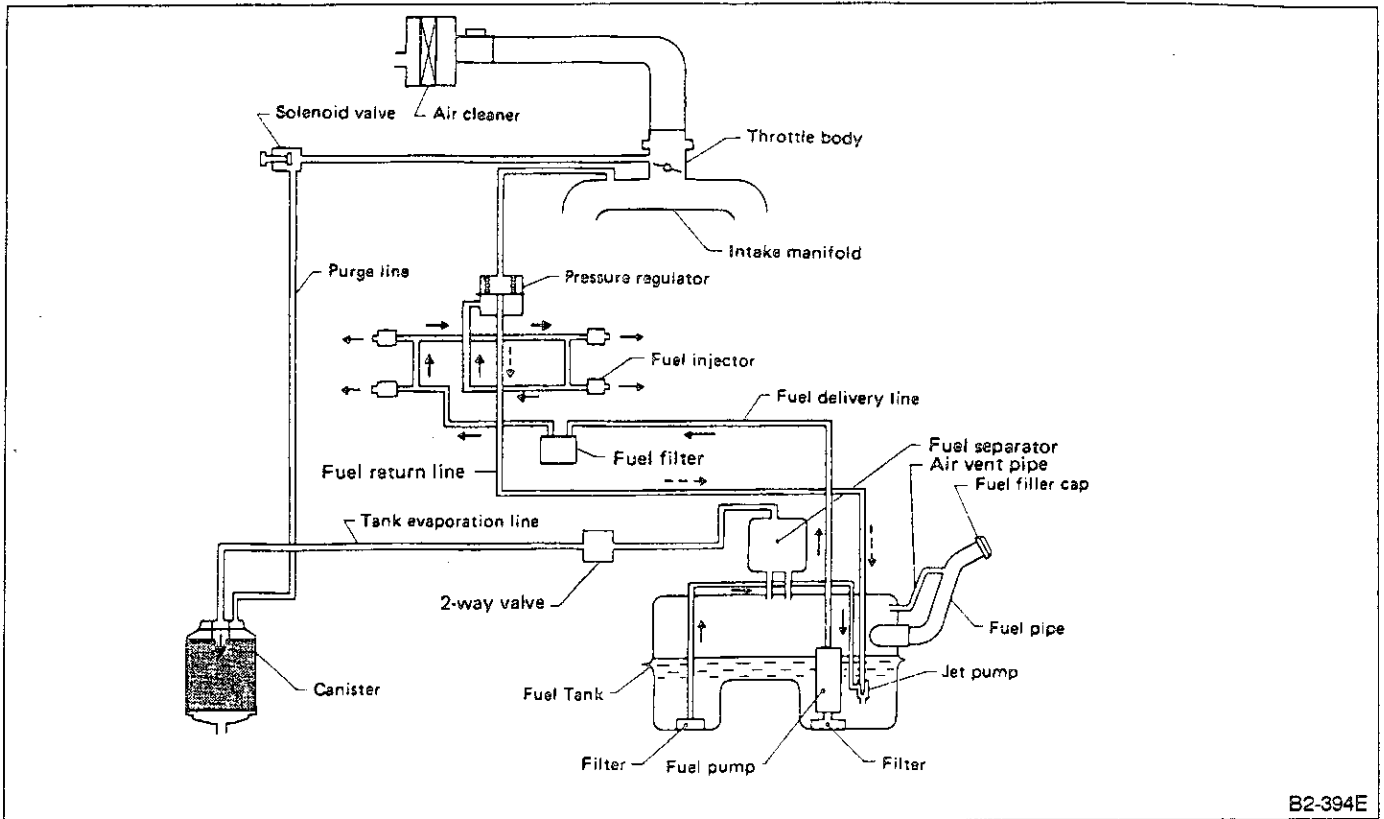


Fig. 2 4WD model

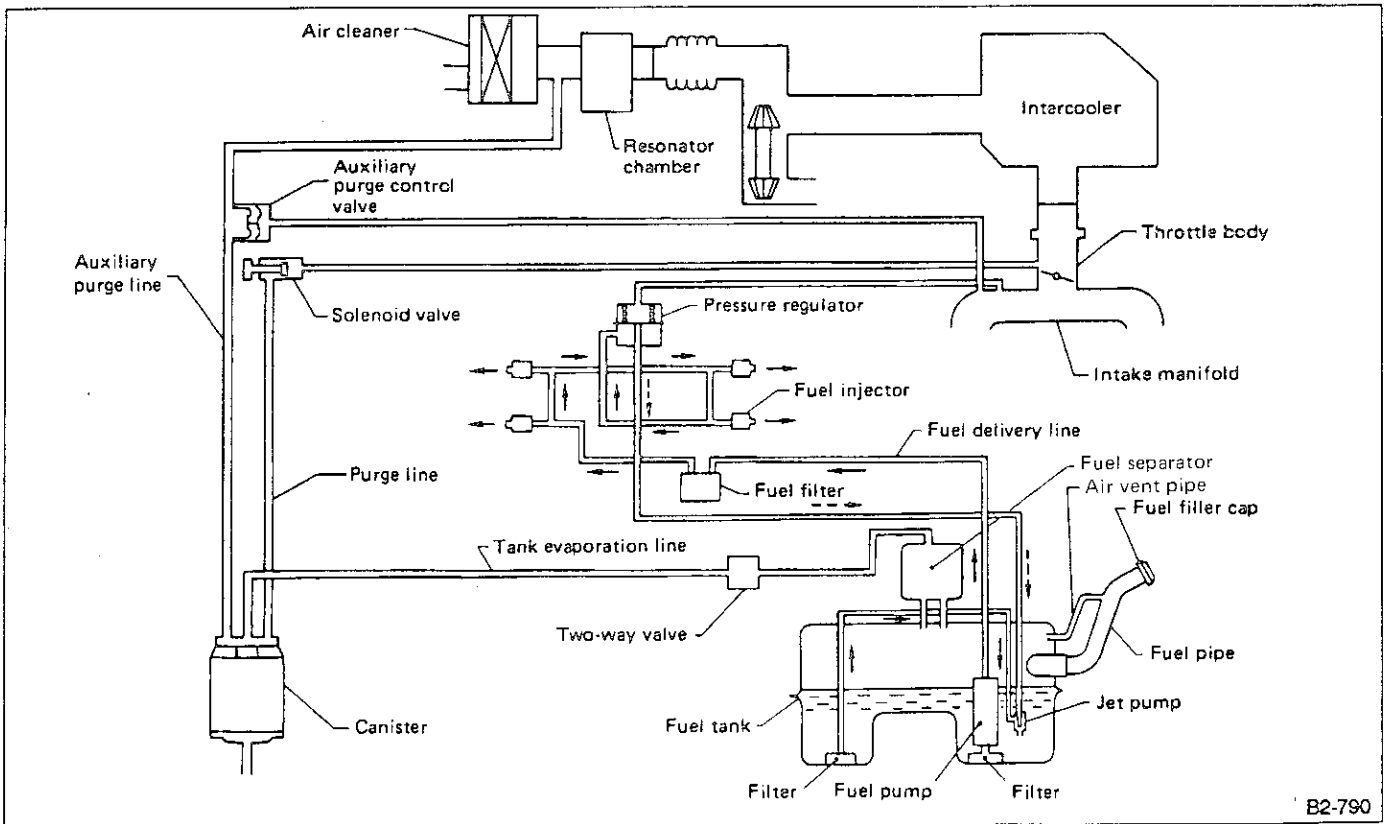


Fig. 3 Turbo model

2. SPFI

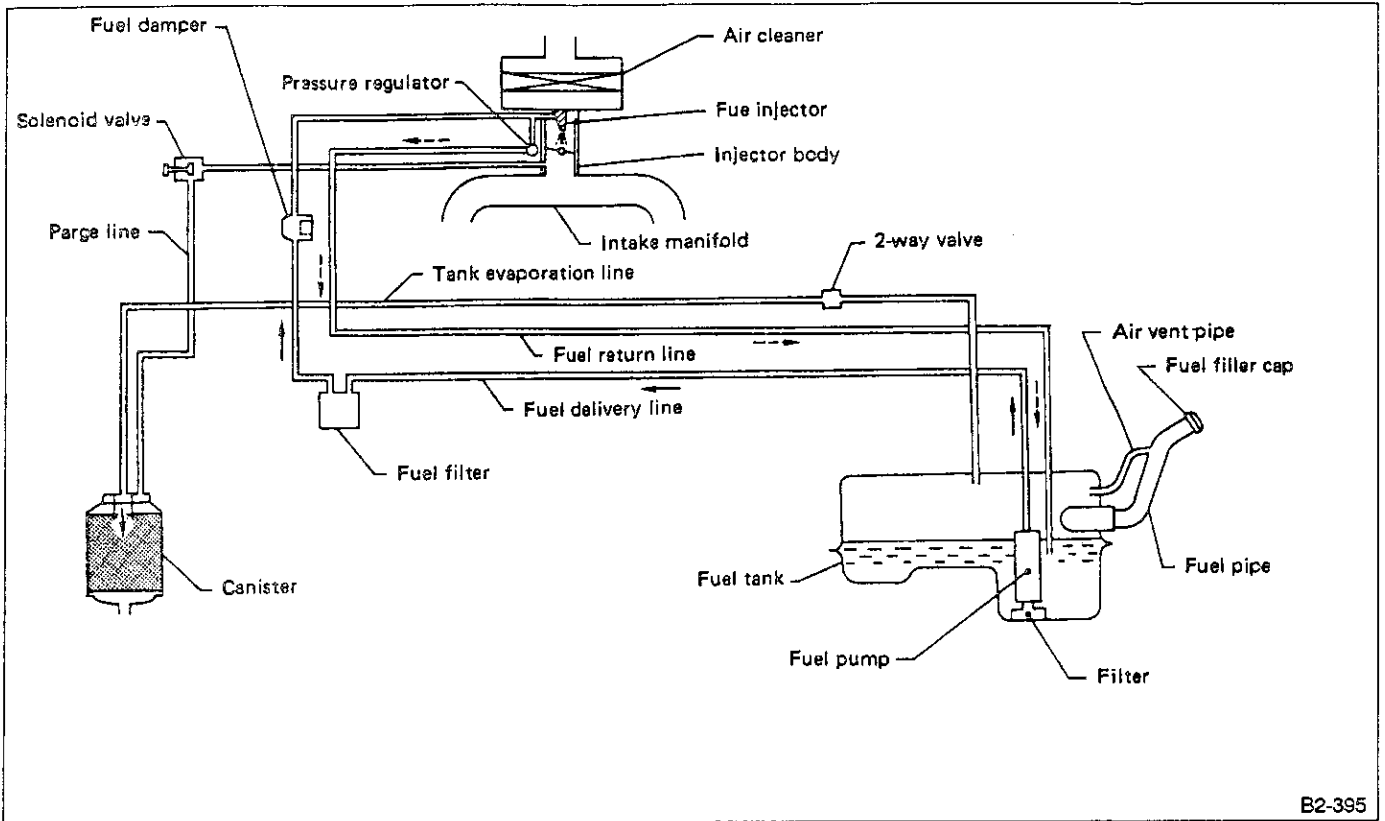


Fig. 4 FWD model

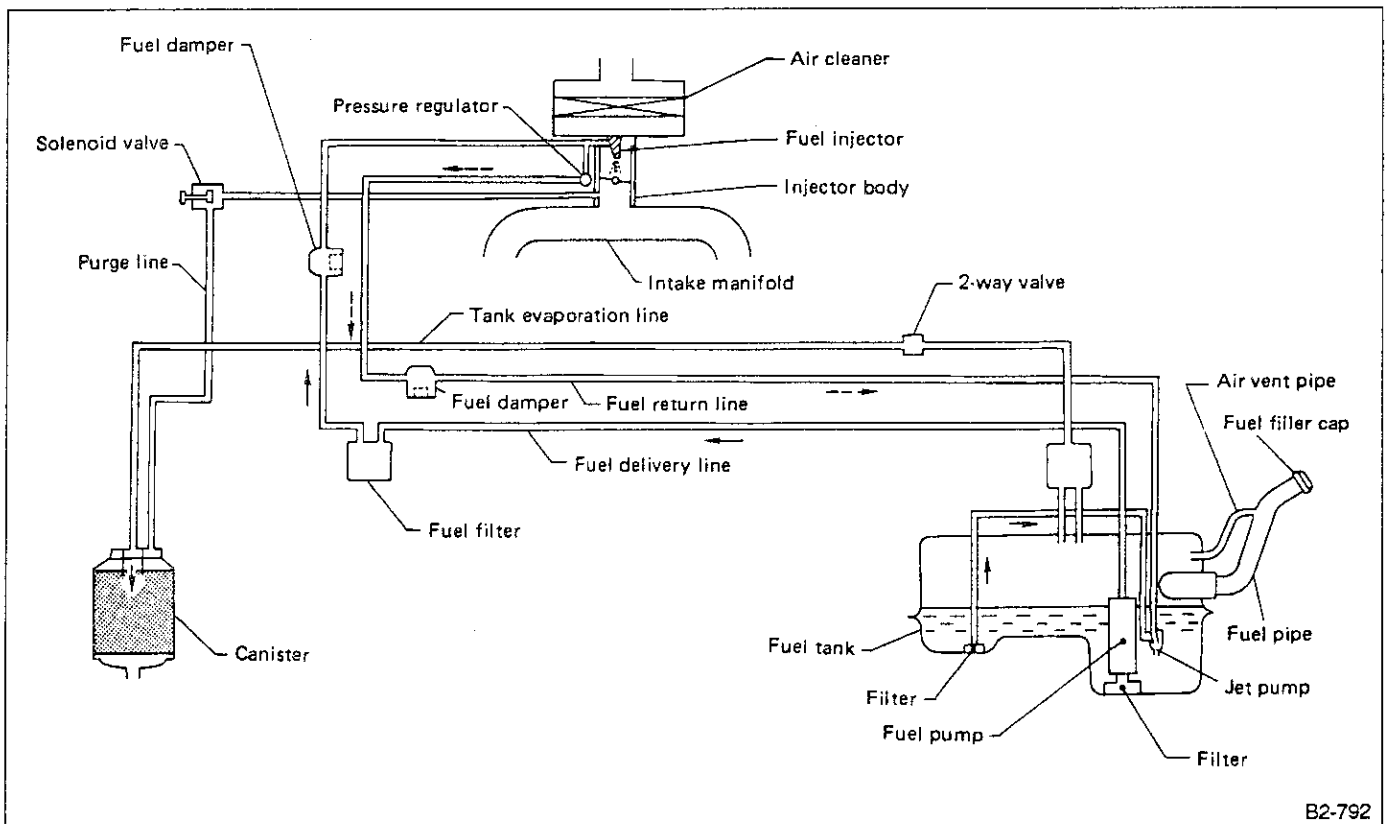


Fig. 5 4WD model

3. CARBURETOR

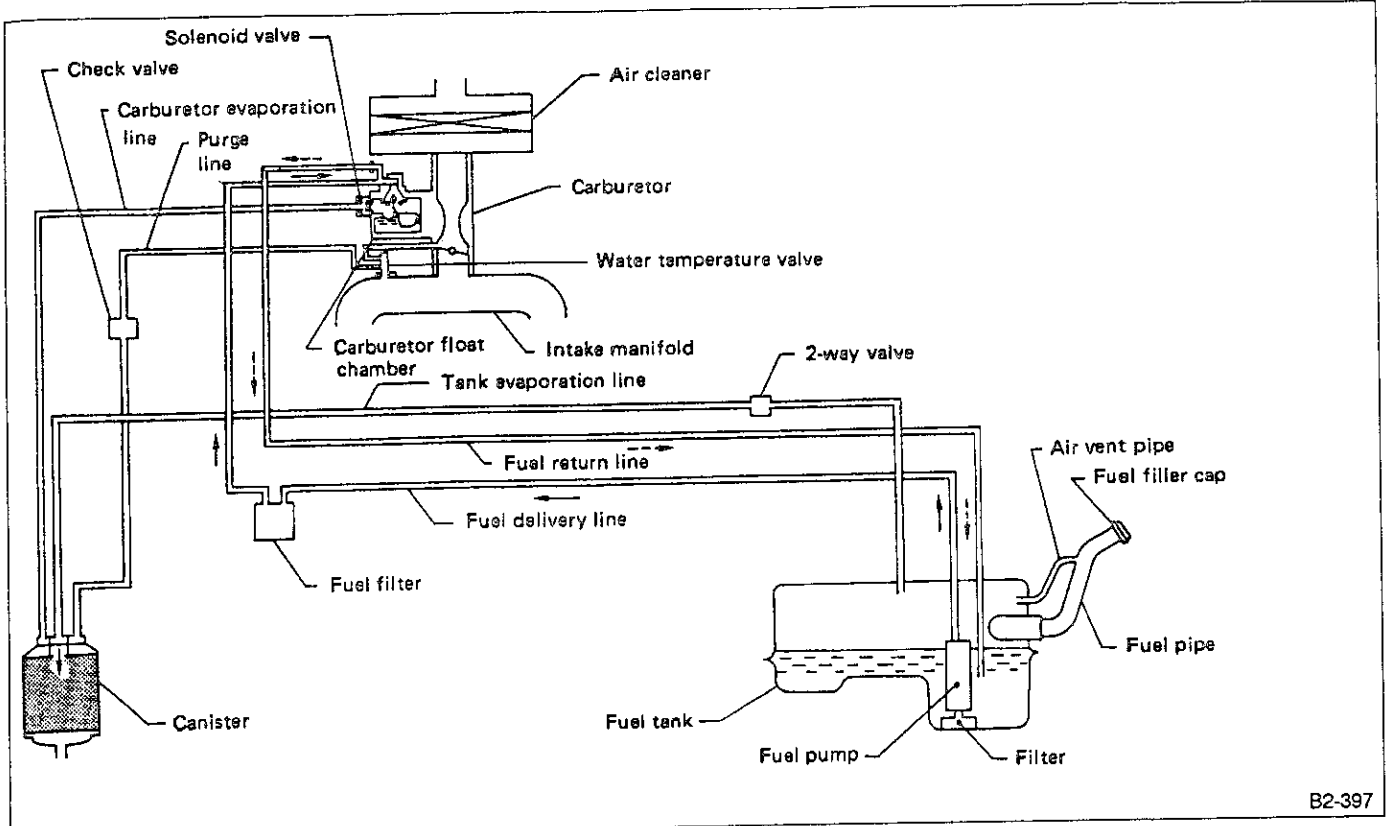


Fig. 6 FWD model

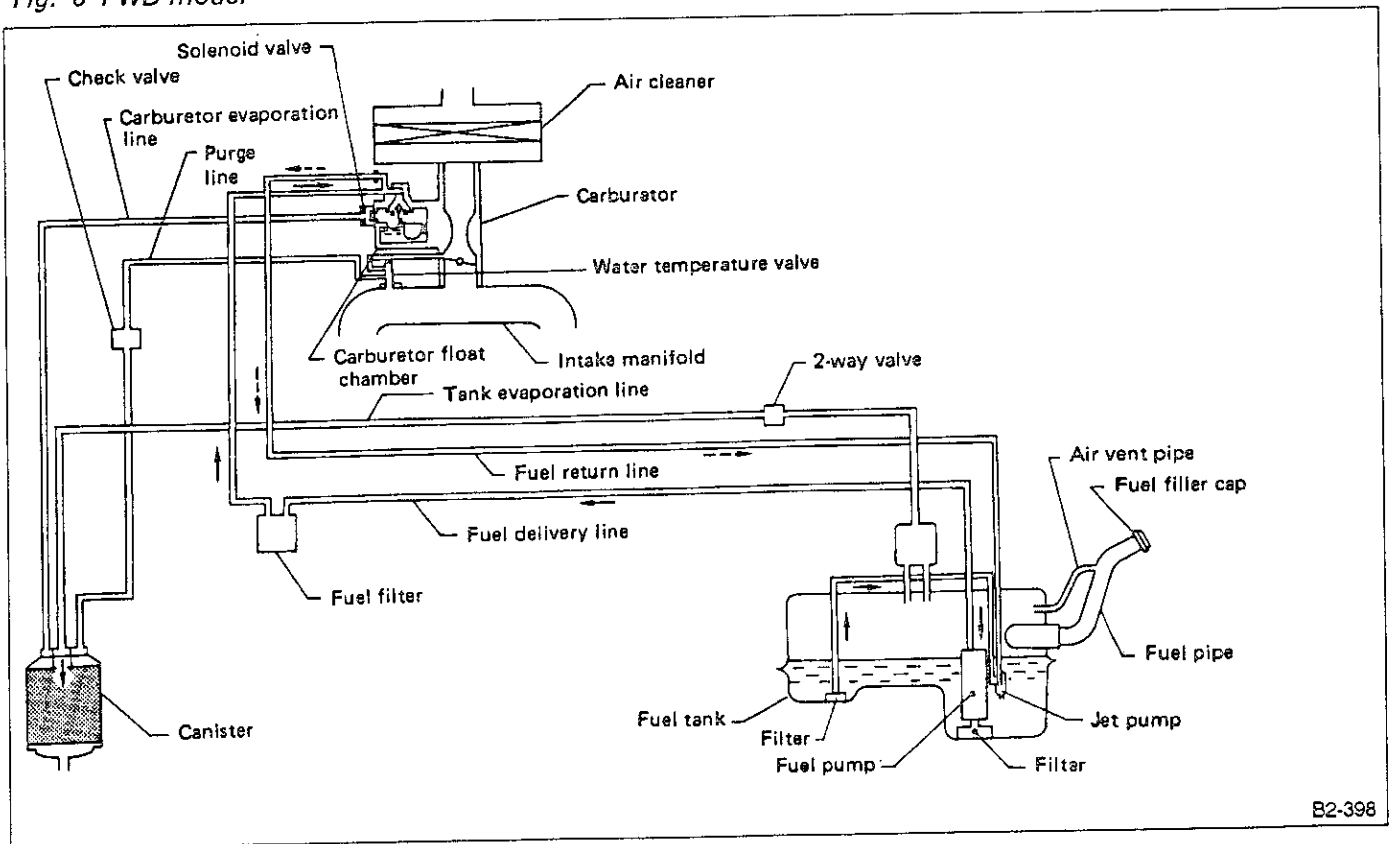


Fig. 7 4WD model

2. Fuel Tank

The fuel tank is located under the rear seat and secured with holddown bands. On 4WD models, the fuel tank utilizes a dented design to prevent interference with the differential.

The fuel tank (for the 4WD model) has two chambers, and is provided with a suction jet pump which transfers

fuel from one chamber to another. These fuel chambers each have a built-in fuel meter unit.

One fuel drain plug is used on the FWD model and two drain plugs are utilized on the 4WD model.

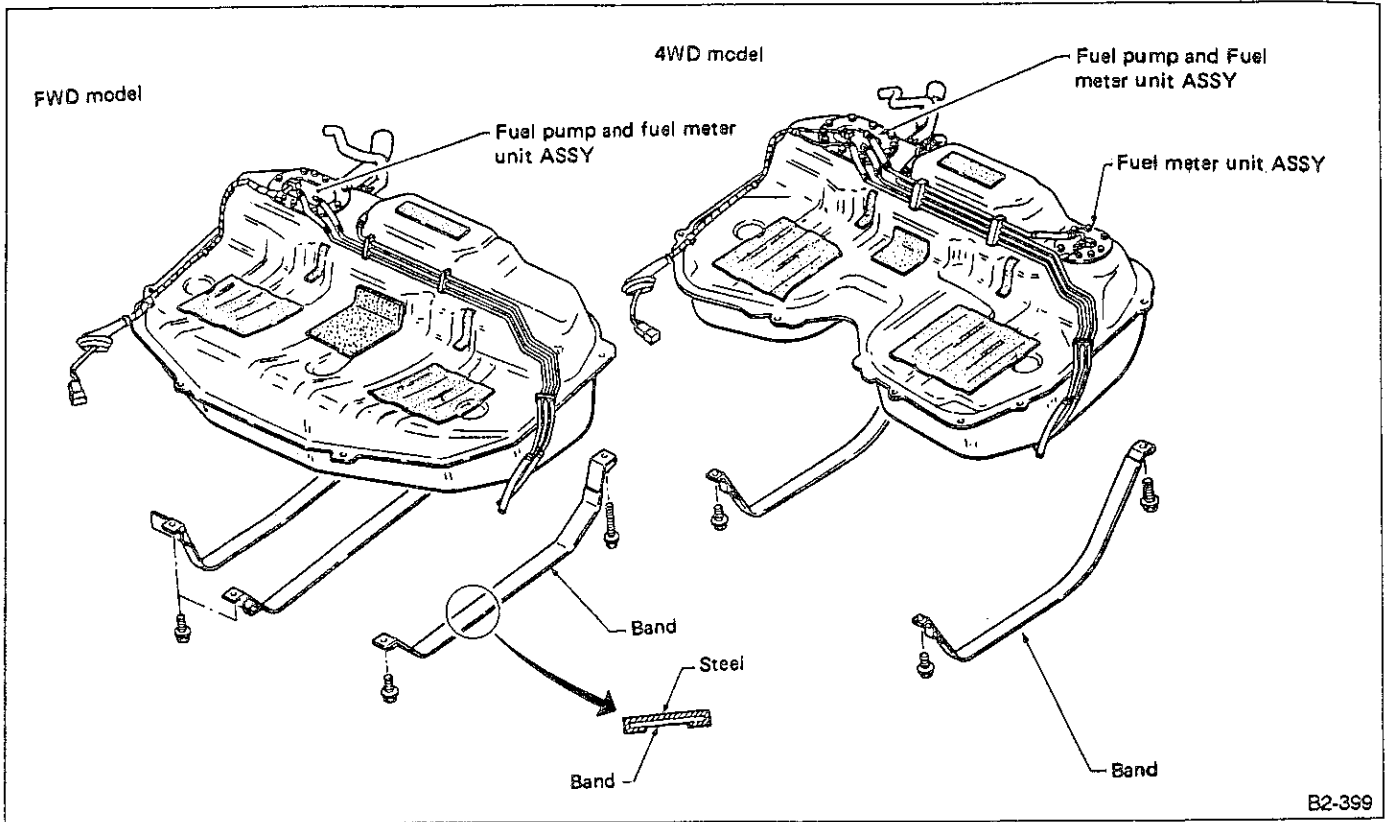


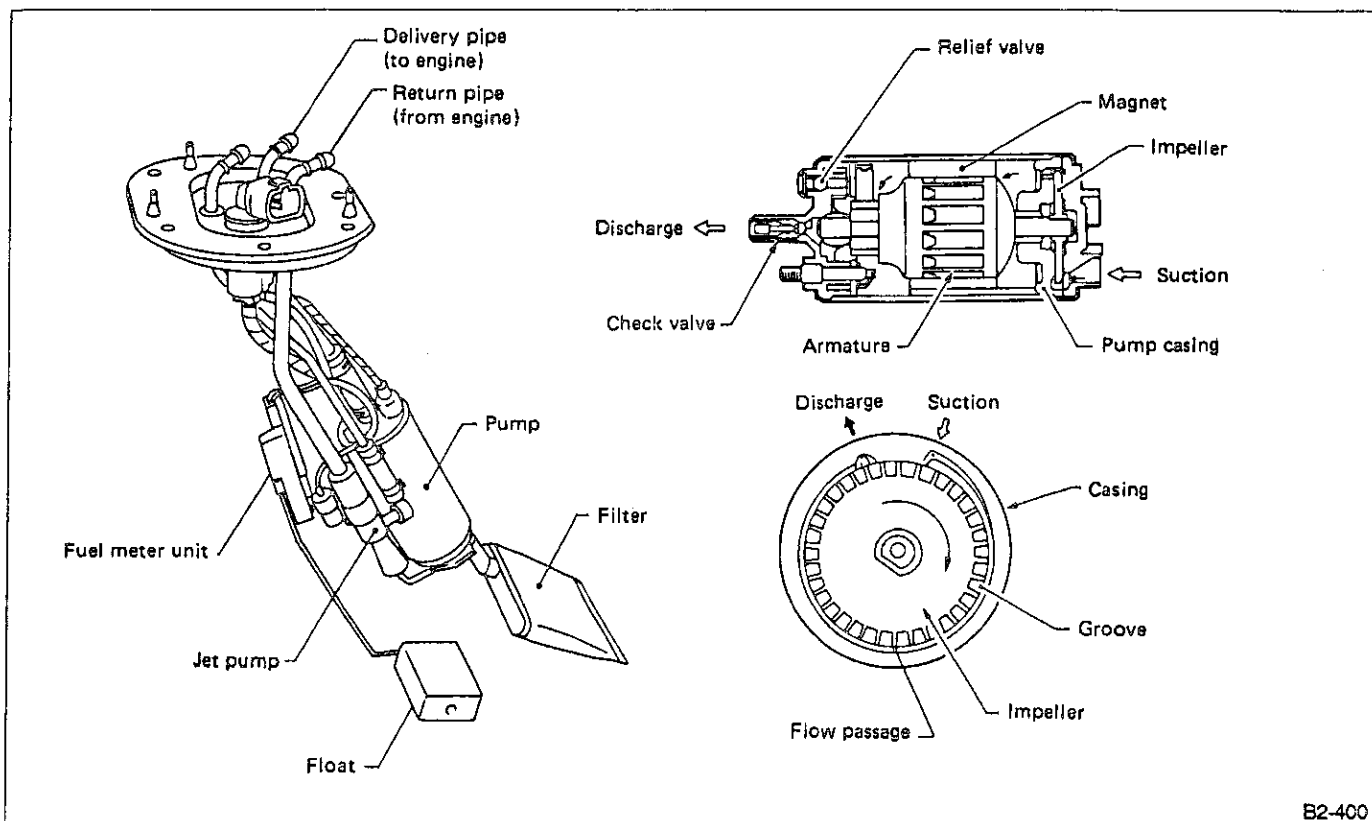
Fig. 8

3. Fuel Pump

A. CONSTRUCTION

The fuel pump is an impeller type. It is built into the fuel tank together with the fuel meter unit to provide quiet operation. The fuel pump consists of a motor, impeller,

pump casing, pump cover, relief valve, check valve and pump filter.



B2-400

Fig. 9

B. OPERATION

- 1) When the engine starts, fuel pump relay activates. This operates the motor to rotate the impeller.
- 2) Fuel entering a vane groove of the impeller flows along the fuel passage and into the next vane groove by centrifugal force. During the time fuel flows from one groove to the next, a pressure differential is produced by friction of the flow.
- 3) Thus, fuel pressure increases while the action is described in step 2) above is repeated, and fuel is discharged from the pump casing. Fuel under pressure then passes through the clearance between the armature and the magnet and is discharged from the fuel pump.

4) As fuel discharge pressure reaches the specified value, the relief valve opens. This discharges fuel under pressure into the fuel tank. Fuel from the fuel tank then returns to the suction port and passes through the fuel pump. This action of fuel flow is repeated. In this manner, the relief valve prevents an abnormal increase in fuel pressure.

5) When the engine and fuel pump stop, spring force acts on the check valve to close the discharge port so that fuel pressure remains in the fuel delivery line.

4. Jet Pump (4WD model only)

This negative pressure allows fuel to be sucked up.

The jet pump utilizes the velocity of fuel returning from the engine to produce negative pressure inside the jet pump.

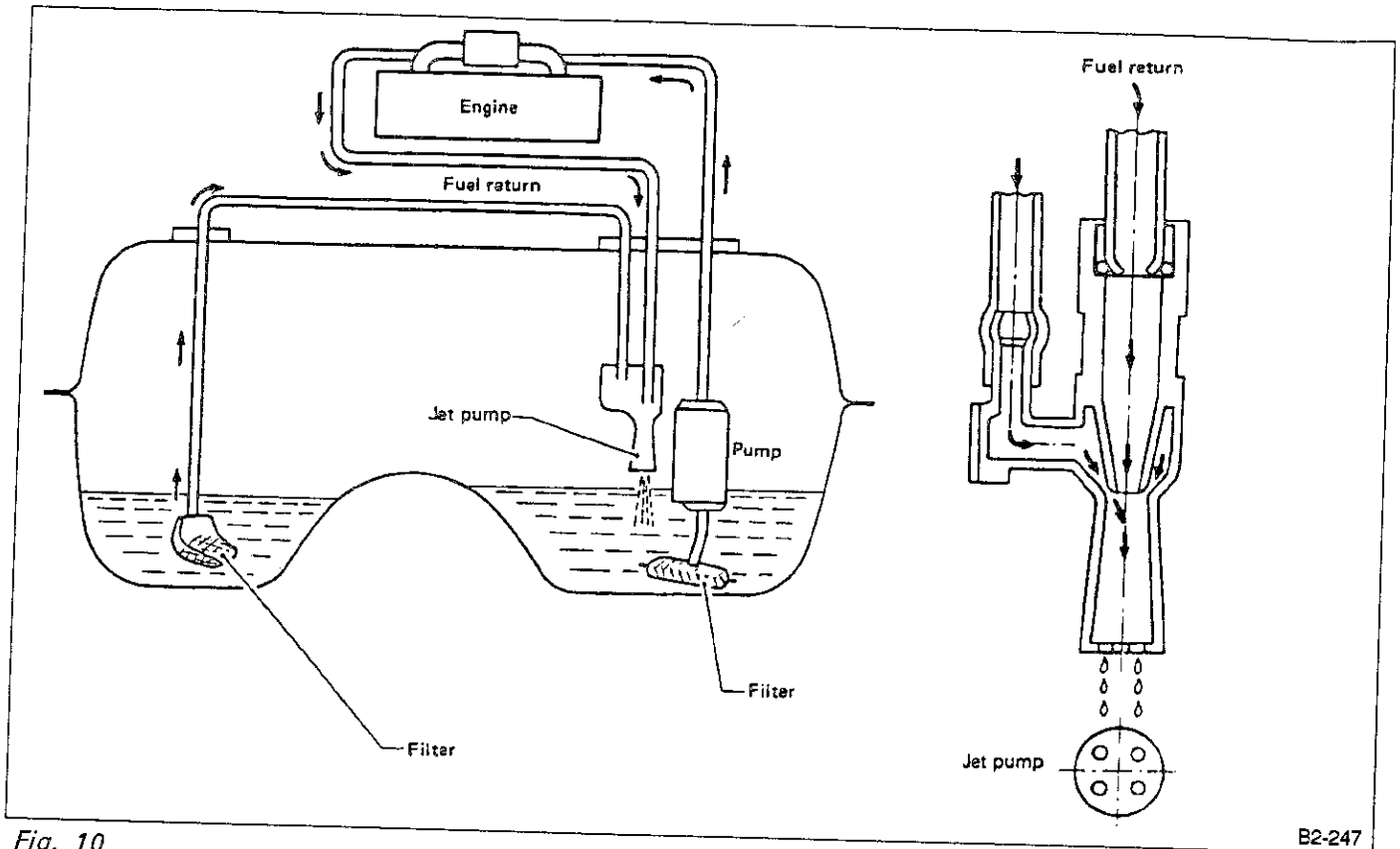


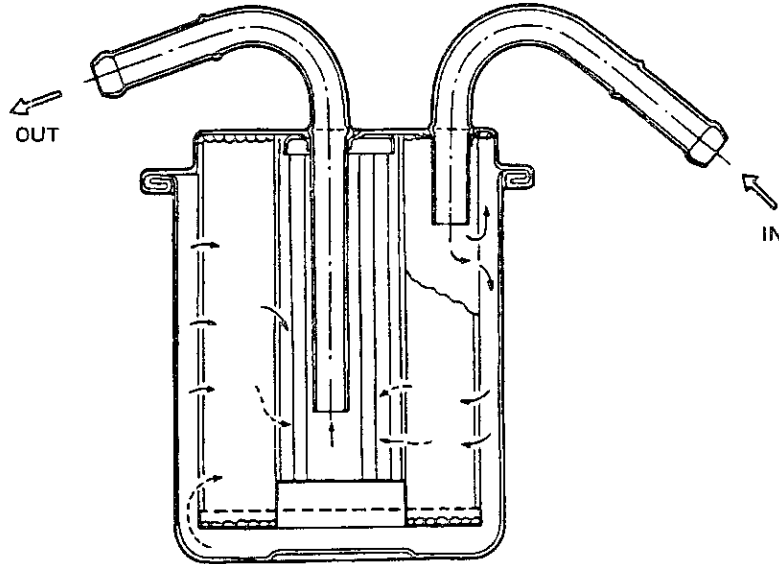
Fig. 10

B2-247

5. Fuel Filter

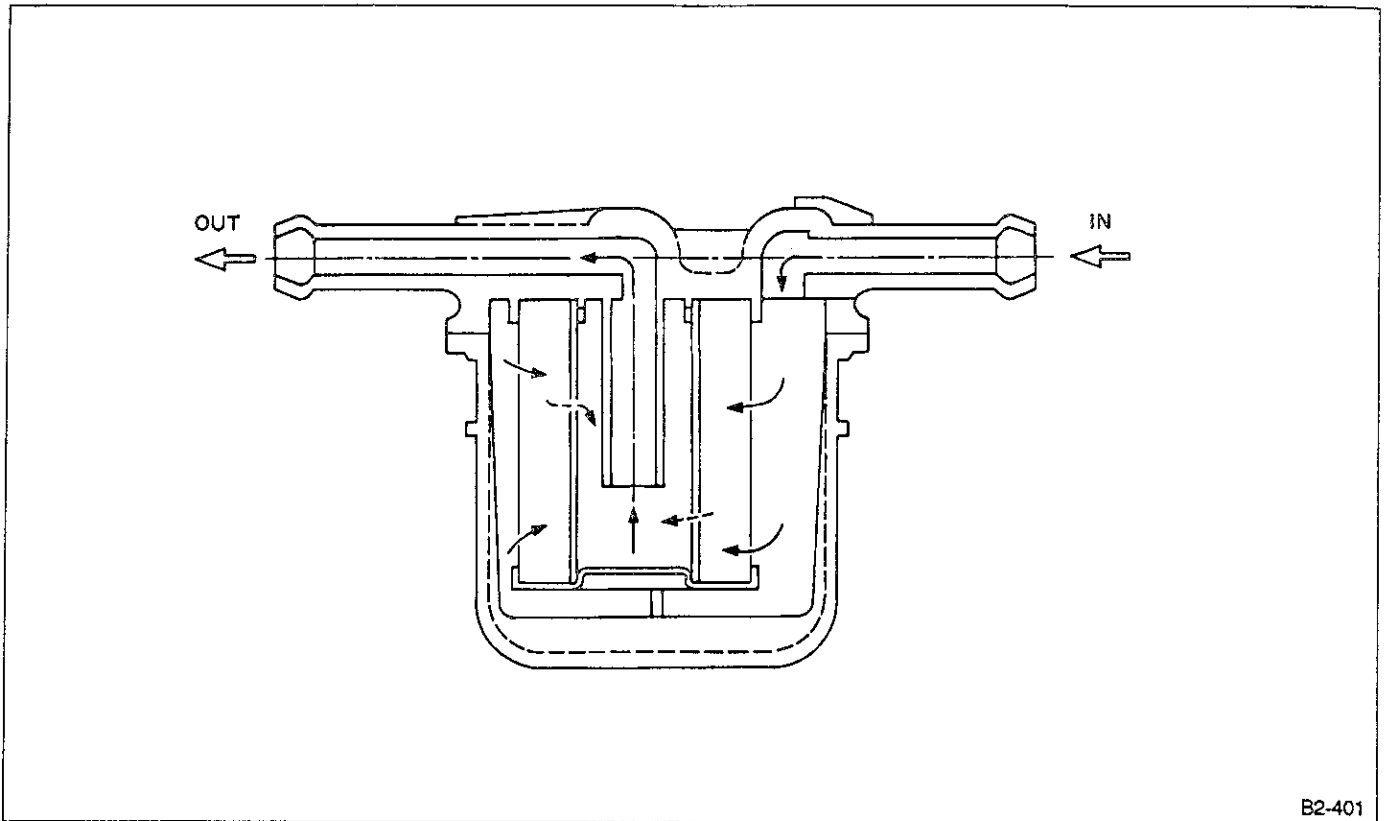
The fuel filter utilizes a pressure-withstanding, cartridge design. It has a filter element built into the metal case.

With this design, fuel flows from the perimeter of the filter element to the interior of the filter.



B2-248

Fig. 11 MPFI (Non-Turbo & Turbo) and SPFI model



B2-401

Fig. 12 Carburetor model

S SPECIFICATIONS AND SERVICE DATA

A: SPECIFICATIONS

1. MPFI Non-TURBO AND SPFI MODELS

Fuel tank	Capacity	60 ℓ (15.9 US gal, 13.2 Imp gal)
	Location	Under rear seat
Fuel pump	Type	Impeller
	Discharge pressure	250.1 kPa (2.55 kg/cm ² , 36.3 psi)
	Discharge flow	More than 80 ℓ (21.1 US gal, 17.6 Imp gal)/h [12 V at 250.1 kPa (2.55 kg/cm ² , 36.3 psi)]
Fuel filter		Cartridge type
Fuel separator	Capacity	1.0 ℓ (1.1 US qt, 0.9 Imp qt)

2. TURBO MODEL

Fuel tank	Capacity	60 ℓ (15.9 US gal, 13.2 Imp gal)
	Location	Under rear seat
Fuel pump	Type	Impeller
	Discharge pressure	299.1 kPa (3.05 kg/cm ² , 43.4 psi)
	Discharge flow	More than 150 ℓ (39.6 US gal, 33.0 Imp gal)/H min. [12 V at 299.1 kPa (3.05 kg/cm ² , 43.4 psi)]
Fuel filter		Cartridge type
Fuel separator	Capacity	1.0 ℓ (1.1 US qt, 0.9 Imp qt)

3. CARBURETOR MODEL

Fuel tank	Capacity	60 ℓ (15.9 US gal, 13.2 Imp gal)
	Location	Under rear seat
Fuel pump	Type	Impeller
	Discharge pressure	17.7 - 23.5 kPa (0.18 - 0.24 kg/cm ² , 2.6 - 3.4 psi)
	Discharge flow	More than 75 - 110 ℓ (19.8 - 29.1 US gal, 16.5 - 24.2 Imp gal)/h [12 V at 17.7 - 23.5 kPa (0.18 - 0.24 kg/cm ² , 2.6 - 3.4 psi)]
Fuel filter		Cartridge type
Fuel separator	Capacity	1.0 ℓ (1.1 US qt, 0.9 Imp qt)

C COMPONENT PARTS

1. Fuel Tank

A: FWD MODEL

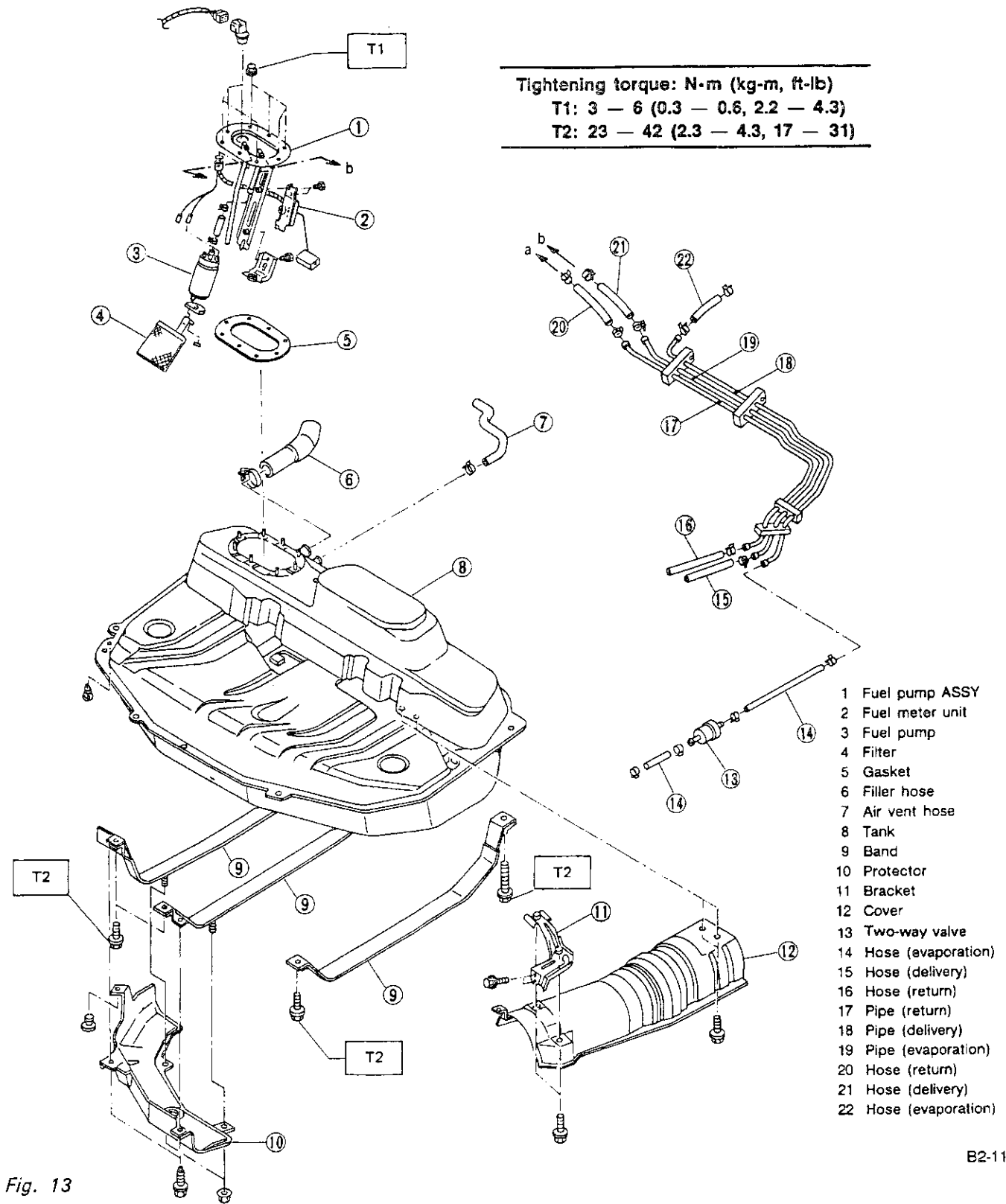


Fig. 13

B: 4WD MODEL

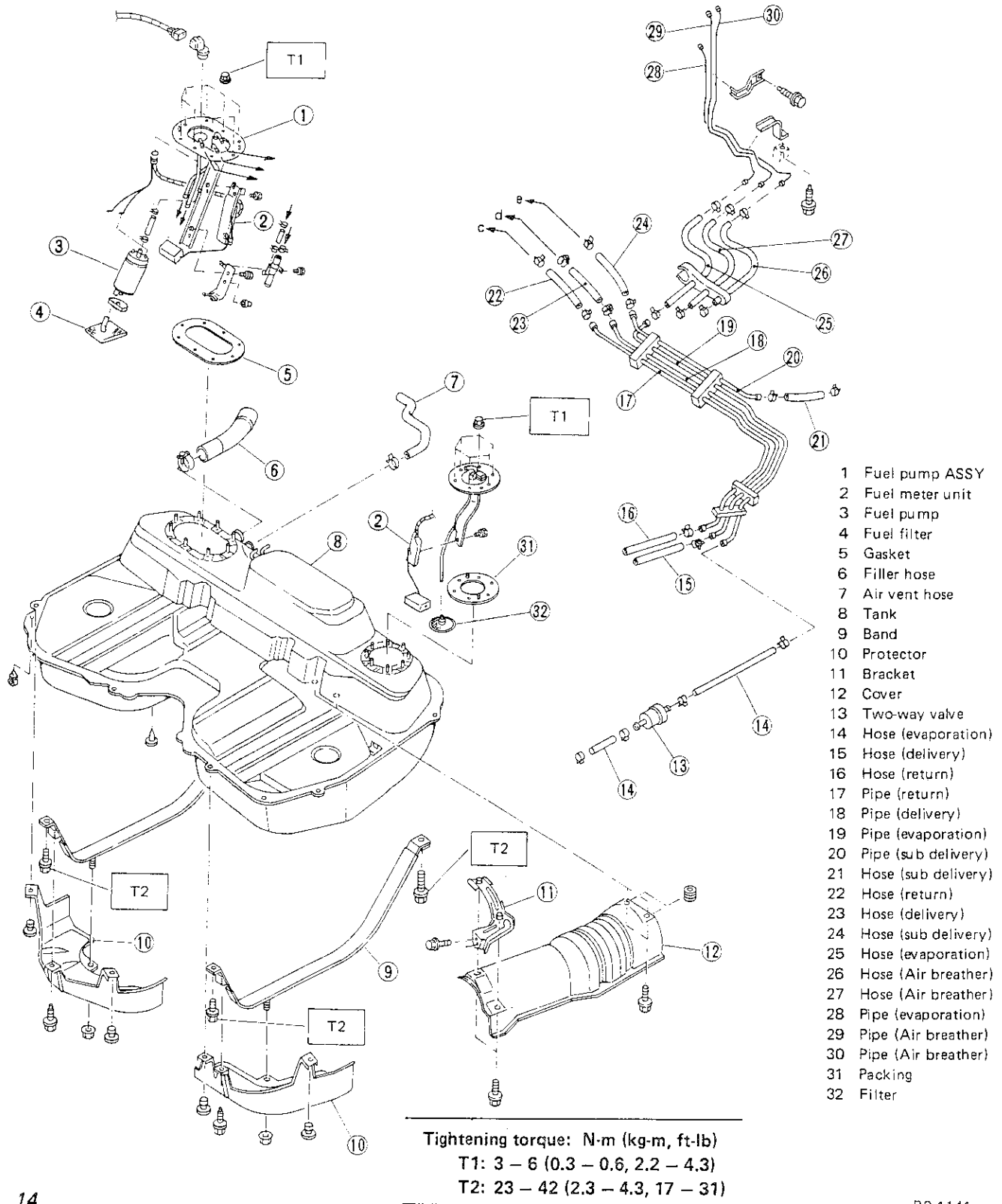


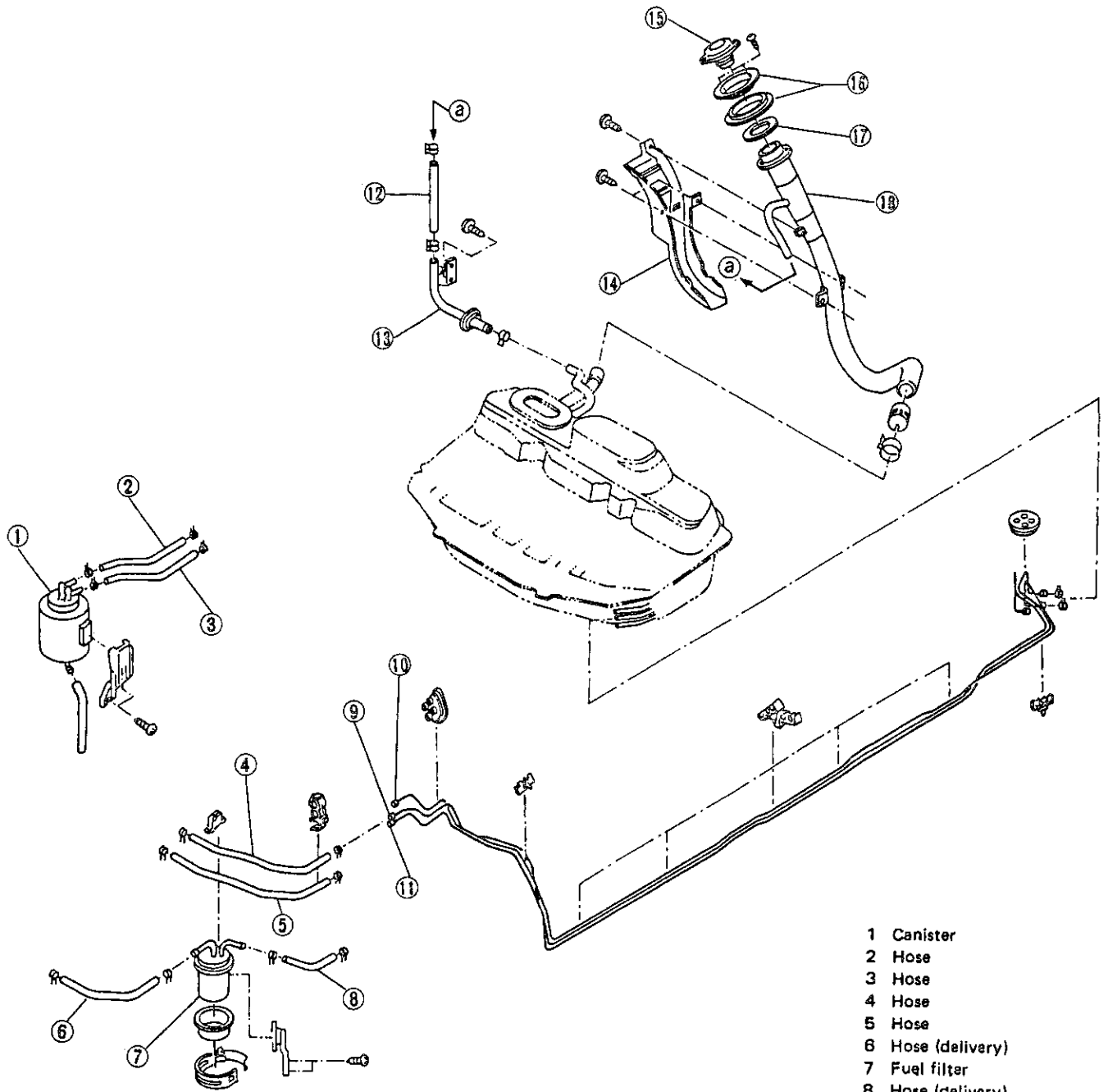
Fig. 14

B2-1141

2. Fuel Lines

A: FWD MODEL

1. MPFI AND SPFI MODELS

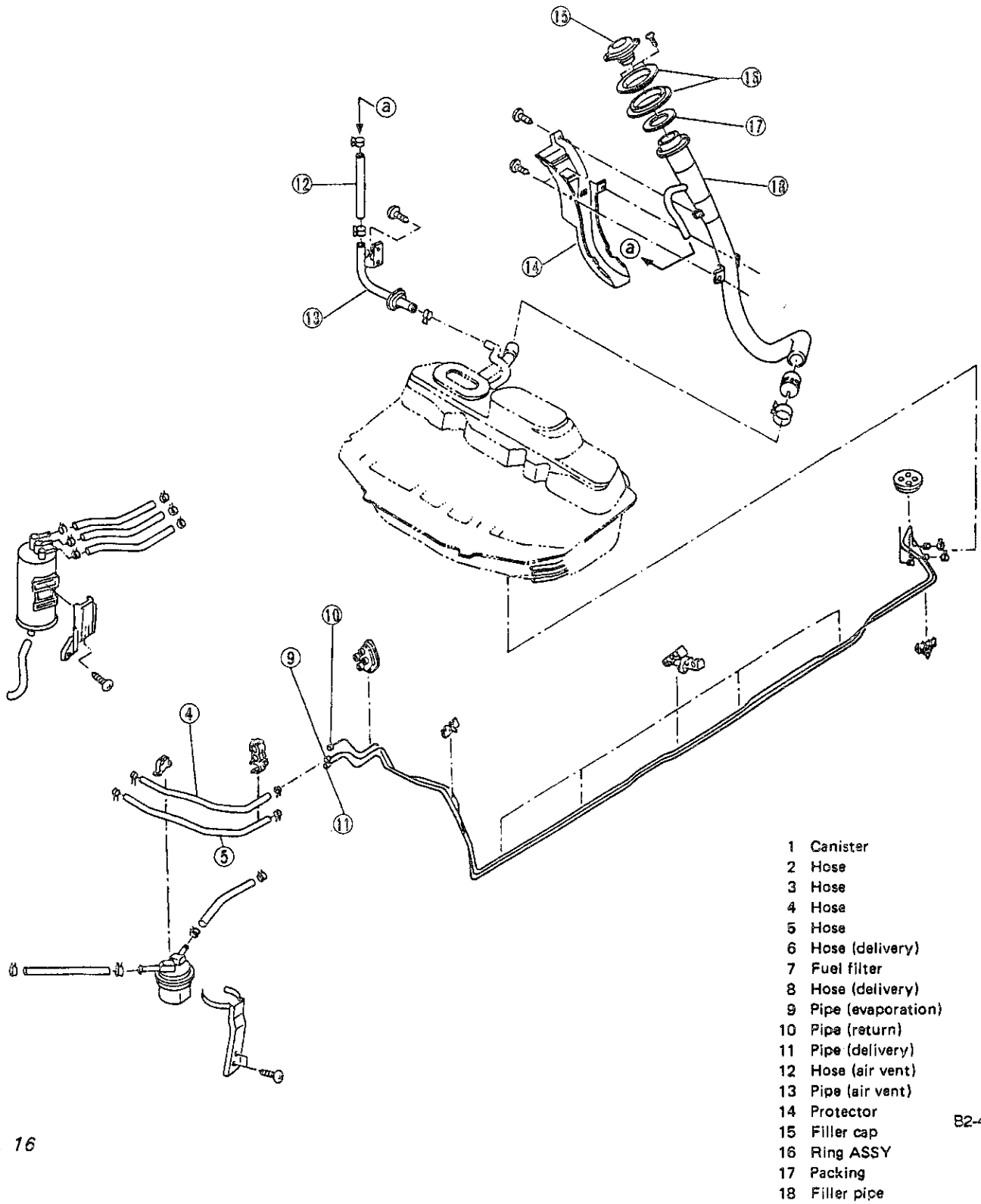


- 1 Canister
- 2 Hose
- 3 Hose
- 4 Hose
- 5 Hose
- 6 Hose (delivery)
- 7 Fuel filter
- 8 Hose (delivery)
- 9 Pipe (evaporation)
- 10 Pipe (return)
- 11 Pipe (delivery)
- 12 Hose (air vent)
- 13 Pipe (air vent)
- 14 Protector
- 15 Filler cap
- 16 Ring ASSY
- 17 Packing
- 18 Filler pipe

Fig. 15

B2-404

2. CARBURETOR MODEL



B2-405

Fig. 16

B: 4WD MODEL

1. MPFI AND SPFI MODELS

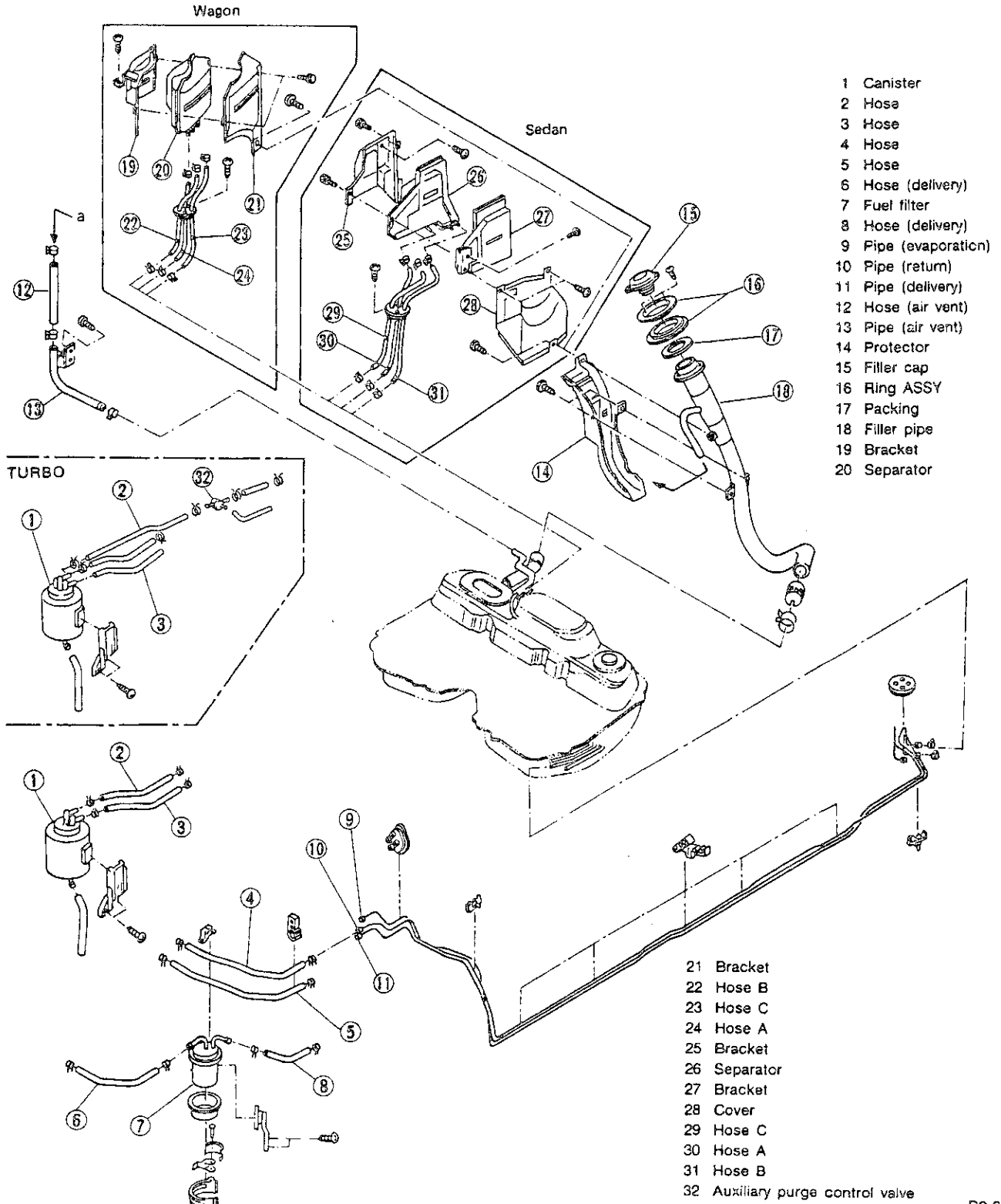
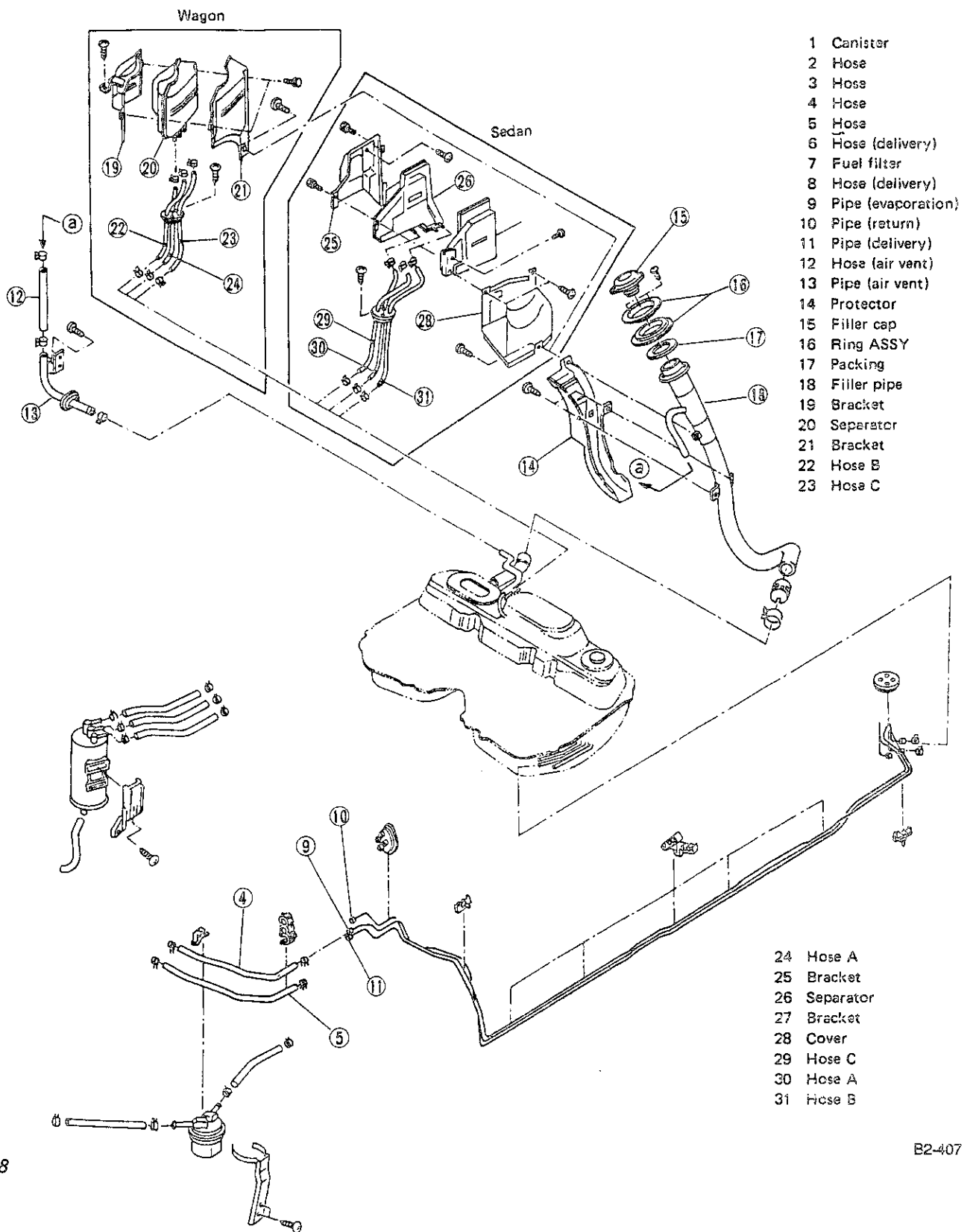


Fig. 17

B2-561

2. CARBURETOR MODEL



- 1 Canister
- 2 Hose
- 3 Hose
- 4 Hose
- 5 Hose
- 6 Hose (delivery)
- 7 Fuel filter
- 8 Hose (delivery)
- 9 Pipe (evaporation)
- 10 Pipe (return)
- 11 Pipe (delivery)
- 12 Hose (air vent)
- 13 Pipe (air vent)
- 14 Protector
- 15 Filler cap
- 16 Ring ASSY
- 17 Packing
- 18 Filler pipe
- 19 Bracket
- 20 Separator
- 21 Bracket
- 22 Hose B
- 23 Hose C

- 24 Hose A
- 25 Bracket
- 26 Separator
- 27 Bracket
- 28 Cover
- 29 Hose C
- 30 Hose A
- 31 Hose B

Fig. 18

B2-407

W SERVICE PROCEDURE

1. Precautions

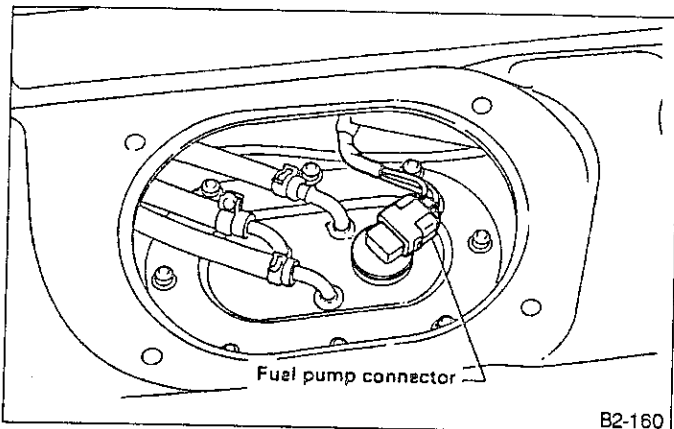
a. Before starting the job, be sure to carry out the following.

- 1) Place "No fire" signs near the working area.
- 2) Disconnect ground cable from battery.

b. Be careful not to spill fuel on the floor.

1. RELEASING OF FUEL PRESSURE

- 1) Fold down the rear seat back, and turn up the floor mat.
- 2) Remove access hole lid.
- 3) Disconnect fuel pump connector.



B2-160

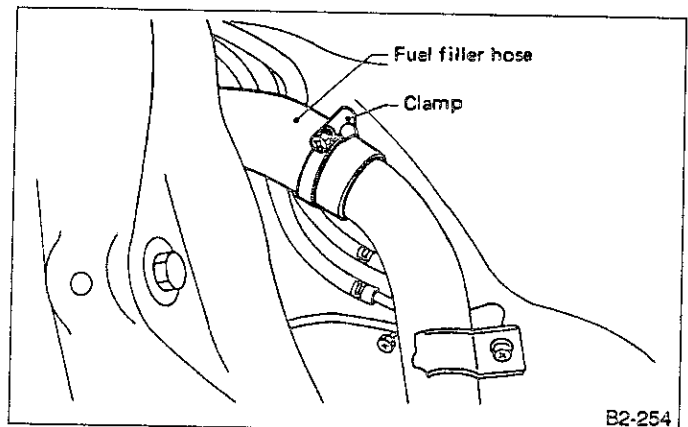
Fig. 19

- 4) Start the engine, and run it until it stalls.
- 5) After the engine has stalled, crank it for five more seconds.
- 6) Turn ignition switch "OFF".

2. Fuel Tank

A: REMOVAL

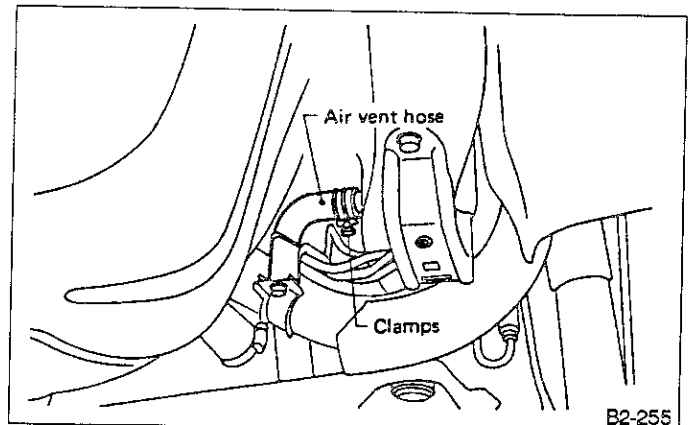
- 1) Release fuel pressure.
- Refer to Section 1. [W101]
- 2) Drain fuel from tank.
 - 3) Remove muffler, rear suspension crossmember and rear differential ASSY. (4WD model only)
 - 4) Remove fuel filler cap and drain fuel from fuel tank.
 - 5) Remove clamp and disconnect fuel filler hose from fuel filler pipe.



B2-254

Fig. 20

- 6) Remove clamp and disconnect air vent hose from fuel filler pipe.



B2-255

Fig. 21

7) Loosen clips and disconnect air breather hoses and evaporation hose from pipes. (4WD model only)

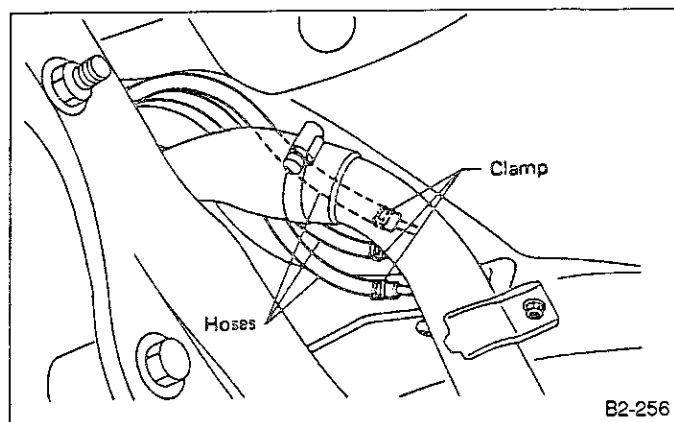


Fig. 22

8) Loosen clips and clamp, and disconnect delivery hose, return hose and evaporation hose from pipes.

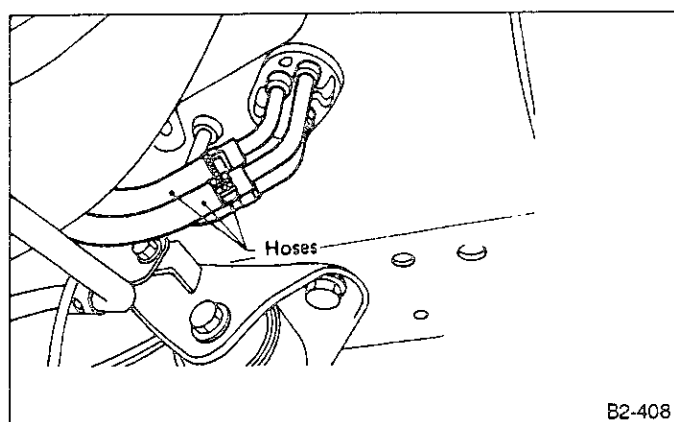


Fig. 23

9) While holding fuel tank, remove bolts from bands and dismount fuel tank.

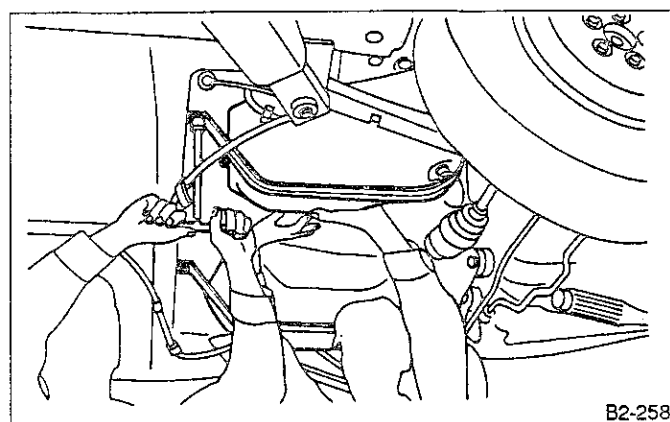


Fig. 24

Two men are required to perform step 7) above.

10) Disconnect harness connector from fuel pump ASSY.

On 4WD models, also disconnect harness connector from fuel meter unit.

Have a helper support fuel tank, when disconnecting harness.

B: INSTALLATION

Installation is in the reverse order of removal procedures. Observe the following:

- 1) When installing fuel tank, have a helper hold fuel tank while connecting hoses and harness connector.
- 2) Before tightening band mounting bolts, make sure hoses, harnesses, etc. are not caught between fuel tank and car body.
- 3) Install hose and tube holddown clips at positions indicated in the figure.

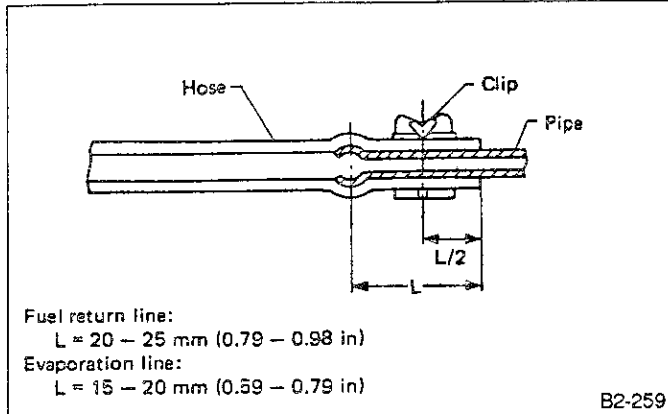


Fig. 25

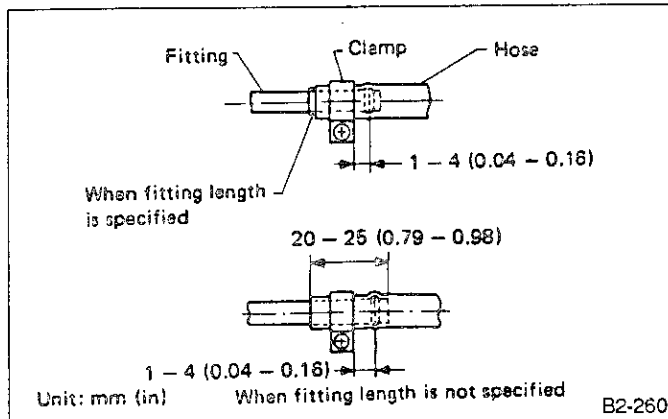


Fig. 26

Tightening torque:
1.0 - 1.5 N·m (0.1 - 0.15 kg-m, 0.7 - 1.1 ft-lb)

3. Fuel Filler Pipe

A: REMOVAL

- 1) Open fuel filler flap and remove filler cap.
- 2) Completely drain fuel from fuel tank.
- 3) Remove right rear tire.
- 4) Remove three screws holding packing in place.

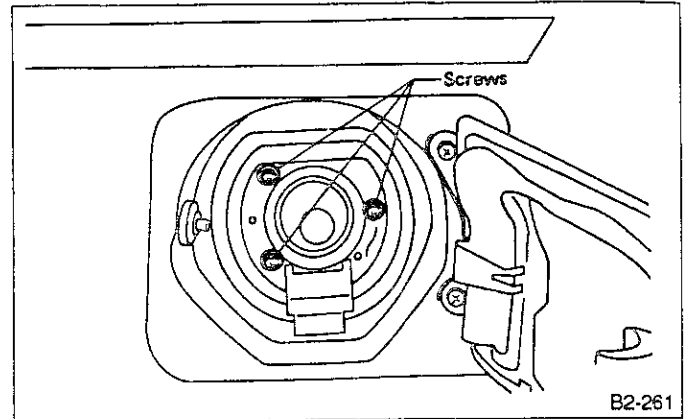


Fig. 27

- 5) Remove fuel filler pipe protector.

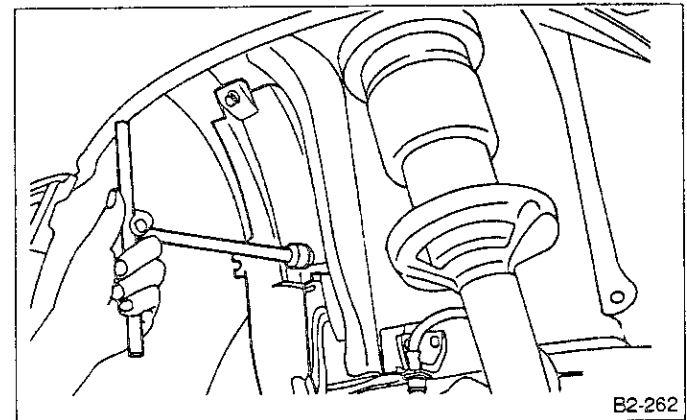


Fig. 28

6) Remove clips and disconnect fuel filler hose and air vent hose from fuel filler pipe.

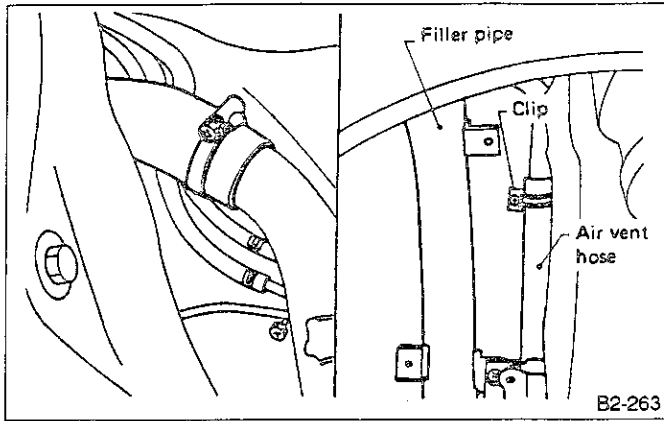


Fig. 29

7) Disconnect fuel filler pipe from underside of car. Place a container under pipe connection to catch fuel which may remain in filter pipe.

B: INSTALLATION

1) Hold fuel filler flap open.
 2) Insert fuel filler pipe into hole in fuel saucer from the inner side of apron. Align holes in fuel filler pipe neck and packing and tighten screws.

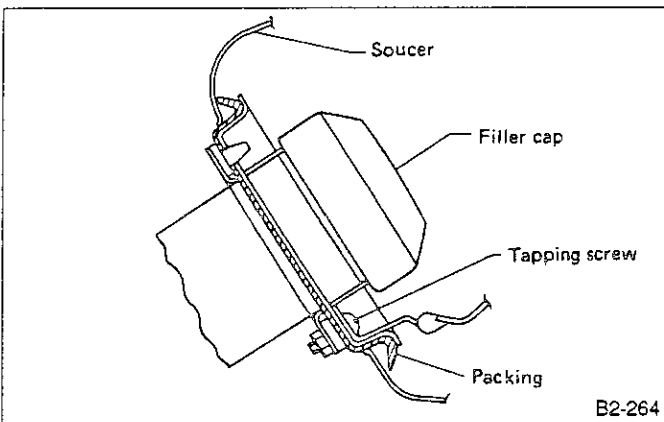


Fig. 30

3) If edges of rubber packing are folded toward the inside, straighten it with a standard screwdriver.

4) Insert fuel filler hose approximately 25 to 30 mm (0.98 to 1.18 in) over the lower end of fuel filler pipe and tighten clamps. Do not allow clips to touch air vent hose, air breather hoses and rear suspension cross-member.

5) Insert air vent hose approximately 25 to 30 mm (0.98 to 1.18 in) into the lower end of air vent pipe and tighten with clips.

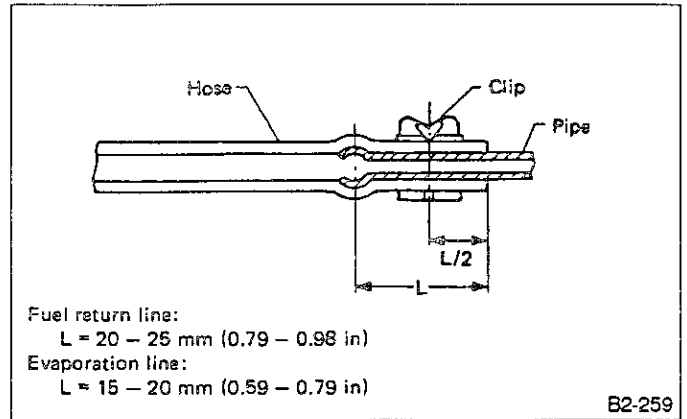


Fig. 31

6) Install protector together with fuel filler pipe. Check to be sure clamp for filler hose and clip for air vent hose do not touch body.

4. Fuel Filter

A: REMOVAL

1. MPFI AND SPFI MODELS

1) Release the fuel pressure.

Refer to Section 1. [W101]

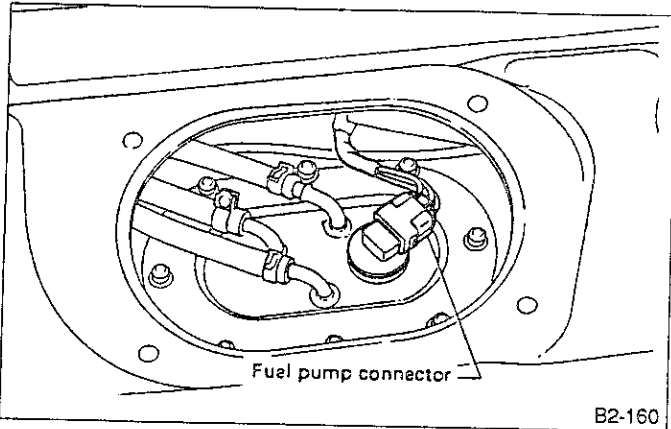


Fig. 32

2) Loosen the screw of the hose clamp and pull off the hose from the filter.

3) Remove the filter from the holder.

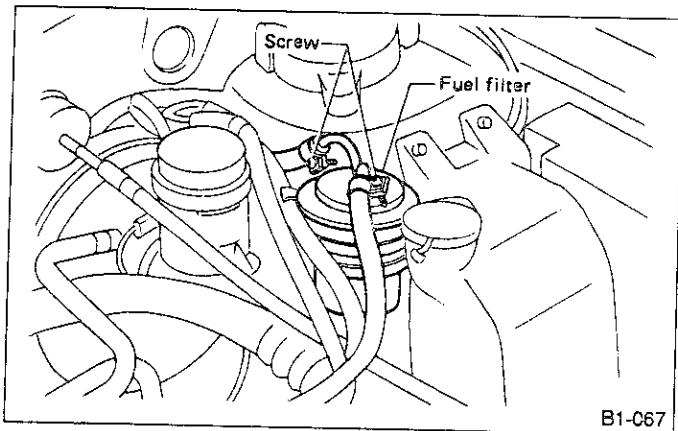


Fig. 33

2. CARBURETOR MODEL

1) Remove the fuel filter from the holder.

2) Unfasten the clip which connects the fuel hose to the fuel filter and disconnect the hose.

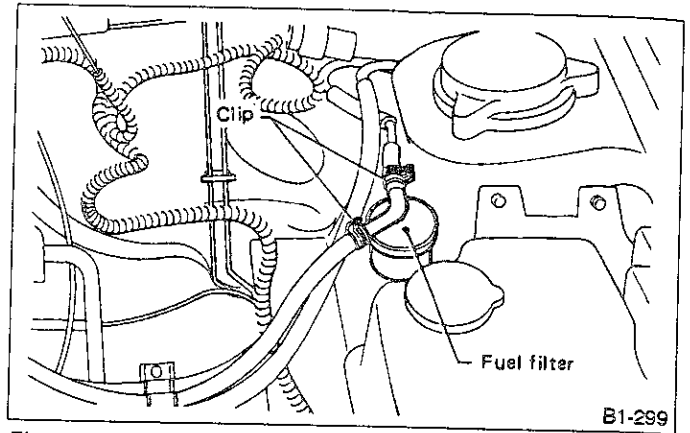


Fig. 34

B: INSPECTION

1) Check the inside of the filter for dirt and water sediment.

2) If the filter is clogged or cracked, or if the replacement interval has been reached, replace the filter.

3) If water is found in the filter, shake the filter with its inlet port facing down, to expel the water.

C: INSTALLATION

1. MPFI AND SPFI MODELS

1) Connect the hose as illustrated below:

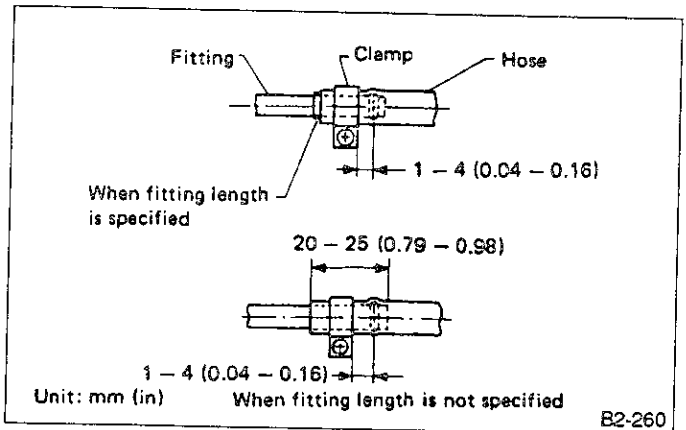


Fig. 35

2) Tighten the hose clamp screw to the specified torque.

Tightening torque:

1.0 - 1.5 N·m (0.1 - 0.15 kg-m, 0.7 - 1.1 ft-lb)

- 3) If the hose is damaged at the clamping portion, replace the hose with a new one.
- 4) If the hose clamp is too deformed, replace with a new one.
- 5) Fit the hose to the filter, then install the filter to the holder. Correct the hose position by removing any twist so that it will not interfere with the filter body or washer tank, before tightening the screw of the hose clamp.

2. CARBURETOR MODEL

- 1) Connect the hose as illustrated below:

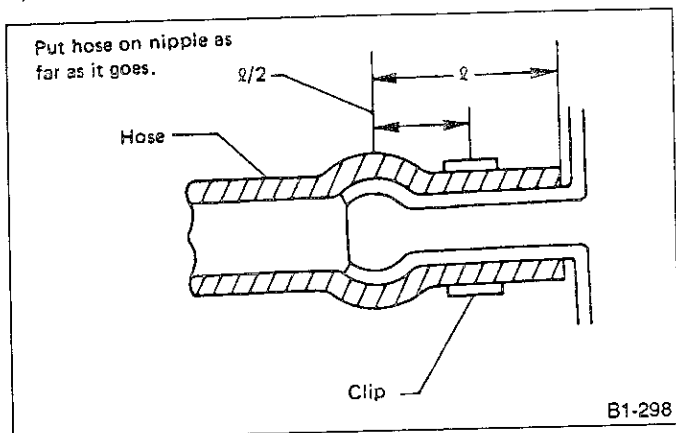


Fig. 36

- 2) Install the filter to the holder.

5. Fuel Pump

A: REMOVAL

1. MPFI AND SPFI MODELS

- 1) Release the fuel pressure.
- Refer to Section 1. [W101]
- 2) Keep the connector disconnected.
 - 3) Loosen the hose clamp, and disconnect the hose.

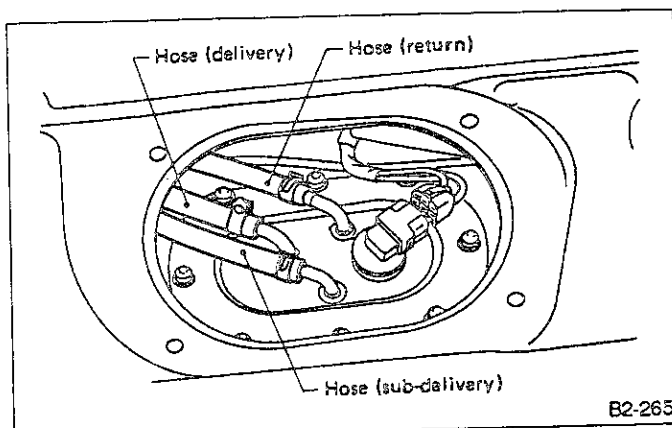


Fig. 37

- 4) Remove the eight nuts and detach fuel pump ASSY.

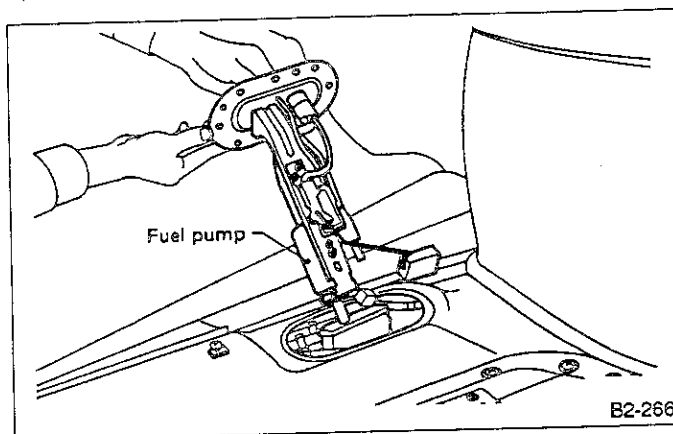


Fig. 38

2. CARBURETOR MODEL

- 1) Remove floor mat from luggage compartment.
- 2) Remove access hole lid.
- 3) Disconnect the wiring connector of the fuel pump.
- 4) Loosen the hose clamp, and disconnect the hose.
- 5) Remove the eight nuts and detach fuel pump ASSY.

B: INSPECTION

- 1) Connect the leads to the harness connector, and apply a 12-volt power supply to check whether the pump operates.
 - a. Keep the battery apart from the pump as far as possible.
 - b. Be sure to turn the 12 V supply ON and OFF on the battery side.
 - c. Do not run the pump for a long time under non-loaded condition.

C: INSTALLATION

Installation is in the reverse order of removal procedures. Observe the following:

- (1) Discard old gasket after removal. Replace with a new one.
- (2) Ensure sealing portion is free from fuel or foreign particles before installation. (Wipe unit mounting holes, packing, etc. with a cloth.)
- (3) Tighten nuts in numerical sequence shown below, to specified torque.

Tightening torque:

3 — 6 N·m (0.3 — 0.6 kg·m, 2.2 — 4.3 ft·lb)

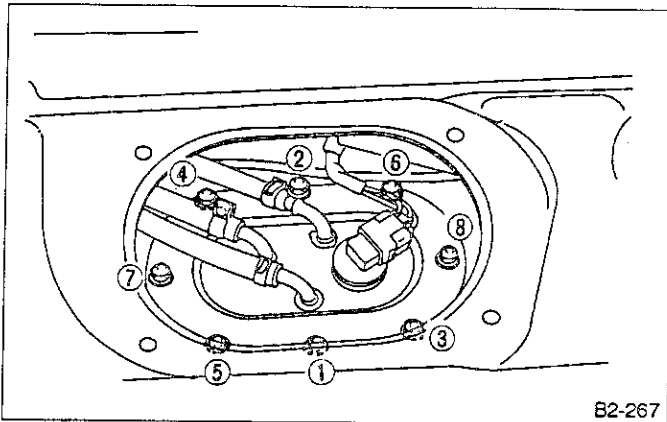


Fig. 39

- (4) Install O-ring, then access hole lid.

6. Fuel Meter Unit**A: REMOVAL**

- 1) Fuel meter unit is built into fuel pump ASSY. Before disconnecting hoses, relieve fuel pressure as outlined under "REMOVAL" for fuel pump (MPFI and SPFI models only).
- 2) Loosen hose clamp, and disconnect the hose.

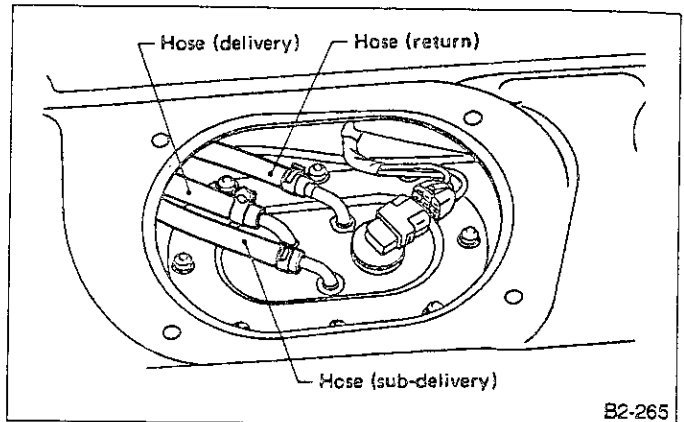


Fig. 40

- 3) Remove the eight nuts and detach fuel pump ASSY.

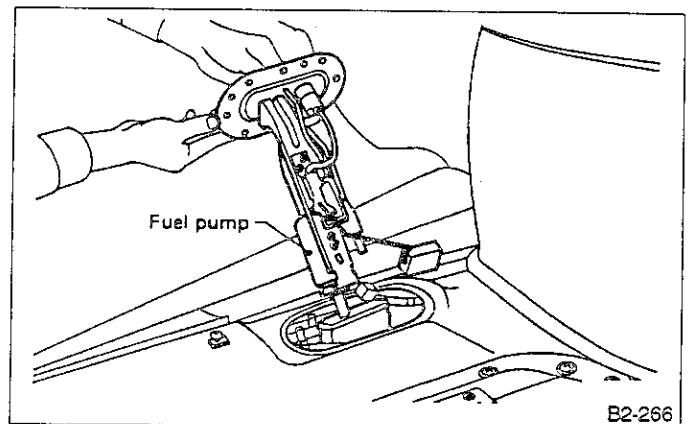


Fig. 41

B: INSTALLATION

Refer to "INSTALLATION" for fuel pump.

7. Fuel Meter Unit (4WD model only)

Two fuel meter units are utilized on 4WD models.

A: REMOVAL

- 1) Remove floor mat from luggage compartment.
- 2) Remove access hole lid.
- 3) Disconnect harness connector from fuel meter unit.

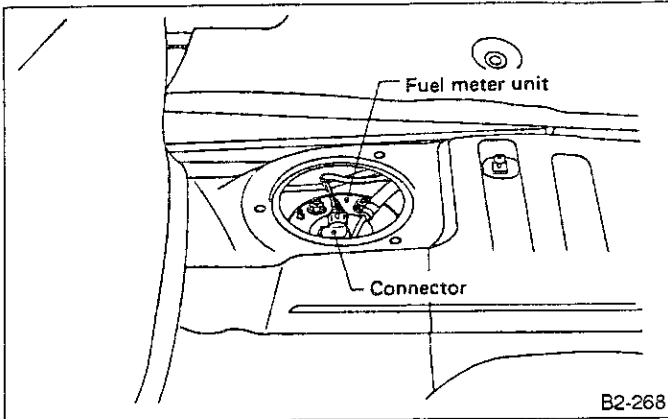


Fig. 42

- 4) Remove five nuts and detach fuel meter unit.

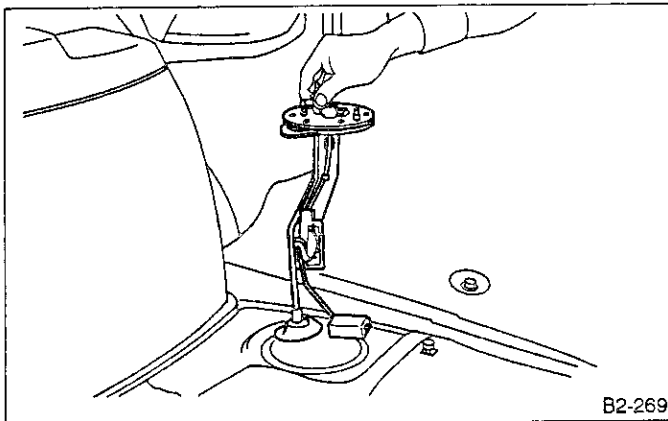


Fig. 43

B: INSTALLATION

Installation is in the reverse order of removal procedures. Observe the following:

- (1) Discard old packing (85125AA000) after removal. Replace with new.
- (2) Ensure sealing portion is free from fuel or foreign particles before installation. (Wipe unit mounting holes, packing, etc. clean with a cloth.)
- (3) Tighten nuts in numerical sequence shown below, to specified torque.

Tightening torque:

3 — 6 N·m (0.3 — 0.6 kg-m, 2.2 — 4.3 ft-lb)

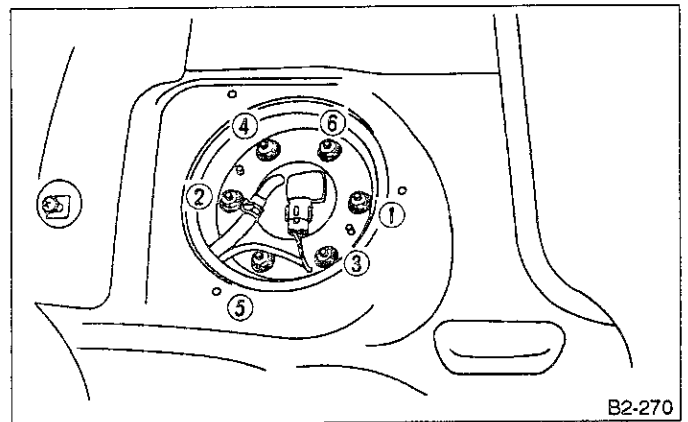


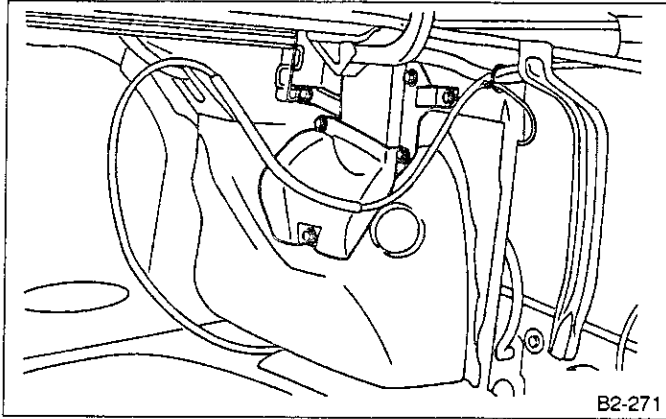
Fig. 44

- (4) Install O-ring, then access hole lid.

8. Fuel Separator (4WD model only)

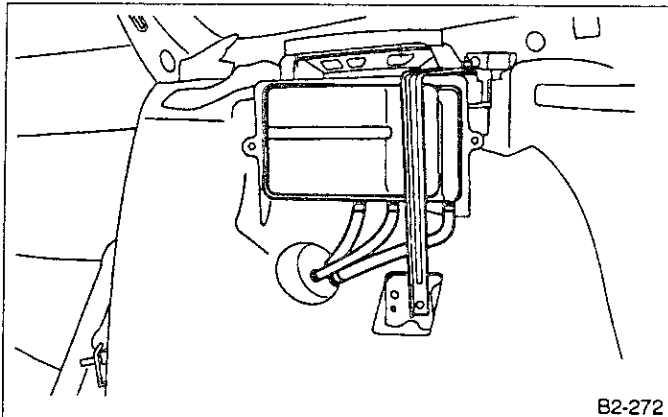
A: REMOVAL

- 1) Remove right trim from luggage compartment.
- 2) Remove hose protector. (Sedan only)
- 3) Remove bracket. Be sure not to scratch inner side of car body.



B2-271

Fig. 45 Sedan



B2-272

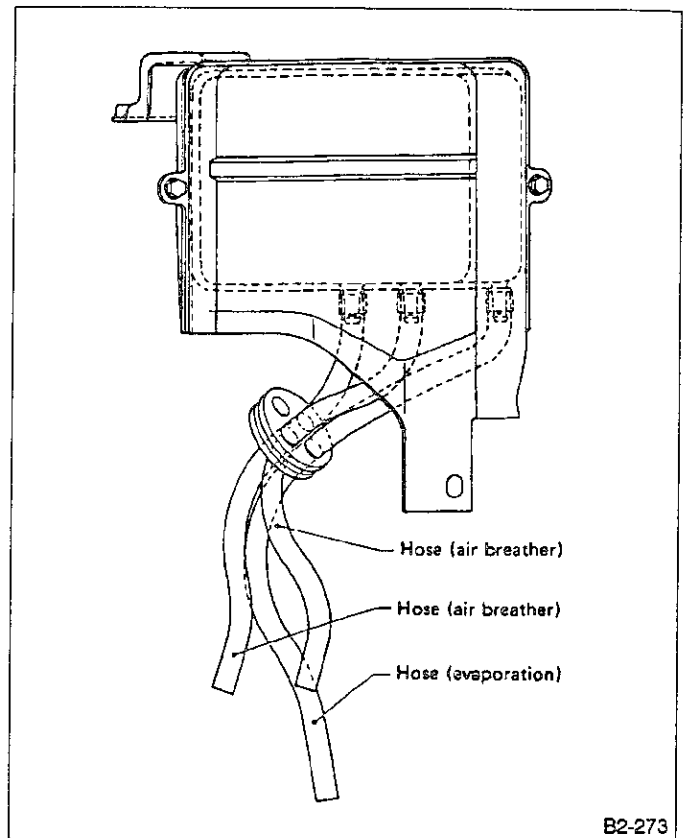
Fig. 46 Wagon

- 4) Disconnect evaporation hoses from separator.

B: INSTALLATION

Installation is in the reverse order of removal. Observe the following:

- a. Ensure proper connections.
- b. When connecting tubes, do not use soapy water as a lubricant.



Hose (air breather)

Hose (air breather)

Hose (evaporation)

B2-273

Fig. 47

9. Fuel Delivery, Return and Evaporation Lines

A: REMOVAL

1) Before disconnecting hoses, relieve fuel pressure as outlined under fuel pump "REMOVAL".

2) Remove inner trim, insulator, rear seat and fuel tank. Remove fuel delivery pipes and hoses, fuel return pipes and hoses, and evaporation pipes and hoses.

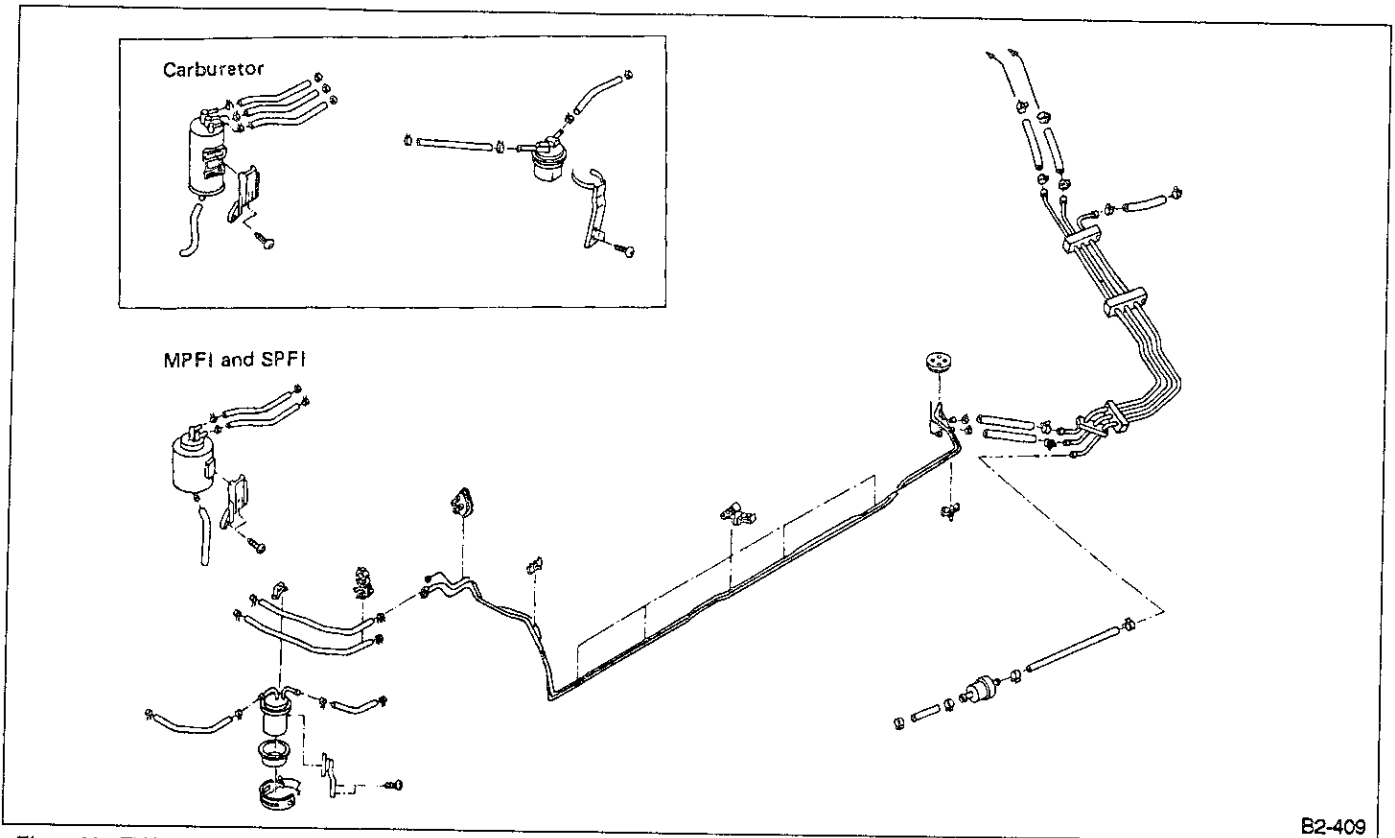
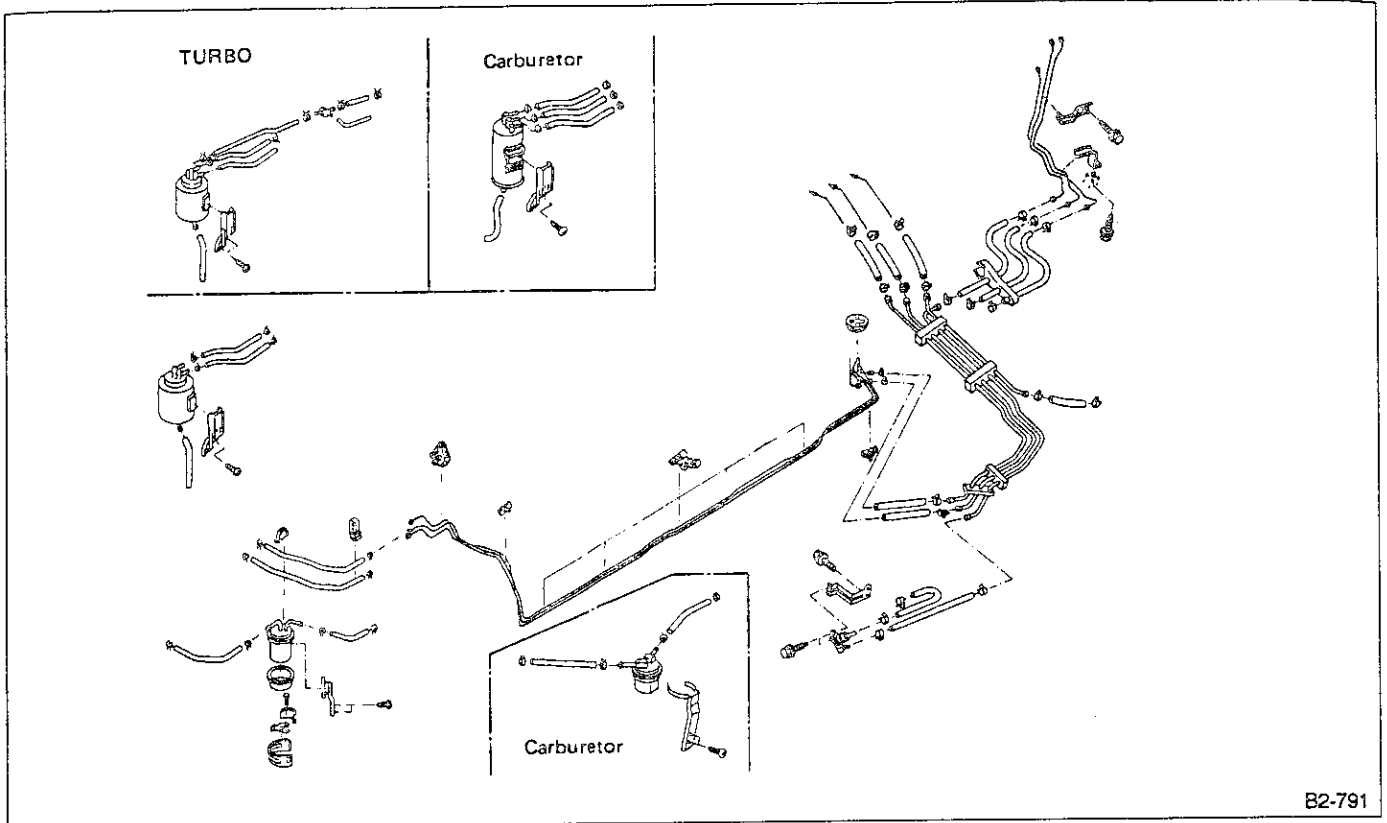


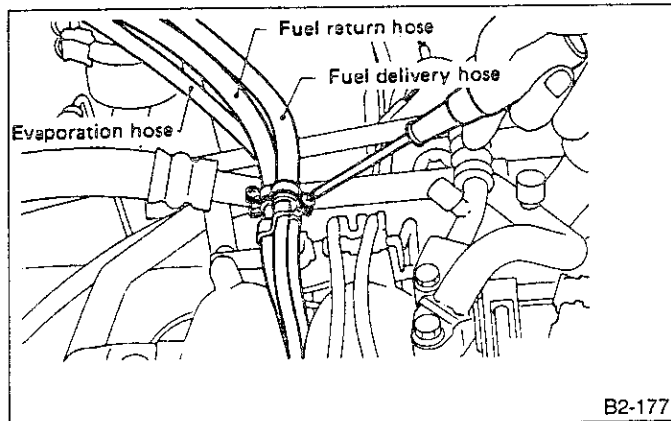
Fig. 48 FWD model



B2-791

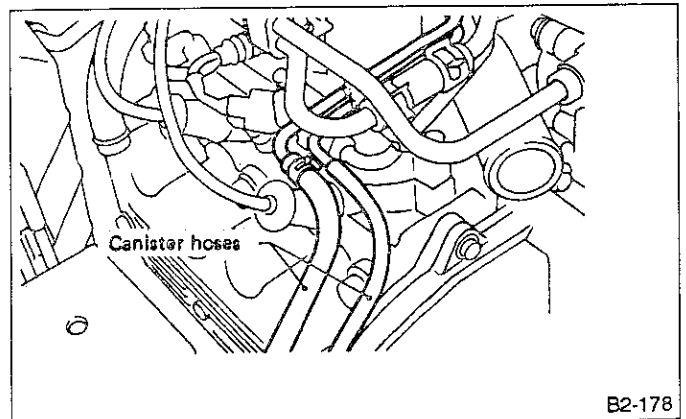
Fig. 49 4WD model

2) In engine compartment, detach fuel delivery hoses, return hoses, evaporation tubes and canister.



B2-177

Fig. 50



B2-178

Fig. 51 SPFI and MPFI models

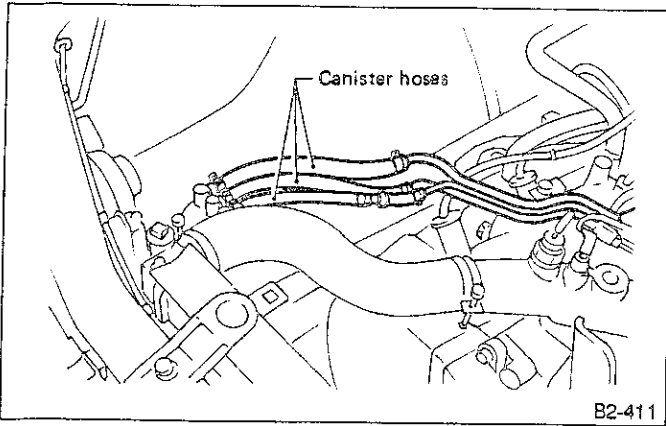


Fig. 52 Carburetor model

B: INSTALLATION

Install in the reverse order of removal.

- 1) Connect delivery hose to delivery pipe with an overlap of 20 to 25 mm (0.79 to 0.98 in).
- 2) Connect delivery hoses and fuel return hose to fuel tank until they reach the base of each pipe.
- 3) Insert evaporation tube into evaporation pipe by approx. 15 mm (0.59 in) and position a clip with approx. 8 mm (0.31 in) from hose end.
- 4) Be sure to inspect hoses and their connections for any leakage of fuel.

10. Two-way Valve

A: REMOVAL

Remove hoses from two-way valve.

B: INSPECTION

Connect 50 to 100 mm length of hose to two-way valve connections (tank and canister sides).
Blow air through pipe to check valve operation.

When air is gently blown through pipe (tank side)	Air does not flow smoothly.
When air is normally blown through pipe (tank side)	Air flows easily.
When air is gently blown through pipe (canister side)	Air flows.

Be careful not to inhale vapor when placing hose to mouth.

C: INSTALLATION

Install two-way valve with "TO ENGINE" mark facing the engine (canister hose).

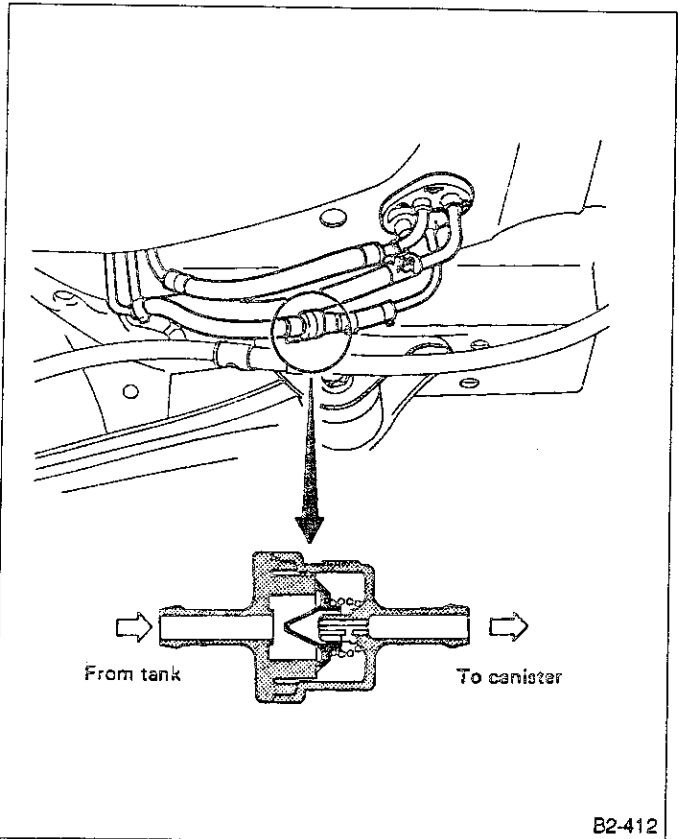


Fig. 53

T TROUBLESHOOTING

Trouble and possible cause		Corrective action
1. Insufficient fuel supply to the injector (or carburetor)		
1)	Fuel pump will not operate.	
	o Defective terminal contact.	Inspect connections, especially ground, and tighten securely.
	o Trouble in electromagnetic or electronic circuit parts.	Replace fuel pump.
2)	Lowering of fuel pump function.	Replace fuel pump.
3)	Clogged dust or water in the fuel filter.	Replace fuel filter, clean or replace fuel tank.
4)	Clogged or bent fuel pipe or hose.	Clean, correct or replace fuel pipe or hose.
5)	Air is mixed in the fuel system.	Inspect or retighten each connection part.
6)	Clogged or bent air breather tube or pipe.	Clean, correct or replace air breather tube or pipe.
7)	Damaged diaphragm of pressure regulator.	Replace.
8)	Fuel damper will not operate.	Replace.
2. Leakage or blow out fuel		
1)	Loosened joints of the fuel pipe.	Retightening.
2)	Cracked fuel pipe, hose and fuel tank.	Replace.
3)	Defective welding part on the fuel tank.	Replace.
4)	Defective drain packing of the fuel tank.	Replace.
5)	Clogged or bent air breather tube or air vent tube.	Clean, correct or replace air breather tube or air vent tube.
3. Gasoline is smelling inside of compartment		
1)	Loosened joints at air breather tube, air bent tube and fuel filler pipe.	Retightening.
2)	Defective packing air tightness on the fuel saucer.	Correct or replace packing.
3)	Cracked fuel separator.	Replace separator.
4. Defective fuel meter indicator		
1)	Defective operation of fuel meter unit.	Replace.
2)	Defective operation of fuel meter.	Replace.
5. Noise		
1)	Large operation noise or vibration of fuel pump.	Replace.

a. When the vehicle is left unattended for an extended period of time:

1) Water may accumulate in the fuel tank. To prevent water condensation, top off the fuel tank or drain the fuel completely.

2) Drain water condensation from the fuel filter.

b. Refilling the fuel tank.

1) Refill the fuel tank while there is still some fuel left in the tank.

c. Protecting the fuel system against freezing and water condensation.

1) Cold areas

In snow-covered areas, mountainous areas, skiing areas, etc. where ambient temperatures drop below 0°C (32°F) throughout the winter season, use an anti-freeze solution in the cooling system.

Refueling will also complement the effect of anti-freeze solution each time the fuel level drops to about one-half.

After the winter season, drain water which may have accumulated in the fuel filter and fuel tank in the manner same as that described under the Moderate Areas.

2) Moderate areas

When water condensation is noticed in the fuel filter, drain water from both the fuel filter and fuel tank or use a water removing agent (or anti-freeze solution) in the fuel tank.

• Observe the instructions, notes, etc., indicated on the label affixed to the anti-freeze solution (water removing agent) container before use.

C COMPONENT PARTS

1. Exhaust System

1. NON-TURBO, EUROPE CATALYST MODEL (US'83LDV)

Tightening torque: N·m (kg·m, ft·lb)
 T1: 25 - 34 (2.5 - 3.5, 18 - 25)
 T2: 30 - 40 (3.1 - 4.1, 22 - 30)
 T3: 13 - 23 (1.3 - 2.3, 9 - 17)
 T4: 43 - 53 (4.4 - 5.4, 32 - 39)
 T5: 10 - 16 (1.0 - 1.6, 7 - 12)

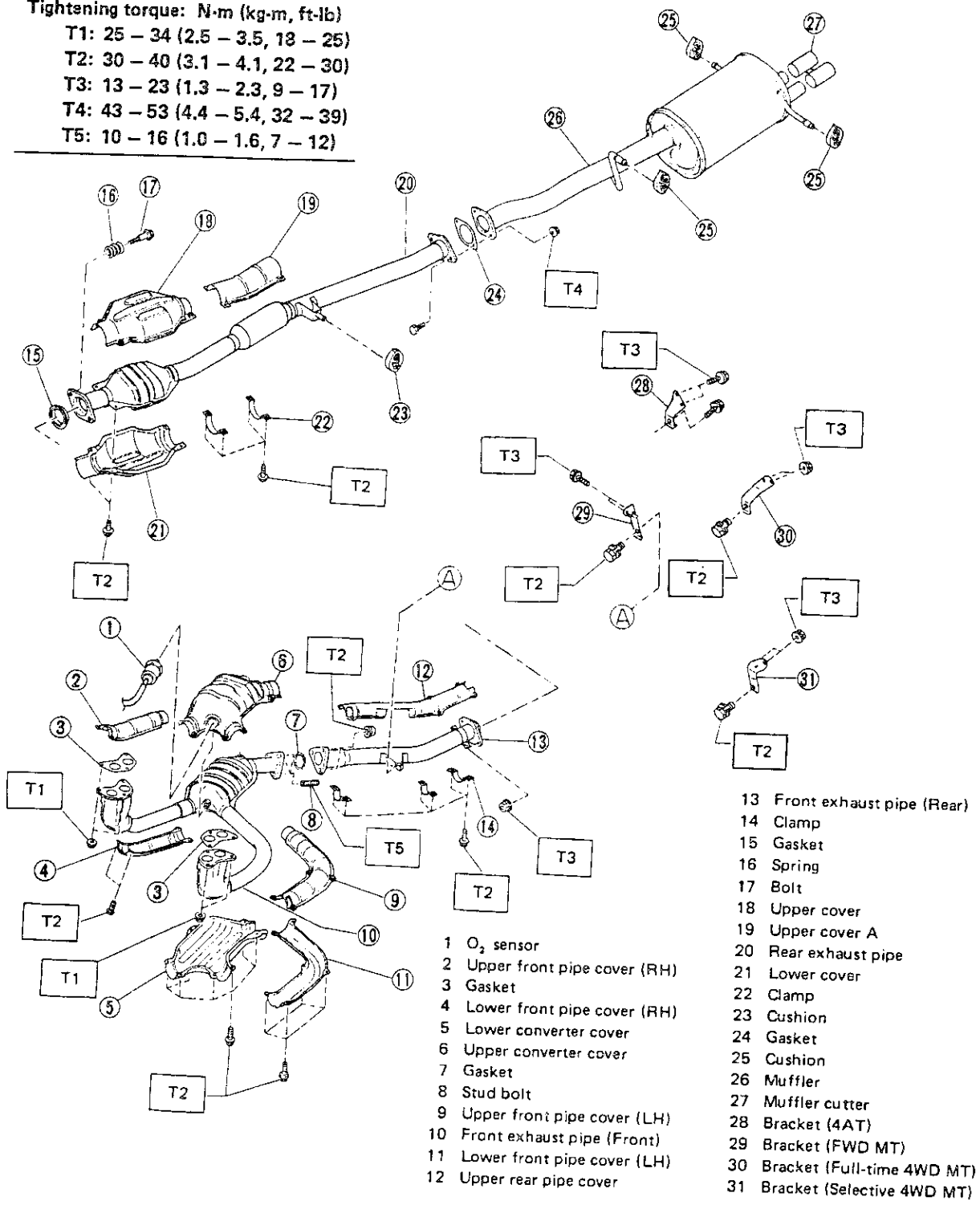


Fig. 1

2. NON-TURBO, EUROPE NON-CATALYST MODEL

Tightening torque: N·m (kg·m, ft·lb)
 T1: 25 - 34 (2.5 - 3.5, 18 - 25)
 T2: 30 - 40 (3.1 - 4.1, 22 - 30)
 T3: 13 - 23 (1.3 - 2.3, 9 - 17)
 T4: 43 - 53 (4.4 - 5.4, 32 - 39)

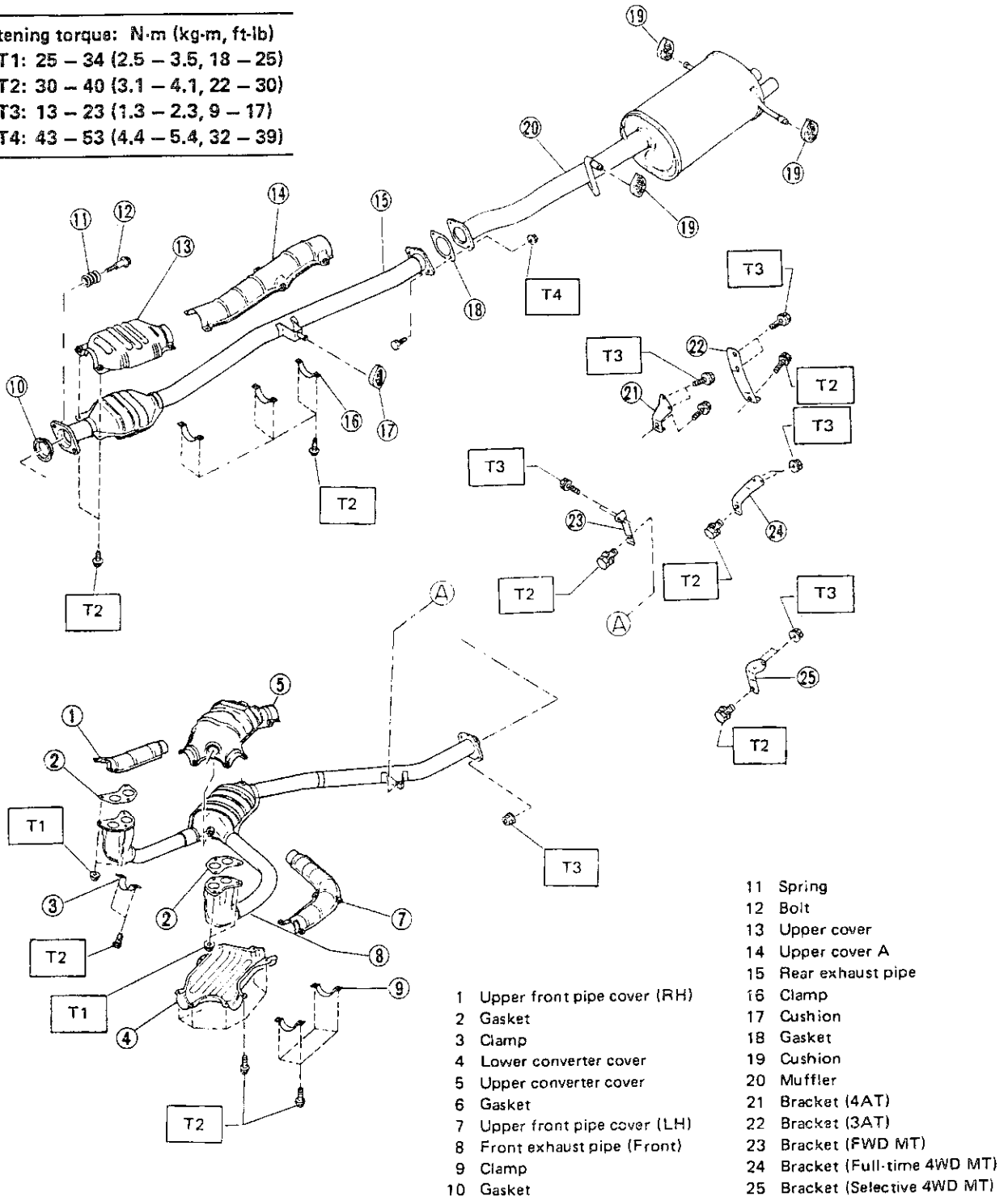
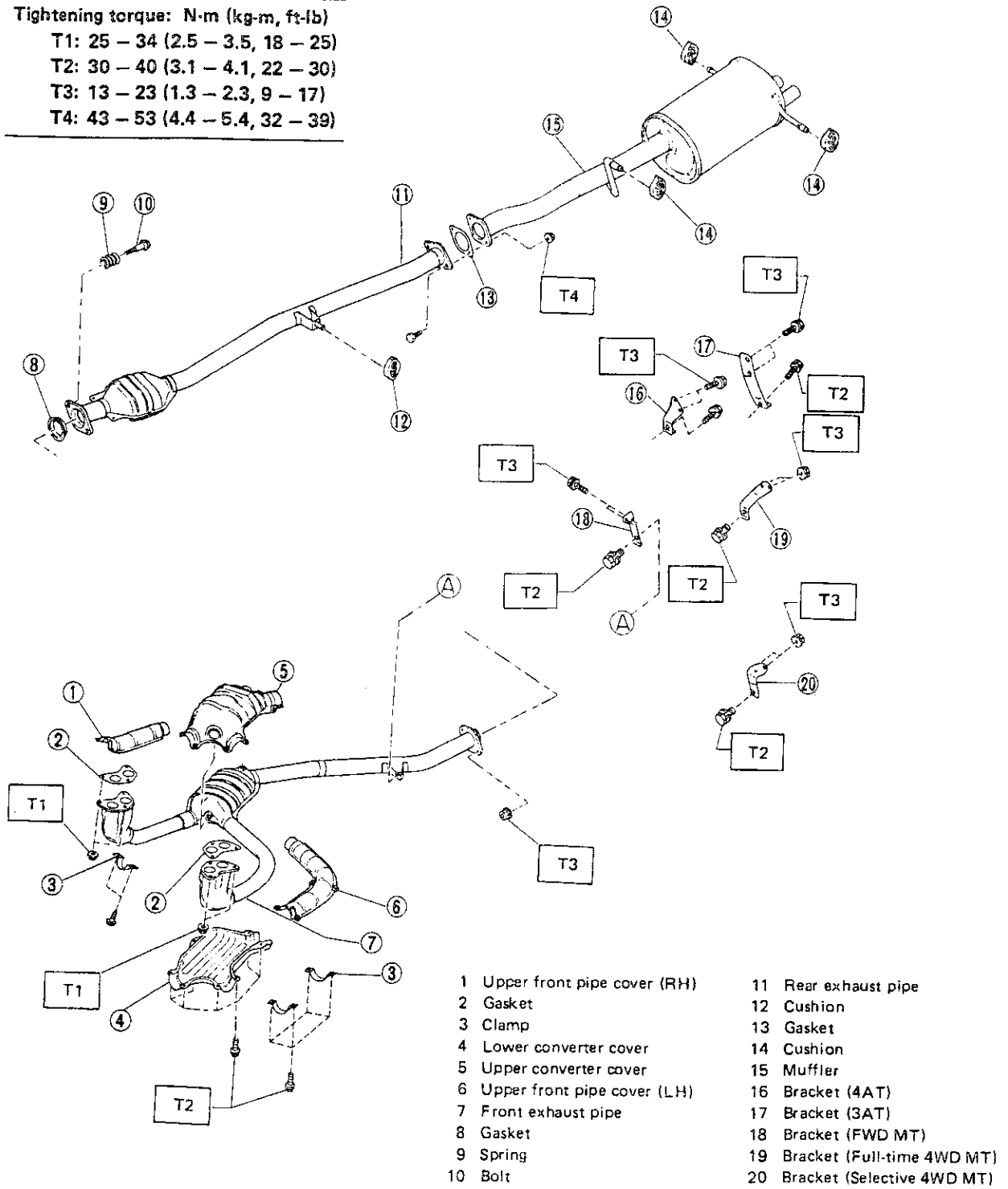


Fig. 2

B2-794

3. NON-TURBO, EXCEPT EUROPE MODEL

Tightening torque: N·m (kg·m, ft·lb)
 T1: 25 - 34 (2.5 - 3.5, 18 - 25)
 T2: 30 - 40 (3.1 - 4.1, 22 - 30)
 T3: 13 - 23 (1.3 - 2.3, 9 - 17)
 T4: 43 - 53 (4.4 - 5.4, 32 - 39)



- | | |
|-------------------------------|-------------------------------|
| 1 Upper front pipe cover (RH) | 11 Rear exhaust pipe |
| 2 Gasket | 12 Cushion |
| 3 Clamp | 13 Gasket |
| 4 Lower converter cover | 14 Cushion |
| 5 Upper converter cover | 15 Muffler |
| 6 Upper front pipe cover (LH) | 16 Bracket (4AT) |
| 7 Front exhaust pipe | 17 Bracket (3AT) |
| 8 Gasket | 18 Bracket (FWD MT) |
| 9 Spring | 19 Bracket (Full-time 4WD MT) |
| 10 Bolt | 20 Bracket (Selective 4WD MT) |

Fig. 3

B2-795

4. TURBO MODEL

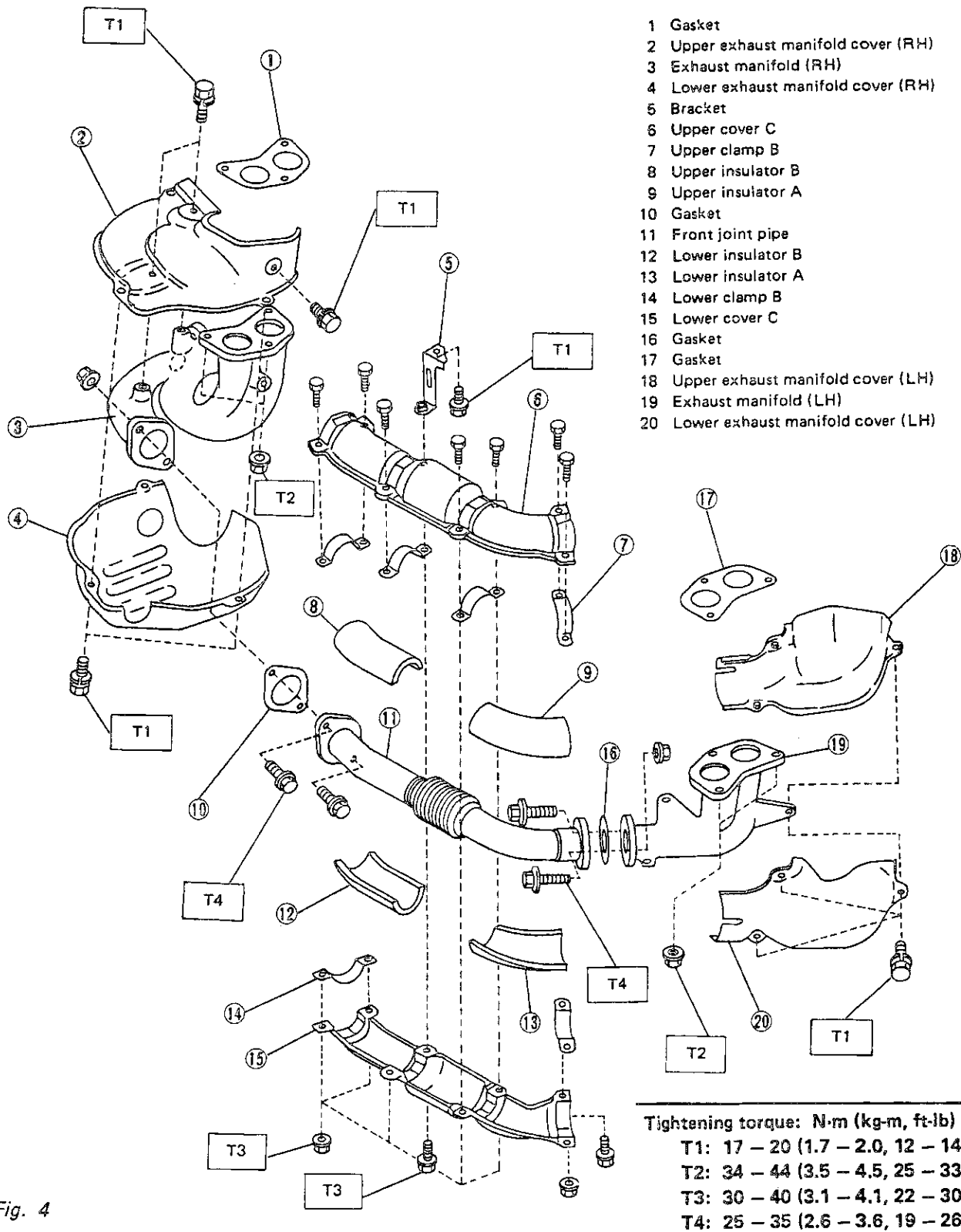
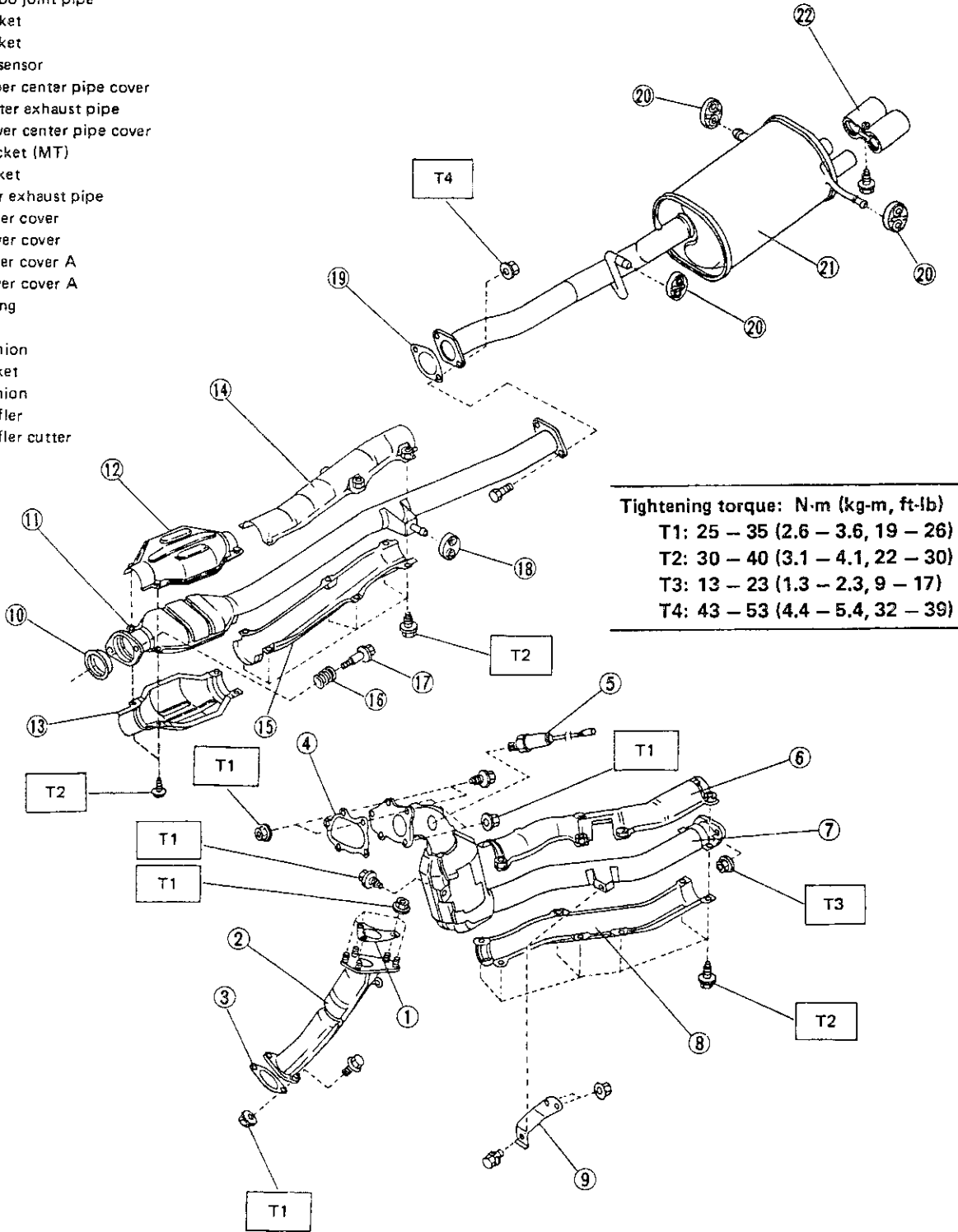


Fig. 4

B2-651

EXHAUST SYSTEM

- 1 Gasket
- 2 Turbo joint pipe
- 3 Gasket
- 4 Gasket
- 5 O₂ sensor
- 6 Upper center pipe cover
- 7 Center exhaust pipe
- 8 Lower center pipe cover
- 9 Bracket (MT)
- 10 Gasket
- 11 Rear exhaust pipe
- 12 Upper cover
- 13 Lower cover
- 14 Upper cover A
- 15 Lower cover A
- 16 Spring
- 17 Bolt
- 18 Cushion
- 19 Gasket
- 20 Cushion
- 21 Muffler
- 22 Muffler cutter



Tightening torque: N-m (kg-m, ft-lb)	
T1:	25 - 35 (2.6 - 3.6, 19 - 26)
T2:	30 - 40 (3.1 - 4.1, 22 - 30)
T3:	13 - 23 (1.3 - 2.3, 9 - 17)
T4:	43 - 53 (4.4 - 5.4, 32 - 39)

Fig. 5

B2-796

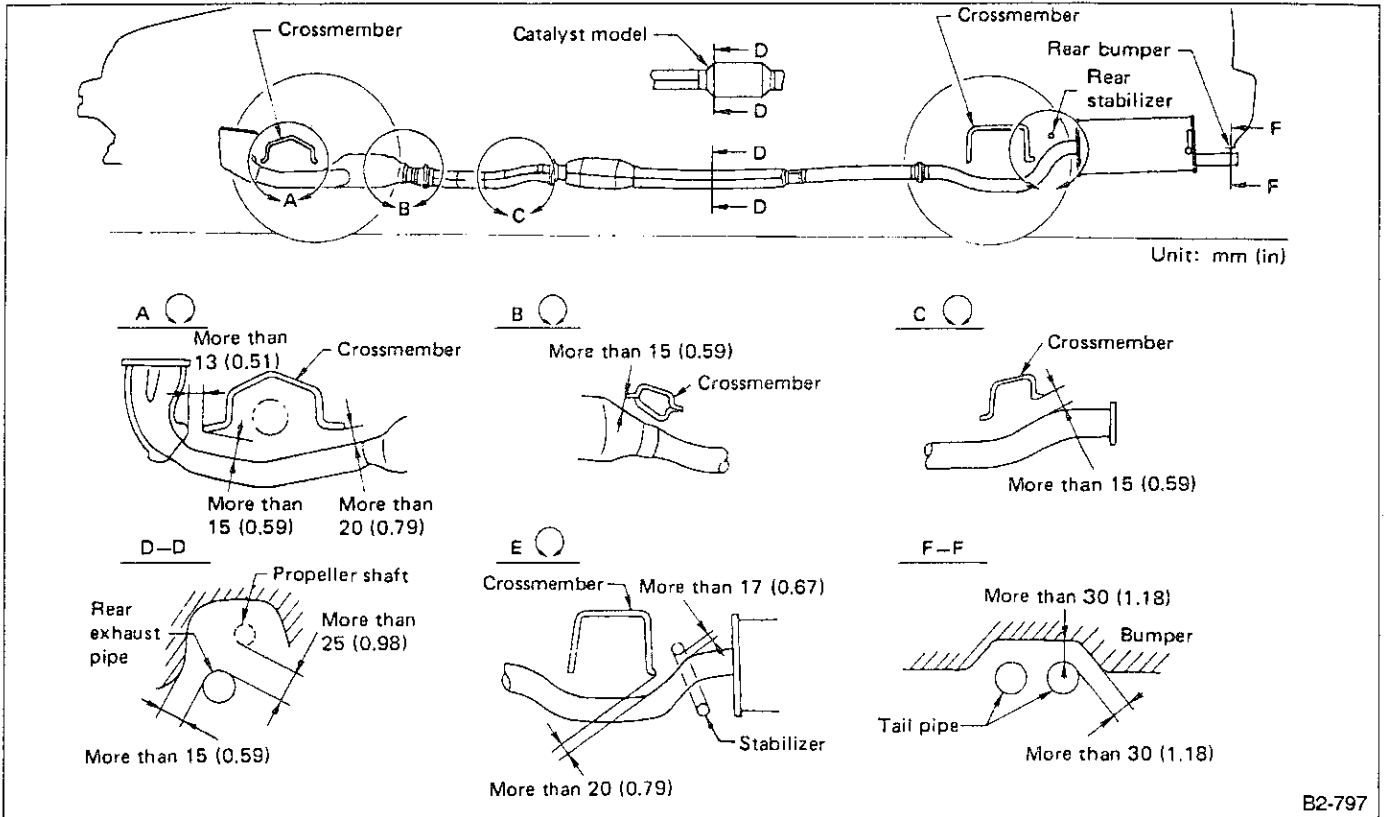
W SERVICE PROCEDURE

1. Exhaust System

A: ADJUSTMENT

1. NON-TURBO MODEL

- 1) Check to make sure clearances between parts and car body are larger than specified values.
- 2) If any clearance is not, loosen all connections.
- 3) Adjust where necessary to obtain proper clearance.
- 4) Tighten all connections to specified torque.



B2-797

Fig. 6

2. TURBO MODEL

1) Check to make sure clearances between parts and car body are larger than specified values.

2) If any clearance is not, loosen all connections.

3) Adjust where necessary to obtain proper clearance.

4) Tighten all connections to specified torque.

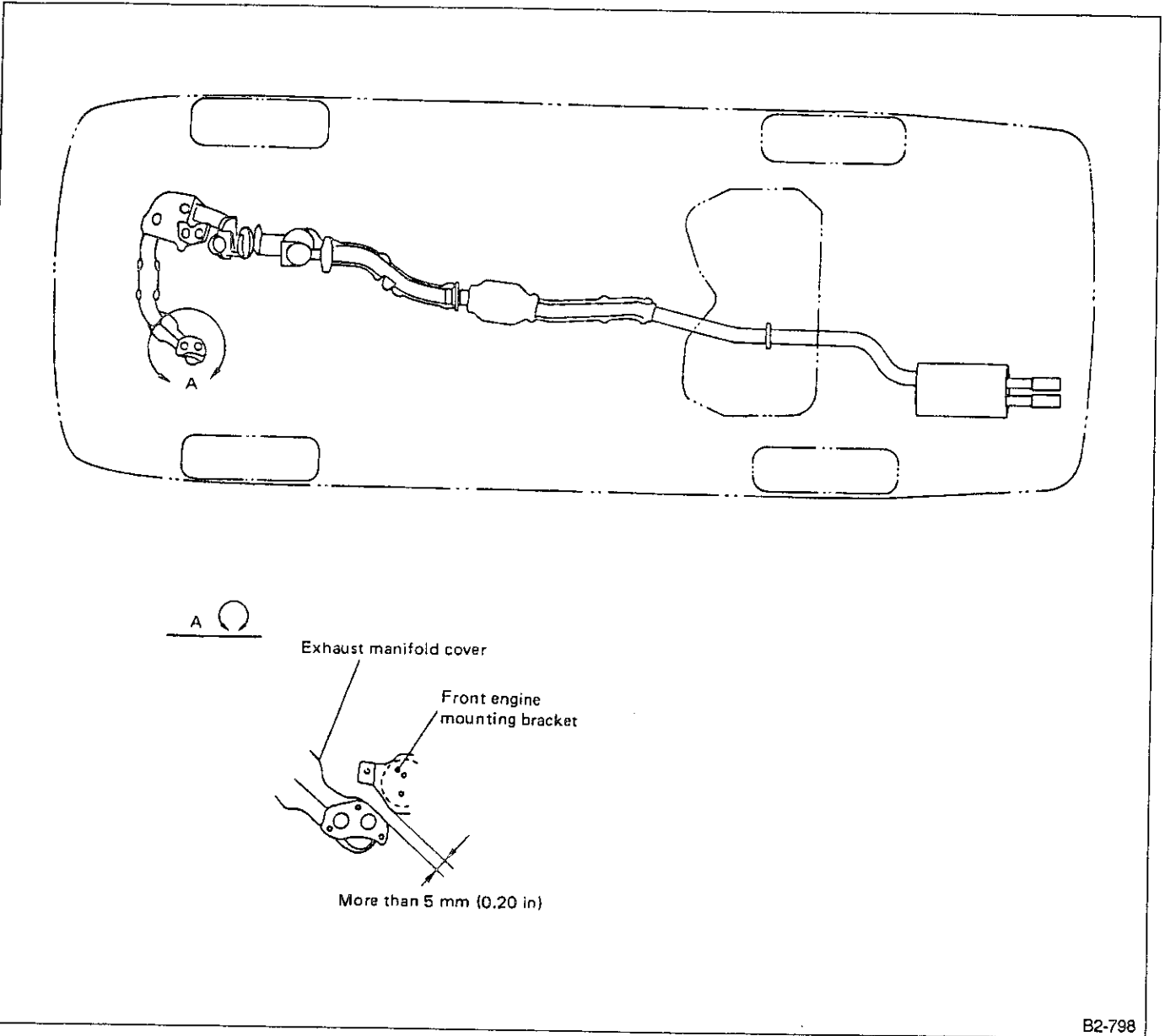
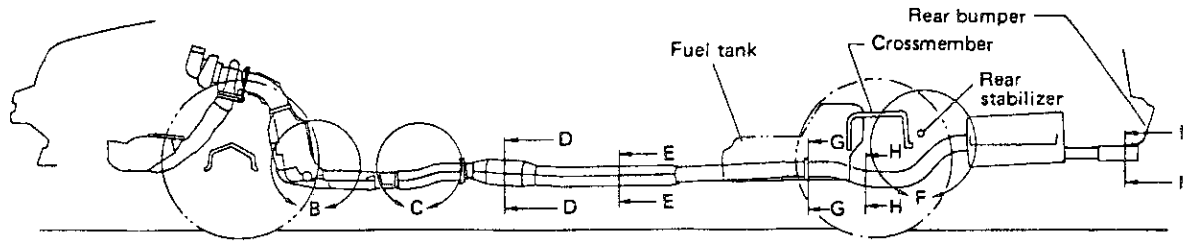


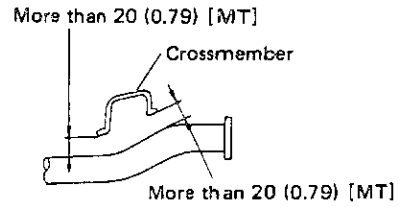
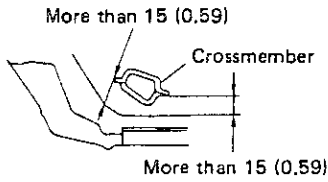
Fig. 7

B2-798



B-B

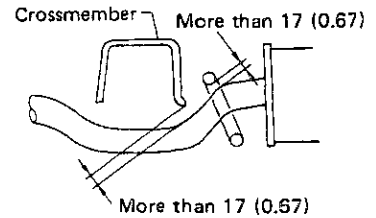
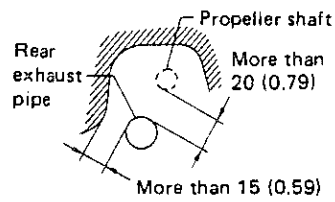
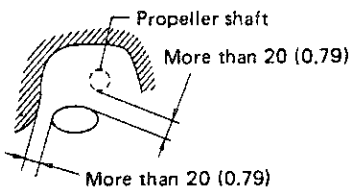
C-C



D-D

E-E

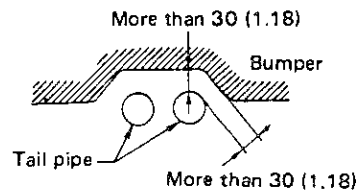
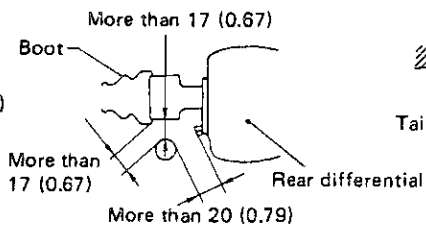
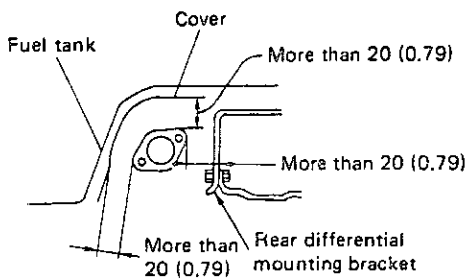
F-F



G-G

H-H

I-I



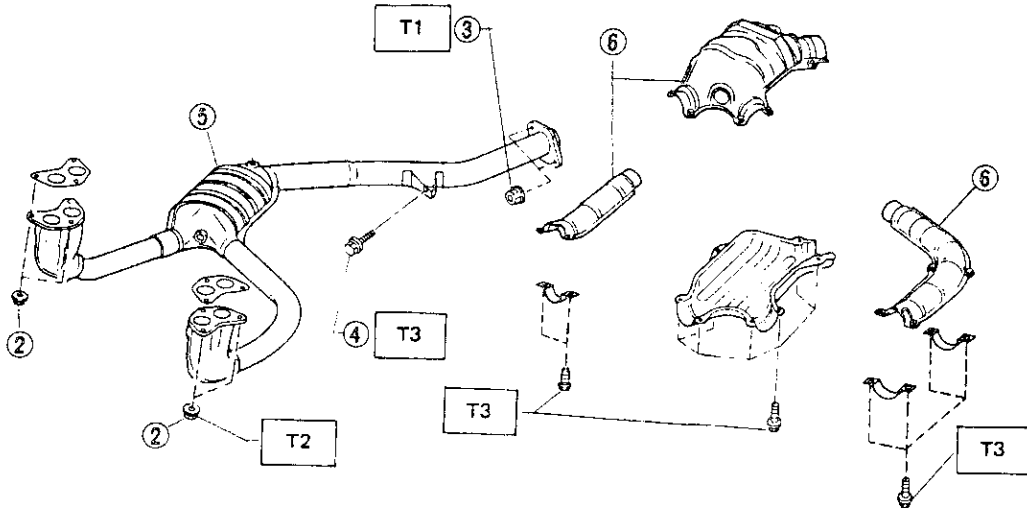
Unit: mm (in)

Fig. 8

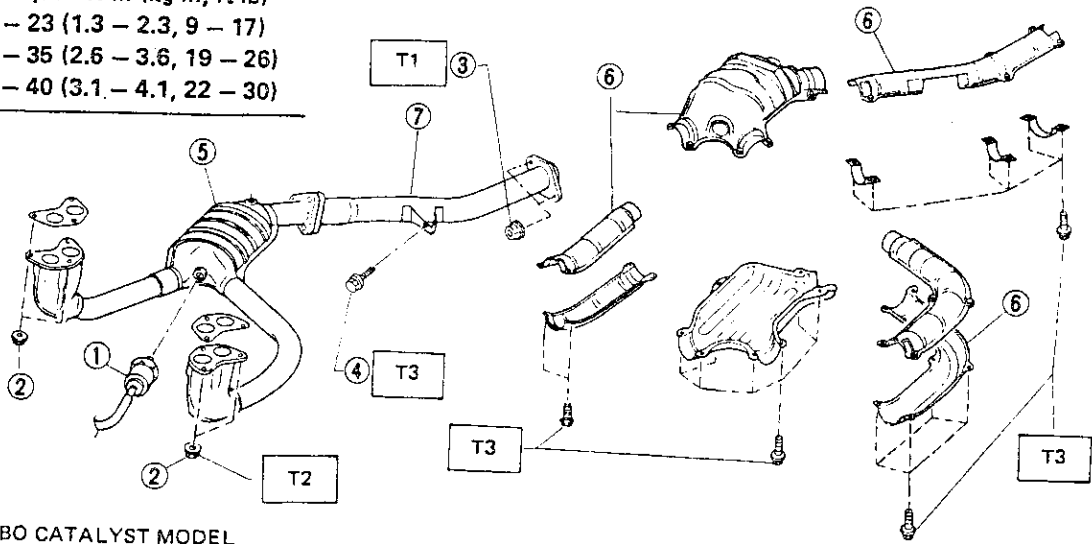
2. Front Exhaust Pipe

A: REMOVAL

1. NON-TURBO MODEL



Tightening torque: N·m (kg·m, ft·lb)
 T1: 13 - 23 (1.3 - 2.3, 9 - 17)
 T2: 25 - 35 (2.6 - 3.6, 19 - 26)
 T3: 30 - 40 (3.1 - 4.1, 22 - 30)



NON-TURBO CATALYST MODEL

B2-800

Fig. 9

- 1) Disconnect O₂ sensor harness (equipped model only).
- 2) Loosen (Do not remove) nuts which hold front exhaust pipe to exhaust port of engine.
- 3) Disconnect front and rear exhaust pipe.
- 4) Disconnect front exhaust pipe and bracket.
- 5) While holding front exhaust pipe with one hand, remove nuts which hold front exhaust pipe to exhaust port.
- 6) Remove heat sealed covers (only models equipped with the covers).
- 7) Disconnect front part and rear part of front exhaust pipe (only models where the parts can be separated).

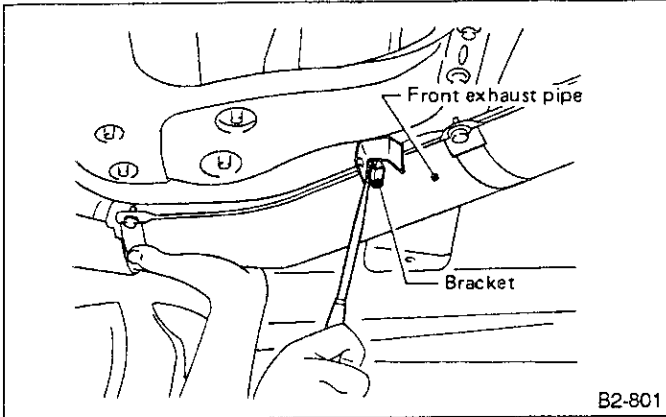
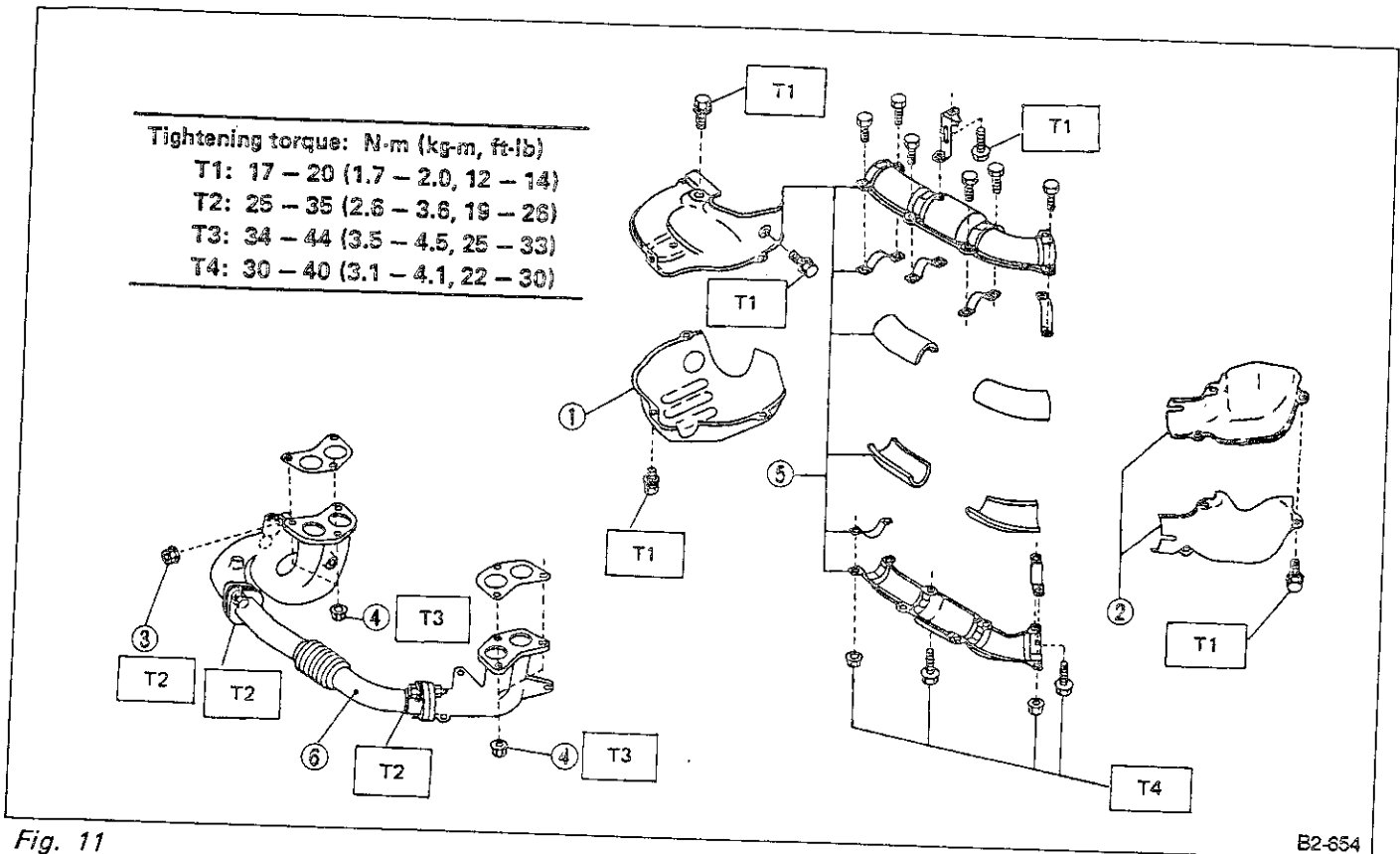


Fig. 10

2. TURBO MODEL



- 1) Remove lower exhaust manifold cover (RH).
- 2) Remove lower and upper exhaust manifold cover (LH).
- 3) Remove bolts and nuts which hold front exhaust pipe ASSY to turbo joint pipe.
- 4) While holding front exhaust pipe ASSY with one hand, remove nuts which hold front exhaust pipe ASSY to exhaust port. Front exhaust pipe ASSY can then be disconnected.

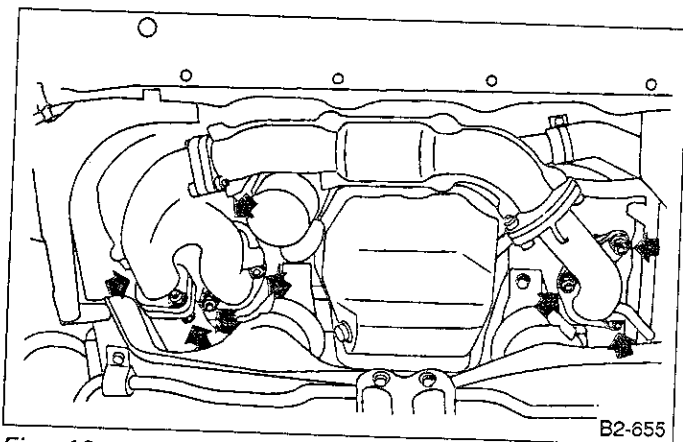
- 5) Remove exhaust manifold covers and insulators.
- 6) Disconnect front joint pipe and exhaust manifolds (LH and RH).

B: INSTALLATION

Assembly and installation is in the reverse order of removal procedures.

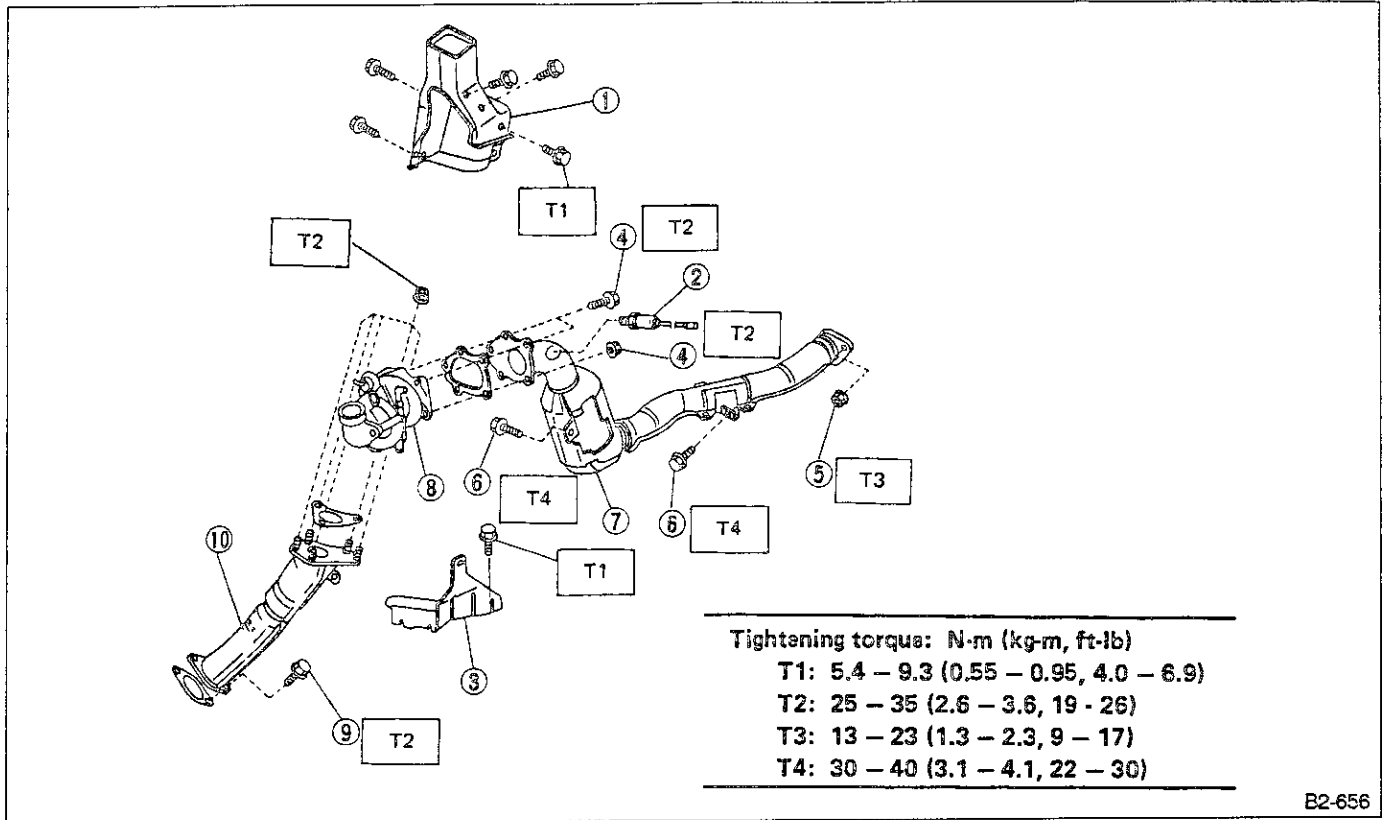
Observe the following.

- 1) Be sure to install a new gasket.
- 2) Use only nuts specified by the manufacturer.
- 3) Do not remove gasket placed between front and rear exhaust pipes. When front exhaust pipe needs to be replaced, gasket must also be replaced. (Non-TURBO model)



3. Center Exhaust Pipe and Turbo Joint Pipe (TURBO model only)

A: REMOVAL



B2-656

Fig. 13

- 1) Remove turbocharger cooling duct.
- 2) Disconnect O₂ sensor harness.
- 3) Remove turbocharger lower cover.
- 4) Disconnect center exhaust pipe and turbocharger.
- 5) Disconnect center and rear exhaust pipe.
- 6) Disconnect center exhaust pipe and bracket.
- 7) Remove center exhaust pipe.
- 8) Remove turbocharger.
- 9) Remove front exhaust pipe. (Ref. to 2. Front Exhaust pipe. (TURBO model) [W2A2])
- 10) Remove turbo joint pipe.

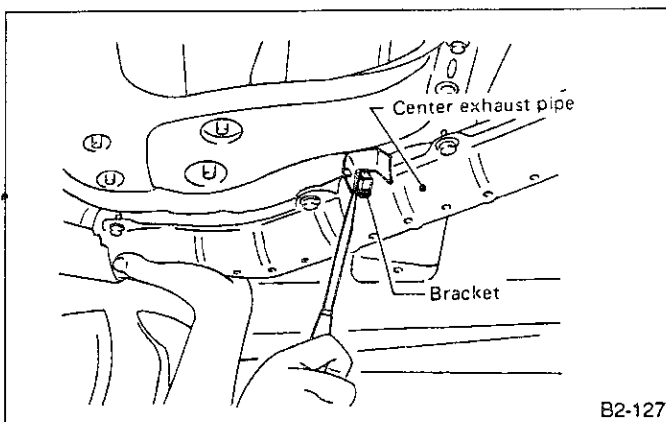


Fig. 14

B: INSTALLATION

Installation is in the reverse order of removal procedures.

Observe the following.

- 1) Be sure to install a new gasket at exhaust port.
- 2) Use only nuts specified by the manufacturer.
- 3) Do not remove gasket placed between center and rear exhaust pipes. When center exhaust pipe needs to be replaced, gasket must also be replaced.

4. Rear Exhaust Pipe

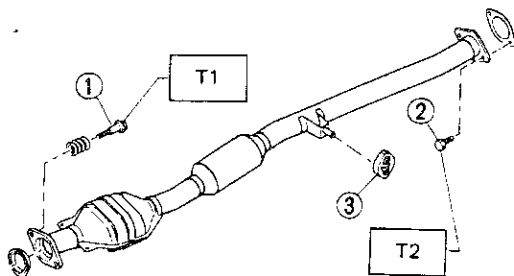
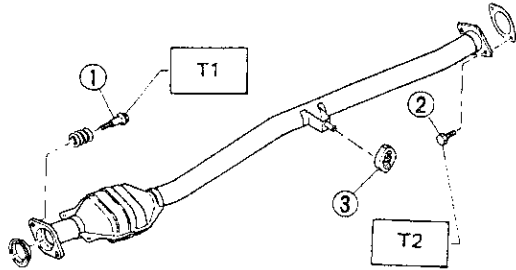
A: REMOVAL

Tightening torque: N·m (kg·m, ft·lb)

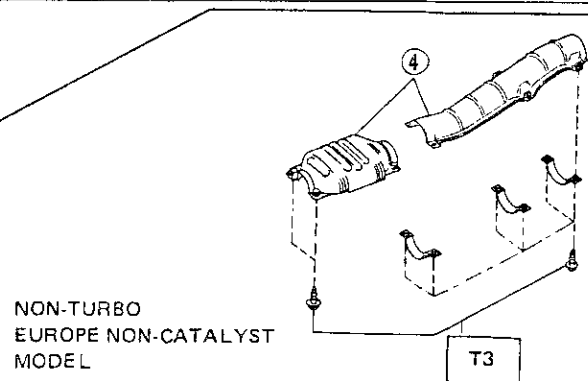
T1: 13 – 23 (1.3 – 2.3, 9 – 17)

T2: 43 – 53 (4.4 – 5.4, 32 – 39)

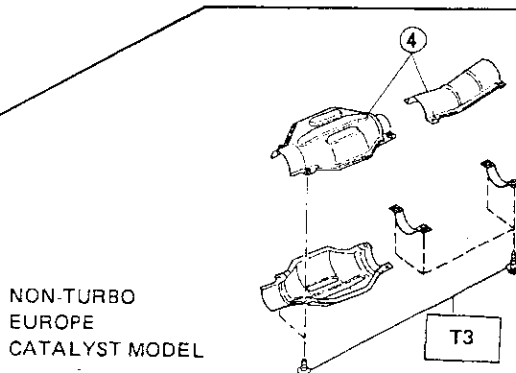
T3: 30 – 40 (3.1 – 4.1, 22 – 30)



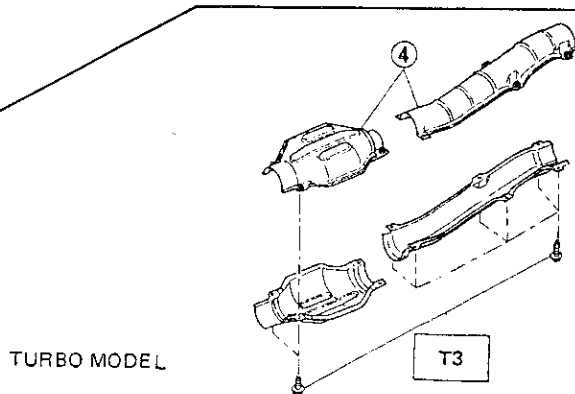
NON-TURBO EUROPE CATALYST MODEL



NON-TURBO
EUROPE NON-CATALYST
MODEL



NON-TURBO
EUROPE
CATALYST MODEL



TURBO MODEL

B2-802

Fig. 15

- 1) Disconnect rear exhaust pipe from front exhaust pipe.
- 2) Disconnect rear exhaust pipe from muffler ASSY. To prevent damage to bumper or rear skirt by muffler, wrap a cloth around tail pipe.
- 3) Remove rear exhaust pipe from rubber cushion. To facilitate its removal, apply a coat of SUBARU CRC5-56 (004301003) to it in advance.
- 4) Remove heat sealed covers (equipped model only).

B: INSTALLATION

- 1) Temporarily connect rear exhaust pipe and muffler ASSY.
- 2) Temporarily connect rear exhaust pipe and front exhaust pipe.
- 3) Insert exhaust pipe bracket into rubber cushion. To facilitate insertion, apply a coat of SUBARU CRC5-56 (004301003) to the mating area of rubber cushion in advance.
- 4) Adjust clearances between temporarily installed parts and tighten to specified torque.

Be sure to install bolts, springs, and self-locking nuts in the order indicated in the figure. Always install new self-locking nuts.

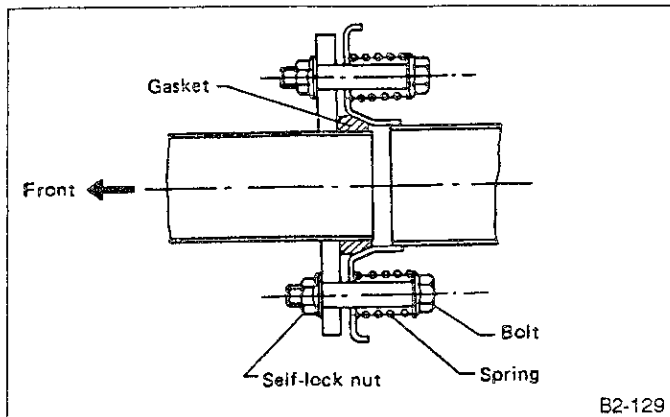


Fig. 16

5. Muffler ASSY

A: REMOVAL

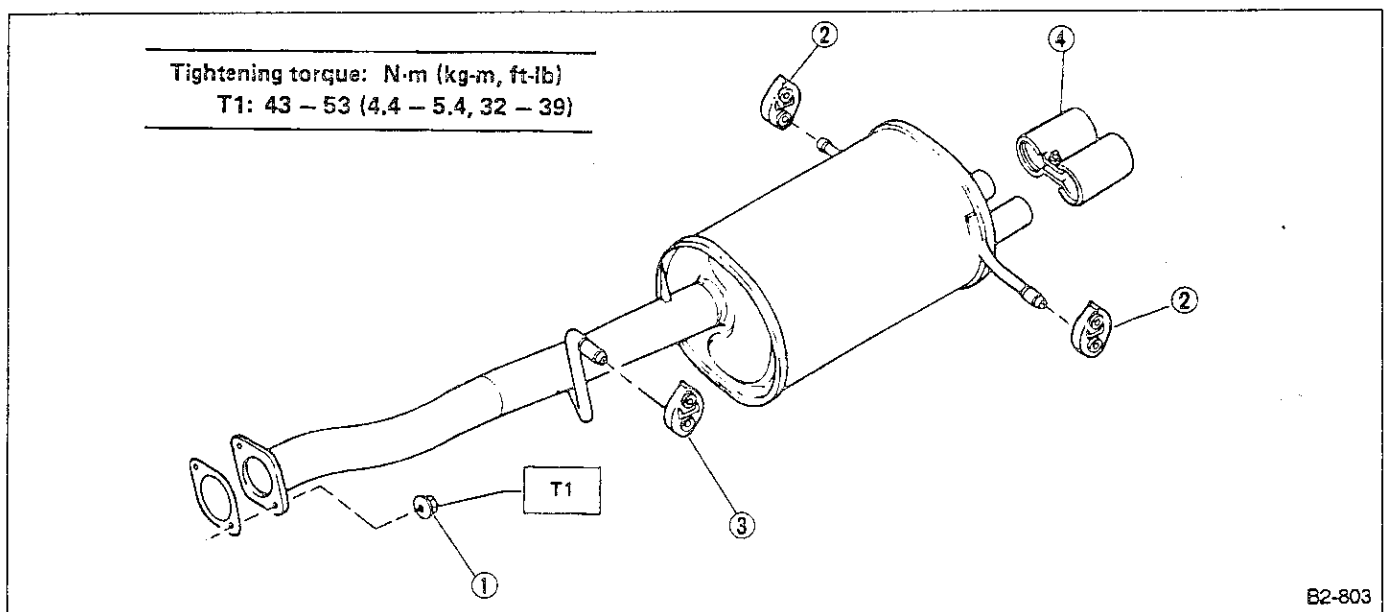


Fig. 17

1) To prevent damage to bumper or rear skirt near muffler, wrap a cloth around tail pipe. Remove bolts and self-locking nuts which hold rear exhaust pipe to muffler ASSY.

2) Remove left and right rubber cushions.

3) Remove front rubber cushion, and detach muffler ASSY.

4) Remove muffler cutter. (muffler cutter equipped model only)

B: INSTALLATION

Installation is in the reverse order of removal procedures.

Be sure to install new self-locking nuts and gaskets.

SUBARU®

1992

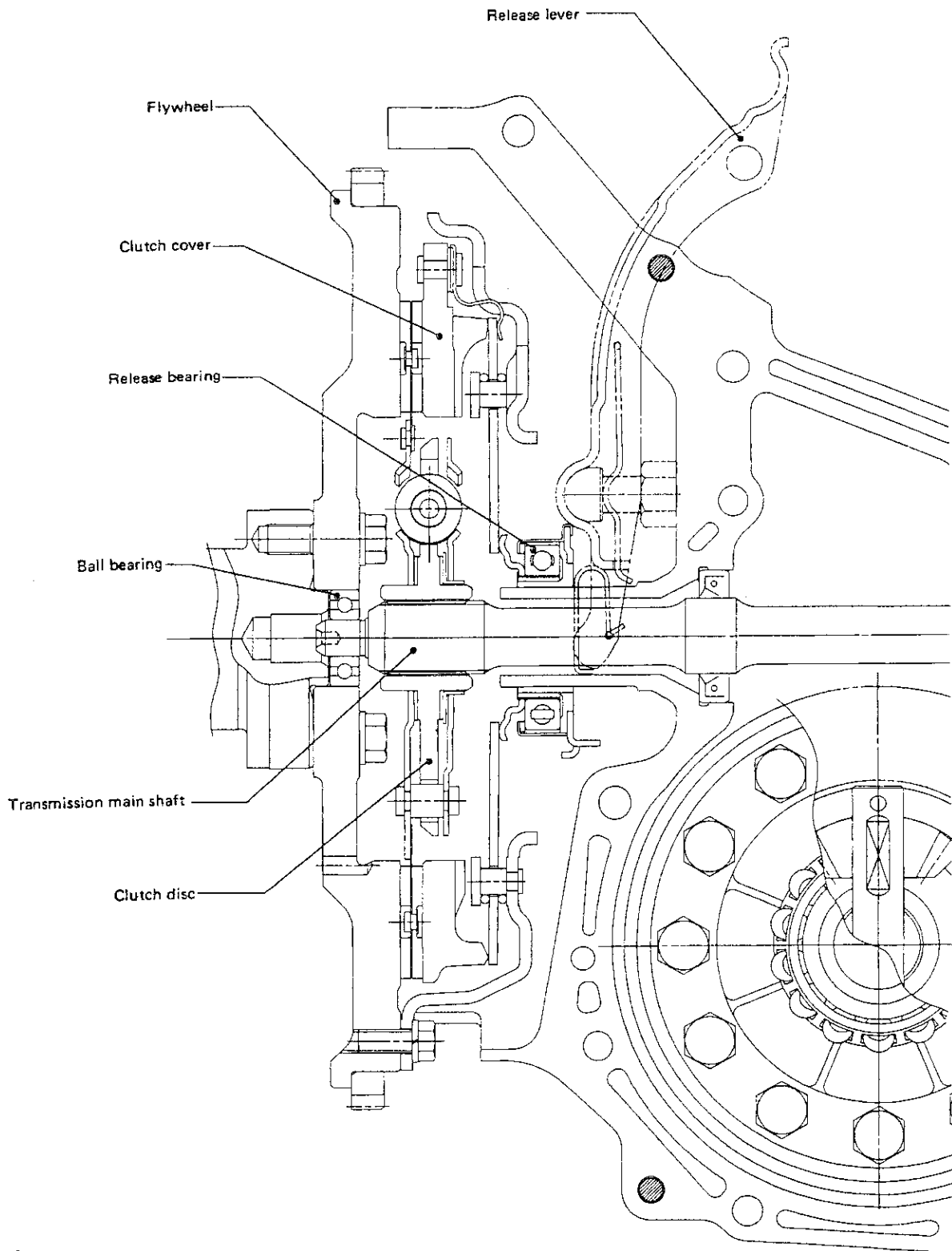
**SERVICE
MANUAL**

	Page
M MECHANISM AND FUNCTION	2
1. Cross Sectional View (Mechanical application type)	2
2. Cross Sectional View (Hydraulic application type)	3
S SPECIFICATIONS AND SERVICE DATA	4
C COMPONENT PARTS	5
1. Clutch System (Mechanical application type)	5
2. Clutch System (Hydraulic application type)	6
3. Master Cylinder and Reservoir Tank (Hydraulic application type)	7
W SERVICE PROCEDURE	8
1. General	8
2. Release Bearing and Lever	9
3. Clutch Disc and Cover	11
4. Operating Cylinder (Hydraulic application type only)	12
5. Master Cylinder and Reservoir Tank (Hydraulic application type only)	13
T TROUBLESHOOTING	14



M MECHANISM AND FUNCTION

1. Cross Sectional View (Mechanical application type)



B2-131

Fig. 1

2. Cross Sectional View (Hydraulic application type)

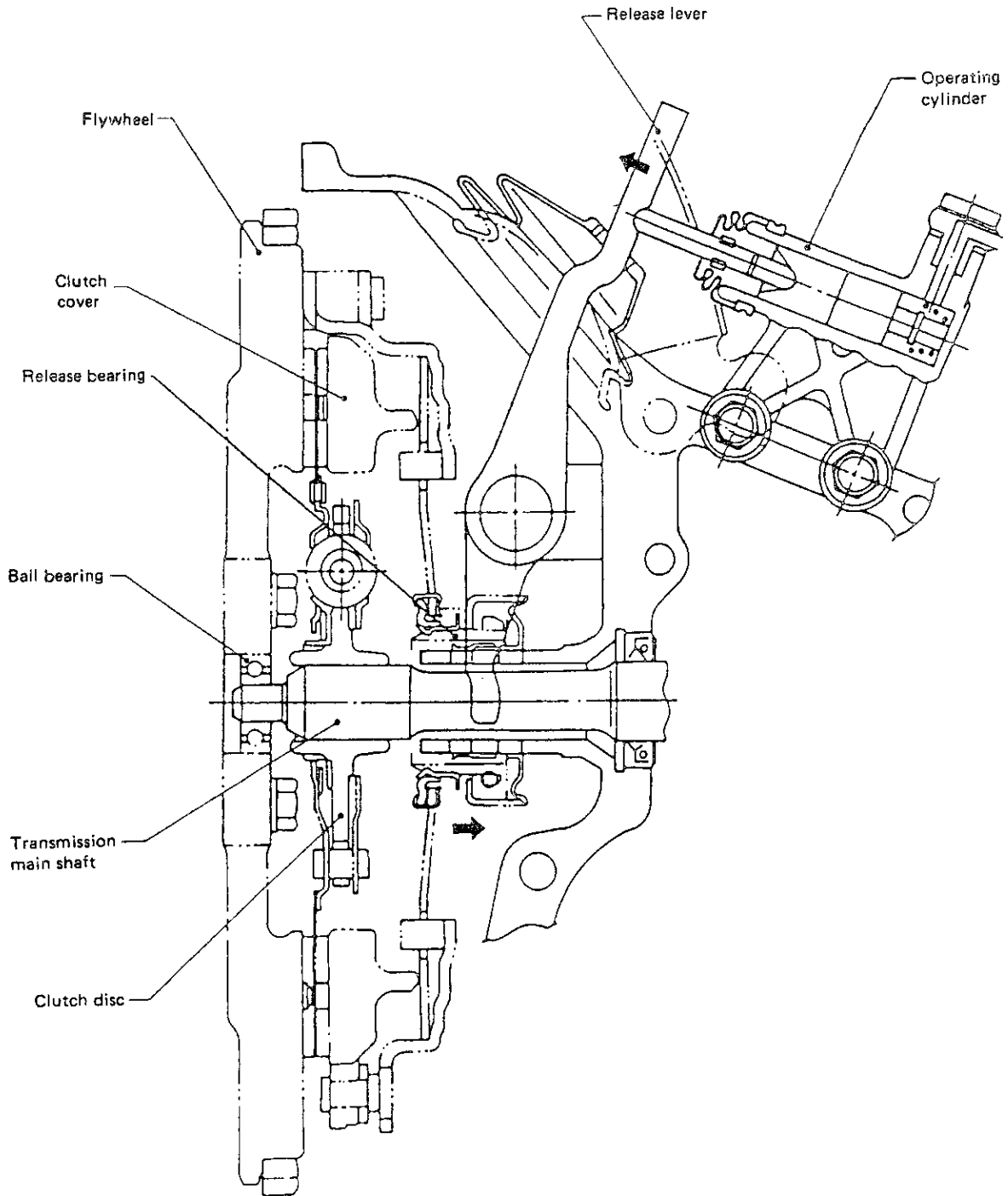


Fig. 2

52-636

S SPECIFICATIONS AND SERVICE DATA

A: SPECIFICATIONS

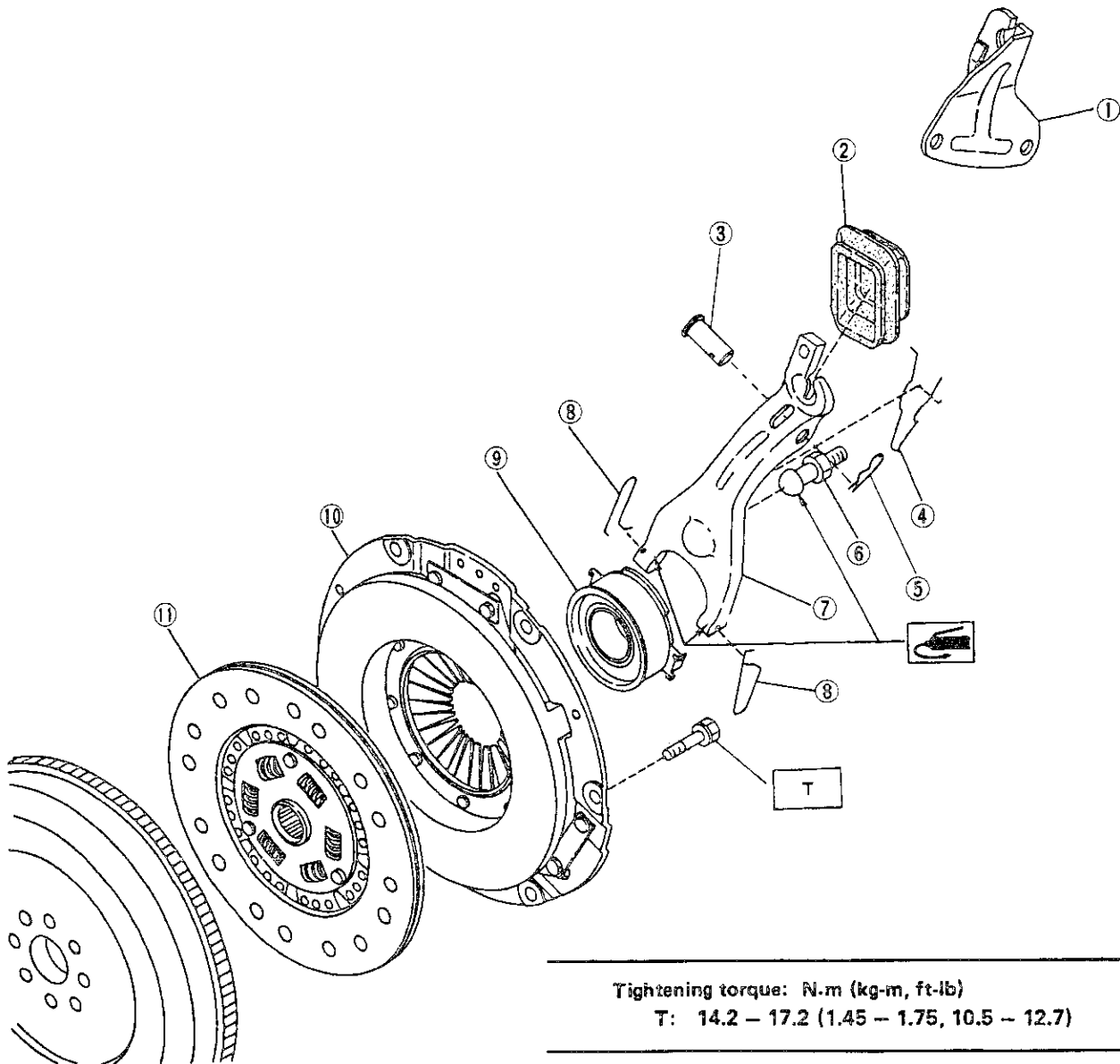
		1600 cc and 1800 cc FWD	1800 cc 4WD	2200 cc and 2000 cc	2000 cc Turbo
Clutch cover	Diaphragm set load kg (lb)	400 (882)		450 (992)	620 (1,367)
Clutch disc	Facing material	Woven			
	O.D. x I.D. x thickness mm (in)	200 x 130 x 3.5 (7.87 x 5.12 x 0.138)	225 x 150 x 3.5 (8.86 x 5.91 x 0.138)		
	Spline O.D. (No. of teeth)	22.22 (7/8) (21)	25.2 (0.992) (24)		
Clutch release lever ratio		3.0			1.7
Release bearing		Grease-packed self-aligning			

B: SERVICE DATA

			Non-Turbo	Turbo	
Clutch pedal	Full stroke	mm (in)	140 — 150 (5.51 — 5.91)	140 (5.51)	
Release lever	Stroke	mm (in)	24 — 26 (0.94 — 1.02)	13.3 — 14.7 (0.524 — 0.579)	
	Play at release lever center	mm (in)	3 — 4 (0.12 — 0.16)		
Clutch disc	Depth of rivet head	mm (in)	Standard	1.4 (0.055)	
			Limit of sinking	0.3 (0.012)	
	Limit for deflection	mm (in)	1800 cc 4WD, 2200 cc and 2200 cc	1.0 (0.039) at R = 107 (4.21)	
			1600 cc and 1800 cc FWD	0.8 (0.031) at R = 95 (3.74)	

C COMPONENT PARTS

1. Clutch System (Mechanical application type)



Tightening torque: N·m (kg·m, ft·lb)

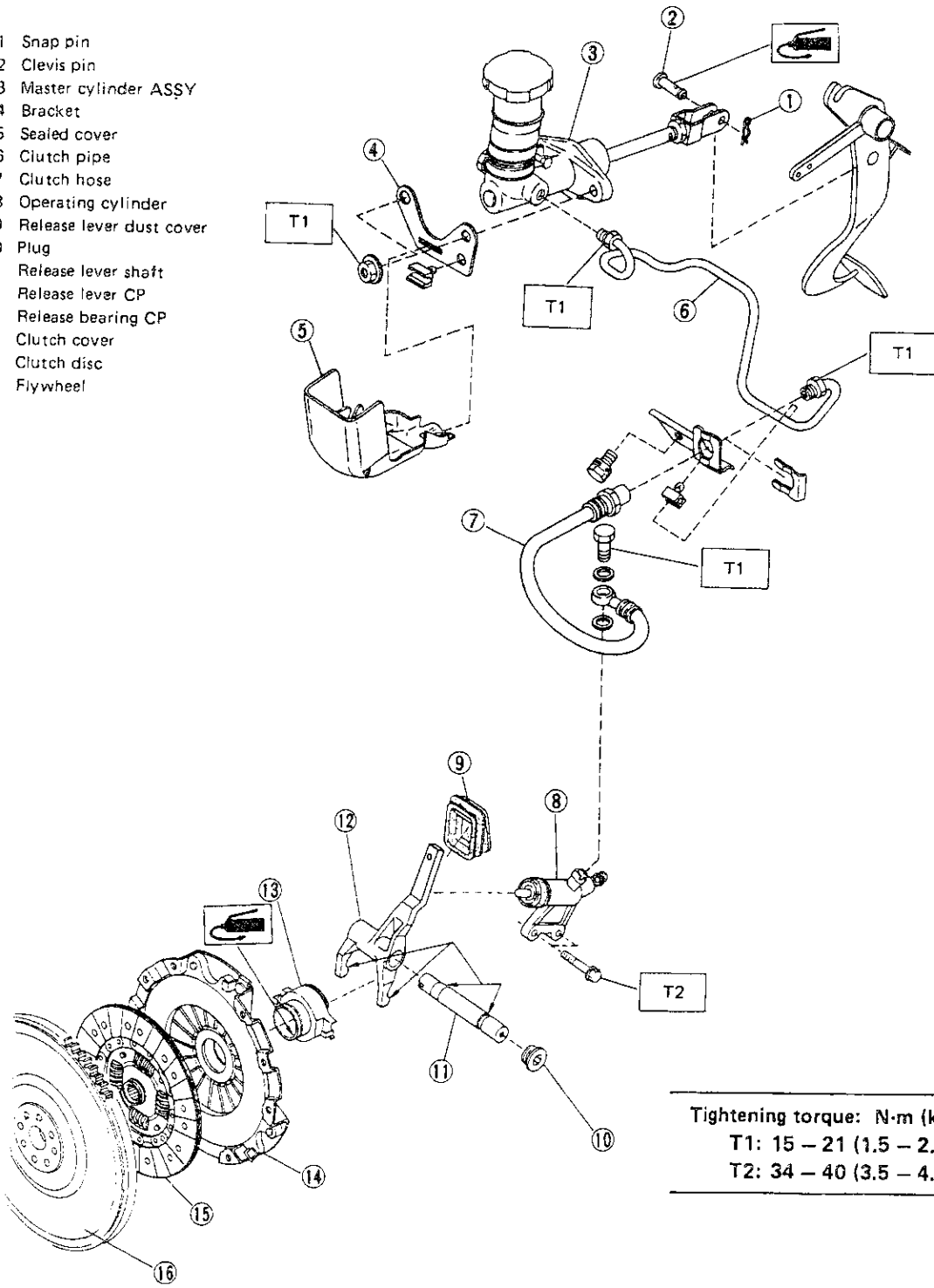
T: 14.2 – 17.2 (1.45 – 1.75, 10.5 – 12.7)

- 1 Clutch cable bracket
- 2 Clutch release lever sealing
- 3 Cable pin
- 4 Retainer spring
- 5 Snap ring
- 6 Pivot
- 7 Clutch release lever
- 8 Clip
- 9 Clutch release bearing
- 10 Clutch cover
- 11 Clutch disk

Fig. 3

2. Clutch System (Hydraulic application type)

- 1 Snap pin
- 2 Clevis pin
- 3 Master cylinder ASSY
- 4 Bracket
- 5 Sealed cover
- 6 Clutch pipe
- 7 Clutch hose
- 8 Operating cylinder
- 9 Release lever dust cover
- 10 Plug
- 11 Release lever shaft
- 12 Release lever CP
- 13 Release bearing CP
- 14 Clutch cover
- 15 Clutch disc
- 16 Flywheel



Tightening torque: N·m (kg·m, ft·lb)	
T1:	15 – 21 (1.5 – 2.1, 11 – 15)
T2:	34 – 40 (3.5 – 4.1, 25 – 30)

Fig. 4

B2-1116

**3. Master Cylinder and Reservoir Tank
(Hydraulic application type)**

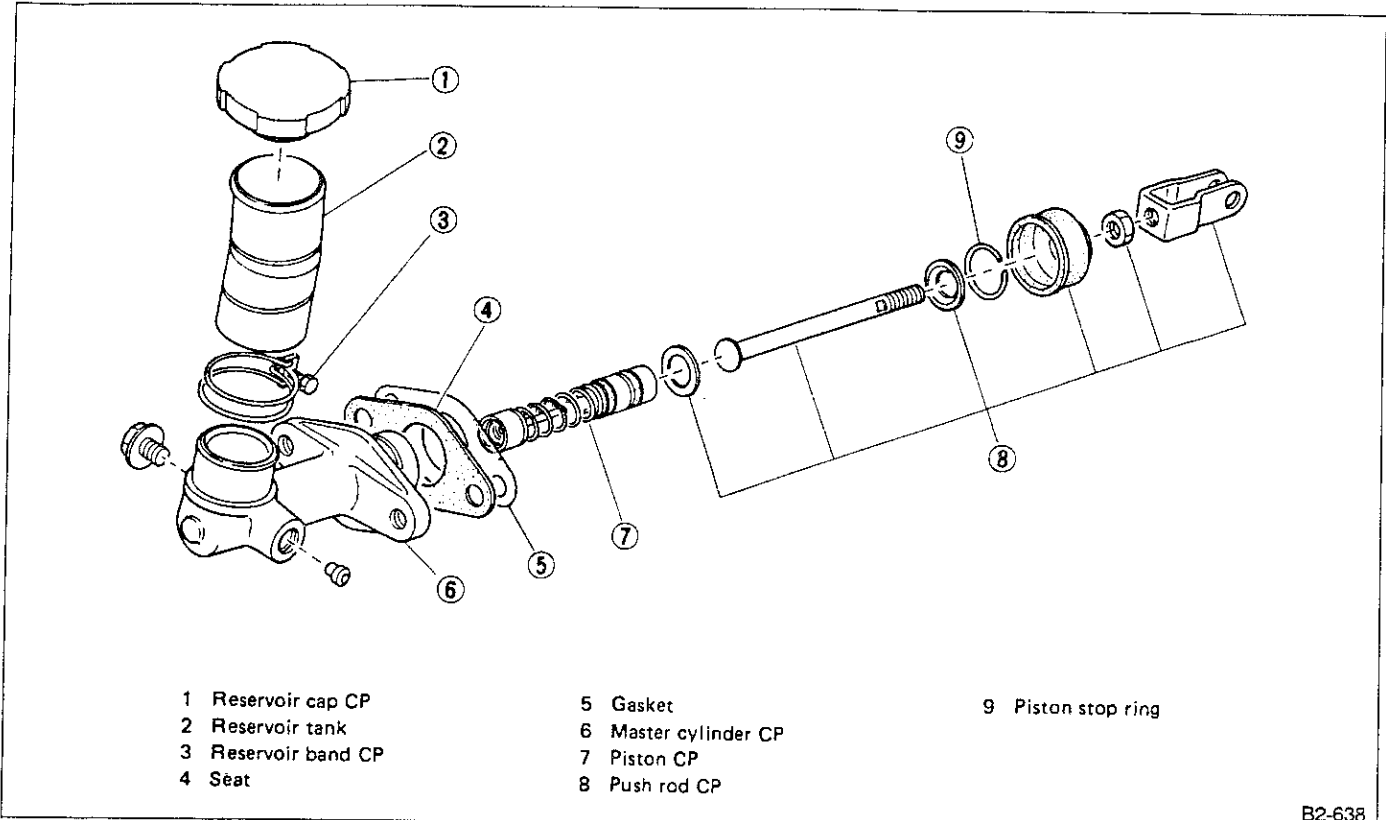


Fig. 5

B2-638

IV SERVICE PROCEDURE

I. General

A: PRECAUTION

When servicing clutch system, pay attention to the following items.

1. MECHANICAL APPLICATION TYPE

- 1) Check the routing of clutch cable for smoothness.
- 2) Excessive tightness or looseness of clutch cable have a bad influence upon the cable durability.
- 3) Apply grease sufficiently to the connecting portion of clutch pedal.
- 4) Apply grease sufficiently to the release lever portion.
- 5) Position clutch cable through the center of toeboard hole and route it smoothly. Adjustment is done by moving the outer cable.
- 6) Make sure not to let the clutch chatter when starting forward or rearward. If clutch chattering occurs, readjust so that the bend of clutch outer cable becomes flatter.

2. HYDRAULIC APPLICATION TYPE

- 1) Check fluid level using scale on outside of reservoir tank.
- 2) Make sure that clutch fluid does not leak from master cylinder, operating cylinder and piping.
- 3) Apply grease sufficiently to the release lever pinion.

B: ON-CAR SERVICE

1. MECHANICAL APPLICATION TYPE

- 1) Remove release lever return spring from lever.
- 2) Adjust spherical nut so that the play is within the specified value at the lever end (center of spherical nut).
Take care not to twist the cable during adjustment

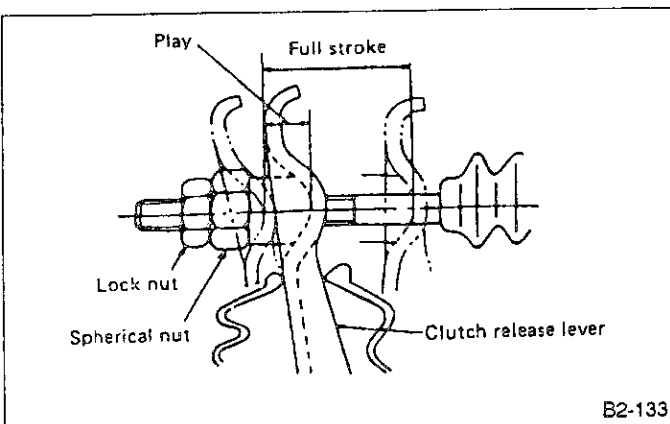


Fig. 6

Play: 3 — 4 mm (0.12 — 0.16 in)
Full stroke: 25.5 — 27 mm (1.004 — 1.063 in)

- 3) Upon completion of adjustment, securely lock spherical nut with lock nut.
- 4) Install return spring on lever.

Hook the long hook side of the return spring with the lever.

- 5) Depress clutch pedal to assure there is no abnormality in the clutch system.

2. HYDRAULIC APPLICATION TYPE

Bleed air from oil line with the help of a co-worker.

- 1) Fit one end of a vinyl tube into the air bleeder of operating cylinder and put the other end into a clutch fluid container.

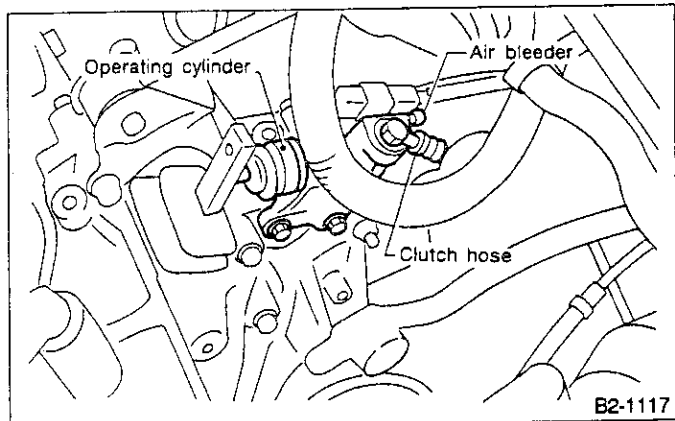


Fig. 7

- 2) Slowly depress the clutch pedal and keep it depressed. Then open the air bleeder to discharge air together with the fluid. Release the air bleeder for 1 or 2 seconds. Next, with the bleeder closed, slowly release the clutch pedal.
- 3) Repeat these steps until there are no more air bubbles in the vinyl tube.

Cover bleeder with waste cloth when loosening it, to prevent clutch fluid from being splashed over surrounding parts.

- 4) Tighten air bleeder.

Tightening torque:

15 — 21 N·m (1.5 — 2.1 kg-m, 11 — 15 ft-lb)

- 5) After depressing the clutch pedal, make sure that there are no leaks evident in the entire system.

2. Release Bearing and Lever

A: REMOVAL

1. MECHANICAL APPLICATION TYPE

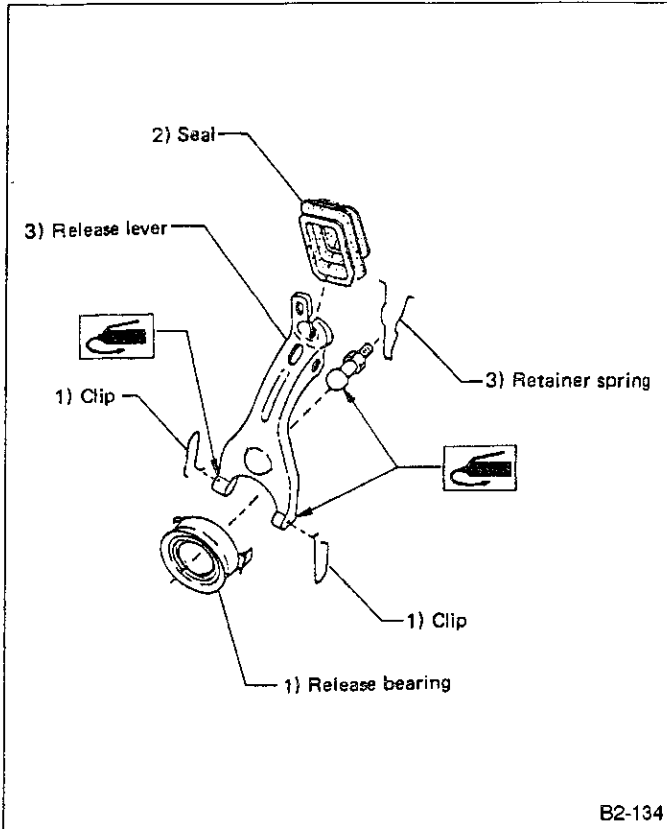


Fig. 8

1) Remove the two clips from clutch release lever and remove release bearing.

Be careful not to deform clips.

2) Remove release lever seal.

3) Remove release lever retainer spring from release lever pivot with a screwdriver by accessing it through clutch housing release lever hole. Then remove release lever.

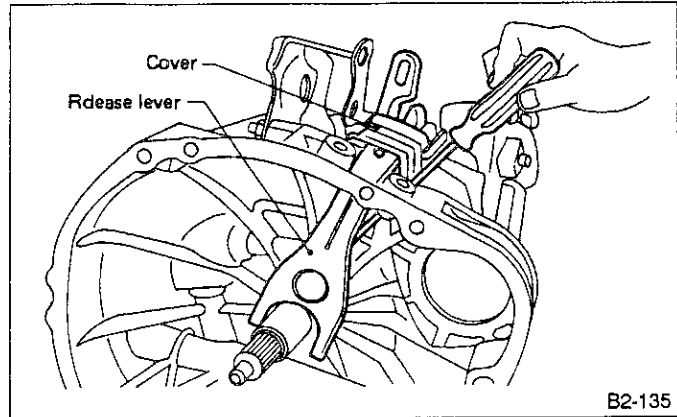


Fig. 9

2. HYDRAULIC APPLICATION TYPE

Remove release bearing and lever after separating engine and transmission.

Refer to "2-11 Engine and Transmission Mounting System".

1) Remove release lever from transmission.

2) Put release bearing in engine side.

3) Remove release bearing from clutch cover using flat-type screwdriver.

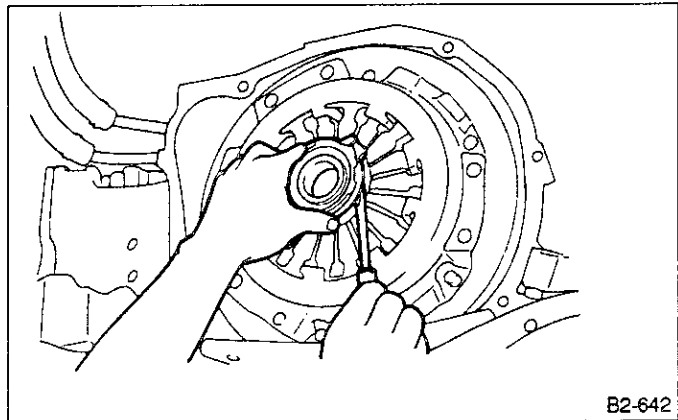
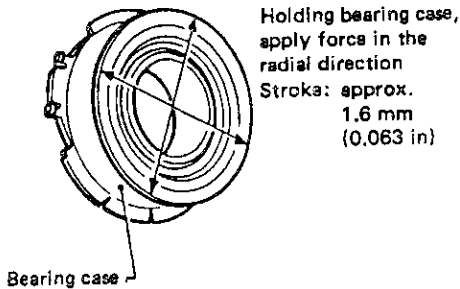


Fig. 10

B: INSPECTION**RELEASE BEARING**

Since this bearing is grease sealed and is of a non-lubrication type, do not wash with gasoline or any solvent when servicing the clutch.

- 1) Check the bearing for smooth movement by applying force in the radial direction.



B2-136

Fig. 11

- 2) Check the bearing for smooth rotation by applying pressure in the thrust direction.
- 3) Check wear and damage of holder surface contacting with lever.

2. RELEASE LEVER

Check lever pivot portion and the point of contact with holder for wear.

C: INSTALLATION

Before or during assembling, lubricate the following points with a light coat of grease.

- a. Inner groove of release bearing.
- b. Contact surface of lever and pivot.
- c. Contact surface of lever and bearing.
- d. Transmission main shaft spline. (Use grease containing molybdenum disulphide.)

1. MECHANICAL APPLICATION TYPE

- 1) Install retainer spring into lever.
- 2) While pushing lever to pivot and twisting it to both sides, fit retainer spring onto the constricted portion of pivot.

Confirm that retainer spring is securely fitted by observing it through the main case hole.

- 3) Install release bearing and fasten it with two clips.

- 4) Install release lever sealing.
- 5) After remounting engine and transmission on body, make adjustment of the clutch release lever end play.

Take care not to twist the cable during adjustment.

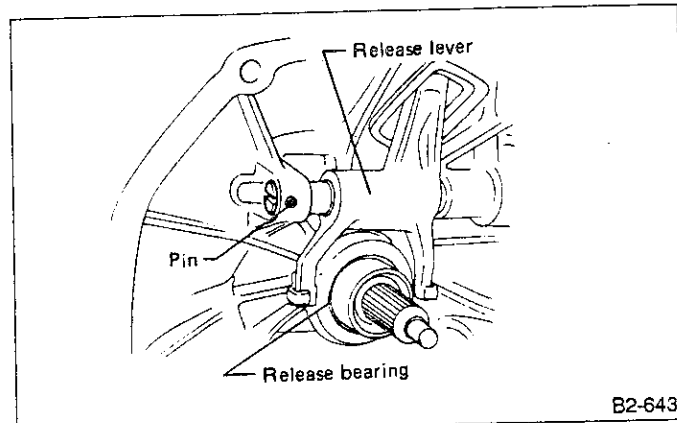
- 6) Install release lever return spring.

Hook up the long hook side of the return spring with the lever.

2. HYDRAULIC APPLICATION TYPE

- 1) Position both release lever and bearing on transmission.
- 2) Install release lever shaft.

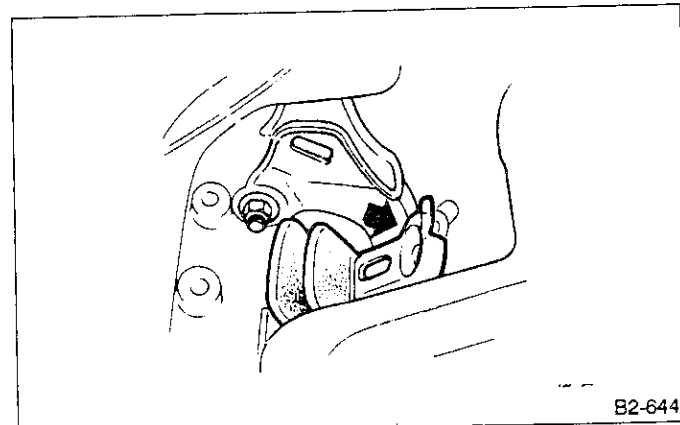
Be sure to fit groove on release lever shaft into pin located at through-hole.



B2-643

Fig. 12

- 3) With release lever held in that position, connect engine and transmission.
- 4) Push release lever to fit bearing into clutch cover.



B2-644

Fig. 13

- 5) Install plug.

Tightening torque:

41 — 47 N·m (4.2 — 4.8 kg-m, 30 — 35 ft-lb)

3. Clutch Disc and Cover

A: REMOVAL

- 1) Install CRANKSHAFT STOPPER on flywheel.

Special tool:

CRANKSHAFT STOPPER (498497100)

- 2) Remove clutch cover and clutch disc.
 - a. Take care not to allow oil on the clutch disc facing.
 - b. Do not disassemble either clutch cover CP or clutch disc CP.
- 3) Remove flywheel.

B: INSPECTION

1. CLUTCH DISC

- 1) Facing wear
Measure the depth of rivet head from the surface of facing. Replace if facings are worn locally or worn down to less than the specified value.

Depth of rivet head

Standard value 1.4 mm (0.055 in)
Limit of sinking 0.3 mm (0.012 in)

Do not wash clutch disc with any cleaning fluid.

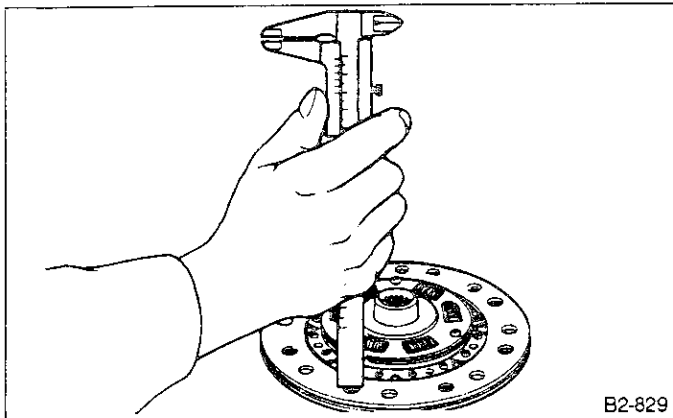


Fig. 14

- 2) Hardened facing
Correct by using emery paper or replace.
- 3) Oil soakage on facing
Replace clutch disc and inspect transmission front oil seal, transmission case mating surface, engine rear oil seal and other points for oil leakage.
- 4) Deflection on facing
If deflection exceeds the specified value at the outer circumference of facing, repair or replace.

Limit for deflection:

1.0 mm (0.039 in) at R = 107 mm (4.21 in)

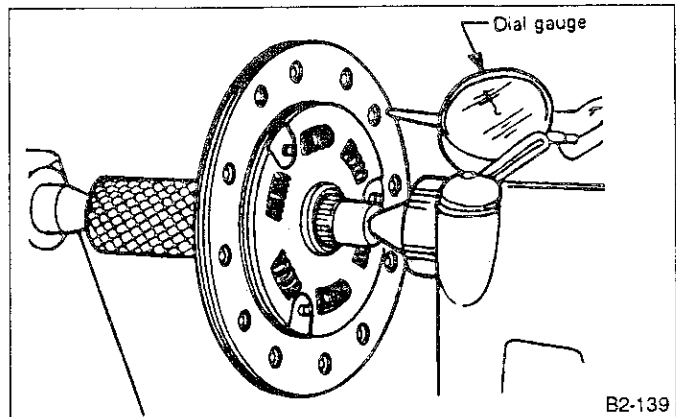


Fig. 15

- 5) Worn spline, loose rivets and torsion spring failure
Replace defective parts.

2. CLUTCH COVER

Visually check for the following items without disassembling, and replace or repair if defective.

- 1) Loose thrust rivet.
- 2) Damaged or worn bearing contact area at center of diaphragm spring.
- 3) Damaged or worn disc contact surface of pressure plate.
- 4) Loose strap plate setting bolt.
- 5) Worn diaphragm sliding surface.

3. FLYWHEEL

Since this bearing is grease sealed and is of a nonlubrication type, do not wash with gasoline or any solvent.

- 1) Damage of facing and ring gear If defective, replace flywheel.
- 2) Smoothness of rotation
Rotate ball bearing applying pressure in thrust direction.

If noise or excessive play is noted, replace ball bearing as follows:

- (1) Drive out ball bearing from flywheel.
- (2) Press bearing into flywheel until bearing end surface is flush with clutch disc contact surface of flywheel. Do not press inner race.

Special tool:

SNAP RING PRESS (899754112)

C: INSTALLATION

- 1) Install flywheel.
- 2) Install CRANKSHAFT STOPPER, and tighten the flywheel attaching bolts to the specified torque.

Tightening torque:

69 — 75 N·m (7.0 — 7.6 kg-m, 51 — 55 ft-lb)

- 3) Insert CLUTCH DISC GUIDE into the clutch disc and install them on the flywheel by inserting the GUIDE end into the pilot bearing.

Special tool:

CLUTCH DISC GUIDE (499747100)

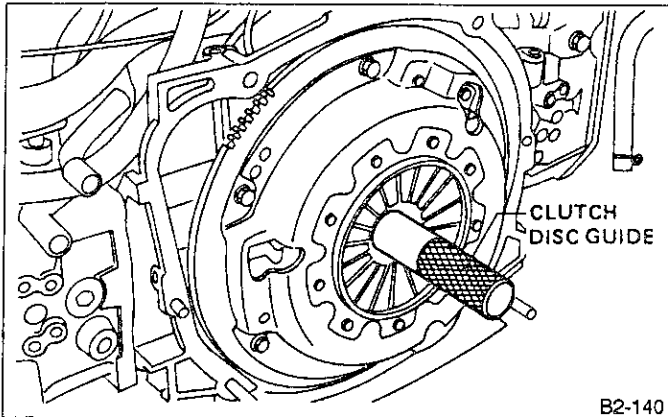


Fig. 16

- 4) Install clutch cover CP on flywheel and tighten bolts to the specified torque.

Tightening torque:

14.2 — 17.2 N·m

(1.45 — 1.75 kg-m, 10.5 — 12.7 ft-lb)

a. When installing the clutch cover on the flywheel, position the clutch cover so that there is a gap of 120° or more between "0" marks on the flywheel and clutch cover. ("0" marks indicate the directions of residual unbalance.)

b. Note the front and rear of the clutch disc when installing.

c. Tighten clutch cover installing bolts gradually. Each bolt should be tightened in a crisscross fashion to the specified torque.

4. Operating Cylinder (Hydraulic application type only)**A: REMOVAL AND INSTALLATION**

- 1) Remove intercooler.
 - (1) Separate intercooler from throttle body.
 - (2) Separate air outlet duct from turbocharger unit.
 - (3) Remove intercooler from bracket.
 - (4) Place intercooler on the left side wheel apron.

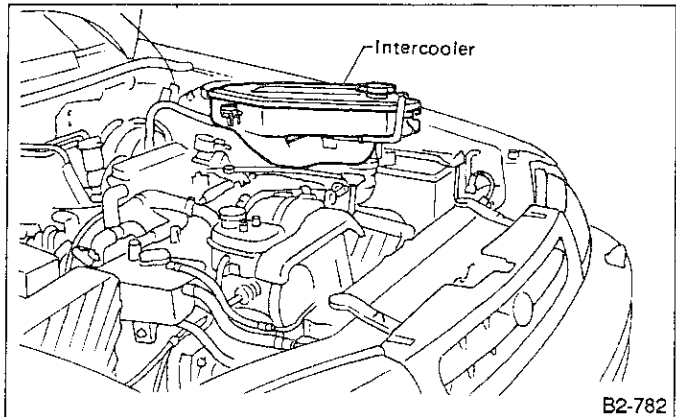


Fig. 17

- 2) Remove clutch pipe from operating cylinder. Cover hose joint to prevent clutch fluid from flowing out.
- 3) Remove operating cylinder from transmission.

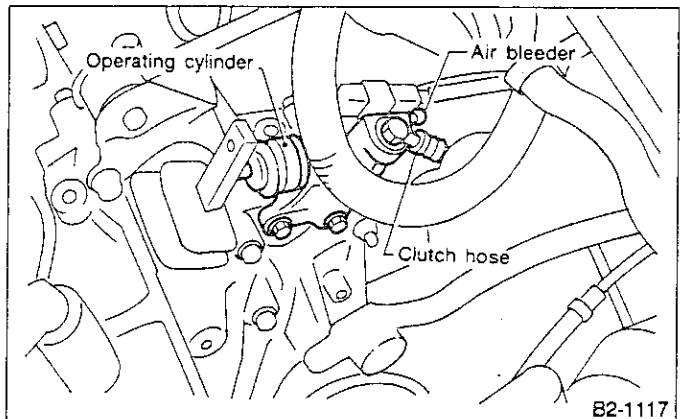


Fig. 18

- 4) Installation is in the reverse order of removal.

Tightening torque:**Clutch hose**

13 — 18 N·m (1.3 — 1.8 kg-m, 9 — 13 ft-lb)

To transmission

34 — 40 N·m (3.5 — 4.1 kg-m, 25 — 30 ft-lb)

5. Master Cylinder and Reservoir Tank (Hydraulic application type only)

A: REMOVAL

- 1) Remove snap pin, and separate push rod of master cylinder from clutch pedal.
- 2) Remove clutch pipe from master cylinder.
Plug up hose connection to prevent clutch fluid from spilling out.
- 3) Remove master cylinder with reservoir tank.

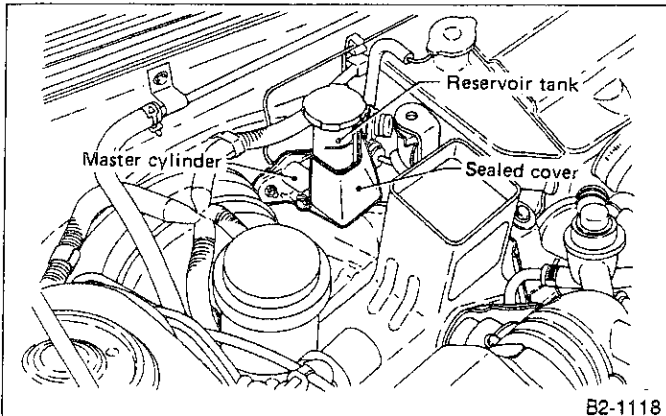


Fig. 19

B: INSPECTION

If any damage, deformation, wear, swelling, rust or other faults are found on the cylinder CP, piston CP, push rod CP, fluid reservoir, seat and gasket, replace the faulty part.

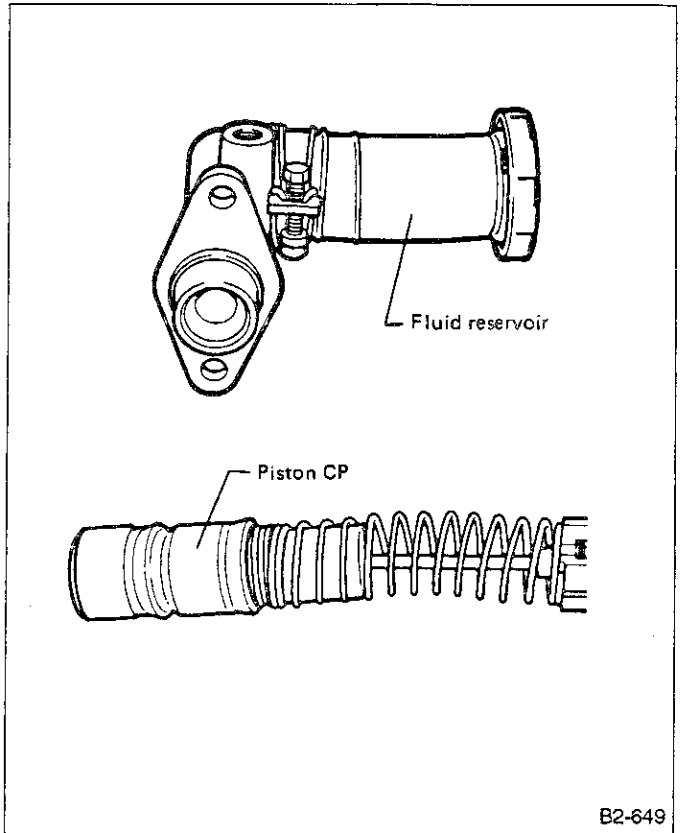


Fig. 20

C: INSTALLATION

- 1) Install master cylinder to body.
Always use a new gasket.
- 2) Install clutch hose to master cylinder.
Check that hose is routed properly.

Tightening torque:

Clutch hose

15 — 21 N·m (1.5 — 2.1 kg-m, 11 — 15 ft-lb)

To body

15 — 21 N·m (1.5 — 2.1 kg-m, 11 — 15 ft-lb)

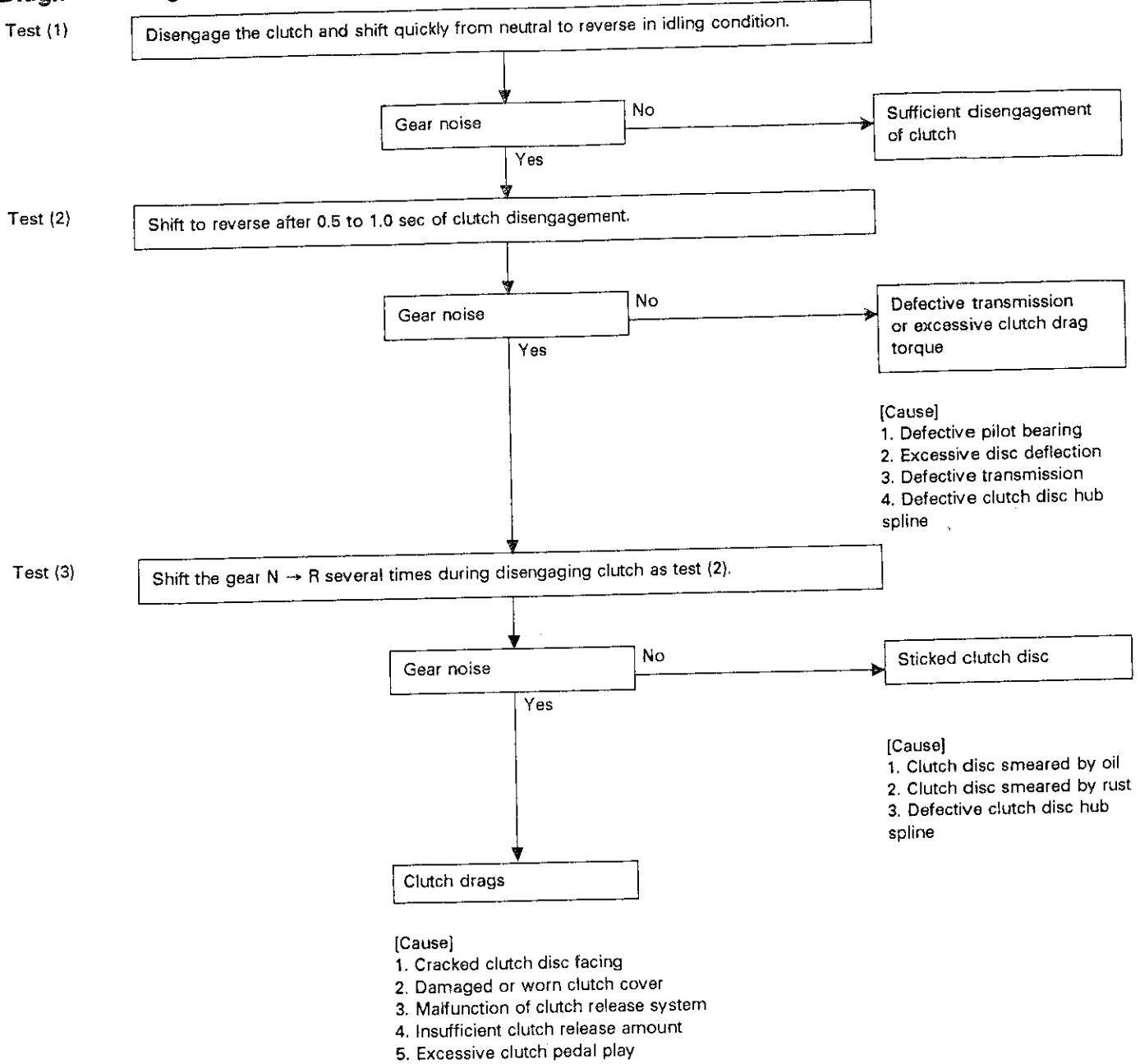
- 3) Connect push rod of master cylinder to clutch pedal, and install clevis pin and snap pin.

T TROUBLESHOOTING

Condition	Possible cause and testing	Corrective action
1. Clutch slip- page	It is hard to perceive clutch slippage in the early stage, but pay attention to the following symptoms.	
	<p>(a) Engine revs up when shifting.</p> <p>(b) High speed driving is impossible; especially rapid acceleration impossible and vehicle speed does not increase in proportion to an increase in engine speed.</p> <p>(c) Power falls, particularly when ascending a slope, and there is a smell of burning of the clutch facing.</p> <p>• Method of testing: Put the car in stationary condition with parking brake fully applied. Disengage the clutch and shift the transmission gear into the first. Gradually allow the clutch to engage while gradually increasing the engine speed. The clutch function is satisfactory if the engine stalls. However, the clutch is slipping if the car does not start off and the engine does not stall.</p>	
	(a) No clutch pedal play	Readjust.
	(b) No release lever end play	Readjust.
	(c) Clutch facing smeared by oil	Replace.
	(d) Worn clutch facing	Replace.
	(e) Deteriorated diaphragm spring	Replace.
	(f) Distorted pressure plate or flywheel	Correct or replace.
	(g) Defective release bearing holder	Correct or replace.
	(h) Defective pedal and cable system	Correct or replace.
2. Clutch drags	As a symptom of this trouble, a harsh scratching noise develops and control becomes quite difficult when shifting gears. The symptom becomes more apparent when shifting into the first gear. However, because much trouble of the this sort is due to defective synchronization mechanism, carry out the test as described after.	
	<p>• Method of testing: Refer to diagnostic diagram on page after.</p> <p>It may be judged as insufficient disengagement of clutch if any noise occurs during this test.</p>	
	(a) Excessive clutch pedal play	Readjust.
	(b) Excessive clutch release lever play	Readjust.
	(c) Worn or rusty clutch disc hub spline	Replace clutch disc.
	(d) Excessive deflection of clutch disc facing	Correct or replace.
	(e) Seized crankshaft pilot needle bearing	Replace.
	(f) Malfunction of pedal and cable system	Correct or replace.
	(g) Cracked clutch disc facing	Replace.
	(h) Sticked clutch disc (smeared by oil or water)	Replace.
3. Clutch chat- ters	Clutch chattering is an unpleasant vibration to the whole body when the vehicle is just started with clutch partially engaged.	
	<p>(a) Improper clutch cable routing</p> <p>(b) Adhesion of oil on the facing</p> <p>(c) Weak or broken torsion spring</p> <p>(d) Defective facing contact or excessive disc</p> <p>(e) Warped pressure plate or flywheel</p> <p>(f) Loose disc rivets</p> <p>(g) Loose engine mounting</p> <p>(h) Improper adjustment of pitching stopper</p>	<p>Correct.</p> <p>Replace clutch disc.</p> <p>Replace clutch disc.</p> <p>Replaces clutch disc. deflection</p> <p>Correct or replace.</p> <p>Replace clutch disc.</p> <p>Retighten or replace mounting.</p> <p>Adjustment.</p>

4. Noisy clutch	Examine whether the noise is generated when the clutch is disengaged, engaged, or partially engaged.	
	(a) Broken, worn or unlubricated release bearing	Replace release bearing.
	(b) Insufficient lubrication of pilot bearing	Apply grease.
	(c) Loose clutch disc hub	Replace clutch disc.
	(d) Loose torsion spring retainer	Replace clutch disc.
	(e) Deteriorated or broken torsion spring	Replace clutch disc.
5. Clutch grabs	When starting the vehicle with the clutch partially engaged, the clutch engages suddenly and the car jumps instead of making a smooth start.	
	(a) Grease or oil on facing	Replace clutch disc.
	(b) Deteriorated cushioning spring	Replace clutch disc.
	(c) Worn or rusted spline of clutch disc or main	Take off rust, apply grease or replace clutch shaft disc or mainshaft.
	(d) Deteriorated or broken torsion spring	Replace clutch disc.
	(e) Loose engine mounting	Retighten or replace mounting.
	(f) Deteriorated diaphragm spring	Replace.

Diagnostic Diagram of Clutch Drags



SUBARU.

1992

**SERVICE
MANUAL**

	Page
C COMPONENT PARTS	2
1. Engine Mounting	2
2. Transmission Mounting	3
W SERVICE PROCEDURE	5
1. General Precaution	5
2. Engine	6
3. Transmission	24



C COMPONENT PARTS

1. Engine Mounting

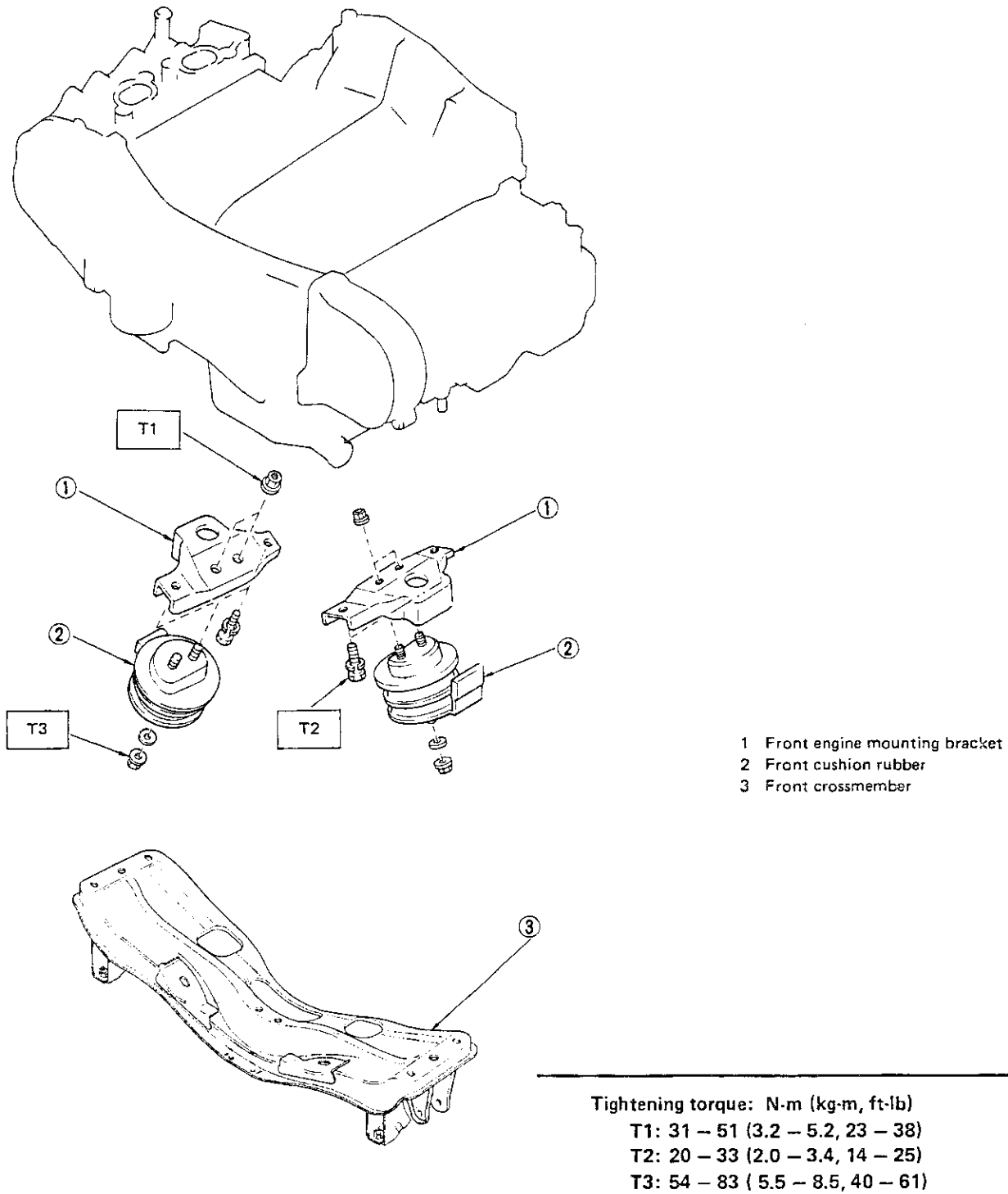


Fig. 1

B2-767

2. Transmission Mounting

1. MT MODEL

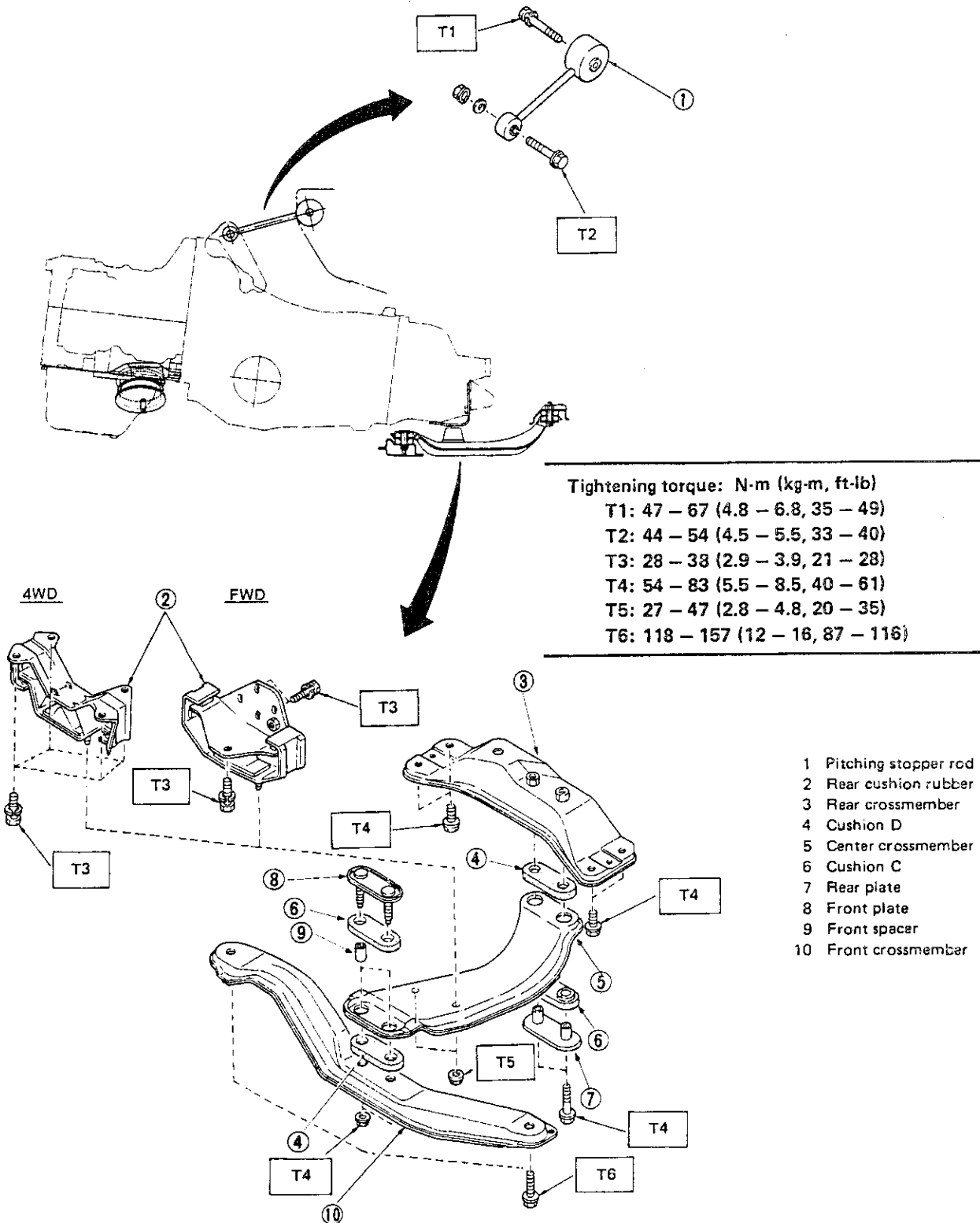
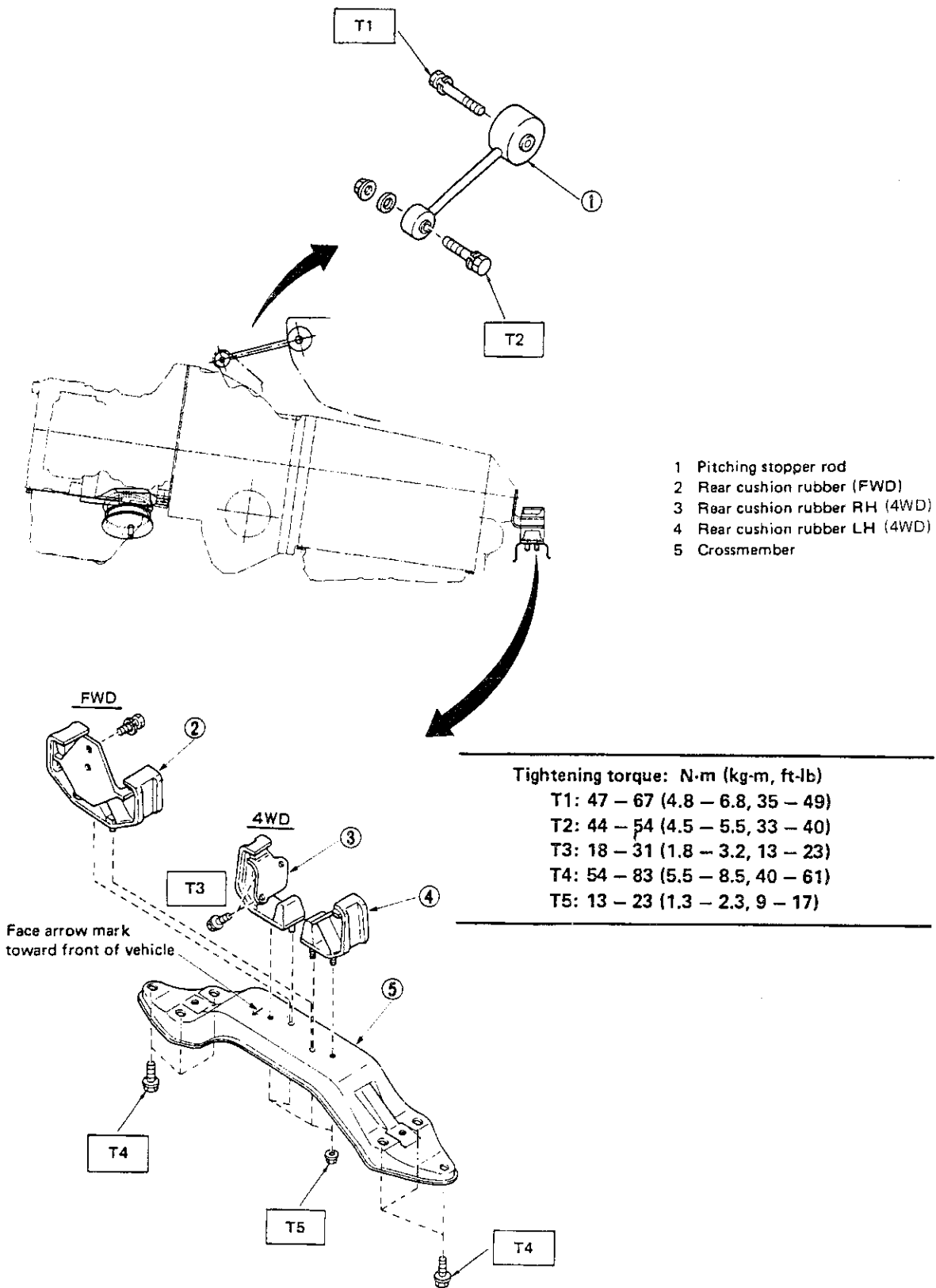


Fig. 2

B2-768L

2. AT MODEL



B2-769L

Fig. 3

W SERVICE PROCEDURE

1. General Precaution

- 1) Remove or install engine and transmission in an area where chain hoists, lifting devices, etc. are available for ready use.
- 2) Be sure not to damage coated surfaces of body panels with tools or stain seats and windows with coolant or oil. Place a cover over fenders, as required, for protection.
- 3) Prior to starting work, prepare the following:
Service tools, clean cloth, containers to catch coolant and oil, wire ropes, chain hoist, transmission jacks, etc.
- 4) Lift up or lower the vehicle when necessary. Make sure to support the correct positions. (Refer to Chapter 1-3 "General Information".)

2. Engine

A: REMOVAL

1. Set the vehicle on lift arms.
2. Open front hood and support with a stay.

3. Release fuel pressure.
4. Disconnect battery cable and remove battery from vehicle.
5. Drain coolant.

6. Remove cooling system.
 - Radiator and fan ASSY
 - Reservoir tank [Non-Turbo]

Turbo model

7. Remove intercooler.

A/C equipped model

8. Collect refrigerant, and remove pressure hose.

9. Remove air intake system.
 - Air intake duct [Non-Turbo]
 - Resonator chamber [Turbo]
 - Air inlet duct [Turbo]
10. Remove air cleaner upper cover and element.

Turbo model

11. Remove turbocharger cooling duct.

12. Remove canister and bracket.

13. Disconnect connectors, cables and hoses.

14. Remove power steering pump from bracket.

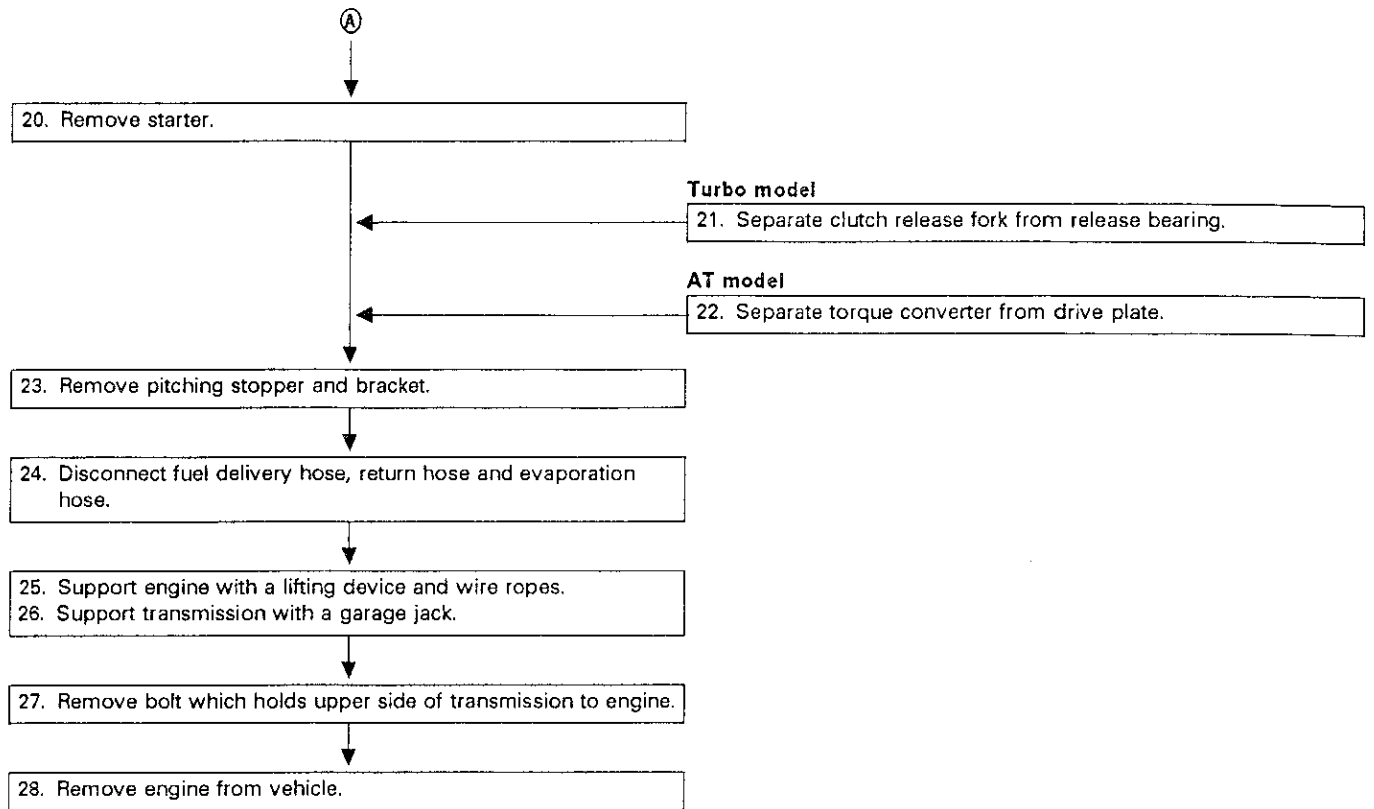
Turbo model

15. Separate turbocharger unit from center exhaust pipe.

16. Remove exhaust system.
 - Front exhaust pipe [Non-Turbo]
 - Turbocharger lower cover [Turbo]
 - Center exhaust pipe [Turbo]

17. Remove nut which installs lower side of starter.
18. Remove nuts which hold lower side of transmission to engine.
19. Remove nuts which install front cushion rubber onto front crossmember.

Ⓐ



- 1) Set the vehicle on lift arms.
- 2) Open front hood fully and support with stay.

Refer to C. 1-3.

- 3) Release fuel pressure.
 - (1) Disconnect fuel pump connector.
 - (2) Start the engine, and run until it stalls.
 - (3) After the engine stalls, crank it for five seconds more.
 - (4) Turn ignition switch to "OFF".

Refer to C. 2-8 [W101].

- 4) Disconnect battery cables and remove battery from vehicle.

- 5) Drain coolant.
 - (1) Fit vinyl tube onto drain pipe.
 - (2) Loosen drain cock, and drain coolant.

Drain coolant into container.

- 6) Remove cooling system.
 - (1) Disconnect radiator fan motor connector.
 - (2) Disconnect radiator outlet hose from thermostat cover.
 - (3) Disconnect ATF cooler hoses from pipes. [AT]

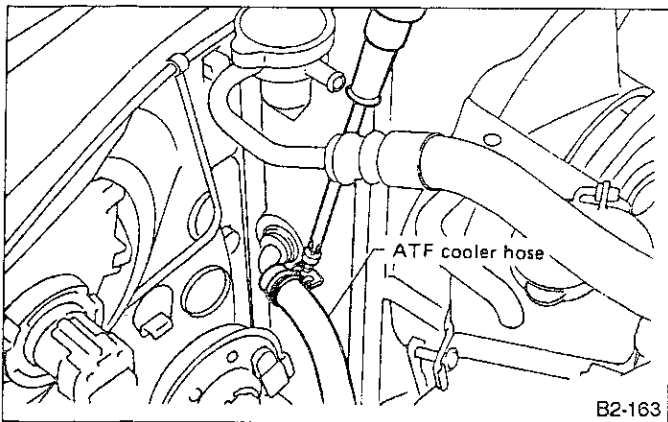


Fig. 4

- (4) Remove V-belt cover.
- (5) Disconnect radiator inlet hose from water pipe.
- (6) Remove radiator upper bracket, and remove radiator ASSY from vehicle.

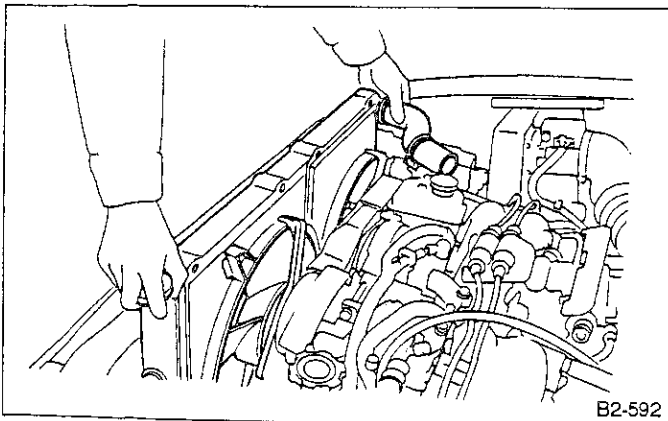


Fig. 5

- (7) Remove reservoir tank [Non-Turbo].
- 7) Remove intercooler.
 - (1) Remove front grille.
 - (2) Drain coolant from intercooler radiator.
 - (3) Fit end of vinyl tube in drain pipe.
 - (4) Loosen drain cock and drain coolant.

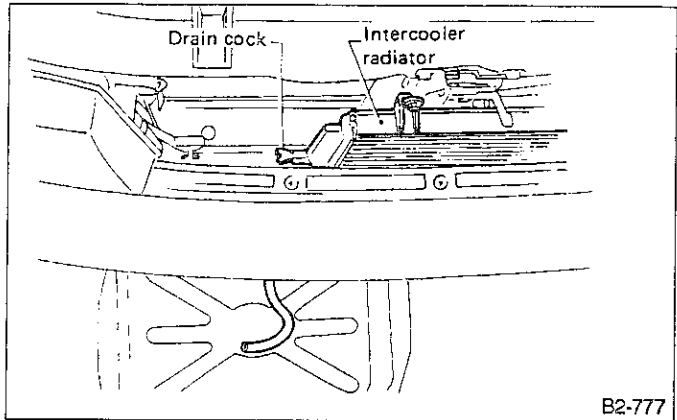


Fig. 6

a. Drain coolant into container.

b. While draining coolant, remove intercooler cap.

- (5) Separate intercooler from throttle body and turbocharger unit.
- (6) Remove water hoses from pipes.
- (7) Remove intercooler from vehicle.

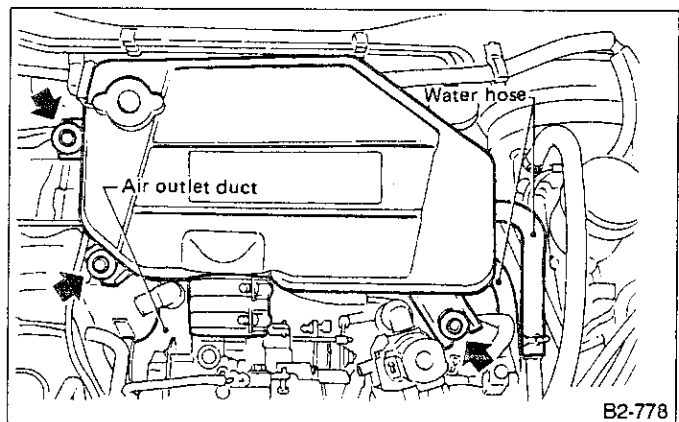


Fig. 7

8) Collect refrigerant, and remove pressure hoses. [A/C equipped model]

- (1) Place and connect the attachment hose to the refrigerant recycle system.
- (2) Collect refrigerant from A/C system.
- (3) Disconnect pressure hose from A/C compressor.

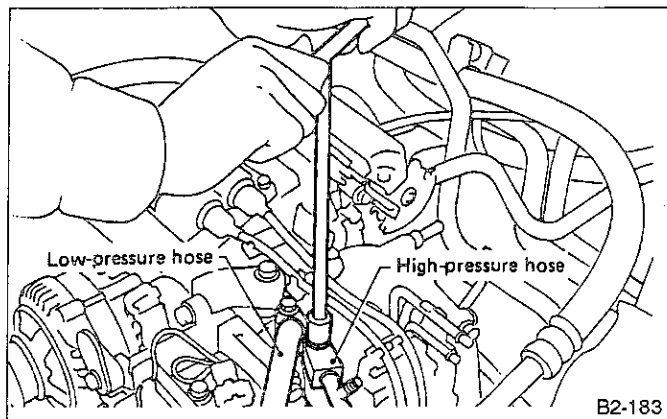


Fig. 8

9) Remove air intake system.

- (1) Remove air intake duct. [Non-Turbo]

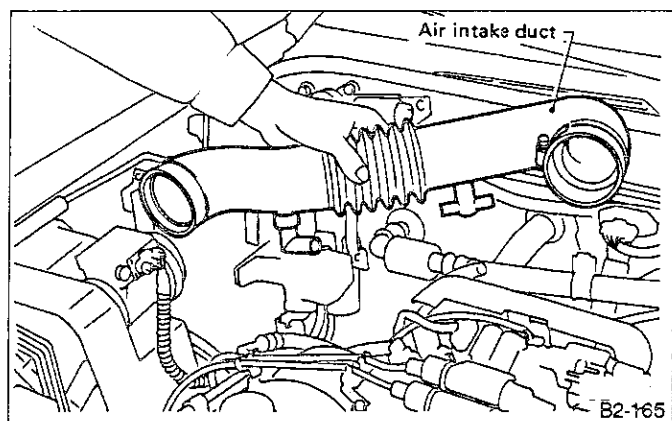


Fig. 9

- (2) Remove resonator chamber. [Turbo]

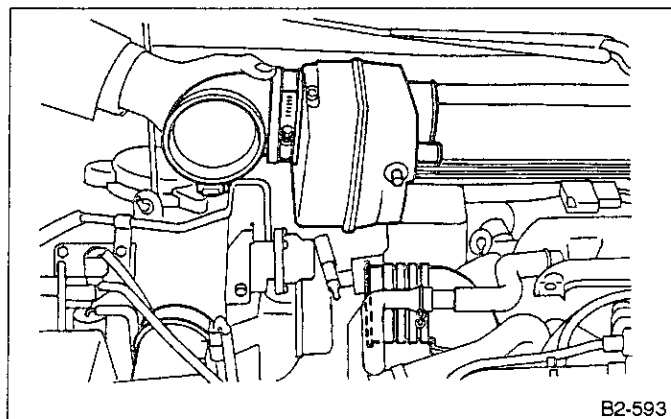


Fig. 10

- (3) Remove air inlet duct. [Turbo]

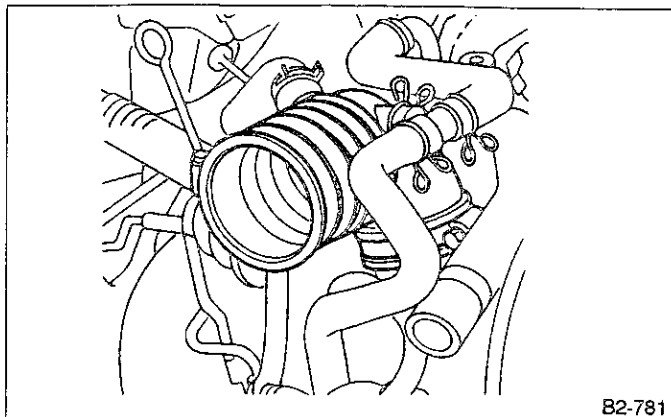


Fig. 11

- 10) Remove air cleaner upper cover and element.

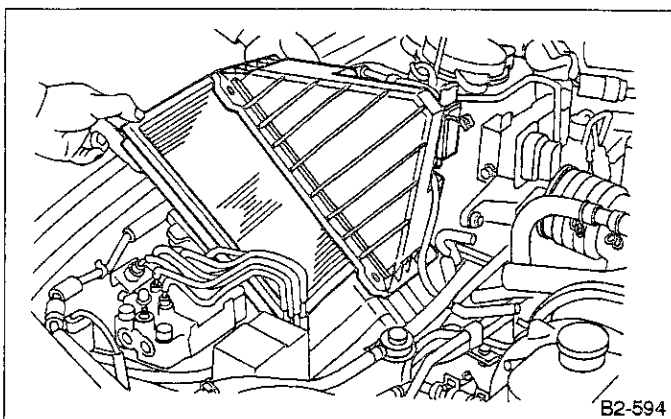


Fig. 12

- 11) Remove turbocharger cooling duct. [Turbo]

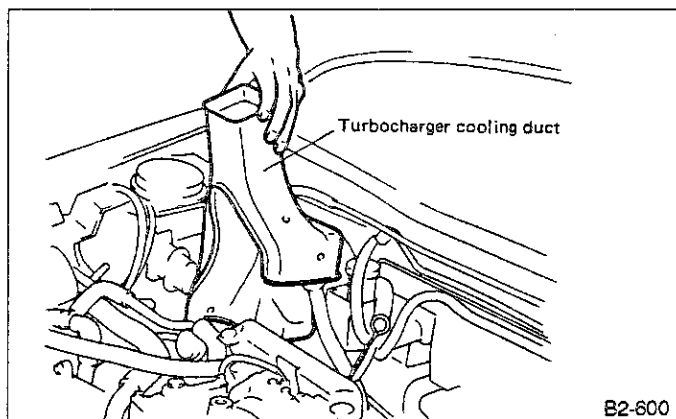


Fig. 13

12) Remove canister and bracket.

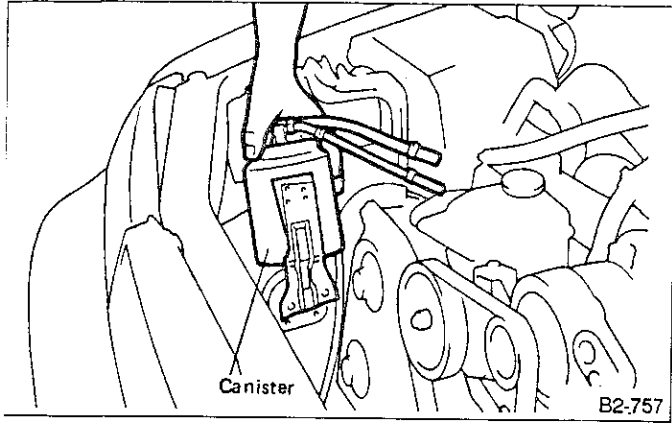
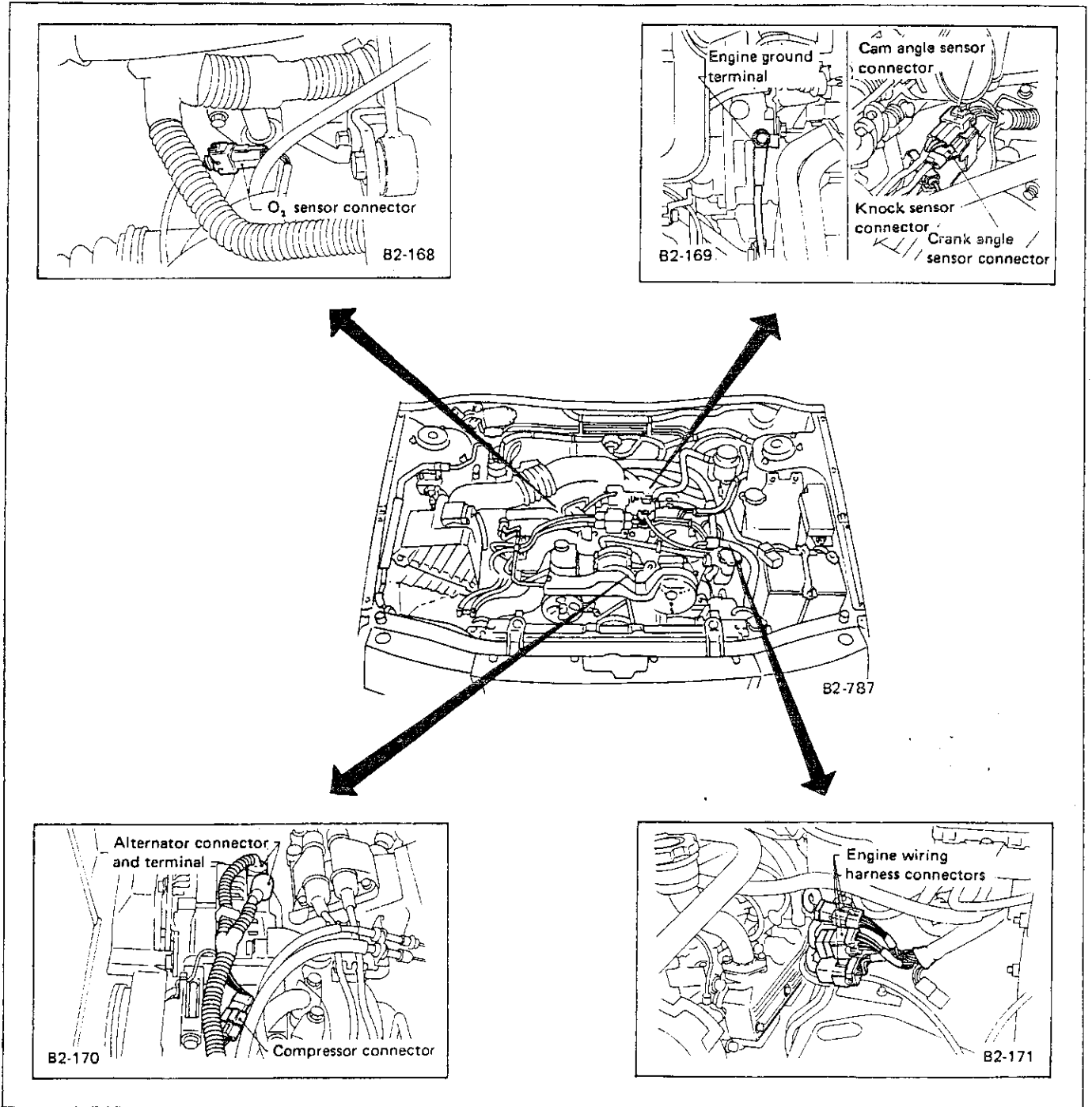


Fig. 14

13) Disconnect connectors, cables and hoses.

(1) Disconnect the following connectors.

- Engine harness connectors
- O₂ sensor connector
- Vehicle speed sensor 2 [Turbo]
- Engine ground terminal
- Crank angle sensor connector
- Cam angle sensor connector
- Knock sensor connector
- Alternator connector and terminal
- A/C compressor connectors [A/C equipped model]



B2-779

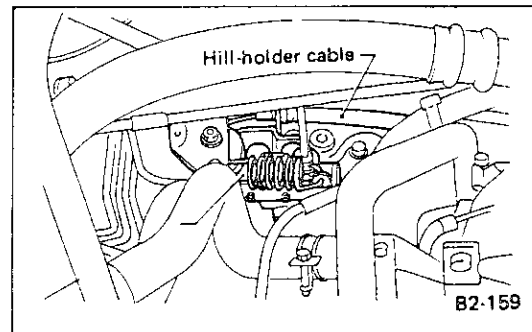
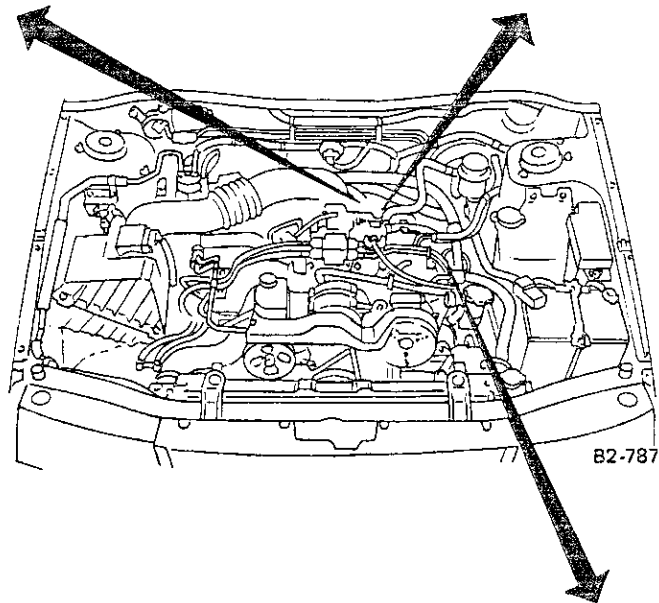
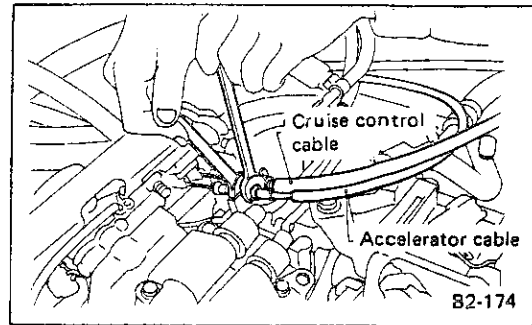
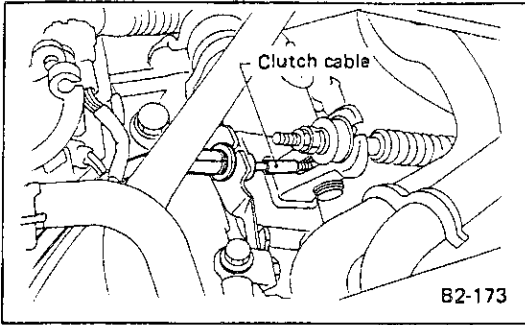
Fig. 15

(2) Disconnect the following cables.

- Accelerator cable
- Cruise control cable
- Clutch release spring

- Clutch cable [Non-Turbo MT]
- Hill-holder cable [Non-Turbo MT]

Disconnect hill-holder cable at connection on clutch release fork side and transfer it to PHV side.



B2-789

Fig. 16

(3) Disconnect the following hoses.

- Brake booster vacuum hose
- Heater inlet and outlet hoses
- Coolant filler tank hoses [Turbo]
- Turbocharger pressure control vacuum hoses [Turbo]

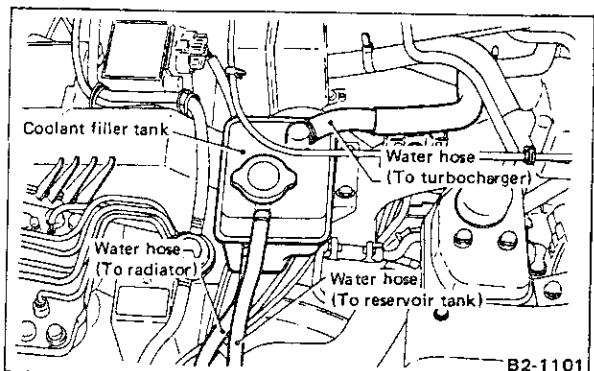
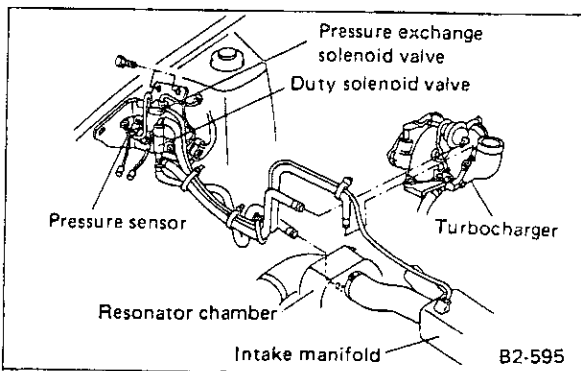
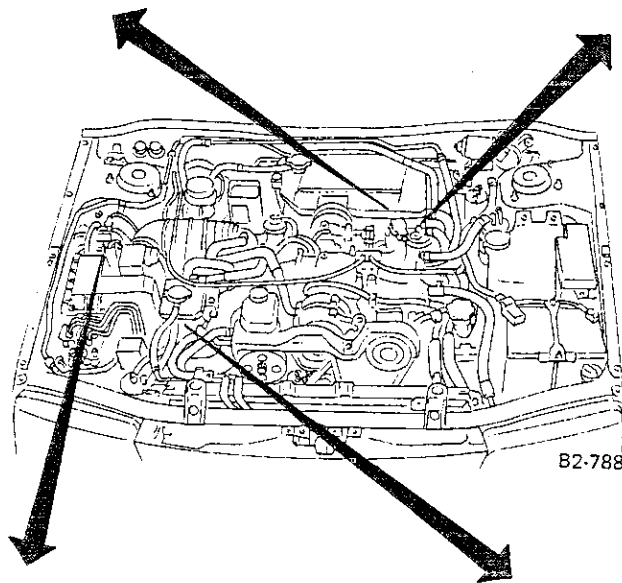
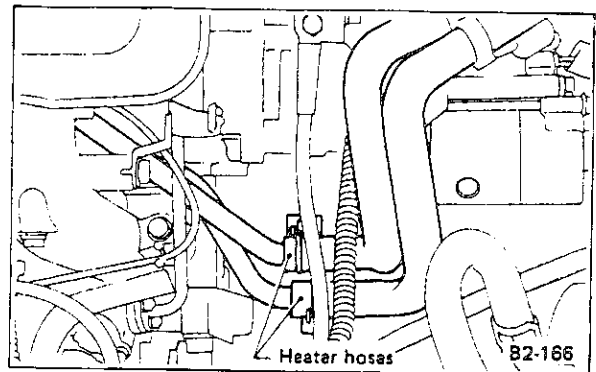
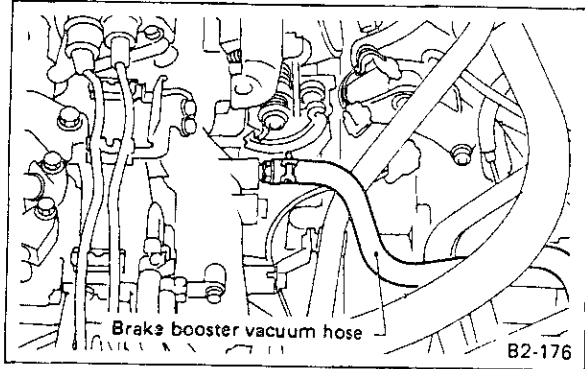


Fig. 17

B2-780

14) Remove power steering pump from bracket.

- (1) Loosen lock bolt and slider bolt, and remove front side V-belt.
- (2) Disconnect right side spark plug cords, and remove pipe with bracket from intake manifold.

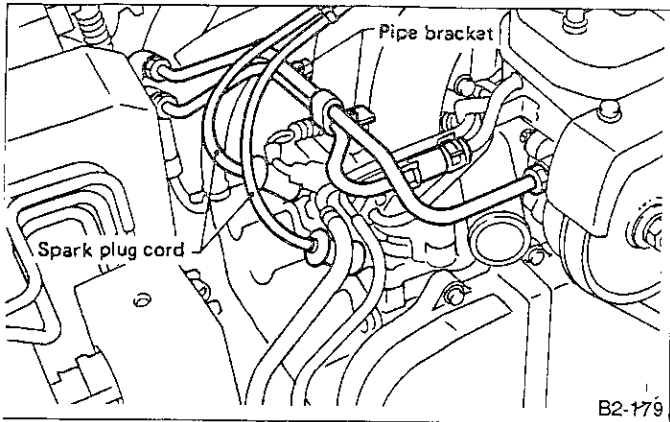


Fig. 18

- (3) Remove bolt which installs power steering pump from bracket.

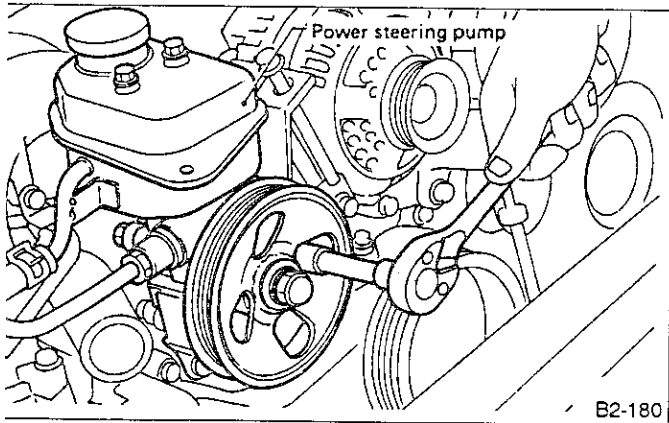


Fig. 19

- (4) Place power steering pump on the right side wheel apron.

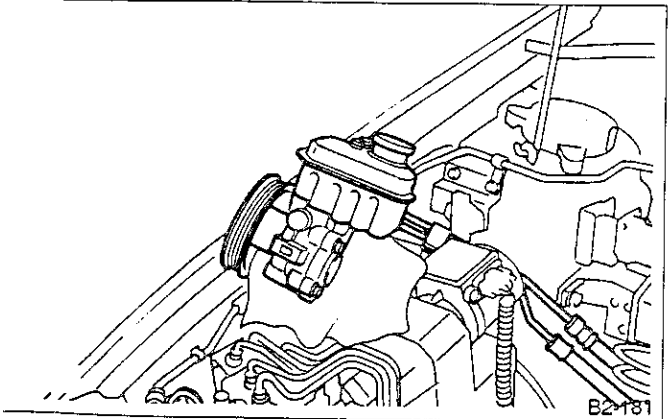


Fig. 20

15) Separate center exhaust pipe from turbocharger unit. [Turbo]

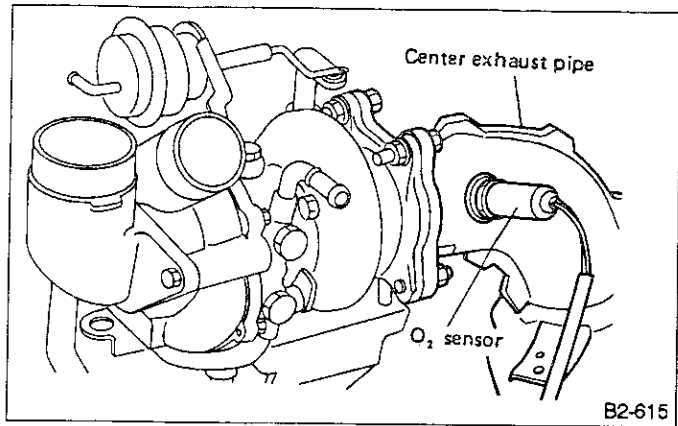


Fig. 21

16) Remove exhaust system.

- (1) Lift up the vehicle.
- (2) Remove nuts which install front exhaust pipe onto engine. [Non-Turbo]
- (3) Separate front exhaust pipe (center exhaust pipe on turbo model) from rear exhaust pipe.

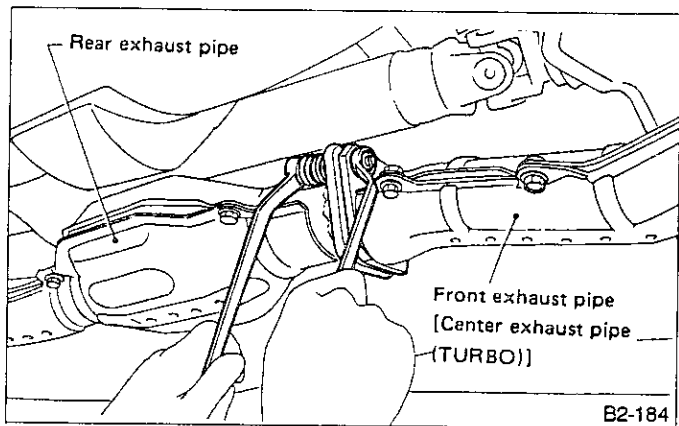


Fig. 22

- (4) Remove turbocharger lower cover.

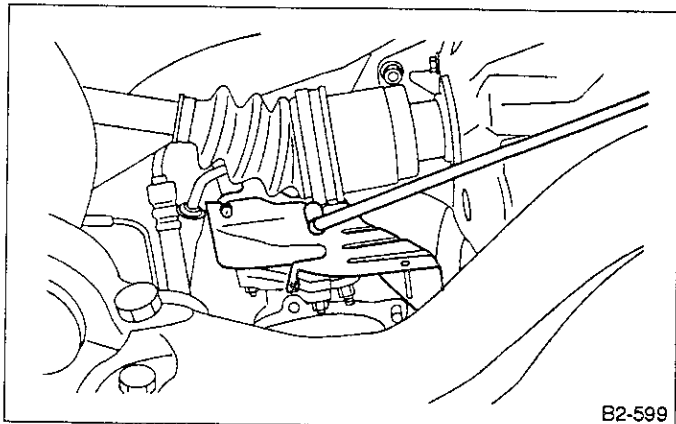


Fig. 23

(5) Remove front exhaust pipe (center exhaust pipe on turbo model).

Exhaust pipe will drop when all bolts are removed. So, hold it when removing the last bolt.

17) Remove nut which installs lower side of starter.

18) Remove nuts which hold lower side of transmission to engine.

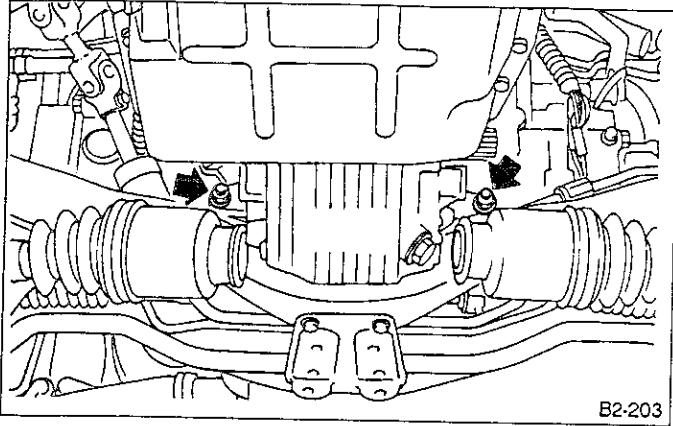


Fig. 24

19) Remove nuts which install front cushion rubber onto front crossmember.

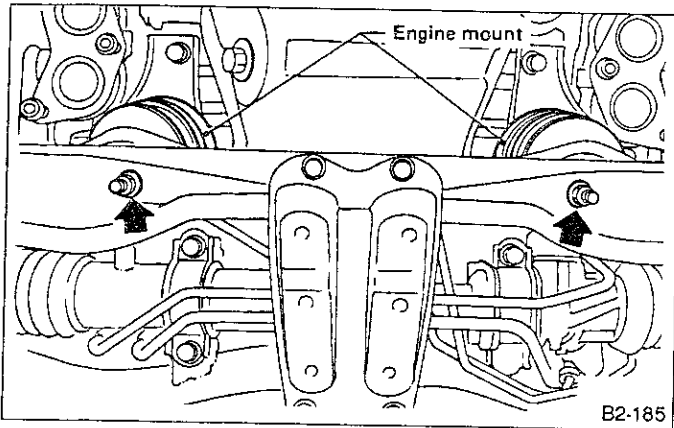


Fig. 25

20) Remove starter.

(1) Lower the vehicle.

(2) Disconnect connectors and terminal from starter.

(3) Remove bolt which installs upper side of starter, and remove starter.

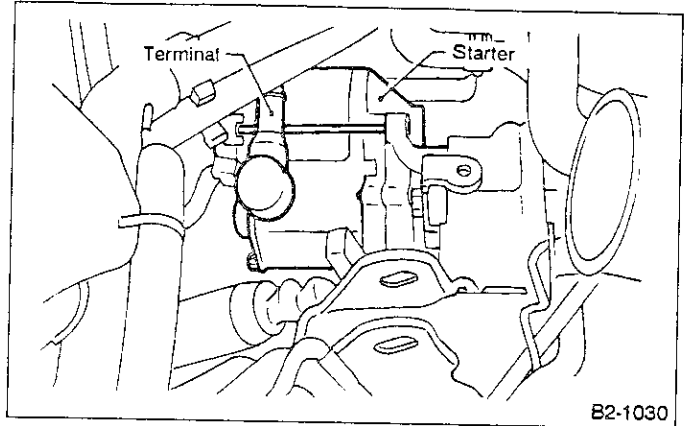


Fig. 26

21) Separate clutch release fork from release bearing. [Turbo]

(1) Remove clutch operating cylinder from transmission.

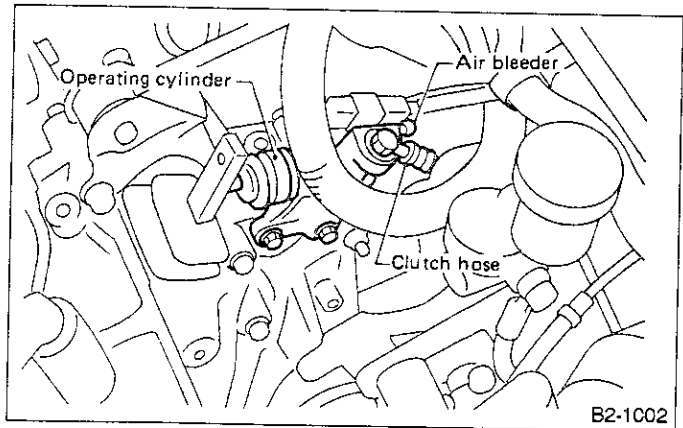


Fig. 27

(2) Remove plug using 10-mm HEX. wrench.

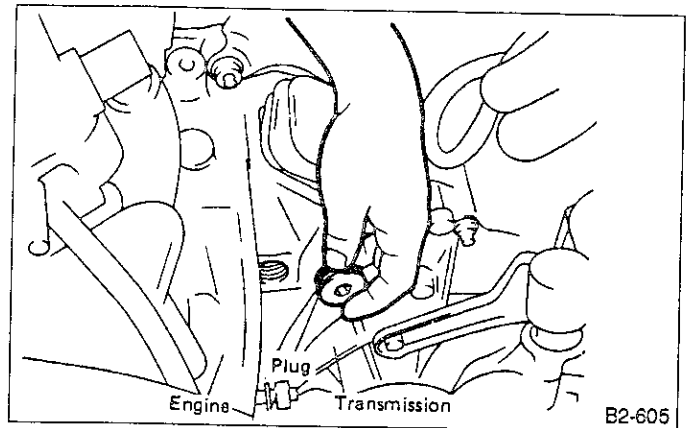


Fig. 28

(3) Screw 6-mm dia. bolt into release fork shaft, and remove it.

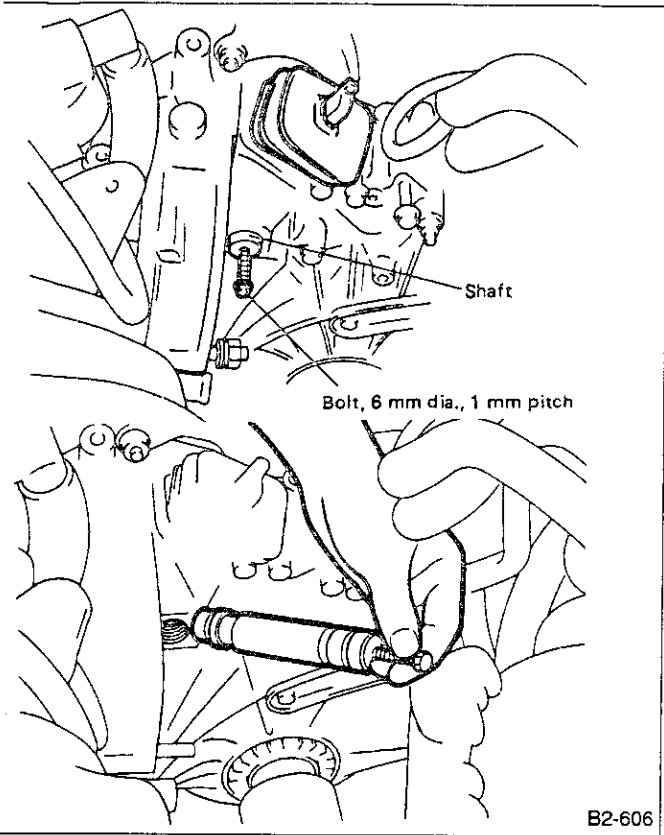


Fig. 29

(4) Raise release fork and unfasten release bearing tabs to free release fork.

Step (4) is required to prevent interference with engine when removing engine from transmission.

22) Separate torque converter from drive plate. [AT]

- (1) Remove service hole plug.
- (2) Remove bolts which hold torque converter to drive plate.
- (3) Remove other bolts while rotating the engine.

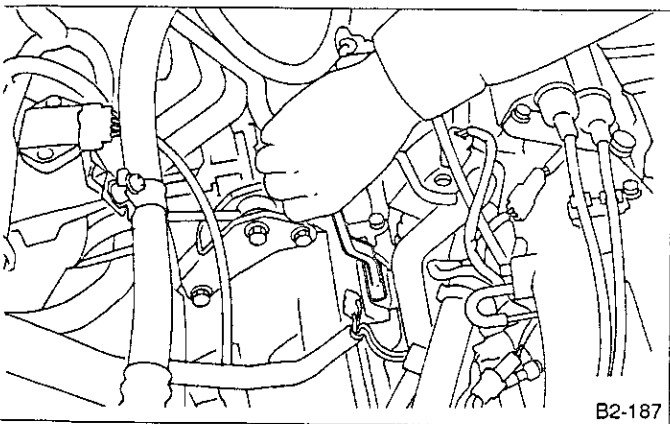


Fig. 30

23) Remove pitching stopper.

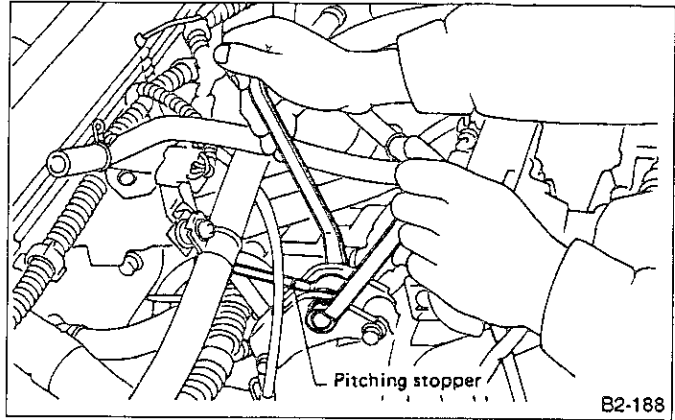


Fig. 31

24) Disconnect fuel delivery hose, return hose and evaporation hose.

Catch fuel from hose into container.

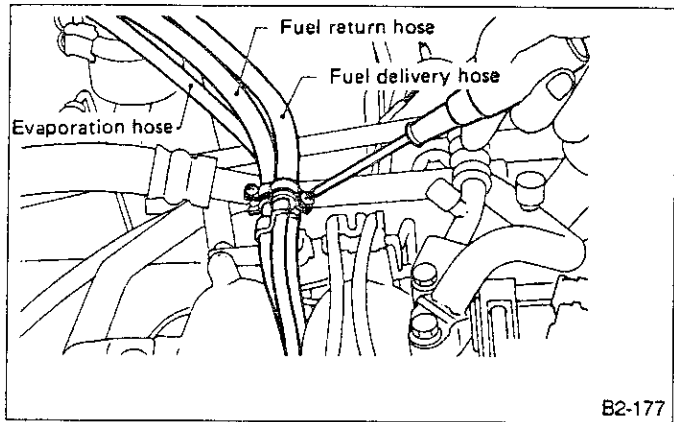


Fig. 32

25) Support engine with a lifting device and wire ropes.

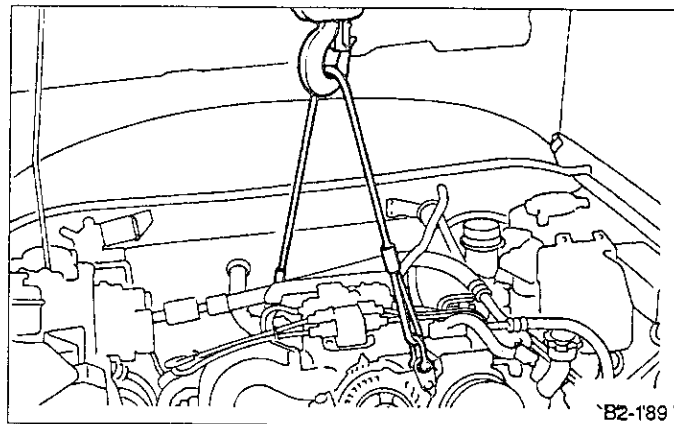


Fig. 33

26) Support transmission with a garage jack.

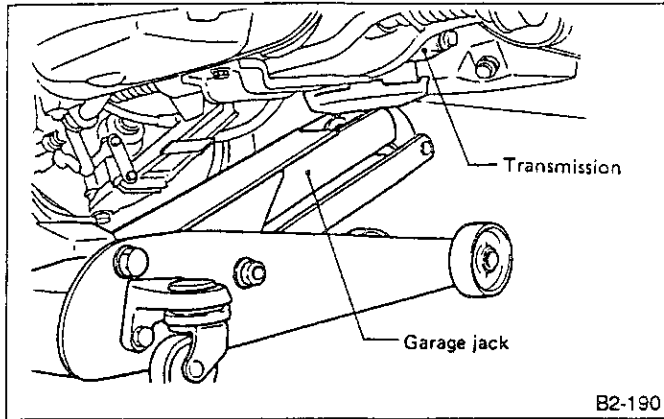


Fig. 34

Before moving engine away from transmission, check to be sure no work has been overlooked. Doing this is very important in order to facilitate re-installation and because transmission lowers under its own weight.

27) Remove bolt which holds upper side of transmission to engine.

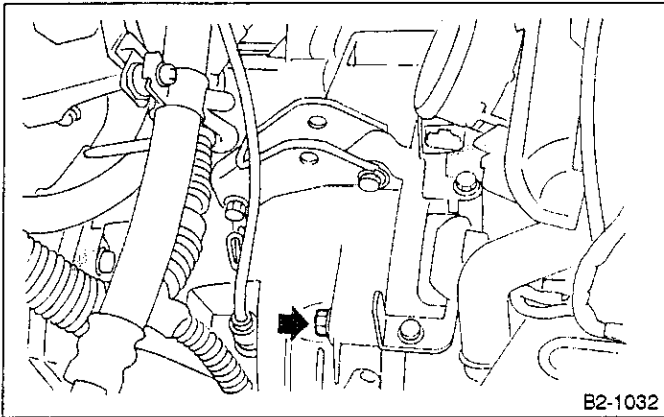


Fig. 35

28) Remove engine from vehicle.

- (1) Slightly raise engine.
- (2) Raise transmission with garage jack.
- (3) Move engine horizontally until mainshaft is withdrawn from clutch cover.
- (4) Slowly move engine away from engine compartment.

Be careful not to damage adjacent parts or body panels with crank pulley, oil pressure gauge, etc.

B: INSTALLATION

Turbo model

1. Install clutch release fork and bearing onto transmission.

2. Install engine to transmission.

3. Tighten bolt which holds right upper side of transmission to engine.

4. Remove lifting device and wire rope.
5. Remove garage jack.

6. Install pitching stopper.

Turbo model

7. Install clutch operating cylinder.

AT model

8. Install torque converter onto drive plate.

9. Install canister and bracket.
10. Install power steering pump on bracket.

11. Install starter.

12. Tighten nuts which hold lower side of transmission to engine.
13. Tighten nuts which install front cushion rubber onto cross-member.

14. Install exhaust system.
• Front exhaust pipe [Non-Turbo]
• Center exhaust pipe [Turbo]
• Turbocharger lower cover [Turbo]

Turbo model

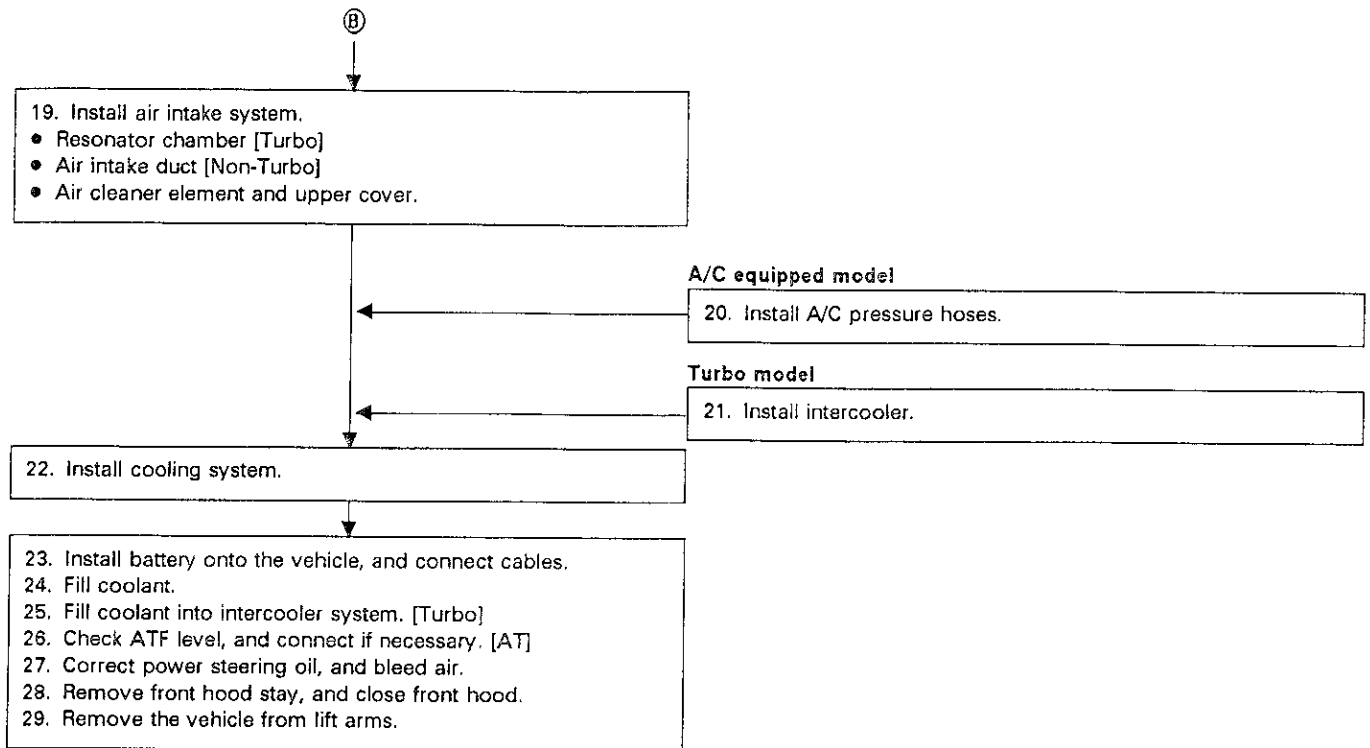
15. Install center exhaust pipe onto turbocharger unit.
16. Install air inlet duct.

17. Connect hoses, connectors and cables.

Turbo model

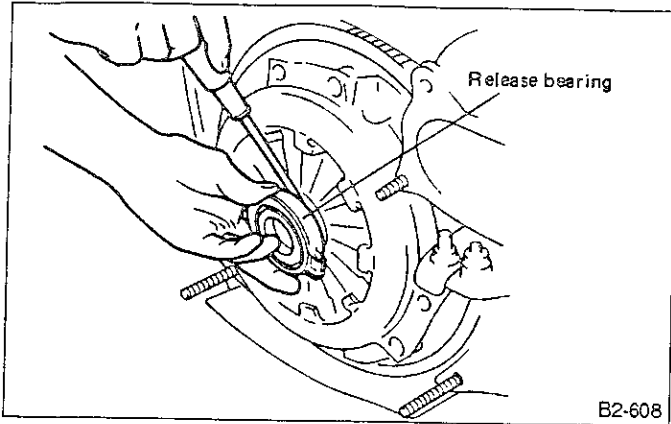
18. Install turbocharger cooling duct.

Ⓑ



1) Install clutch release fork and bearing onto transmission. [Turbo]

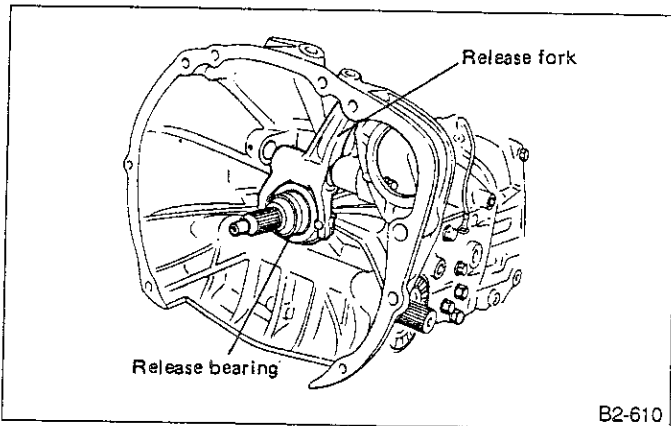
(1) Remove release bearing from clutch cover with flat type screw driver. [Turbo]



B2-608

Fig. 36

(2) Install release bearing on transmission.
 (3) Insert release fork into release bearing tab.

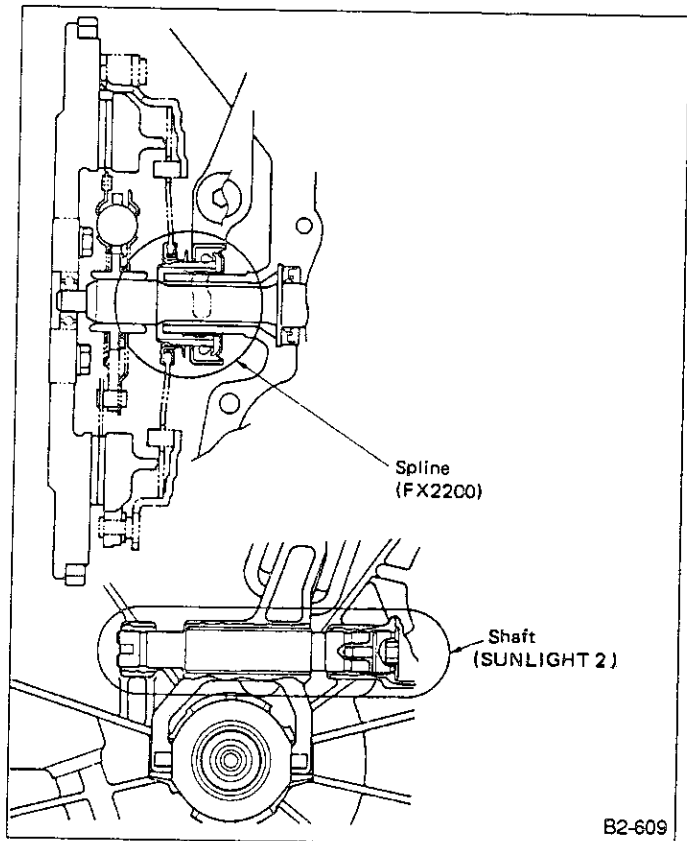


B2-610

Fig. 37

(4) Apply grease to specified points:

- Splines Fx2200
- Shaft SUNLIGHT 2

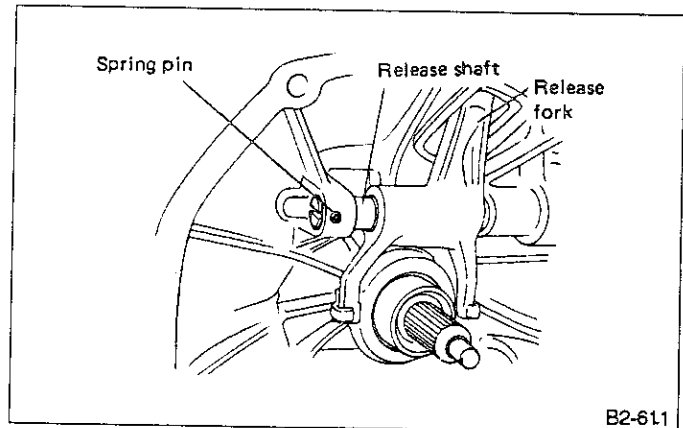


B2-609

Fig. 38

(5) Insert release fork shaft into release fork.

Make sure the cutout portion of release fork shaft contacts spring pin.



B2-611

Fig. 39

(6) Tighten plug.

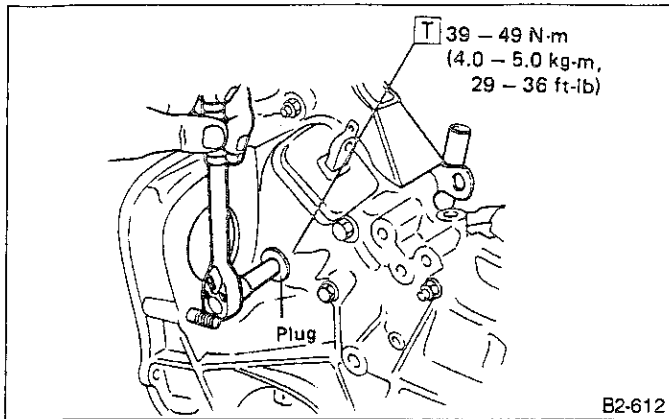


Fig. 40

2) Install engine onto transmission.

(1) Position engine in engine compartment and align it with transmission.

Be careful not to damage adjacent parts or body panels with crank pulley, oil pressure gauge, etc.

(2) Apply a small amount of grease to splines of mainshaft.

(3) Push clutch release fork, and assemble release bearing in clutch cover.

Refer to C. 2-10 [W3C0].



Fig. 41

3) Tighten bolt which holds right upper side of transmission to engine.

Tightening torque: N·m (kg-m, ft-lb)
46 - 54 (4.7 - 5.5, 34 - 40)

- 4) Remove lifting device and wire ropes.
- 5) Remove garage jack.
- 6) Install pitching stopper.

Tightening torque: N·m (kg-m, ft-lb)

To body side

47 - 67 (4.8 - 6.8, 35 - 49)

To bracket side

44 - 54 (4.5 - 5.5, 33 - 40)

7) Install clutch operating cylinder. [Turbo]

Tightening torque: N·m (kg-m, ft-lb)

34 - 40 (3.5 - 4.1, 25 - 30)

8) Install torque converter onto drive plate. [AT]

(1) Tighten bolts which hold torque converter to drive plate.

(2) Tighten other bolts while rotating the engine.

Be careful not to drop bolts into torque converter housing.

Tightening torque: N·m (kg-m, ft-lb)

23 - 26 (2.3 - 2.7, 17 - 20)

(3) Clog plug onto service hole.

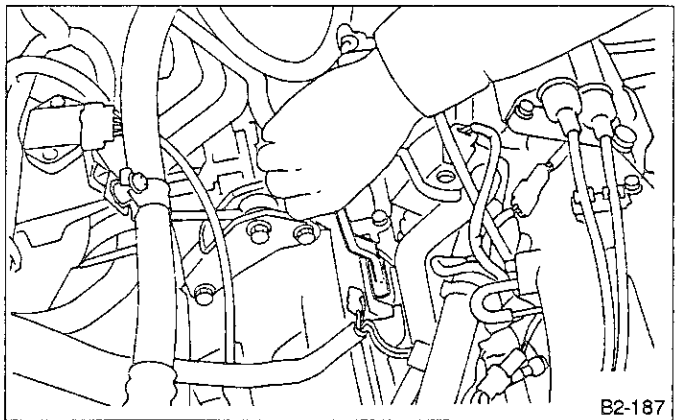


Fig. 42

9) Install canister and bracket.

10) Install power steering pump on bracket.

(1) Install power steering pump on bracket, and tighten bolts.

Tightening torque: N·m (kg-m, ft-lb)

29 - 49 (3 - 5, 22 - 36)

- (2) Install power steering pipe bracket on right side intake manifold, and install spark plug codes.
- (3) Install front side V-belt, and adjust it.

Refer to C. 1-5 [W1A0] for adjustment of V-belt.

11) Install starter.

(1) Connect connectors and terminal, and install starter onto transmission case.

- (2) Tighten bolt which installs upper side of starter.
- (3) Lift up the vehicle.
- (4) Tighten nut which installs lower side of starter.

Tightening torque: N·m (kg-m, ft-lb)
29 — 49 (3 — 5, 22 — 36)

- 12) Tighten nuts which hold lower side of transmission to engine.

Tightening torque: N·m (kg-m, ft-lb)
46 — 54 (4.7 — 5.5, 34 — 40)

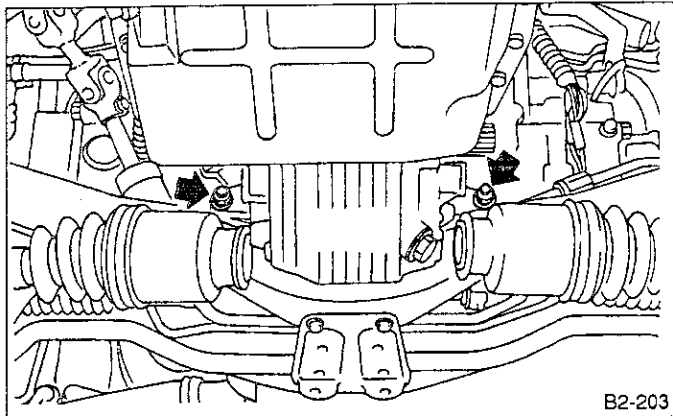


Fig. 43

- 13) Tighten nuts which install front cushion rubber onto crossmember.

Tightening torque: N·m (kg-m, ft-lb)
54 — 83 (5.5 — 8.5, 40 — 61)

- a. Be sure to tighten front cushion rubber mounting bolts in the innermost elliptical hole in the front crossmember.

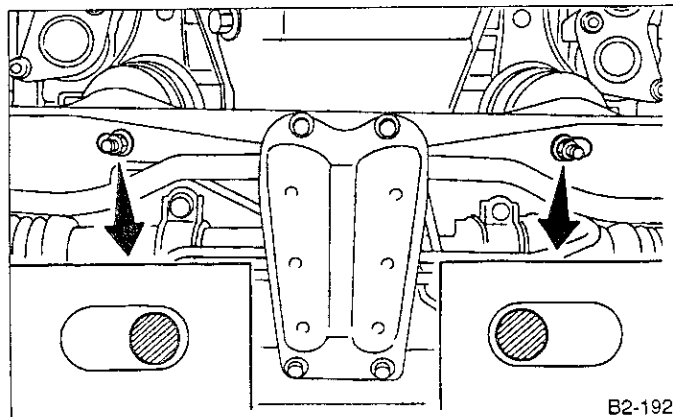


Fig. 44

- b. Ensure clearance "H" is in specified range.

Clearance H:
4 — 6 mm (0.16 — 0.24 in)

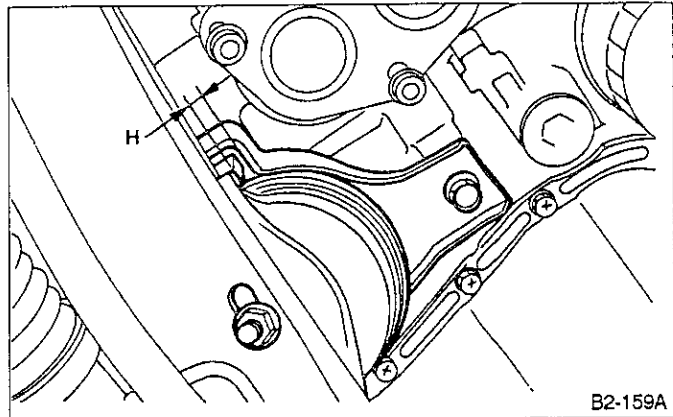


Fig. 45

- 14) Install exhaust system.

- (1) Non-Turbo model

Tightening torque: N·m (kg-m, ft-lb)

Front exhaust pipe to engine

25 — 34 (2.5 — 3.5, 18 — 25)

Front exhaust pipe onto hanger hinge

30 — 40 (3.1 — 4.1, 22 — 30)

Front exhaust pipe to rear exhaust pipe

13 — 23 (1.3 — 2.3, 9 — 17)

- (2) Turbo model

Tightening torque: N·m (kg-m, ft-lb)

Center exhaust pipe onto hanger hinge

30 — 40 (3.1 — 4.1, 22 — 30)

Center exhaust pipe to rear exhaust pipe

13 — 23 (1.3 — 2.3, 9 — 17)

- (3) Install turbocharger lower cover. [Turbo]

- 15) Install center exhaust pipe to turbocharger unit. [Turbo]

- (1) Lower the vehicle.

- (2) Tighten nut which installs center exhaust pipe to turbocharger unit.

Tightening torque: N·m (kg-m, ft-lb)

25 — 34 (2.5 — 3.5, 18 — 25)

- 16) Install air inlet duct. [Turbo]

17) Connect hoses, connectors and cables.

(1) Connect the following hoses.

- Fuel delivery hose, return hose and evaporation hose
- Heater inlet and outlet hoses
- Brake booster vacuum hose
- Canister hoses
- Coolant filler tank hose [Turbo]
- Turbocharging pressure control vacuum hose [Turbo]

(2) Connect the following connectors.

- Engine ground terminal
- Engine harness connectors
- O₂ sensor connector
- Air flow sensor connector
- Knock sensor connector
- Cam angle sensor connector
- Crank angle sensor connector
- Alternator connector and terminal
- A/C compressor connectors [A/C equipped model]

(3) Connect the following cables.

- Accelerator cable
- Cruise control cables [Cruise control equipped model]
- Hill-holder cable [Non-Turbo MT]
- Clutch cable [Non-Turbo MT]
- Clutch release spring

After connecting each cable, adjust them.

18) Install turbocharger cooling duct. [Turbo]

19) Install air intake system.

- (1) Install air intake duct. [Non-Turbo]
- (2) Install resonator chamber. [Turbo]
- (3) Install air cleaner element and upper cover.

20) Install A/C pressure hoses. [A/C equipped model]

Refer to C. 4-7.

Tightening torque: N·m (kg-m, ft-lb)

18 — 31 (1.8 — 3.2, 13 — 23)

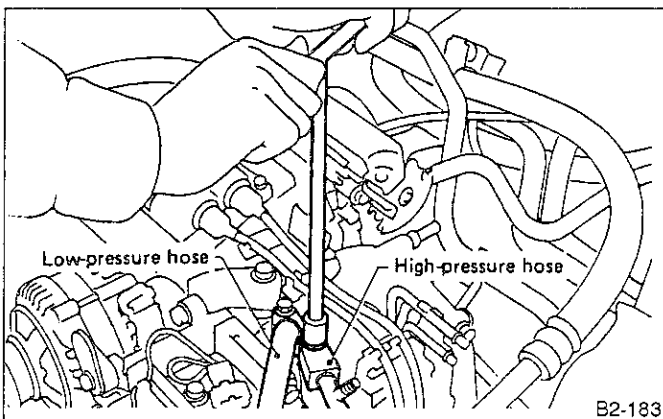


Fig. 46

21) Install intercooler.

- (1) Install intercooler on bracket.
- (2) Connect throttle body to intercooler, and connect air outlet duct to turbocharger unit.
- (3) Connect water hoses to pipes.

22) Install cooling system.

- (1) Attach radiator mounting cushions to pins on lower side of radiator.
- (2) Fit cushions on lower side of radiator, into holes on body side and install radiator.

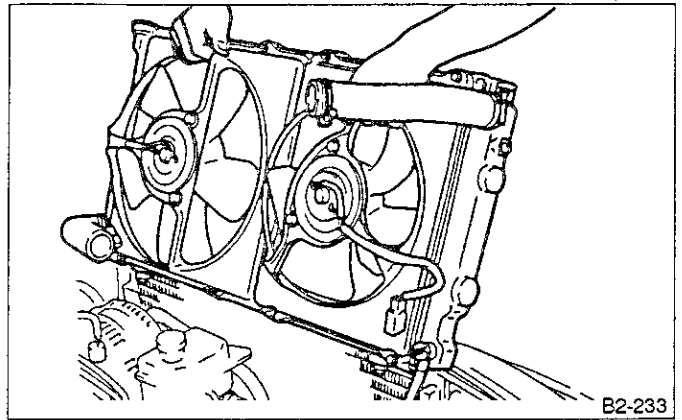


Fig. 47

- (3) Install radiator brackets and tighten bolts.

Tightening torque: N·m (kg-m, ft-lb)

12.3 — 15.2 (1.25 — 1.55, 9.0 — 11.2)

- (4) Connect radiator fan motor connector.
- (5) Connect radiator inlet and outlet hoses.
- (6) Connect ATF cooler hoses. [AT]
- (7) Connect coolant filler tank hose. [Turbo]
- (8) Install reservoir tank and overflow hose.
- (9) Install V-belt cover.

23) Install battery in the vehicle, and connect cables.

24) Fill coolant.

Refer to C. 1-5 [W8B0].

25) Fill coolant into intercooler system. [Turbo]

Refer to C. 2-7.

26) Check ATF level and correct if necessary. [AT]

Refer to C. 1-5 [W110].

27) Charge A/C system with refrigerant.

Refer to C. 4-7 [W700].

28) Remove front hood stay, and close front hood.

29) Remove the vehicle from lift arms.

3. Transmission

A: REMOVAL

1. Open front hood fully, and support it with stay.
2. Disconnect battery ground terminal.

Turbo model

3. Remove intercooler.

4. Remove air intake system.
 - Air intake duct [Non-Turbo]
 - Resonator chamber [Turbo]
 - Air inlet duct [Turbo]

Turbo model

5. Remove turbocharger cooling duct.

6. Disconnect connectors and cables.

7. Remove starter.

8. Remove pitching stopper and bracket.

Turbo model

9. Separate clutch release fork from release bearing.

AT model

10. Separate torque converter from drive plate.

11. Remove transmission oil level gauge.

AT model

12. Remove front differential oil level gauge.

13. Remove transmission connector bracket.

14. Set special tools.

15. Remove bolt which holds right upper side of transmission to engine.

16. Remove exhaust system.
 - Front exhaust pipe [Non-Turbo]
 - Turbocharger lower cover [Turbo]
 - Center exhaust pipe [Turbo]
 - Rear exhaust pipe [4WD]

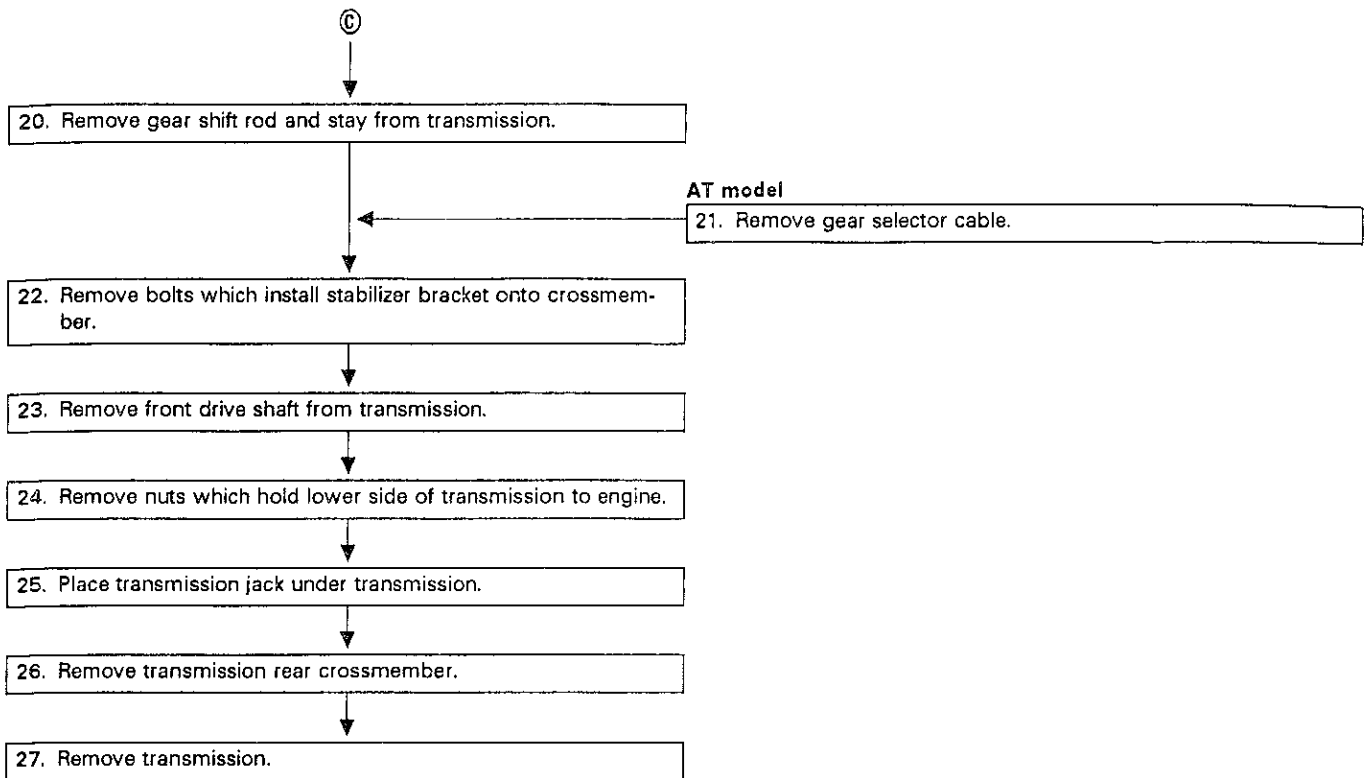
AT model

17. Drain ATF to remove drain plug.
18. Disconnect ATF cooler hose from pipe on transmission side, and remove ATF supply pipe.

4WD model

19. Remove propeller shaft.

©



- 1) Open front hood fully, and support with stay.
- 2) Disconnect battery ground terminal.
- 3) Remove intercooler. [Turbo]
 - (1) Separate intercooler from throttle body.
 - (2) Separate air outlet duct from turbocharger unit.
 - (3) Remove intercooler from bracket.
 - (4) Place intercooler on the left side wheel apron.

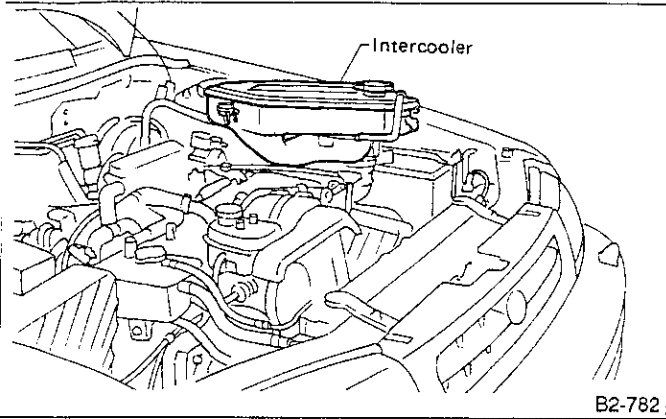


Fig. 48

- 4) Remove air intake system.

- (1) Remove air intake duct. [Non-Turbo]

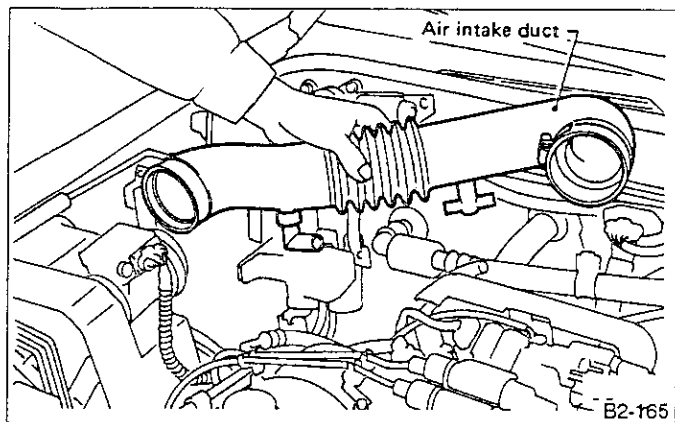


Fig. 49

- (2) Remove resonator chamber. [Turbo]

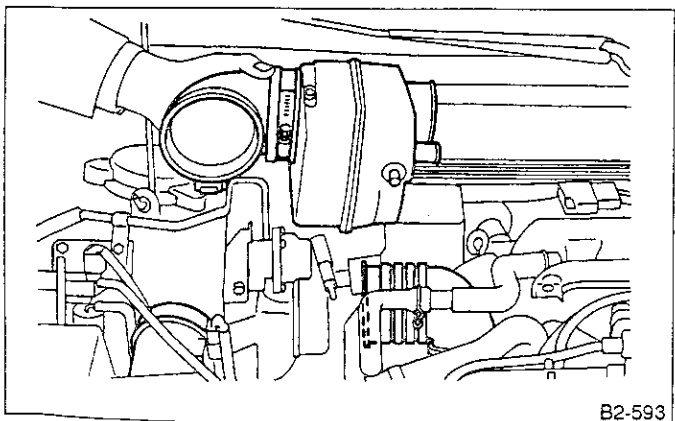


Fig. 50

- (3) Remove air inlet duct. [Turbo]

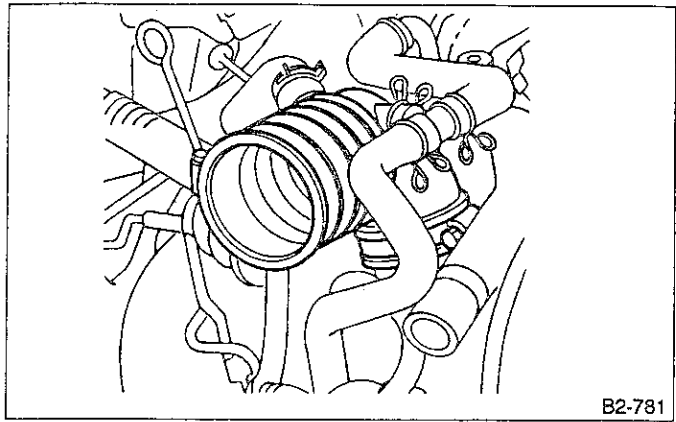


Fig. 51

- 5) Remove turbocharger cooling duct. [Turbo]

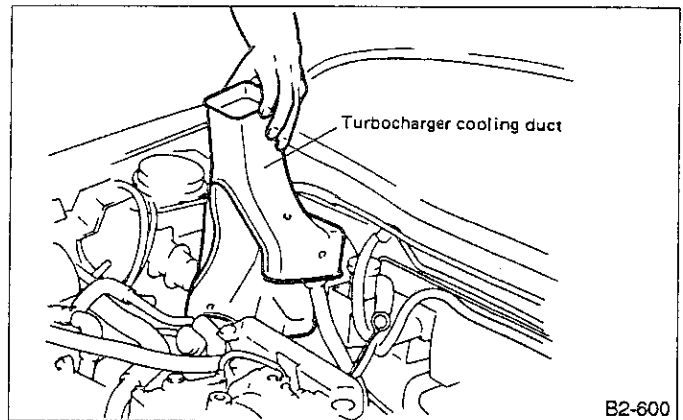


Fig. 52

- 6) Disconnect connectors and cables.

- (1) Disconnect the following connectors.

- O₂ sensor
- Vehicle speed sensor 2 [Turbo]
- Transmission harness connector
- Transmission ground terminal

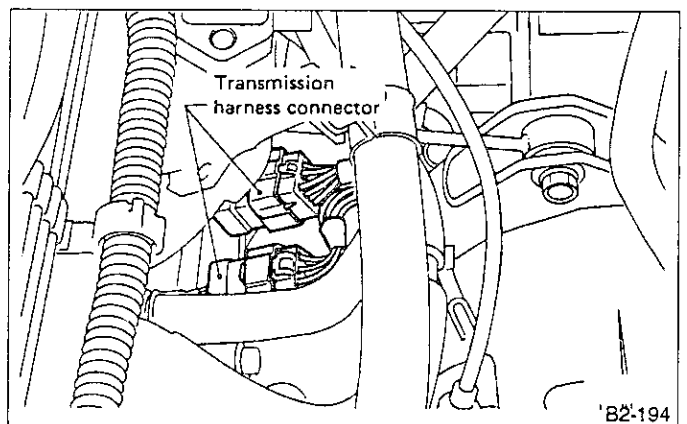


Fig. 53

(2) Disconnect the following cables.

- Clutch release spring [MT]
- Clutch cable [Non-Turbo MT]
- Hill-holder cable [Non-Turbo MT]
- Speedometer cable [Non-Turbo]

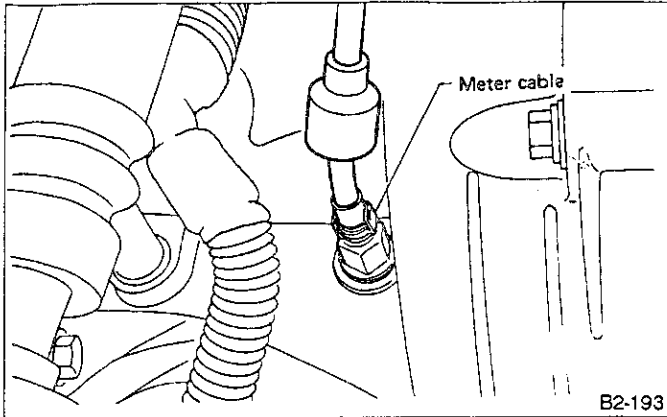


Fig. 54

7) Remove starter.

- (1) Disconnect connectors and terminal from starter.
- (2) Remove bolt which installs upper side of starter.
- (3) Remove nut which installs lower side of starter, and remove starter from transmission.

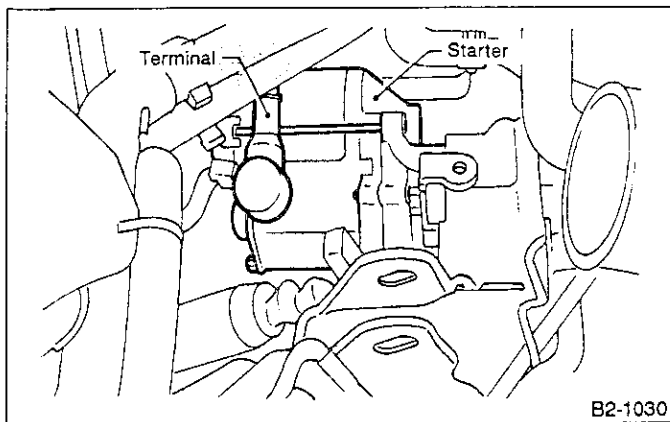


Fig. 55

8) Remove pitching stopper and bracket.

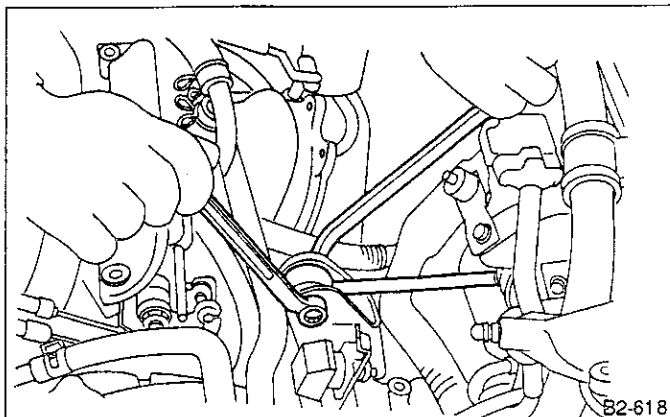


Fig. 56

9) Separate clutch release fork from release bearing. [Turbo]

- (1) Remove clutch operating cylinder from transmission case.

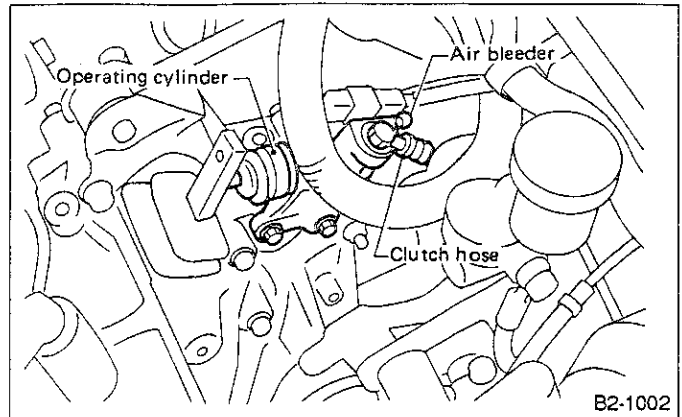


Fig. 57

- (2) Remove plug using 10-mm HEX. wrench.

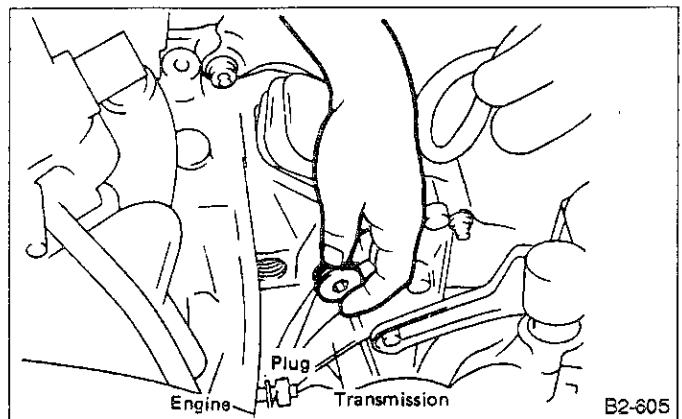


Fig. 58

- (3) Screw 6-mm bolt into bolt hole of release fork shaft, and drive out release fork shaft.
- (4) Raise release fork to separate from release bearing tabs.

Refer to C. 2-10 [W101].

- 10) Separate torque converter from drive plate. [AT]
 (1) Remove service hole plug.
 (2) Remove bolts which hold torque converter to drive plate.

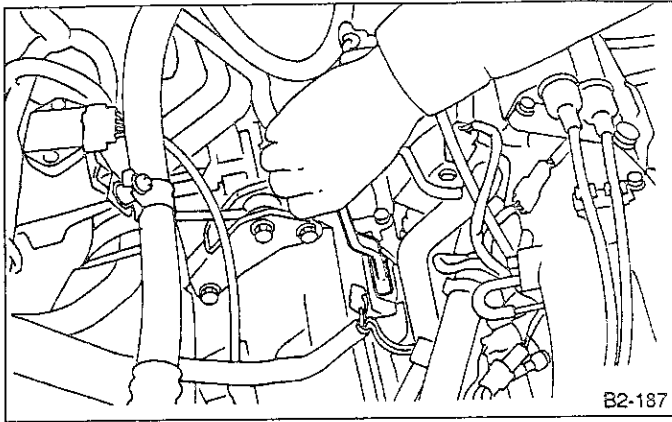


Fig. 59

- (3) While rotating the engine, remove other bolts.
 Be careful not to drop bolts into torque converter housing.

- 11) Remove transmission oil level gauge. [MT]
 12) Remove front differential oil level gauge. [AT]
 Plug opening to prevent entry of foreign particles into transmission fluid.
 13) Remove transmission connector bracket.

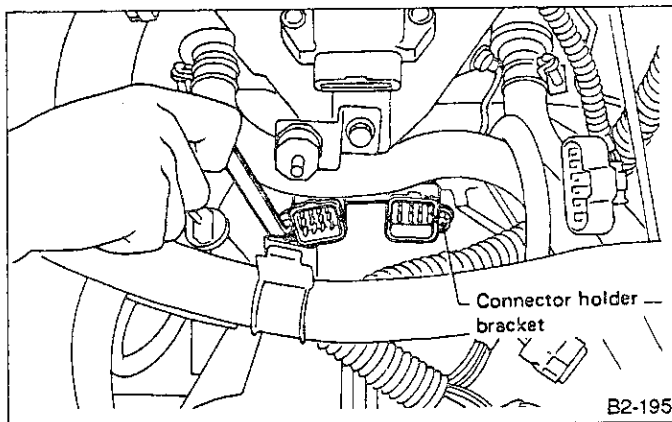


Fig. 60

- 14) Set special tools.

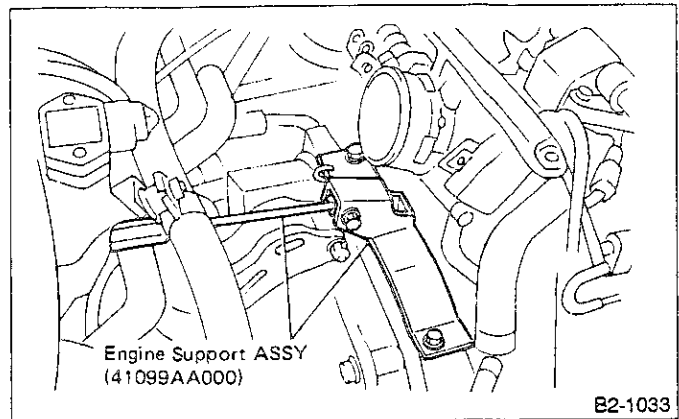


Fig. 61

Also available is P/N 927670000.

- 15) Remove bolt which holds right upper side of transmission to engine.

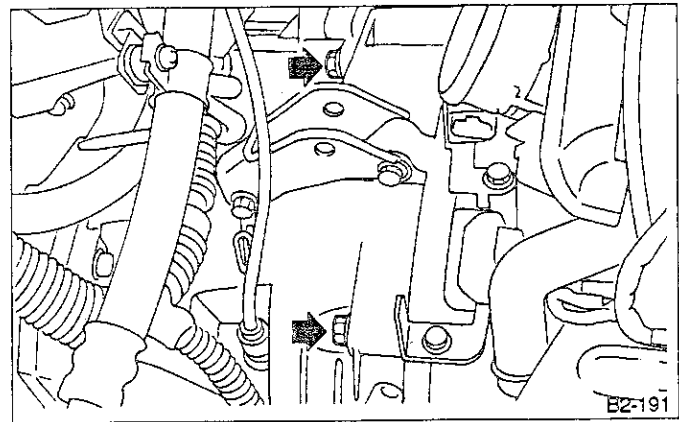


Fig. 62

- 16) Remove exhaust system.

- (1) Separate center exhaust pipe from turbocharger unit. [Turbo]

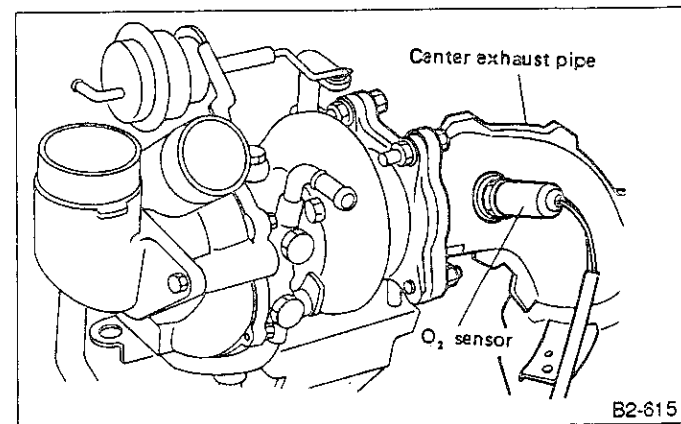


Fig. 63

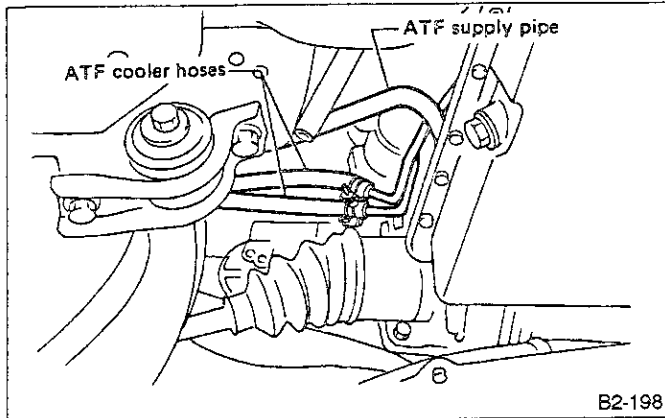
- (2) Lift up the vehicle.
- (3) Remove front exhaust pipe. [Non-Turbo]
- (4) Remove turbocharger lower cover. [Turbo]
- (5) Remove center exhaust pipe. [Turbo]
- (6) Remove rear exhaust pipe. [4WD]

a. When removing exhaust pipes, be careful each exhaust pipe does not drop out.

b. Refer to C. 2-9 [W201], [W203].

17) Drain ATF to remove drain plug. [AT]

18) Disconnect ATF cooler hose from pipe of transmission side and ATF supply pipe. [AT]



B2-198

Fig. 64

19) Remove propeller shaft. [4WD]

- (1) Remove front cover of rear differential mount.
- (2) Separate propeller shaft from rear differential.
- (3) Remove bolts which hold center bearing onto body.

Be careful not to drop propeller shaft.

(4) Remove propeller shaft from transmission.

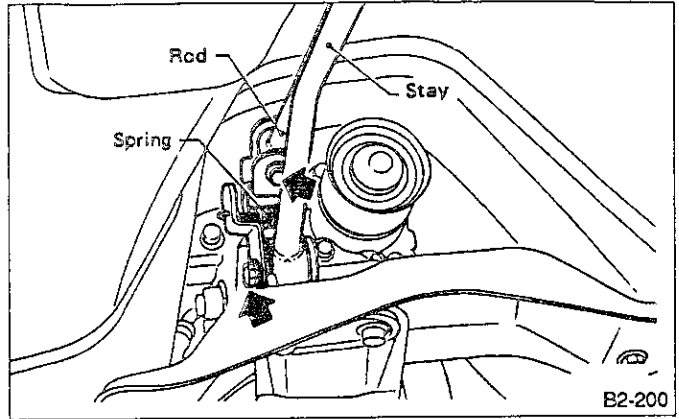
a. Be sure to use an empty container to catch oil flowing out when removing propeller shaft.

b. Be sure not to damage oil seals and the frictional surface of sleeve yoke.

c. Be sure to plug the opening in transmission after removal of propeller shaft.

20) Remove gear shift rod and stay from transmission. [MT]

- (1) Remove spring.
- (2) Disconnect stay CP from transmission.
- (3) Disconnect rod CP from transmission.

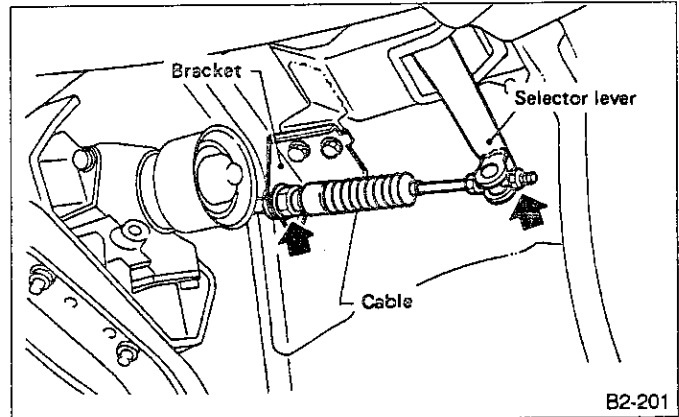


B2-200

Fig. 65

21) Remove gear selector cable.

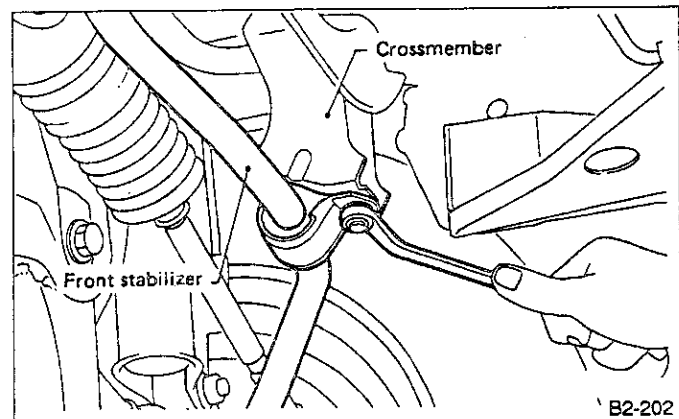
- (1) Disconnect gear selector cable from selector lever.
- (2) Remove cable bracket from selector lever ASSY.



B2-201

Fig. 66

22) Remove bolts which install stabilizer clamp onto crossmember.

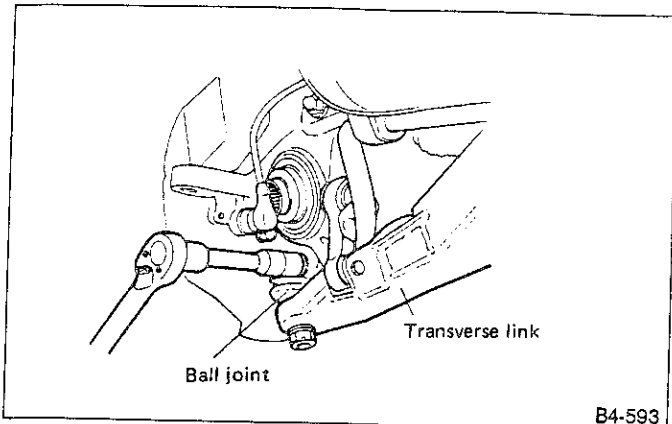


B2-202

Fig. 67

23) Remove front drive shaft from transmission.

- (1) Remove transverse link from housing.



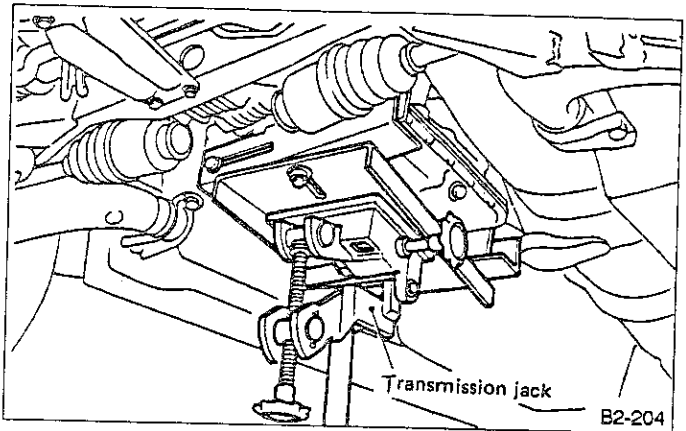
B4-593

Fig. 68

- (2) Lower transverse link.
- (3) Remove spring pin and separate front drive shaft from each side of the transmission.

Discard removing spring pin. Replace with a new one.

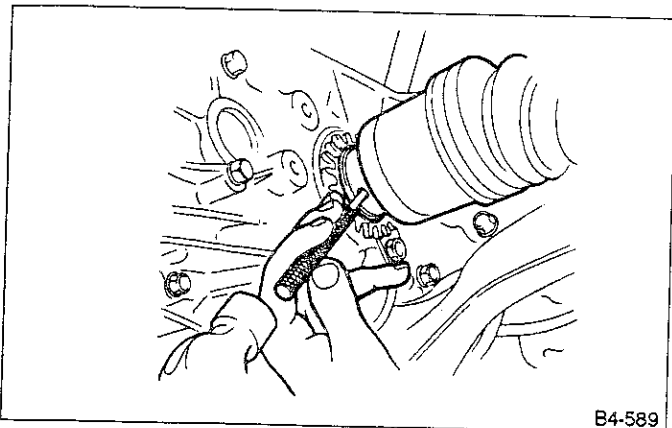
Always support transmission case with a transmission jack.



B2-204

Fig. 71

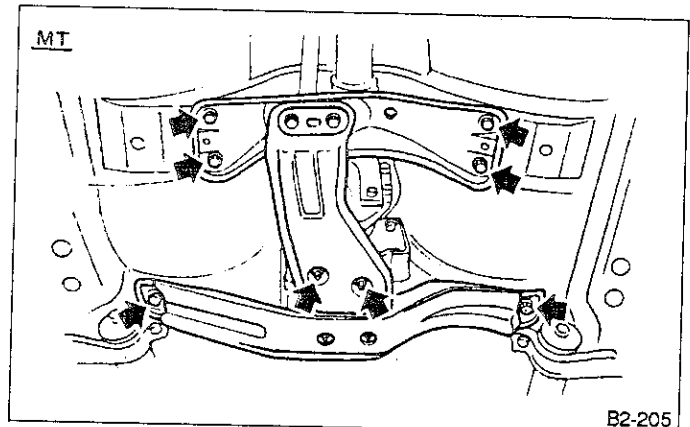
- 26) Remove transmission rear crossmember.



B4-589

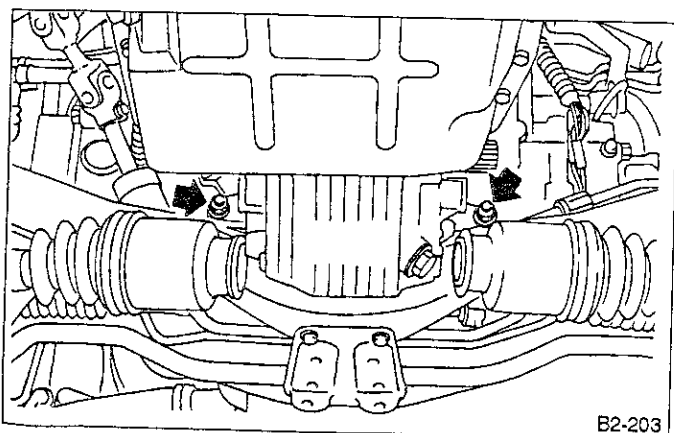
Fig. 69

- 24) Remove nuts which hold lower side of transmission to engine.



B2-205

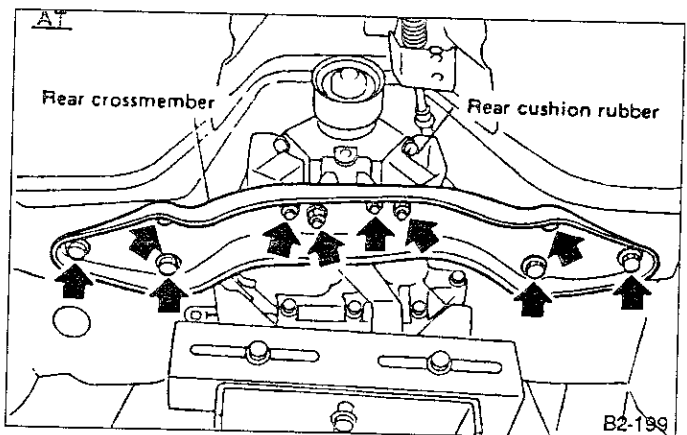
Fig. 72



B2-203

Fig. 70

- 25) Place transmission jack under transmission.



B2-199

Fig. 73

- 27) Remove transmission.

- a. Move transmission jack toward rear until mainshaft is withdrawn from clutch cover. [MT]
- b. Move transmission and torque converter as a unit away from engine. [AT]

B: INSTALLATION**Turbo model**

1. Install clutch release fork and bearing to transmission.



2. Install transmission to engine.



3. Install transmission rear crossmember.



4. Take off transmission jack.



5. Tighten nuts which hold lower side of transmission to engine.

**Turbo model**

6. Assemble clutch release bearing into clutch cover to push clutch release fork.



7. Tighten bolt which holds right upper side of transmission to engine.

**AT model**

8. Install torque converter to drive plate.



9. Remove special tools.
10. Install pitching stopper and bracket.

**Turbo model**

11. Install clutch operating cylinder.



12. Install front drive shaft into transmission.



13. Install stabilizer bracket onto front crossmember.



14. Install gear shift rod and stay.



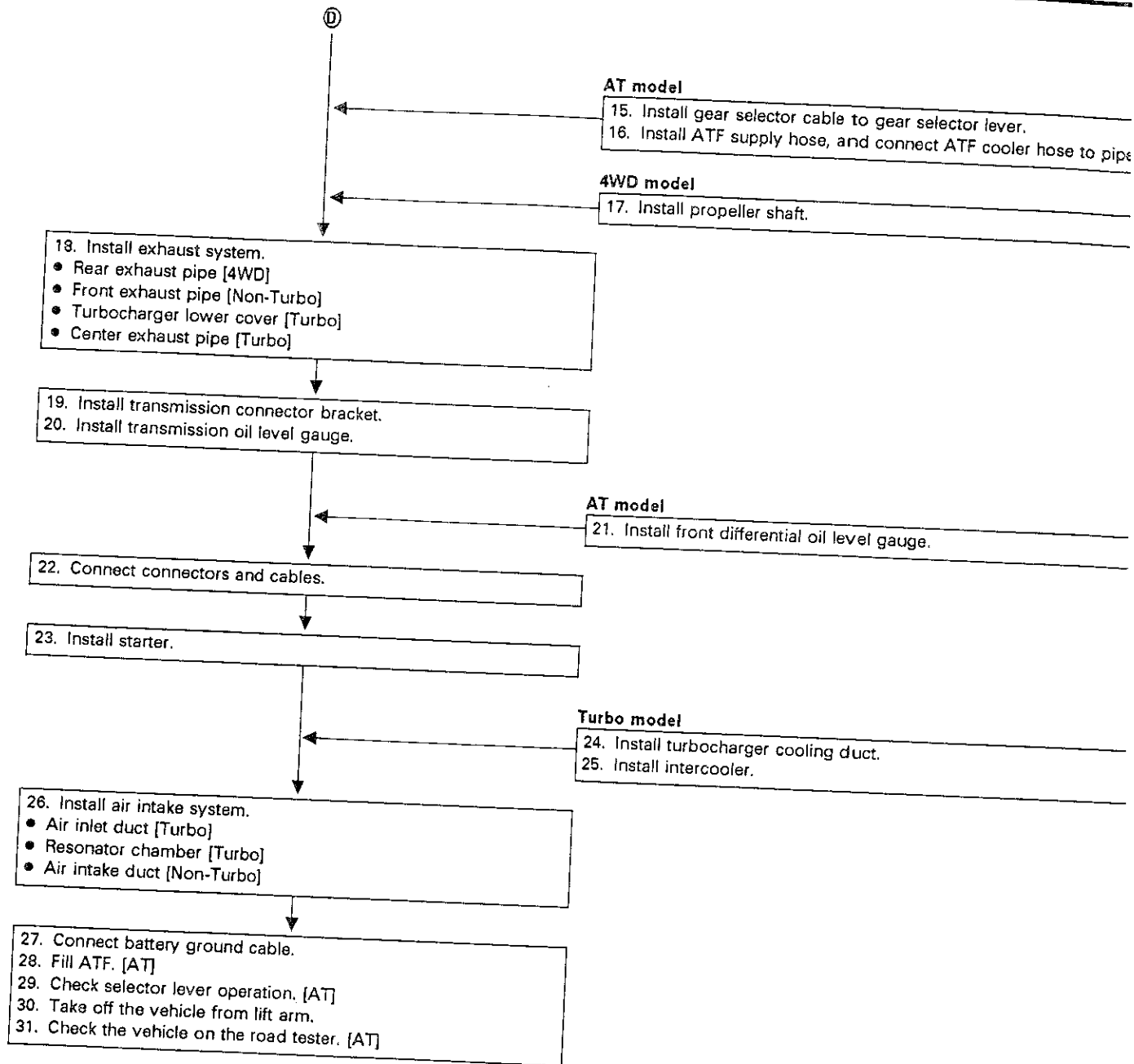
⑩

2-11 [

Fig. 6
(2)
(3)
from
Discar

Fig.
24)
sion

Fig.
25)



1) Install clutch release fork and bearing onto transmission. [Turbo]

(1) Remove release bearing from clutch cover with flat type screwdriver.

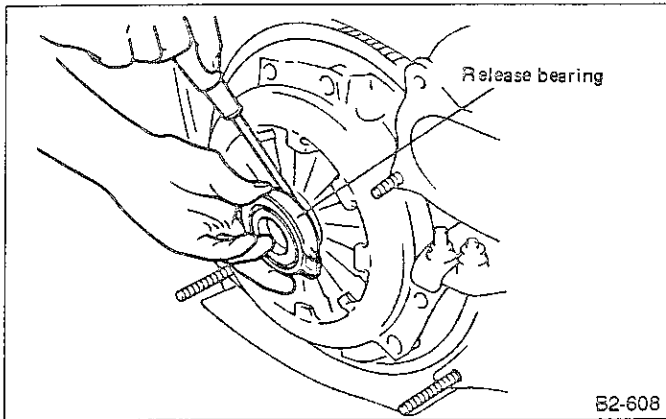


Fig. 74

(2) Install release bearing onto transmission.
 (3) Insert release fork into release bearing tab.

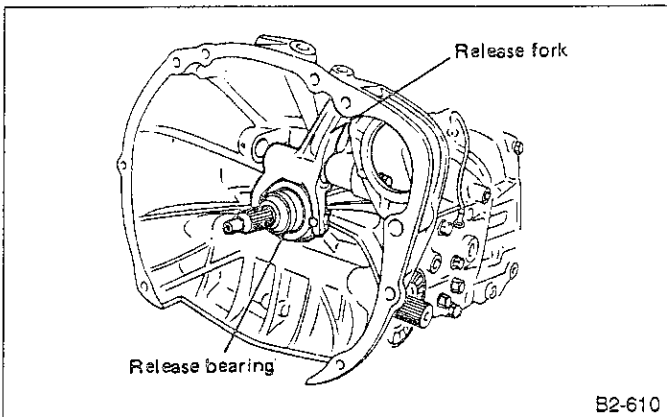


Fig. 75

(4) Apply grease to specified points:

- Splines Fx2200
- Shaft SUNLIGHT 2

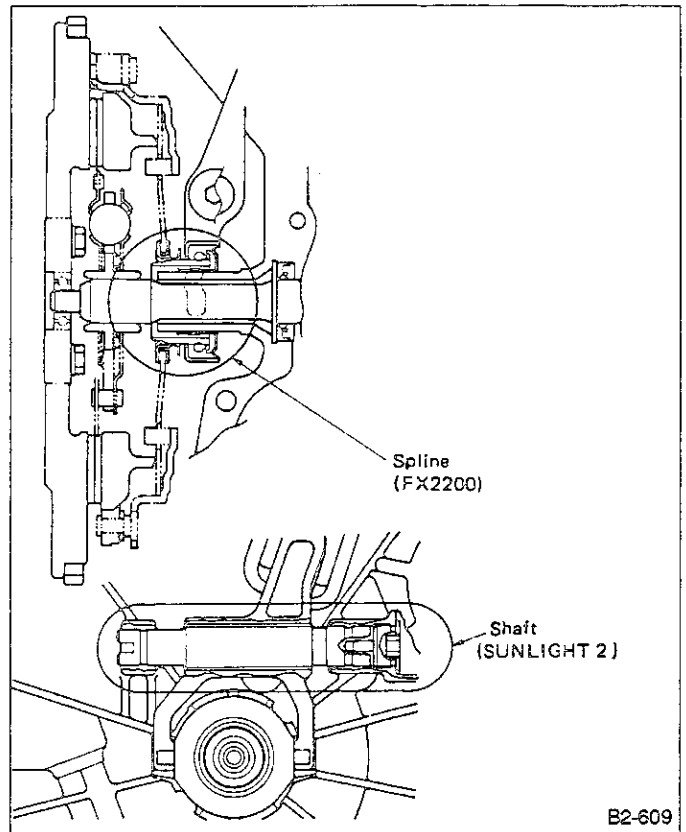


Fig. 76

(5) Insert release fork shaft into release fork.
 Make sure the cutout portion of release fork shaft contacts spring pin.

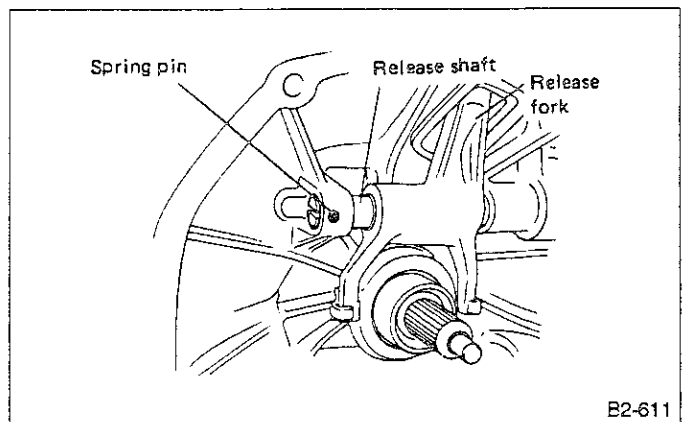


Fig. 77

(6) Install plug.

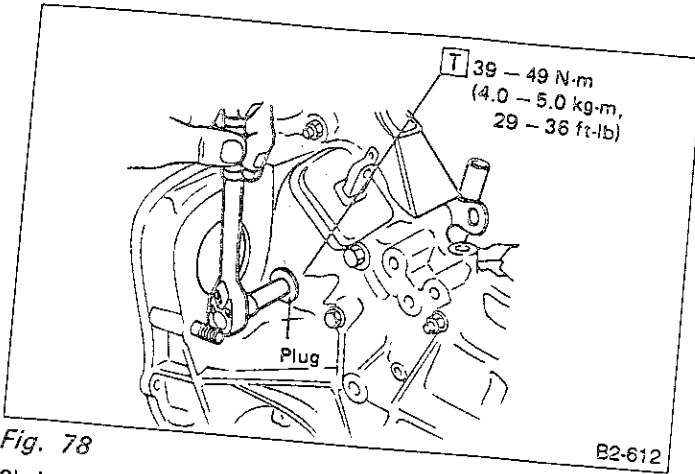


Fig. 78

B2-612

Tightening torque: N·m (kg·m, ft·lb)
 T1: 27 - 47 (2.8 - 4.8, 20 - 35)
 T2: 118 - 157 (12 - 16, 87 - 116)
 T3: 54 - 83 (5.5 - 8.5, 40 - 61)
 T4: 13 - 23 (1.3 - 2.3, 9 - 17)

- 4) Take off transmission jack.
- 5) Tighten nuts which hold lower side of transmission to engine.

Tightening torque: N·m (kg·m, ft·lb)
 46 - 54 (4.7 - 5.5, 34 - 40)

- 2) Install transmission onto engine.
 - (1) Gradually raise transmission with transmission jack.
 - (2) Engage them at splines.

Be careful not to strike mainshaft against clutch cover.
 [MT]

- 3) Install transmission rear crossmember.

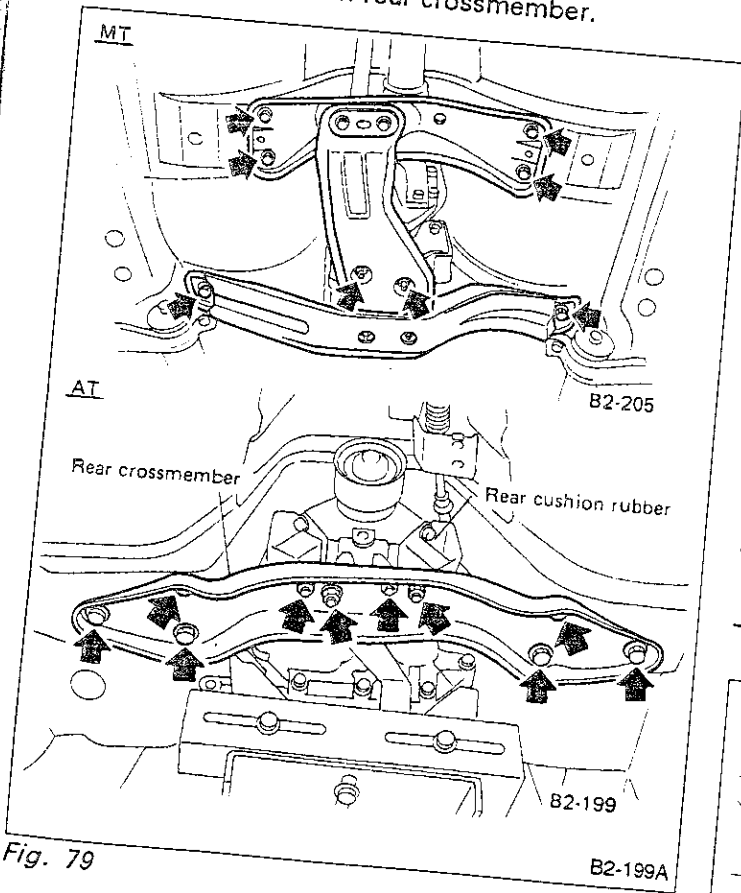


Fig. 79

B2-199A

- 6) Assemble clutch release bearing into clutch cover. [Turbo]

- (1) Lower the vehicle.
- (2) Push release fork, and assemble release bearing into clutch cover.

Refer to C. 2-10 [W3C0].

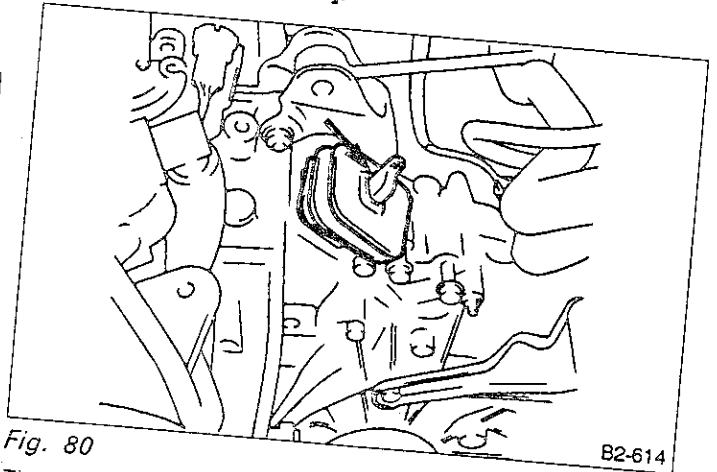


Fig. 80

B2-614

- 7) Tighten bolt which holds right upper side of transmission to engine.

Tightening torque: N·m (kg·m, ft·lb)
 46 - 54 (4.7 - 5.5, 34 - 40)

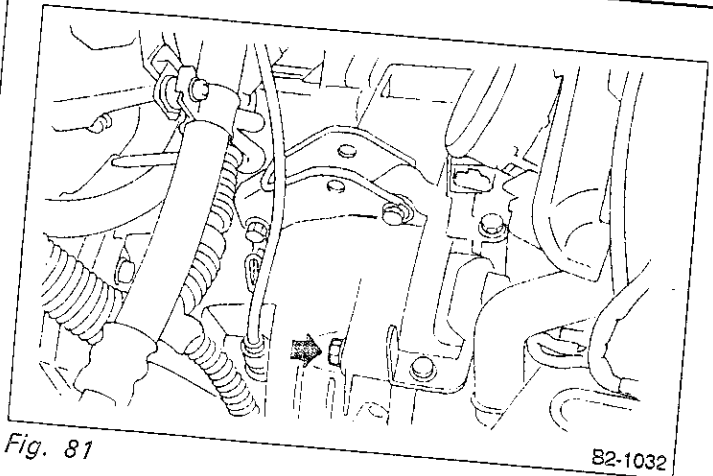


Fig. 81

B2-1032

- 8) Install torque converter to drive plate. [AT]
- (1) Tighten bolts which hold torque converter to drive plate.
 - (2) While rotating the engine, tighten other bolts.
- Be careful not to drop bolts into torque converter housing.

Tightening torque: N·m (kg-m, ft-lb)
23 — 26 (2.3 — 2.7, 17 — 20)

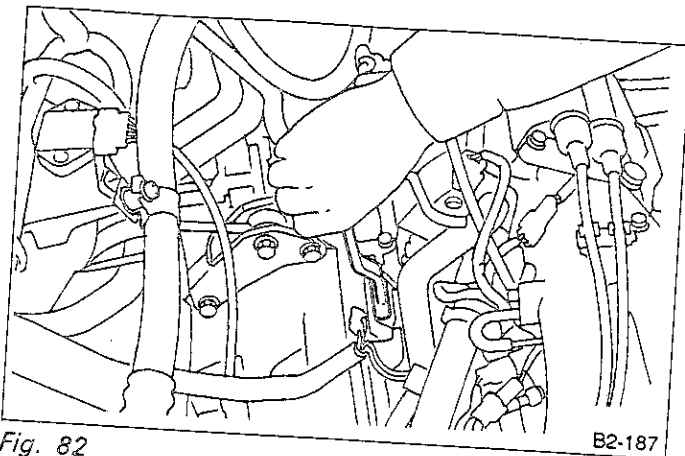


Fig. 82

B2-187

- (3) Clog plug onto service hole.
 - (4) Install V-belt cover.
- 9) Remove special tools.

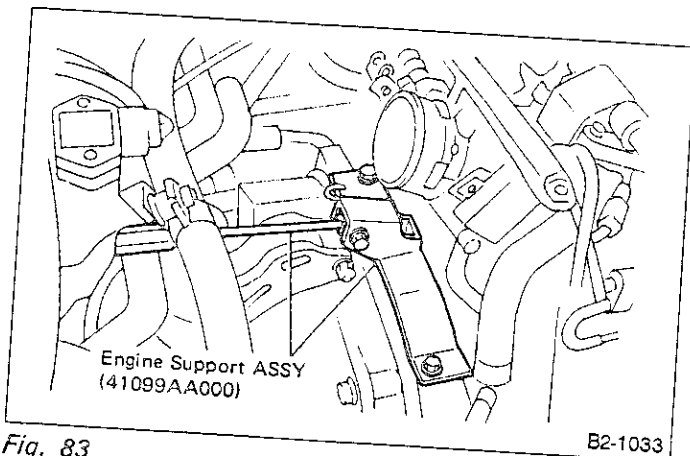


Fig. 83

B2-1033

- 10) Install pitching stopper and bracket.
- (1) Install pitching stopper bracket on transmission.
 - (2) Install pitching stopper.

Tightening torque: N·m (kg-m, ft-lb)

To body side	47 — 67 (4.8 — 6.8, 35 — 49)
To bracket side	44 — 54 (4.5 — 5.5, 33 — 40)

- 11) Install clutch operating cylinder. [Turbo]

Tightening torque: N·m (kg-m, ft-lb)
34 — 40 (3.5 — 4.1, 25 — 30)

- 12) Install front drive shaft into transmission.
- (1) Lift up the vehicle.
 - (2) Install front drive shaft into transmission.
 - (3) Drive spring pin into chamfered hole of drive shaft.

Always use a new spring pin.

- (4) Install ball joint of lower arm into knuckle arm of housing, and tighten installing bolt.

Tightening torque: N·m (kg-m, ft-lb)
25 — 29 (2.5 — 3.0, 18 — 22)

- 13) Install stabilizer clamp onto front crossmember.

Tightening torque: N·m (kg-m, ft-lb)
21 — 28 (2.1 — 2.9, 15 — 21)

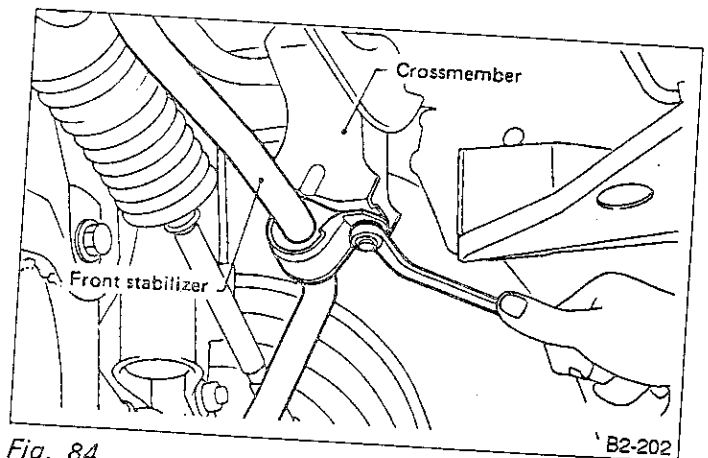


Fig. 84

B2-202

- 14) Install gear shift rod and stay. [MT]
- (1) Install gear shift rod onto transmission.
 - (2) Install stay onto transmission.
 - (3) Install spring.
- 15) Install gear selector cable onto selector cable. [AT]
- (1) Install selector cable into selector lever.
 - (2) Install cable bracket onto selector lever ASSY.

Tightening torque: N·m (kg-m, ft-lb)
13 — 23 (1.3 — 2.3, 9 — 17)

Tighten selector cable adjusting and lock nut after checking selector lever operation [step. 31]].

Tightening torque: N·m (kg-m, ft-lb)
18 — 31 (1.8 — 3.2, 13 — 23)

16) Install ATF supply hose, and ATF cooler hose onto pipe. [AT]

17) Install propeller shaft. [4WD]

- (1) Install propeller shaft into transmission.
- (2) Tighten bolts which install propeller shaft onto companion flange of rear differential.

Tightening torque: N·m (kg-m, ft-lb)
24 — 39 (2.4 — 4.0, 17 — 29)

(3) Install center bearing bracket on body.

Tightening torque: N·m (kg-m, ft-lb)
47 — 57 (4.8 — 5.8, 35 — 42)

18) Install exhaust system.

(1) Install rear exhaust pipe to muffler. [4WD]

Tightening torque: N·m (kg-m, ft-lb)
43 — 53 (4.4 — 5.4, 32 — 39)

(2) Install turbocharger lower cover. [Turbo]

(3) Install front exhaust pipe. [Non-Turbo]

Tightening torque: N·m (kg-m, ft-lb)

To engine

25 — 34 (2.5 — 3.5, 18 — 25)

To hanger bracket

30 — 40 (3.1 — 4.1, 22 — 30)

To rear exhaust pipe

13 — 23 (1.3 — 2.3, 9 — 17)

(4) Install center exhaust pipe. [Turbo]

Tightening torque: N·m (kg-m, ft-lb)

To hanger bracket

30 — 40 (3.1 — 4.1, 22 — 30)

To rear exhaust pipe

13 — 23 (1.3 — 2.3, 9 — 17)

To turbocharger unit

25 — 35 (2.5 — 3.6, 18 — 26)

19) Install transmission connector bracket.

20) Install transmission oil level gauge. [MT]

21) Install front differential oil level gauge. [AT]

22) Connect connectors and cables.

(1) Connect the following connectors.

- Transmission harness connectors
- Transmission ground terminal
- O₂ sensor connector
- Crank angle sensor connector
- Cam angle sensor connector
- Knock sensor connector

(2) Connect the following cables.

- Accelerator cable
- Cruise control cable
- Clutch cable [Non-Turbo MT]
- Hill-holder cable [Non-Turbo MT]

23) Install starter.

(1) Install starter onto transmission case, and connect connectors and terminals.

(2) Tighten bolt and nut which install starter onto transmission.

Tightening torque: N·m (kg-m, ft-lb)
46 — 54 (4.7 — 5.5, 34 — 40)

24) Install turbocharger cooling duct. [Turbo]

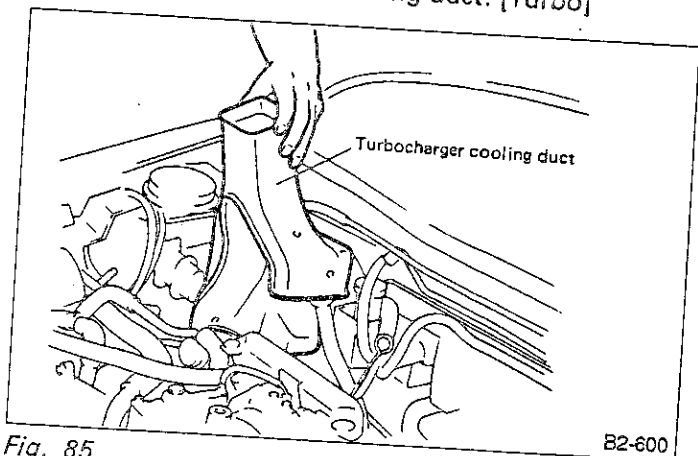


Fig. 85

25) Install intercooler. [Turbo]

(1) Install intercooler on bracket.

(2) Connect intercooler to throttle body, and connect air outlet duct to turbocharger unit.

26) Install air intake system.

(1) Install air intake duct. [Non-Turbo]

(2) Install air inlet and outlet duct. [Turbo]

(3) Install resonator chamber. [Turbo]

27) Connect battery ground cable.

28) Fill ATF. [AT]

Refer to C. 1-5.

29) Check selector lever operation. [AT]

Refer to C. 3-3.

30) Take off vehicle from lift arms.

31) Check the vehicle on road tester. [AT]

Refer to C. 3-2.



Publication No. G205AE ②
Issued: September 1991 A
Printed in Japan M-0.25



SUBARU[®]

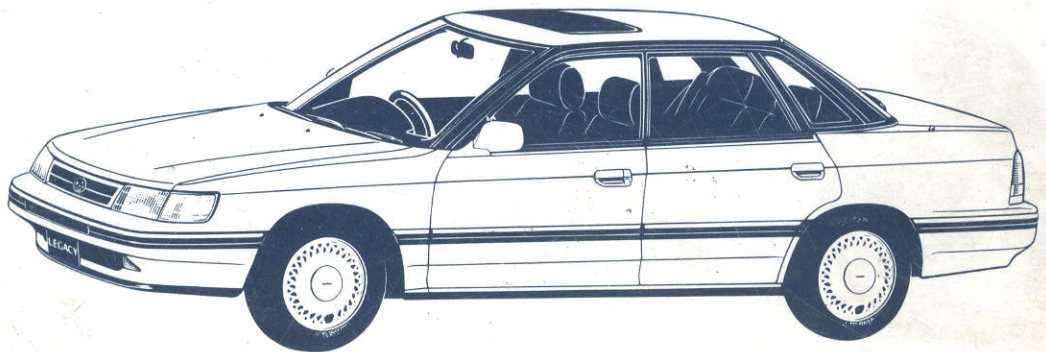
LIBERTY

1992

SERVICE

MANUAL

SECTION 6



SUBARU®**1992****SERVICE MANUAL****FOREWORD**

This service manual has been prepared to provide SUBARU service personnel with the necessary information and data for the correct maintenance and repair of SUBARU vehicle.

This manual include the procedures for maintenance disassembling, reassembling, inspection and adjustment of components and troubleshooting for guidance of both the fully qualified and the less-experienced mechanics. Please peruse and utilize this manual fully to ensure complete repair work for satisfying our customers by keeping their vehicle in optimum condition. When replacement of parts during repair work is needed, be sure to use SUBARU genuine parts.

All information, illustration and specifications contained in this manual are based on the latest product information available at the time of publication approval.

FUJI HEAVY INDUSTRIES LTD.

All right reserved. This book may not be reproduced or copied, in whole or in part, without the written permission of
FUJI HEAVY INDUSTRIES LTD., TOKYO JAPAN.

SUBARU,  and  are trademarks of
FUJI HEAVY INDUSTRIES LTD.

© Copyright 1991 FUJI HEAVY INDUSTRIES LTD.

6 ELECTRICAL SECTION**ENGINE ELECTRICAL SYSTEM 6-1****BODY ELECTRICAL SYSTEM 6-2****WIRING DIAGRAM AND TROUBLESHOOTING 6-3**

IMPORTANT SAFETY NOTICE

Providing appropriate service and repair is a matter of great importance in the serviceman's safety maintenance and safe operation, function and performance which the SUBARU vehicle possesses.

In case the replacement of parts or replenishment of consumables is required, genuine SUBARU parts whose parts numbers are designated or their equivalents must be utilized.

It must be made well known that the safety of the serviceman and the safe operation of the vehicle would be jeopardized if he used any service parts, consumables, special tools and work procedure manuals which are not approved or designated by SUBARU.

How to use this manual

- This Service Manual is divided into six volumes by section so that it can be used with ease at work. Refer to the Table of Contents, select and use the necessary section.
- Each chapter in the manual is basically made of the following five types of areas.

M : Mechanism and function

S : Specifications and service data

C : Component parts

W : Service procedure

(X : Service procedure)

(Y : Service procedure)

T : Troubleshooting

- The description of each area is provided with four types of titles different in size as shown below. The Title No. or Symbol prefixes each title in order that the construction of the article and the flow of explanation can be easily understood.

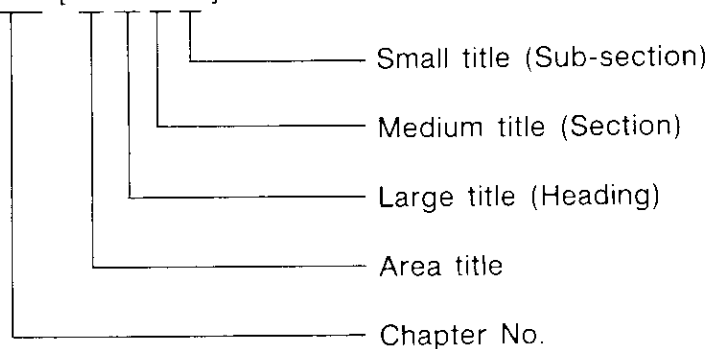
[Example of each title]

- Area title: W. Service procedure (one of the five types of areas)
- Large title (Heading): 1. Oil Pump (to denote the main item of explanation)
- Medium title (Section): A. REMOVAL (to denote the type of work in principle)
- Small title (Sub-section): 1. INNER ROTATOR (to denote a derivative item of explanation)

- The Title Index No. is indicated on the top left (or right) side of the page as the book is opened. This is useful for retrieving the necessary portion.

(Example of usage)

Refer to 2 - 4 [W 1 B 1]



Example of title placement

2-10 [W 1 A 0]

CLUTCH

W SERVICE PROCEDURE

1.General

A: PRECAUTION

When servicing clutch system, pay attention to the following items.

- 1) Check the routing of clutch cable for smoothness.
- 2) Excessive tightness or looseness of clutch cable have a bad influence upon the cable durability.
- 3) Apply grease sufficiently to the connecting portion of clutch pedal.
- 4) Apply grease sufficiently to the release lever portion.
- 5) Position clutch cable through the center of toeboard hole

Adjustment is done by


2.RELEASE LEVER

Check lever pivot portion and the point of contact with holder for wear.


2.Release Bearing and Lever

A: REMOVAL


2) Seal



- In this manual, the following symbols are used.

 : Should be lubricated with oil.

 : Should be lubricated with grease.

 : Sealing point


 : Tightening torque

TABLE OF CONTENTS

1	GENERAL SECTION	<ul style="list-style-type: none"> 1-1 Specifications 1-2 ★★★★★★★★★★ 1-3 General Information 1-4 Pre-Delivery Inspection 1-5 Periodic Maintenance Services 1-6 Special Tools
2	ENGINE SECTION	<ul style="list-style-type: none"> 2-1 Emission Control System and Vacuum Fitting 2-2 On-Car Services 2-3a Engine (SOHC) 2-3b Engine (DOHC) 2-4 Engine Lubrication System 2-5 Engine Cooling System 2-6 Carburetor 2-7a Fuel Injection System (MPFI Non-TURBO) 2-7b Fuel Injection System (SPFI) 2-7c Fuel Injection System (MPFI TURBO) 2-8 Fuel System 2-9 Exhaust System 2-10 Clutch 2-11 Engine and Transmission Mounting System
3	TRANSMISSION AND DIFFERENTIAL SECTION	<ul style="list-style-type: none"> 3-1 Manual Transmission and Differential 3-2a Automatic Transmission and Differential (4AT) 3-2b ★★★★★★★★★★ 3-3 Transmission Control System 3-4 4WD System
4	MECHANICAL COMPONENTS SECTION	<ul style="list-style-type: none"> 4-1 Suspension 4-2 Wheels and Axles 4-3 Steering System 4-4 Brakes 4-5 Pedal System and Control Cables 4-6 Heater and Ventilator 4-7 ★★★★★★★★★★
5	BODY SECTION	<ul style="list-style-type: none"> 5-1 Body and Exterior 5-2 Doors and Windows 5-3 Seats, Seat Belts, and Interior 5-4 Instrument Panel
6	ELECTRICAL SECTION	<ul style="list-style-type: none"> 6-1 Engine Electrical System 6-2 Body Electrical System 6-3 Wiring Diagram and Trouble-shooting

SUBARU®

1992

**SERVICE
MANUAL**



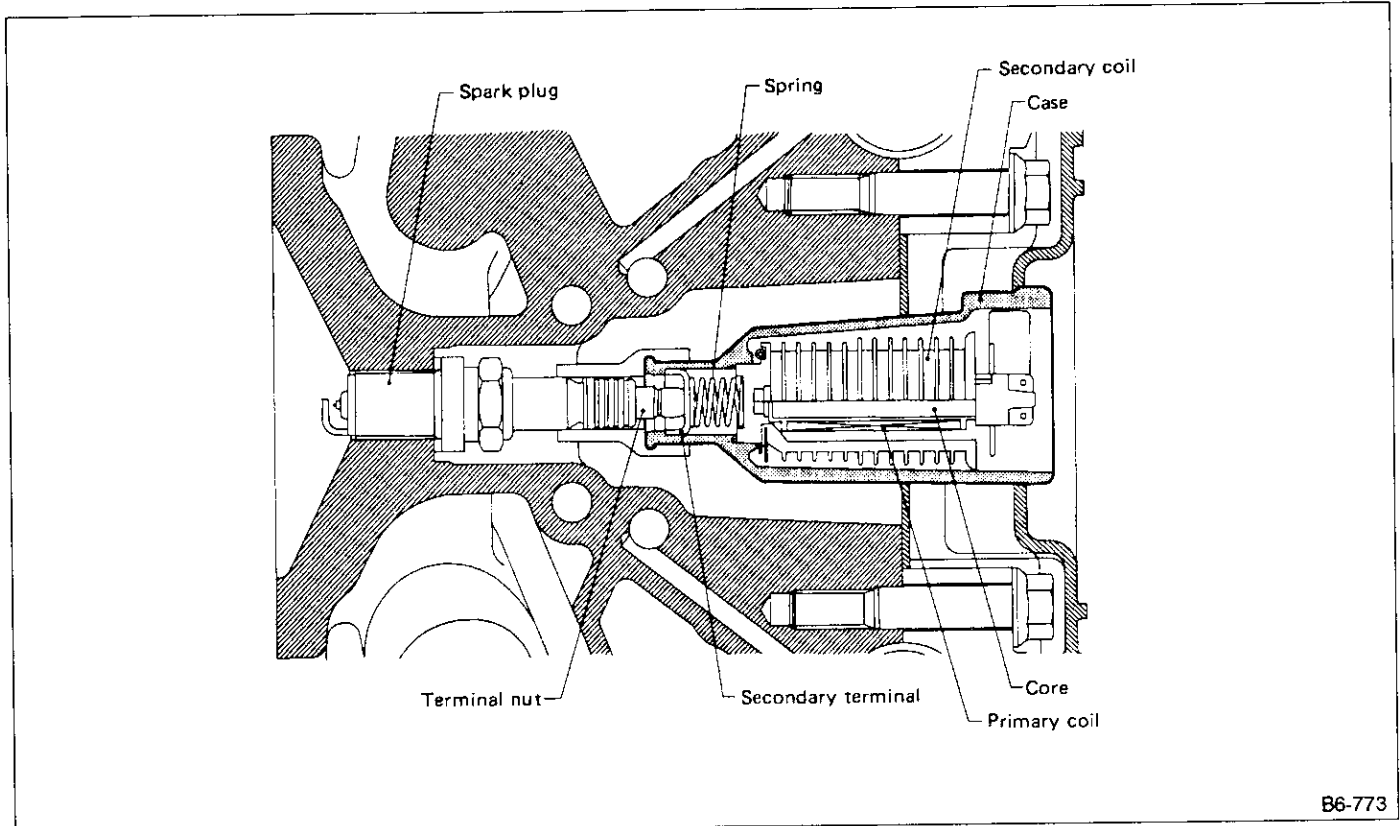
	Page
M MECHANISM AND FUNCTION	2
1. Ignition Coil (Turbo model)	2
2. Spark Plug (Turbo model)	2
S SPECIFICATIONS AND SERVICE DATA	3
C COMPONENT PARTS	5
1. Starter (NIPPONDENSO)	5
2. Starter (MITSUBISHI)	7
3. Alternator (HITACHI)	9
4. Alternator (MITSUBISHI)	10
5. Distributor	11
W SERVICE PROCEDURE	12
1. Starter (NIPPONDENSO)	12
2. Starter (MITSUBISHI)	19
3. Alternator (HITACHI)	24
4. Alternator (MITSUBISHI)	30
5. Distributor	35
6. Ignition Coil	38
7. Spark Plug	39
8. Spark Plug Cord	43
T TROUBLESHOOTING	44
1. Starter	44
2. Alternator	45

M MECHANISM AND FUNCTION

1. Ignition Coil (Turbo model)

One ignition coil is installed for each cylinder (or spark plug).
 The secondary terminal of the ignition coil is in contact with the spark plug terminal nut.

Since spark plug cable is not used, secondary voltage drop, leaks, etc. do not occur. The result is high performance reliability.

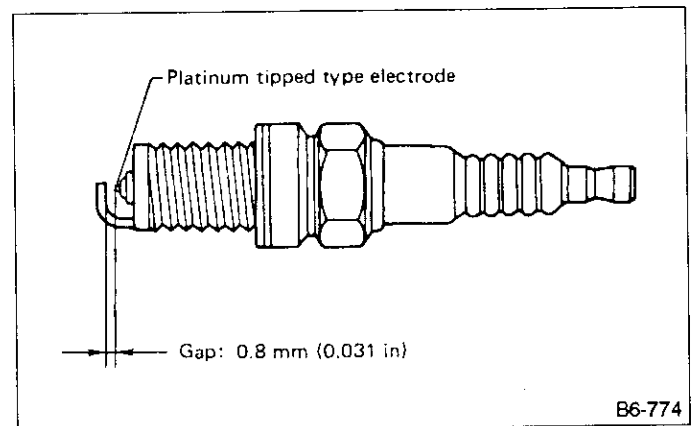


B6-773

Fig. 1

2. Spark Plug (Turbo model)

The spark plug has a platinum tipped type center electrode, with 14 mm (0.55 in) threads and 0.8 mm (0.031 in) gap.



B6-774

Fig. 2

S SPECIFICATIONS AND SERVICE DATA

A: SPECIFICATIONS

1. STARTER

		*1 MT	*2 AT	*3 AT	*4 AT	*5 MT	
Model		128000-8311	128000-8321	MIT70381A	MIT75681	MIT77181	
Type		Reduction type					
Manufacture		NIPPONDENSO			MITSUBISHI		
Voltage and output V — kW		12 — 1.0	12 — 1.4	12 — 1.0	12 — 1.4	12 — 1.0	
Direction of rotation		Counterclockwise (when observed from pinion.)					
Number of pinion teeth		9		8	9	8	
No-load characteristics		Voltage 11 V					
		Current 90 A or less					
		Rotating speed rpm 3,000 or more		2,900 or more	3,000 or more		
Load characteristics		Voltage V 8					
		Current A 280 or less		370 or less	280 or less	300 or less	280 or less
		Torque N*m (kg-m, ft-lb) 10 (1.0, 7)		14 (1.4, 10)	8.5 (0.87, 6.3)	10 (1.0, 7)	8.5 (0.87, 6.3)
		Rotating speed rpm 900 or more		880 or more	980 or more	1,000 or more	980 or more
Lock characteristics		Voltage V 5					
		Current A 800 or less		1,050 or less	780 or less	980 or less	780 or less
		Torque N*m (kg-m, ft-lb) 27 (2.8, 20) or more		18 (1.8, 13) or more	27 (2.8, 20) or more	18 (1.8, 13) or more	18 (1.8, 13) or more

*1: MT models (except 2000cc Non-Turbo model)

*2: All 4WD models and Europe FWD (except 2000cc Non-Turbo model)

*3: FWD models (except Europe and 2000cc Non-Turbo model)

*4: 2000cc Non-Turbo model

*5: 2000cc Non-Turbo model

2. ALTERNATOR

	2200cc, 2000cc Turbo	1600cc, 1800cc, 2000cc Non-Turbo
Model	LR170-732C	A2T09591
Type	Rotating-field three-phase type, voltage regulator built-in type	
Manufacture	HITACHI	MITSUBISHI
Voltage and output	12 V — 70 A	
Polarity on ground side	Negative	
Rotating direction	Clockwise (when observed from pulley side.)	
Armature connection	3-phase Y-type	
Rectifying system	Full wave rectification by eight self-contained silicone diodes	
Revolution speed at 13.5 V 20°C (68°F)	1,000 rpm or less	700 rpm or less
Output current	1,500 rpm — 33 A or more 3,000 rpm — 66 A or more 6,000 rpm — 80 A or more	1,500 rpm — 35 A or more 2,500 rpm — 60 A or more 5,000 rpm — 77 A or more
Regulated voltage at 20°C (68°F)	14.1 — 14.8 V	14.2 — 14.8 V

3. DISTRIBUTOR

		Carburetor (1800cc MT, 3AT)	Carburetor (1800cc 4AT)	Carburetor (1600cc)
Model		T2T82371A	T2T82372A	T2T82373A
Type		Breaker less type with control unit, centrifugal governor and vacuum diaphragm		
Manufacture		MITSUBISHI		
Firing order		1-3-2-4		
Rotating direction		Counterclockwise		
Air gap mm (in)		0.25 (0.0098)		
Cap insulation resistance		More than 50 MΩ		
Rotor head insulation resistance		More than 50 MΩ		
Advancing characteristic	Centrifugal advancer Advance angle (deg.)/ Distributor speed (rpm)	0°/450 10°/1,400 12.5°/3,000	0°/600 10°/1,800 12.5°/3,200	0°/600 13°/1,600 19°/3,000
	Vacuum advancer Advance angle (deg.)/ Vacuum [- kPa (- mmHg, - inHg)]	Chamber A: 0°/16.7 (125, 4.92) 12°/46.7 (350, 13.78) Chamber B: 0°/37.3 (280, 11.02) 8°/53.3 (400, 15.75)	Chamber A: 0°/16.7 (125, 4.92) 11°/46.7 (350, 13.78) Chamber B: 0°/33.3 (250, 9.84) 6°/53.3 (400, 15.75)	Chamber A: 0°/16.7 (125, 4.92) 8°/46.7 (350, 13.78) Chamber B: 0°/33.3 (250, 9.84) 6°/53.3 (400, 15.75)

4. IGNITION COIL

	MPFI (Non-TURBO)	MPFI-TURBO	SPFI	Carburetor
Model	CM12-100	F523	CM1T-214	E-083
Manufacturer	HITACHI	DIAMOND	HITACHI	DIAMOND
Primary coil resistance	0.63 — 0.77 Ω	0.68 — 0.83 Ω	0.81 — 0.99 Ω	1.4 — 1.7 Ω
Secondary coil resistance	10.4 — 15.6 kΩ	—	8 — 12 Ω	12.8 — 17.3 Ω
Insulation resistance between primary terminal and case	More than 10 MΩ	More than 10 MΩ	More than 10 MΩ	More than 10 MΩ

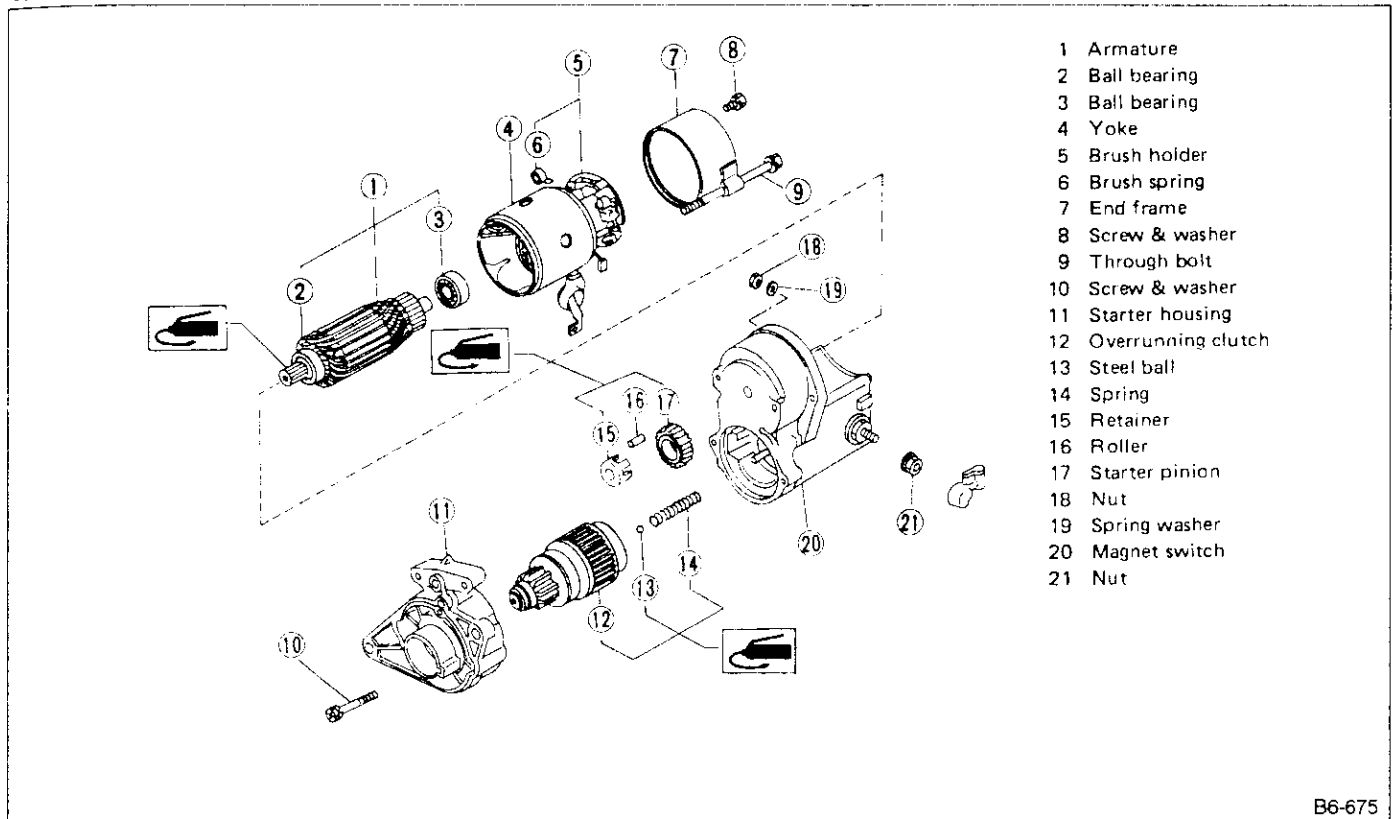
5. SPARK PLUG

	MPFI-TURBO	MPFI with O ₂ sensor, SPFI	MPFI without O ₂ sensor, Carburetor
Type and Manufacturer	BKR6EVX (or BKR7EVX, PFR6G, PFR7G) ... NGK	BKR6E-11 (or BKR5E-11, BKR7E-11) ... NGK K20PR-U11 (or K16PR-U11, K22PR-U11) ... NIPPON DENSO	BKR6E (or BKR5E, BKR7E) ... NGK K20PR-U (or K16PR-U, K22PR-U) ... NIPPON DENSO
Thread size mm	14, P = 1.25		
Spark gap mm (in)	0.8 (0.031)	1.1(0.043)	0.8 (0.031)

C COMPONENT PARTS

1. Starter (NIPPONDENSO)

1. 128000-8311



B6-675

Fig. 3

2. 128000-8321

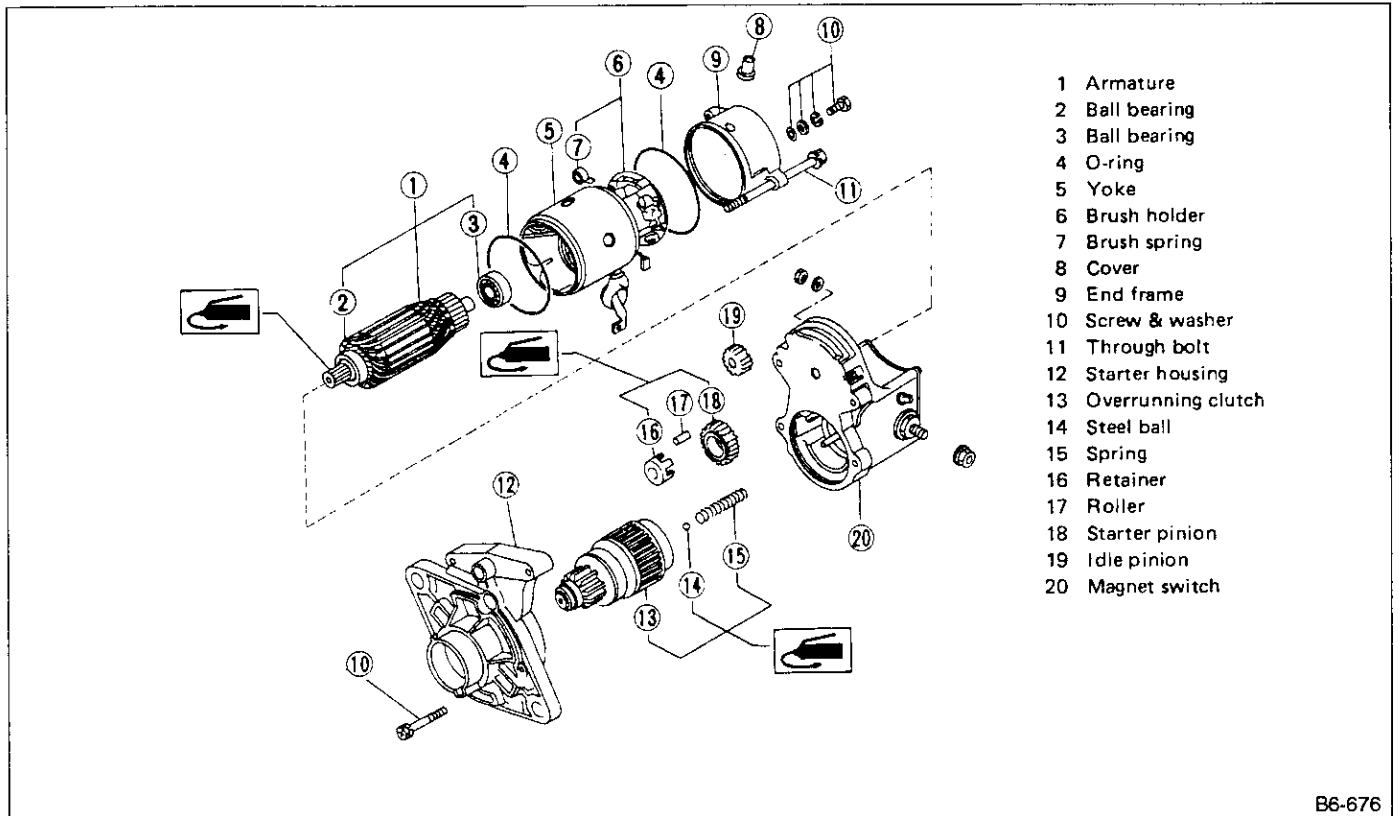


Fig. 4

B6-676

2. Starter (MITSUBISHI)

1. MIT70381A, MIT75681

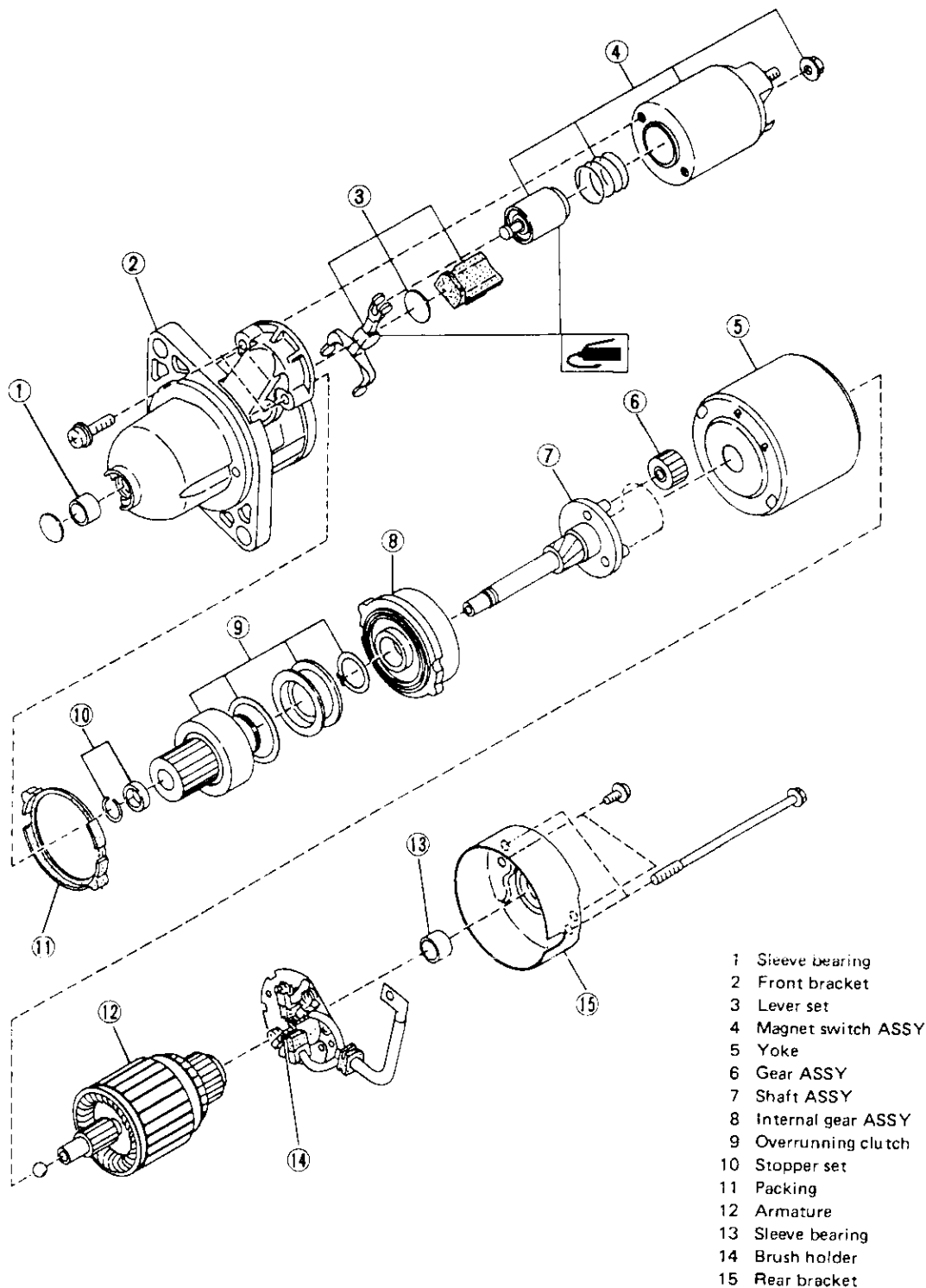


Fig. 5

B6-761

2. MIT77181

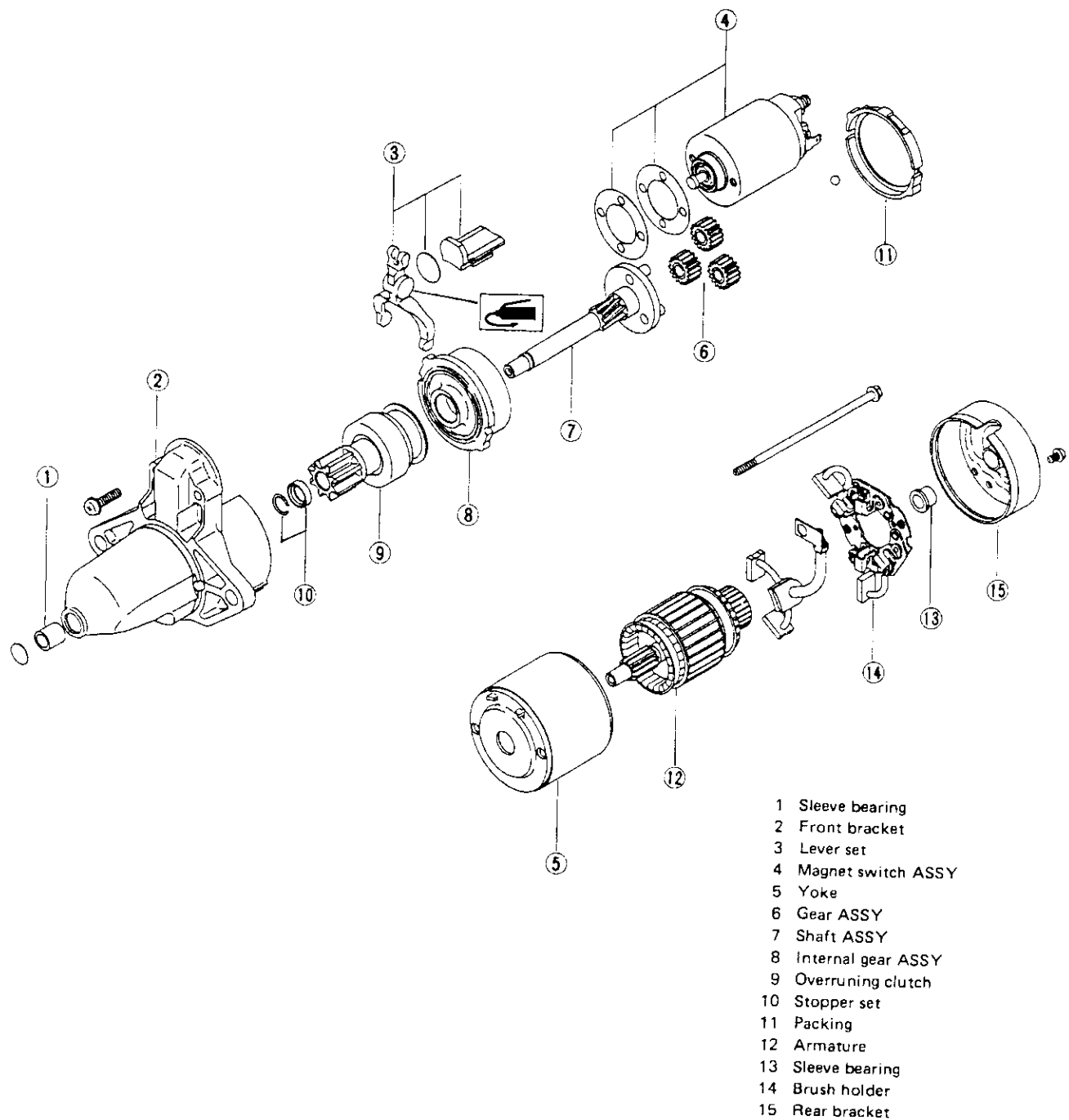
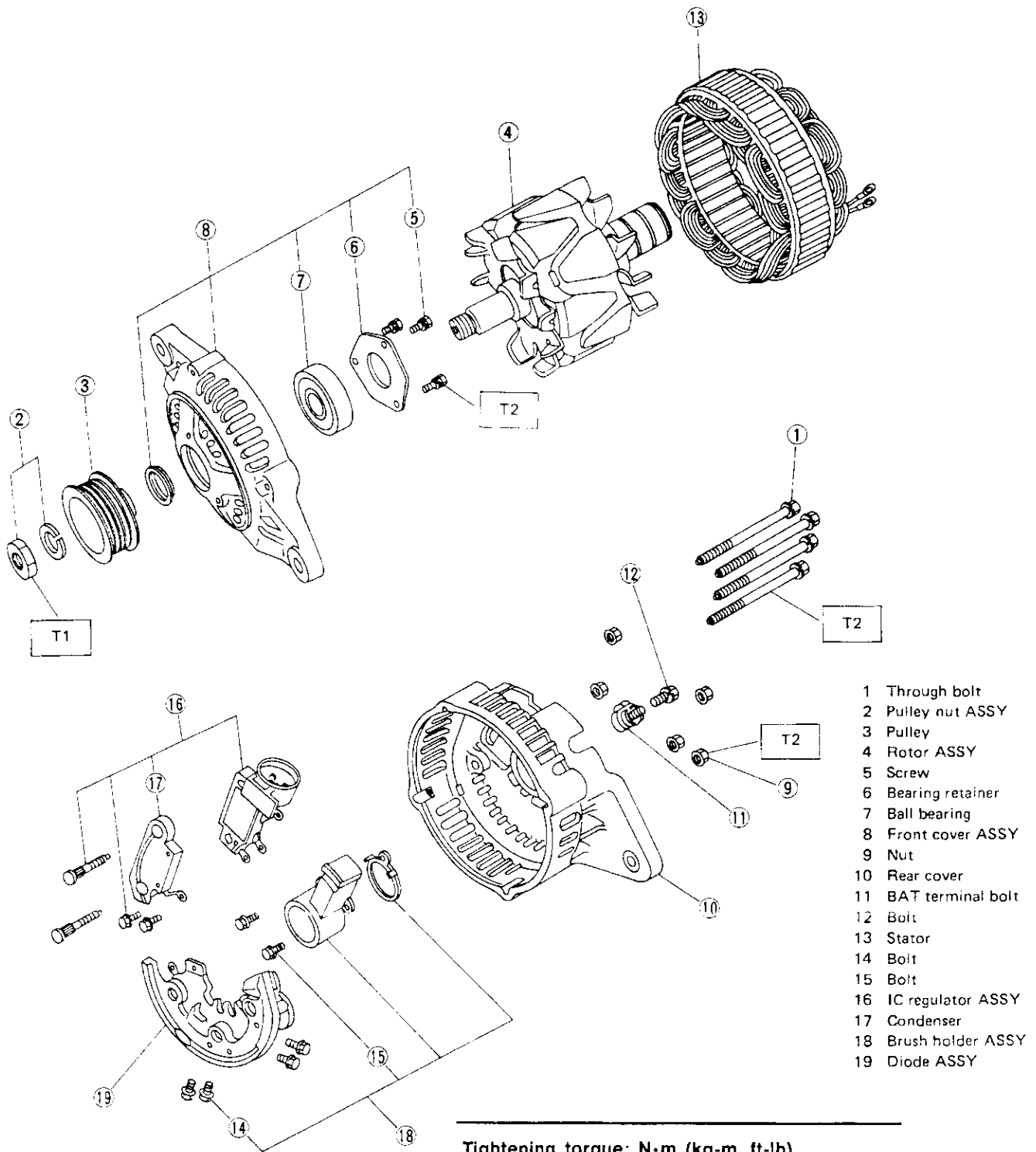


Fig. 6

B6-762

3. Alternator (HITACHI)



- 1 Through bolt
- 2 Pulley nut ASSY
- 3 Pulley
- 4 Rotor ASSY
- 5 Screw
- 6 Bearing retainer
- 7 Ball bearing
- 8 Front cover ASSY
- 9 Nut
- 10 Rear cover
- 11 BAT terminal bolt
- 12 Bolt
- 13 Stator
- 14 Bolt
- 15 Bolt
- 16 IC regulator ASSY
- 17 Condenser
- 18 Brush holder ASSY
- 19 Diode ASSY

Tightening torque: N·m (kg-m, ft-lb)
T1: 49.0 — 63.7 (5.00 — 6.50, 36.2 — 47.0)
T2: 3.1 — 3.9 (0.32 — 0.40, 2.3 — 2.9)

Fig. 7

4. Alternator (MITSUBISHI)

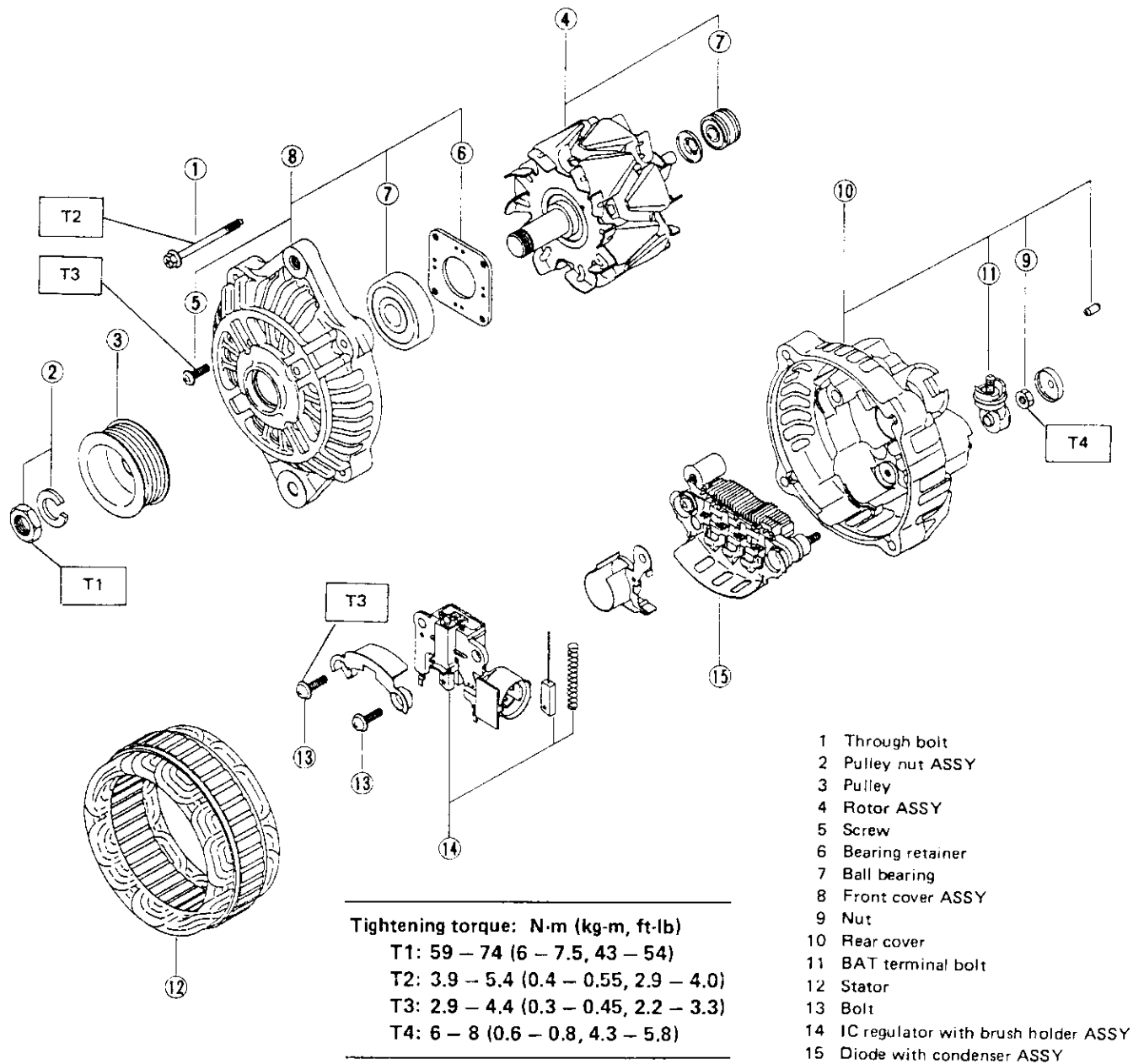


Fig. 8

5. Distributor

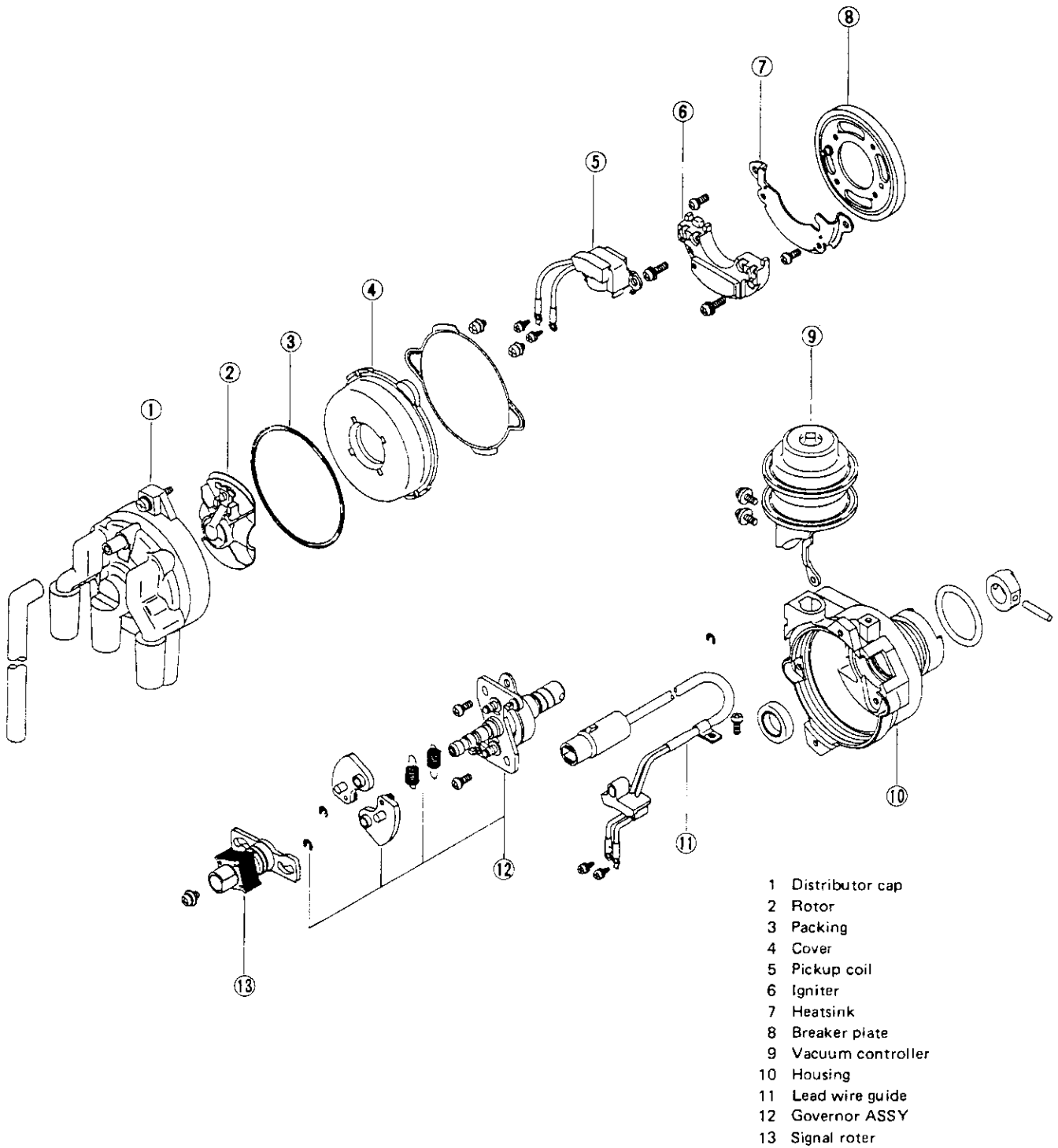


Fig. 9

B6-764

W SERVICE PROCEDURE

1. Starter (NIPPONDENSO)

A: TEST

1. MAGNETIC SWITCH OPERATION

- a. The following magnetic switch tests should be performed with specified voltage applied.
- b. Each test should be conducted within 3 to 5 seconds. Power to be furnished should be one-half the rated voltage.

1) Pull-in test

Connect two battery negative leads onto magnetic switch body and terminal C respectively. Then connect battery positive lead onto terminal 50. Pinion should extend when lead connections are made.

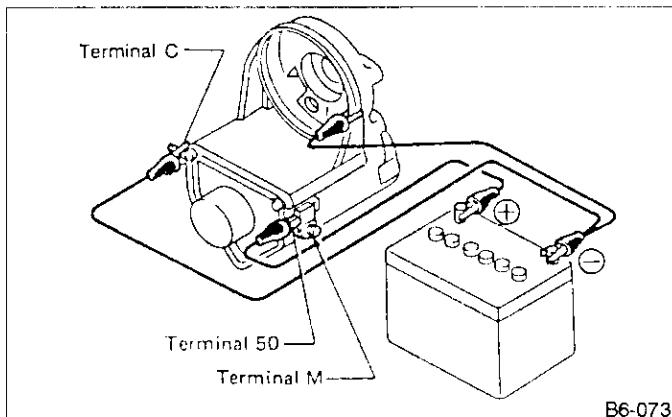


Fig. 10

2) Holding-in test

Disconnect lead from terminal C with pinion extended. Pinion should be held in the extended position.

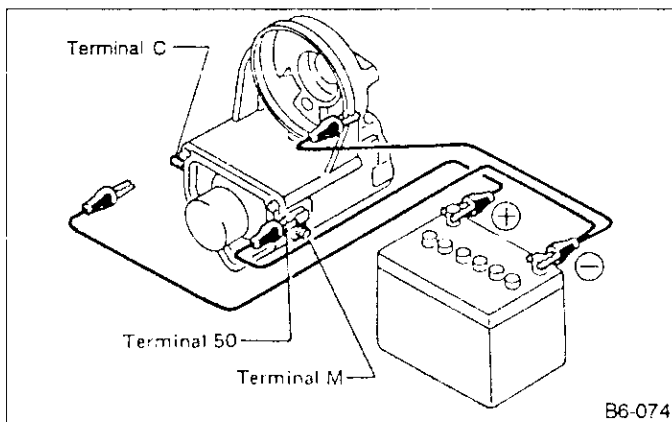


Fig. 11

3) Return test

Connect two battery negative leads onto terminal 5 and onto switch body respectively. Then connect battery positive lead onto terminal C. Next, disconnect lead from terminal 50. Pinion should return immediately.

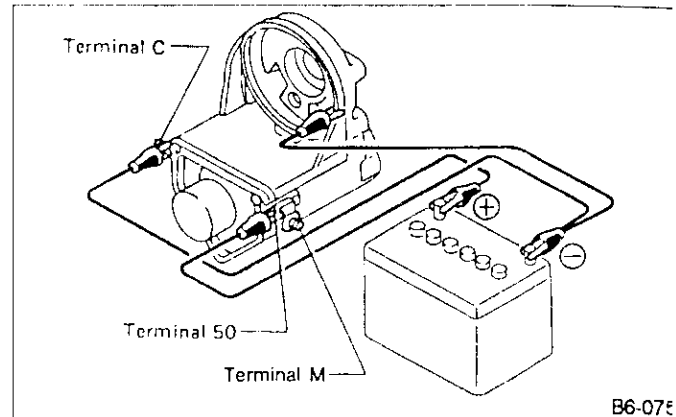


Fig. 12

2. PERFORMANCE TEST

The starter is required to produce a large torque at a high rotating speed, but these starter characteristics vary with the capacity of the battery. It is therefore important to use a battery with the specified capacity whenever testing the starter.

The starter should be checked for the following three items.

1. No-load test: Measure the maximum rotating speed and current under a no-load state.
2. Load test: Measure the magnitude of current needed to generate the specified torque and rotating speed.
3. Stall test: Measure the torque and current when the armature is locked.

1) No-load test

Run single starter under no-load state, and measure its rotating speed, voltage, and current, using the specified battery. Measured values must meet the following standards:

No-load test (Standard):

Voltage/Current

11 V/90 A max.

Rotating speed

128000-8311: 3,000 rpm/min.

128000-8321: 2,900 rpm/min.

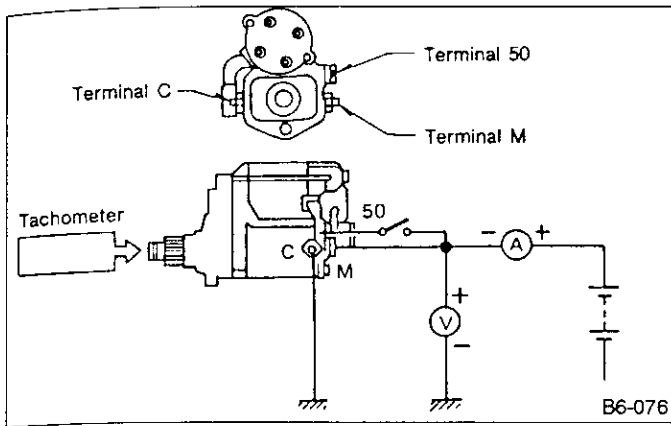


Fig. 13

2) Load test (For reference)

Perform this test to check maximum output of starter. Use test bench which is able to apply load (brake) to starter. Measure torque value and rotating speed under the specified voltage and current conditions while controlling braking force applied to starter.

Change engagement position of overrunning clutch and make sure it is not slipping.

Load test (Standard):

128000-8311

Voltage/Load

8 V/10 N·m (1.0 kg-m, 7 ft-lb)

Current/Speed

280 A max./900 rpm min.

128000-8321

Voltage/Load

8 V/14 N·m (1.4 kg-m, 10 ft-lb)

Current/Speed

370 A max./880 rpm min.

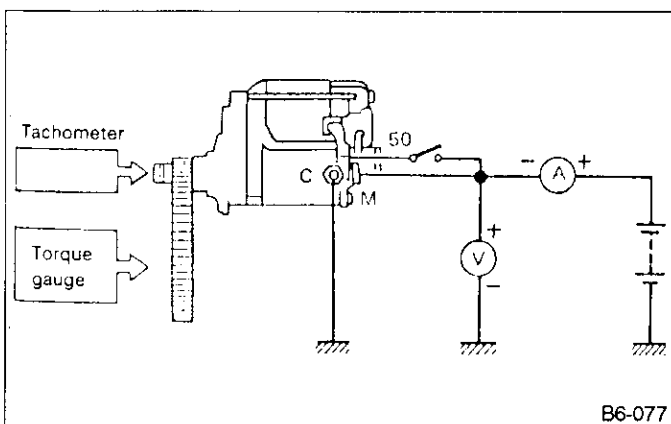


Fig. 14

3) Stall test

Using the same test equipment used for load test, apply brake to lock starter armature. Then measure voltage, current, and torque values.

Measured values must meet the following standard.

Stall test (Standard):

128000-8311

Voltage/Current

5 V/800A max.

Torque

27 N·m (2.8 kg-m, 20 ft-lb) min.

128000-8321

Voltage/Current

5 V/1,050 A max.

Torque

27 N·m (2.8 kg-m, 20 ft-lb) min.

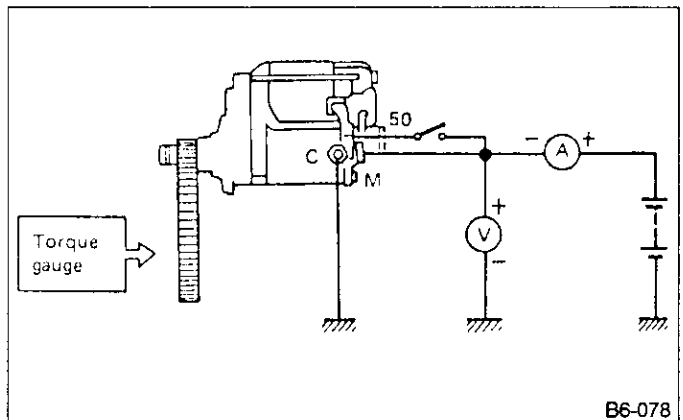


Fig. 15

Low rotating speed or excessive current during no-load test may be attributable to high rotating resistance of starter due to improper assembling.

Small current and no torque during stall test may be attributable to excessive contact resistance between brush and commutator; whereas, normal current and insufficient torque may be attributable to shorted commutator or poor insulation.

Starter can be considered normal if it passes no-load and stall tests; therefore, load test may be omitted.

B: DISASSEMBLY

- 1) Disconnect lead wire from magnetic switch.

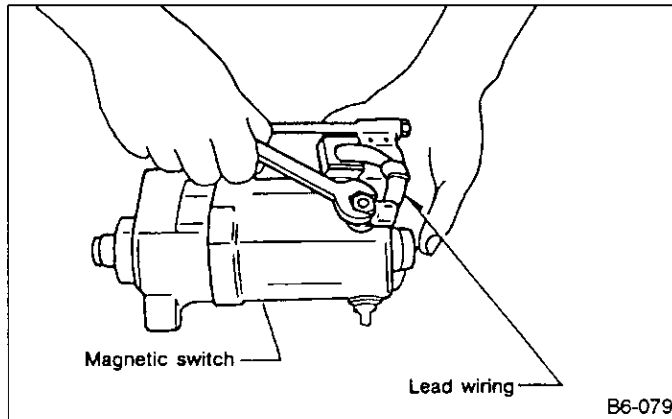


Fig. 16

- 2) Remove through-bolts from end frame.

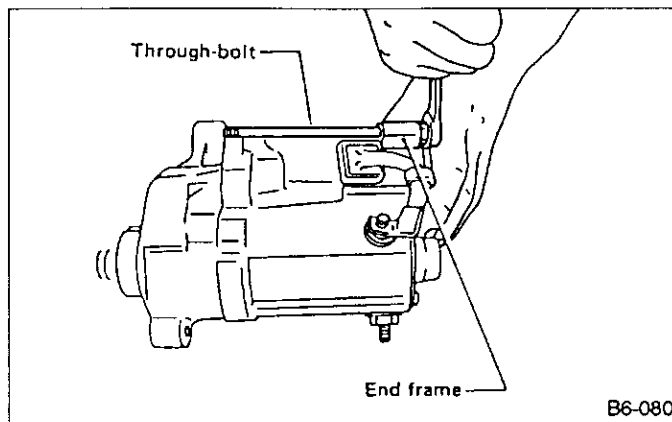


Fig. 17

- 3) Remove yoke from magnetic switch.

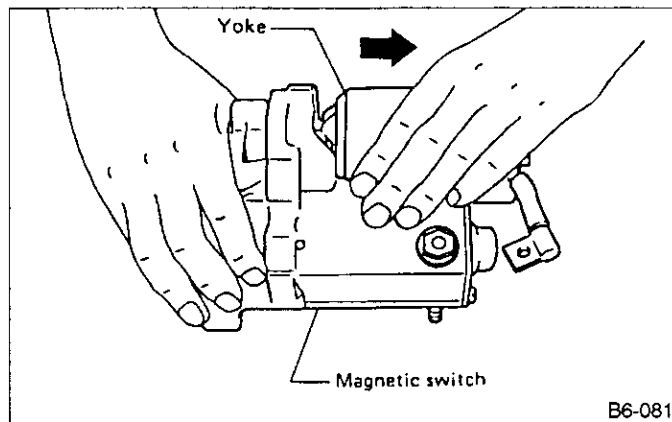


Fig. 18

- 4) Remove screws securing end frame to brush holder.

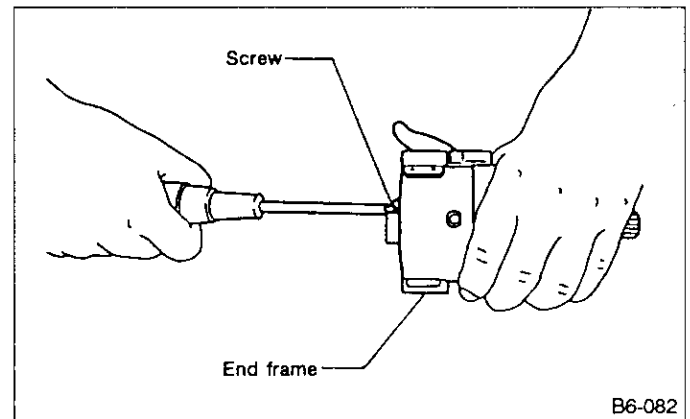


Fig. 19

- 5) Separate yoke from end frame.

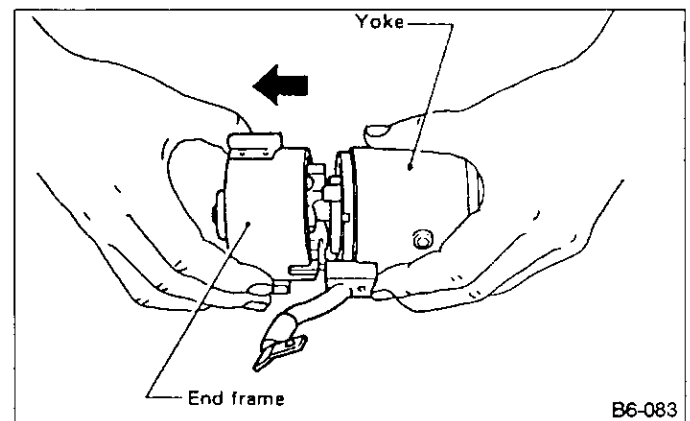


Fig. 20

- 6) Remove brush by lifting up positive (+) side brush spring using long-nose pliers.

Be careful not to damage brush and commutator.

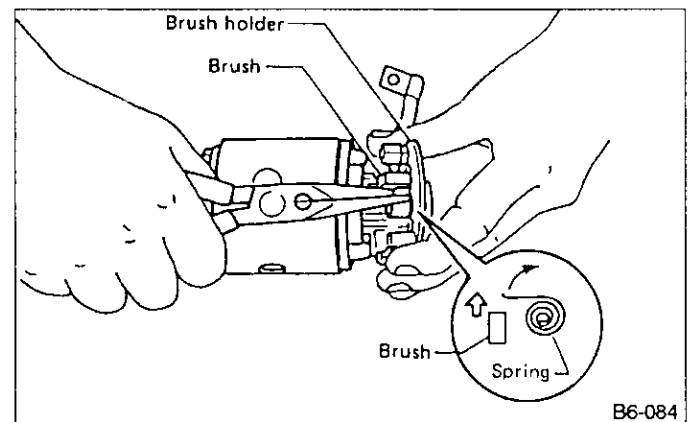


Fig. 21

7) Remove armature from yoke.

Be careful not to drop armature.

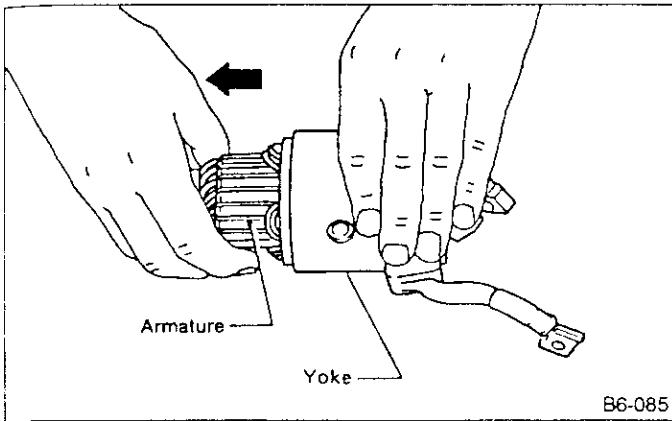


Fig. 22

8) Remove screws securing magnetic switch to housing.

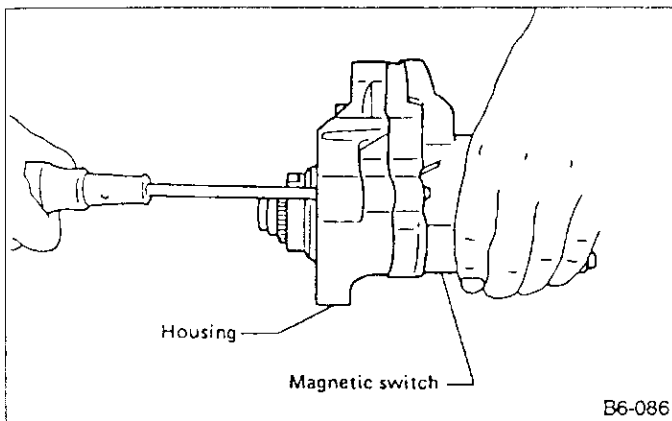


Fig. 23

Remove housing from magnetic switch.

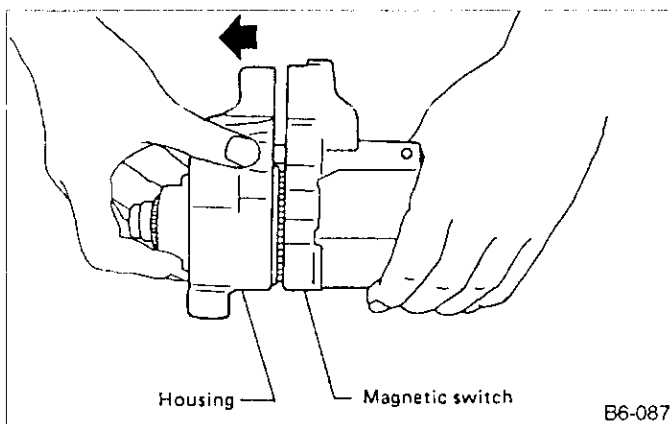


Fig. 24

9) Remove clutch from housing.

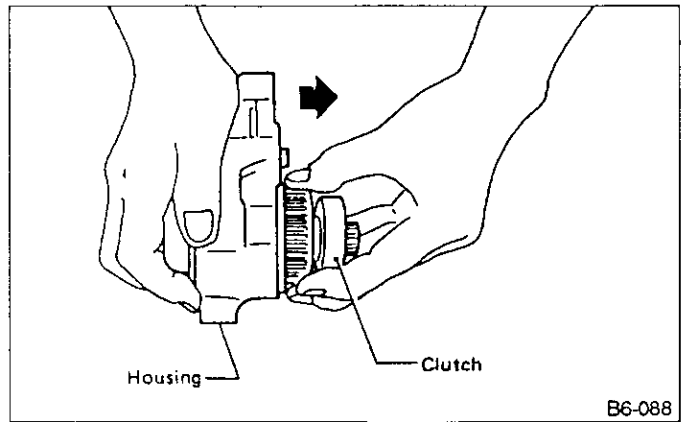


Fig. 25

10) Take out steel ball from clutch.

Be careful not to lose steel ball.

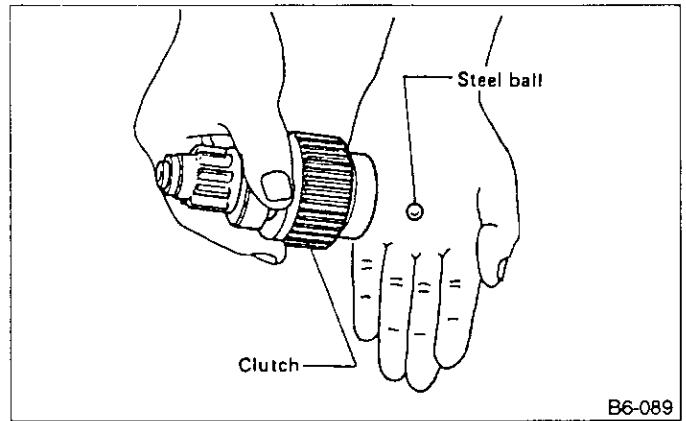


Fig. 26

11) Remove idle gear from housing.

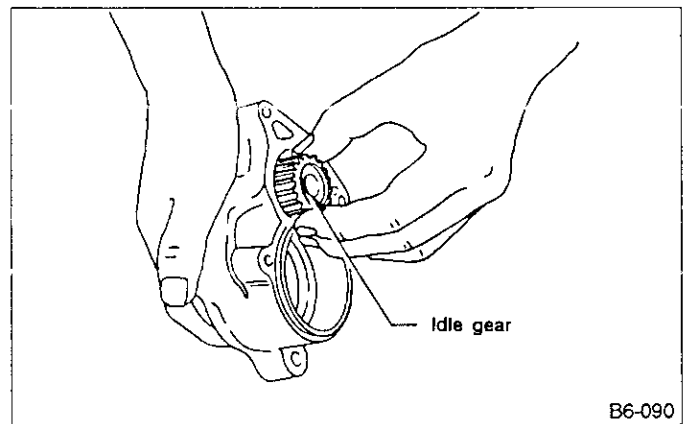


Fig. 27

- 12) Remove retainer and roller from housing.
Be careful not to drop retainer and roller.

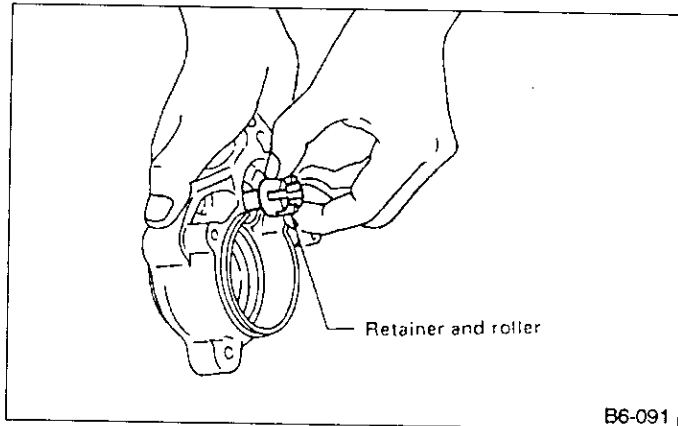


Fig. 28

- 13) Remove coil spring from magnetic switch.

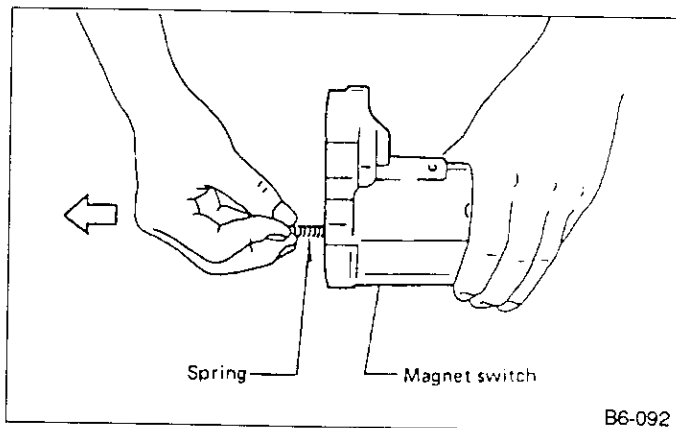


Fig. 29

C: INSPECTION AND REPAIR

1. ARMATURE

- 1) Layer test
 Check armature coil for short-circuit between layers by using growler tester.

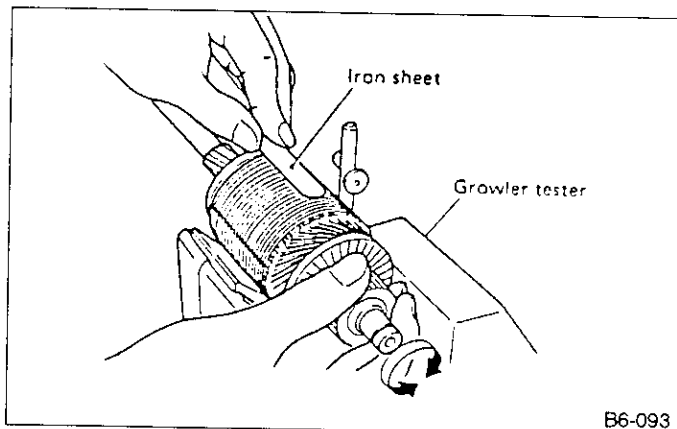


Fig. 30

If any short-circuit exists in armature coil, circulating current is generated by alternating flux of growler tester, and the affected portion of the armature core is magnetized.

If an iron piece is brought close to that portion, it will vibrate, locating the short-circuit.

Before performing the test, thoroughly remove carbon powder, etc. from around the commutator.

- 2) Insulation test
 Check insulation between commutator and armature core using 500 V megger.
 Insulation resistance should be 10 MΩ or larger.

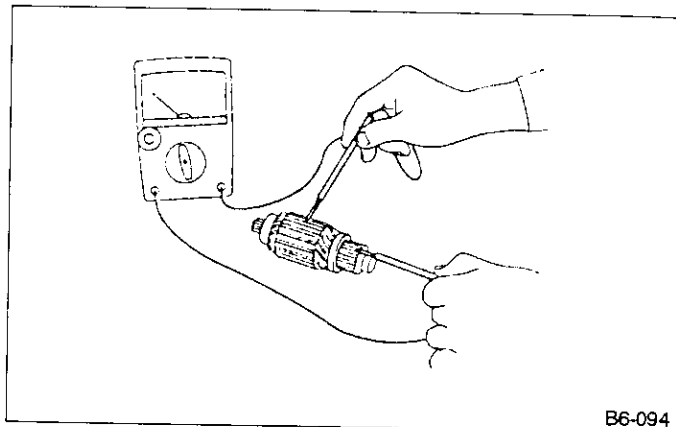


Fig. 31

- 3) Check commutator for out of roundness.
 Use dial gauge to check that commutator is round.
 Repair commutator using lathe if uneven wear is found.

Out of roundness:
 Standard
 0.02 mm (0.0008 in) or less
 Limit
 0.05 mm (0.0020 in)

Be sure to perform this check after checking armature shaft for bend.

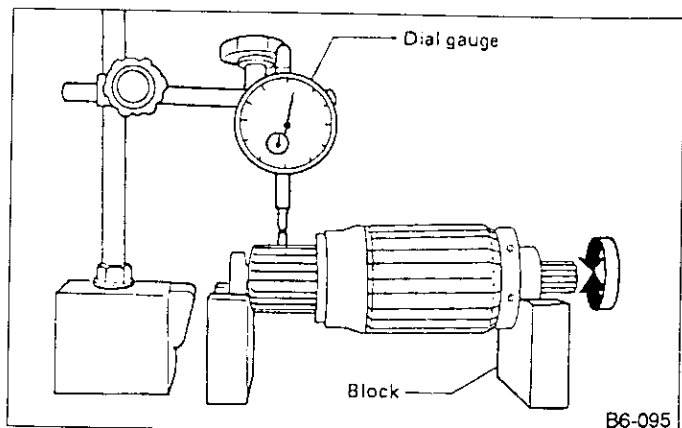


Fig. 32

If commutator surface is rough, polish with fine grain sand paper (#300); if burnt excessively, correct by cutting with a lathe.

In repairing commutator with lathe, do not reduce commutator O.D. by more than 1 mm (0.04 in) from its original (standard) value. Excessive cutting will hamper commutator durability.

After repairing, polish finished surface with sand paper.

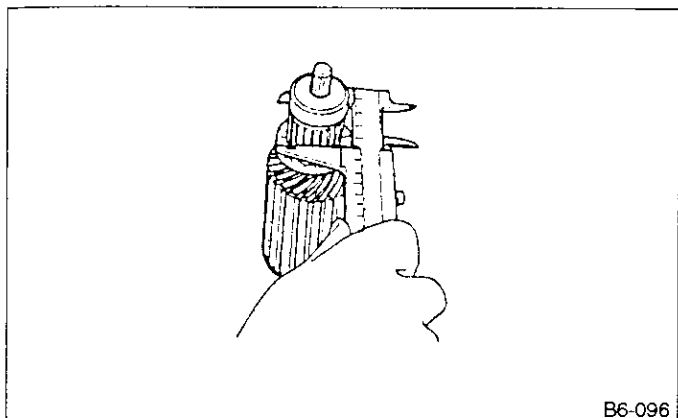
Commutator O.D.:

Standard

30 mm (1.18 in)

Limit

29 mm (1.14 in)



B6-096

Fig. 33

4) Under-cutting of commutator

If commutator segments wear and mica insulation between segments stand higher than segment face, proper rectification is hampered.

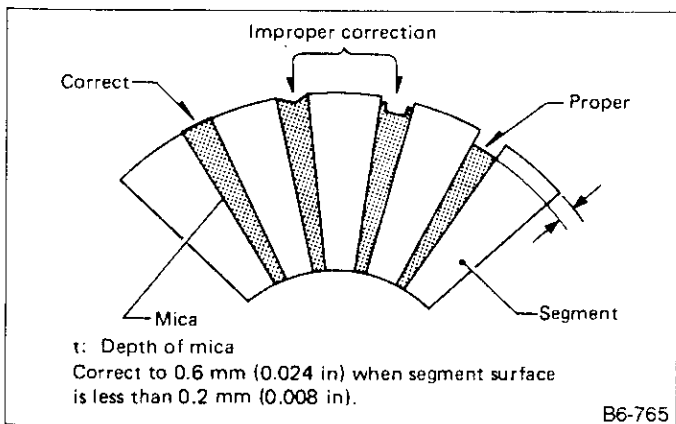
Depth of mica:

Standard

0.6 mm (0.024 in)

Limit

0.2 mm (0.008 in)



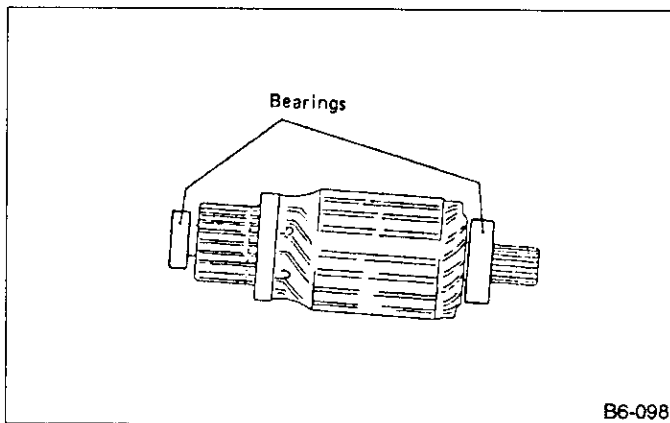
B6-765

Fig. 34

2. BEARING

1) Inspection

- (1) Rotate bearing by hand; no binding should exist.
- (2) Rotate bearing rapidly; no abnormal noise should be heard.

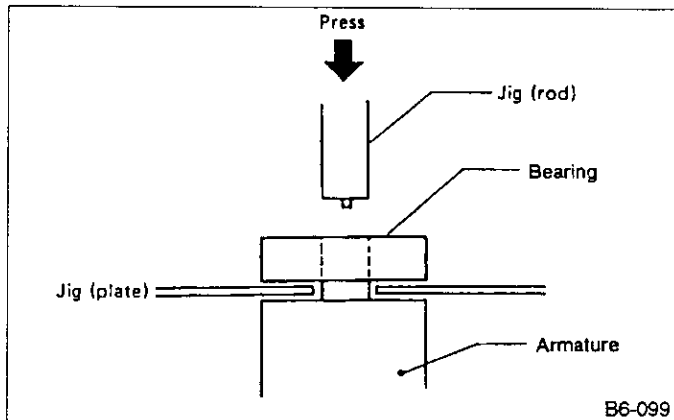


B6-098

Fig. 35

2) Replacement

Pull out bearing using a jig as shown in Figure.



B6-099

Fig. 36

3. YOKE

1) Testing field coil for open circuit

Check field coil for continuity using circuit tester. Continuity should exist.

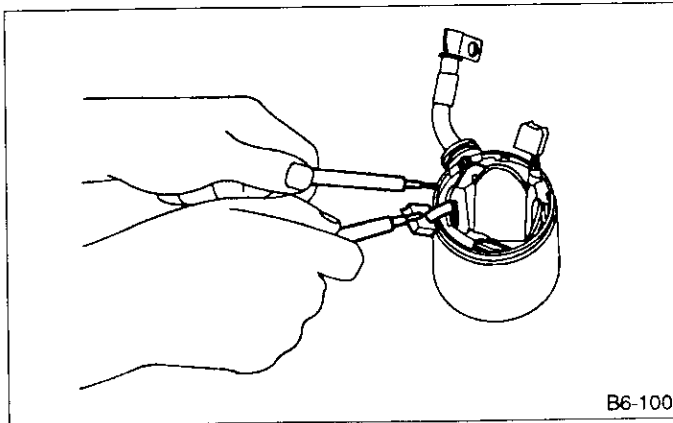


Fig. 37

2) Checking carbon brush

If carbon brush length has been reduced by more than 1/3 the original length, or if brush contact area has been reduced largely due to brush breakage, replace carbon brush.

Brush length:

Standard

15 mm (0.59 in)

Limit

10 mm (0.39 in)

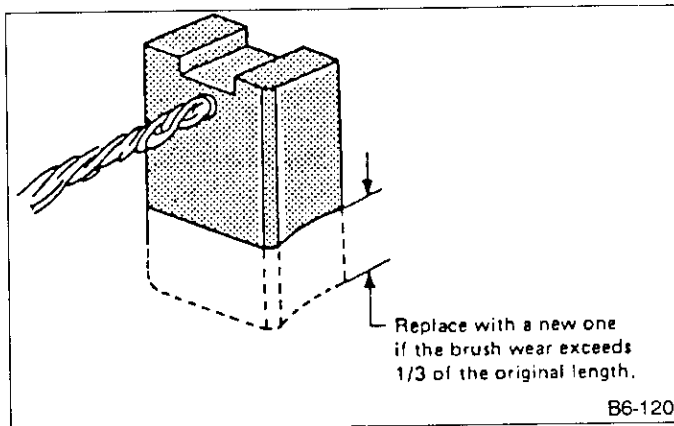


Fig. 38

4. BRUSH HOLDER

Measure insulation resistance of brush holder using Megger.

Insulation resistance:

10 MΩ or over

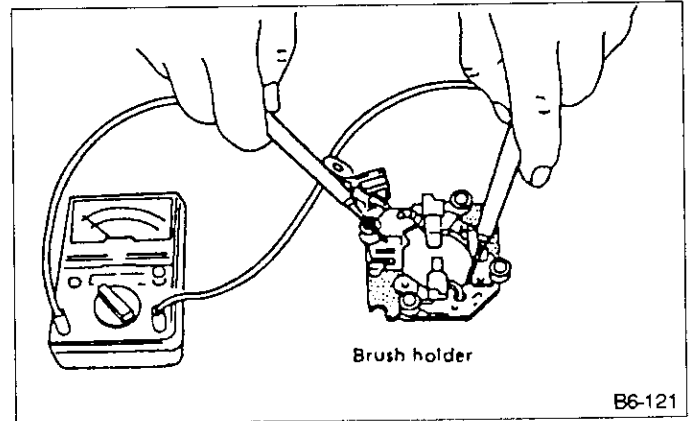


Fig. 39

5. CLUTCH

Check that pinion can be rotated in normal direction only.

Check pinion gear for wear, damage, rusting, or binding during rotation.

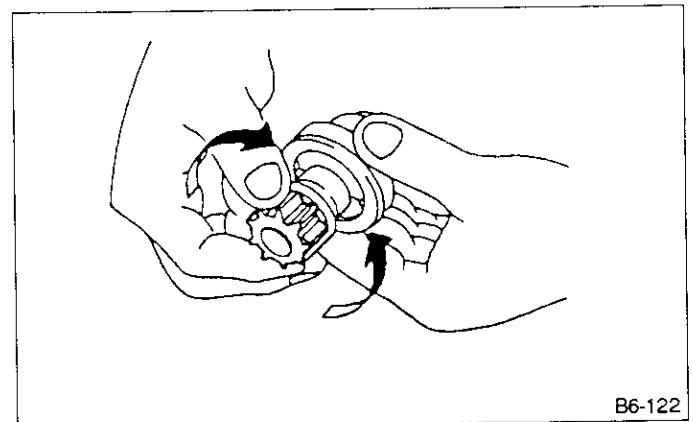


Fig. 40

D: ASSEMBLY

Assembly is in the reverse order of disassembly procedures. Observe the following:

1) Before assembling, lubricate disassembled parts at the points shown in Fig. 1 and Fig. 2.

Grease:

ESSO BEACON 325

SHELL ALVANIA GREASE RA or equivalent

2) Assembling magnetic switch, clutch, and housing
To assemble, first install clutch to magnetic switch, then install idle gear, and finally install clutch.

- a. Do not forget to install steel ball and coil spring to clutch.
- b. Attach bearing to idle gear beforehand.

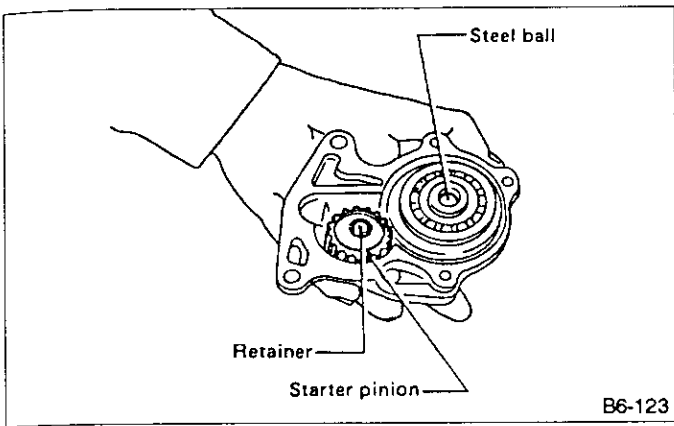


Fig. 41

3) Installing armature to yoke

Do not forget to put felt washer on armature shaft bearing.

4) Installing brushes

Assemble brush holder to yoke as shown, then assemble two yoke-side brushes to brush holder.

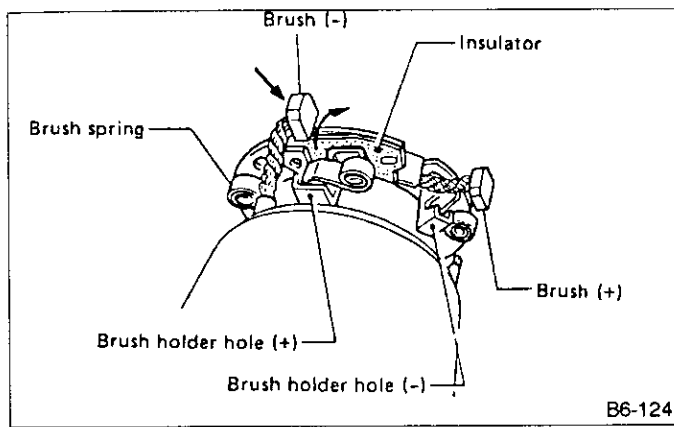


Fig. 42

5) Installing end frame

When assembling end frame to yoke, align notched portion of end frame with lead wire grommet.

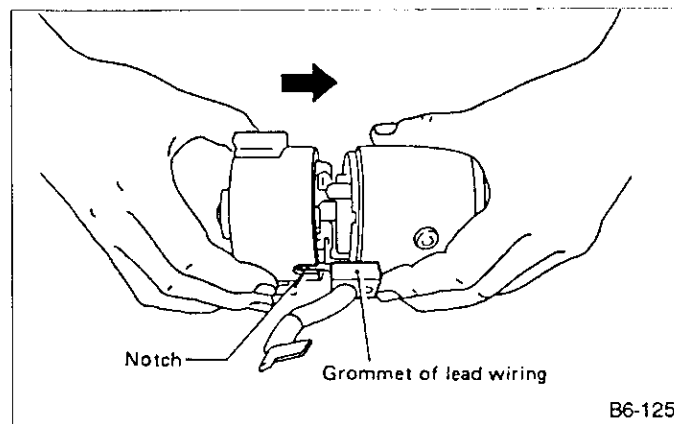


Fig. 43

6) Installing yoke

When installing yoke to magnetic switch, align notch of yoke with protrusion of magnetic switch.

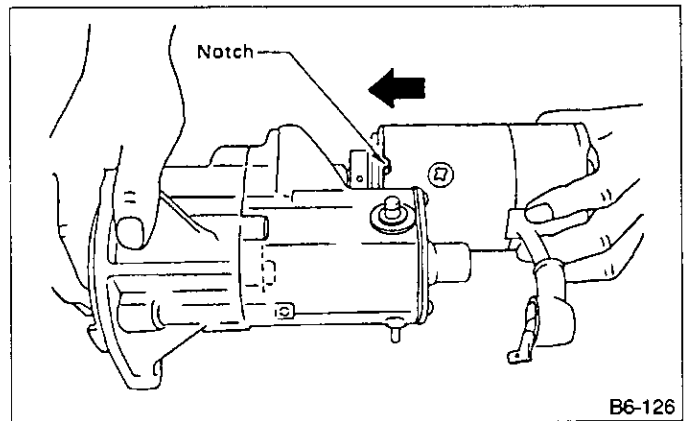


Fig. 44

2. Starter (MITSUBISHI)

A: TEST

1. SWITCH ASSEMBLY OPERATION

1) Connect terminal S of switch ASSY to positive terminal of battery with a lead wire, and starter body to ground terminal of battery. Pinion should be forced endwise on shaft.

With pinion forced endwise on shaft, starter motor can sometimes rotate because current flows, through pull-in coil, to motor. This is not a problem.

2) Disconnect connector from terminal M, and connect positive terminal of battery to terminal M using a lead wire and ground terminal to starter body. In this test setup, pinion should return to its original position even when it is pulled out with a screwdriver.

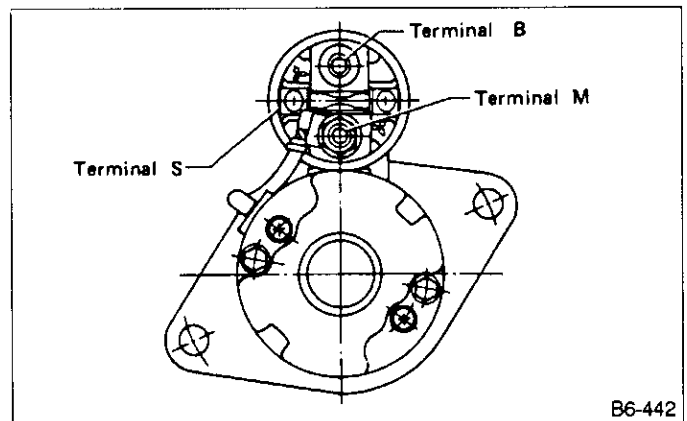


Fig. 45

2. PINION GAP

1) With pinion forced endwise on shaft, as outlined in step 1) above, measure pinion gap.

Pinion gap:

0.5 — 2.0 mm (0.020 — 0.079 in)

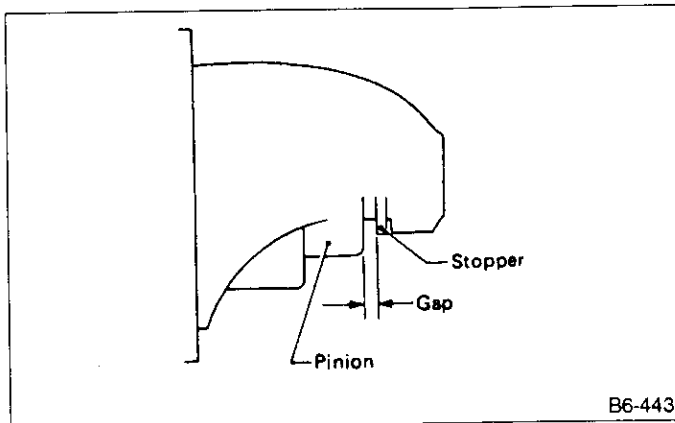


Fig. 46

If motor is running with the pinion forced endwise on the shaft, disconnect connector from terminal M of switch ASSY to stop pinion turning. Next, gently push pinion back with your fingertips and measure pinion gap.

2) If pinion gap is outside specified range, remove or add number of adjustment washers used on the mounting surface of switch ASSY until correct pinion gap is obtained.

3. PERFORMANCE TEST

The starter should be submitted to performance tests whenever it has been overhauled, to assure its satisfactory performance when installed on the engine. Three performance tests, no-load test, load test, and lock test, are presented here; however, if the load test and lock test cannot be performed, carry out at least the no-load test.

For these performance tests, use the circuit shown in figure.

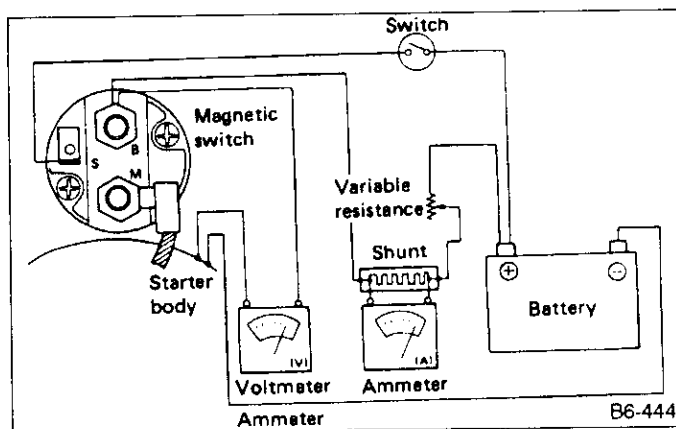


Fig. 47

1) No-load test

With switch on, adjust the variable resistance to obtain 11 V, take the ammeter reading and measure the starter speed. Compare these values with the specifications.

No-load test (Standard):

Voltage/Current
11 V/90 A max.
Rotating speed
3,000 rpm/min.

2) Load test

Apply the specified braking torque to starter. The condition is satisfactory if the current draw and starter speed are within specifications.

Load test (Standard):

Voltage/Load
MIT70381A, MIT77181
8 V/8.5 N•m (0.87 kg-m, 6.3 ft-lb)
MIT75681
7.7 V/10 N•m (1.0 kg-m, 7 ft-lb)
Current/Speed
MIT70381A, MIT77181
280 A max./980 rpm/min.
MIT75681
300 A max./1,000 rpm/min.

3) Lock test

With starter stalled, or not rotating, measure the torque developed and current draw when the voltage is adjusted to the specified voltage.

Lock test (Standard):

Voltage/Current
MIT70381A, MIT77181
4 V/780 A max.
MIT75681
4 V/980 A max.
Torque
MIT70381A, MIT77181
18 N•m (1.8 kg-m, 13 ft-lb) min.
MIT75681
27 N•m (2.8 kg-m, 20 ft-lb) min.

B: DISASSEMBLY

- 1) Loosen nut which holds terminal M of switch ASSY, and disconnect connector.
- 2) Remove bolts which hold switch ASSY, and remove switch ASSY, plunger and plunger spring from starter as a unit.

Be careful because pinion gap adjustment washer may sometimes be used on the mounting surface of switch ASSY.

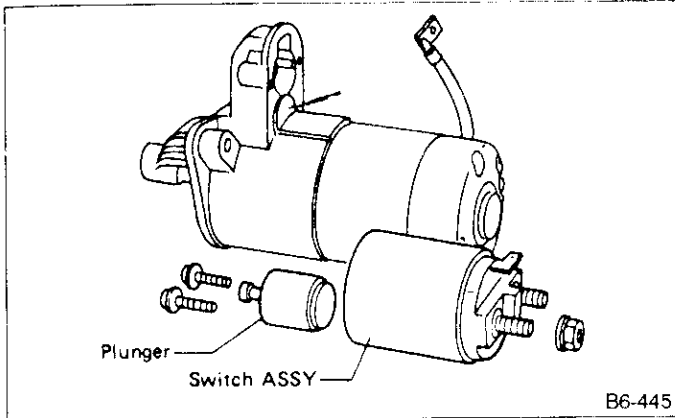


Fig. 48

- 3) Remove both through-bolts and brush holder screws, and detach rear bracket and brush holder.

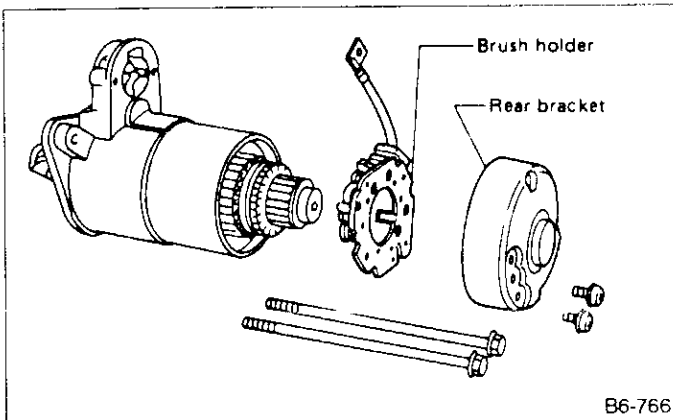


Fig. 49

- 4) Remove armature and yoke. Ball used as a bearing will then be removed from the end of armature.

Be sure to mark an alignment mark on yoke and front bracket before removing yoke.

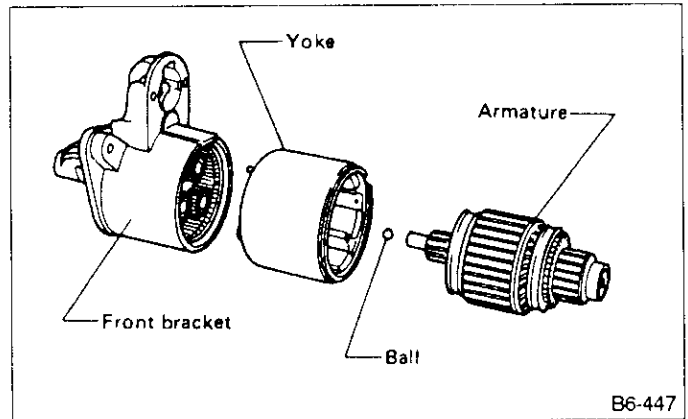


Fig. 50

- 5) Remove packing A, three planetary gears, packing B and plate.

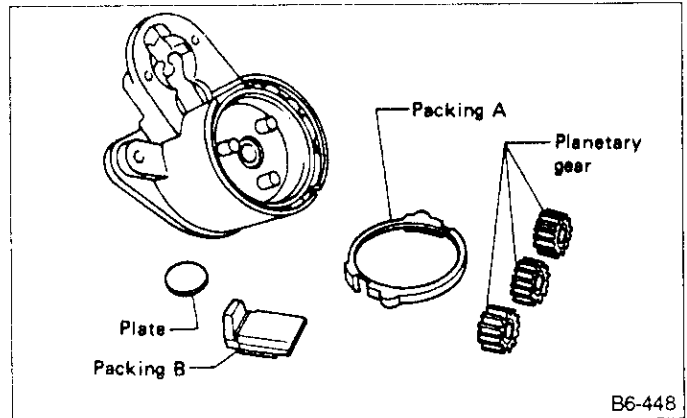


Fig. 51

- 6) Remove shaft ASSY and overrunning clutch as a unit.

Record the direction of lever before removing.

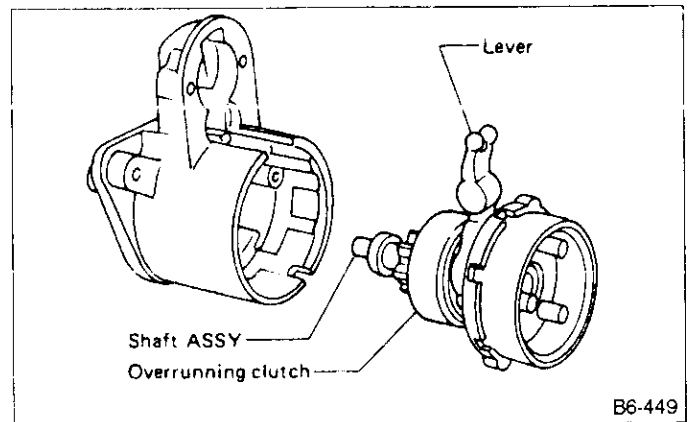


Fig. 52

- 7) Remove overrunning clutch from shaft ASSY as follows:

- (1) Remove stopper from ring by lightly tapping a jig placed on stopper.
- (2) Remove ring, stopper and clutch from shaft.

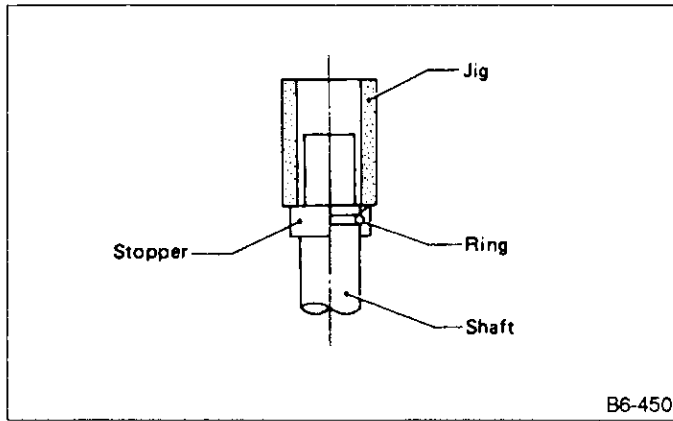


Fig. 53

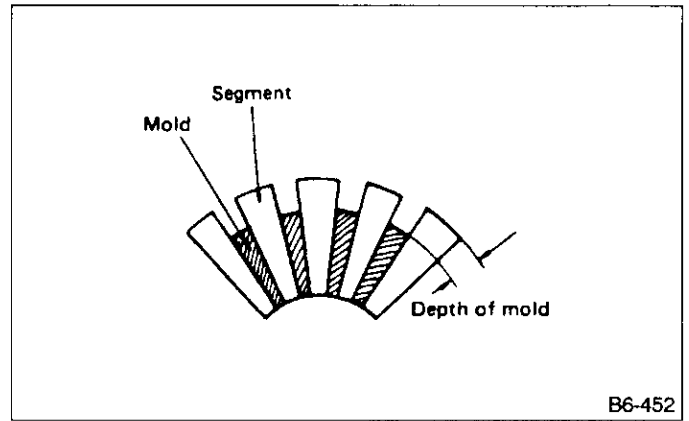


Fig. 55

C: INSPECTION

1. ARMATURE

- 1) Check commutator for any sign of burns or rough surfaces or stepped wear. If wear is of a minor nature, correct it by using sandpaper.
- 2) Run-out test
Check the commutator run-out and replace if it exceeds the limit.

Commutator run-out:

Standard

0.05 mm (0.0020 in)

Service limit

Less than 0.10 mm (0.0039 in)

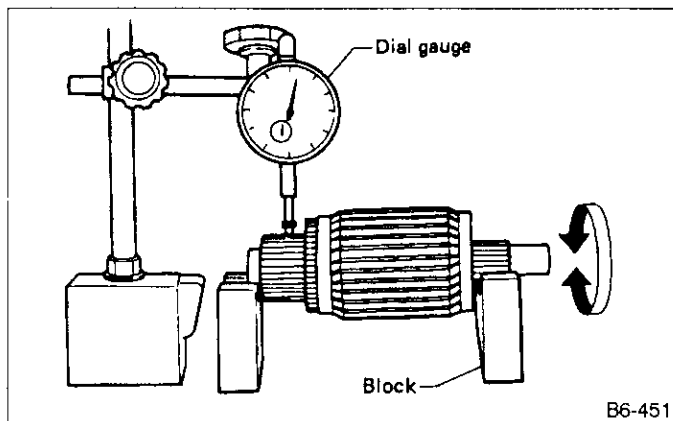


Fig. 54

- 3) Depth of segment mold
Check the depth of segment mold.

Depth of segment mold:

0.5 — 0.8 mm (0.020 — 0.031 in)

4) Armature short-circuit test

Check armature for short-circuit by placing it on growler tester. Hold a hacksaw blade against armature core while slowly rotating armature. A short-circuited armature will cause the blade to vibrate and to be attracted to core. If the hacksaw blade is attracted or vibrates, the armature, which is short-circuited, must be replaced or repaired.

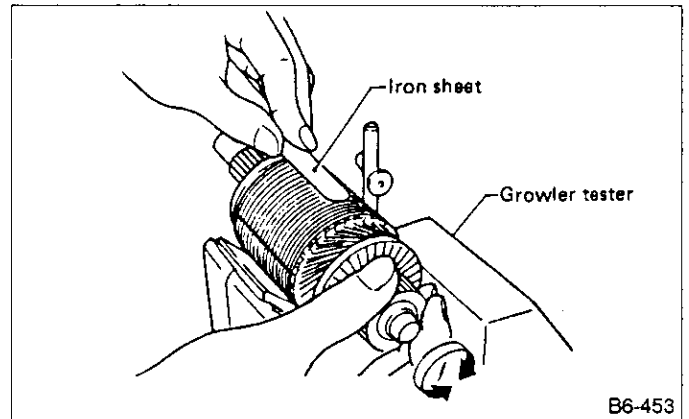


Fig. 56

5) Armature ground test

Using circuit tester, touch one probe to the commutator segment and the other to shaft. There should be no continuity. If there is a continuity, armature is grounded. Replace armature if it is grounded.

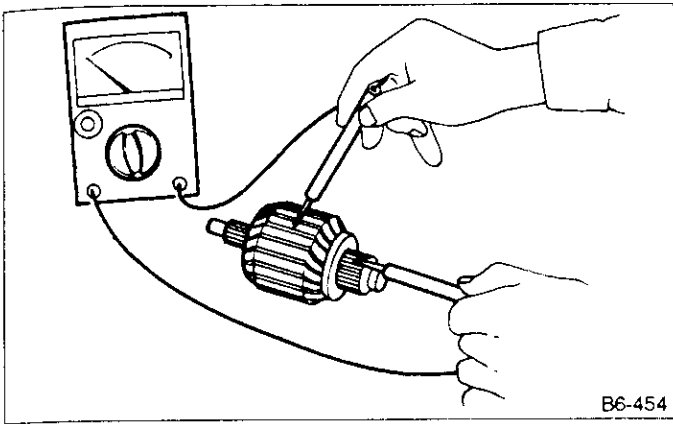


Fig. 57

2. YOKE

Make sure pole is set in position.

3. OVERRUNNING CLUTCH

Inspect teeth of pinion for wear and damage. Replace if it damaged. Rotate pinion in direction of rotation. It should rotate smoothly. But in opposite direction, it should be locked.

Do not clean overrunning clutch with oil to prevent grease from flowing out.

4. BRUSH AND BRUSH HOLDER

1) Brush length
Measure the brush length and replace if it exceeds the service limit.
Replace if abnormal wear or cracks are noticed.

Brush length:

Standard	17.5 mm (0.689 in)
Service limit	12.0 mm (0.472 in)

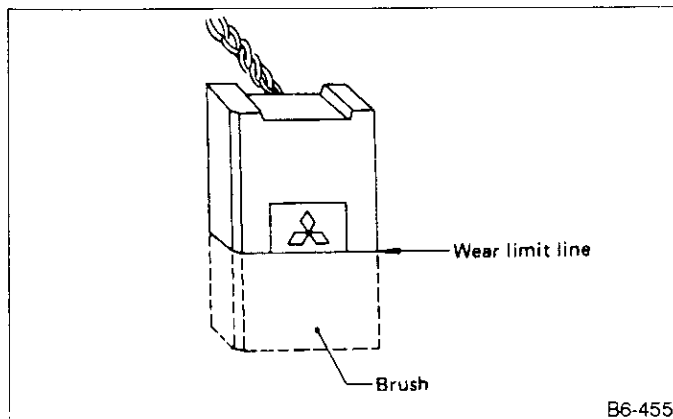


Fig. 58

- 2) Brush movement
Be sure brush moves smoothly inside brush holder.
- 3) Insulation of brush holder

Be sure there is no continuity between brush holder and its plate.

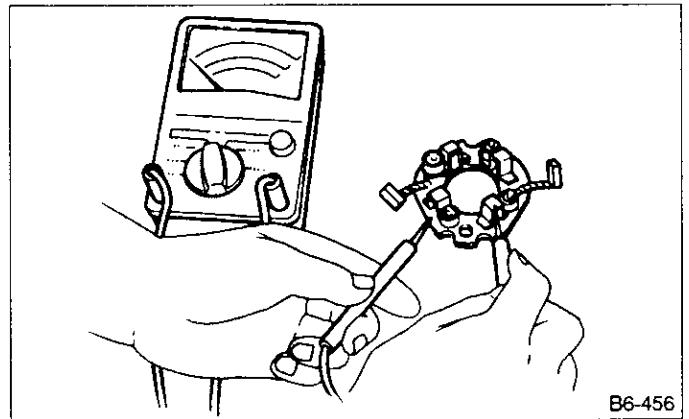


Fig. 59

4) Brush spring force
Measure brush spring force with a spring scale. If it is less than the service limit, replace brush spring.

Brush spring force:

Standard

- MIT70381A, MIT77181
20.6 N (2.1 kg, 4.6 lb) (when new)
- MIT75681
24.5 N (2.5 kg, 5.5 lb) (when new)

Service limit

- MIT70381, MIT77181
6.9 N (0.7 kg, 1.5 lb)
- MIT75681
9.32 N (0.95 kg, 2.09 lb)

5. SWITCH ASSEMBLY

Be sure there is continuity between terminals S and M, and between terminal S and body ground. Use a circuit tester (set in "ohm"). Also check to be sure there is no continuity between terminal M and B.

Terminal	
S — M	Continuity
S — Body ground	Continuity
M — B	No continuity

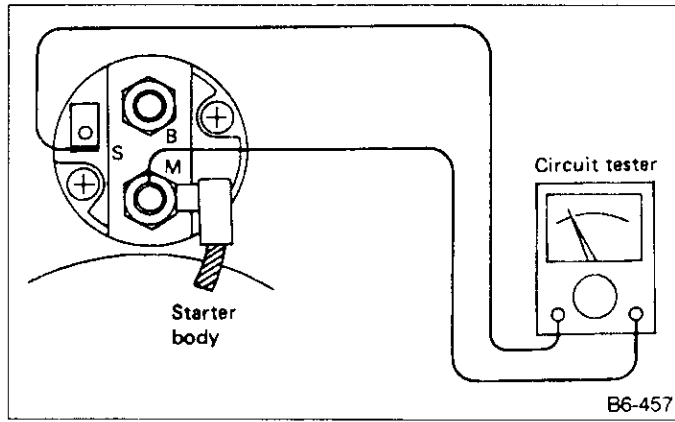


Fig. 60

B6-457

D: ASSEMBLY

Assembly is in the reverse order of disassembly procedures. Observe the following:

- 1) Carefully assemble all parts in the order of assembly and occasionally inspect nothing has been overlooked.
- 2) Apply grease to the following parts during assembly.
 - Front and rear bracket sleeve bearings
 - Armature shaft gear
 - Outer periphery of plunger
 - Mating surface of plunger and lever

- Gear shaft splines
- Mating surface of lever and clutch
- Ball at the armature shaft end
- Internal and planetary gears

3) After assembling parts correctly, check to be sure starter operates properly.

3. Alternator (HITACHI)

A: TEST

1. PRECAUTION

Prepare the following measuring equipment:

- (1) DC voltmeter (V): 0 — 30 V
- (2) DC ammeter (A): 0 — 100 A
- (3) Variable resistor: 0.15 — 0.45 Ω, 1 kW
- (4) Switch (SW1 and SW2): 12 V
- (5) Test lamp: 12 V, 1.4 W

- Connect test leads [of at least 8 mm² (0.012 sq in) in cross-sectional area and shorter than 2.5 m (8.2 ft)] in line "Y" (between alternator B terminal and battery positive terminal), and in line "Z" (between battery negative terminal and terminal E).
- Use switches SW1 and SW2 having as low a resistance as possible.

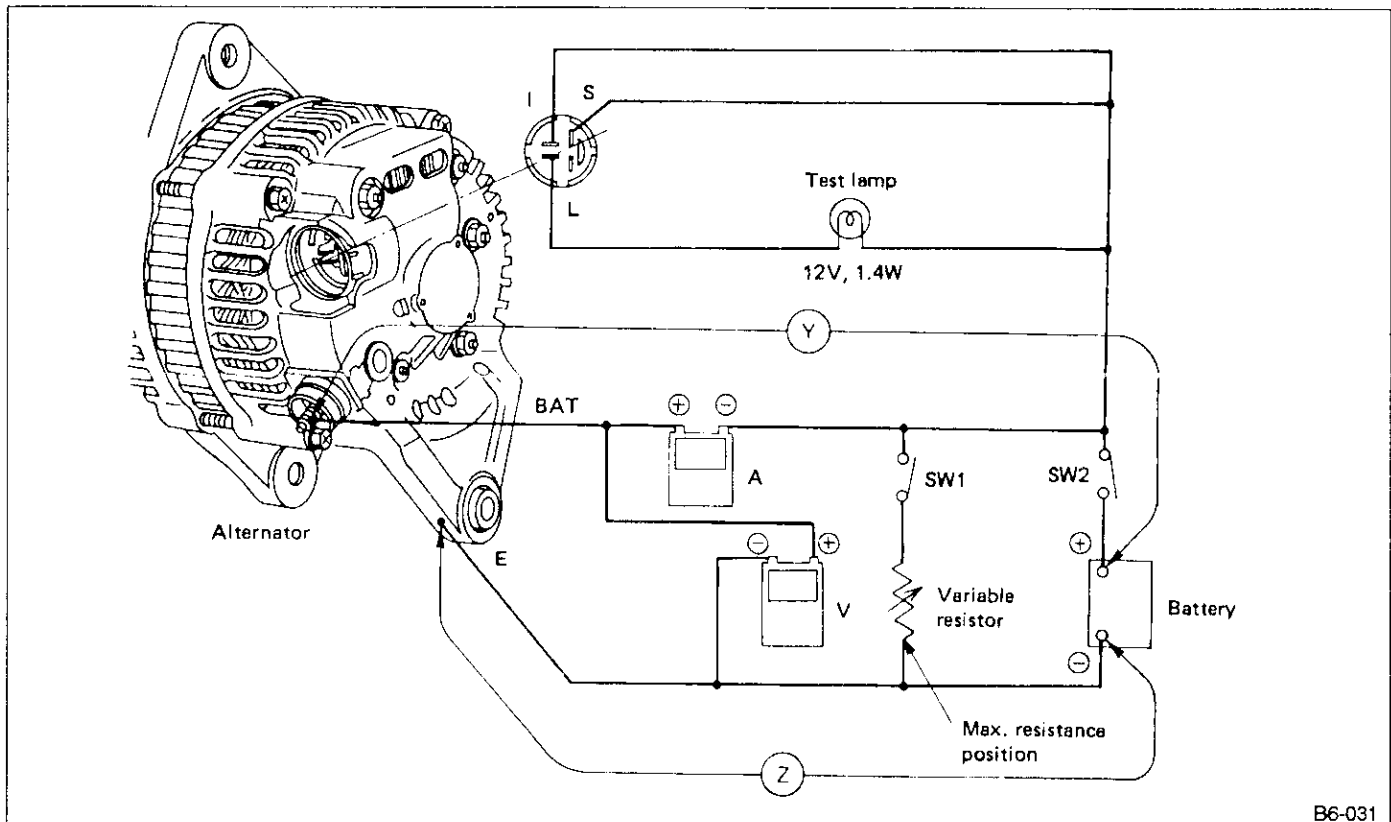


Fig. 61

B6-031

2. REGULATING VOLTAGE MEASUREMENT

- 1) Open switch SW1 and close switch SW2.
- 2) Operate alternator at a rated speed of 6,000 rpm.
- 3) Measure regulating voltage (while operating at 6,000 rpm). If it is in the 14.1 to 14.8 V range, alternator is functioning properly.

3. OUTPUT CURRENT MEASUREMENT

- 1) Set variable resistor at maximum resistance position. Close both SW1 and SW2.
- 2) While adjusting variable resistor, increase alternator speed so that voltmeter registers 13.5 volts.
- 3) Measure output current values when alternator speeds reach 1,500, 3,000 and 6,000 rpm, respectively.

1,500 rpm	Greater than 33 A
3,000 rpm	Greater than 66 A
6,000 rpm	Greater than 80 A

4. ALTERNATOR SPEED AT 13.5 V

- 1) Open switch SW1, and close switch SW2. Gradually raise alternator speed, and read the speed when the voltage is 13.5 V.
- 2) The alternator is normal if it is turning at less than 1,000 rpm when the voltage is 13.5 V.

B: DISASSEMBLY

- 1) Remove through bolts from alternator. Detach front cover with rotor from rear cover with stator by lightly tapping on front cover with a plastic hammer.

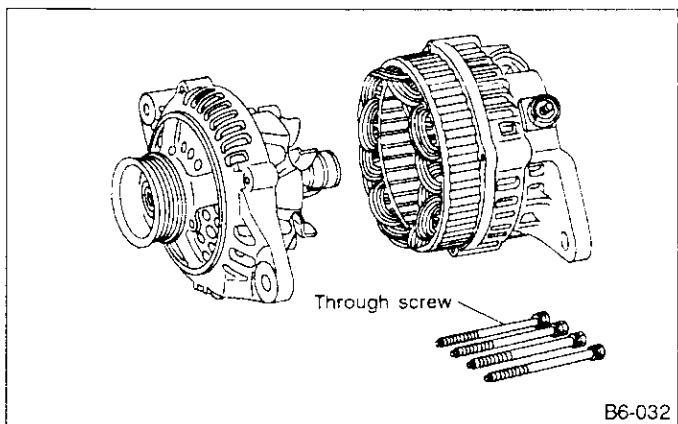


Fig. 62

- 2) Hold rotor with a vise and remove pulley nut.

When holding rotor with vise, insert aluminum plates on the contact surfaces of the vise to prevent rotor from damage.

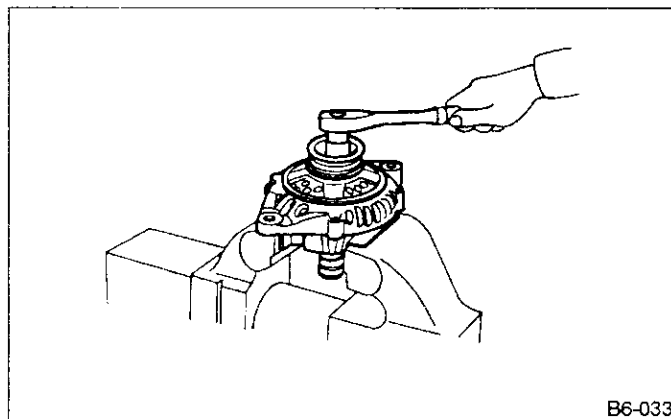


Fig. 63

- 3) Remove rotor from front cover.
- 4) Remove three screws from front cover and then bearing retainer and ball bearing.

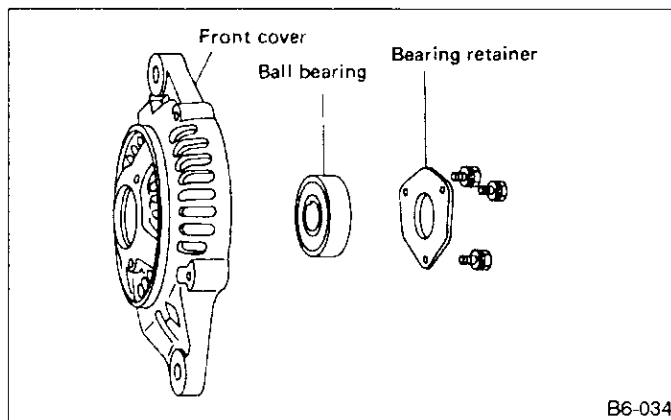


Fig. 64

- 5) Remove bolt which secure battery terminal bolt, and remove rear cover. Remove nuts which secure diode and IC regulator, and remove stator and rear cover.

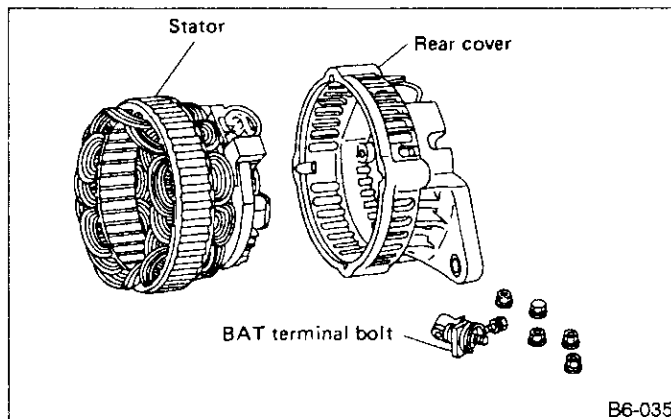


Fig. 65

6) Remove bolts which secure stator terminal to diode terminal, and remove stator.

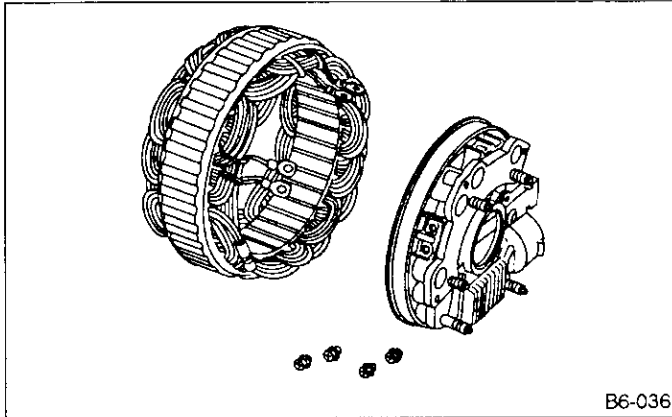


Fig. 66

7) Remove bolts which secure IC regulator ASSY, diode ASSY and brush holder, and separate these ASSY's.

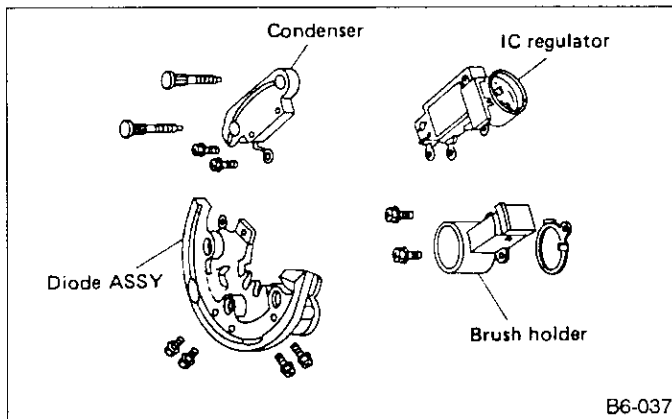


Fig. 67

Do not apply a shock or load to IC regulator cooling fins.

C: INSPECTION AND REPAIR

1. ROTOR

1) Slip ring surface

Inspect slip rings for contamination or any roughness of the sliding surface.

Clean or polish with #500 to #600 emery paper if defective.

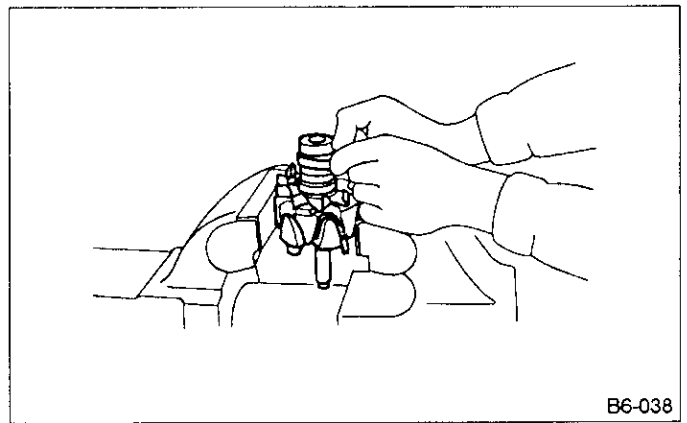


Fig. 68

2) Slip ring outside diameter
Measure slip ring outside diameter. If slip ring is worn, replace rotor ASSY.

Slip ring outside diameter:

Standard

27 mm (1.06 in)

Limit

26 mm (1.02 in)

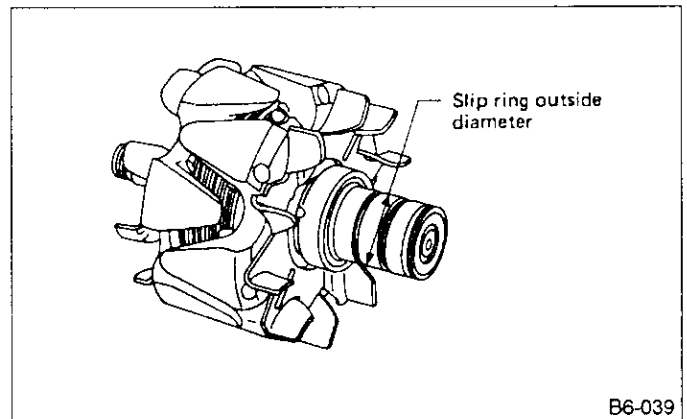


Fig. 69

3) Continuity test

Check continuity between slip rings. If continuity does not exist, replace rotor ASSY.

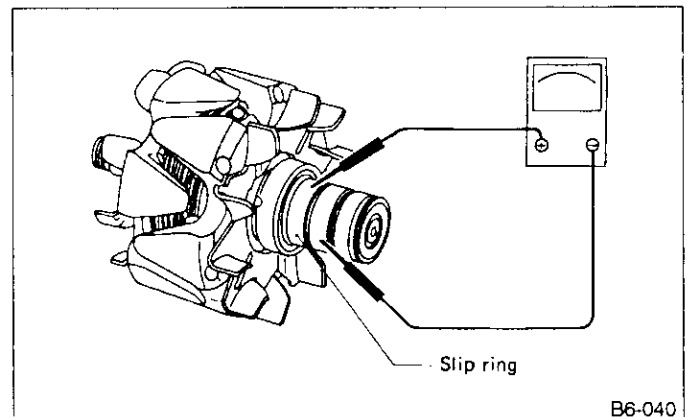


Fig. 70

4) Insulation test

Check continuity between slip ring and rotor core or shaft. If continuity exists, replace rotor ASSY.

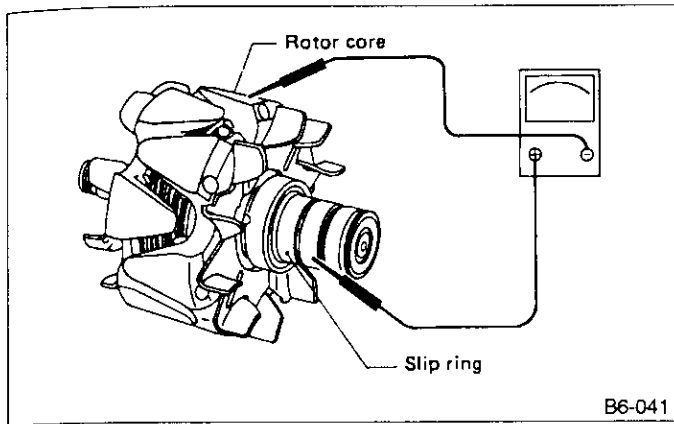


Fig. 71

5) Ball bearing

Check rear ball bearing. Replace if it is noisy or if rotor does not turn smoothly.

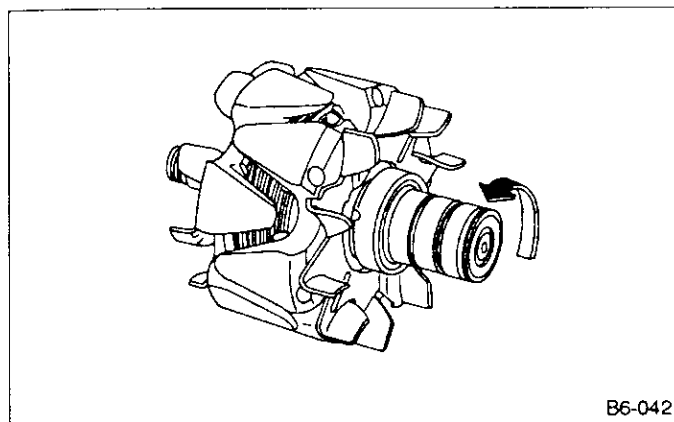


Fig. 72

2. STATOR

1) Continuity test

Inspect stator coil for continuity between its terminals. When there is no continuity between individual terminals, cable is broken. Replace stator ASSY.

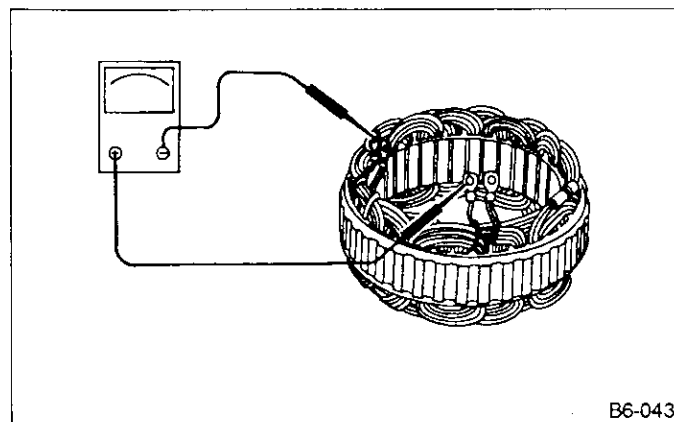


Fig. 73

2) Insulation test

Inspect stator coil for continuity between stator core and each terminal. If there is continuity, replace stator ASSY.

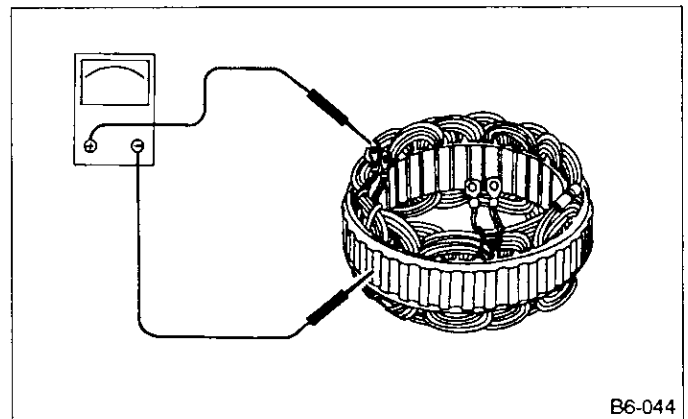


Fig. 74

3. BRUSH

Measure brush length. If brush is worn, replace brush holder ASSY.

Brush length (ℓ):

- Standard
25 mm (0.98 in)
- Limit
6 mm (0.24 in)

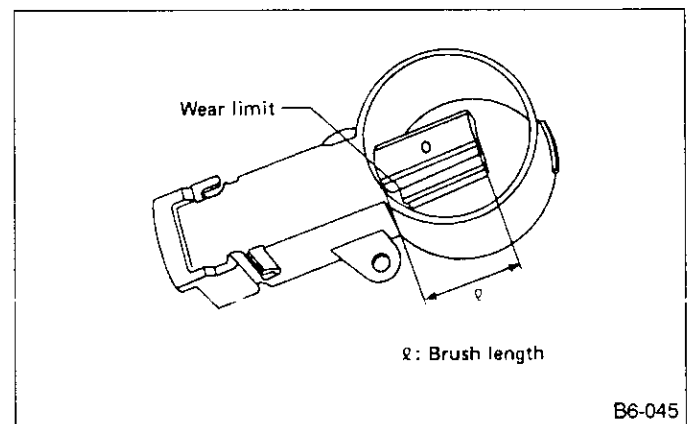


Fig. 75

4. DIODE ASSEMBLY

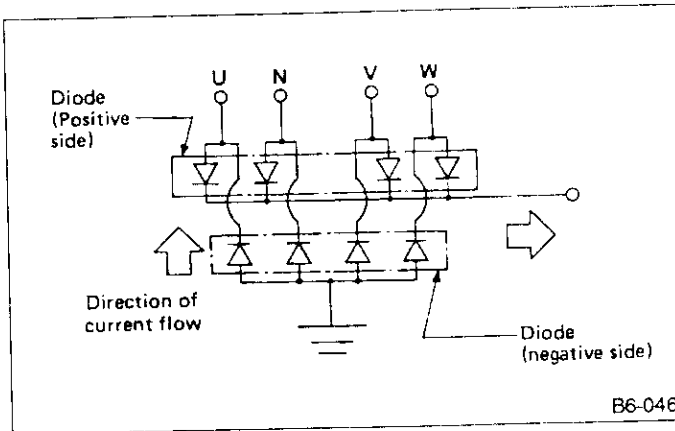


Fig. 76

The diode ASSY consists of eight diodes, four each being located on the positive and negative sides. The diode is necessary to restrict current flow to one direction.

Check all diodes, for continuity. If any diode is faulty, replace diode ASSY.

1) Diodes on "+" side

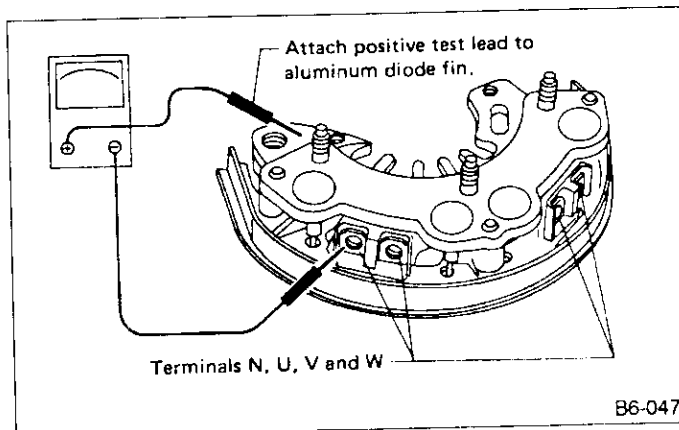


Fig. 77

Continuity of proper diodes on "+" side

	BAT side	(+)	(-)
Terminal N, U, V and W	(+)	—	Continuity must not exist.
	(-)	Continuity must exist.	—

2) Diodes on "-" side

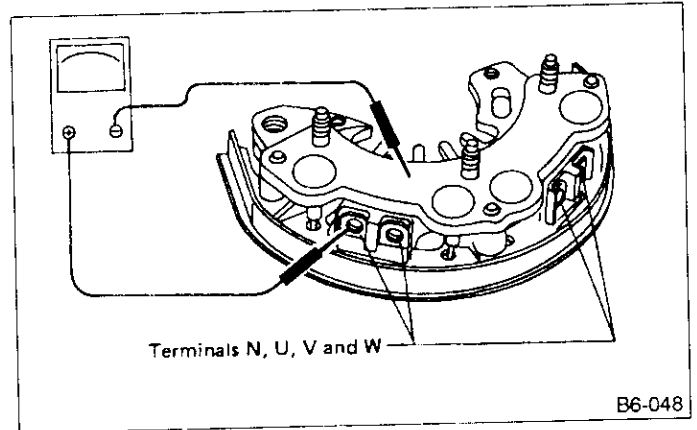


Fig. 78

Continuity of proper diodes on "-" side

	"E" side	(+)	(-)
Terminal N, U, V and W	(+)	—	Continuity must exist.
	(-)	Continuity must not exist.	—

Never use a high tension insulation tester, such as a meggar as it will damage diodes with its high tension.

5. IC REGULATOR

1) Prepare the following equipment:

- (1) Power supply: Variable 12 V DC
- (2) Lamp: L1 and L2, 12 V, 1.4 W, 2 each
- (3) Switch: SW1 and SW2, 12 V, 2 each
- (4) DC voltmeter (V): 0 — 50 V

2) Test procedure

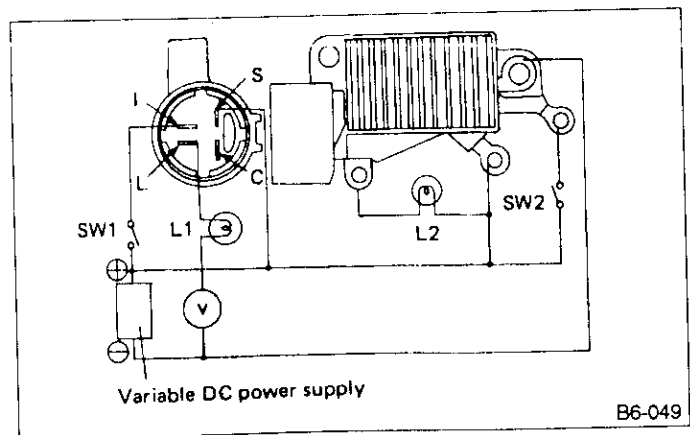


Fig. 79

- (1) Open switches SW1 and SW2.
- (2) Set variable DC power supply to 12 V.
- (3) Close switch SW1 to check L1 and L2 lamp conditions.

- (4) With switch SW1 closed, close switch SW2 to check L1 and L2.
- (5) With both switches closed, gradually increase variable DC power supply. Check L1 and L2 lamp conditions when power supply reaches the specified voltage range.

Specified voltage range [at 20°C (68°F)]:
14.1 — 14.8 V

Step No.	Lamp L1	Lamp L2
(3)	ON (bright)	On (dark)
(4)	OFF	ON (bright)
(5)	OFF	OFF

If any of the test results are not as indicated in the above table, replace IC regulator.

D: ASSEMBLY

To assemble, reverse order of disassembly procedures

- a. Install a new ball bearing on rear of alternator.
- b. Rear ball bearing has a ring placed in eccentric groove of the outer race. Part of this ring protrudes beyond the outer race. Before assembling the ring, rotate it so that the protrusion is reduced to a minimum. Replace rear cover if it is worn or damaged at bearing location.

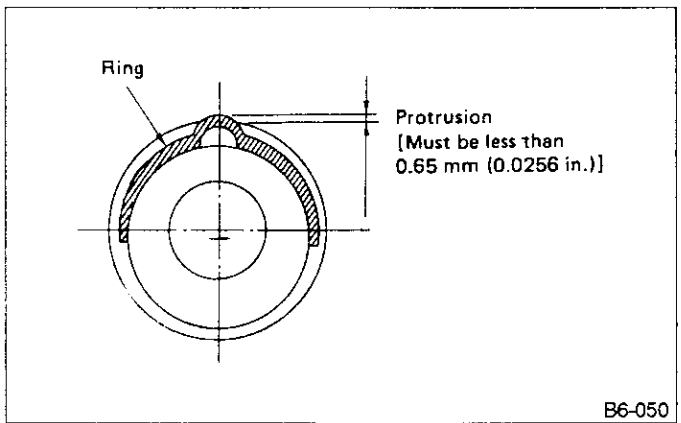


Fig. 80

- c. When installing front and rear covers, insert pin from outside of rear cover. Insert brush into brush holder. After cover installation, remove the pin.

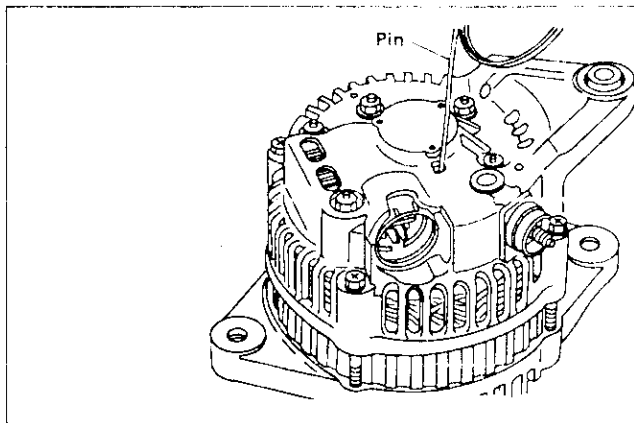
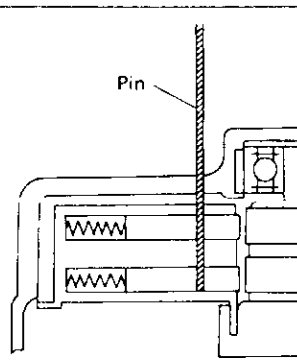


Fig. 81



B6-051

E: INSTALLATION

- 1) Install alternator to bracket on engine with bolts and tighten bolts lightly.
- 2) After installing drive belt, pull belt by moving alternator with adjusting bolt and tighten installing bolts.
- 3) Check belt tension.
- 4) Connect lead wires to alternator.

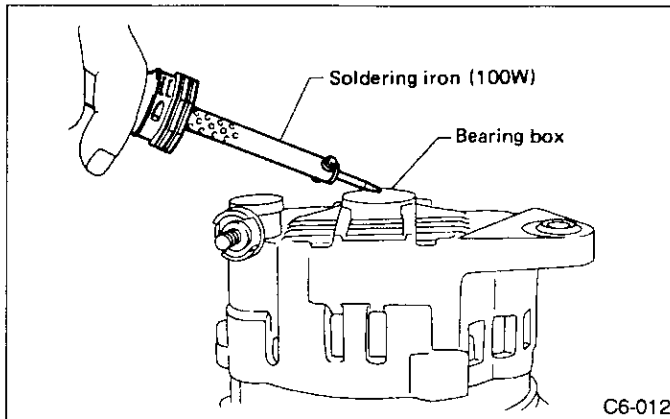
- a. Be careful not to connect individual terminals erroneously.
- b. Pay careful attention to battery polarity so that it may not be reversed by wrong connection. If polarities are reversed, battery will be shorted by diode, excessive current will flow, and diodes or wire harness may be damaged.

4. Alternator (MITSUBISHI)

A: DISASSEMBLY

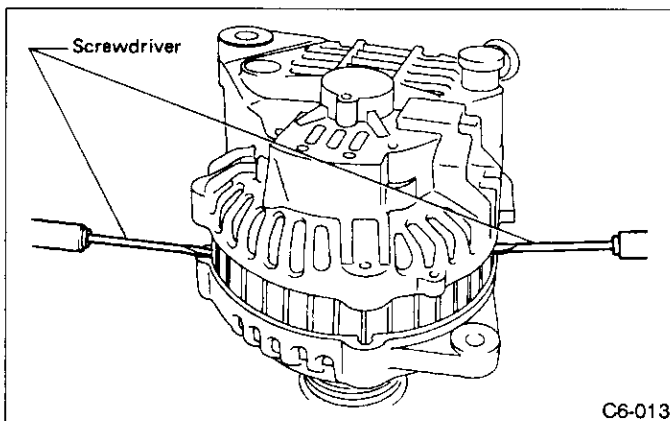
1) Heat the bearing box to 50 to 60°C (122 to 140°F) with a 100 W-soldering iron and remove the four through bolts. Then insert the tip of a flat-head screwdriver into the gap between the stator core and front bracket. Pry then apart to disassemble.

Be careful not to lose the spring fitted in the periphery of the rear bearing.



C6-012

Fig. 82

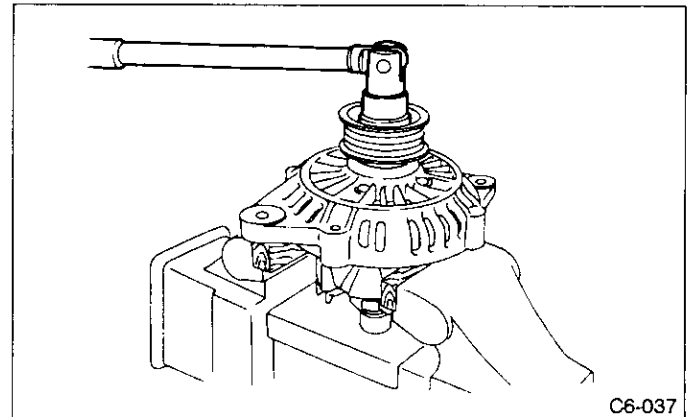


C6-013

Fig. 83

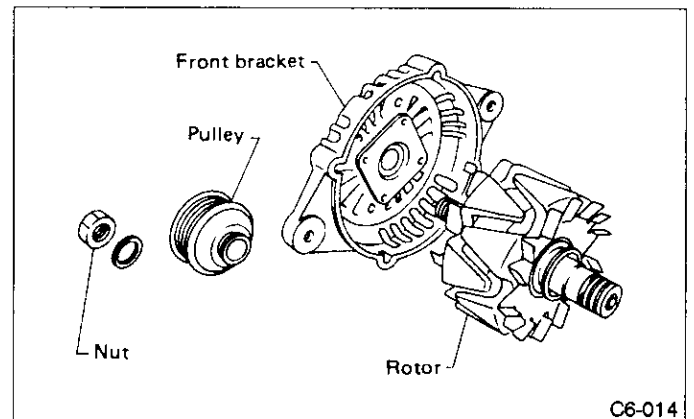
2) Hold rotor with a vise and remove pulley nut.

When holding rotor with vise, insert aluminum plates or wood pieces on the contact surfaces of the vise to prevent rotor from damage.



C6-037

Fig. 84

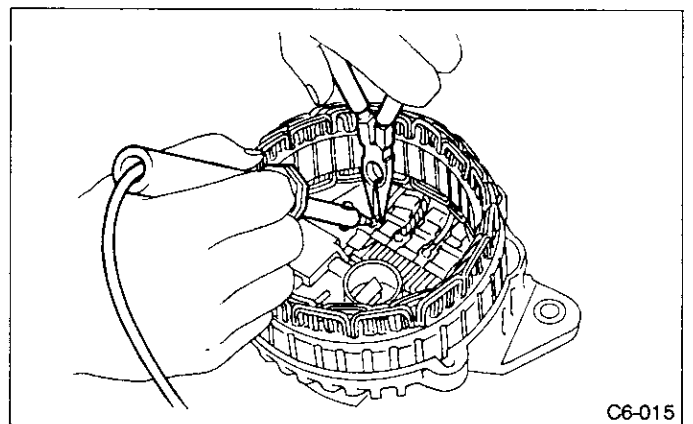


C6-014

Fig. 85

3) Unsolder connection between rectifier and stator coil to remove stator coil.

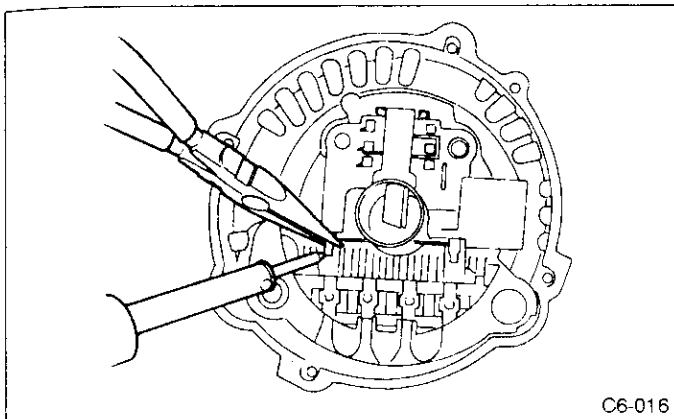
Finish the work rapidly (less than three seconds) because the rectifier cannot withstand heat very well.



C6-015

Fig. 86

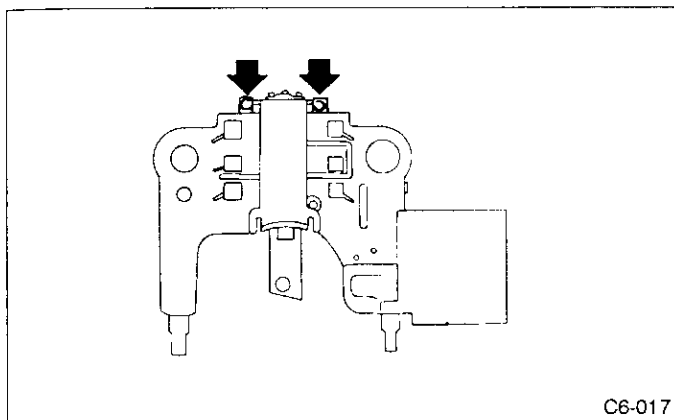
4) Remove screws which secure IC regulator to rear cover, and unsolder connection between IC regulator and rectifier to remove IC regulator.



C6-016

Fig. 87

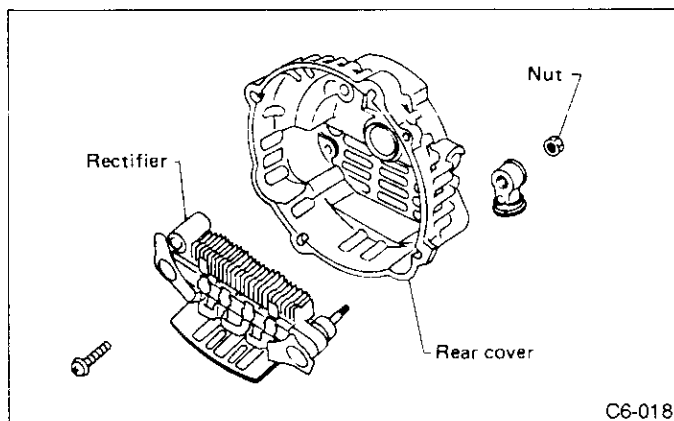
5) Remove the brushes by unsoldering at the pigtails.



C6-017

Fig. 88

6) Remove the nut and insulating bushing at terminal B. Remove rectifier.



C6-018

Fig. 89

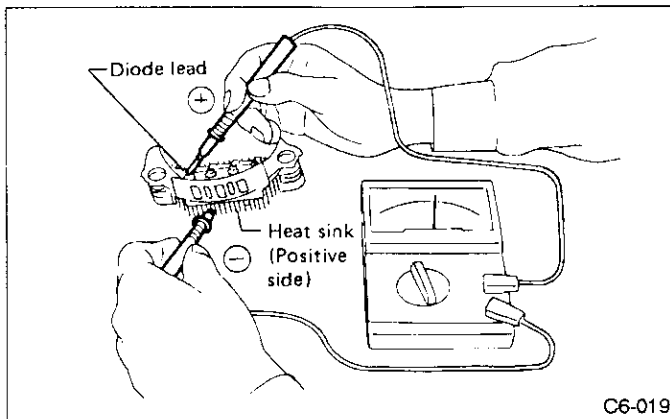
B: INSPECTION AND REPAIR

1. DIODE

Never use a megger tester (measuring use for high voltage) or any other similar measure for this test; otherwise, the diodes may be damaged.

1) Checking positive diode

Check for continuity between the diode lead and the positive side heat sink. The positive diode is in good condition if continuity exists only in the direction from the diode lead to the heat sink.

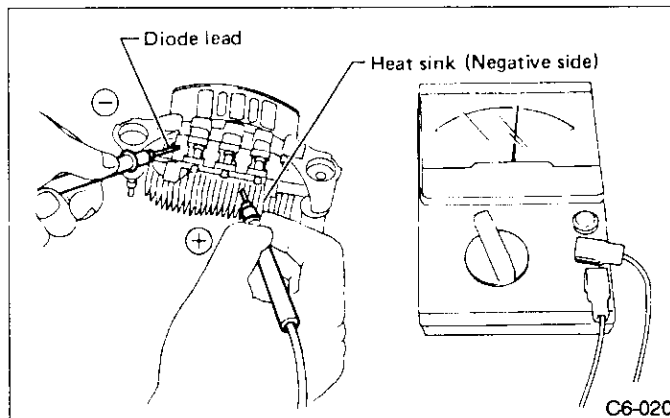


C6-019

Fig. 90

2) Checking negative diode

Check for continuity between the negative side heat sink and diode lead. The negative diode is in good condition if continuity exists only in the direction from the heat sink to the diode lead.



C6-020

Fig. 91

3) Checking trio diode

Check the trio diode using a circuit tester. It is in good condition if continuity exists only in one direction.

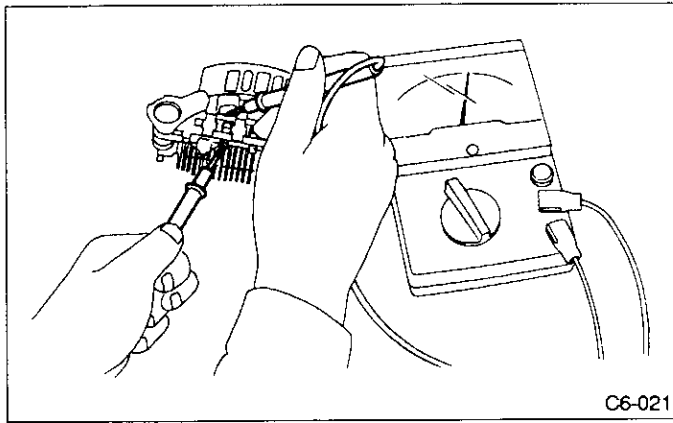


Fig. 92

2. ROTOR

1) Slip ring surface

Inspect slip rings for contamination or any roughness of the sliding surface. Repair slip ring surface using a lathe or sandpaper.

2) Slip ring outer diameter

Measure slip ring outer diameter. If slip ring is worn replace rotor ASSY.

Slip ring outer diameter:

Standard

22.7 mm (0.894 in)

Limit

22.1 mm (0.870 in)

3) Continuity test

Check resistance between slip rings using circuit tester. If the resistance is not within specification, replace rotor ASSY.

Specified resistance:

Approx. 3 Ω

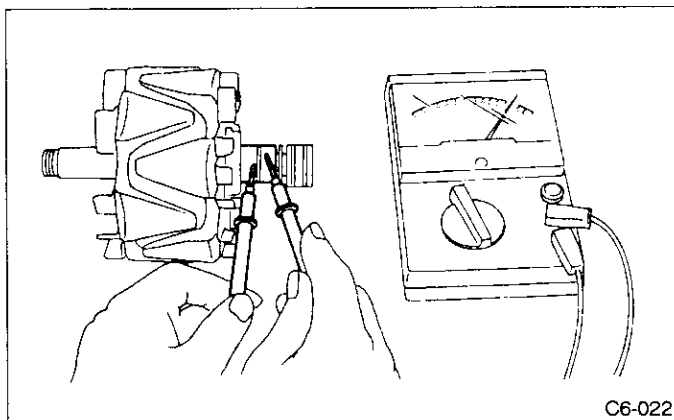


Fig. 93

4) Insulation test

Check continuity between slip ring and rotor core or shaft. If continuity exists, the rotor coil is short-circuited, and so replace rotor ASSY.

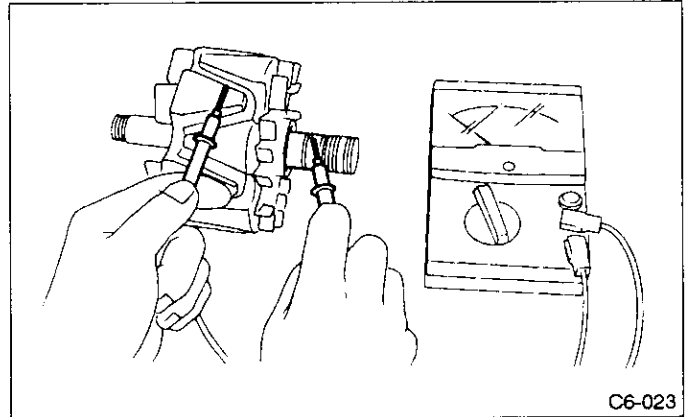


Fig. 94

5) Ball bearing (rear side)

(1) Check rear ball bearing. Replace it if it is noisy or if rotor does not turn smoothly.

(2) The rear bearing can be removed by using common bearing puller.

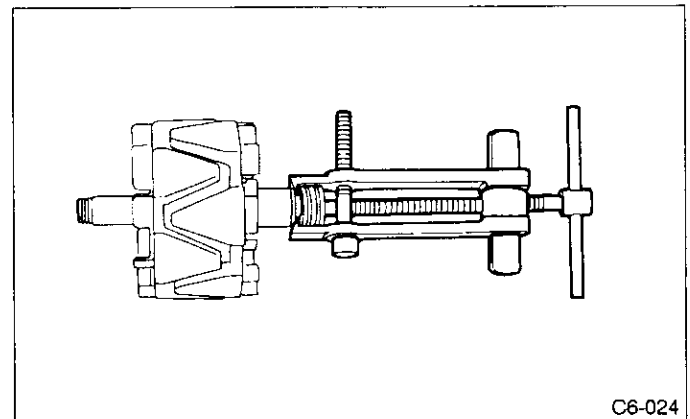


Fig. 95

3. STATOR

1) Continuity test

Inspect stator coil for continuity between each end of the lead wires. If there is no continuity between individual lead wires, the lead wire is broken, and so replace stator ASSY.

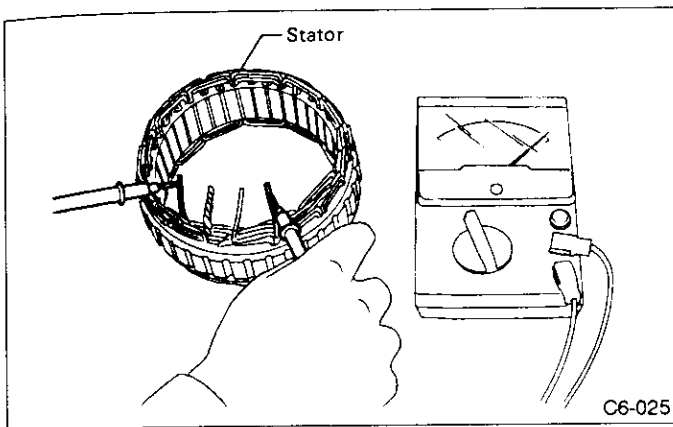


Fig. 96

2) Insulation test

Inspect stator coil for continuity between stator core and each end of the lead wire. If there is continuity, the stator coil is short-circuited, and so replace stator ASSY.

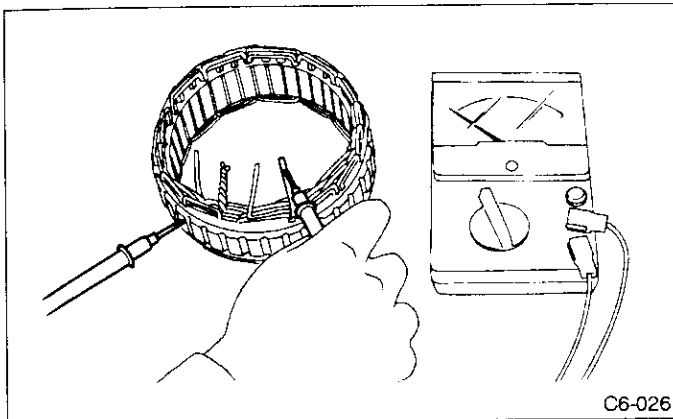


Fig. 97

4. BRUSH

1) Measure the length of each brush. If wear exceeds the wear limit, replace the brush. Each brush has the wear limit mark on it.

Brush length:

Standard

21.5 mm (0.846 in)

Wear limit

8.0 mm (0.315 in)

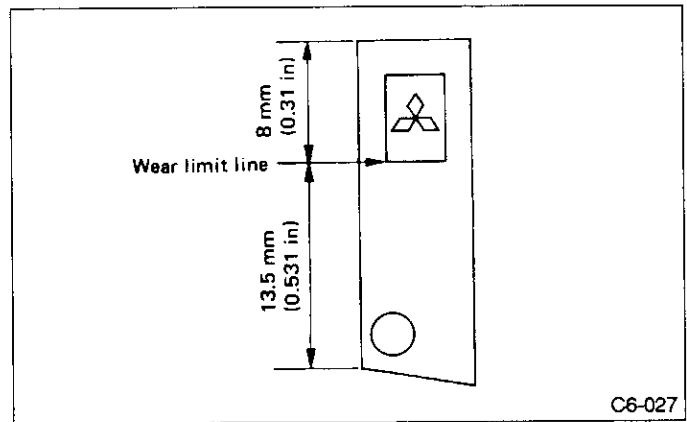


Fig. 98

2) Checking brush spring for proper pressure

Using a spring pressure indicator, push the brush into the brush holder until its tip protrudes 2 mm (0.08 in). Then measure the pressure of the brush spring. If the pressure is less than 1.765 N (180 g, 6.35 oz), replace the brush spring. The new spring must have a pressure of 3.334 to 4.119 N (340 to 420 g, 11.99 to 14.81 oz).

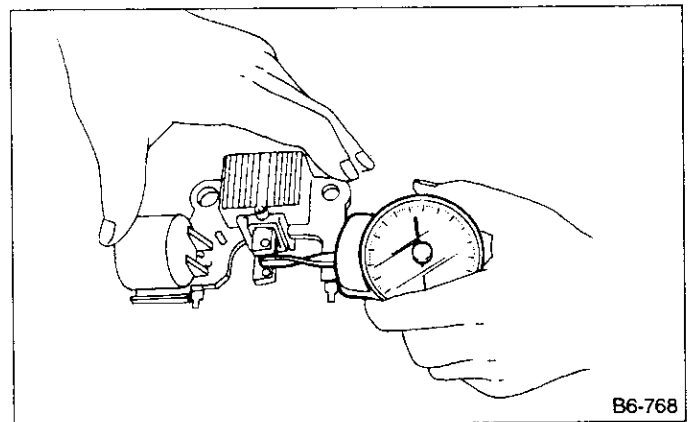


Fig. 99

5. BEARING (front side)

1) Check front ball bearing. If resistance is felt while rotating, or if abnormal noise is heard, replace the ball bearing.

2) Replacing front bearing

(1) Remove front bearing retainer.

(2) Closely install a fit jig on the bearing inner race. Press the bearing down out of front bracket with a hand press or vise. A socket wrench can serve as the jig.

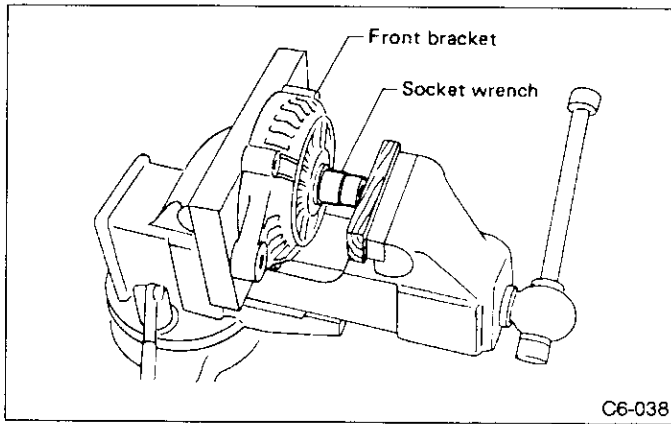


Fig. 100

(3) Set a new bearing and closely install a fit jig on the bearing outer race. Press the bearing down into place with a hand press or vise. A socket wrench can serve as the jig.

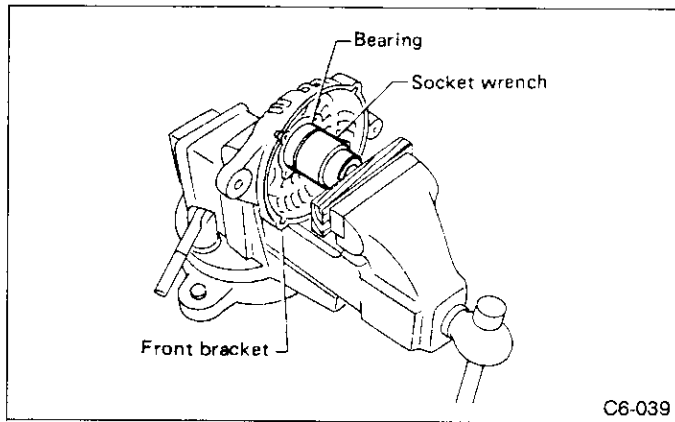


Fig. 101

(4) Install front bearing retainer.

C: ASSEMBLY

To assemble, reverse order of disassembly.

1) The rear bearing has an eccentric groove on its periphery. Fit the lock spring into this groove so that the projecting part is in the deepest portion of the groove. This will reduce spring projection, making reassembly easy. Also, it assures greater locking effect, since the spring will be free from undue force during reassembly. The deepest portion of the groove has chamfered edges for easy identification.

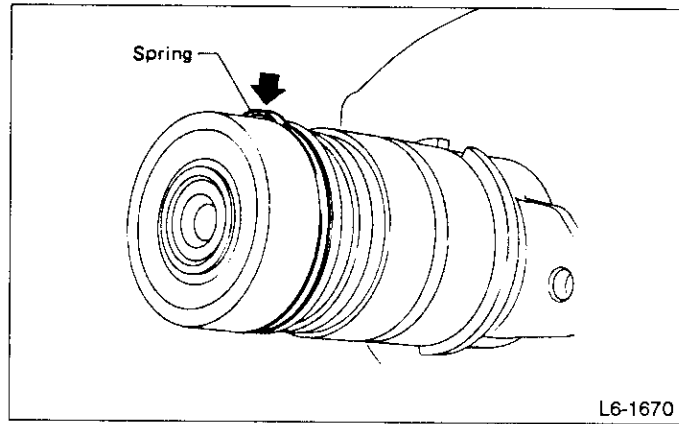


Fig. 102

2) Pulling up brush

Before assembling, press the brush down into the brush holder with your finger and secure in that position by passing a [2 mm (0.08 in) dia. length 4 to 5 cm (1.6 to 2.0 in)] wire through the hole shown in the figure.

Be sure to remove the wire after reassembly.

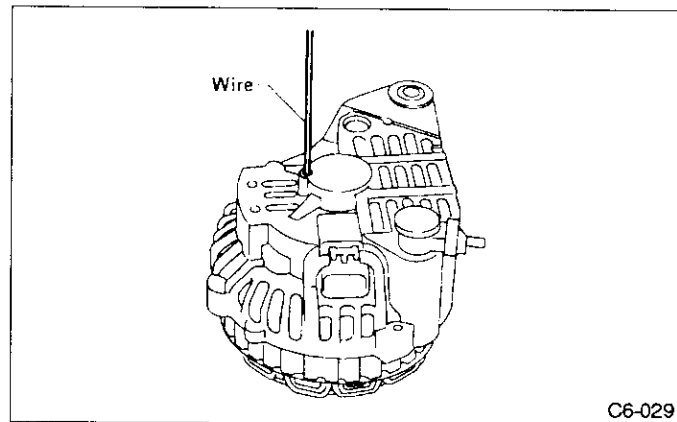


Fig. 103

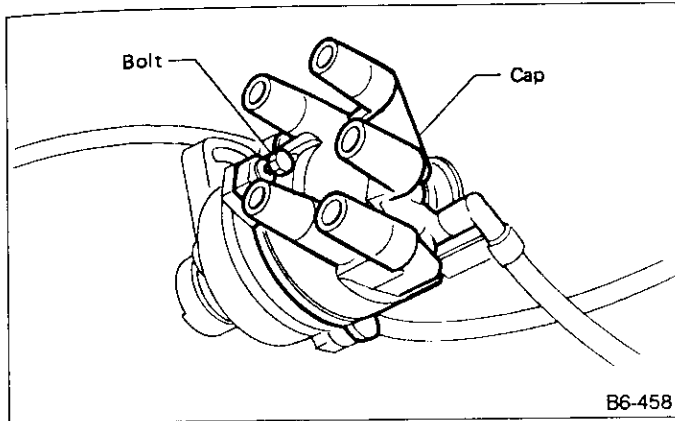
3) Heat the rear bracket [50 to 60°C (122 to 140°F)] and press the rear bearing into the rear bracket. Then lubricate the rear bracket.

4) After reassembly, turn the pulley by hand to check that the rotor turns smoothly.

5. Distributor

A: DISASSEMBLY

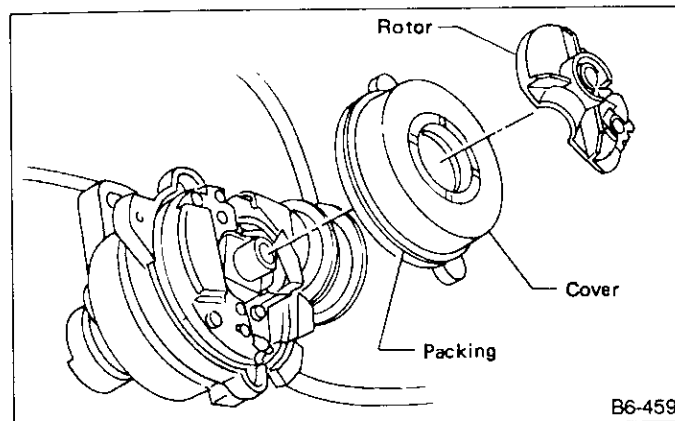
- 1) Remove bolts, then remove distributor cap.



B6-458

Fig. 104

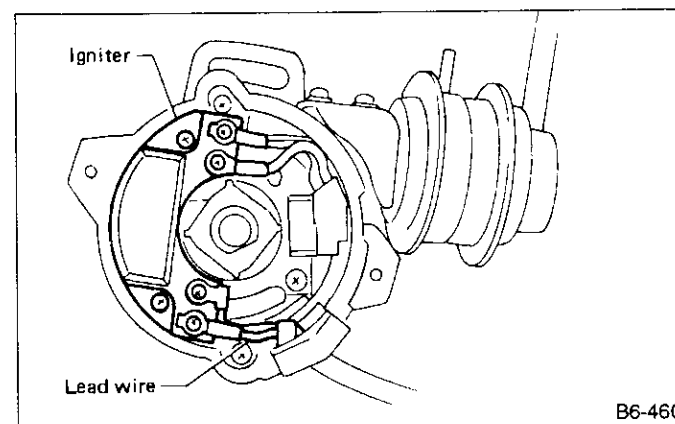
- 2) Remove the rotor.



B6-459

Fig. 105

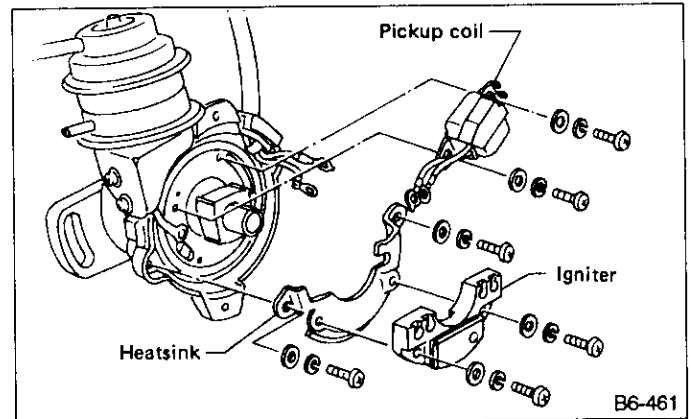
- 3) Remove the cover with packing.
4) Disconnect leads from igniter.



B6-460

Fig. 106

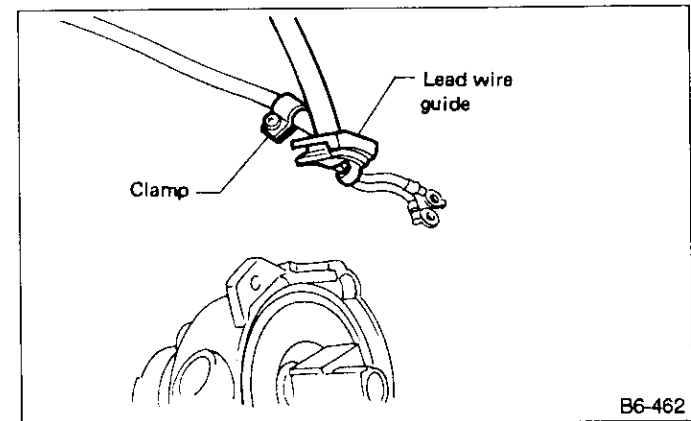
- 5) Remove pickup coil and leads as a unit.



B6-461

Fig. 107

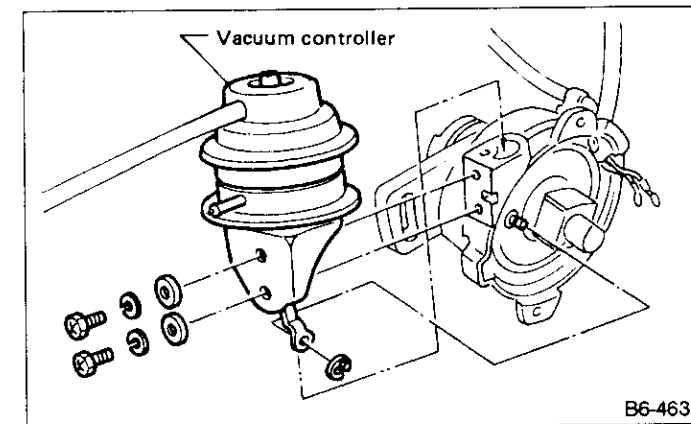
- 6) Remove igniter.
7) Remove heatsink.
8) Loosen screw securing electric wiring, and remove lead wire guide and clamp.



B6-462

Fig. 108

- 9) Remove the snap ring and screw, and extract vacuum controller.



B6-463

Fig. 109

10) Remove signal rotor and breaker plate.

(1) Align groove (on engine side) with alignment mark.

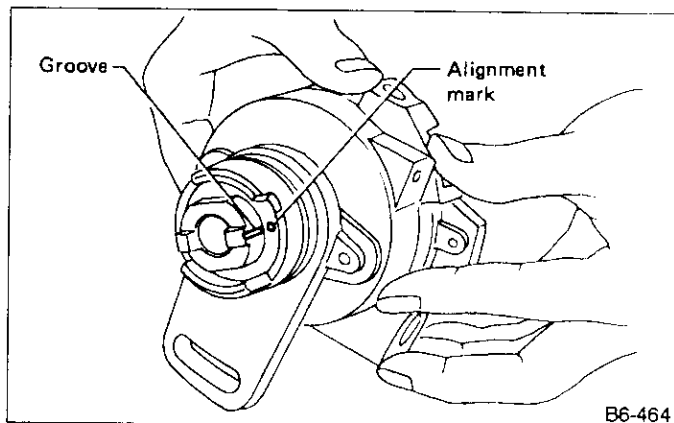


Fig. 110

(2) Record location of cutout portion at the end of signal rotor before removing signal rotor.

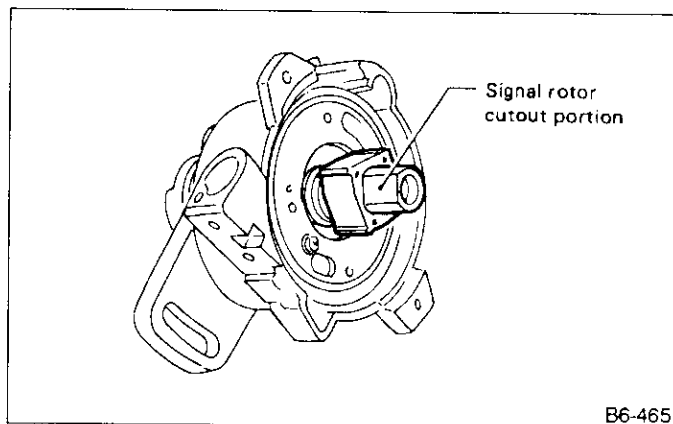


Fig. 111

Incorrect ignition timing will be set if governor shaft and signal rotor are not placed in the specified position during reassembly.

(3) Loosen bolt, and remove signal rotor and breaker plate.

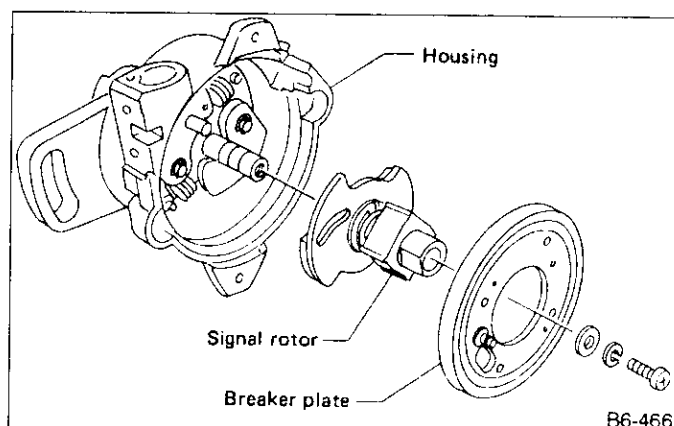


Fig. 112

11) Unhook governor springs with long-nosed pliers, and remove snap rings.

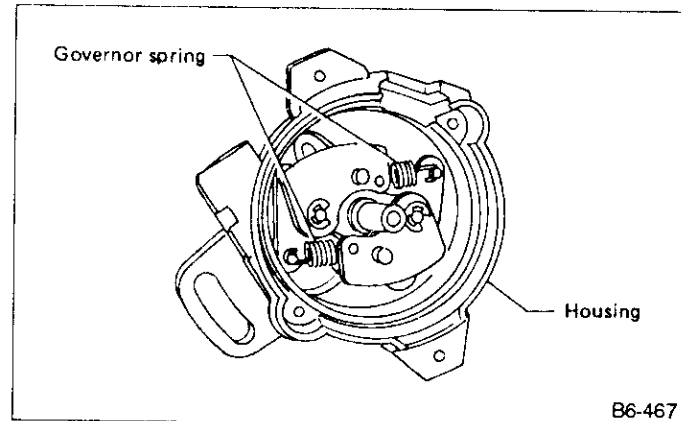


Fig. 113

a. Be careful not to damage springs and hooks.
b. Do not disassemble governor ASSY unless necessary.

B: INSPECTION

1. CAP

- 1) Carbon point for wear and operation
- 2) Terminals for wear and evidence of corrosion

2. ROTOR HEAD

- 1) For deformation and corrosion

3. GOVERNOR SPRING

- 1) For damage, rust, permanent set

4. GOVERNOR WEIGHT

- 1) For damage, deformation, and rust

5. VACUUM CONTROLLER

- 1) Apply vacuum pressure using a vacuum pump and check for leakage.

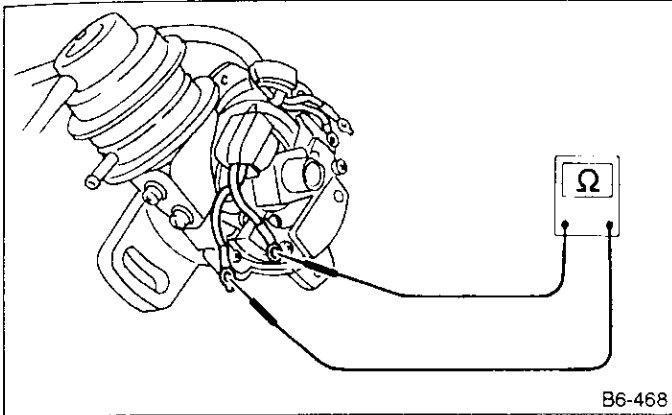
6. LEAD WIRE

- 1) Lead wire sheathing for cracks, and terminals for corrosion

7. INSPECTION OF PICKUP COIL

Disconnect G and R leads from igniter, and measure resistance between the two leads.

Specified resistance:
420 — 540 Ω

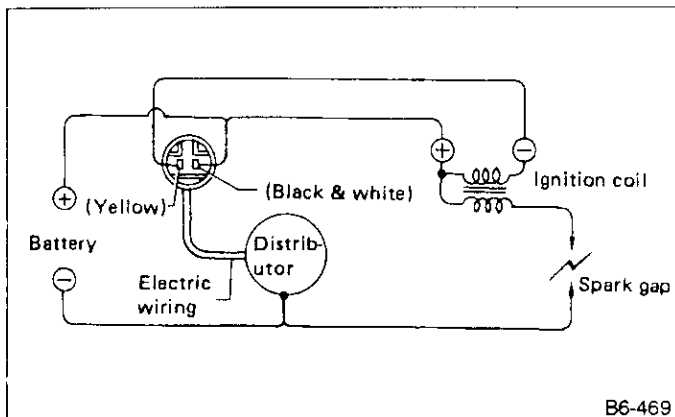


B6-468

Fig. 114

8. INSPECTION OF IGNITER

Set up igniter as shown in Figure 115. Hand-rotate distributor shaft with your hand to check that sparks occur. If no sparks occur, replace igniter.



B6-469

Fig. 115

This check should be conducted after pickup coil and air gap have been checked. (Refer to "Assembly".)

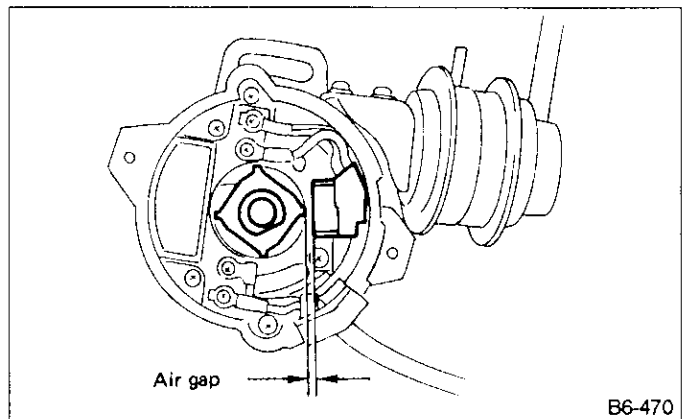
C: ASSEMBLY

Assembly is in the reverse order of disassembly. Observe the following:

- 1) Apply a coat of grease to:
 - (1) Signal rotor head (at bolt location)
 - (2) Sliding surface of breaker plate
- 2) Governor spring
Governor spring can be attached to either hook pin.
- 3) Install signal rotor while aligning its cutout portion with the original point before alignment is made.
- 4) After installing vacuum controller, install igniter and pickup coil.
- 5) Connect lead wires to their proper positions.
- 6) Air gap
After properly assembling parts, measure air gap between signal rotor and pickup coil with a thickness gauge.

Specified air gap:

More than 0.25 mm (0.0098 in)



B6-470

Fig. 116

If necessary, adjust the air gap.

6. Ignition Coil

A: REMOVAL AND INSPECTION

1. EXCEPT TURBO MODEL

- 1) Remove spark plug cord, distributor cord and connector from ignition coil.
- 2) Using accurate tester, inspect the following items, and replace if defective.
 - (1) Primary resistance
 - (2) Secondary coil resistance

If the resistance is extremely low, this indicates the presence of a short-circuit.

[MPFI]

Specified resistance:

[Primary side]

Between ① and ②

Between ③ and ④

0.63 — 0.77 Ω

[Secondary side]

Between terminal No. 1 and No. 2

Between terminal No. 3 and No. 4

10.4 — 15.6 k Ω

[Insulation resistance]

Between primary terminal and case

More than 10 M Ω

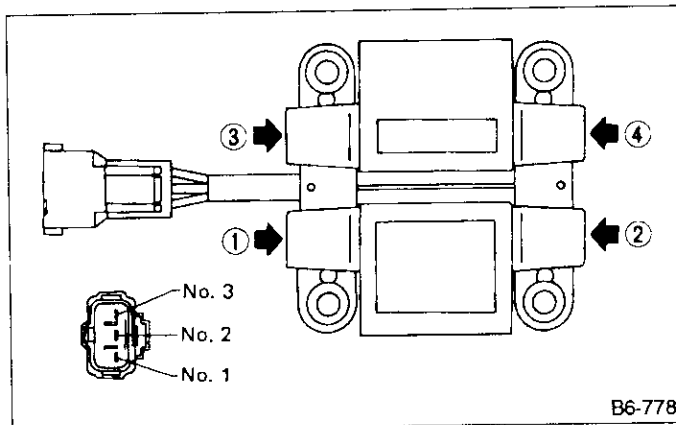


Fig. 117

[SPFI]

Specified resistance:

[Primary side]

Between terminal No. 2 and No. 3

0.81 — 0.99 Ω

[Secondary side]

Between terminal No. 2 and secondary terminal

8 — 12 k Ω

[Insulation resistance]

Between primary terminal and case

More than 10 M Ω

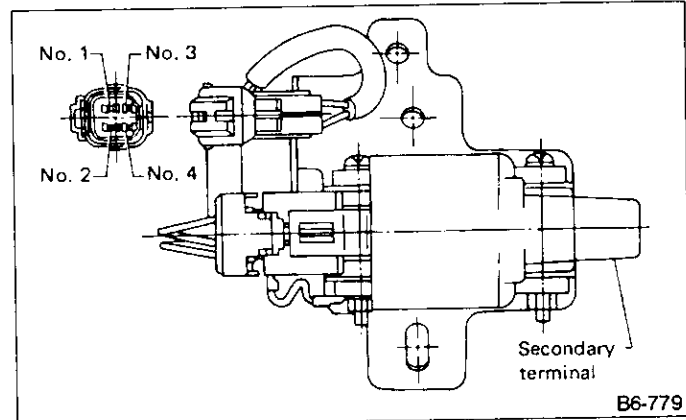


Fig. 118

[Carburetor]

Specified resistance:

[Primary side]

Between terminal No. 1 and No. 2

1.4 — 1.7 Ω

[Secondary side]

Between terminal No. 1 and secondary terminal

12.8 — 17.3 Ω

[Insulation resistance]

Between primary terminal and case

More than 10 M Ω

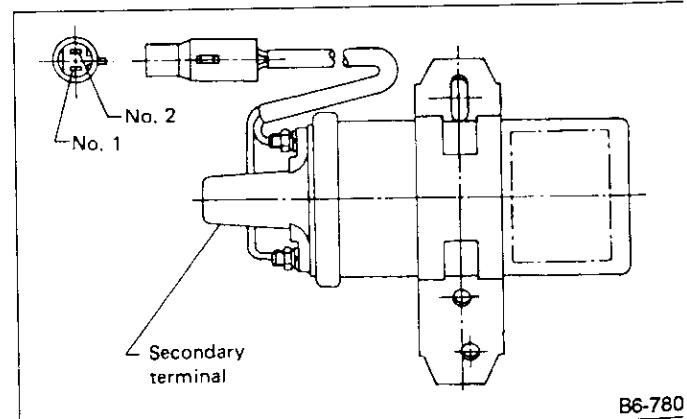


Fig. 119

2. TURBO MODEL

1) Removal of ignition coil (RH).

- (1) Dismount accelerator cable from clamps.
- (2) Remove air intake boot and air cleaner case.
- (3) Disconnect ignition coil harness connector.
- (4) Remove ignition coil.

2) Removal of ignition coil (LH).

- (1) Remove battery and window washer tank.
- (2) Disconnect ignition coil harness connector.
- (3) Remove ignition coil.

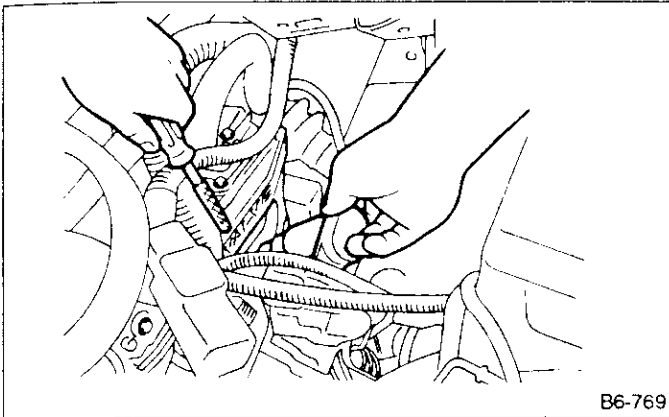


Fig. 120

3) Using accurate tester, measure the primary coil resistance.

If the resistance is extremely low, this indicates the presence of a short-circuit.

Specified resistance:

[Primary side]

Between terminal No. 1 and No. 2

0.68 — 0.83 Ω

[Insulation resistance]

Between primary terminal and case

More than 10 M Ω

4) Using digital ammeter, check the secondary coil.

Specified current value:

[Secondary side]

Approximately 0.32 mA

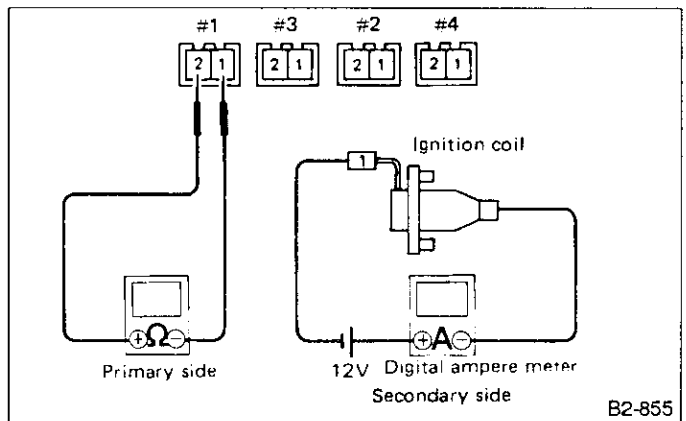


Fig. 121

5) If a digital ammeter is not available, use method described below.

- (1) Disconnect all fuel injector connectors.
- (2) Remove ignition coil to be checked from cylinder head.
- (3) Install good spark plug to ignition coil.
- (4) Make sure all ignition coil connectors except the one to be checked are disconnected.
- (5) Contact metal section of spark plug to cylinder head. Turn ignition switch to "START" to make sure spark occurs between spark plug electrodes.
- (6) If spark does not occur, check primary coil condition. If primary coil is satisfactory, secondary coil is faulty.

Before checking secondary coil using "spark" method described above, make sure the other ignition systems are in good condition. (Ref. to 2-7c [T6C0].)

6) Installation is in the reverse order of removal.

Tightening torque (Ignition coil):

4.4 — 5.4 N·m (0.45 — 0.55 kg·m, 3.3 — 4.0 ft·lb)

7. Spark Plug

A: DESCRIPTION

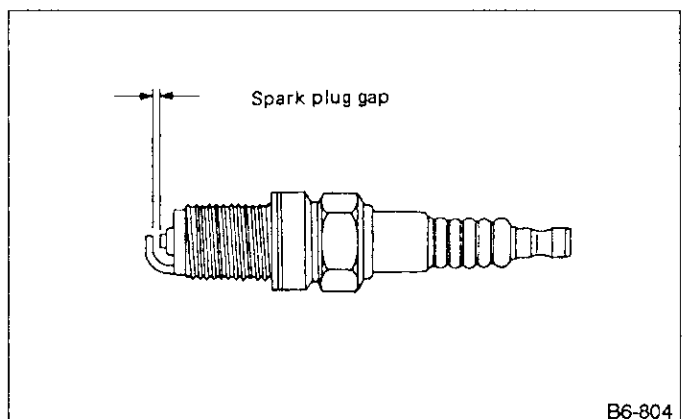


Fig. 122

All spark plugs installed on an engine, must be of the same heat range.

1600cc, 1800cc:

[Carburetor]

Recommended spark plug
NGK BKR6E
NIPPONDENSO K20PR-U
Spark plug gap
0.8 mm (0.031 in)

1800cc:

[SPFI]

Recommended spark plug
NGK BKR6E-11
NIPPONDENSO K20PR-U11
Spark plug gap
1.1 mm (0.043 in)

2000cc:

[NON-TURBO]

Recommended spark plug
NGK BKR6E-11
NIPPONDENSO K20PR-U11
Spark plug gap
1.1 mm (0.043 in)

[TURBO]

Recommended spark plug
NGK BKR6EVX
Spark plug gap
0.8 mm (0.031 in)

2200cc:

[without O₂ sensor]

Recommended spark plug
NGK BKR6E
NIPPONDENSO K20PR-U
Spark plug gap
0.8 mm (0.031 in)

[with O₂ sensor]

Recommended spark plug
NGK BKR6E-11
NIPPONDENSO K20PR-U11
Spark plug gap
1.1 mm (0.043 in)

B: REMOVAL AND INSTALLATION

1. EXCEPT TURBO MODEL

- 1) Remove spark plug cords by pulling boot, not cord itself.
- 2) Remove spark plugs.
- 3) When installing spark plugs on cylinder head, use spark plug wrench.

Tightening torque (Spark plug):

18 — 24 N·m (1.8 — 2.4 kg-m, 13 — 17 ft-lb)

The above torque should be only applied to new spark plugs without oil on their threads.

In case their threads are lubricated, the torque should be reduced by approximately 1/3 of the specified torque in order to avoid their over-stressing.

- 4) Connect spark plug cords.

2. TURBO MODEL

- 1) Remove ignition coil from cylinder head.
(Ref. to "5 Ignition Coil" [W5A2].)
- 2) Remove spark plug using spark plug wrench.

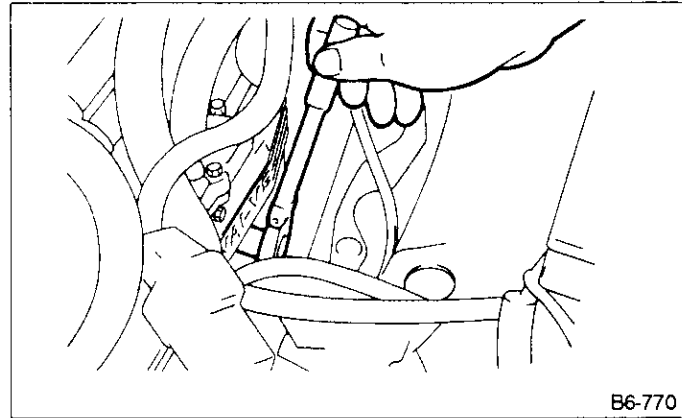


Fig. 123

- 3) When installing spark plug on cylinder head, use spark plug wrench.

Tightening torque (Spark plug):

20 — 29 N·m (2 — 3 kg-m, 14 — 22 ft-lb)

The above torque should be only applied to new spark plugs without oil their threads.

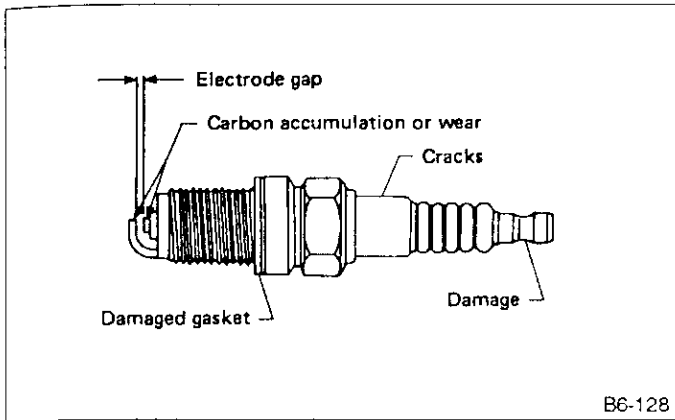
If their threads are lubricated, the torque should be reduced by approximately 1/3 of the specified torque in order to avoid over-stressing.

- 4) Install ignition coil.

Tightening torque (Ignition plug):

4.4 — 5.4 N·m (0.45 — 0.55 kg-m, 3.3 — 4.0 ft-lb)

C: INSPECTION



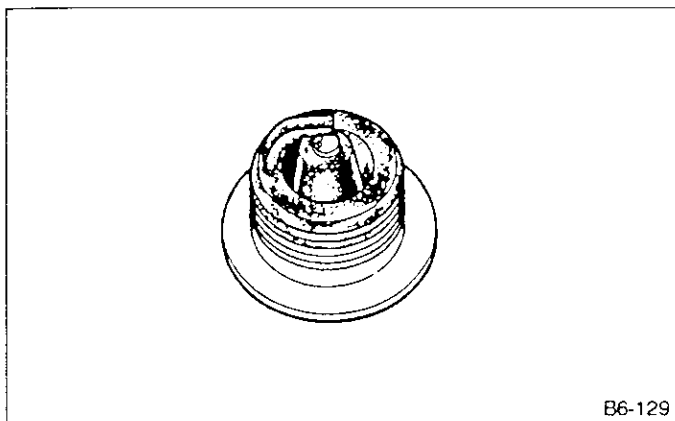
B6-128

Fig. 124

Check electrodes and inner and outer porcelain of plugs, noting the type of deposits and the degree of electrode erosion.

1) Normal

Brown to grayish-tan deposits and slight electrode wear indicate correct spark plug heat range.



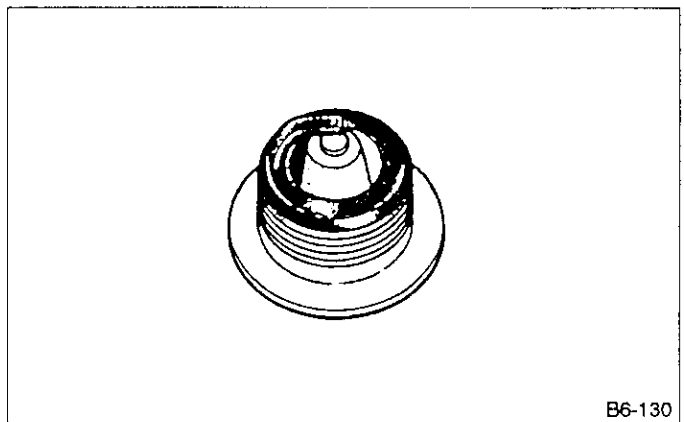
B6-129

Fig. 125

2) Carbon fouled

Dry fluffy carbon deposits on insulator and electrode are mostly caused by slow speed driving in city, weak ignition, too rich fuel mixture, dirty air cleaner, etc.

It is advisable to replace with plugs having hotter heat range.

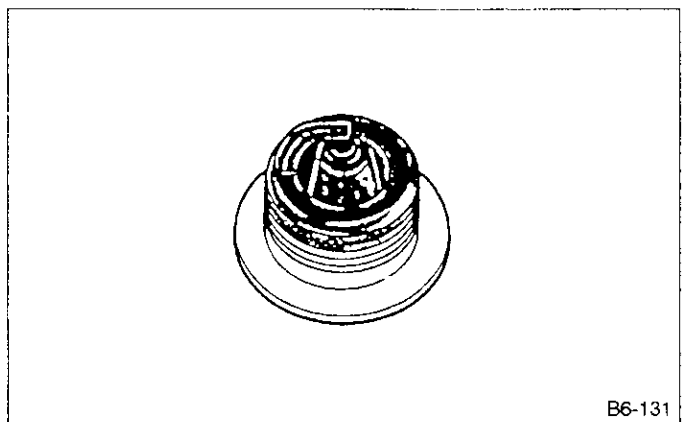


B6-130

Fig. 126

3) Oil fouled

Wet black deposits show excessive oil entrance into combustion chamber through worn rings and pistons or excessive clearance between valve guides and stems. If same condition remains after repair, use a hotter plug.

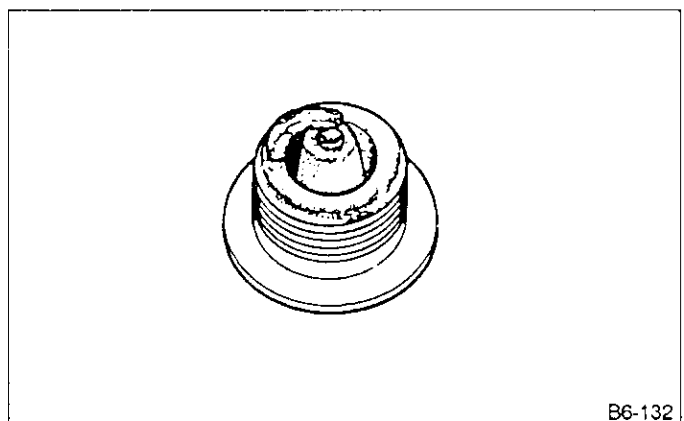


B6-131

Fig. 127

4) Overheating

White or light gray insulator with black or gray brown spots and bluish burnt electrodes indicate engine overheating. Moreover, the appearance results from incorrect ignition timing, loose spark plugs, wrong selection of fuel, hotter range plug, etc. It is advisable to replace with plugs having colder heat range.



B6-132

Fig. 128

D: CLEANING AND REGAPPING**1. EXCEPT TURBO MODEL**

Clean spark plugs in a sand blast type cleaner. Avoid excessive blasting. Clean and remove carbon or oxide deposits, but do not wear away porcelain. If deposits are too stubborn, discard plugs. After cleaning spark plugs, recondition firing surface of electrodes with file. Then correct the spark plug gap using a gap gauge.

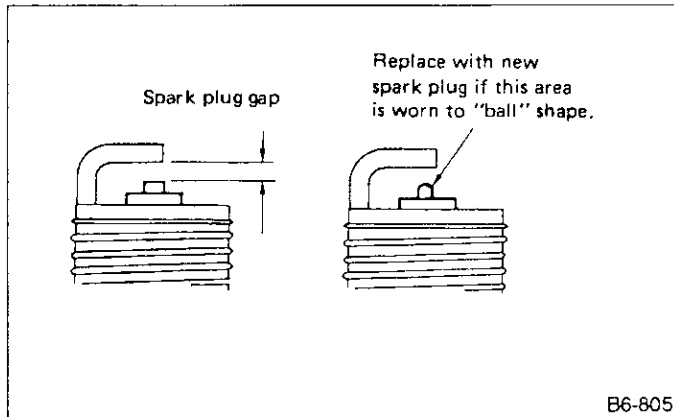


Fig. 129

B6-805

2. TURBO MODEL

Do not clean spark plug or adjust plug gap as this may damage platinum tip of electrode. However, if carbon accumulates excessively on electrodes due to "poor" sparks, use a sand blast type plug cleaner under the following conditions:

Plug cleaner usage condition:

Air pressure
588 kPa (6.0 kg/cm², 85 psi) or less
Time required
20 sec. or less

Never use wire brush when cleaning.

8. Spark Plug Cord

A: INSPECTION

Check for:

- 1) Damage to cords, deformation, burning or rust formation of terminals.
- 2) Resistance values of cords.

[MPFI]

	Resistance value (k Ω)	Length mm (in)
#1 cord	5.29 — 12.34	575 (22.64)
#2 cord	5.24 — 12.23	570 (22.44)
#3 cord	5.29 — 12.34	575 (22.64)
#4 cord	5.96 — 13.91	645 (25.39)

[SPFI and Carburetor]

	Resistance value (k Ω)	Length mm (in)
Distributor cord	6.1 — 11.4	550 (21.65)
#1 cord	6.5 — 12.0	640 (25.20)
#2 cord	11.5 — 21.4	1,090 (42.91)
#3 cord	5.7 — 10.6	570 (22.44)
#4 cord	11.6 — 21.6	1,100 (43.31)

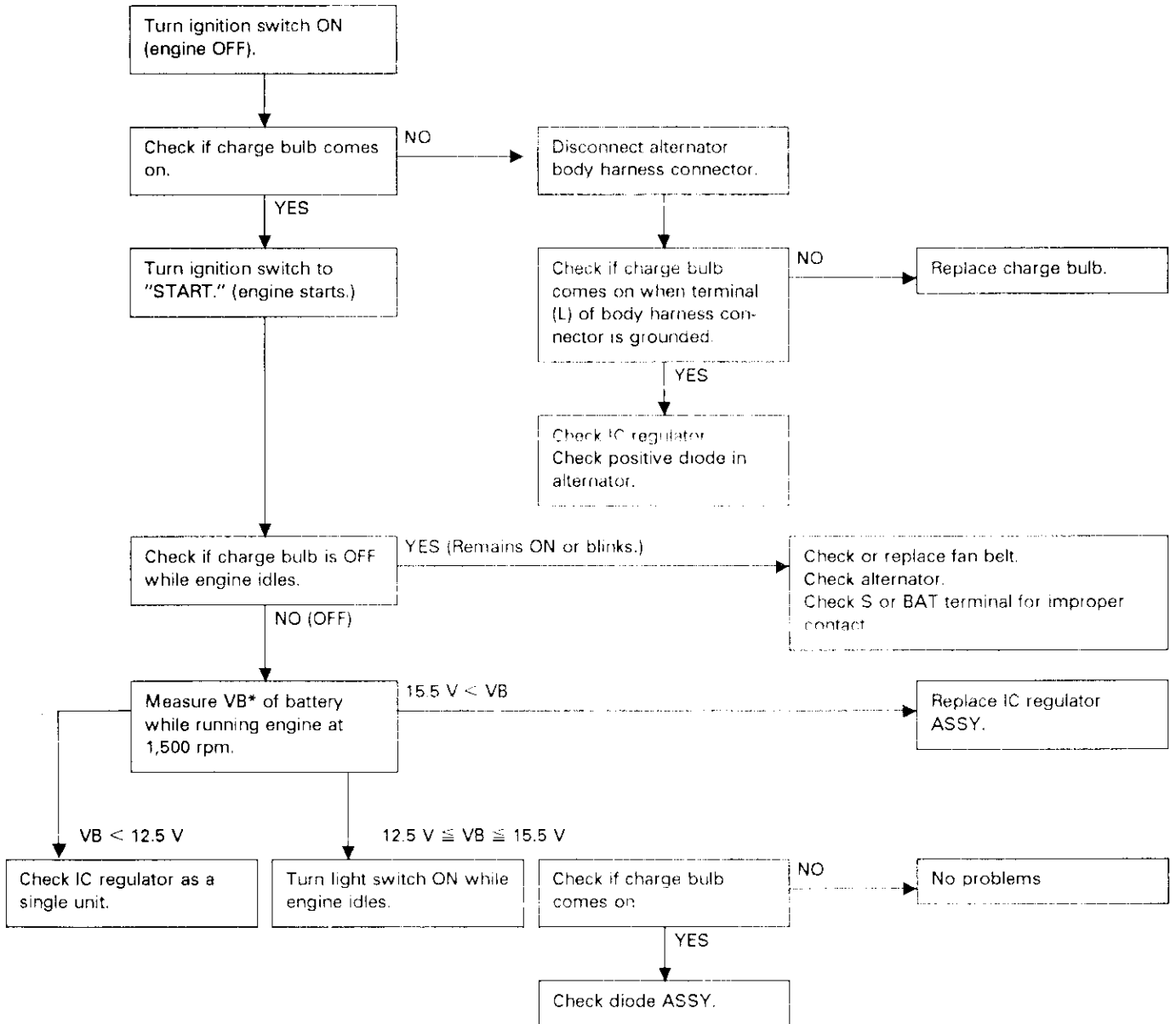
T TROUBLESHOOTING

1. Starter

If battery and wiring harness are satisfactory, inspect starter with the following table.

Trouble		Probable cause
Starter does not start.	Magnet switch does not operate (no clicks are heard).	Magnet switch poor contact or discontinuity of pull-in coil circuit Improper sliding of magnet switch plunger
	Magnet switch operates (clicks are issued).	Poor contact of magnet switch's main contact point Layer short of armature Contaminants on armature commutator High armature mica Insufficient carbon brush length Insufficient brush spring pressure
Starter starts but does not crank engine.	Failure of pinion gear to engage ring gear	Worn pinion teeth Improper sliding of overrunning clutch Improper adjustment of stud bolt (manufactured by NIPPONDENSO.)
	Clutch slippage	Faulty clutch
Starter starts but engine cranks too slowly.		Poor contact of magnet switch's main contact point Layer short of armature Discontinuity, burning or wear of armature commutator Insufficient brush length Insufficient brush spring pressure Abnormal brush wear
Starter overruns.		Magnet switch coil is a layer short.

2. Alternator



*: Terminal voltage

SUBARU®

1992

**SERVICE
MANUAL**



	Page
M MECHANISM AND FUNCTION	2
1. Low Fuel Warning Light Delay Amplifier	2
S SPECIFICATIONS AND SERVICE DATA	3
W SERVICE PROCEDURE	5
1. Power Supply Routing	5
2. Charging	11
3. Starting	12
4. Engine Electrical	15
5. Cooling Fan	19
6. Lighting	20
7. Room Light and Door Switch	26
8. Stop Light	28
9. Turn Signal and Hazard Warning Light	30
10. Trunk Room Light	32
11. Back-Up Light	33
12. Rear Fog Light	34
13. Automatic Transmission Control (4AT)	35
14. 4WD-MT	36
15. Front Wiper and Washer	38
16. Rear Wiper and Washer	42
17. Headlight Washer	47
18. Rear Window Defogger	48
19. Parking Brake Switch and Brake Fluid Level Warning	51
20. Fuel Gauge	52
21. Combination Meter	54
22. Oil Pressure Indicator Light and Temperature Gauge	60
23. Power Window	61
24. Door Lock	64
25. Horn and Cigarette Lighter	65
26. Sunroof, Spot Light and Vanity Mirror	68
27. Radio and Antenna	70
28. Mode Selector and Blower Motor	72
29. Remote Control Rearview Mirror	72
30. Pneumatic Suspension (Air Suspension)	75
31. Antilock Brake System	76
32. Cruise Control	77
33. Headlight Beam Leveler	86
T TROUBLESHOOTING (For Cruise Control)	87
1. Self Diagnosis	87
2. I/O Signal of Cruise Control Unit	90
3. Basic Troubleshooting Procedure	91
4. Trouble Chart A	94
5. Trouble Chart B	98
6. Trouble Chart C	113

M MECHANISM AND FUNCTION

1. Low Fuel Warning Light Delay Amplifier

To prevent temporary illumination of the low fuel warning light when the vehicle is making a right turn or when starting off, a delay amplifier is installed inside the combination meter of 4WD models.

1. OPERATION

1) When the vehicle makes a right turn, fuel moves into the left-chamber of the fuel tank.

2) After completing the right turn, fuel is moved back to the fuel tank right-chamber by a jet pump.

3) The pumping capacity of the jet pump is approximately 1 ℓ (1.1 US qt, 0.9 Imp qt) per minute.

4) The delay amplifier delay time is set to approximately 3 minutes.

5) During this 3-minute period, approximately 3 ℓ (3.2 US qt, 2.6 Imp qt) of fuel is pumped back from the left-chamber to the right-chamber. If approximately 6 ℓ (6.3 US qt, 5.3 Imp qt) of fuel is left in the right-chamber, temporary illumination of the low fuel warning light can be prevented.

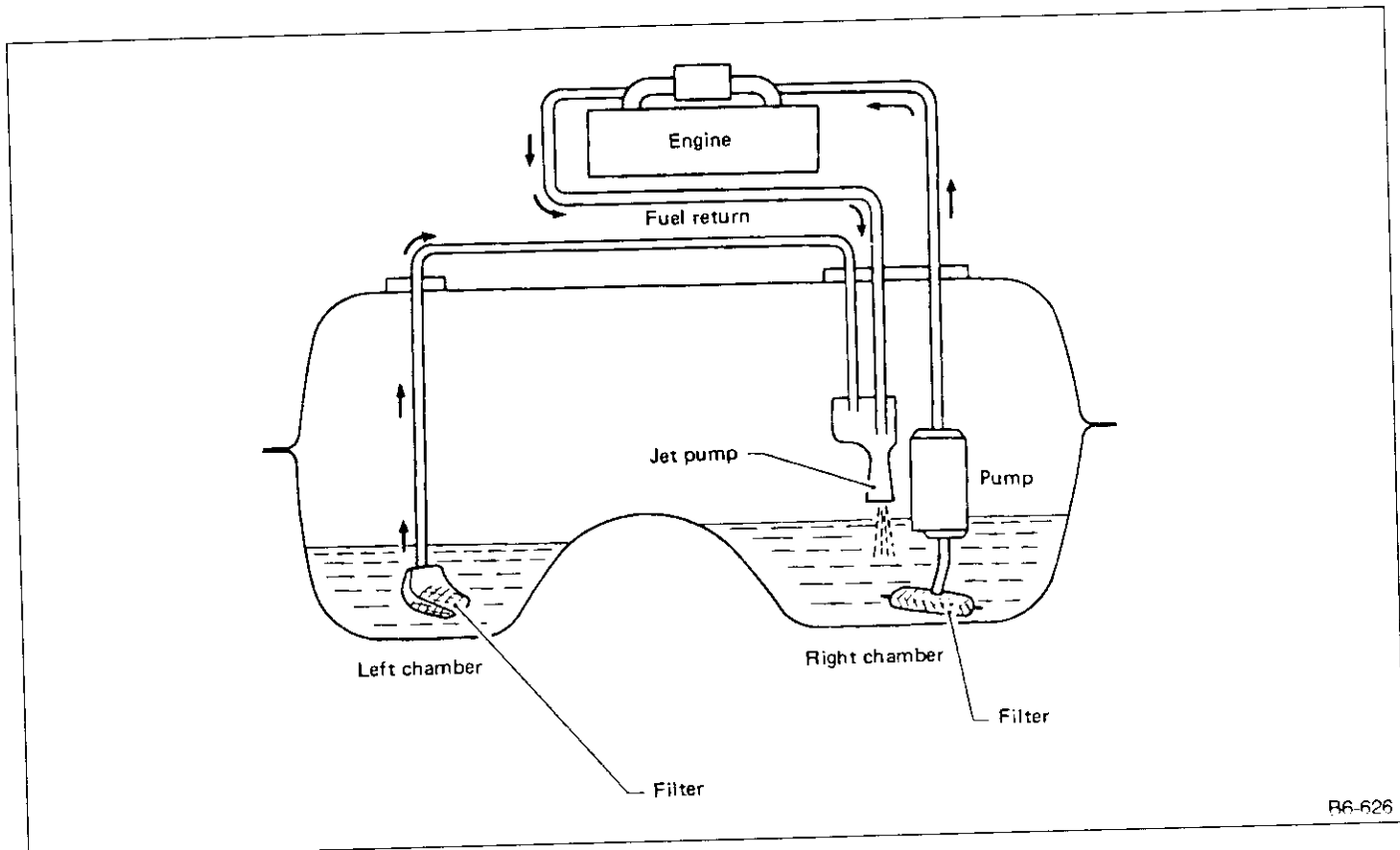


Fig. 1

RG-626

S SPECIFICATIONS AND SERVICE DATA

Battery	Type		EUROPE	OTHERS
			MT: 55D23L (MF) AT: 75D23L (MF)	MT: 34B19L (MF) AT: 46B24L (MF)
Capacity	Capacity	Reverse capacity	MT: 99 minutes AT: 111 minutes	MT: 49 minutes AT: 71 minutes
		Cold cranking ampere	MT: 356 amperes AT: 490 amperes	MT: 272 amperes AT: 325 amperes
Fuses			10 A: 7 15 A: 11 20 A: 7	
Combi- nation meter	Speedometer		Eddy current type, Electric impulse type.	
	Temperature gauge		Thermistor-cross coil type	
	Fuel gauge		Resistance cross coil type	
	Tachometer		Electric impulse type	
	Turn signal indicator light		12 V — 1.4 W (× 2)	
	Low fuel indicator light		12 V — 3 W	
	Charge indicator light		12 V — 1.4 W	
	Oil pressure indicator light		12 V — 1.4 W	
	ANTILOCK BRAKE warning light		12 V — 1.4 W	
	AT oil temp. warning light		12 V — 1.4 W	
	CHECK ENGINE warning light		12 V — 1.4 W	
	High beam indicator light		12 V — 1.12 W	
	Door open warning light		12 V — 1.12 W (× 4)	
	Rear gate open warning light		12 V — 1.12 W	
	Seat belt warning light		12 V — 1.12 W	
	Brake fluid, parking brake warning light		12 V — 1.4 W	
	FWD warning light		12 V — 1.12 W	
	4WD indicator light		12 V — 1.12 W	
	4WD Lo indicator light		12 V — 1.12 W	
	Meter illumination light		12 V — 3W (× 4) 12 V — 3.4 W (× 2)	
AT indi- cator	Power indicator light		12 V — 1.12 W	
	Manual indicator light		12 V — 1.12 W	
	P•R•N•D•3•2•1 (4AT) P•R•N•D•2•1 (3AT)		12 V — 1.12 W	

Headlight		12 V — 60/55 W (Halogen)
Front turn signal light		12 V — 21 W
Rear combination light	Tail/Stop light	12 V — 5/21 W
	Turn signal light	12 V — 21 W
	Back-up light	12 V — 21 W
	Rear fog light	12 V — 21 W
Side turn signal light		12 V — 5 W
Room light		12 V — 8 W
Spot light		12 V — 8 W (× 2)
License plate light		12 V — 10 W (Sedan) 12 V — 5 W (Wagon)
Luggage room light		12 V — 5 W
Glove box light		12 V — 3.4 W
Ash tray illumination light		12 V — 1.4 W
Selector lever illumination light		12 V — 1.7 W
Clearance light		12 V — 10 W
Front wiper	Input	12 V — 54 W or less
Front washer	Pump type	Centrifugal
	Input	12 V — 36 W or less
Rear window wiper	Input	12 V — 42 W or less
Rear window washer	Pump type	Centrifugal
	Input	12 V — 36 W or less
Radio	Type	AM, AM/FM stereo, AM/FM stereo (ETR), AM/FM/LW stereo
	Speaker position	Upper panel of instrument panel (× 1) for AM Front (× 2) Rear (× 2)
Horn		12 V — 420 ± 20 Hz 12 V — 350 ± 20 Hz
Cigarette lighter	Input	12 V — 120 W
	Illumination light	12 V — 1.4 W
Rear window defogger	Input	12 V — 160 ± 16 W
	Indicator light	12 V — 50 mA
Headlight washer	Pump type	Centrifugal
	Input	12 V — 240 W or less

W SERVICE PROCEDURE

- a. Before disassembling or reassembling parts, always disconnect battery ground cable. When repairing radio, control units, etc. which are provided with memory functions, record memory contents before disconnecting battery ground cable. Otherwise, these contents are canceled upon disconnection.
- b. Reassemble parts in reverse order of disassembly procedure unless otherwise indicated.
- c. Adjust parts to specifications contained in this manual if so designated.
- d. Connect connectors and hoses securely during reassembly.
- e. After reassembly, ensure functional parts operate smoothly.

1. Power Supply Routing

A: DESCRIPTION

1. IGNITION SWITCH

Ignition switch is installed on steering column and steering lock mechanism is provided.

Key plate can be pulled out of ignition switch only in "LOCK" position.

On AT models equipped with key interlock, ignition switch can be turned from ACC to LOCK and key plate can be removed from ignition switch only when selector lever is in "P".

2. MAIN FUSE BOX (M/B)

Main fuse box (M/B), which consists of relays, fuses and fusible links, is located at rear of battery. It is connected to battery positive terminal. It has a connection which is connected to front wiring harness.

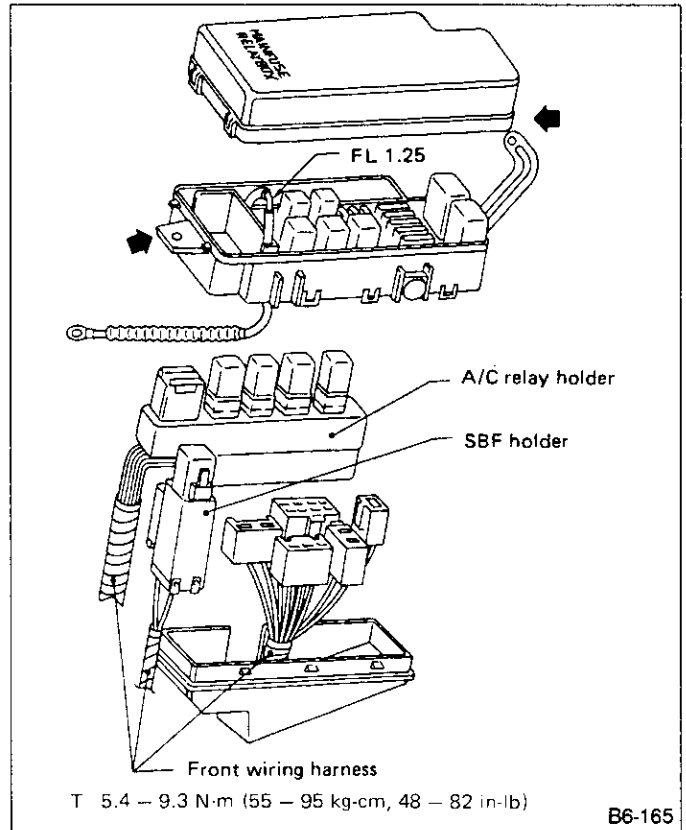


Fig. 2

1) FUSIBLE LINK (FL 1.25)

If current increases beyond specified amperage, fusible metal melts and the circuit is broken, thus protecting cable and electrical equipment from burning.

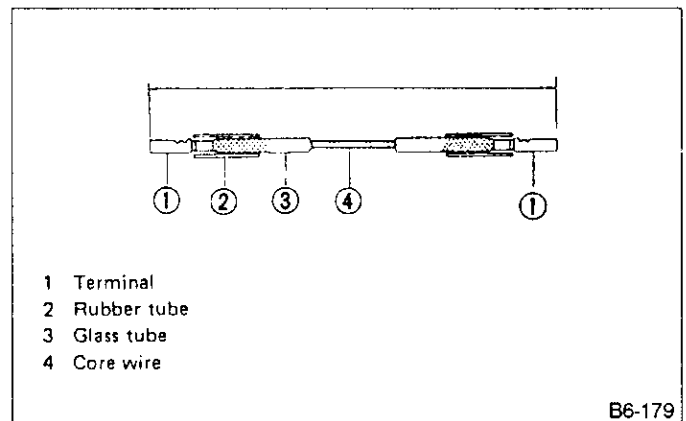


Fig. 3

- a. When replacing fusible link, be sure to use one with the specified rating.
- b. Blown fusible link is caused by short circuit in the source of electricity circuit or large amperage circuit, so careful check of cause and/or repair is necessary.

No.	Item	Nominal gauge size of conductor
		1.25 mm ² (0.00194 sq in)
1	Voltage drop	50 mV
		Voltage drop across lug terminals should be less than the above value when a 10-ampere current flows through fusible link at room temperature.
2	Melting characteristics	Fusible link should melt within 15 seconds at a current flow of 190 amperes

2) FUSE

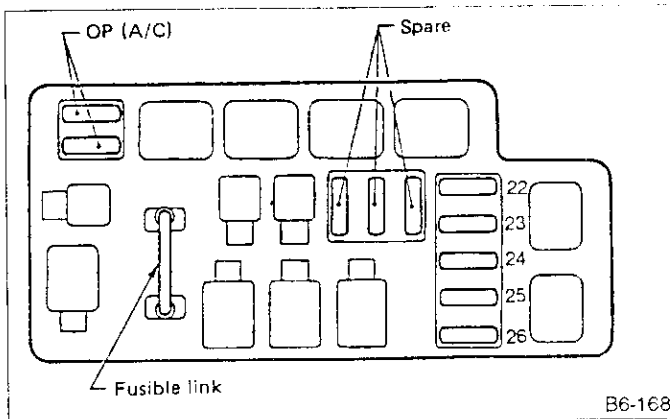


Fig. 4

No.	Rating	Component
No. 22	15A	Hazard warning light
No. 23	20A	Lighting switch
No. 24	15A	Headlight (LH)
No. 25	10A	Clock Room light
No. 26	15A	Headlight (RH)
(O P)	20A	A/C (Sub fan)
(O P)	10A	A/C
SPARE	20A	—
SPARE	15A	—
SPARE	10A	—

3. FUSE AND JOINT BOX (F/B)

Fuse and joint box (F/B) is located under instrument panel on driver's side. It consists of small-capacity relays, fuses (including spare fuses) and F/B light (which turns ON or OFF when door is opened or closed). It also has three connections which are connected to front wiring harness, bulkhead wiring harness and instrument wiring harness.

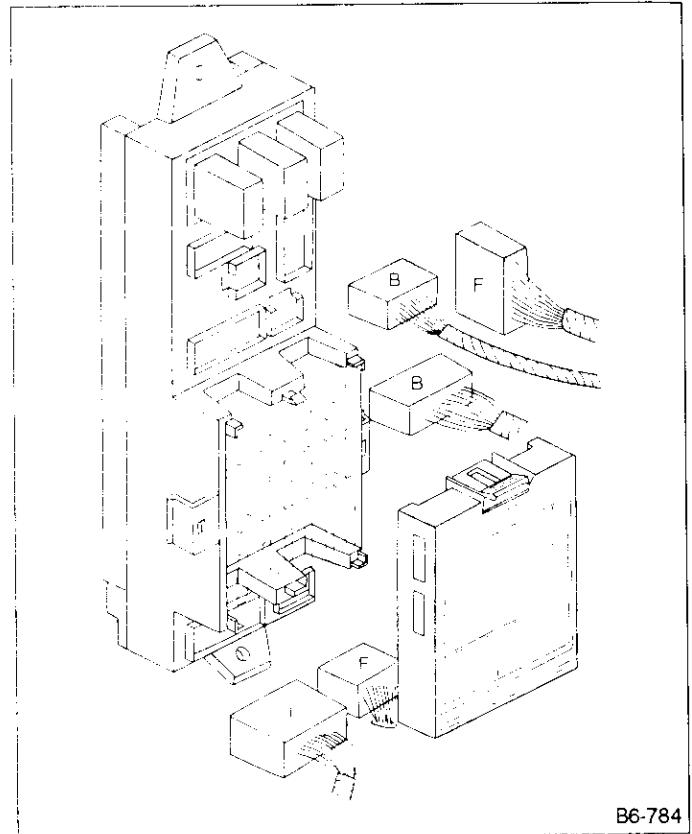


Fig. 5

- F: Front wiring harness
- B: Bulkhead wiring harness
- I: Instrument panel wiring harness

Tightening torque:

5.4 — 9.3 N·m
(55 — 95 kg-cm, 48 — 82 in-lb)

1) FUSE

The connection between each fuse and main electrical units/devices is as shown in the following illustration. (Also refer to the wiring diagram.)

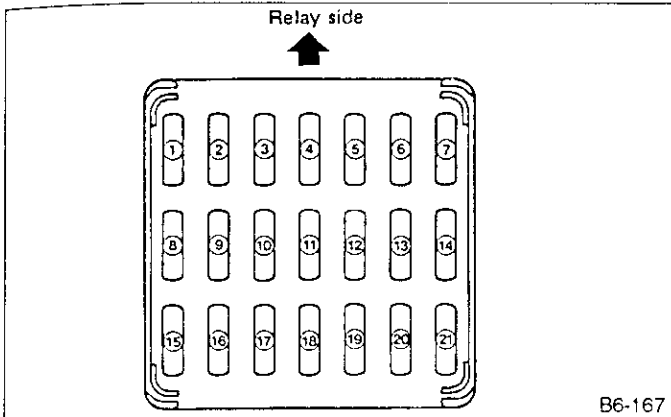


Fig. 6

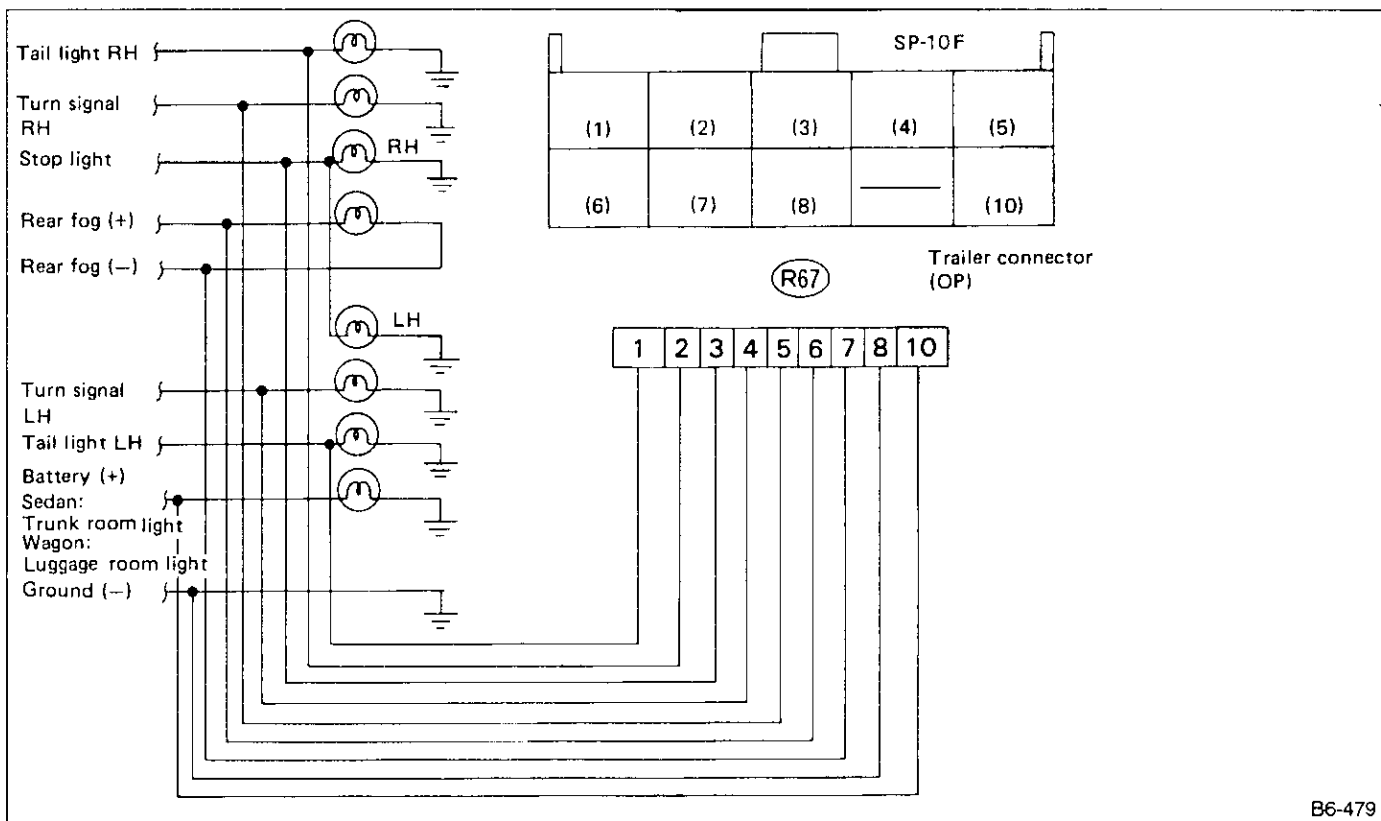
No. 1	15 A	Back-up light, Turn signal light
No. 2	20 A	Windshield wiper and washer
No. 3	15 A	Cigarette lighter, Remote control rearview mirrors
No. 4	10 A	Tail light LH
No. 5	10 A	Tail light RH
No. 6	Empty	
No. 7	20 A	Rear window defogger
No. 8	10 A	Cruise control, ABS system
No. 9	10 A	Illumination
No. 10	10 A	Height control
No. 11	20 A	Power door lock
No. 12	20 A	Stop light, Horn
No. 13	20 A	Main fan
No. 14	10 A	MPFI, AT unit
No. 15	10 A	Meter
No. 16	15 A	Ignition system
No. 17	15 A	Radio
No. 18	15 A	
No. 19	20 A	ABS solenoid
No. 20	15 A	Heater fan
No. 21	15 A	Heater fan

- a. When replacing fuse, be sure to use fuse of specified rating.
- b. If fuse is blown, be sure to eliminate cause before installing new fuse in position.
- c. Poor contact of any fuse holder will often lead to voltage drop or heating in the circuit or fuse holder and could result in blown fuse, so be careful with holder contacting and clean metal parts if necessary.

4. TOWING POWER CONNECTOR

When additional power is required to activate trailer's lights (for camping cars, etc.), do not exceed rated power capacity indicated in table below.

Terminal No. (R67)	Additional circuit	Additional capacity available
(1)	Tail light LH	10 (W)
(2)	Tail light RH	10 (W)
(3)	Stop light LH/RH	42 (W)
(4)	Turn signal light LH	21 (W)
(5)	Turn signal light RH	21 (W)
(6)	Rear fog light (+)	21 (W)
(7)	Rear fog light (-)	
(8)	Ground	146 (W)
(10)	Battery + B	21 (W)



B6-479

Fig. 7

For details, refer to applicable wiring diagrams.

B: REMOVAL AND INSTALLATION

1. BATTERY

- 1) Disconnect the positive (+) terminal after disconnecting the negative (-) terminal of battery.
- 2) Remove flange nuts from battery rods and take off battery holder.
- 3) Remove battery.
- 4) Installation should follow the removal procedure in the reverse order.

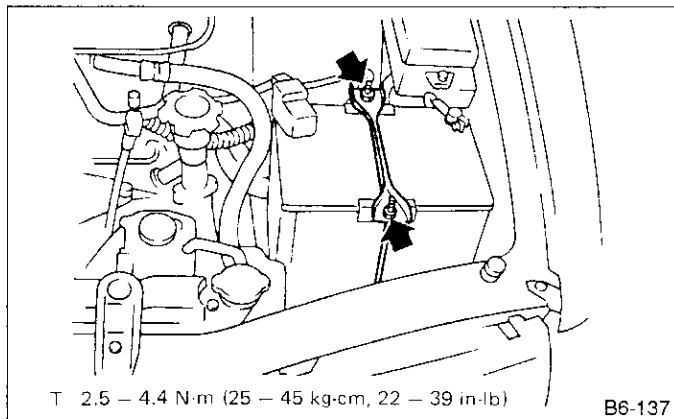


Fig. 8

- a. Clean battery cable terminals and apply grease to retard the formation of corrosion.
- b. Connect the positive (+) terminal of battery and then the negative (-) terminal of the battery.

2. IGNITION KEY CYLINDER

- 1) Remove lower column cover.

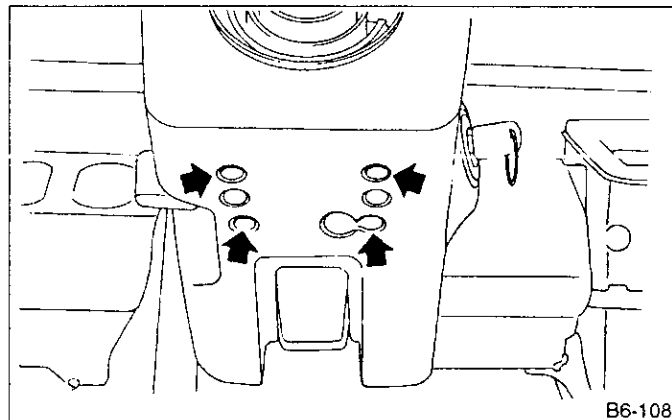


Fig. 9

- 2) Turn ignition switch to ACC, and press dowel in dowel pin hole using a 2 mm (0.08 in) dia. rod to remove key cylinder.

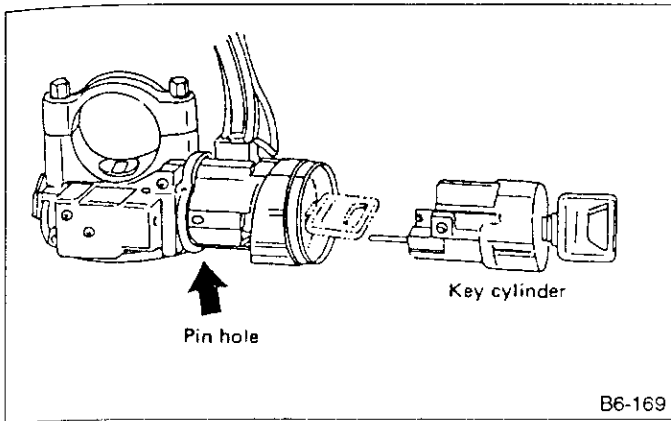


Fig. 10

3. IGNITION KEY SWITCH

- 1) Remove instrument panel lower cover.
 - 2) Remove screws, and separate upper column cover and lower column cover.
 - 3) Disconnect connector from body harness.
 - 4) Cut off the bolt which connects upper and lower portions of ignition key switch, and remove the switch.
- Remove steering column before cutting off the bolt. The upper and lower portions of ignition key switch can be loosened by tapping the cut-off surface of the bolt using a punch and hammer.

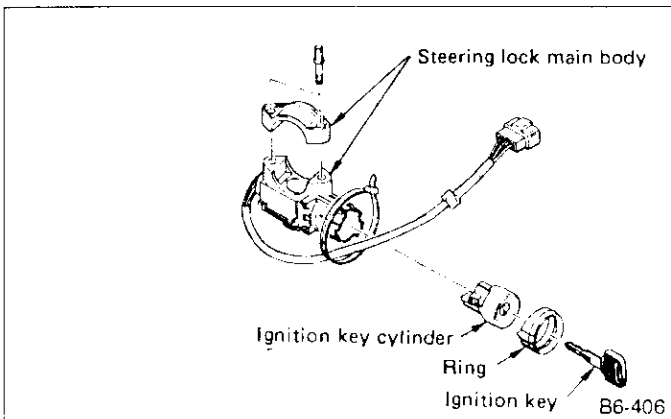


Fig. 11

Tighten the connecting bolt until its head twists off.

C: INSPECTION

1. BATTERY

- 1) External parts
Check for the existence of dirt or cracks on the battery case, top cover, vent plugs, and terminal posts. If necessary, clean with water and wipe with a dry cloth. Apply a thin coat of grease on the terminal posts to prevent corrosion.
- 2) Electrolyte level
Check the electrolyte level in each cell. If the level is below MIN LEVEL, bring the level to MAX LEVEL by

pouring distilled water into the battery cell. Do not fill beyond MAX LEVEL.

- a. Electrolyte has toxicity; be careful handling the fluid.
- b. Avoid contact with skin, eyes or clothing. Especially at contact with eyes, blush with water for 15 minutes and get prompt medical attention.
- c. Batteries produce explosive gasses. Keep sparks, flame, cigarettes away.
- d. Ventilate when charging or using in enclosed space.
- e. For safety, in case an explosion does occur, wear eye protection or shield your eyes when working near any battery. Never lean over a battery.
- f. Do not let battery fluid contact eyes, skin, fabrics, or paint-work because battery fluid is corrosive acid.
- g. To lessen the risk of sparks, remove rings, metal watch-bands, and other metal jewelry. Never allow metal tools to contact the positive battery terminal and anything connected to it WHILE you are at the same time in contact with any other metallic portion of the vehicle because a short circuit will be caused.

3) Specific gravity of electrolyte
Measure specific gravity of electrolyte using a hydrometer and a thermometer. Specific gravity varies with temperature of electrolyte so that it must be corrected at 20°C (68°F) using the following Equation:

$$S_{20} = St + 0.0007 \times (t - 20)$$

S_{20} : Specific gravity corrected at electrolyte temperature of 20°C

St : Measured specific gravity

t : Measured temperature (°C)

Determine whether or not battery must be charged, according to corrected specific gravity.
Standard specific gravity: 1.220 — 1.290 [at 20°C (68°F)]

Measuring the specific gravity of the electrolyte in the battery will disclose the state of charge of the battery. The relation between the specific gravity and the stage of charge is as shown in figure.

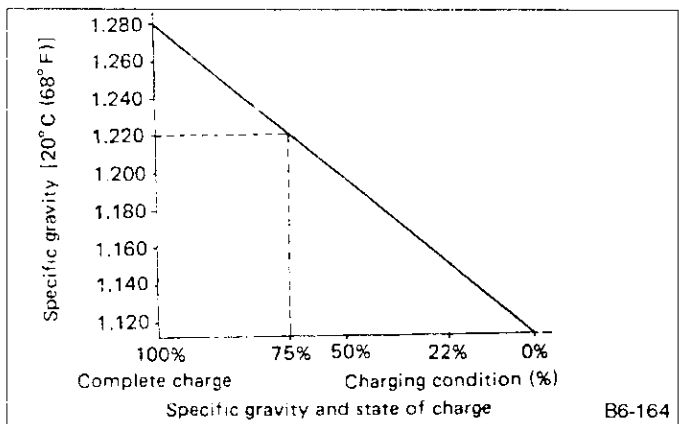


Fig. 12

2. IGNITION SWITCH

- 1) Remove instrument panel lower cover.
- 2) Remove lower column cover.
- 3) Disconnect connector from body harness.

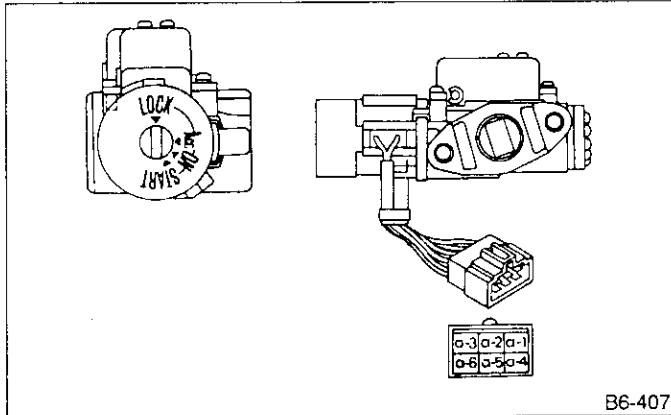


Fig. 13

Turn ignition switch to each position and check continuity between terminals, as indicated in the following table.

IGNITION

Terminal (Wire color)	a-1 (BW)	a-2 (BL)	a-5 (B)	a-4 (BY)
Position				
LOCK				
ACC	○	○		
ON	○	○	○	
START	○		○	○

D: CHARGING

- a. Do not bring an open flame close to the battery at this time.
- b. Prior to charging, corroded terminals should be cleaned with a brush and common baking soda solution.
- c. Be careful since battery electrolyte overflows while charging the battery.
- d. Observe instructions when handling battery charger.
- e. Before charging the battery on vehicle, disconnect battery ground terminal. Failure to follow this rule may damage alternator's diodes or other electrical units.

1. NORMAL CHARGING

Charge the battery at current value specified by manufacturer or at approximately 1/10 of battery's ampere-hour rating.

2. QUICK CHARGING

Quick charging is a method in which the battery is charged in a short period of time with a relatively large current by using a quick charger.

Since a large current flow raises electrolyte temperature, the battery is subject to damage if the large current is used for prolonged time. For this reason, the quick charging must be carried out within a current range that will not increase the electrolyte temperature above 40°C (104°F).

It should be also remembered that the quick charging is a temporary means to bring battery voltage up to a fair value and, as a rule, a battery should be charged slowly with a low current.

- a. Observe the items in NOTE in 1) Normal charging.
- b. Never use more than 10 amperes when charging the battery because that will shorten battery life.

3. JUDGMENT OF BATTERY IN CHARGED CONDITION

- 1) Specific gravity of electrolyte is held at a specific value in a range from 1.250 to 1.290 for more than one hour.
- 2) Voltage per battery cell is held at a specific value in a range from 2.5 to 2.8 volts for more than one hour.

2. Charging

A: SCHEMATIC

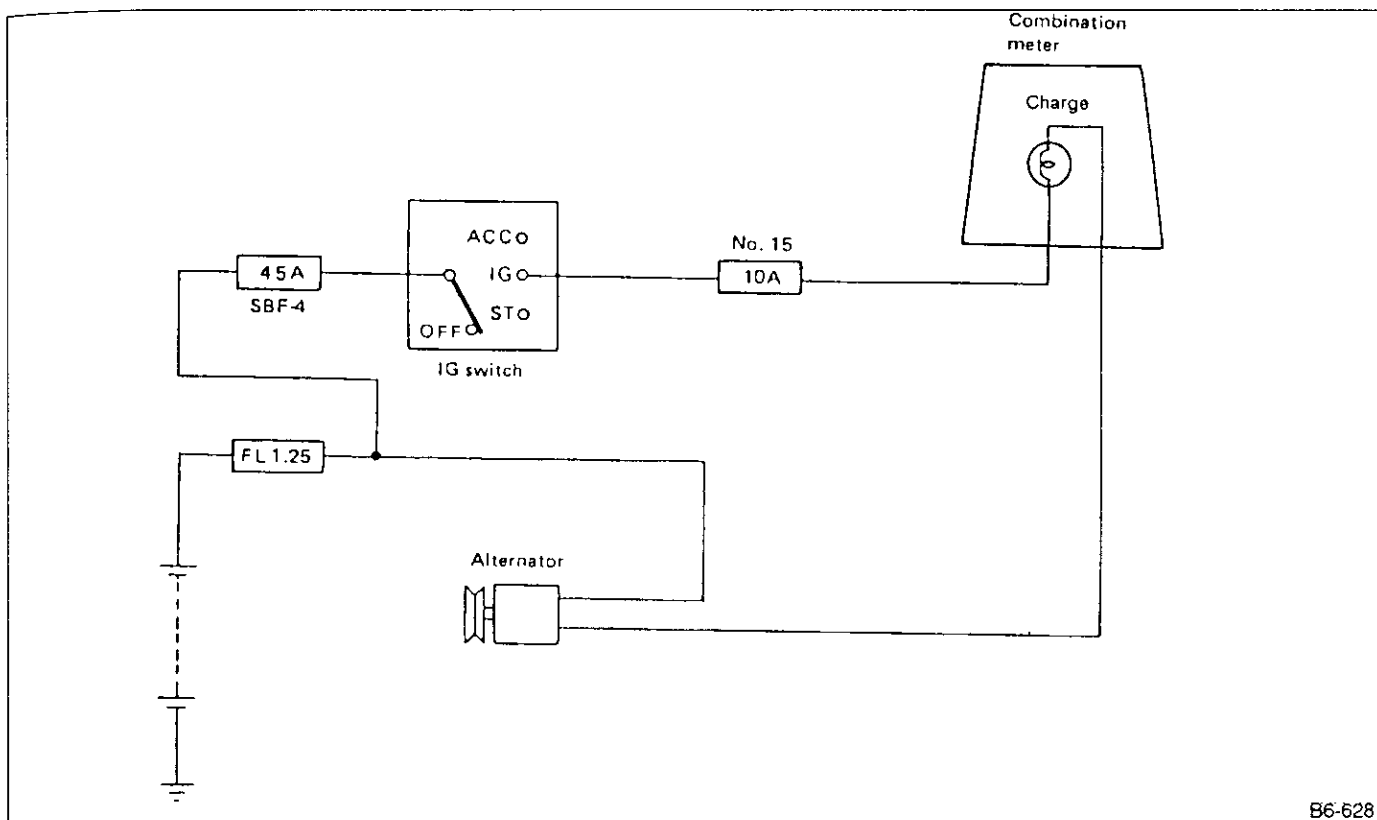


Fig. 14

96-628

3. Starting

A: SCHEMATIC

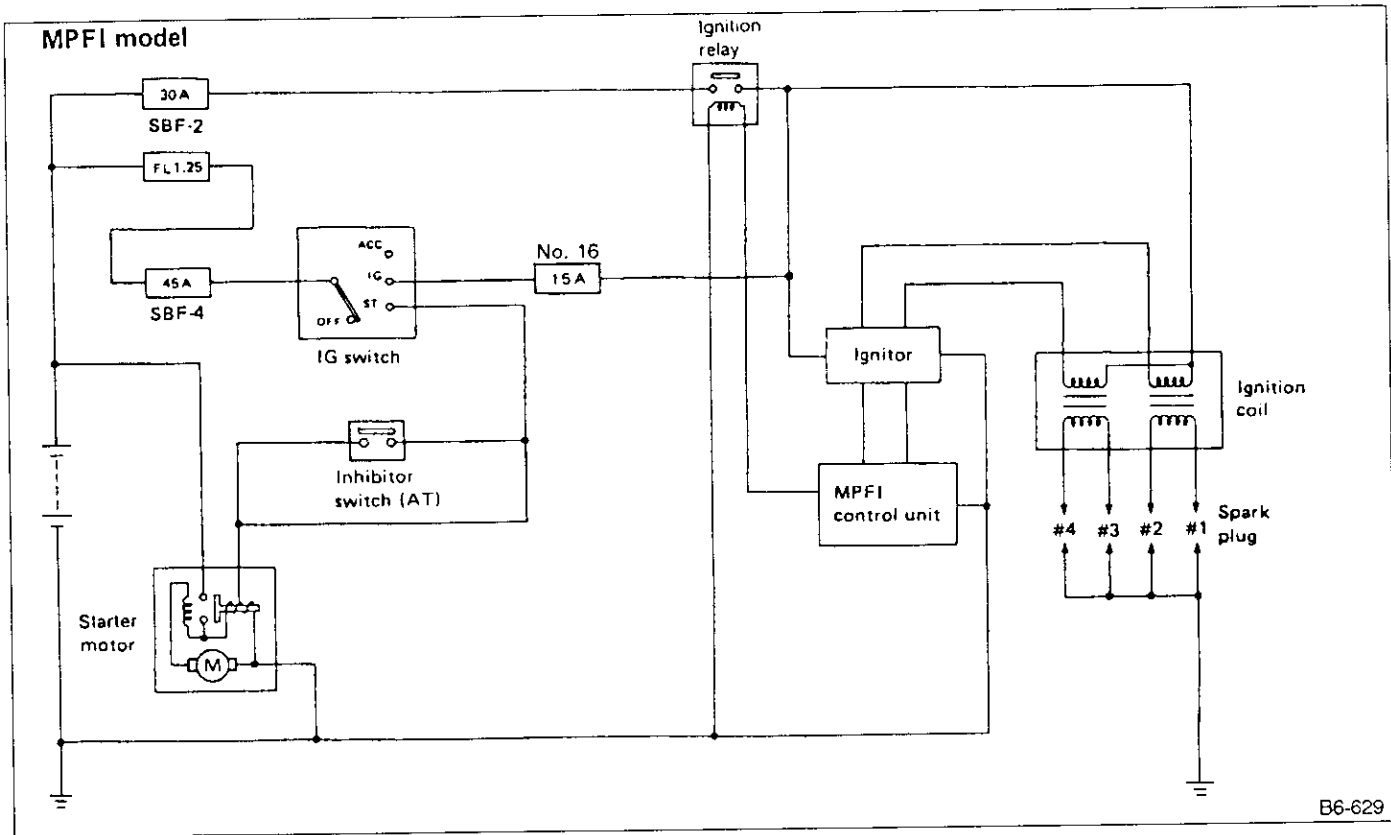
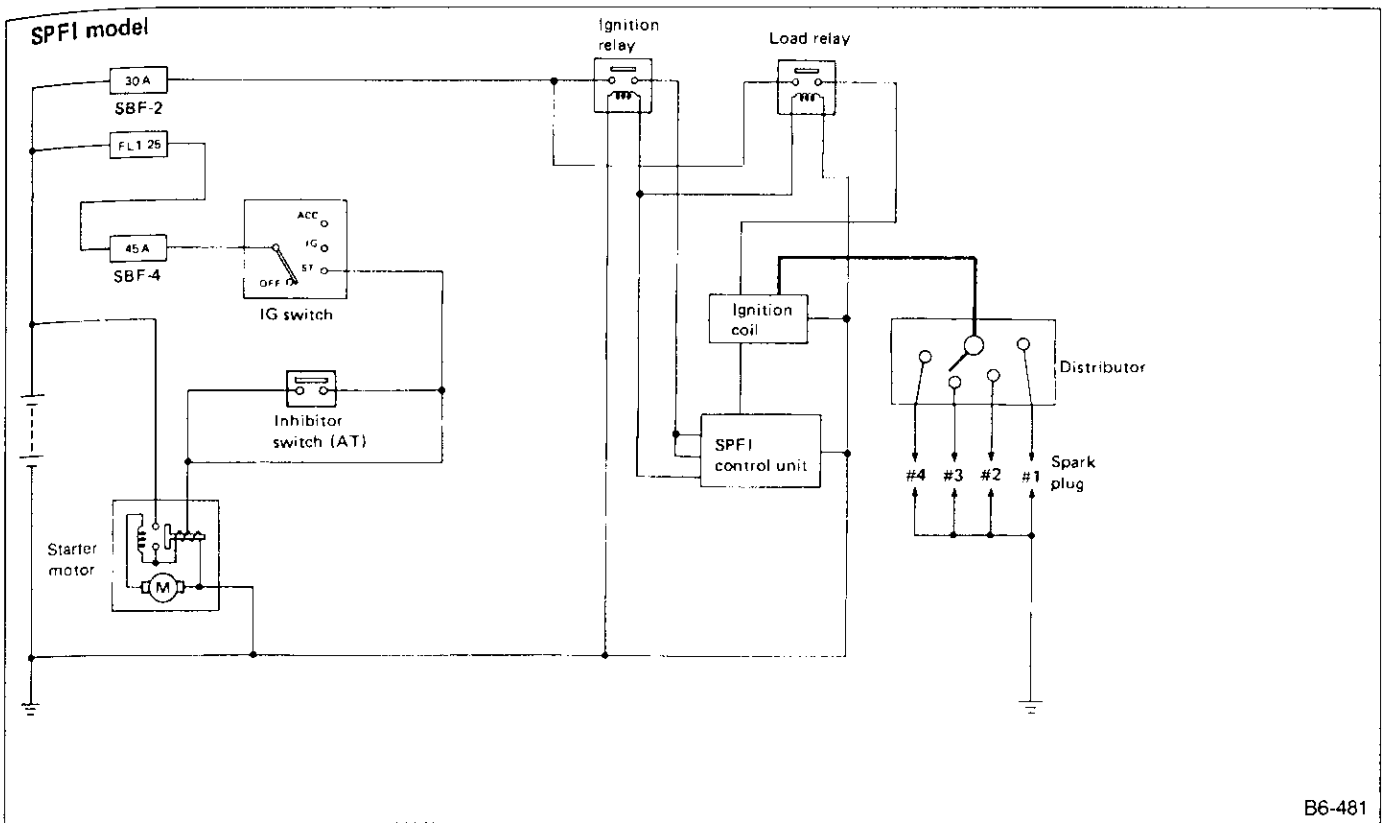
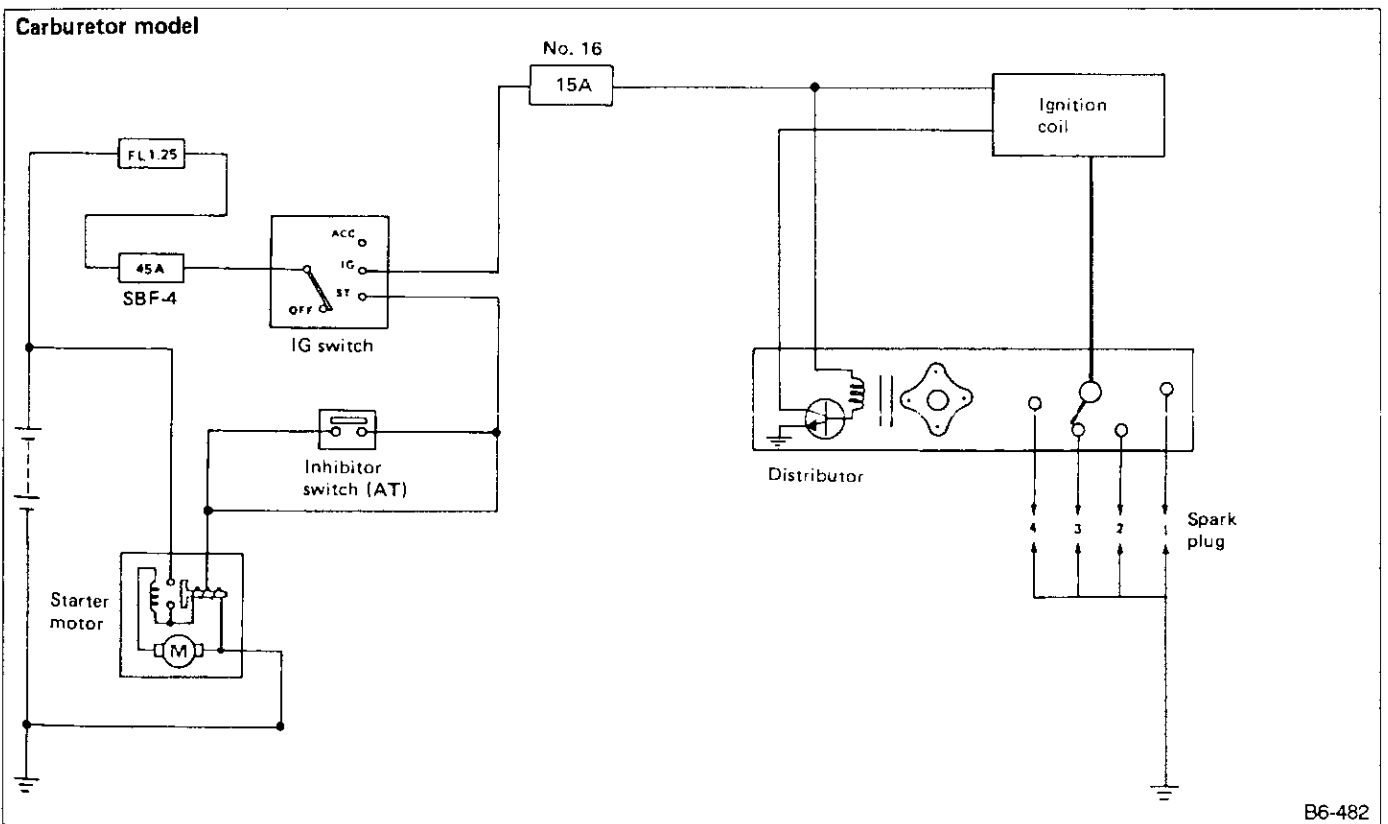


Fig. 15



B6-481

Fig. 16



B6-482

Fig. 17

B: INSPECTION

INHIBITOR SWITCH

<Ref. to [3-2]>.

4. Engine Electrical

A: SCHEMATIC

1. MPFI model (NA)

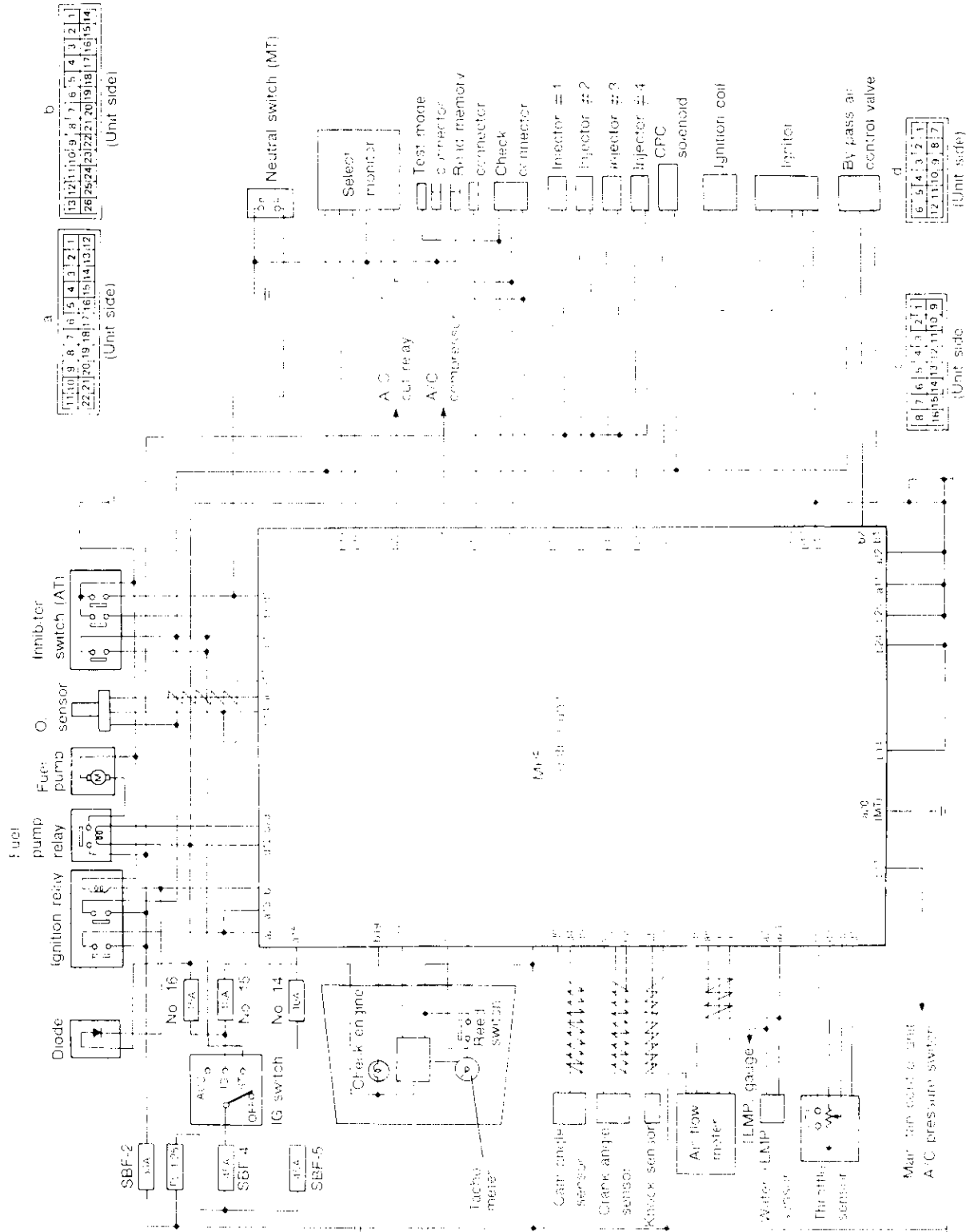


Fig. 18

B6-785

2. SPFI model

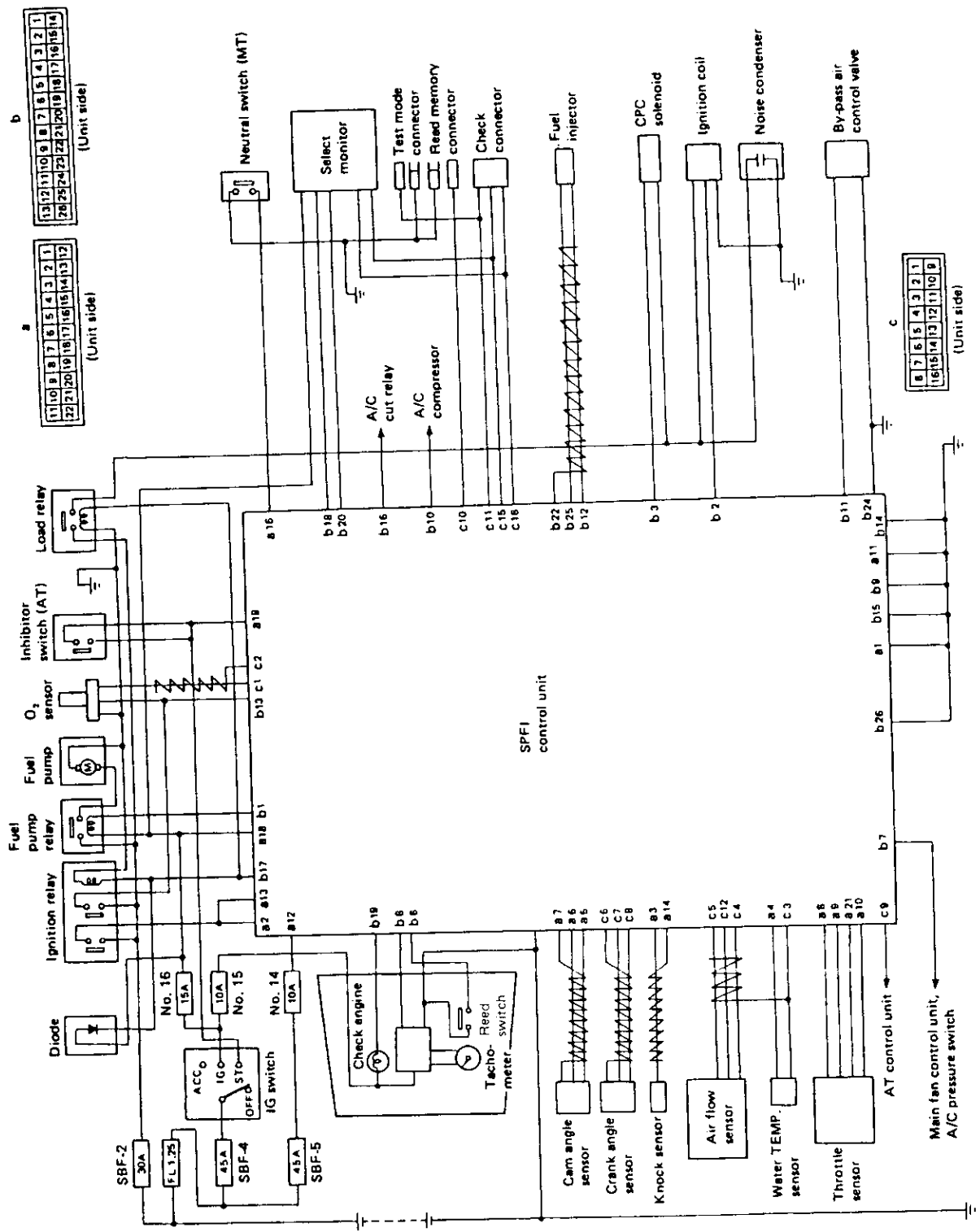
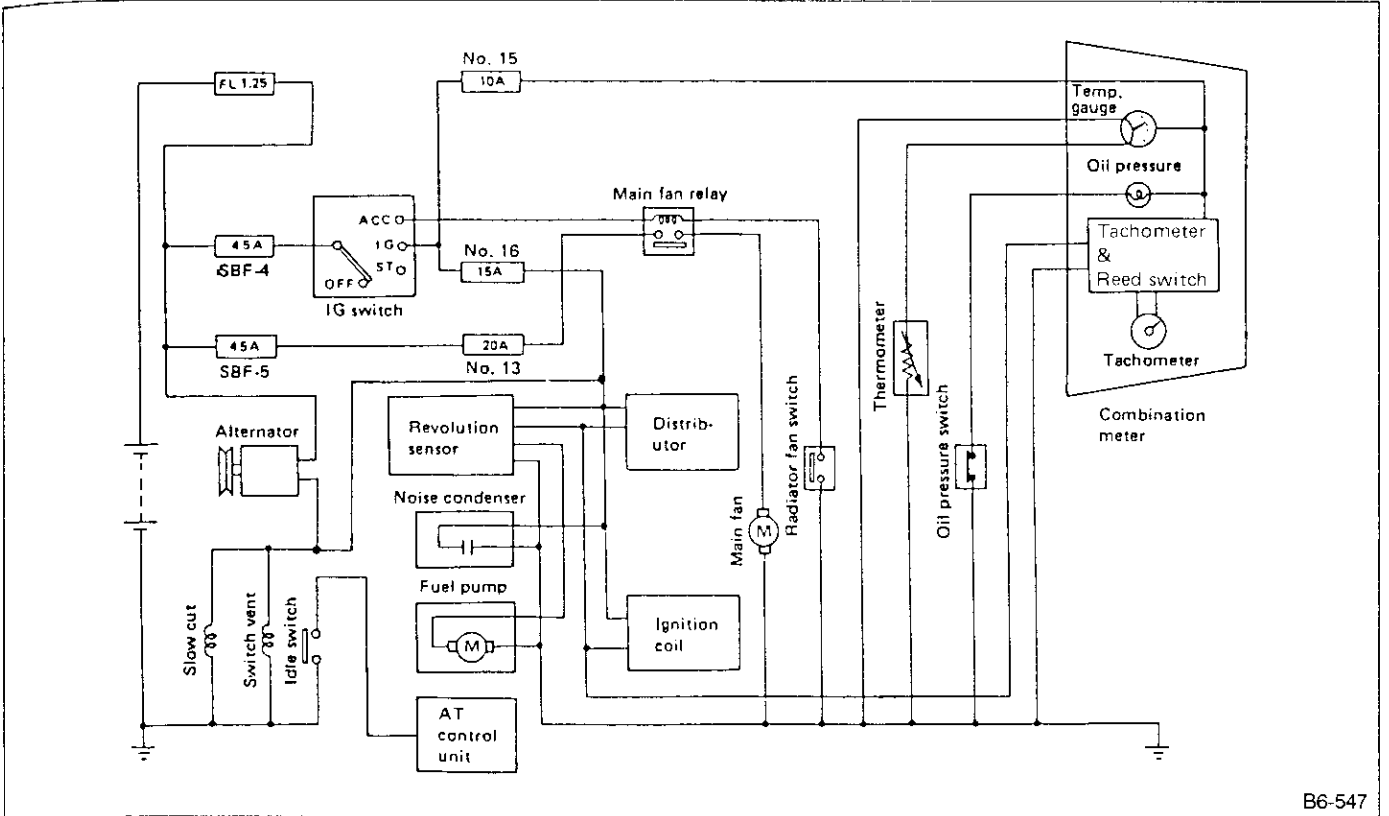


Fig. 19

B6-632

3. CARBURETOR model



B6-547

Fig. 20

4. MPFI model (TURBO)

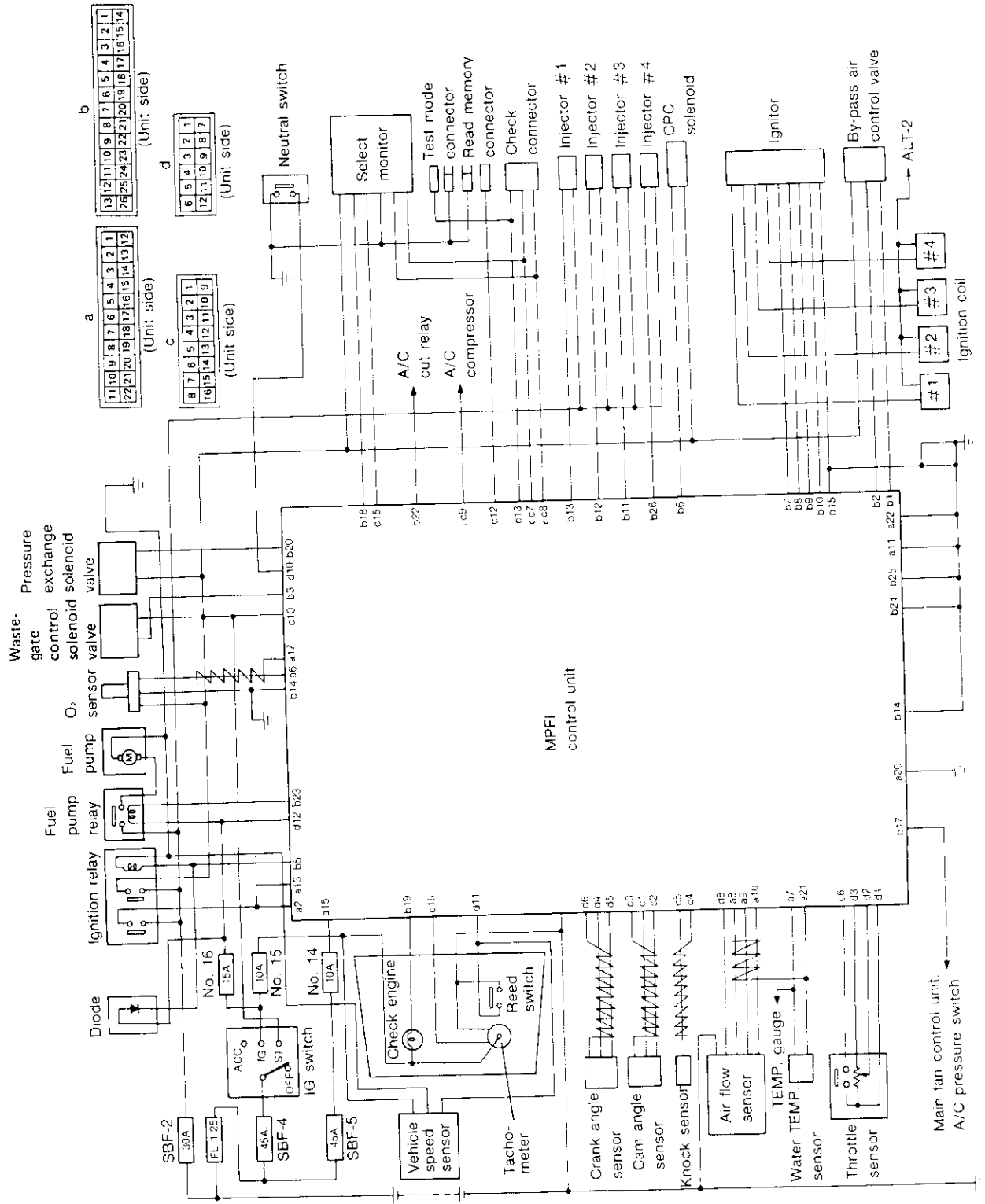


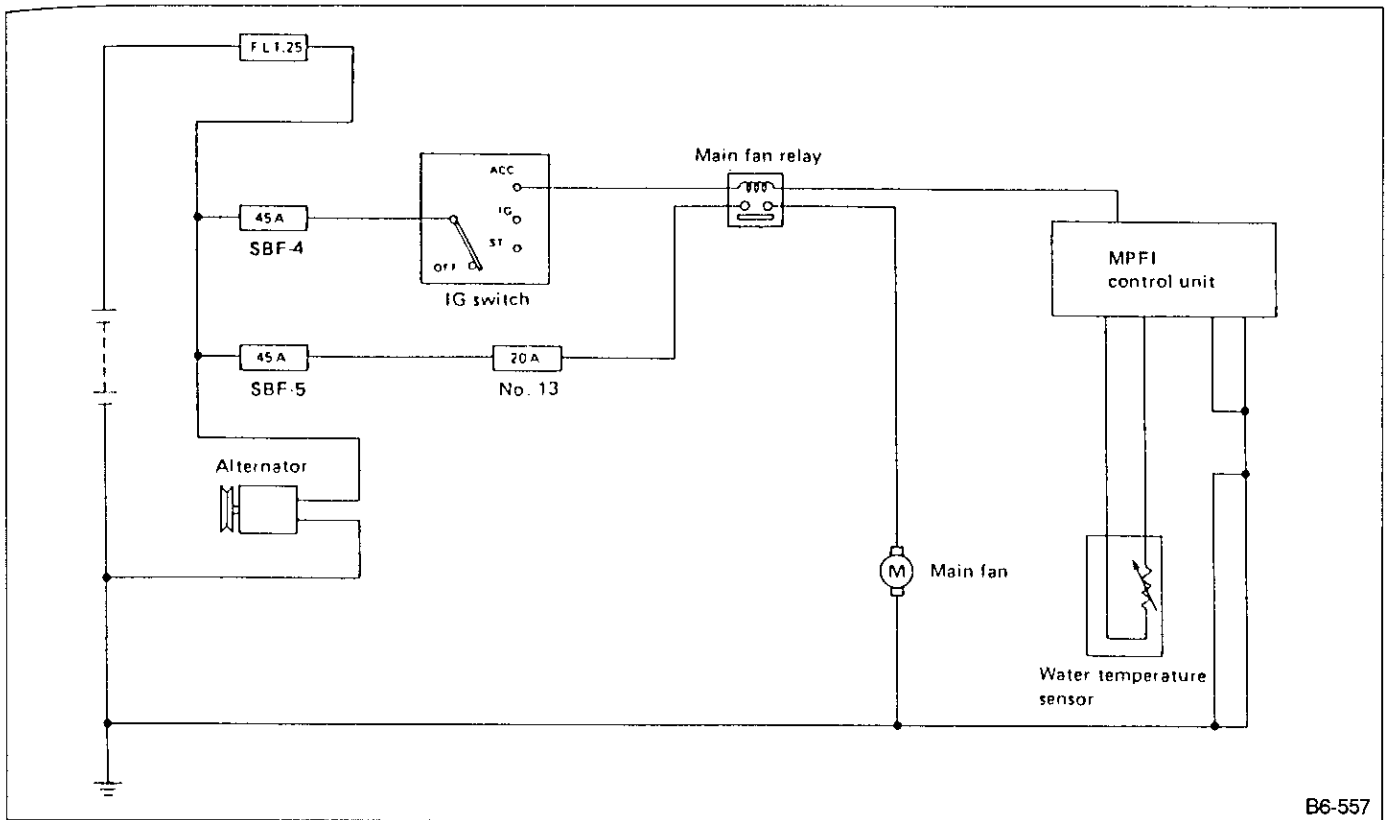
Fig. 21

B6-786

5. Cooling Fan

A: SCHEMATIC

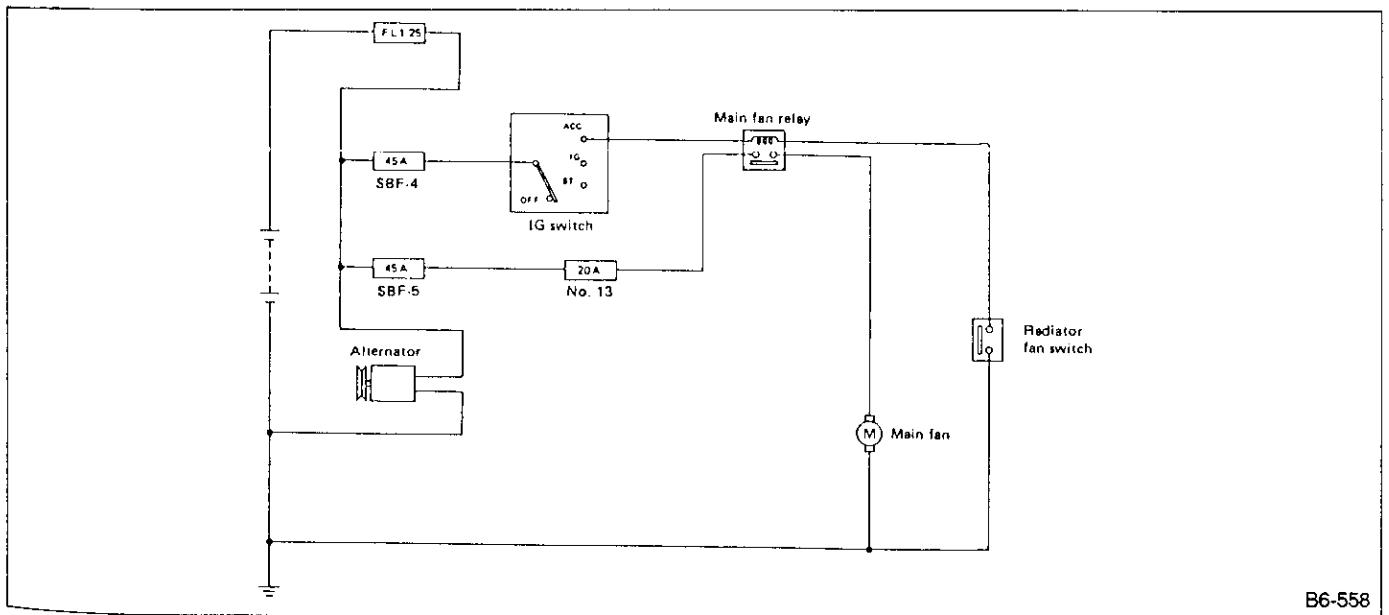
1. MPFI/SPFI model



B6-557

Fig. 22

2. CARBURETOR model

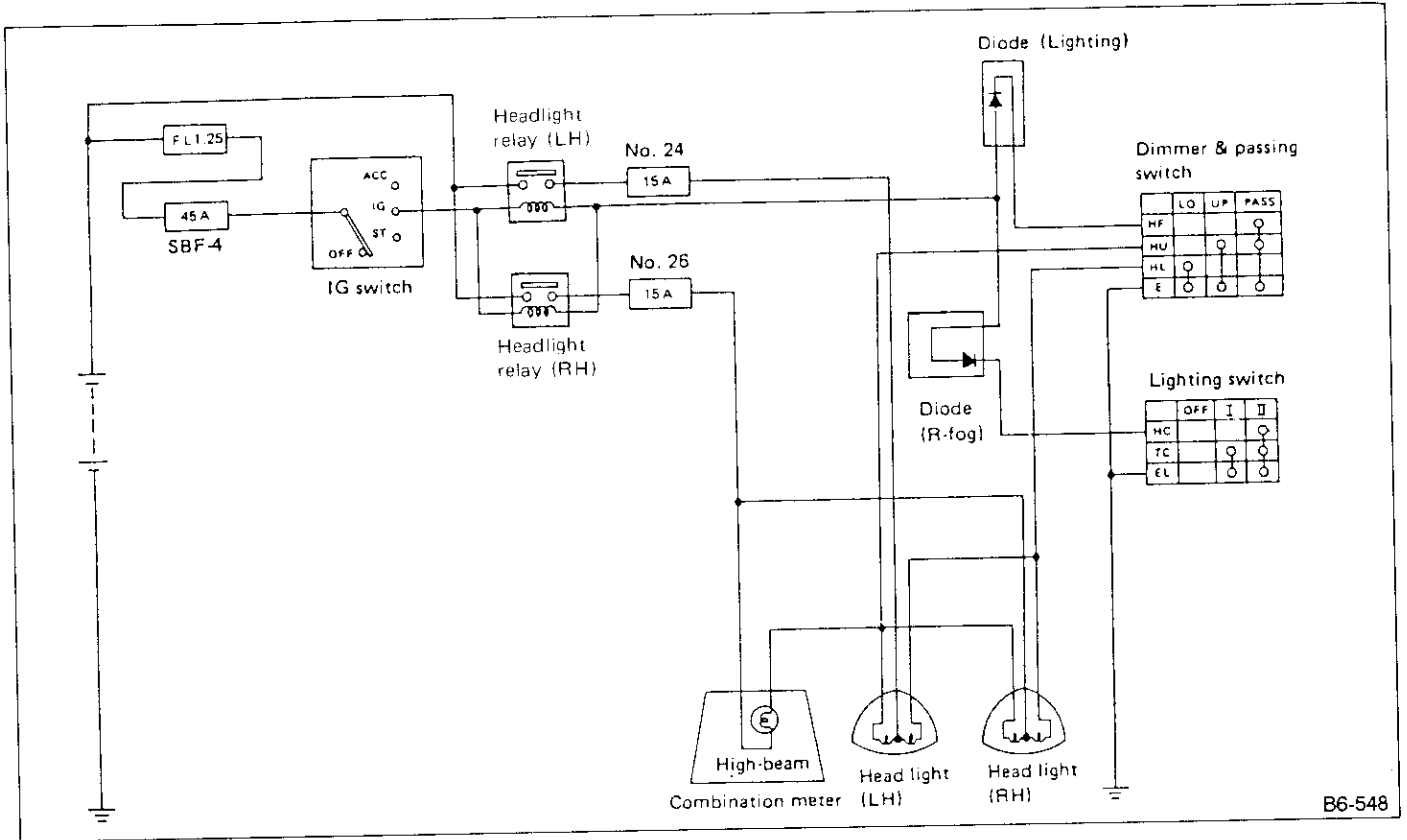


B6-558

Fig. 23

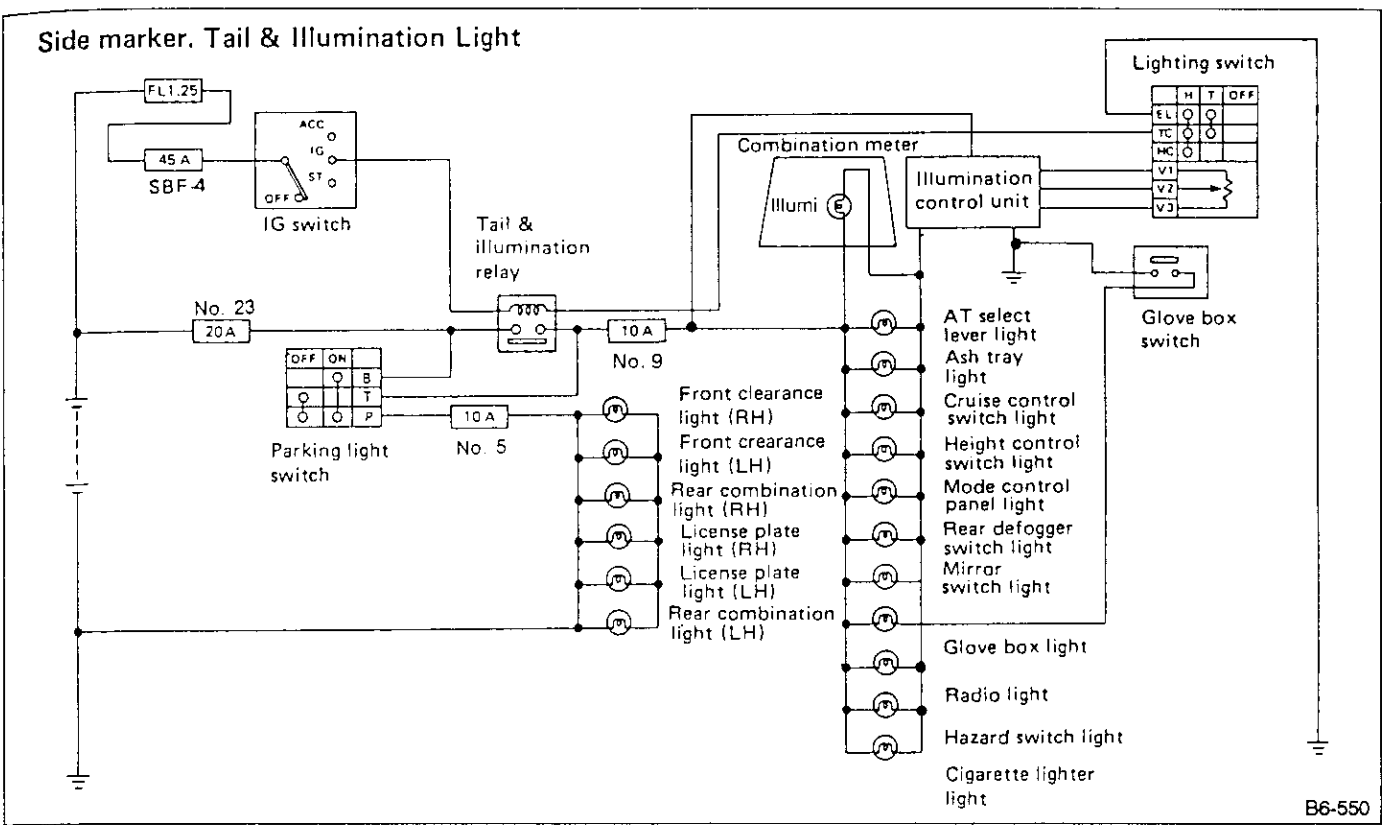
6. Lighting

A: SCHEMATIC



B6-548

Fig. 24



B6-550

Fig. 25

B: ADJUSTMENT**1. HEADLIGHT AIMING**

Open front hood and turn two bolts used for headlight aiming adjustment.

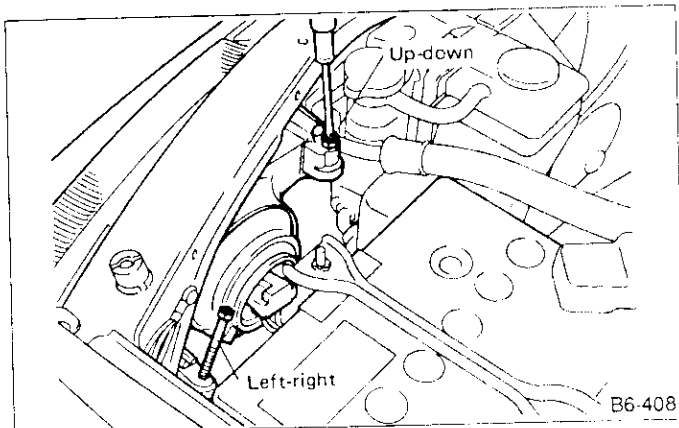


Fig. 26

C: REMOVAL AND INSTALLATION**1. HEADLIGHT AND FRONT COMBINATION LIGHT**

- 1) Remove front grille and disconnect connector from headlight.
- 2) Remove screws which secure front turn signal light.
- 3) Remove front turn signal light while disconnecting connector.

When installing, securely fit clip (on fender side) into locating boss (on turn signal light).

- 4) Remove screws and nuts which secure headlight, and remove headlight.

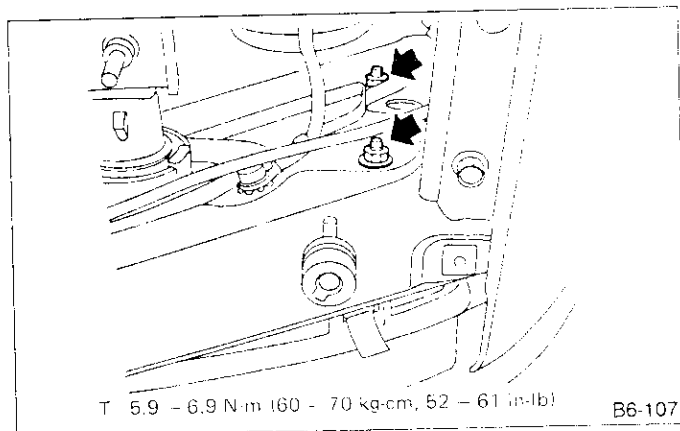


Fig. 27

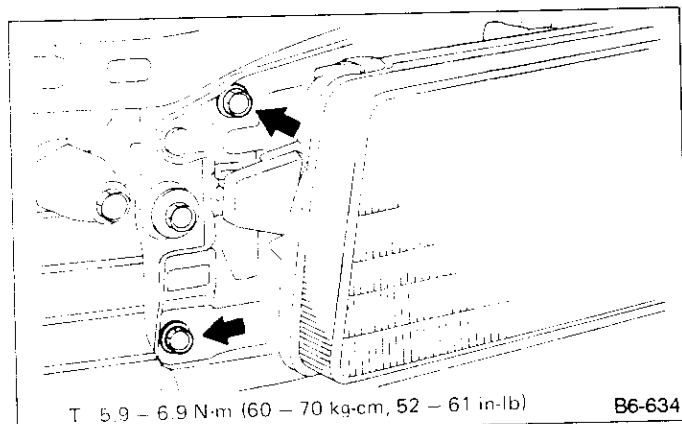


Fig. 28

2. FRONT TURN SIGNAL LIGHT

- 1) Remove lens and screws.
- 2) While removing turn signal light, disconnect connector.

3. REAR COMBINATION LIGHT

- 1) Remove light cover (Wagon). Remove trunk's rear trim (Sedan).
- 2) Remove nuts and disconnect connector.

Tightening torque:

5.9 — 6.9 N·m
(60 — 70 kg-cm, 52 — 61 in-lb)

- 3) Attach adhesive cloth tape to body area around rear combination light.
- 4) Using a standard screwdriver, carefully pry rear combination light off and away from the front of vehicle.

a. Do not pry rear combination light forcefully as this may scratch vehicle body.

b. Remove all traces of adhesive tape from body before installation.

c. Attach butyl rubber tape to back of rear combination light before installing rear combination light on body for sealing purposes.

4. LICENSE PLATE LIGHT

- 1) Remove screws which secure license plate light.
- 2) While removing license plate light, disconnect connector.

5. GLOVE BOX LIGHT AND SWITCH

- 1) Remove glove box.
- 2) Remove screws which secure striker ASSY, and remove striker ASSY.
- 3) Disconnect light ASSY connector. Remove screws and light ASSY.
- 4) Disconnect connector from switch. While pushing pawl on switch forward of switch, remove switch off.

6. ASH TRAY ILLUMINATION LIGHT

- 1) Remove ash tray.
- 2) Remove screws which secure ash tray holder, and remove ash tray holder.

Three screws are used. The screw located far back in the ash tray holder need only be loosened.

- 3) While removing ash tray holder, disconnect connector.

7. SELECTOR LEVER ILLUMINATION LIGHT

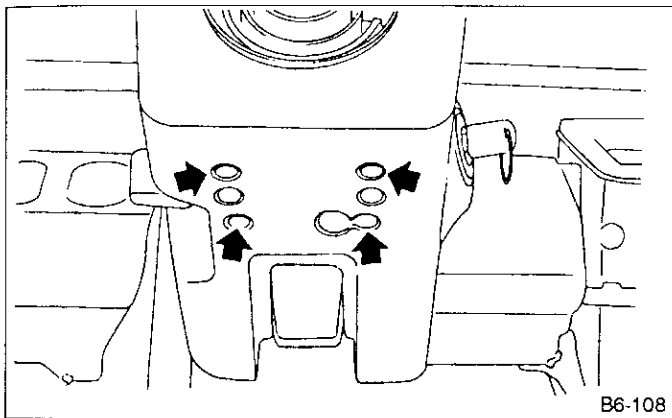
- 1) Remove indicator ASSY. (Ref. to [3-3].)
- 2) Remove screws from back of illumination light, and remove illumination light.

8. ILLUMINATION CONTROL UNIT

(Ref. to [6-2] No. W9B3.)

9. COMBINATION SWITCH

- 1) Remove steering wheel. (Ref. to [4-3].)
- 2) Remove screws which secure upper column cover to lower column cover.



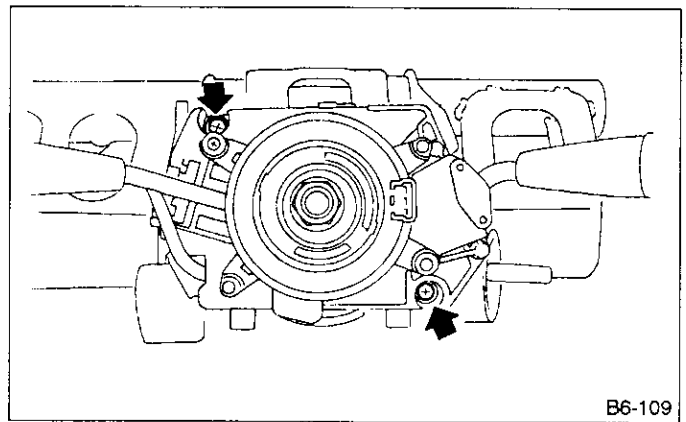
B6-108

Fig. 29

- 3) Remove screws which secure bracket cover, and remove bracket cover.

When installing bracket cover, ensure that harness is not caught by adjacent parts.

- 4) Disconnect connector from body harness, and undo hold down band.
- 5) Remove screws which secure switch, and remove switch.



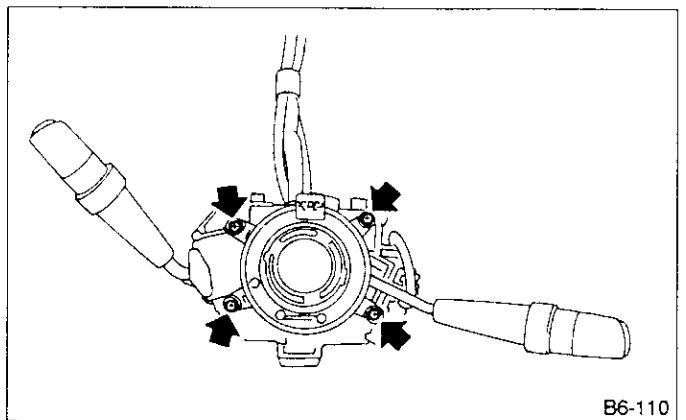
B6-109

Fig. 30

D: DISASSEMBLY AND ASSEMBLY

1. COMBINATION SWITCH

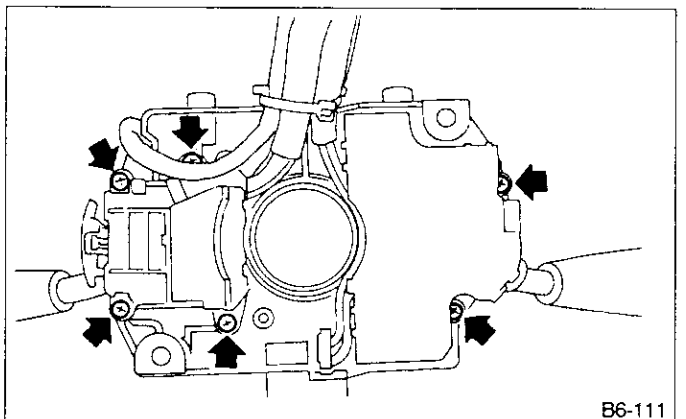
- 1) Remove screws which secure slip ring to combination switch, and remove slip ring.



B6-110

Fig. 31

- 2) Remove screws which secure lighting switch ASSY and wiper and washer switch ASSY. Remove both switch ASSY's.



B6-111

Fig. 32

ASSEMBLY is in the reverse order of disassembly.

E: INSPECTION

1. COMBINATION SWITCH (ON-CAR)

- 1) Remove instrument panel lower cover.
- 2) Remove lower column cover.
- 3) Unfasten holddown band which secures harness, and disconnect connectors from body harness.

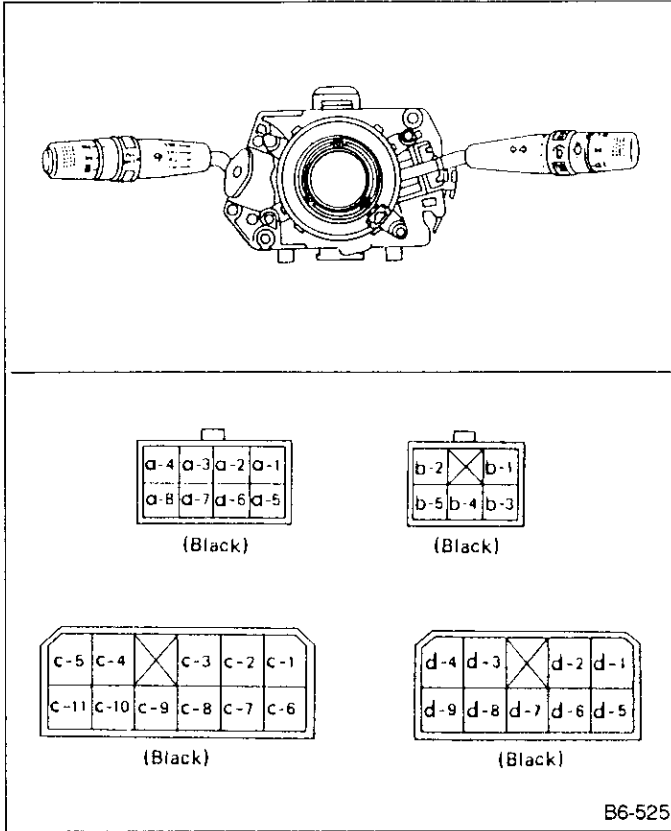


Fig. 33
Move combination switch to respective positions and check continuity between terminals as indicated in the following tables.

LIGHTING SWITCH

Terminal (Wire color)	c-1 (W)	c-2 (W)	c-3 (R)
Switch position			
OFF			
Tail	○	○	
↓	○	○	
Head	○	○	○

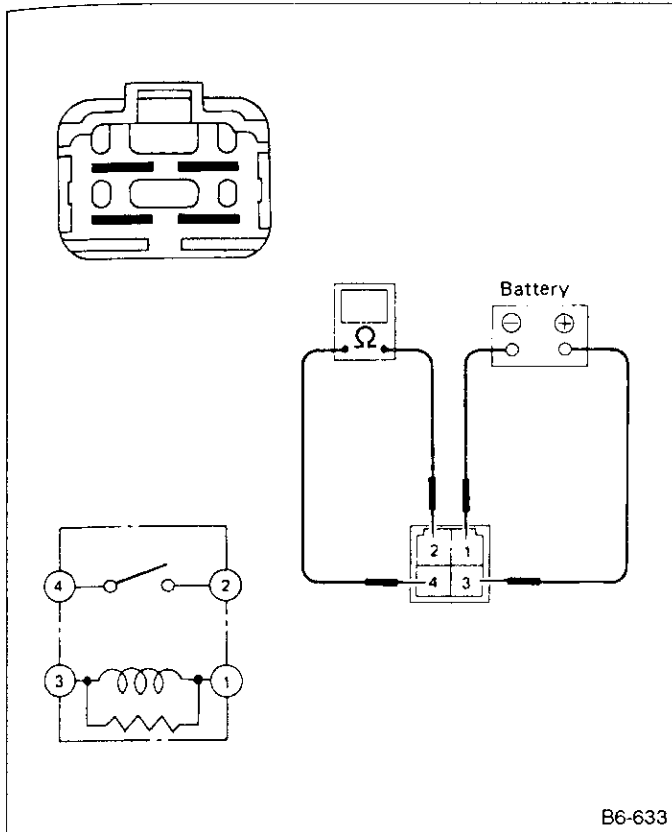
PARKING LIGHT SWITCH

Terminal (Wire color)	c-10 (R)	c-11 (RG)	c-9 (RW)
Switch position			
OFF	○	○	
↓	×		×
ON		○	○

DIMMER AND PASSING SWITCH

Terminal (Wire color)	a-3 (B)	a-2 (RB)	a-1 (RY)	a-4 (YR)
Switch position				
Flash	○		○	○
↓	○	○	○	
Low beam	○	○		
↓	○	○	○	
High beam	○		○	

2. HEADLIGHT RELAY



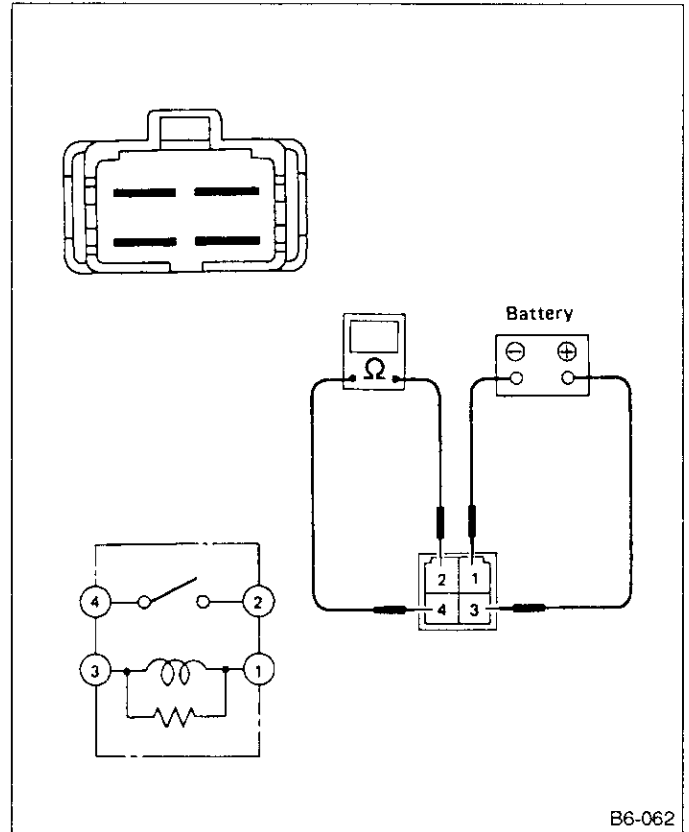
B6-633

Fig. 34

Check continuity between terminals (indicated in table below) when terminal (3) is connected to battery and terminal (1) is grounded.

When current flows	Between terminals (2) and (4)	Continuity exists.
When current does not flow	Between terminals (2) and (4)	Continuity does not exist.
	Between terminals (1) and (3)	Continuity exists.

3. TAIL AND ILLUMINATION RELAY



B6-062

Fig. 35

Check continuity between terminals (indicated in table below) when terminal (3) is connected to battery and terminal (1) is grounded.

When current flows	Between terminals (2) and (4)	Continuity exists.
When current does not flow	Between terminals (2) and (4)	Continuity does not exist.
	Between terminals (1) and (3)	Continuity exists.

7. Room Light and Door Switch

A: SCHEMATIC

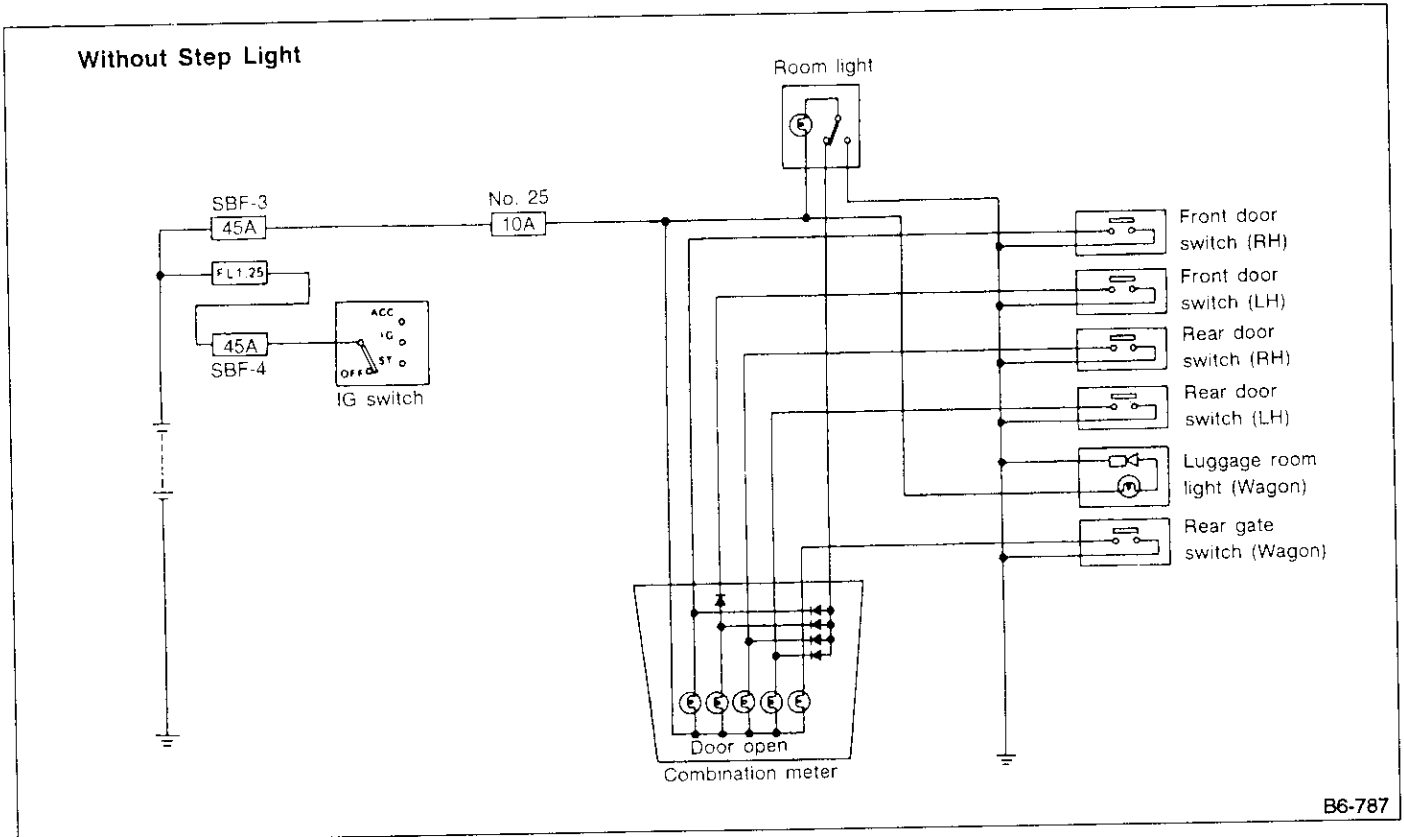


Fig. 36

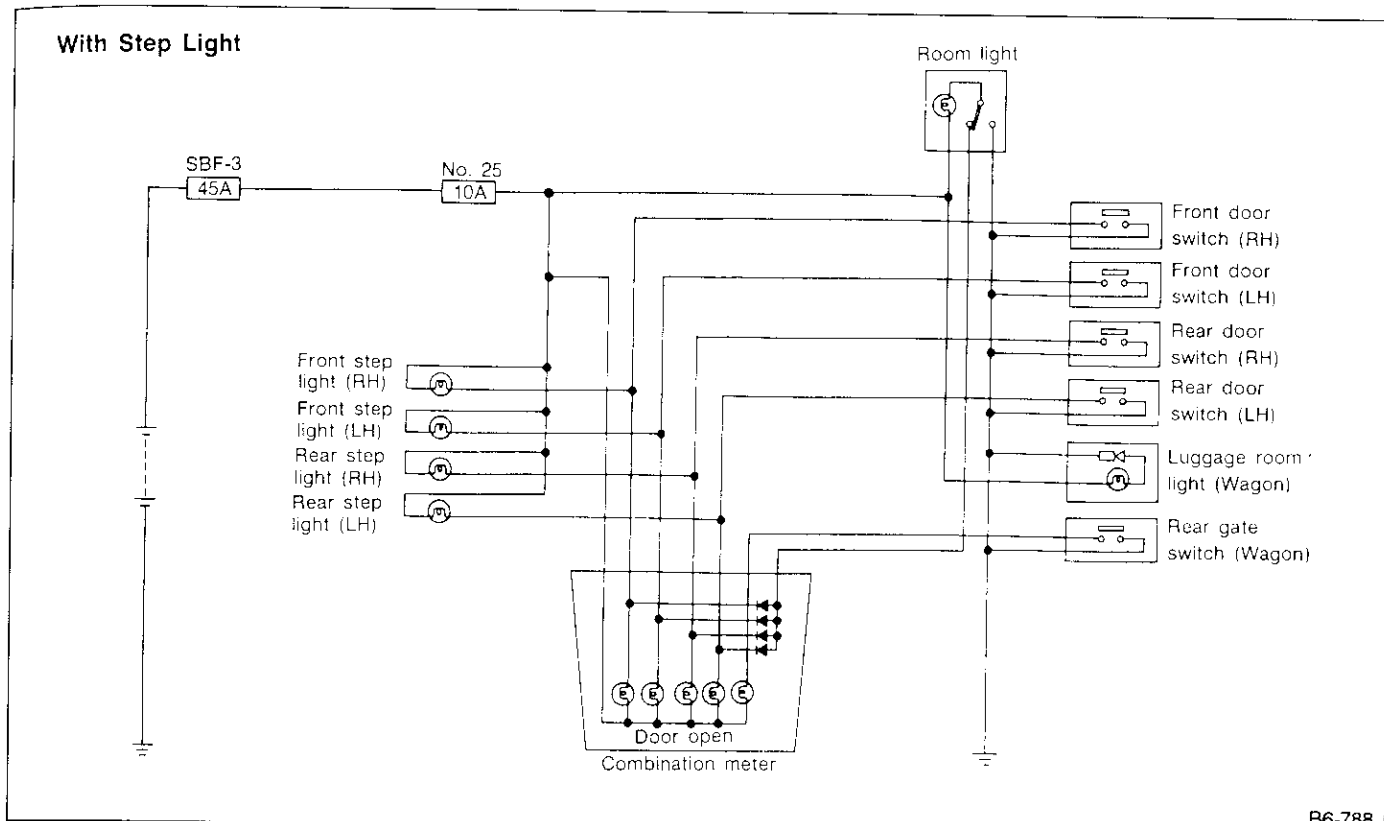


Fig. 37

B: REMOVAL AND INSTALLATION

C: INSPECTION

1. DOOR SWITCH

- 1) Remove trim panel.
- 2) Disconnect connector.
- 3) While pushing door switch pawl using a standard screwdriver from the compartment side, push door switch out.
- 4) Remove cover.

2. REAR GATE SWITCH

(Ref. to [5-2].)

3. ROOM LIGHT

- 1) Remove lens and screws.
- 2) While removing room light, disconnect connector.

4. LUGGAGE ROOM LIGHT

- 1) Remove lens and screws.
- 2) While removing luggage room light, disconnect connector.

1. DOOR SWITCH

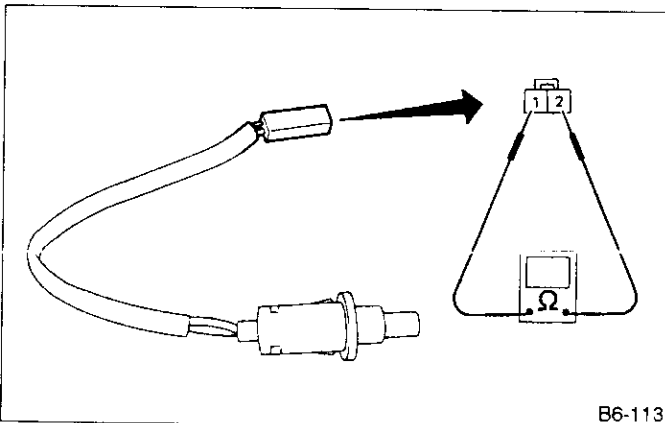


Fig. 38

Check continuity between terminals.

Terminal	1	2
Switch position		
Open (ON)	○	○
Push in (OFF)		

2. REAR GATE SWITCH

Move latch and check continuity between terminals.

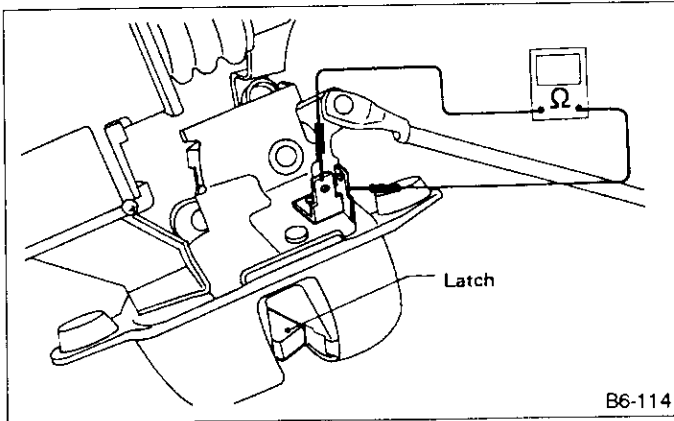
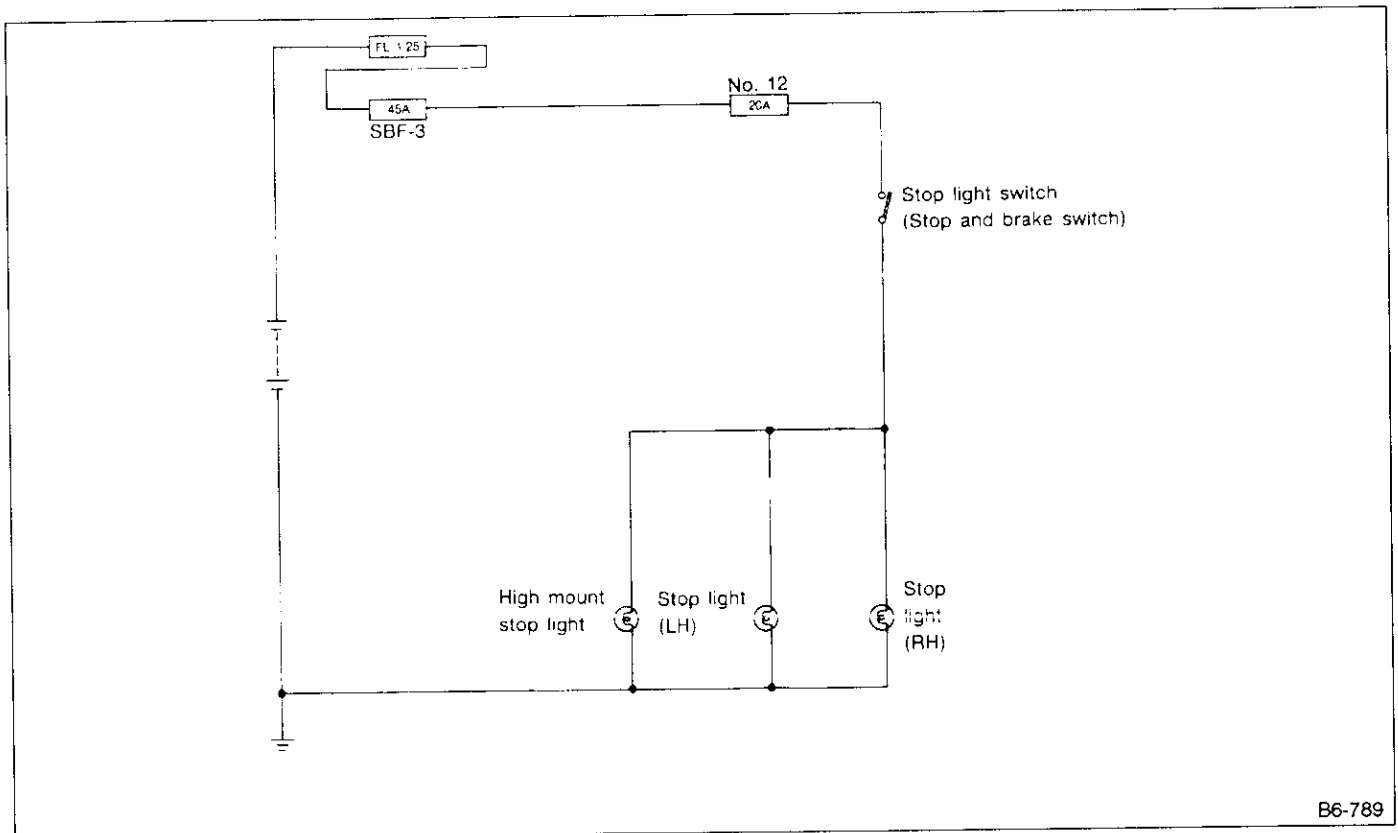


Fig. 39

8. Stop Light**A: SCHEMATIC**

B6-789

Fig. 40

B: REMOVAL AND INSTALLATION**1. STOP LIGHT SWITCH**

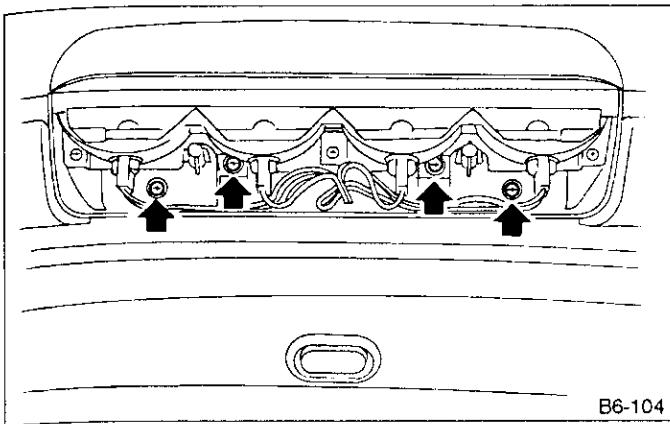
⟨Ref. to [4-5].⟩

2. STOP AND BRAKE SWITCH

⟨Ref. to [4-5].⟩

3. HIGH MOUNT STOP LIGHT (WAGON)

- 1) Remove cap.
- 2) Remove screws and cover.
- 3) Remove screws which secure stop light. While disconnecting connector, remove stop light.



B6-104

Fig. 41

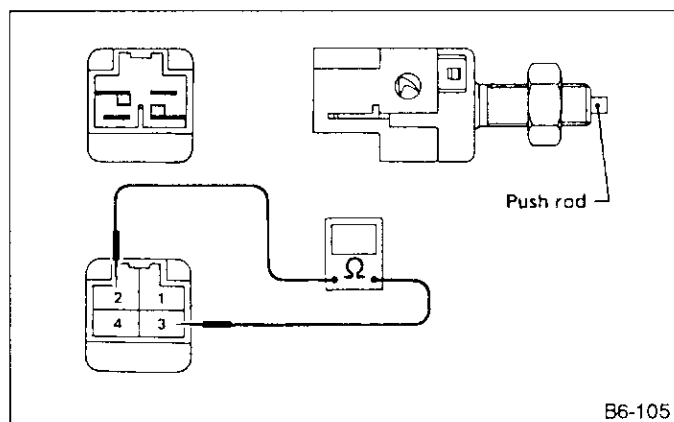
4. HIGH MOUNT STOP LIGHT (SEDAN)

- 1) Disconnect connector.
- 2) Remove screws which secure stop light to rear shelf trim panel, and remove stop light.

C: INSPECTION

**1. STOP AND BRAKE SWITCH
(With cruise control)**

- 1) Check continuity between terminals when push rod is pushed in 1.5 to 3 mm (0.059 to 0.118 in) from end of outer case.



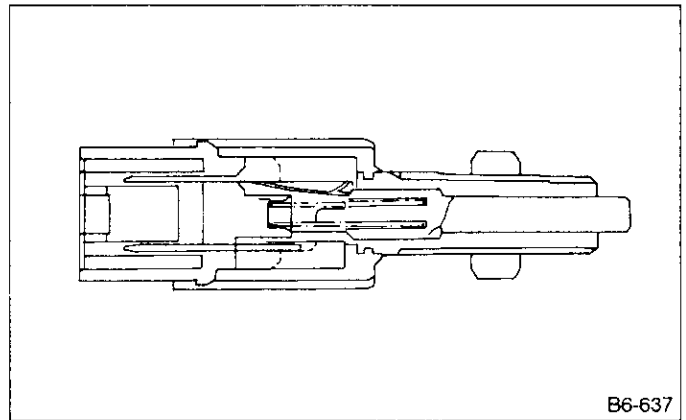
B6-105

Fig. 42

Terminal	1	2	3	4
Switch position				
When push rod is pushed in	○	—		○
When push rod is released		○	—	○

2. STOP LIGHT SWITCH

- 1) Check continuity between terminals when push rod is pushed in 4 to 4.5 mm (0.157 to 0.177 in) from end of outer case.



B6-637

Fig. 43

Terminal	1	2
Switch position		
When push rod is pushed in		
When push rod is released	○	○

9. Turn Signal and Hazard Warning Light

A: SCHEMATIC

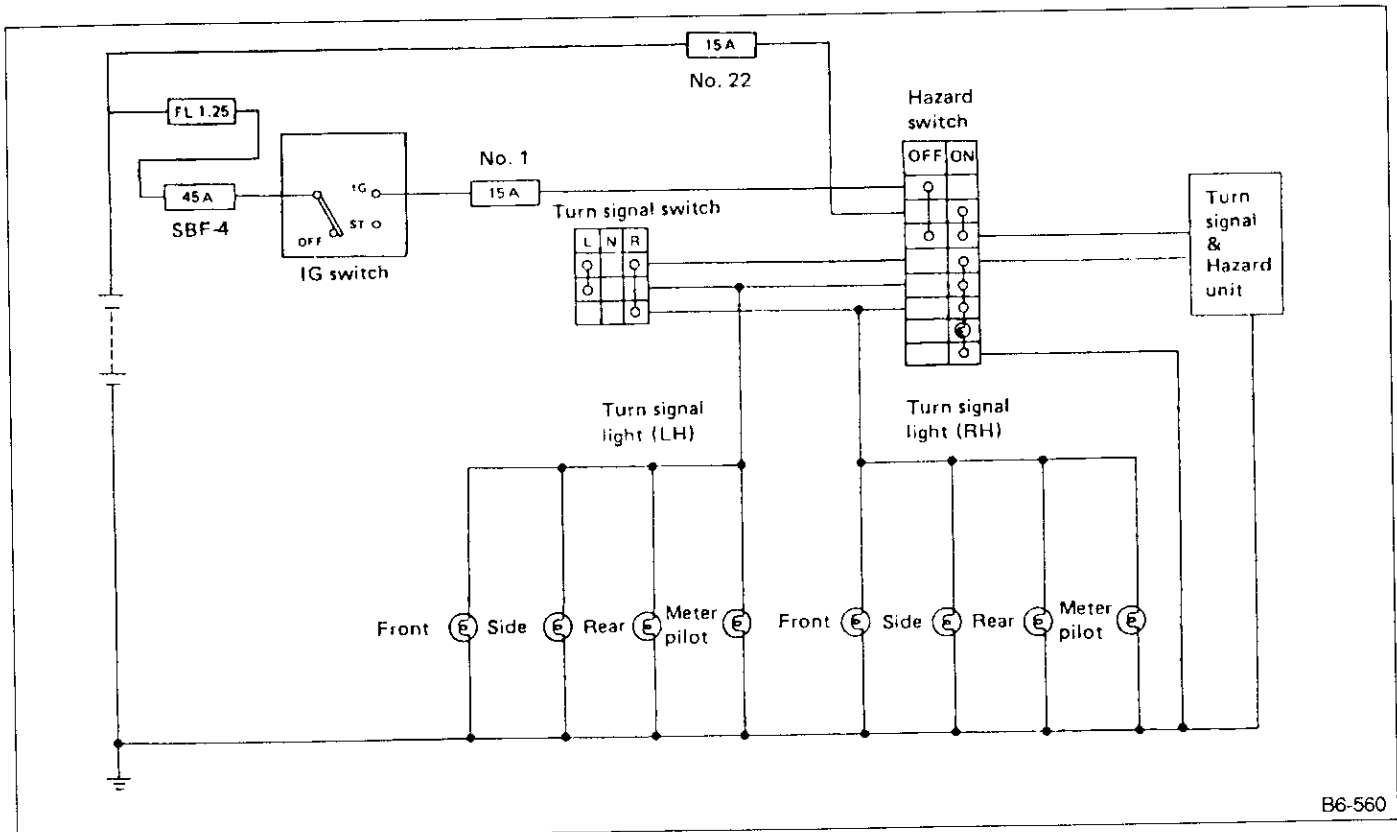


Fig. 44

B: REMOVAL AND INSTALLATION

1. COMBINATION SWITCH

(Ref. to [6-2].)

2. HAZARD SWITCH

- 1) Remove visor. (Ref. to [6-2].)
- 2) Remove screws which secure hazard switch. Remove hazard switch.

3. TURN SIGNAL AND HAZARD UNIT

- 1) Remove glove box.
- 2) Remove screws which secure frame. Remove frame.

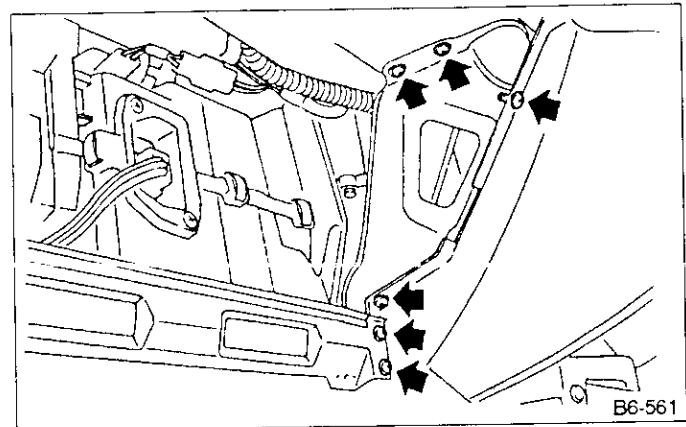


Fig. 45

- 3) Disconnect unit connector, remove screws, and remove unit and bracket as a unit.

Turn signal and hazard unit is secured to bracket together with illumination control unit.

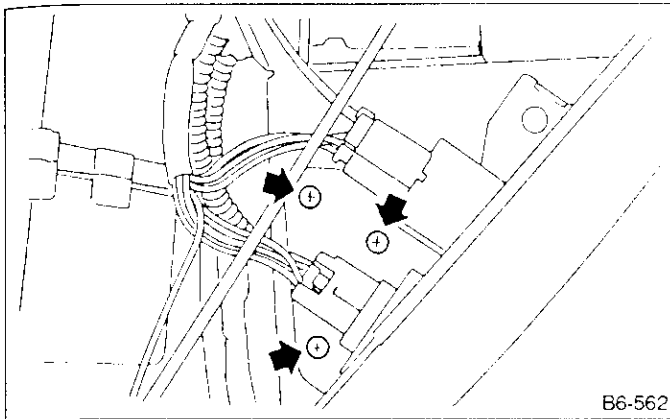


Fig. 46

Terminal (Wire color)		a-5 (GY)	a-7 (G)	a-6 (GR)
		Switch position		
Turn	L·L'	○	○	
	↓	×	—	×
	N			
	↓	×	—	×
	R·R'		○	○

2. HAZARD SWITCH

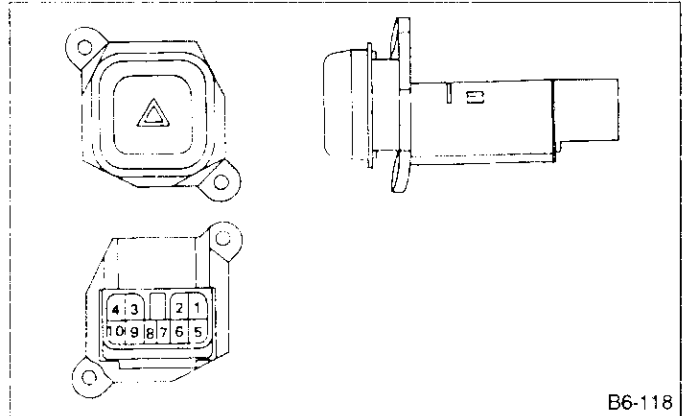


Fig. 48

Move hazard switch to each position and check continuity between terminals (indicated in table below).

Australia

	7	3	9	10	5	6	1	2
ON	○	—	○	○	○	○	○	○
OFF	○	○					○	○

Others

	7	3	9	10	5	6	4	1	2
ON	○	○	○	○	○	○	○	○	○
OFF	○	○						○	○

C: INSPECTION

1. COMBINATION SWITCH

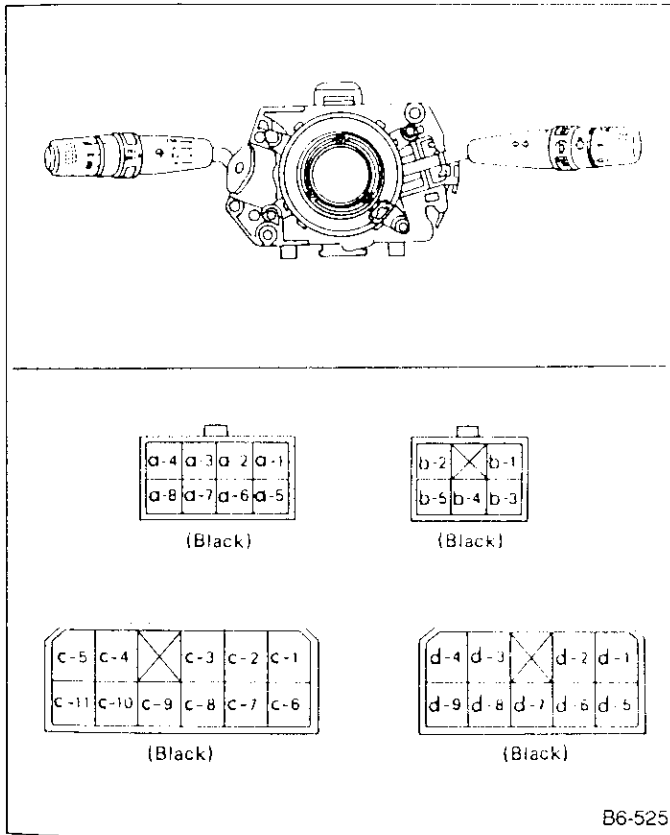


Fig. 47

Move combination switch to each position and check continuity between terminals (indicated in table below).

10. Trunk Room Light

A: SCHEMATIC

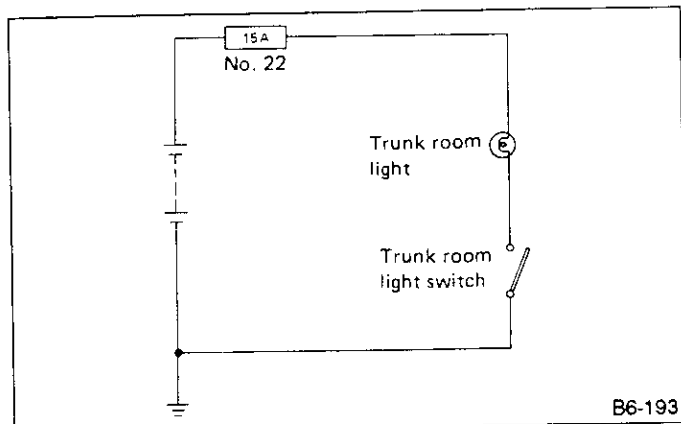
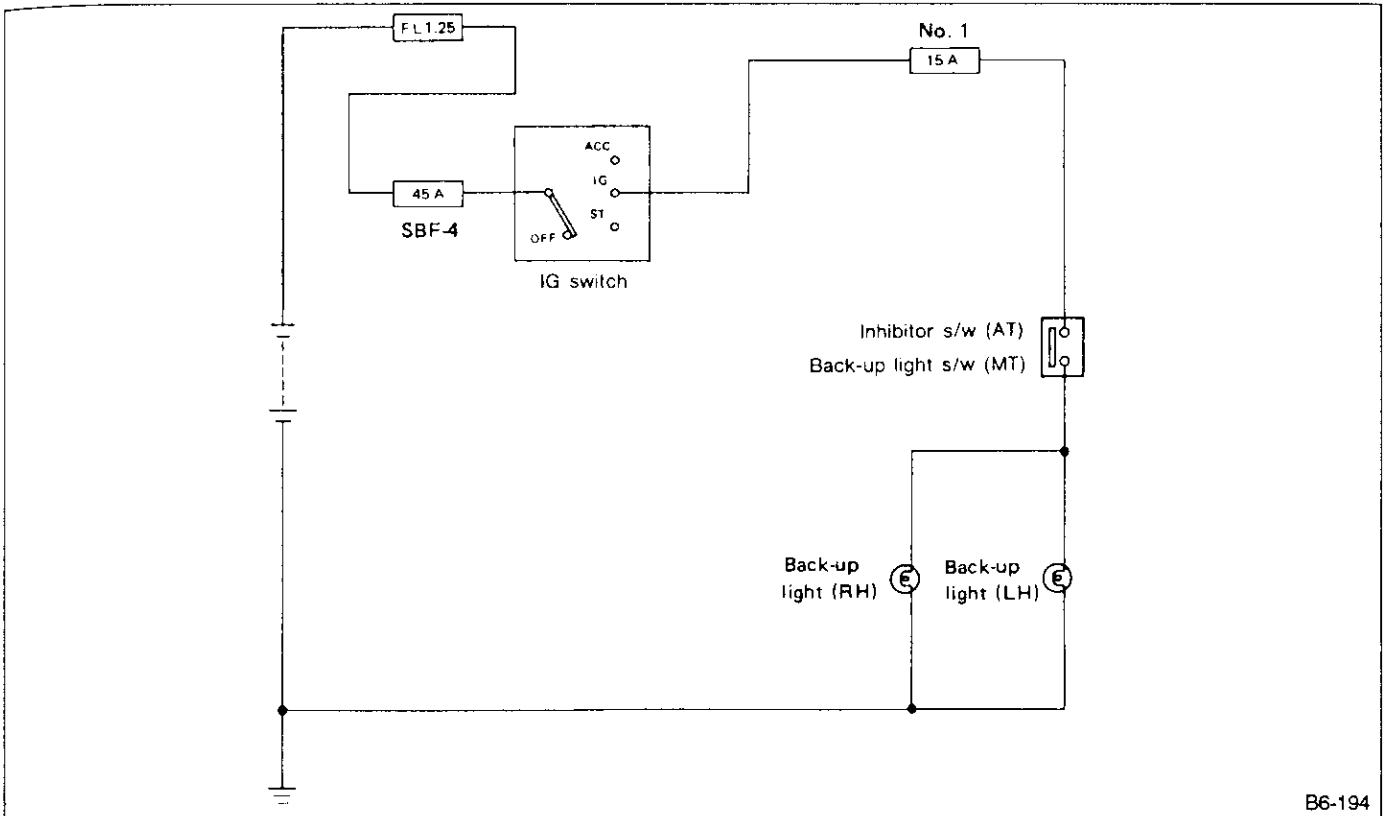


Fig. 49

11. Back-Up Light

A: SCHEMATIC



B6-194

Fig. 50

B: REMOVAL AND INSTALLATION

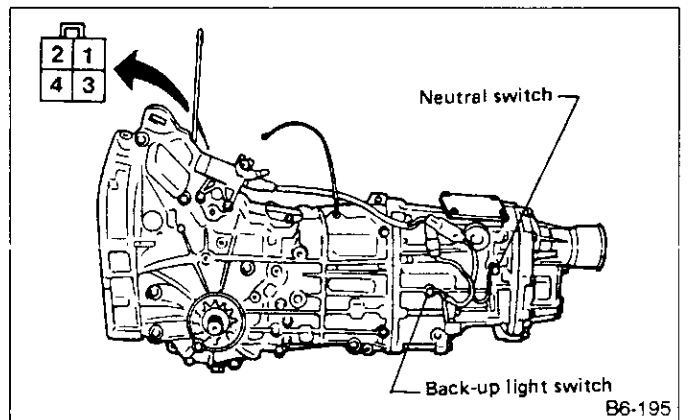
1. BACK-UP LIGHT SWITCH (MT)

<Ref. to [3-1].>

C: INSPECTION

1. BACK-UP LIGHT SWITCH (MT)

- 1) Separate transmission cord and bulkhead wiring harness.
- 2) Check for continuity between terminals (2) and (4) when shift lever is set to Reverse.



B6-195

Fig. 51

2. INHIBITOR SWITCH

<Ref. to [3-2].>

12. Rear Fog Light

A: SCHEMATIC

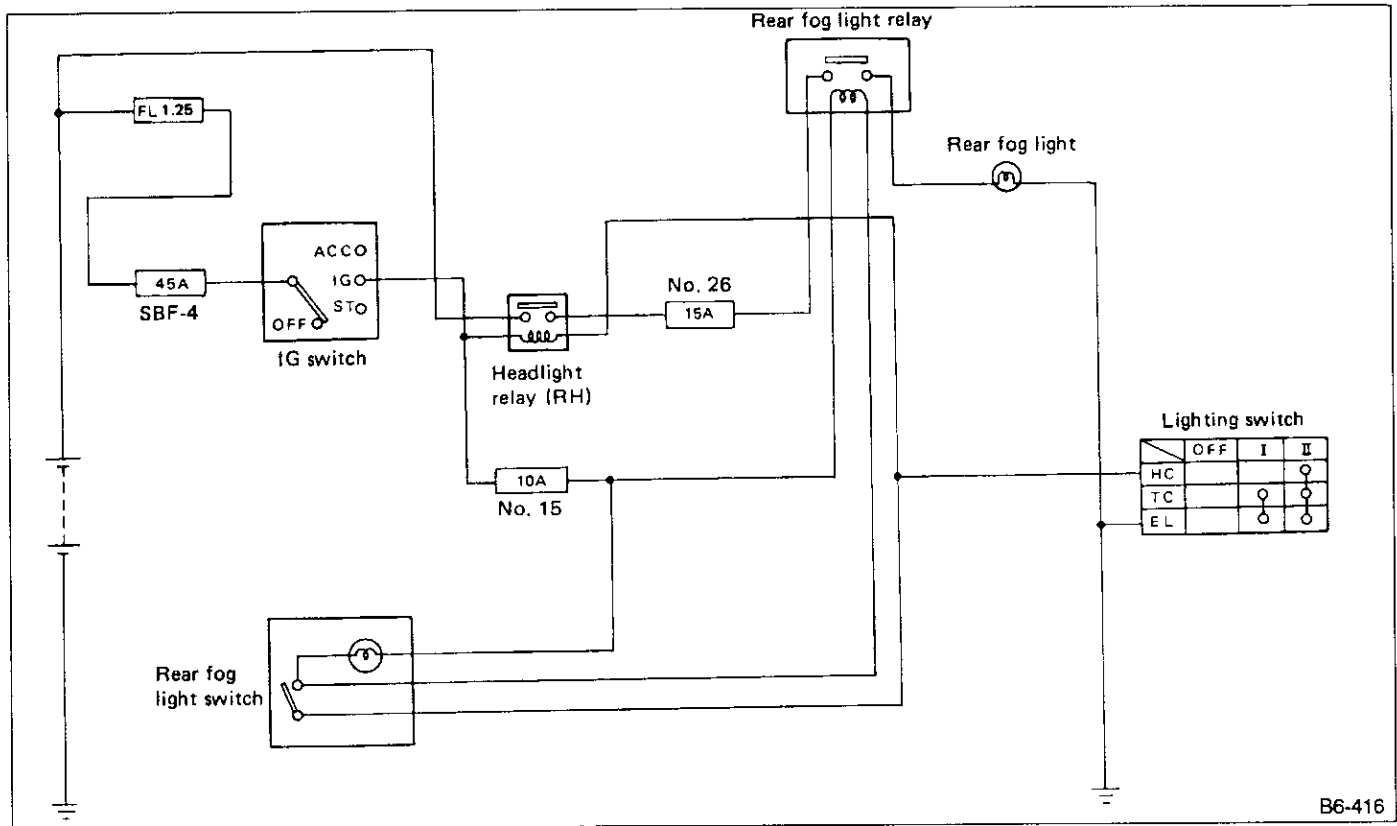


Fig. 52

B: INSPECTION

1. REAR FOG LIGHT SWITCH

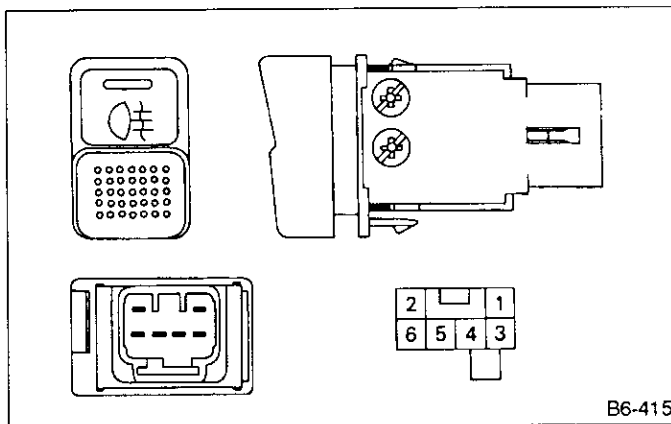


Fig. 53

Set switch to each position and check continuity between terminals (indicated in table below).

	3	5	1	4	2
ON	○	○	○	○	○
OFF				○	○

C: REMOVAL AND INSTALLATION

1. BACK-UP LIGHT SWITCH (MT)

<Ref. to [3-1].>

D: INSPECTION

1. BACK-UP LIGHT SWITCH (MT)

- 1) Separate transmission cord and bulkhead wiring harness.
- 2) Check for continuity between terminals (2) and (4) when shift lever is set to Reverse.

13. Automatic Transmission Control (4AT)

A: SCHEMATIC

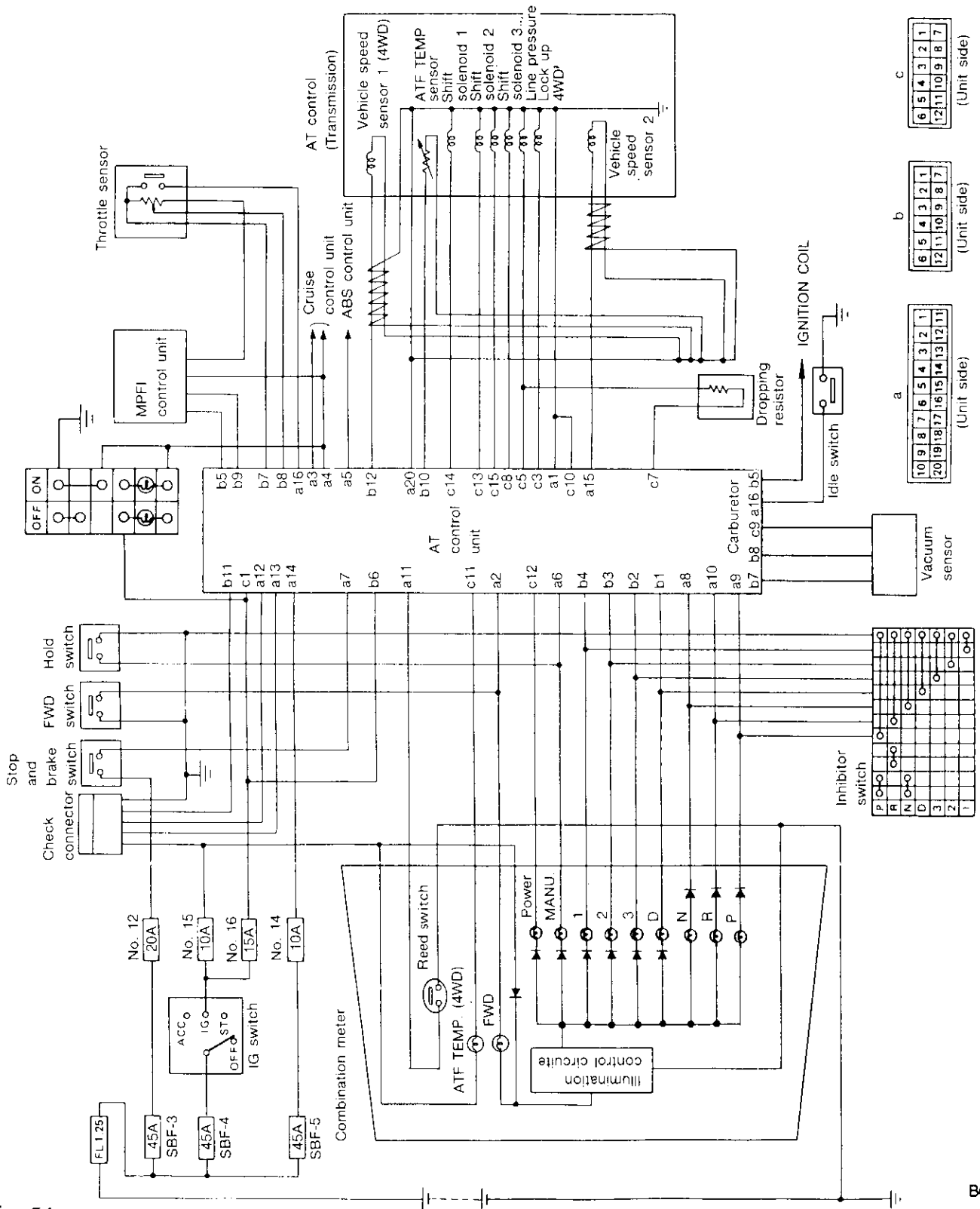


Fig. 54

B6-790

14. 4WD-MT

A: SCHEMATIC

1. Full-Time Dual range

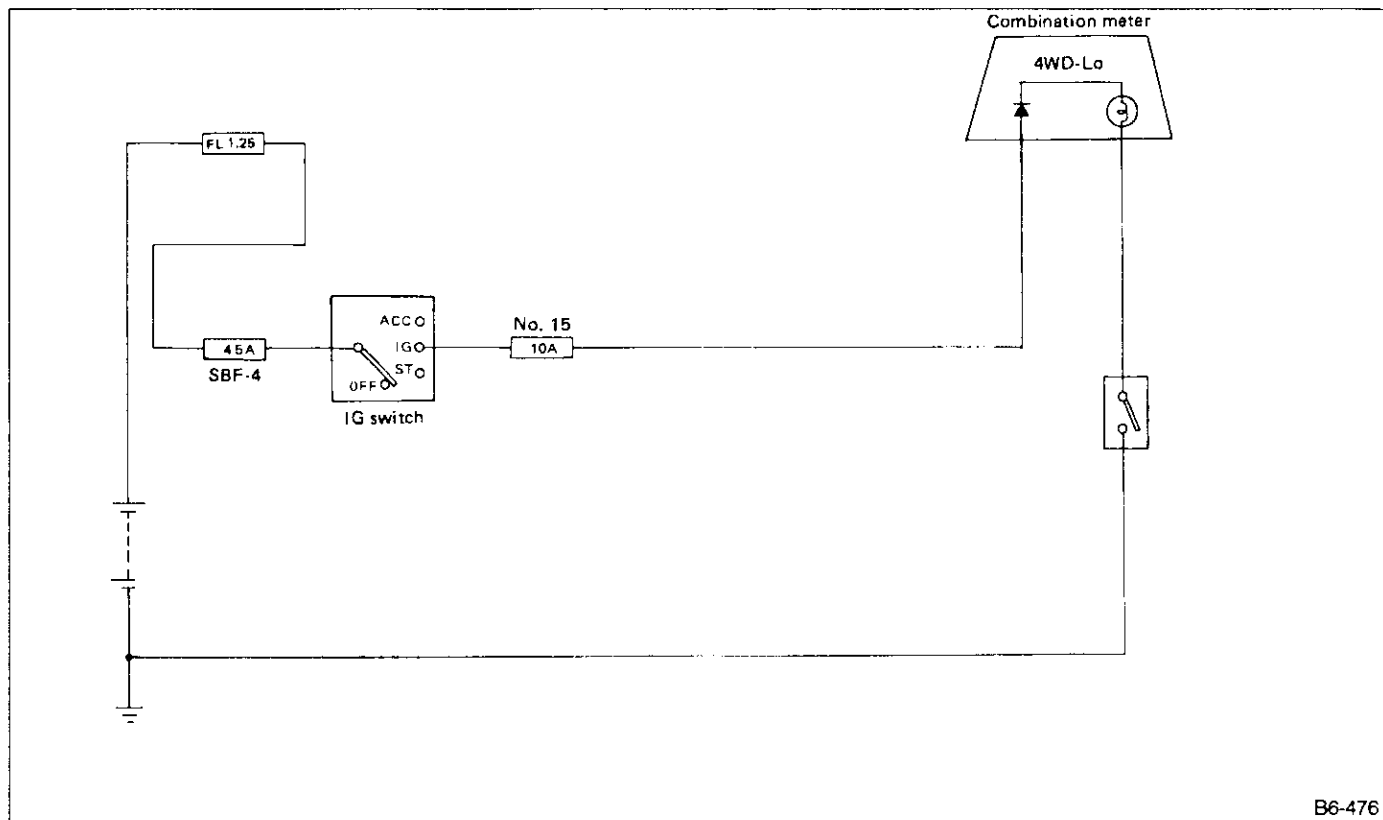
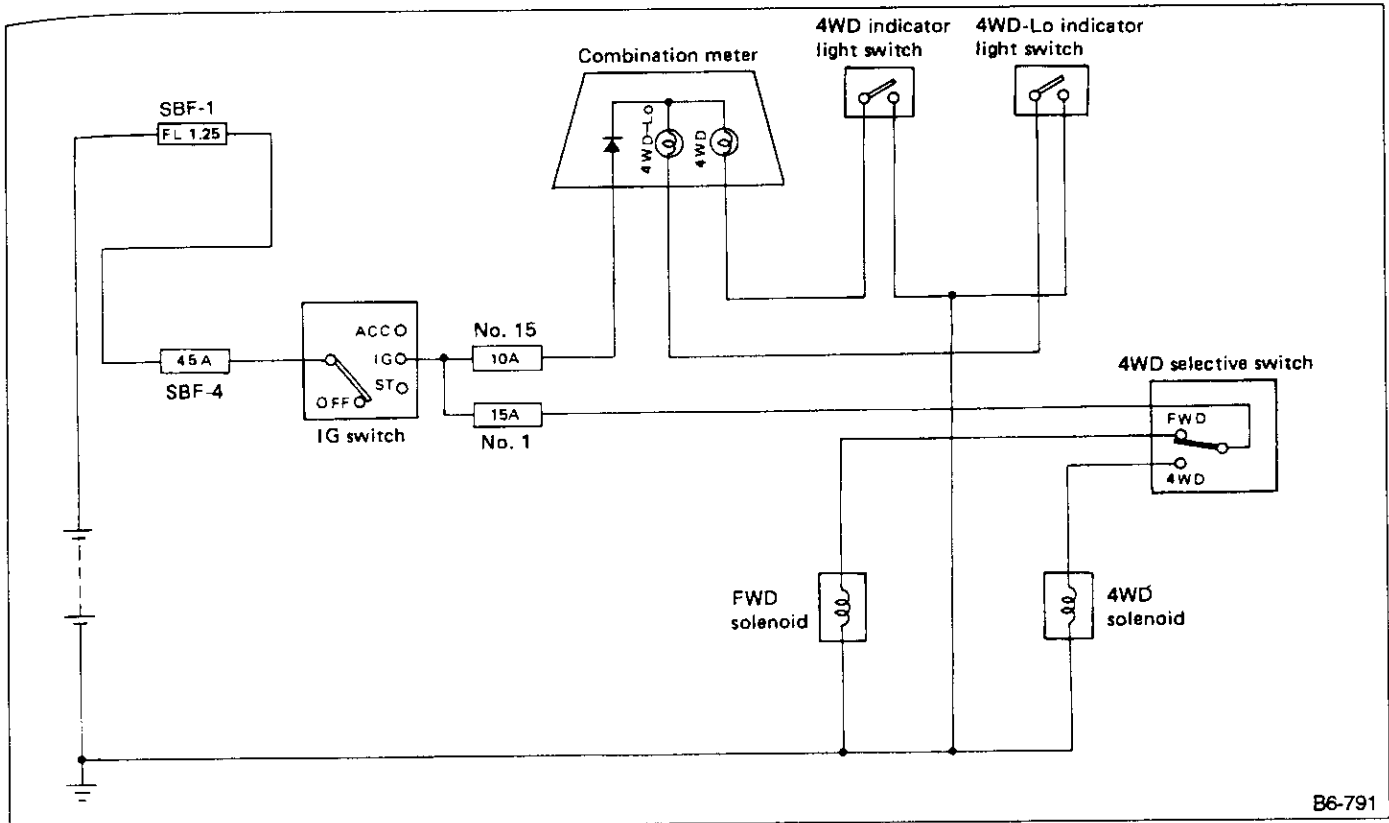


Fig. 55

B6-476

2. Part-Time Dual range

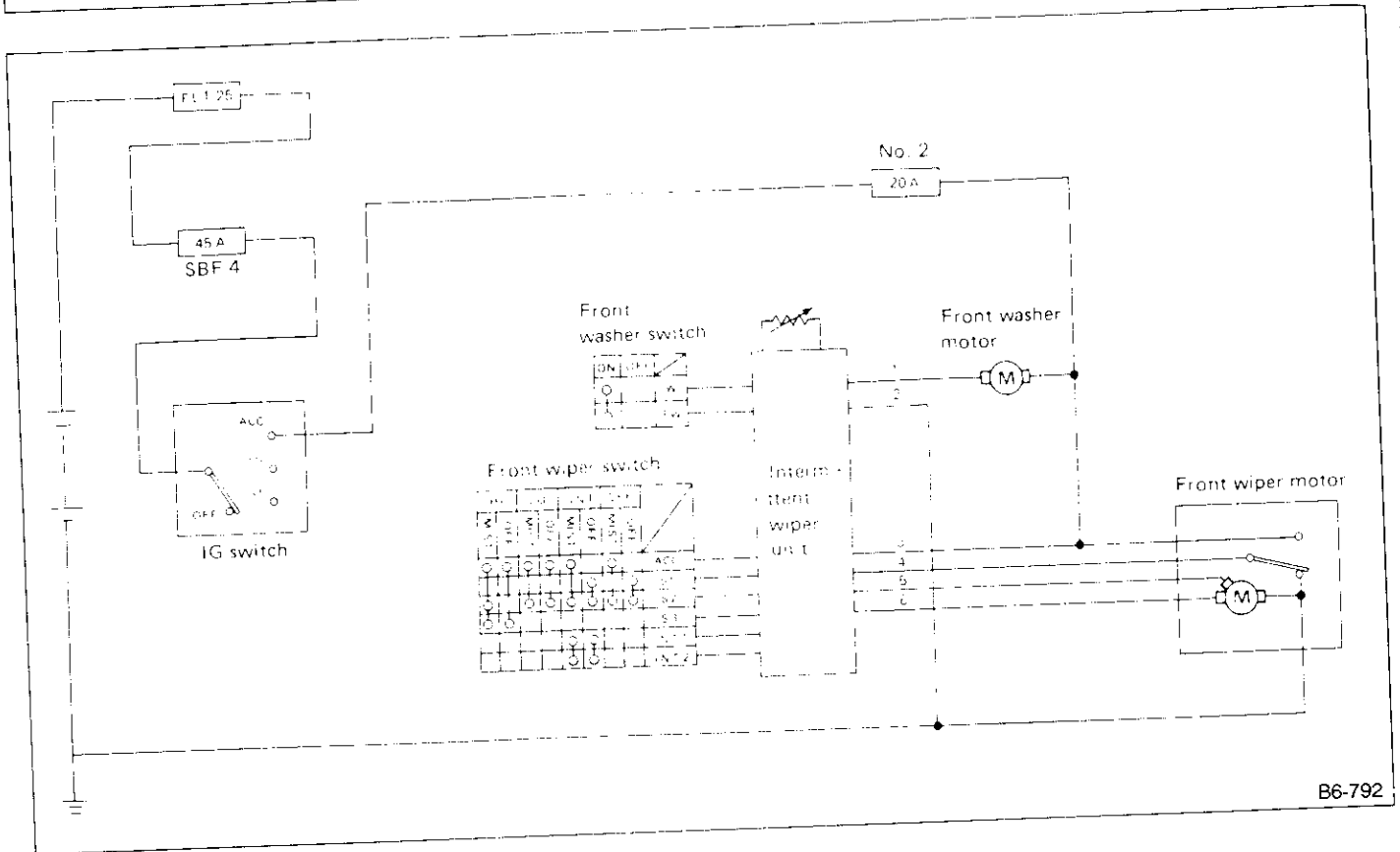


B6-791

Fig. 56

15. Front Wiper and Washer

A: SCHEMATIC



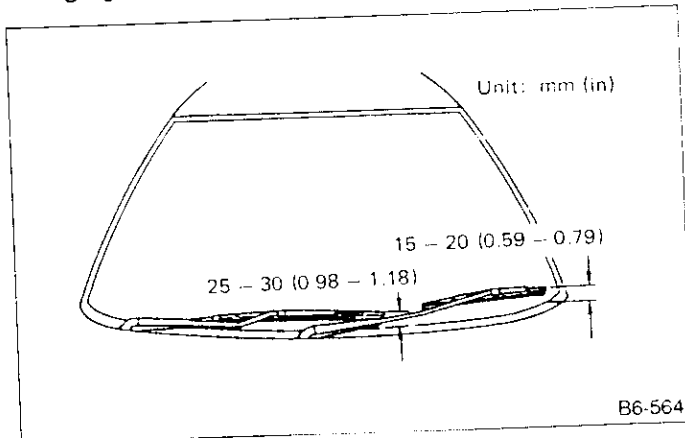
B6-792

Fig. 57

B: ON-CAR SERVICES

1. ADJUSTMENT

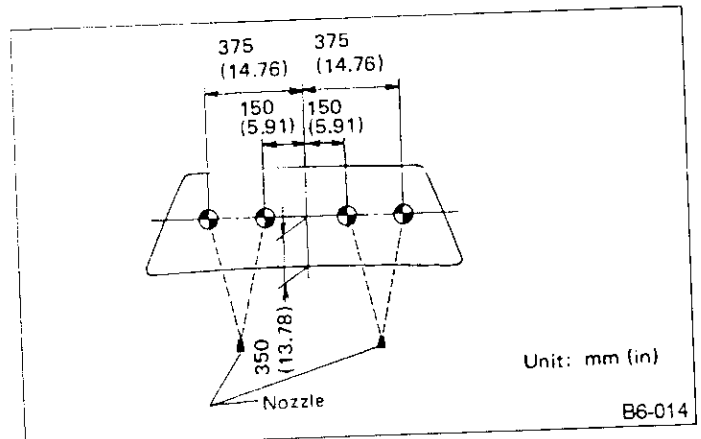
1) When wiper switch is in "OFF" position, adjust blades in original position as shown in illustration by changing wiper arm installation.



B6-564

Fig. 58

2) Adjust washer ejecting point on windshield glass as shown in illustration when car stops.



B6-014

Fig. 59

C: REMOVAL AND INSTALLATION

1. BLADE

Pull out blade from arm while pushing up clip.

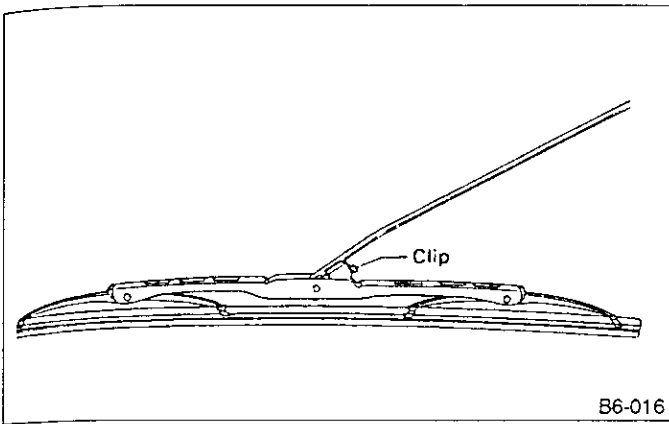


Fig. 60

2. WIPER ARM

- 1) Open front hood.
- 2) Remove cap. Remove the nut which secure wiper arm, and remove wiper arm.

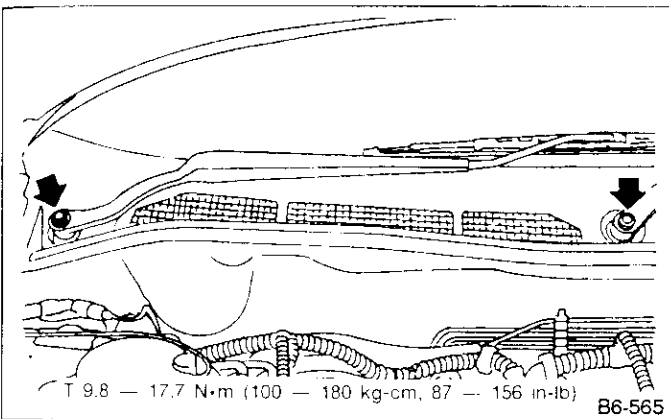


Fig. 61

3. WIPER MOTOR AND LINK

- 1) Detach weatherstrip and cowl net.
Apply silicone oil or soap water to both sides of cowl net to facilitate removal.
- 2) Disconnect electric connector, and remove motor attaching bolts.

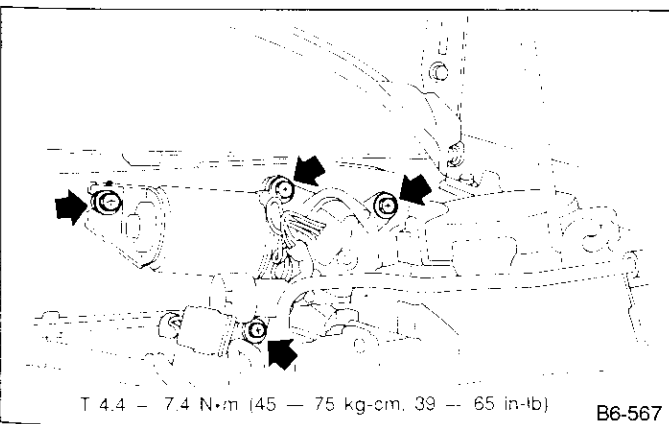


Fig. 62

- 3) Remove nut securing motor link on the back side of motor.

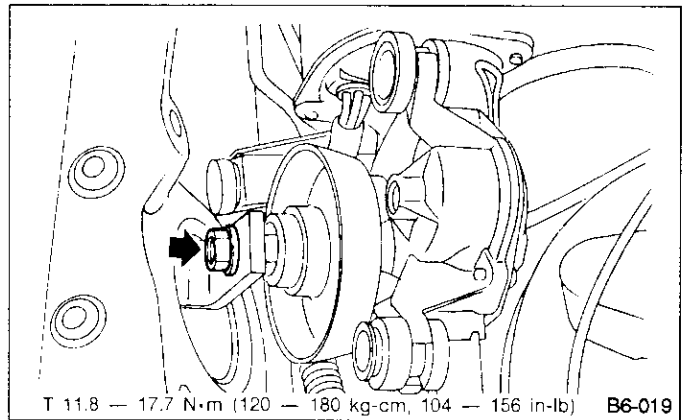


Fig. 63

- 4) Remove nuts which secure left sleeve unit (as viewed from rear of vehicle).

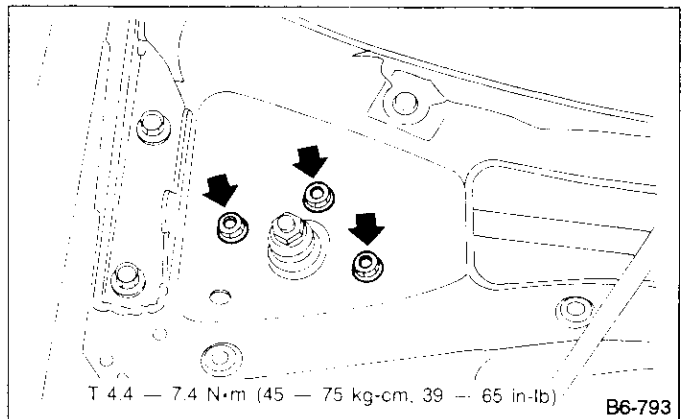


Fig. 64

- 5) Separate left and right wiper links at center joint. Remove nuts which secure right sleeve unit.
 - a. To facilitate removal of wiper link, pry with a standard screwdriver inserted into service hole in front panel.
 - b. To assemble wiper links, push using grip of screwdriver.

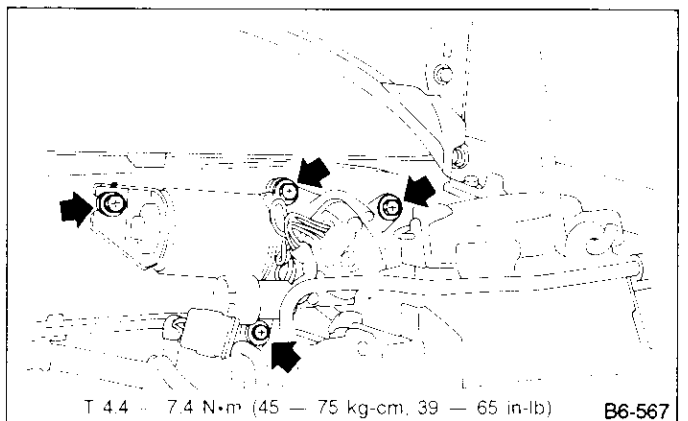


Fig. 65

6) Remove wiper link from service hole in front panel.

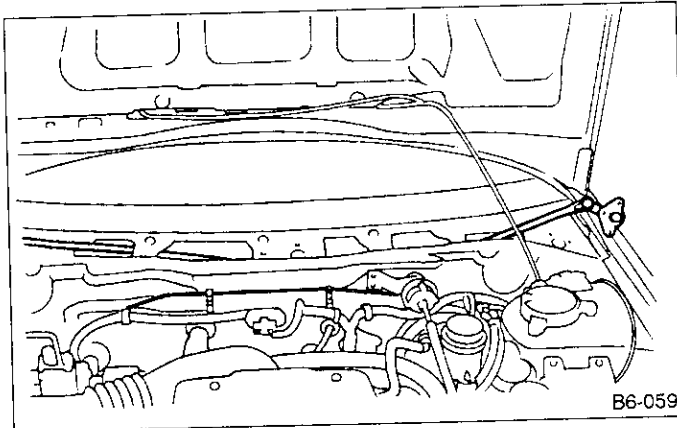


Fig. 66

4. WASHER TANK

- 1) Remove washer tank attaching bolts.
- 2) While removing washer tank, disconnect connector and washer hose.

Before installing washer tank, position locating boss (on lower side of washer tank) in hole on body.

Tightening torque:

4.4 — 7.4 N·m
(45 — 75 kg-cm, 39 — 65 in-lb)

5. NOZZLE

- 1) Disconnect washer hose from nozzle.
- 2) Push nozzle clip in direction A. (See Figure below.)
- 3) Remove nozzle from hood.

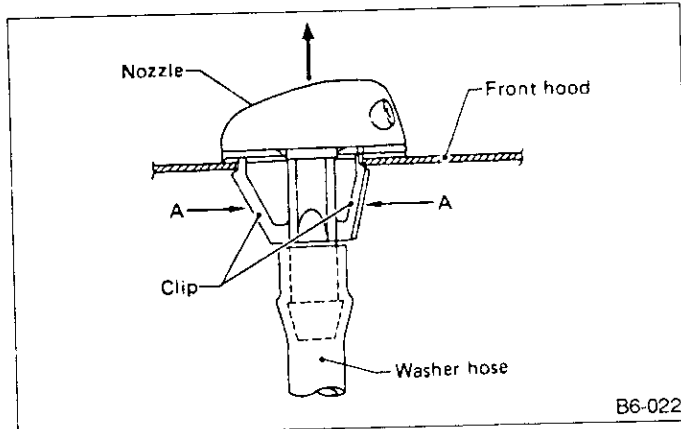


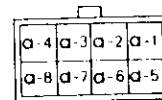
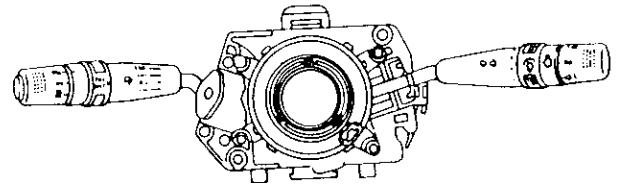
Fig. 67

6. COMBINATION SWITCH

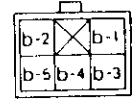
(Ref. to [6-2]).

D: INSPECTION

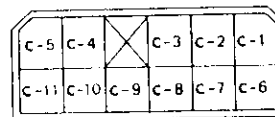
1. FRONT WIPER AND WASHER SWITCH



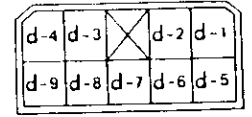
(Black)



(Black)



(Black)



(Black)

B6-525

Fig. 68

Set wiper switch to each position and check continuity between terminals (indicated in table below).

Wiper switch

Terminal (Wire color)		d-9 (Y)	d-8 (L)	d-6 (LY)	d-7 (LW)	INT1	INT2
		Switch position					
OFF	OFF	○—○					
	↓	x—x					
	MIST		○—○				
INT	OFF	○—○				○—○	
	↓	x—x					
	MIST		○—○			○—○	
LO	OFF		○—○				
	↓	x—x					
	MIST		○—○				
HI	OFF			○—○			
	↓	x—x					
	MIST		○—○	○—○			

Washer switch

Terminal (Wire color)	d-5 (B)	d-2 (W)
Switch position		
OFF		
ON		

For on-car check procedures, (Ref. to [6-2] No. W6E1)

2. WIPER MOTOR

1) Check wiper motor operation at low speed.
Connect battery to wiper motor. Check wiper motor for proper operation at low speed.

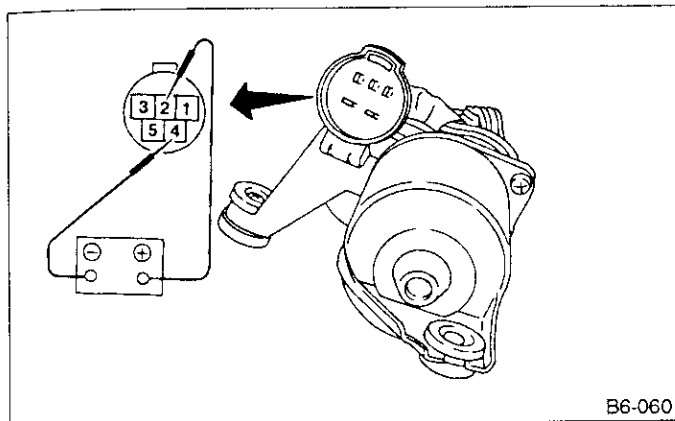


Fig. 69

2) Check wiper motor operation at high speed.
Connect battery wiper motor. Check wiper motor for proper operation at high speed.

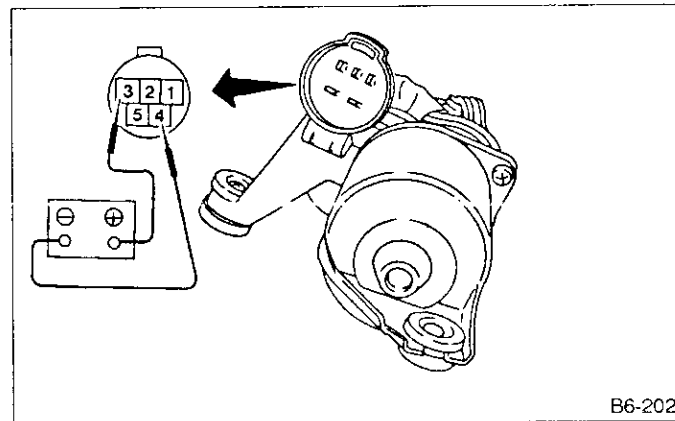


Fig. 70

3) Check wiper motor for proper stoppage.
Connect battery to wiper motor. After operating wiper motor at low speed, disconnect battery to stop it.

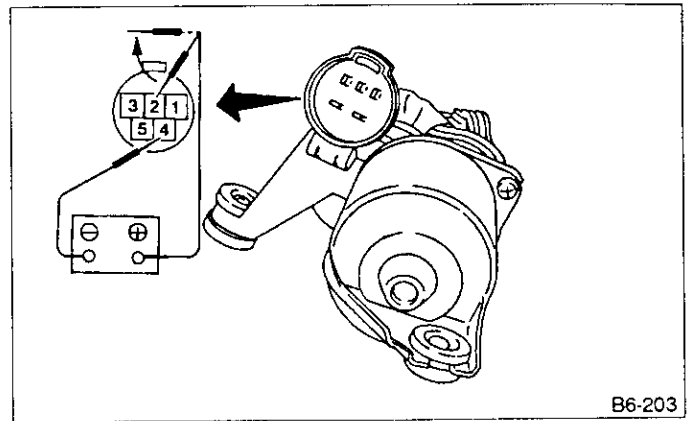


Fig. 71

Reconnect battery and ensure that wiper motor stops at "AUTO STOP" after operating at low speed.

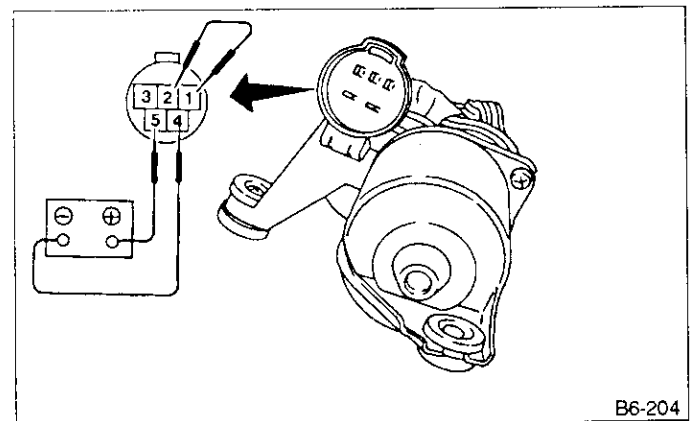


Fig. 72

3. WASHER MOTOR

Connect battery to washer motor and check operation of washer motor.

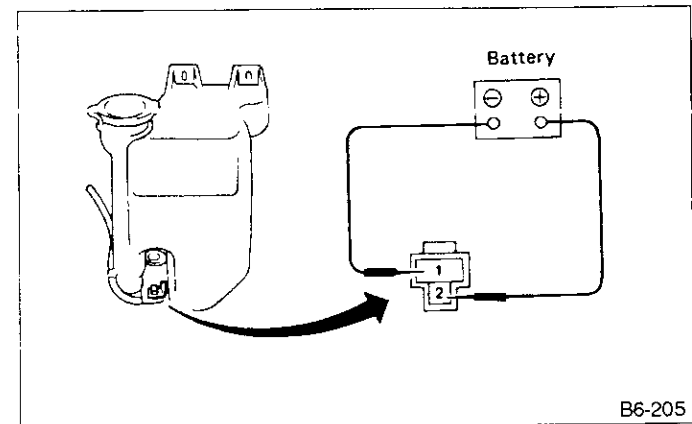
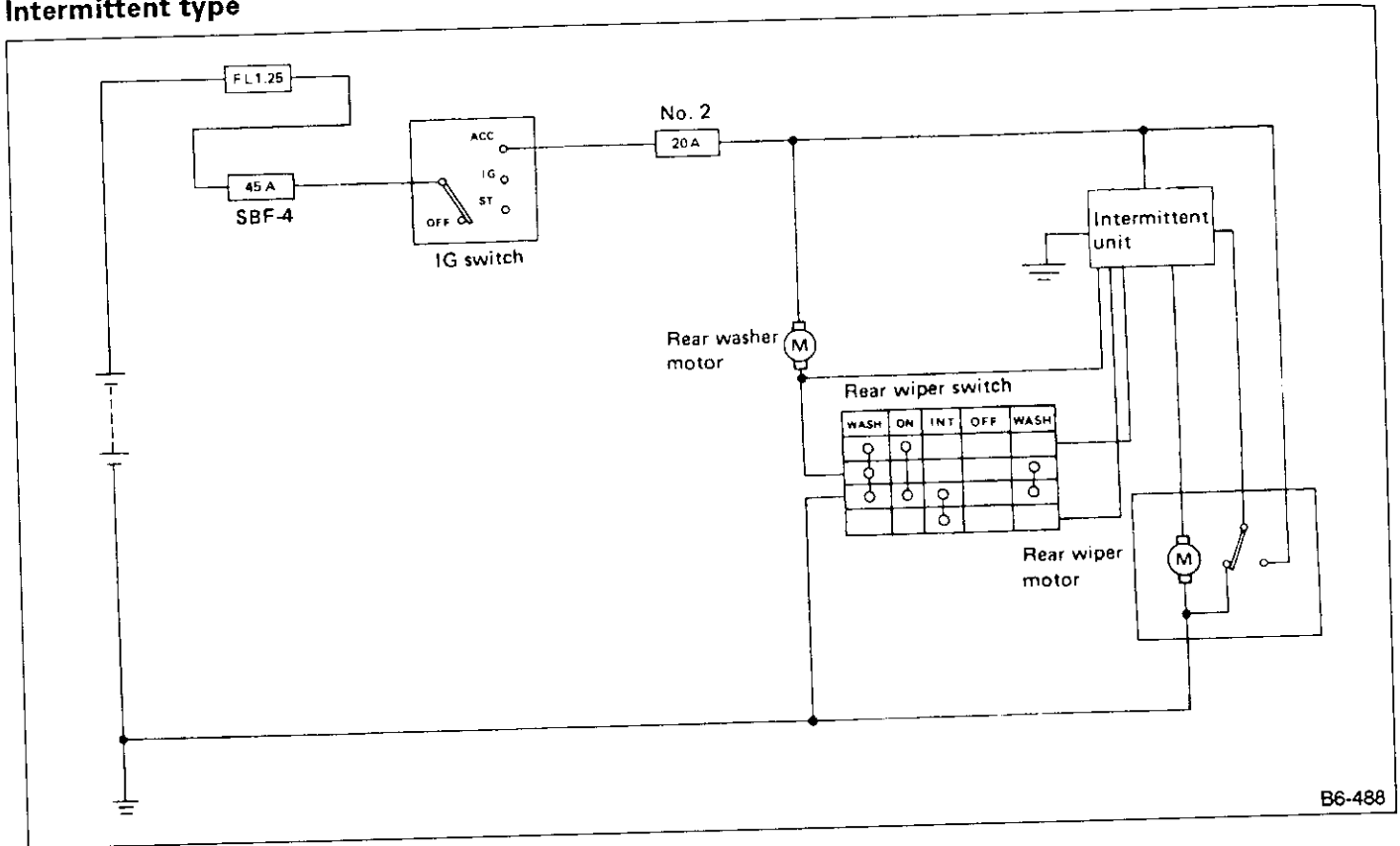


Fig. 73

16. Rear Wiper and Washer

A: SCHEMATIC

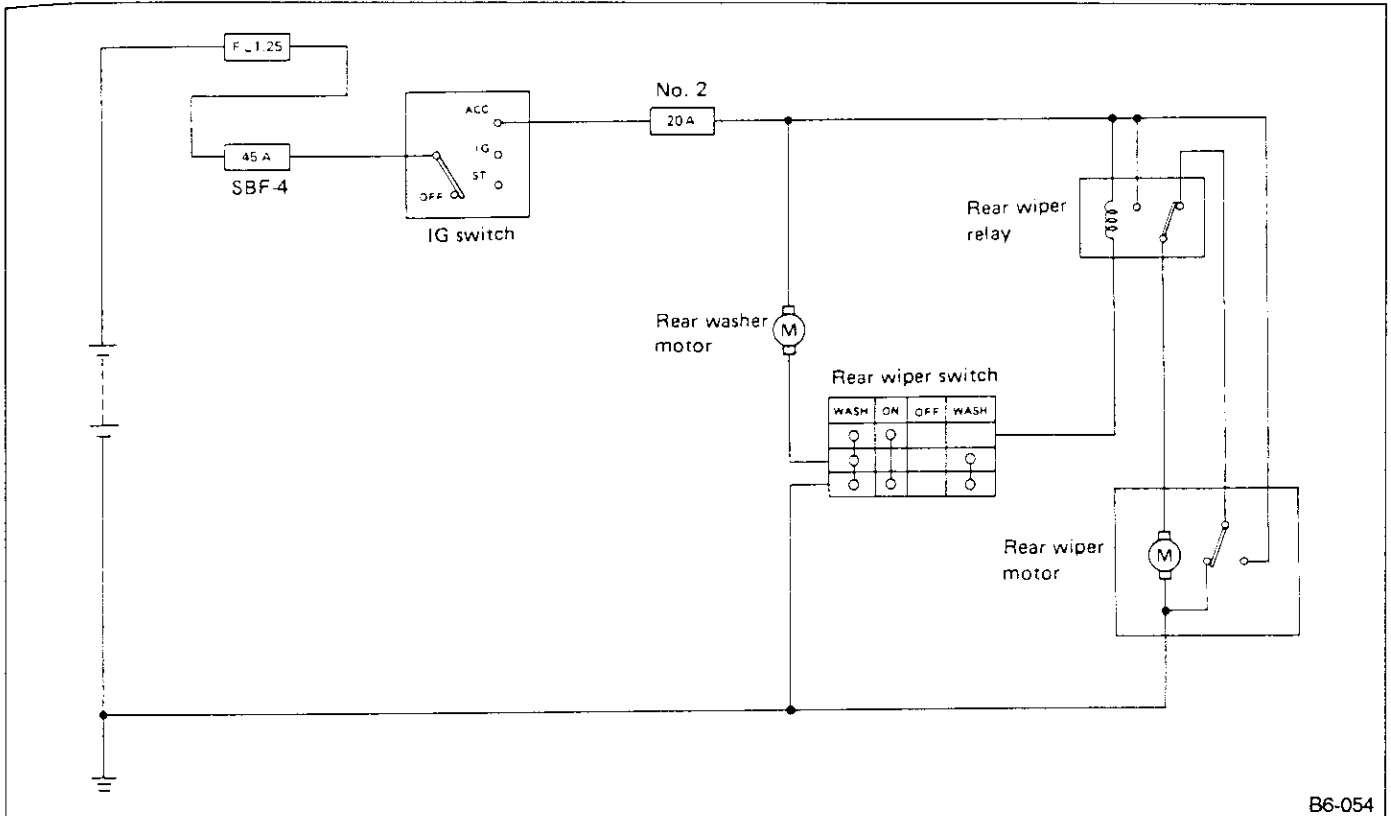
Intermittent type



B6-488

Fig. 74

Others



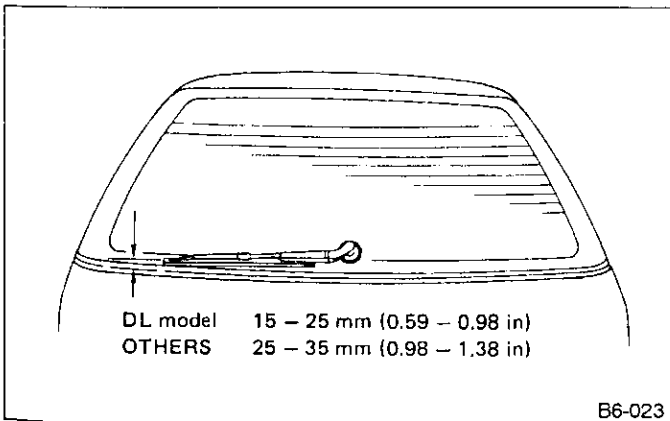
B6-054

Fig. 75

B: ON-CAR SERVICE

1. ADJUSTMENT

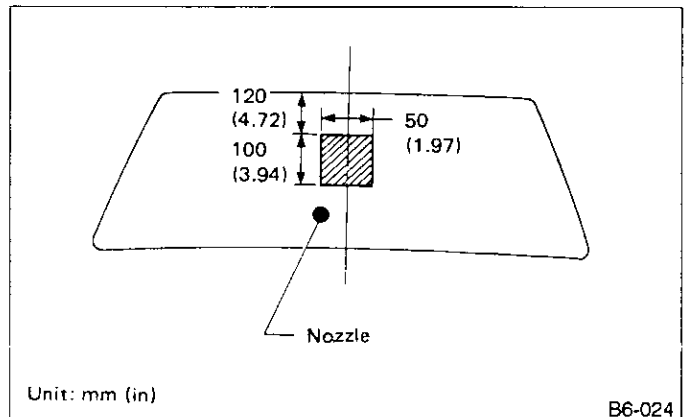
1) Adjust wiper blade in original position as shown in the illustration by changing wiper arm installation.



B6-023

Fig. 76

2) Adjust washer ejecting point on rear gate window as shown in the illustration when the car stops.



B6-024

Fig. 77

C: REMOVAL AND INSTALLATION

1. BLADE

Pull out blade from arm while pushing up clip.

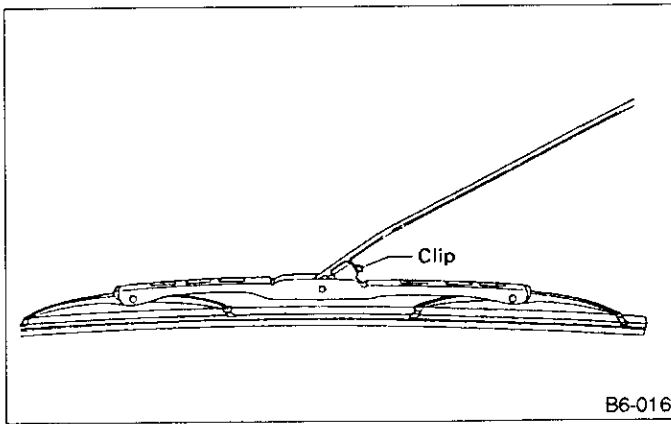


Fig. 78

2. WIPER ARM

- 1) Remove head cover.
- 2) Remove nut and wiper arm.

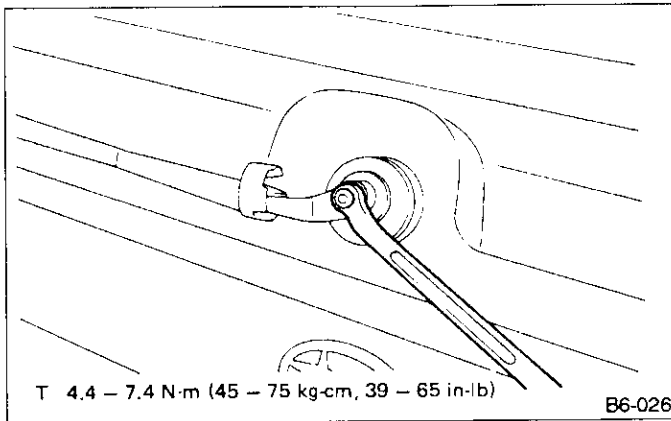


Fig. 79

3. WIPER MOTOR

- 1) Remove cap and special nut.

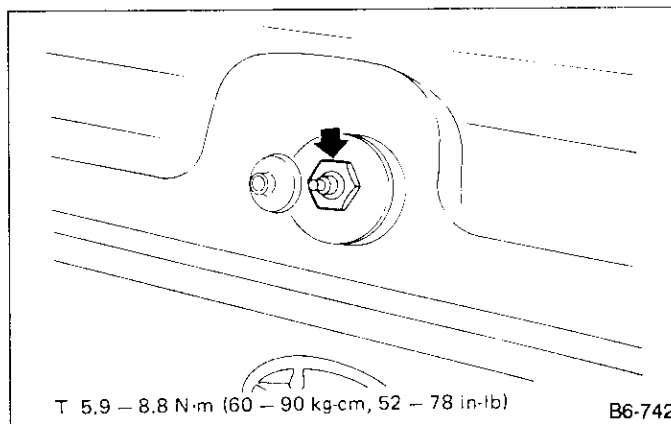


Fig. 80

Be careful not to strike service tool against nozzle during removal.

- 2) Remove rear gate trim. (Ref. to [5-2].)
- 3) Undo clips which secure harness, and disconnect harness connector.

Two types of clips are used. Do not confuse one type with the other during installation.

- 4) Separate washer hoses at joint.
- 5) Remove attaching screws and take out wiper motor ASSY.

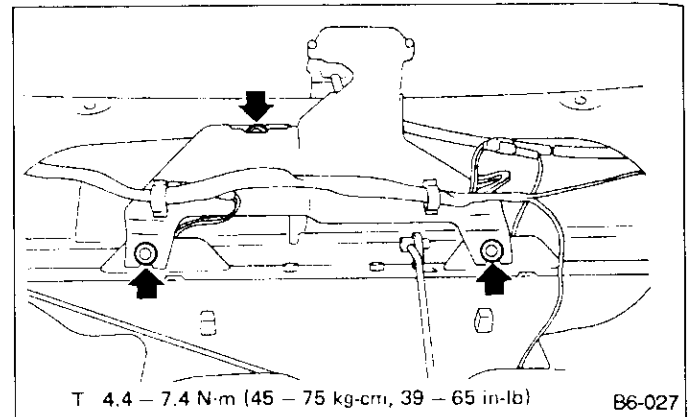


Fig. 81

Be careful not to damage O-ring when removing wiper motor ASSY.

4. WASHER TANK

- 1) Open cover. Remove screws, clips and retainers from rear quarter trim panel. Also remove screws and clips from left of rear edge.

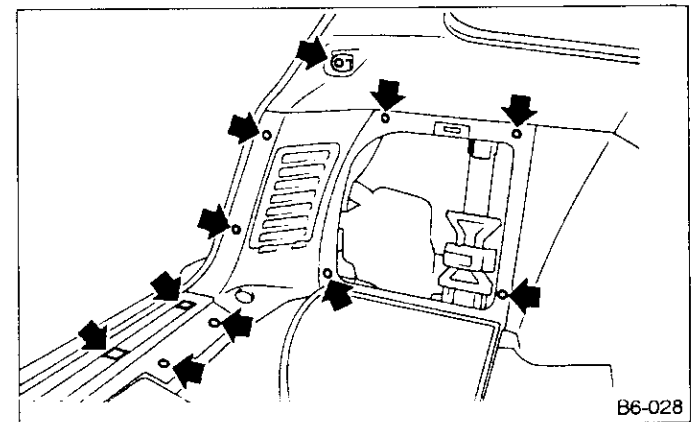


Fig. 82

- 2) Disconnect washer hose.
- 3) While pulling rear quarter trim panel, remove attaching bolts.

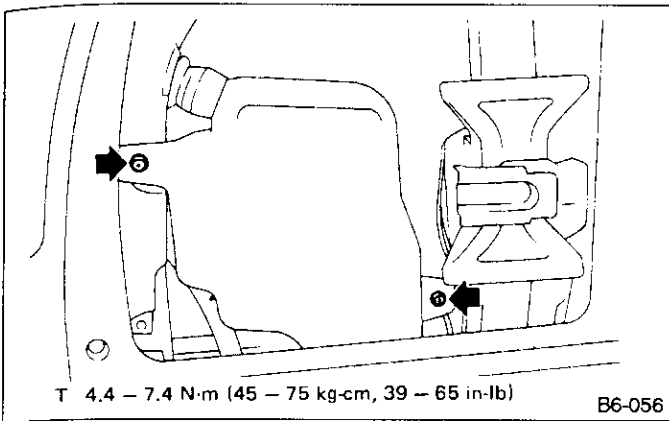


Fig. 83

4) While removing washer tank, disconnect connector and hose (from joint).

D: INSPECTION

1. REAR WIPER AND WASHER SWITCH

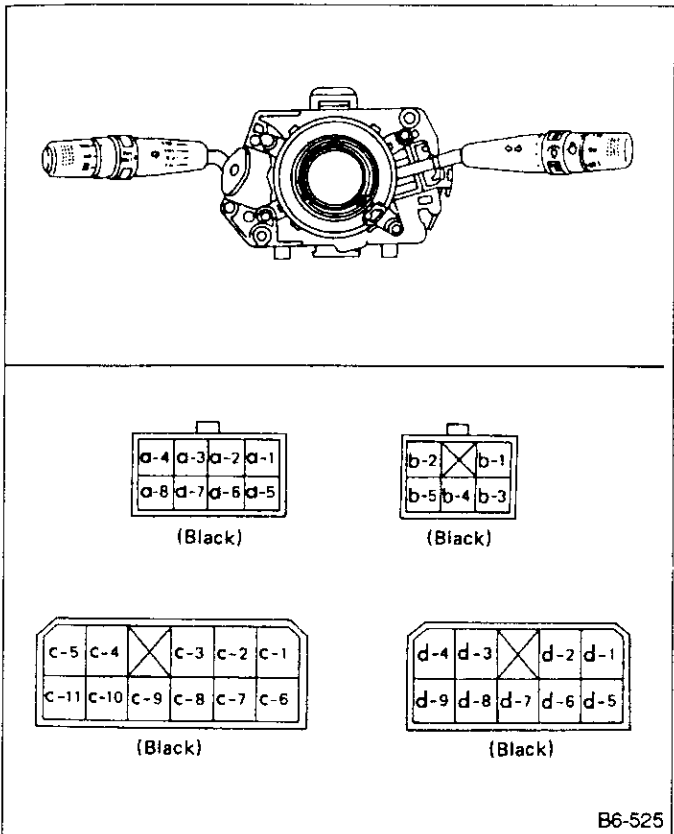


Fig. 84

Set rear wiper and washer switch to each position and check continuity between terminals (indicated in table below).

Terminal	d-2	d-1	d-4	d-3
Switch position				
WASH	○—○			
OFF				
INT	○—○		○—○	
ON	○—○			○—○
WASH	○—○	○—○		○—○

For "on-car" inspection procedures; (Ref. to [6-2] No. W6E1.)

2. WIPER MOTOR

1) Operational check

Connect battery to wiper motor and check operation of wiper motor.

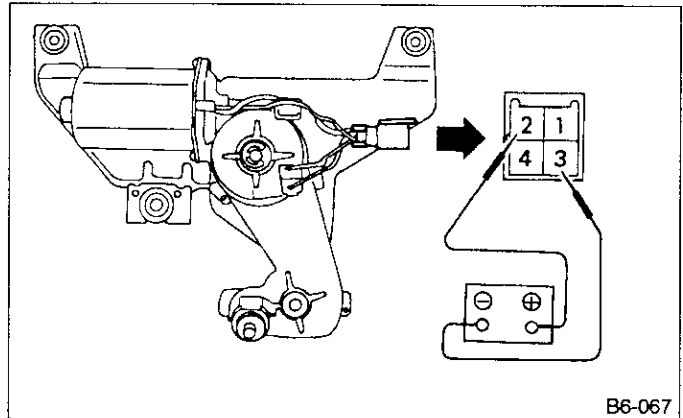


Fig. 85

2) Check wiper motor for proper stoppage.

After operating wiper motor, disconnect battery from wiper motor.

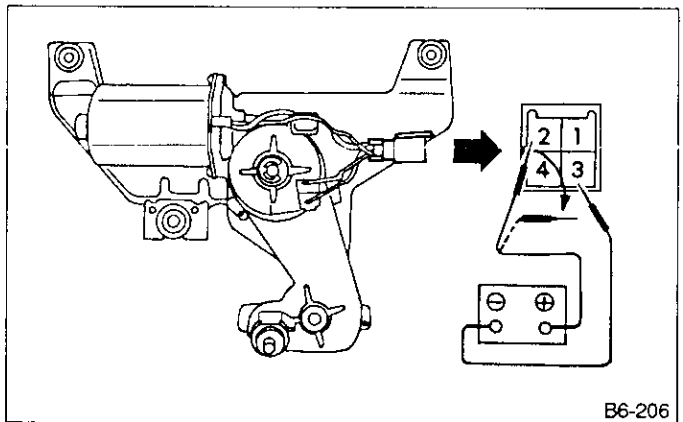
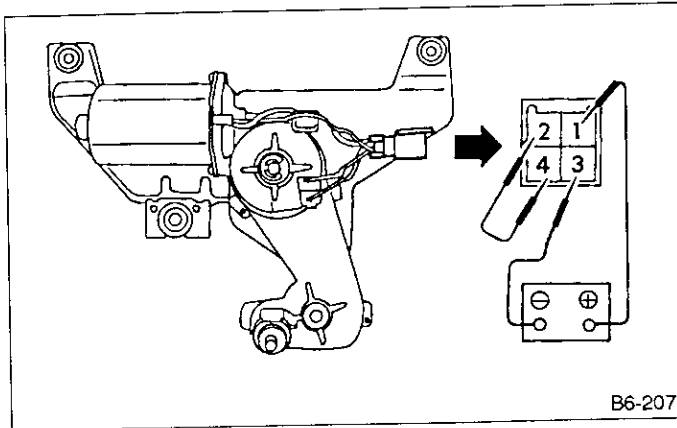


Fig. 86

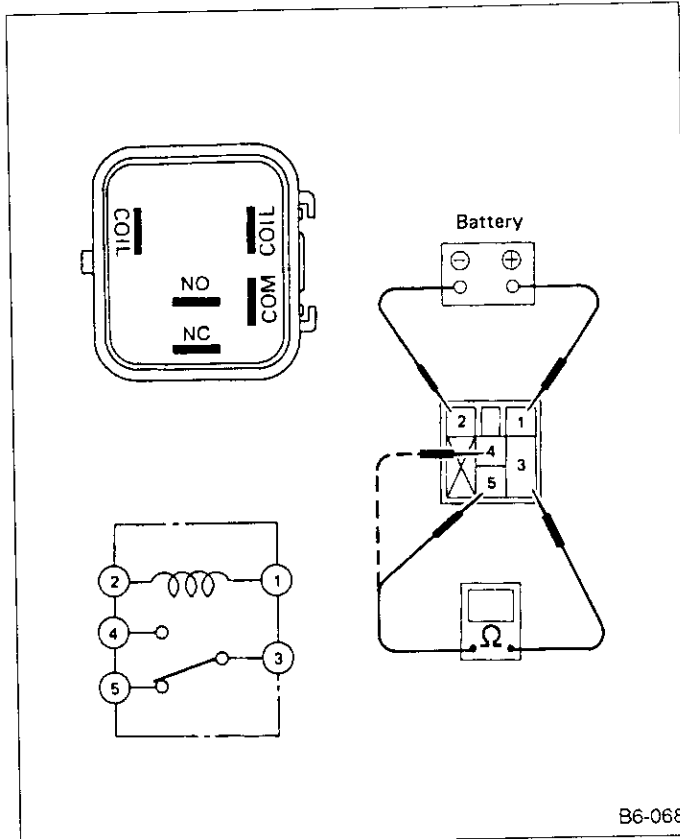
Reconnect battery and ensure that wiper motor stops at "AUTO STOP" after it has been operated.



B6-207

Fig. 87

3. REAR WIPER RELAY



B6-068

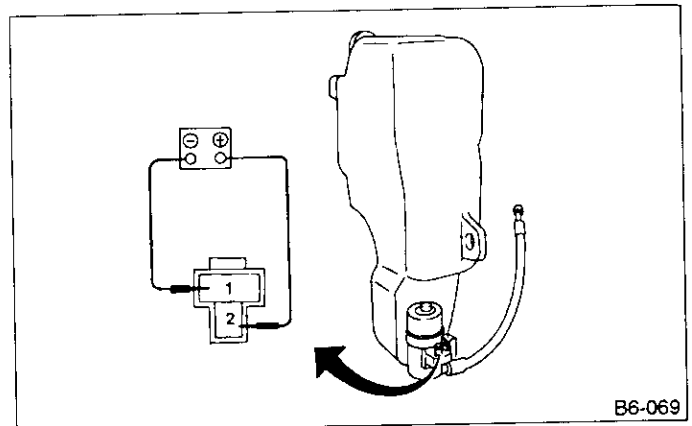
Fig. 88

Connect battery to terminal (1) and ground terminal (2). Check continuity between terminals (indicated in table below).

When current flows	Between terminals (3) and (5)	Continuity does not exist.
	Between terminals (3) and (4)	Continuity exists.
When current does not flow	Between terminals (3) and (5)	Continuity exists.
	Between terminals (3) and (4) Between terminals (1) and (2)	Continuity does not exist. Continuity exists.

4. WASHER MOTOR

Connect battery to washer motor and check operation of washer motor.

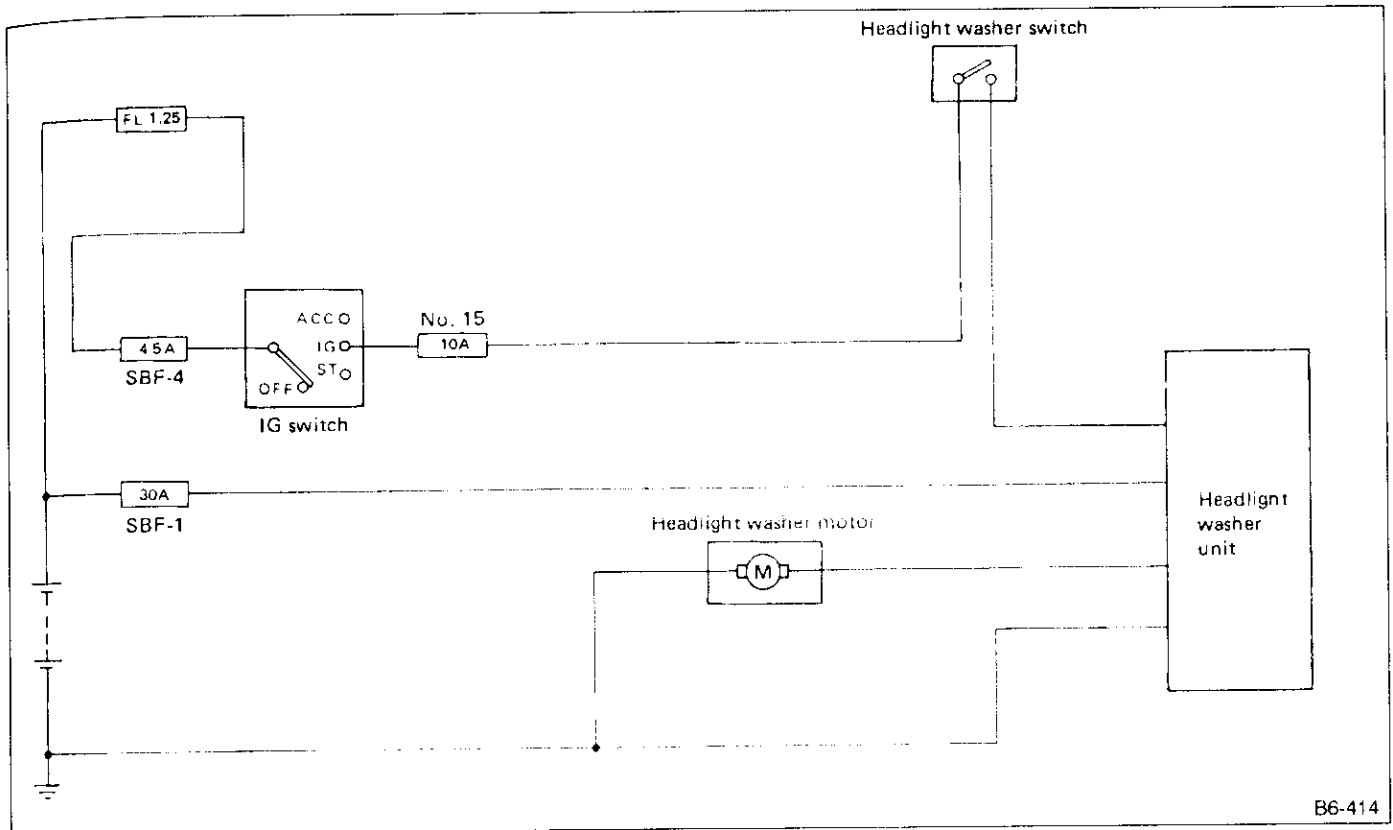


B6-069

Fig. 89

17. Headlight Washer

A: SCHEMATIC



B6-414

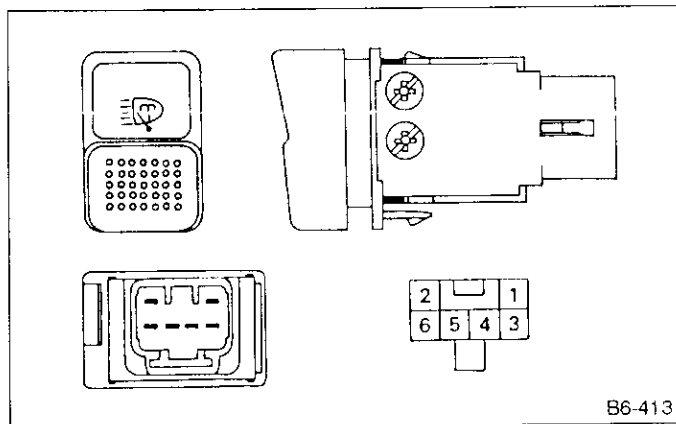
Fig. 90

B: INSPECTION

Set switch to each position and check continuity between terminals (indicated in the table below).

1. HEADLIGHT WASHER SWITCH

	3	5		4	2
ON	○	○		○	○
OFF				○	○

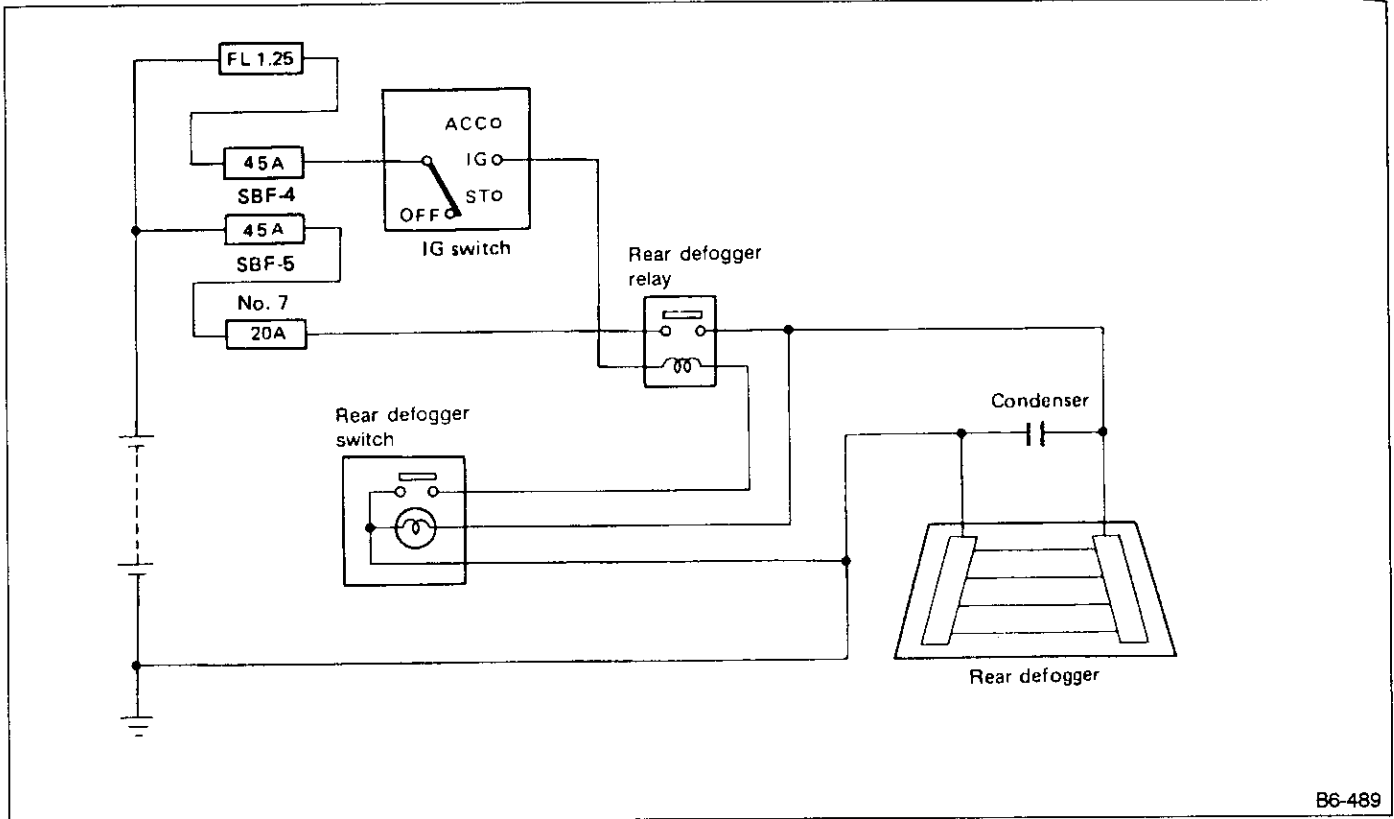


B6-413

Fig. 91

18. Rear Window Defogger

A: SCHEMATIC



B6-489

Fig. 92

B: REMOVAL AND INSTALLATION

1. DEFOGGER SWITCH

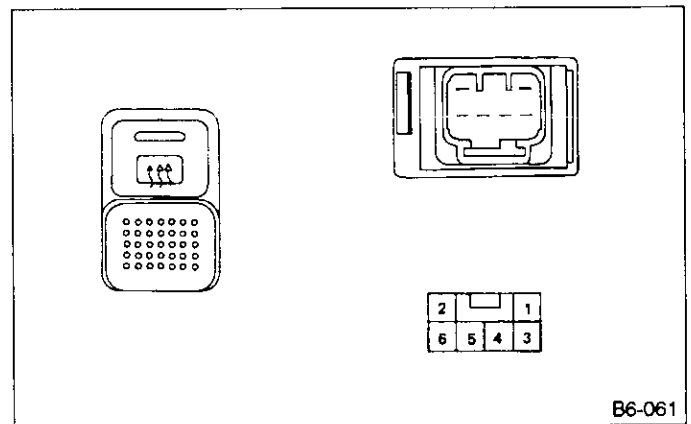
1) Using a small standard screwdriver, remove defogger switch from instrument panel.

Be careful not to damage switch during removal.

2) Disconnect connector.

C: INSPECTION

1. DEFOGGER SWITCH



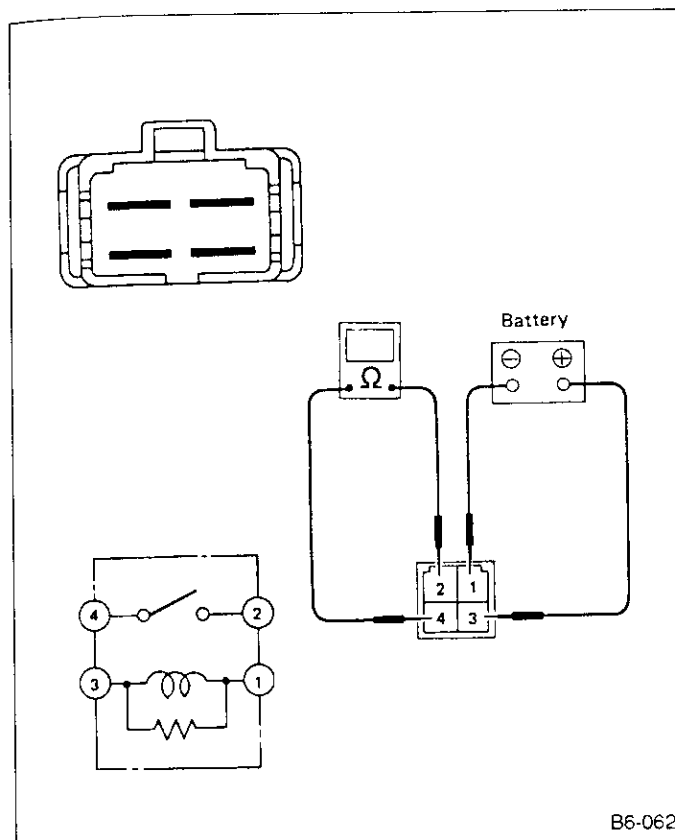
B6-061

Fig. 93

Set switch to each position and check continuity between terminals (indicated in table below).

Terminal	3	5		1	4		2
Switch position							
OFF					○	○	○
ON	○	○	○	○	○	○	○

2. DEFOGGER RELAY



B6-062

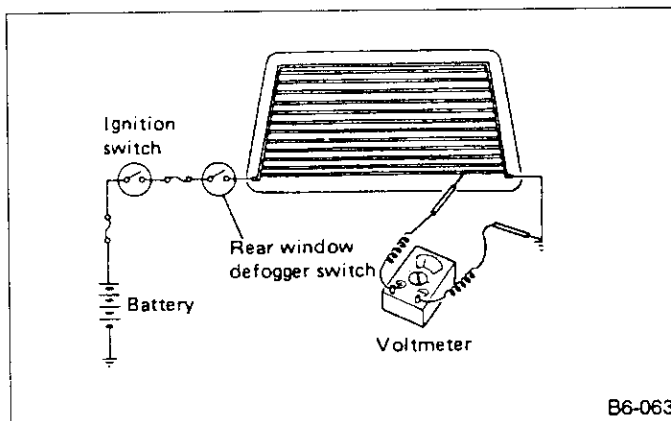
Fig. 94

Connect battery to terminal (3) and ground terminal (1). Check continuity between terminals (indicated in table below).

When current flows	Between terminals (2) and (4)	Continuity exists.
When current does not flow	Between terminals (2) and (4)	Continuity does not exist.
	Between terminals (1) and (3)	Continuity exists.

3. HEAT WIRES

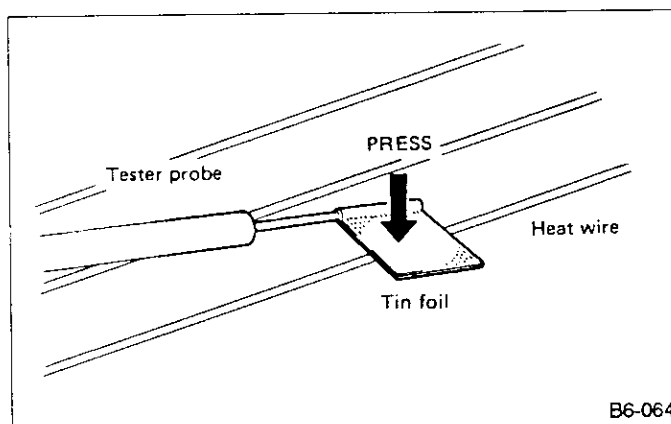
- 1) Start the engine so that battery is being charged.
- 2) Turn defogger switch ON.
- 3) Check each heat wire at its center position for discontinuity by setting direct-current voltmeter. Normal indication is about 6 volts.



B6-063

Fig. 95

When measuring voltage, wind a piece of tin foil around the tip of the negative probe and press the foil against the wire with your finger.



B6-064

Fig. 96

4) When tester indicates 12 volts when its probe reaches point "A", a broken circuit occurs between point "A" and the negative terminal. Slowly move tester probe toward the negative terminal while contacting it on heat wire to locate point where tester indication changes abruptly (0 volts). This is the point where a broken circuit occurs.

When tester indicates 0 volts when its probe reaches point "A", a broken circuit occurs between point "A" and the positive terminal. Locate a point where tester indication changes abruptly (12 volts) while slowly moving tester probe toward the positive terminal.

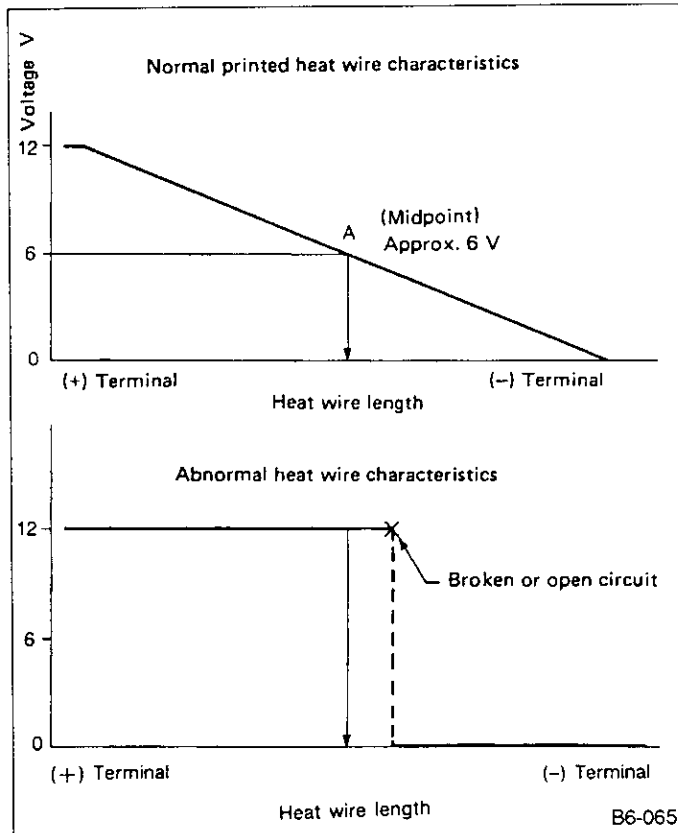


Fig. 97

D: REPAIR

- 1) Clean broken wire and its surrounding area.
- 2) Cut off slit on (used) thin film by 0.5 mm (0.020 in) width and 10 mm (0.39 in) length.
- 3) Place the slit on glass along the broken wire, and deposit conductive silver composition (DUPONT No. 4817) on the broken portion.

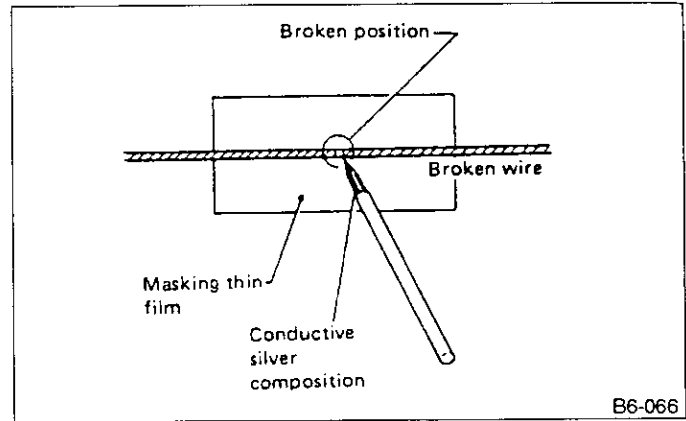
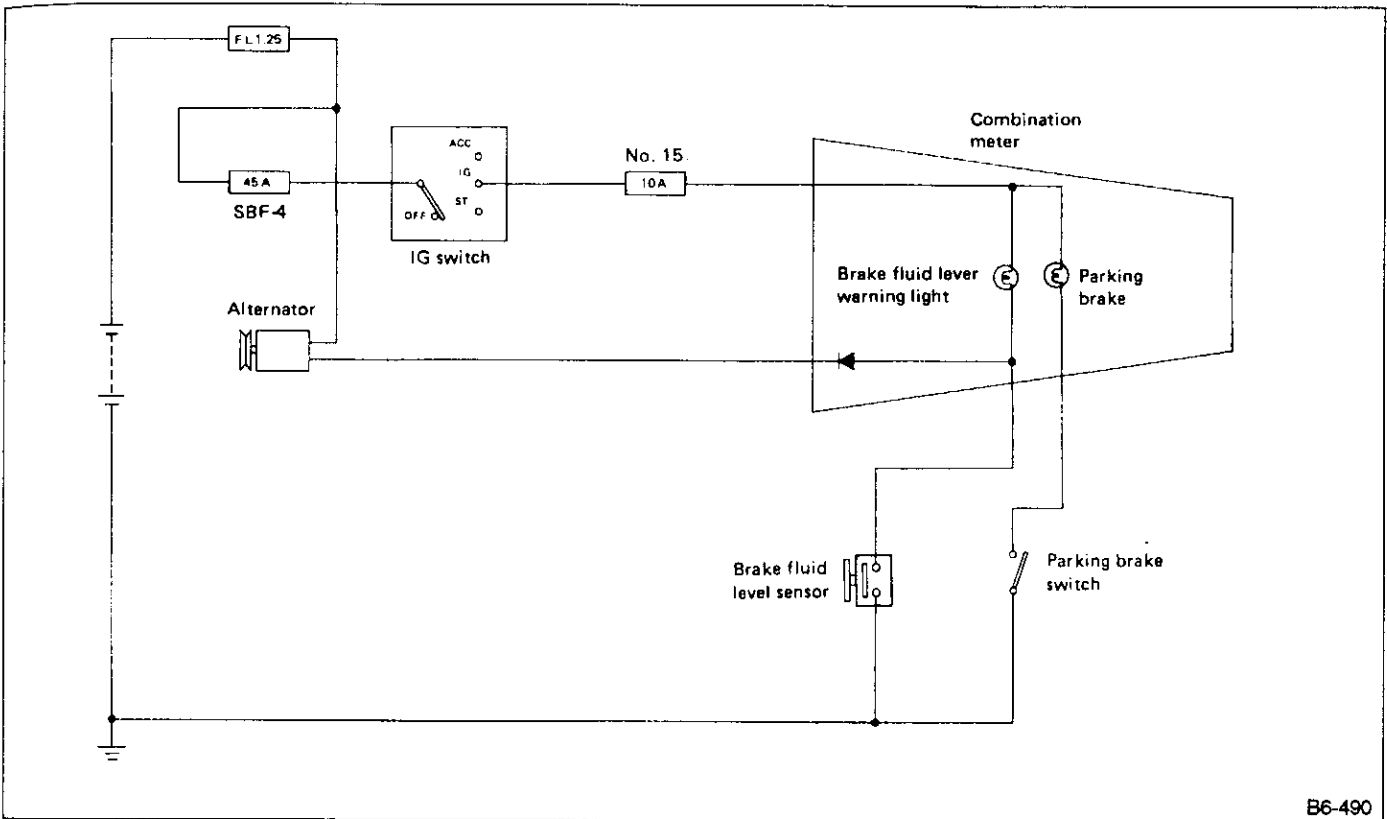


Fig. 98

- 4) Dry out the deposited portion.
- 5) Inspect the repaired wire for continuity.

19. Parking Brake Switch and Brake Fluid Level Warning

A: SCHEMATIC



B6-490

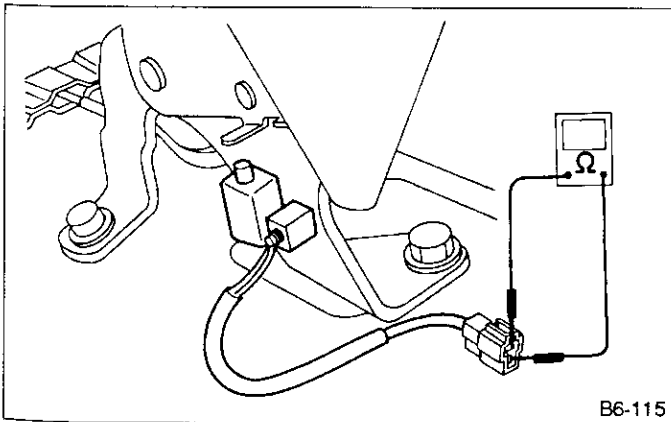
Fig. 99

B: INSPECTION

1. PARKING BRAKE SWITCH

- 1) Remove right-hand front seat.
- 2) Remove console box and parking brake cover. (Ref. to [5-3].)
- 3) Roll up floor mat and disconnect switch connector.

Ensure that parking brake switch activates at one notch stroke intervals of lever engagement.



B6-115

Fig. 100

Terminal	1	2
Switch position		
Lever pulled	○	○
Lever returned		

20. Fuel Gauge

A: SCHEMATIC

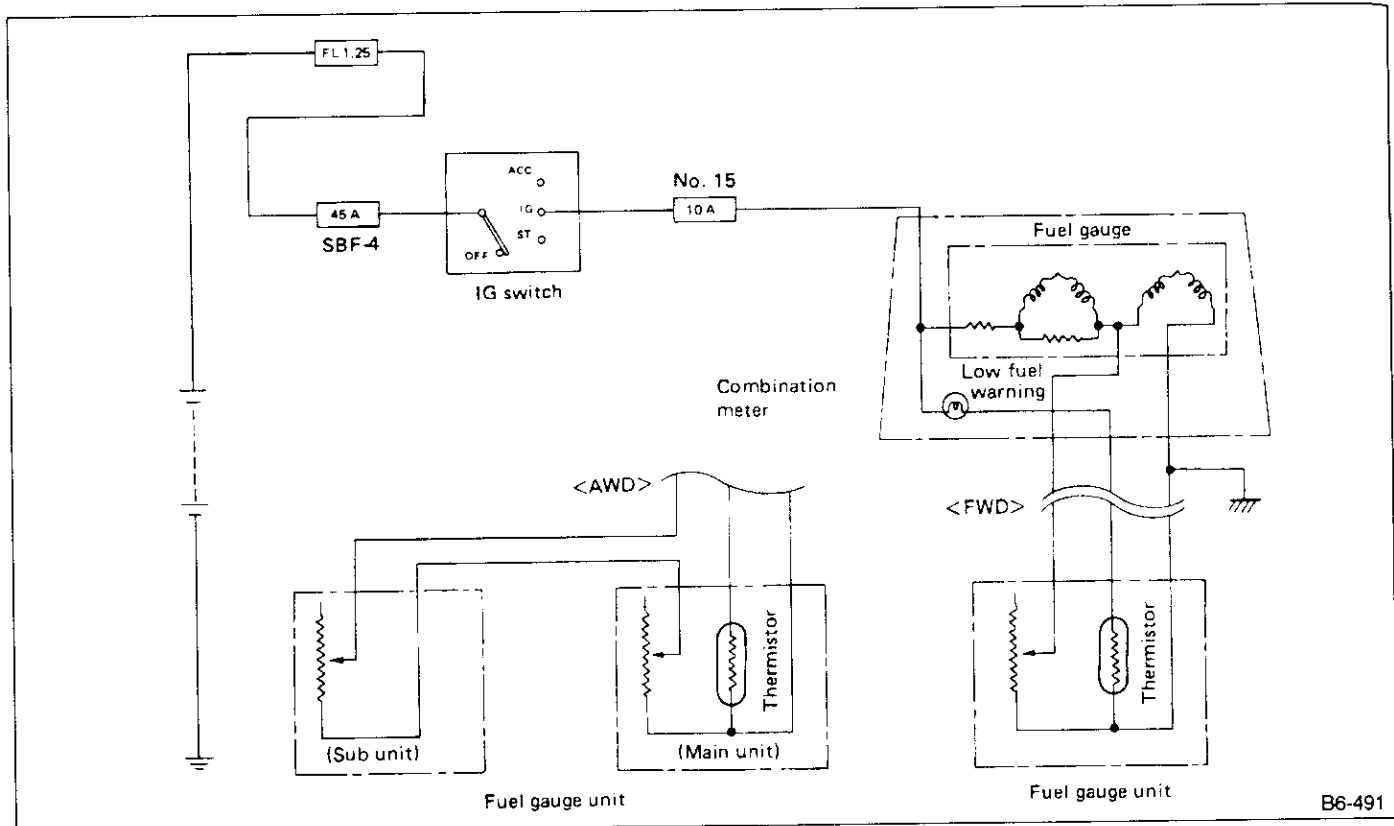


Fig. 101

B: REMOVAL AND INSTALLATION

1. FUEL GAUGE UNIT

<Ref. to [2-8].>

C: INSPECTION

1. FUEL GAUGE UNIT

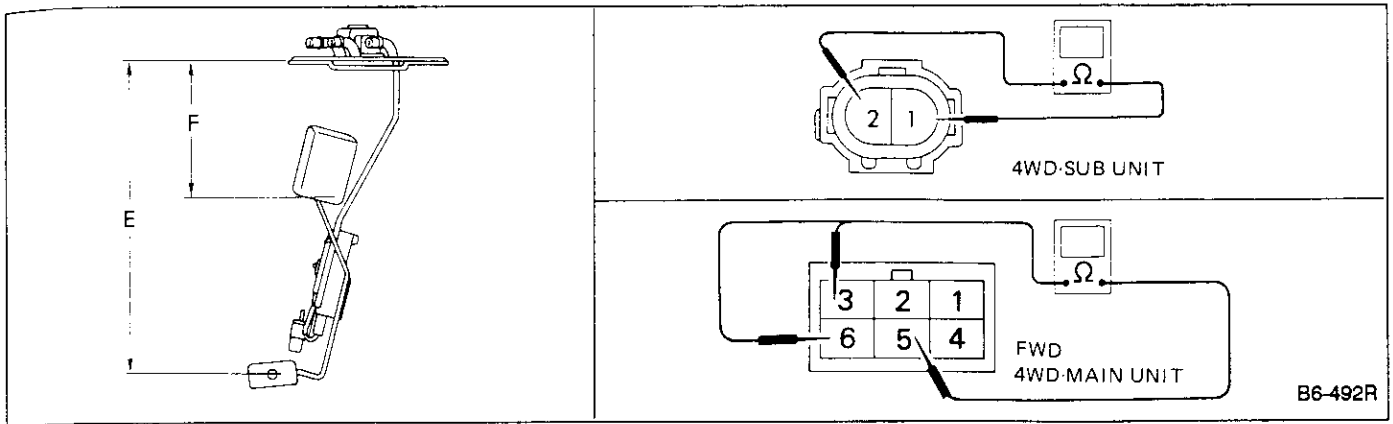
1) Float position

While moving float, determine point F (upper limit position) where float arm contacts stopper and point E (lower limit position).

2) Standard resistance of fuel gauge unit

When float is at point F (upper limit position) and point E (lower limit position), measure resistance between terminals (1) and (2) (4WD-sub unit) [or between terminals (3) and (5) (4WD model), terminals (5) and (6) (FWD model)].

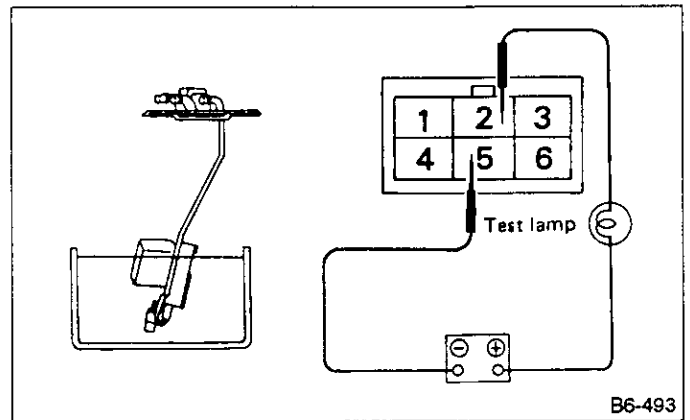
Float position and resistance		Vehicle type	FWD	4WD	
				MAIN UNIT	SUB UNIT
Float position	mm (in)	F	94 ± 3 (3.70 ± 0.12)	80.9 ± 3 (3.185 ± 0.118)	72.9 ± 3 (2.870 ± 0.118)
		E	230.4 ± 3 (9.07 ± 0.12)	252.0 ± 3 (9.92 ± 0.12)	249.0 ± 3 (9.80 ± 0.12)
Normal resistance	(Ω)	F	2.0 — 5.0	0.5 — 2.5	0.5 — 2.5
		E	92.0 — 95.0	50.0 — 52.0	42.0 — 44.0



B6-492R

Fig. 102

- 3) Ensure that resistance gradually changes when float is slowly moved from point F to point E, and vice versa.
- 4) Low fuel warning sensor (thermistor)
Connect fuel gauge unit and test lamp (12V-3.0W) to battery, and connect terminal (5) to fuel gauge unit and terminal (2) to test lamp, respectively.
Ensure that test lamp remains off when fuel gauge unit is dipped in fuel and comes on when removed from fuel.



B6-493

Fig. 103

21. Combination Meter

A: DESCRIPTION

1. WARNING AND INDICATOR LIGHT

According to ignition switch position, each light will come on and/or go off under normal conditions as follows:

Ignition switch position	OFF	ACC	ON	ST	While engine is running
AT oil temperature warning light	OFF	OFF	ON	ON	OFF
Charge indicator light	OFF	OFF	ON	ON	OFF
Oil pressure indicator light	OFF	OFF	ON	ON	OFF
Brake fluid level warning light	OFF	OFF	ON	ON	OFF
Parking brake warning light	OFF	OFF	○	○	○
CHECK ENGINE warning light	OFF	OFF	●	●	OFF
ANTILOCK BRAKE warning light	OFF	OFF	ON	ON	OFF

Symbols used: ○ : Light comes on when parking brake is set.
● : Light comes on before engine starts, and stays off after engine stops.

1) AT oil temperature warning light

This light comes on when ATF reaches at least 150°C (302°F).

2) Charge indicator light

This light comes on when problem occurs in charging system during operation.

3) Oil pressure indicator light

This light comes on when oil pressure drops below 14.7 kPa (0.15 kg/cm², 2.1 psi).

4) Brake fluid level warning light

This light comes on when brake fluid drops below specified level.

5) CHECK ENGINE warning light

This light comes on when problem occurs in MPFI system.

6) ANTILOCK BRAKE warning light

This light comes on when problem occurs in ABS system.

2. TELLTALE (GRAPHIC MONITOR)

According to ignition switch position, each light will come on and/or go off under normal conditions as follows:

Ignition switch position		OFF	ACC	ON	ST	While engine is running
Headlight beam indicator light	High-beam	OFF	OFF	ON	ON	ON
	Low-beam	OFF	OFF	OFF	OFF	OFF
Low fuel warning light		OFF	OFF	●	●	●
Door open warning light	Open	ON	ON	ON	ON	ON
	Shut	OFF	OFF	OFF	OFF	OFF
Rear gate open warning light	Open	ON	ON	ON	ON	ON
	Shut	OFF	OFF	OFF	OFF	OFF
Four wheel drive indicator light (4WD and LO)	Engaged	OFF	OFF	ON	ON	ON
	Disengaged	OFF	OFF	OFF	OFF	OFF
AT selector position indicator light		OFF	OFF	ON	ON	ON
Power indicator light		OFF	OFF	OFF	OFF	△
Manual indicator light		OFF	OFF	□	□	□
Front wheel drive indicator light	FWD	OFF	OFF	ON	ON	ON
	4WD	OFF	OFF	OFF	OFF	OFF

Symbols used: □: Light comes on when manual switch is pressed.
 ●: Light comes on when fuel in fuel tank drops below specified level (close to "empty").

- 1) Headlight beam indicator light
This light comes on when headlights are set to "high" beam.
- 2) Low fuel warning light
This light comes on when fuel in fuel tank is less than 9 liters (9.5 US qt, 7.9 Imp qt).
- 3) Door/rear gate open warning light

- This light comes on when door or rear gate is not completely closed.
- 4) Front wheel drive indicator light
This light comes on when "full-time" 4WD mode is arbitrarily set to FWD mode (that is, a fuse is inserted into FWD switch).

B: REMOVAL AND INSTALLATION**1. COMBINATION METER**

- 1) Loosen bolts which secure steering column and suspend steering column. (Ref. to [4-3].)
- 2) Remove ventilation grille from visor. Remove various switches using a small standard screwdriver. Also disconnect switch connectors.

Be careful not to damage visor and switches during removal.

- 3) Remove cup holder.
- 4) Remove screws which secure visor, and remove visor.

Also disconnect hazard switch connector.

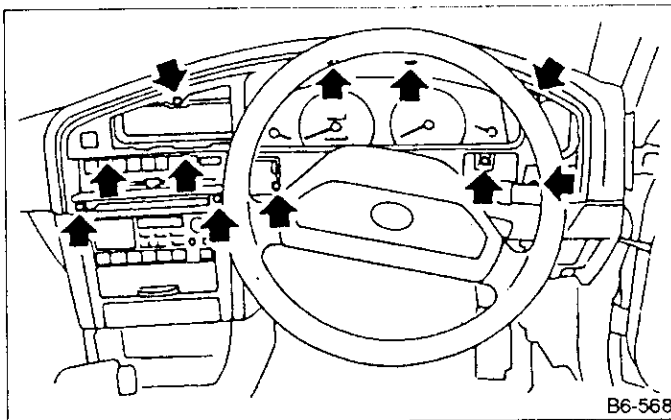


Fig. 104

- 5) Remove screws which secure combination meter, and pull combination meter out.

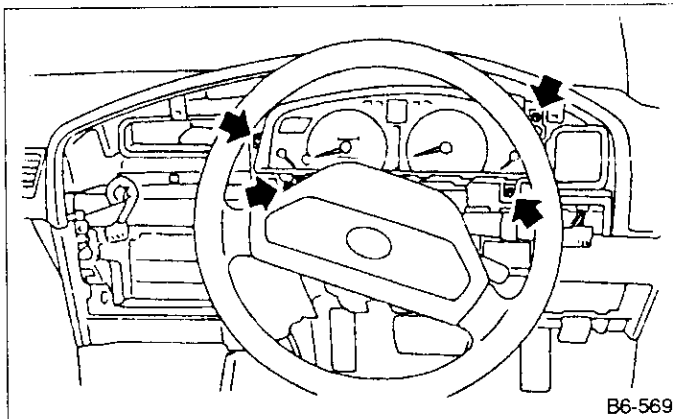


Fig. 105

- 6) Disconnect connector and speedometer cable from back of combination meter.

Connect connector and speedometer cable in that order during installation.

- 7) While tilting combination meter to the side, remove it from instrument panel.

Be sure to connect speedometer cable and connectors to backside of combination meter.

C: DISASSEMBLY AND ASSEMBLY**1. METER ASSY**

- 1) Remove following parts from combination meter:

- Trip meter reset knob
- Meter glass
- Window plate

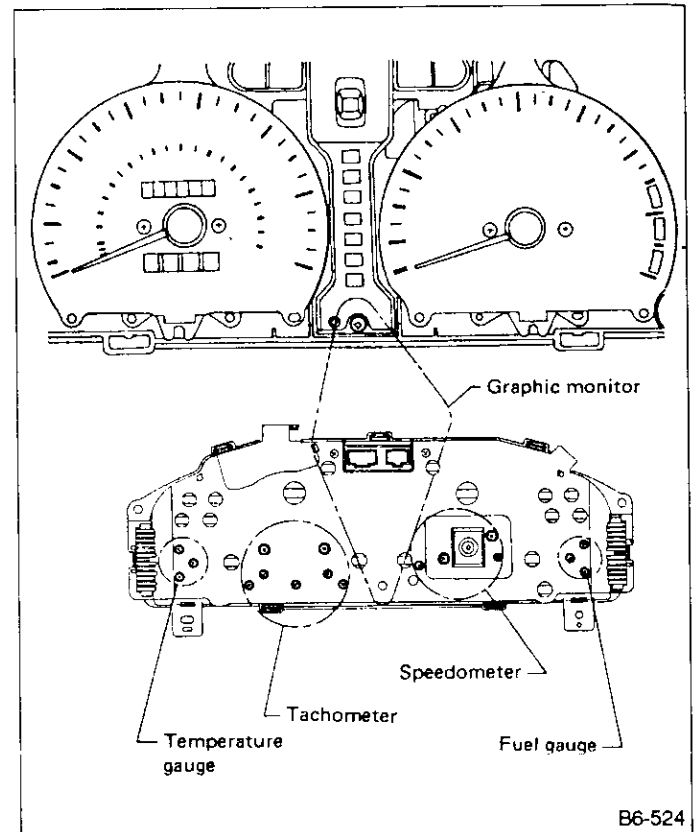


Fig. 106

- 2) Remove screws, and take out meter, gauge, etc.
 - a. Take care not to damage removed speedometer, tachometer etc.
 - b. Remove temperature gauge, fuel gauge and plate as a unit.
- 3) Take out printed circuit board.
- 4) Assembly is in the reverse order of disassembly.

2. BULB REPLACEMENT

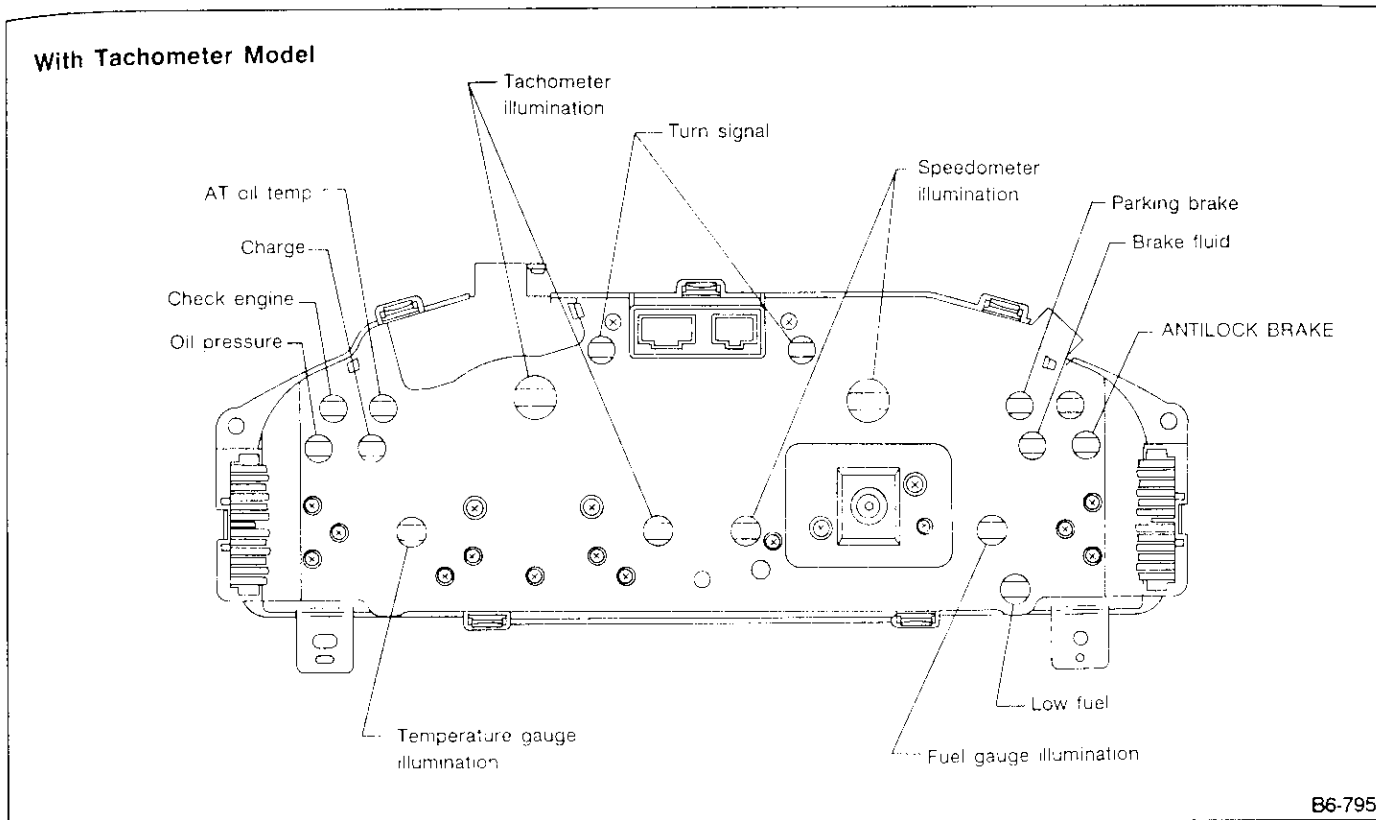


Fig. 107

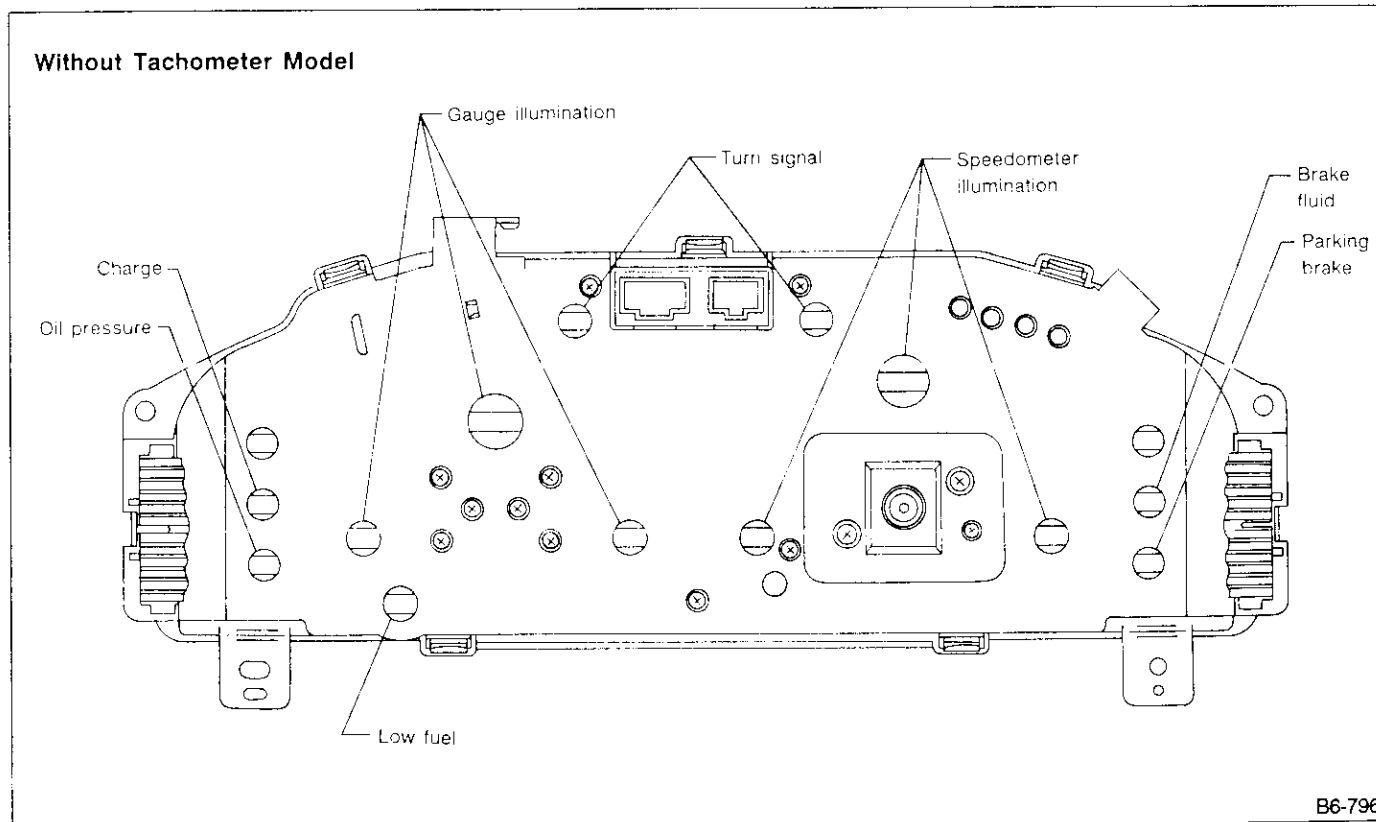


Fig. 108

D: INSPECTION

1. SPEEDOMETER

It is normal if the readings of speedometer are within the tolerances shown in the table 1, against the standard indicated speeds on the speedometer tester. Besides, speedometer should point as shown in the table 2.

Table 1

1) Without tachometer model

Standard indicated speed (km/h or MPH)		20	40	60	80	100
Readings of speedometer	(km/h)	+ 4.7 + 1.0	+ 4.5 + 1.5	+ 5.2 + 1.5	+ 6.1 + 1.5	+ 6.9 + 1.5
	(MPH)	+ 2.9 + 0.6	+ 2.8 + 0.9	+ 3.2 + 0.9	+ 3.8 + 0.9	+ 4.3 + 0.9

2) With tachometer model

Standard indicated speed (km/h or MPH)		20	40	60	80	100
Readings of speedometer	Australia (km/h)	+ 2.0 - 3.1	+ 1.5 - 2.0	+ 3.0 - 1.5	+ 4.0 - 1.0	+ 5.5 - 0.5
	TURBO (km/h)	+ 5.6 + 0.9	+ 5.5 + 1.4	+ 6.1 + 1.4	+ 6.7 + 1.4	+ 7.2 + 1.4
	TURBO (MPH)	+ 3.5 + 0.8	+ 3.9 + 0.9	+ 4.5 + 0.9	+ 5.0 + 0.9	+ 5.6 + 0.9
	Others (km/h)	+ 4.0 0	+ 4.5 + 0.5	+ 5.5 + 1.0	+ 6.0 + 1.0	+ 6.5 + 1.5

Table 2

Speedometer should point	Meter drive shaft speed
60 km/h	637 rpm
60 MPH	1,020 rpm

2. TEMPERATURE GAUGE

Temperature gauge (middle-stable bobbin type) is operated by thermistor incorporated in temperature sending unit installed in water pipe. Since thermistor resistance changes with voltage, voltage regulator is provided to prevent error in gauge indication due to voltage fluctuation.

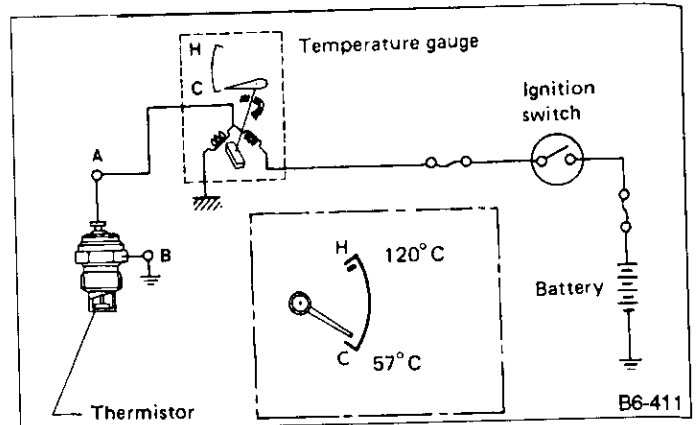


Fig. 109

It is normal if the readings of temperature gauge are within the tolerances of engine coolant temperature as shown in the following table against the standard resistance between point A and B indicated in the wiring diagram when ignition switch is "ON".

Readings of temperature gauge	Standard resistance	Temperature of engine coolant
50°C (122°F)	187.6 Ω	46 — 54°C (115 — 129°F)
120°C (248°F)	19 Ω	116 — 124°C (241 — 255°F)

3. FUEL GAUGE

Needle of fuel gauge remains indicating the amount of fuel in fuel tank after turning ignition switch to OFF position.

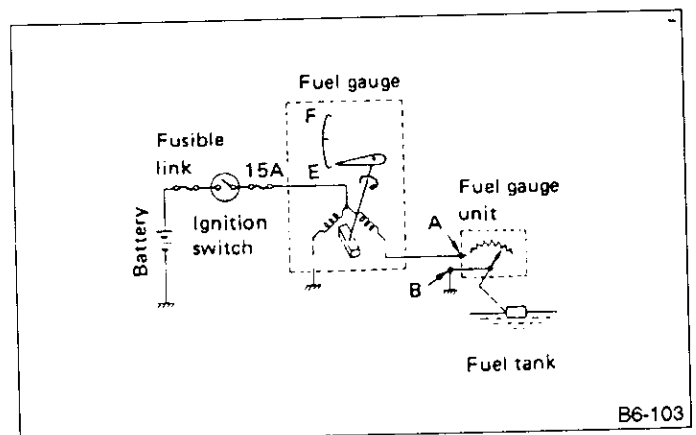


Fig. 110

It is normal if the readings of fuel gauge are within the tolerances of all length between "E" and "F" as shown in the following table, against the standard resistance between point A and B indicated in the wiring diagram when ignition switch "ON".

Readings of fuel gauge	Standard resistance	Tolerance of fuel gauge
E	92 Ω	+ 1/12 to - 1/24 of all length between "E" and "F"
1/2	(48.5 Ω)	—
F	5 Ω	+ 1/24 to - 1/12 of all length between "E" and "F"

4. TACHOMETER

It is normal if readings of tachometer are within the tolerances as shown in the following table, against the standard indicated speeds on tachometer tester.

Standard indicated speed (rpm)	1,000	2,000	3,000	4,000	5,000	6,000
Tolerance (rpm)						
- 30 to 60°C	+ 75	+ 145	+ 180	+ 220	+ 255	+ 290
(- 22 to 140°F)	- 75	- 110	- 110	- 110	- 100	- 95

5. SPEED SENSOR

Measure resistance between both terminals of combination meter and speed sensor, and ensure that resistance value varies.

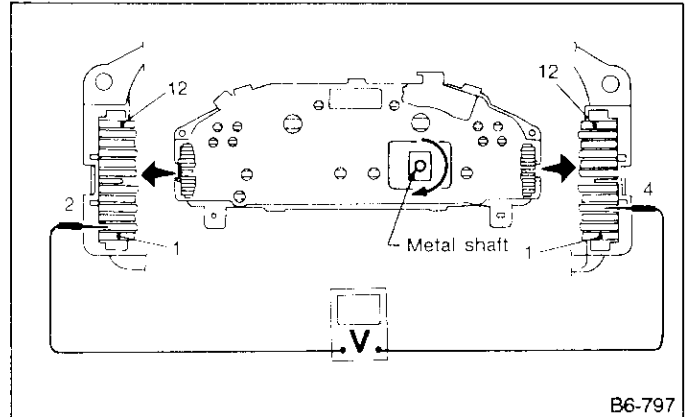


Fig. 111

22. Oil Pressure Indicator Light and Temperature Gauge

A: SCHEMATIC

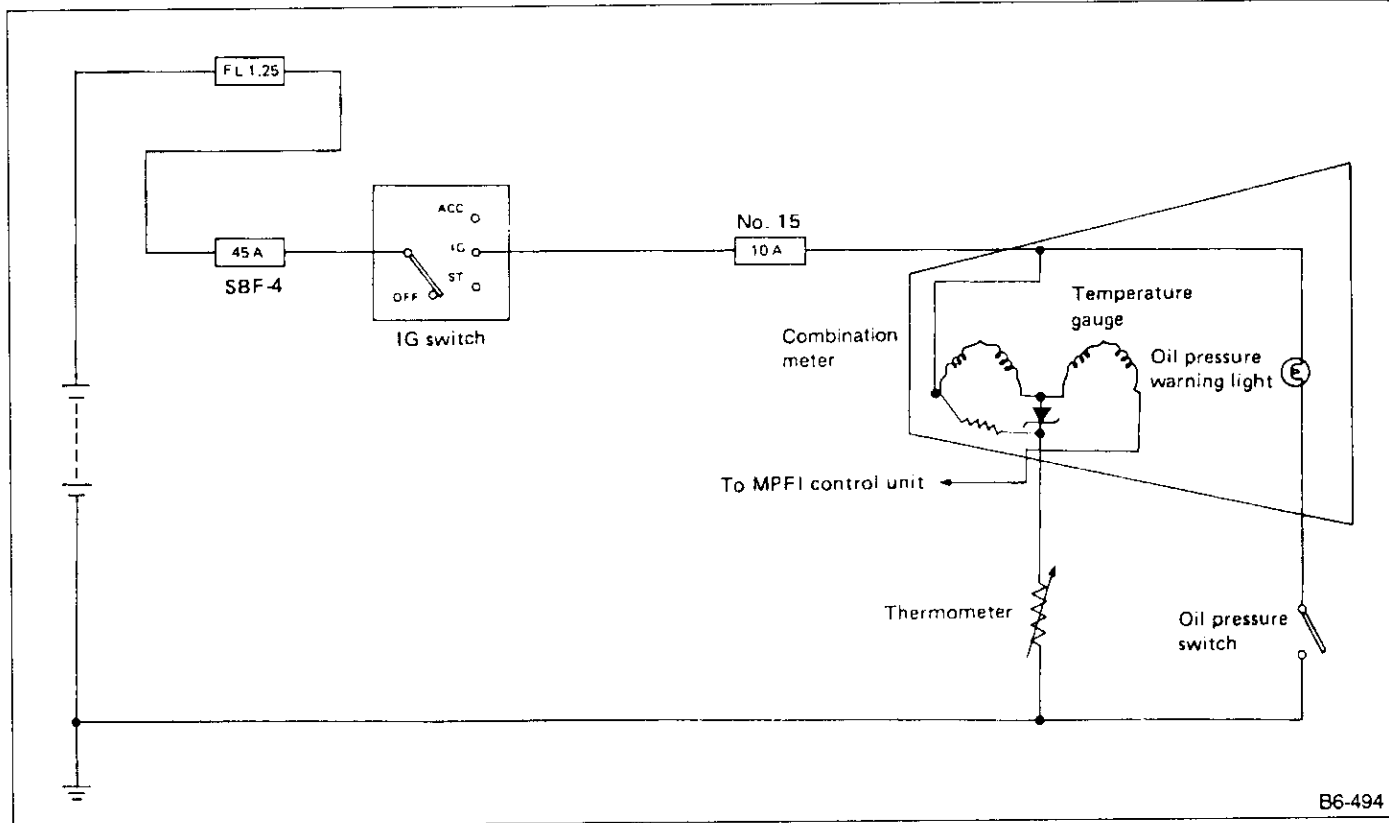


Fig. 112

23. Power Window

A: SCHEMATIC

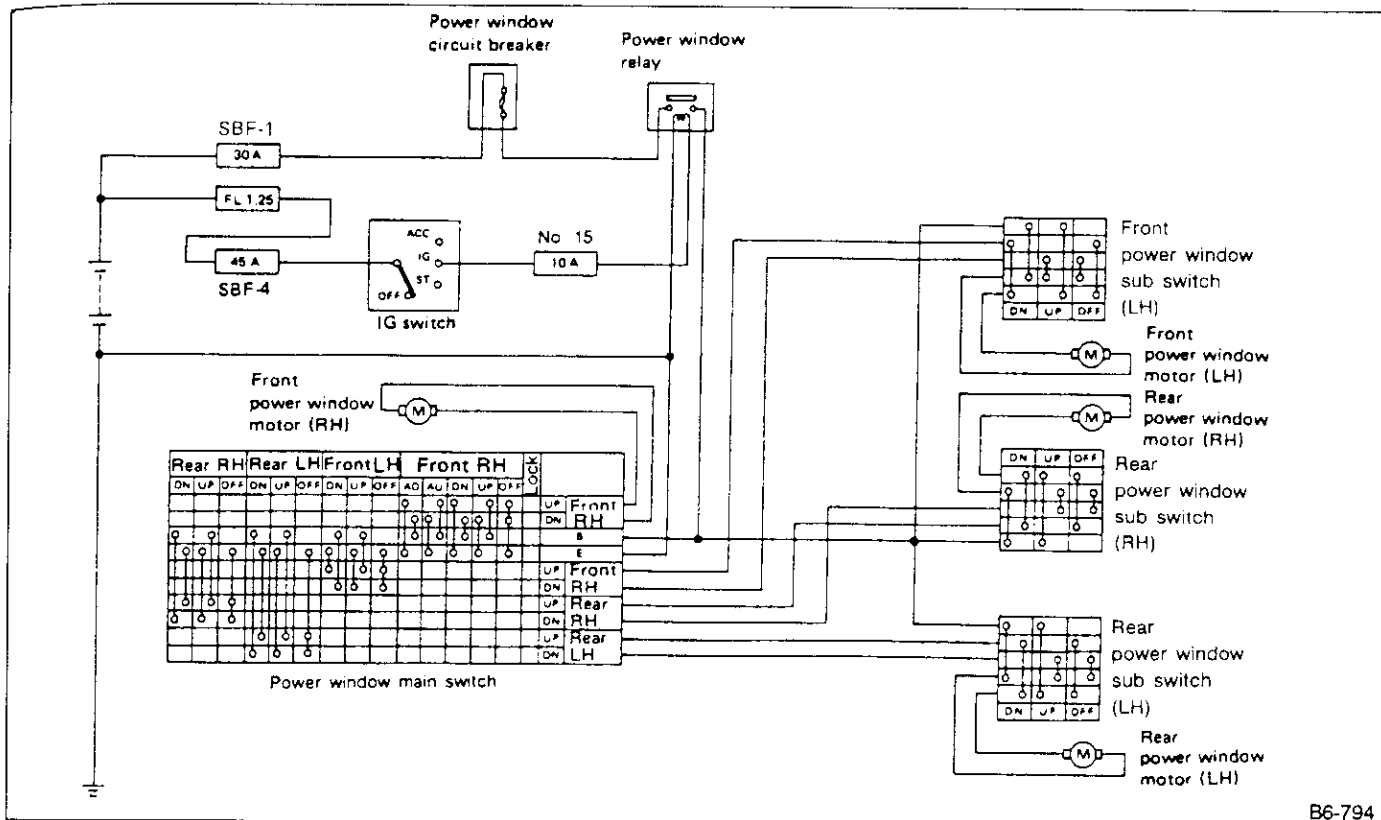


Fig. 113

B: REMOVAL AND INSTALLATION

1. MAIN SWITCH AND SUB SWITCH

- 1) Remove door trim. (Ref. to [5-2].)
 - 2) Main switch
 - (1) Remove pull handle
 - (2) Remove screws which secure switch, and remove switch.
 - Sub switch
- Remove main and sub switches using a small standard screwdriver.

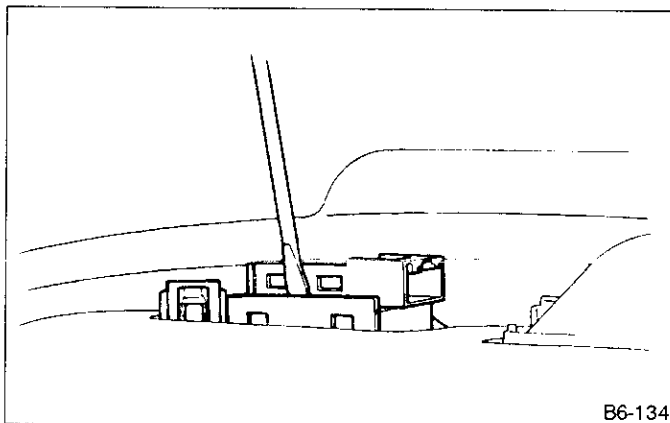


Fig. 114

2. POWER WINDOW MOTOR

(Ref. to [5-2].)

3. POWER WINDOW RELAY AND BREAKER

- 1) Remove front seat LH.
- 2) Remove cover side plate and roll up floor mat.
- 3) Remove attaching screws and remove switches and bracket as a unit.
- 4) Disconnect connector.

C: INSPECTION

1. MAIN SWITCH

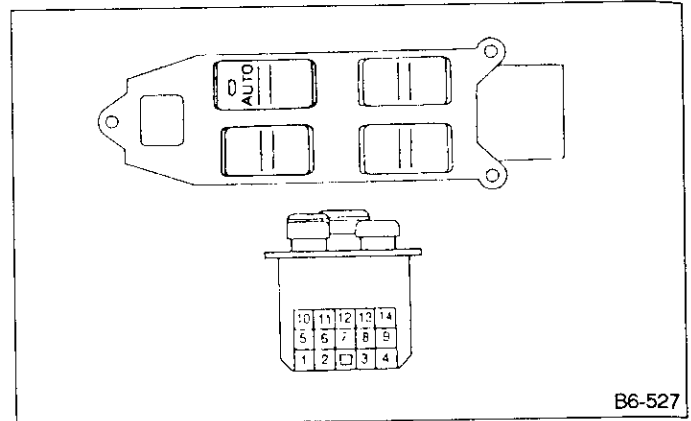


Fig. 115

Set main switch to each position and check continuity between terminals (indicated in table below).

Lock switch	Switch Position	Front RH				Front LH				Rear RH				Rear LH			
		12	6	5	7	12	9	8	7	12	13	14	7	12	11	10	7
NORMAL	UP	○	○	○	○	○	○	○	○	○	○	○	○	○	○	○	○
	OFF		○	○	○		○	○	○		○	○	○		○	○	○
	DOWN	○		○		○		○		○		○		○		○	
LOCK	UP	○	○	○	○	○	○			○	○			○	○		
	OFF		○	○	○		○	○			○	○			○	○	
	DOWN	○		○		○		○		○		○		○		○	

2. SUB SWITCH

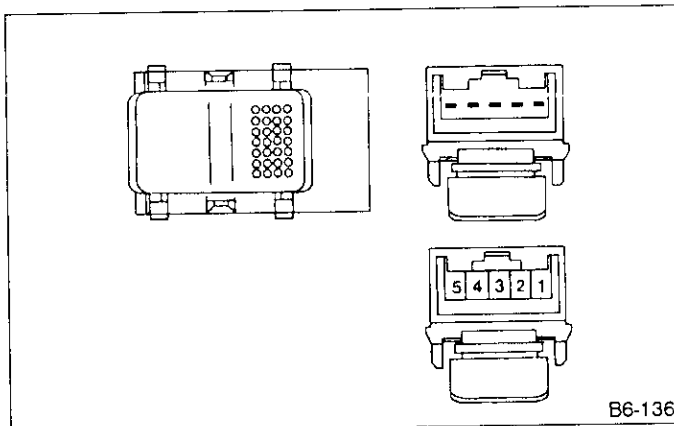


Fig. 116

Set sub switch to each position and check continuity between terminals (indicated in table below).

Terminal	3	4	2	5	1
Switch position					
UP	○			○	
↓	x	x			
OFF		○		○	
↓	x		x		
DOWN	○			○	

3. POWER WINDOW MOTOR

- 1) Connect battery to power window motor terminals to ensure that motor rotates properly.
- 2) Change polarity of battery connections to terminals to ensure that motor rotates in reverse direction.

4. POWER WINDOW RELAY

When current flows	Between terminals (2) and (4)	Continuity exists.
When current does not flow	Between terminals (2) and (4)	Continuity does not exist.
	Between terminals (1) and (3)	Continuity exists.

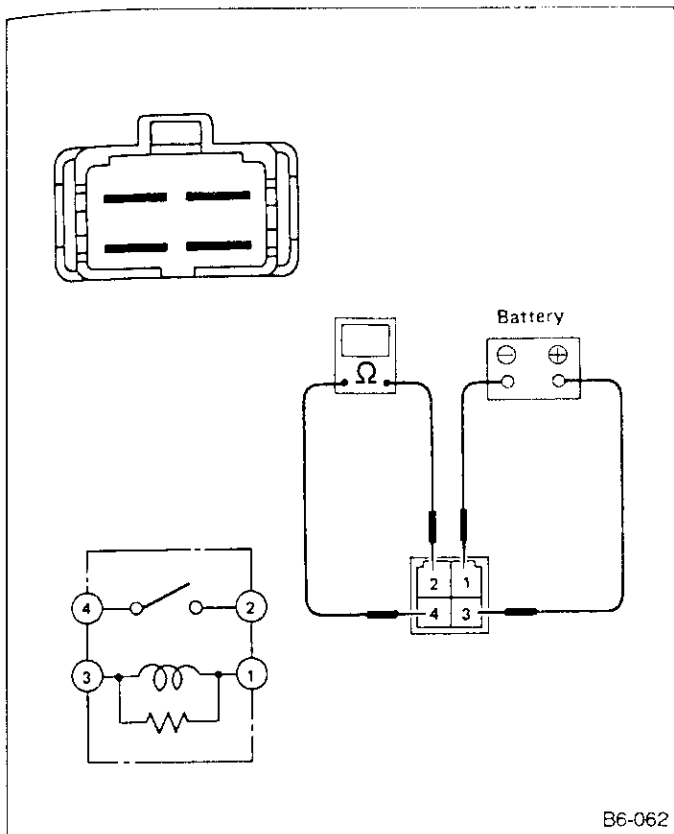
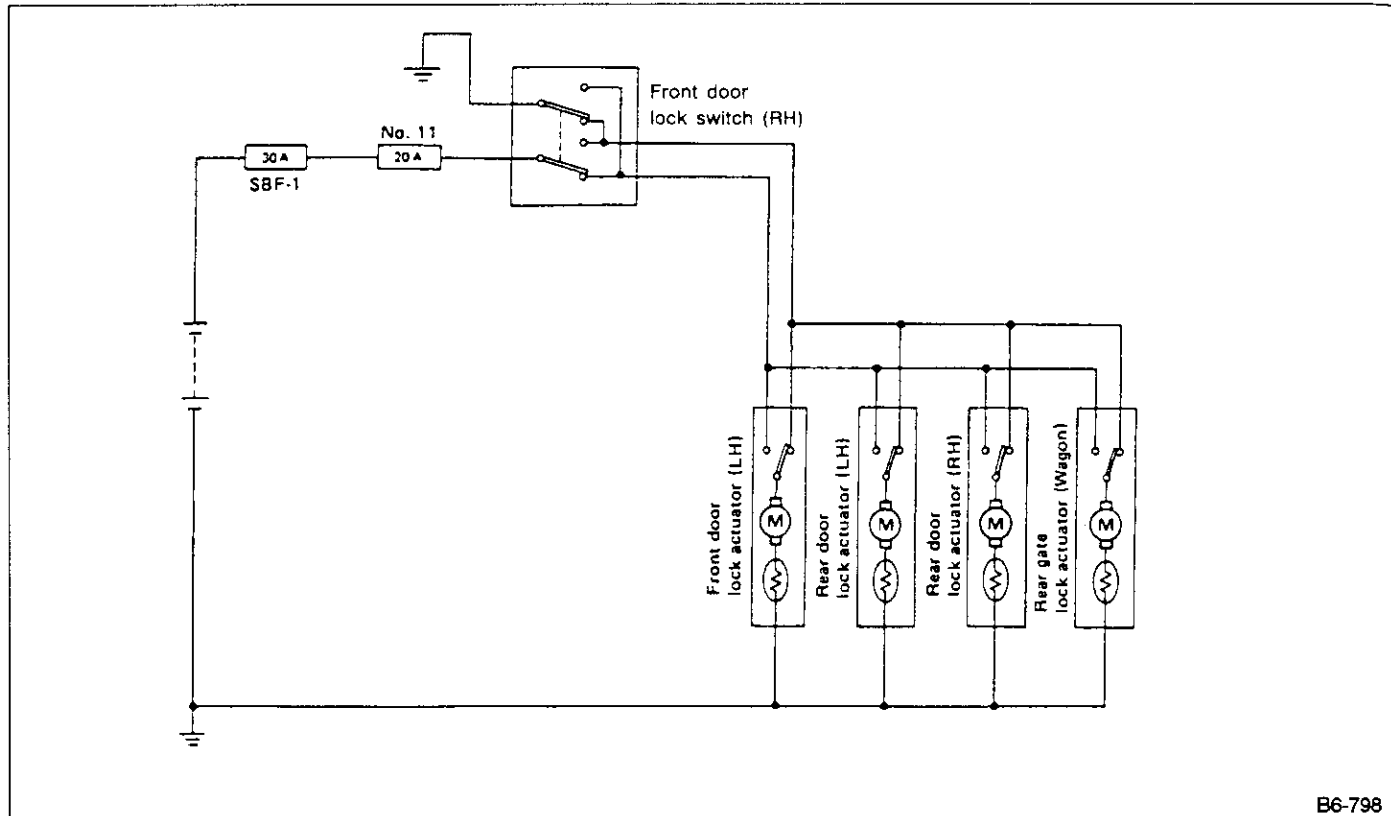


Fig. 117

Check continuity between terminals (indicated in table below) when battery is connected to terminal (3) and terminal (1) is grounded.

24. Door Lock

A: SCHEMATIC



B6-798

Fig. 118

B: REMOVAL AND INSTALLATION

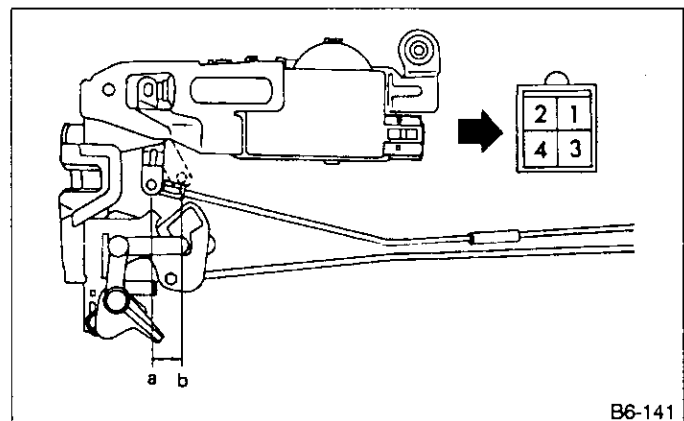
1. FRONT DOOR LOCK ACTUATOR
2. REAR DOOR LOCK ACTUATOR
3. REAR GATE LOCK ACTUATOR

⟨Ref. to [5-2].⟩

C: INSPECTION

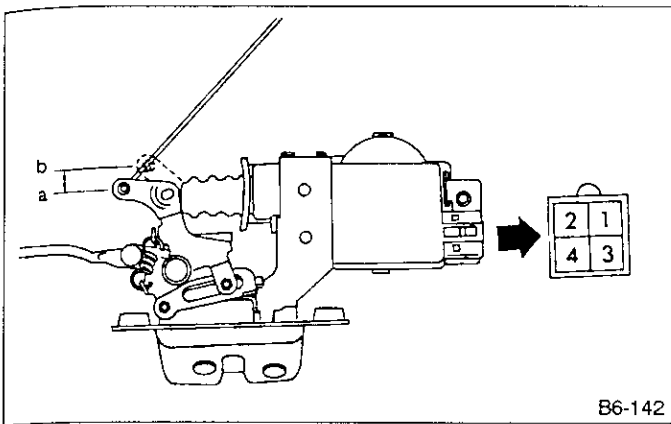
1. DOOR LOCK ACTUATOR (except for driver's side)

- 1) Move rod to position (a). Ensure that rod moves to position (b) when terminal (4) is connected to battery and terminal (2) is grounded.
- 2) Move rod to position (b). Ensure that rod moves to position (a) when terminal (3) is connected to battery and terminal (2) is grounded.



B6-141

Fig. 119



2. REAR GATE LOCK ACTUATOR

- 1) Move rod to position (a). Ensure that rod moves to position (b) when terminal (4) is connected to battery and terminal (2) is grounded.
- 2) Move rod to position (b). Ensure that rod moves to position (a) when terminal (3) is connected to battery and terminal (2) is grounded.

Fig. 120

25. Horn and Cigarette Lighter

A: SCHEMATIC

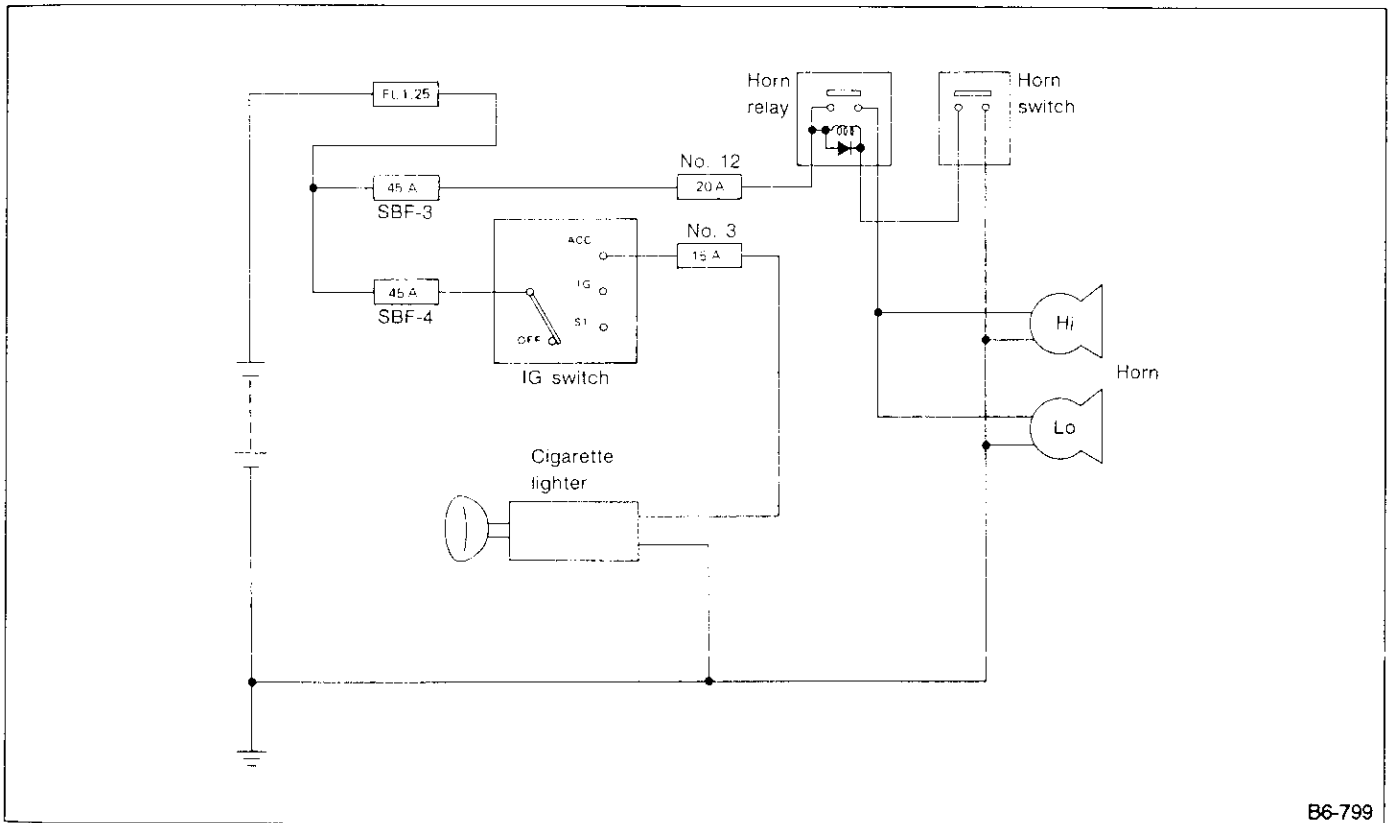


Fig. 121

B: REMOVAL AND INSTALLATION**1. HORN**

- 1) Disconnect left-hand headlight connector.
- 2) Remove attaching bolts.

Tightening torque:

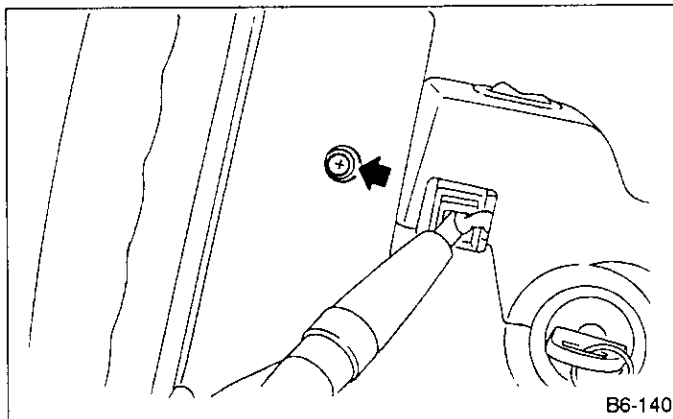
13 — 23 N·m

(1.3 — 2.3 kg-m, 9 — 17 ft-lb)

- 3) While removing horn, disconnect connector.
 - a. Install "Lo" horn on the left, and "Hi" horn on the right, as viewed from front of vehicle.
 - b. After installing horn, connect electrical wire with it by keeping some slack to prevent wire from disconnecting by its vibration.

2. HORN SWITCH

- 1) Remove screws which secure horn switch to the base of steering wheel.



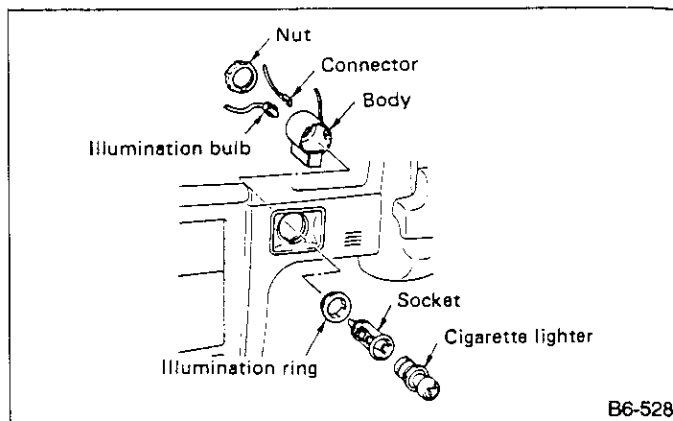
B6-140

Fig. 122

- 2) Remove horn pad and disconnect connector.

3. CIGARETTE LIGHTER

- 1) Remove instrument panel lower cover.
- 2) Disconnect connectors from cigarette lighter.
- 3) Turn illumination & socket 45° counterclockwise and remove.
- 4) Loosen nut. Remove body.



B6-528

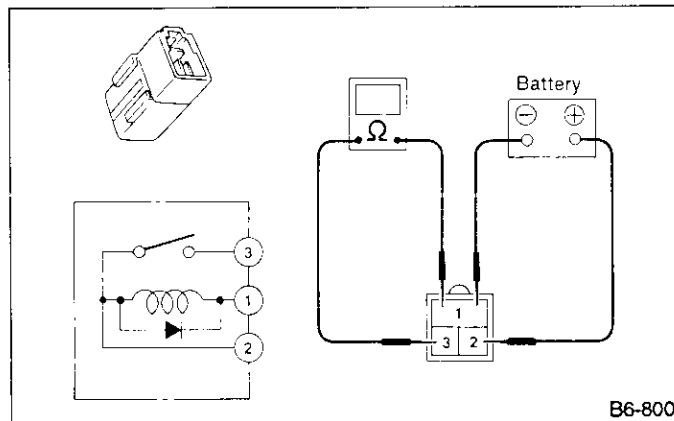
Fig. 123

- a. Align socket with cutout portion of instrument panel during installation.
- b. In case of replacing cigarette lighter, use genuine part only and always replace both plug and socket combination.

C: INSPECTION**1. HORN SWITCH**

Ensure that horn switch is free from the following defects:

- 1) Burned or shorted contacts
- 2) Broken or weak spring
- 3) Damaged harness
- 4) Worn or corroded mating surface of horn plate

2. HORN RELAY

B6-800

Fig. 124

- 1) Check continuity between terminals (indicated in table below) when battery is connected to terminal (2) and terminal (1) is grounded.

When current flows	Between terminals (2) and (3)	Continuity exists.
When current does not flow	Between terminals (2) and (3)	Continuity does not exist.
	Between terminals (1) and (2)	Continuity exists.

3. HORN

- 1) Check the adjusting screw for looseness.
- 2) Connect battery to horn to ensure that it sounds.

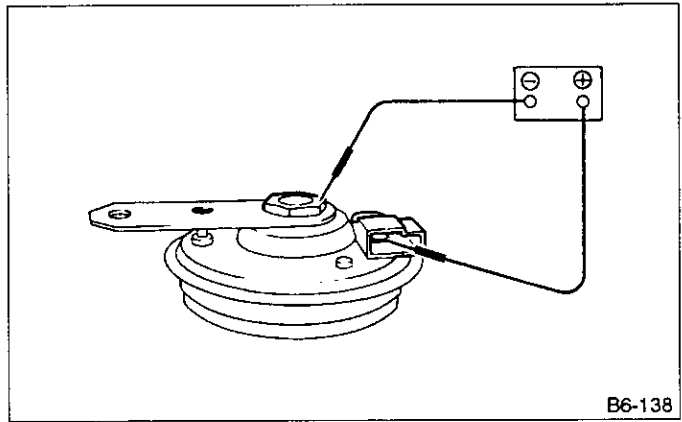


Fig. 125

4. CIGARETTE LIGHTER

- 1) Remove plug. Check element's contact for wear, and element for accumulation of ashes, foreign particles, etc.
- 2) Check element for discontinuity.
- 3) Remove socket and clean element. Check for wear or foreign particles on element's contact and mating surface.
- 4) Ensure that cigarette lighter returns within 20 seconds after it is turned ON.

26. Sunroof, Spot Light and Vanity Mirror

A: SCHEMATIC

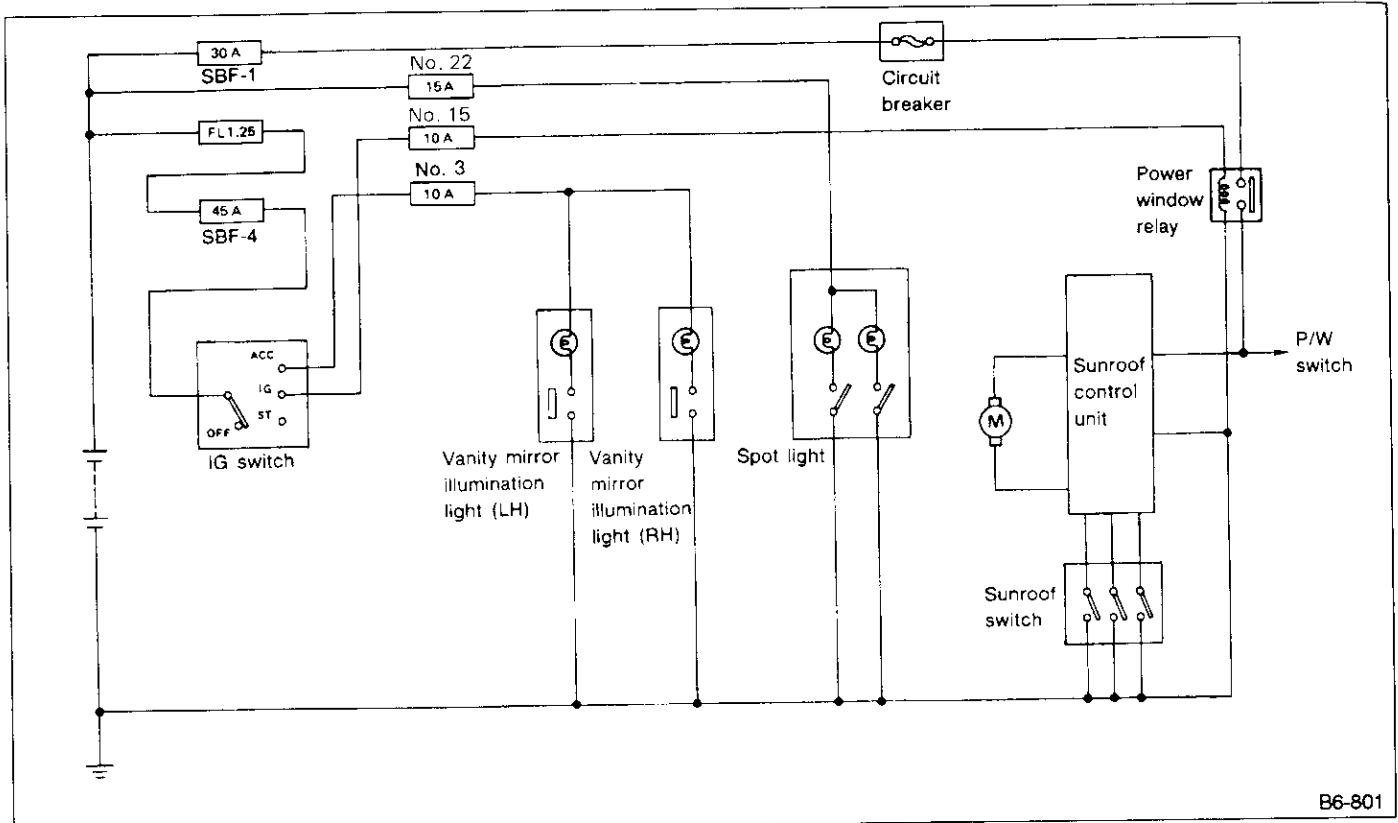


Fig. 126

B: REMOVAL AND INSTALLATION

1. SUNROOF

<Ref. to [5-1].>

2. SUNROOF SWITCH AND SPOT LIGHT

- 1) Remove lens and attaching screws.
- 2) Remove sunroof switch and connector.

3. VANITY MIRROR ILLUMINATION LIGHT

- 1) Remove screws which secure sun visor.
- 2) Remove sun visor and connector.

C: INSPECTION

1. SUNROOF RELAY

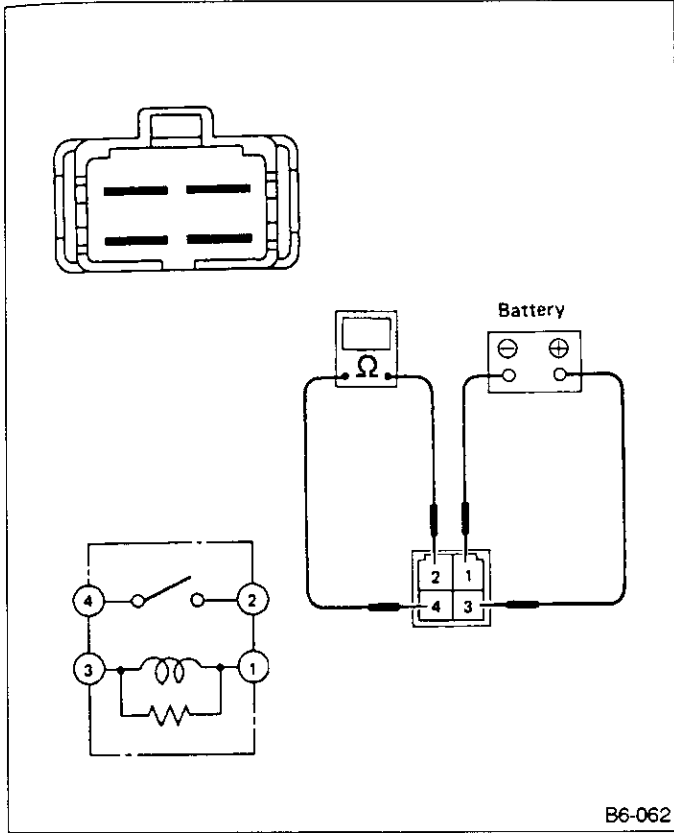
Check continuity between terminals (indicated in table below) when battery is connected to terminal (1) and terminal (3) is grounded.

When current flows	Between terminals (2) and (4)	Continuity exists.
When current does not flow	Between terminals (2) and (4)	Continuity does not exist.
	Between terminals (1) and (3)	Continuity exists.

2. SUNROOF SWITCH

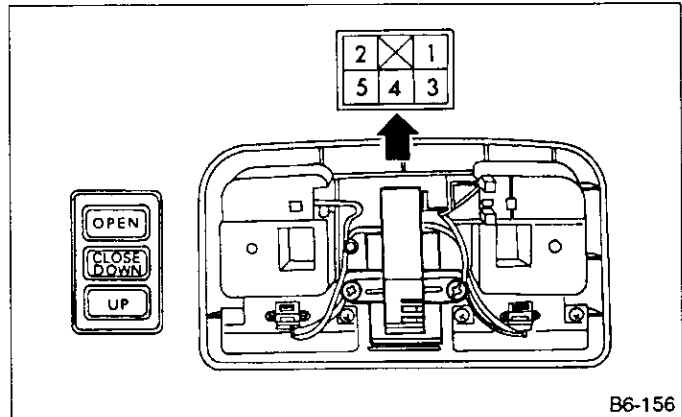
Move sunroof switch to each position and check continuity between terminals (indicated in table below).

Terminal	1	2	3	4	5
Switch position					
OPEN	○	—	○		
CLOSE/DOWN			○	—	○
UP			○	—	○



B6-062

Fig. 127

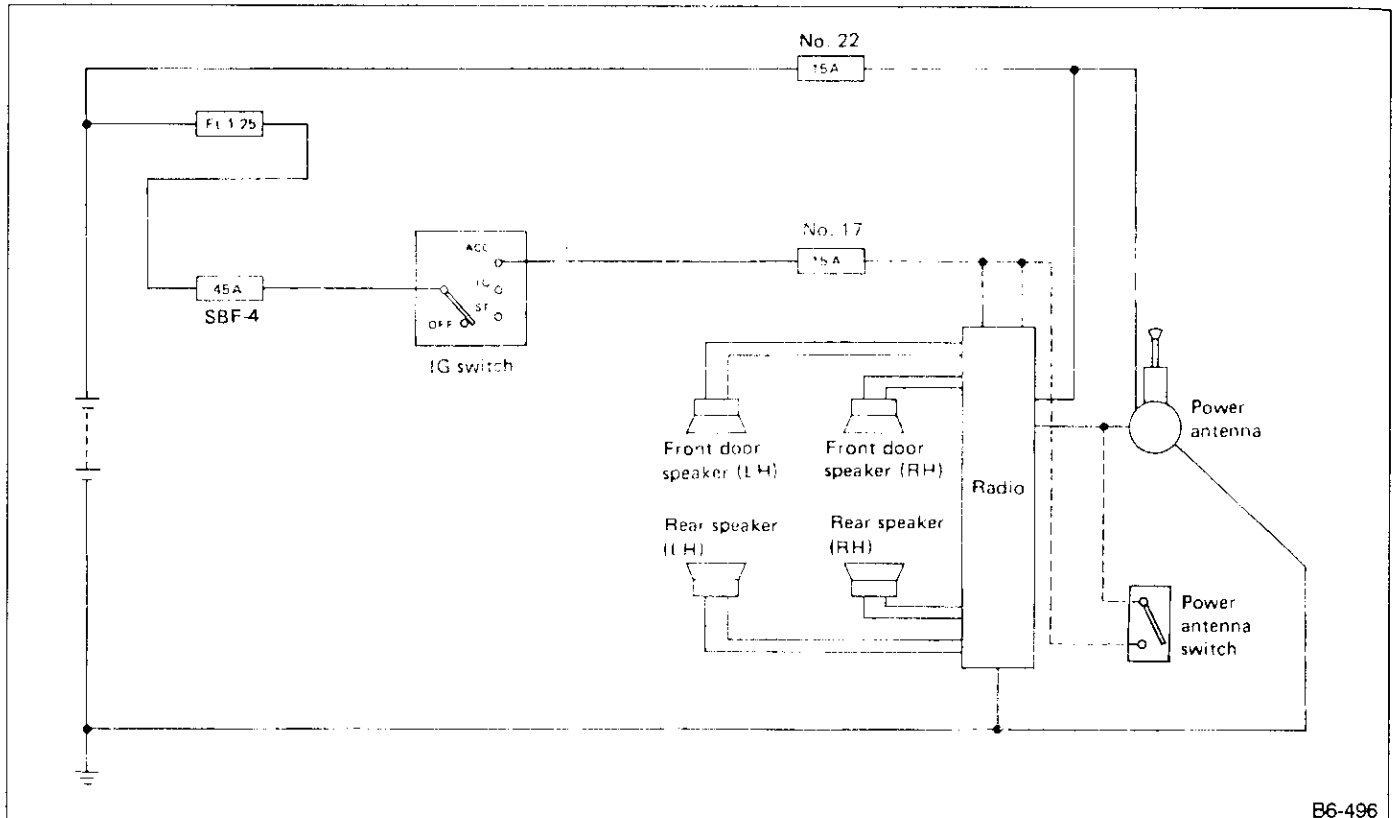


B6-156

Fig. 128

27. Radio and Antenna

A: SCHEMATIC



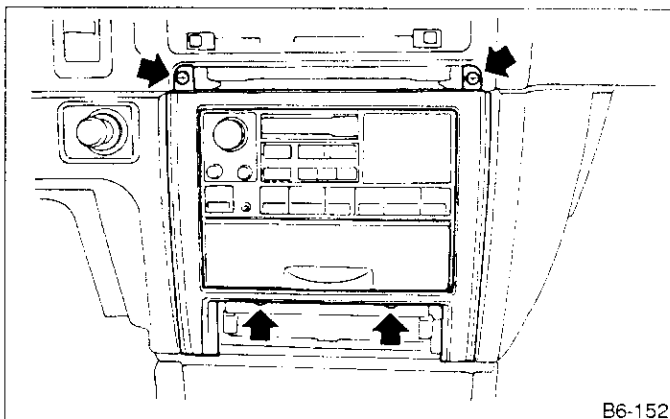
B6-496

Fig. 129

B: REMOVAL AND INSTALLATION

1. RADIO BODY

- 1) Remove cup holder and ash tray.
- 2) Remove screws which secure center panel. Remove center panel.

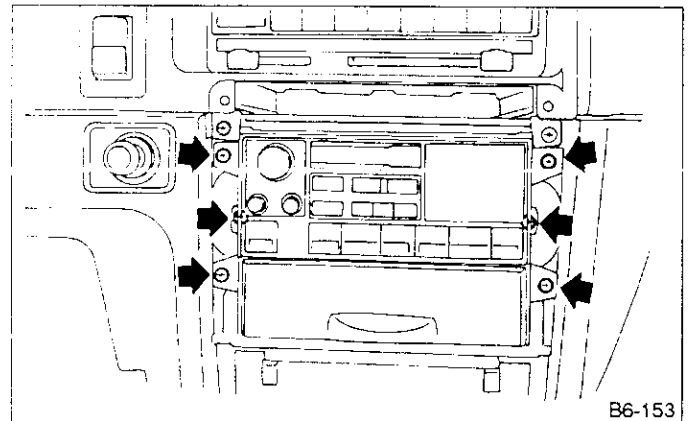


B6-152

Fig. 130

- 3) Remove antenna plug from left side of console box.

- 4) Remove fitting screws, and slightly pull radio out of instrument panel.



B6-153

Fig. 131

- 5) Disconnect electric connectors and antenna feeder cord and take out radio.

2. POWER ANTENNA

- 1) Remove trim panel.
- 2) Unroll antenna insulator (WAGON) and disconnect connector and antenna feeder.

- 3) Remove bolts.

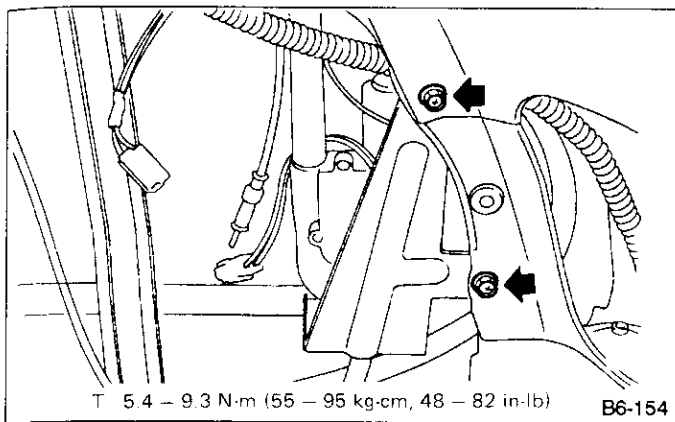


Fig. 132

- 4) Pull antenna rod out from lower side.

Insert drain tube into its original position during installation.

3. FRONT SPEAKER

- 1) Remove door trim and disconnect connector. (Ref. to [5-2].)
- 2) Remove screws which secure front speaker. Remove speaker.

4. REAR SPEAKER (WAGON)

- 1) Remove luggage area cover and holder.
- 2) Fold rear backrest forward.
- 3) Remove cover and nuts which secure speaker bracket.
- 4) Remove speaker and disconnect connector.

5. REAR SPEAKERS (SEDAN)

- 1) Remove rear cushion and rear backrest.
- 2) Remove left and right rear quarter trim panels.
- 3) Remove rear shelf trim panels.
- 4) Remove screws which secure rear speakers.
- 5) Disconnect connector and remove speakers.

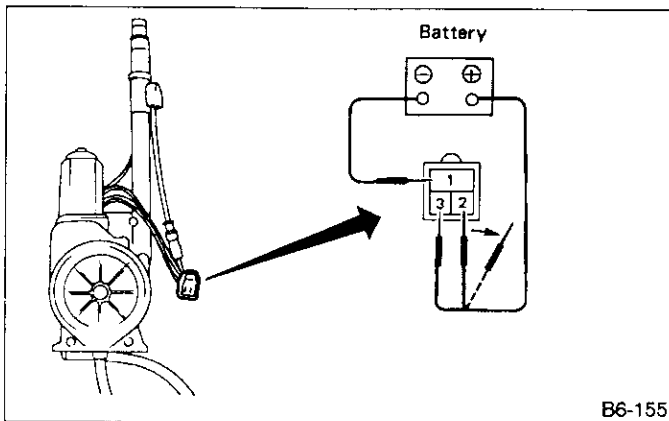


Fig. 133

C: INSPECTION

1. POWER ANTENNA

- 1) Connect battery positive terminal to terminal (3) and connect terminal (1) to ground. Ensure that antenna rod extends properly when battery positive terminal is connected to terminal (2).
- 2) Ensure that antenna rod retracts properly when battery positive terminal is disconnected from terminal (2).

28. Mode Selector and Blower Motor

A: SCHEMATIC

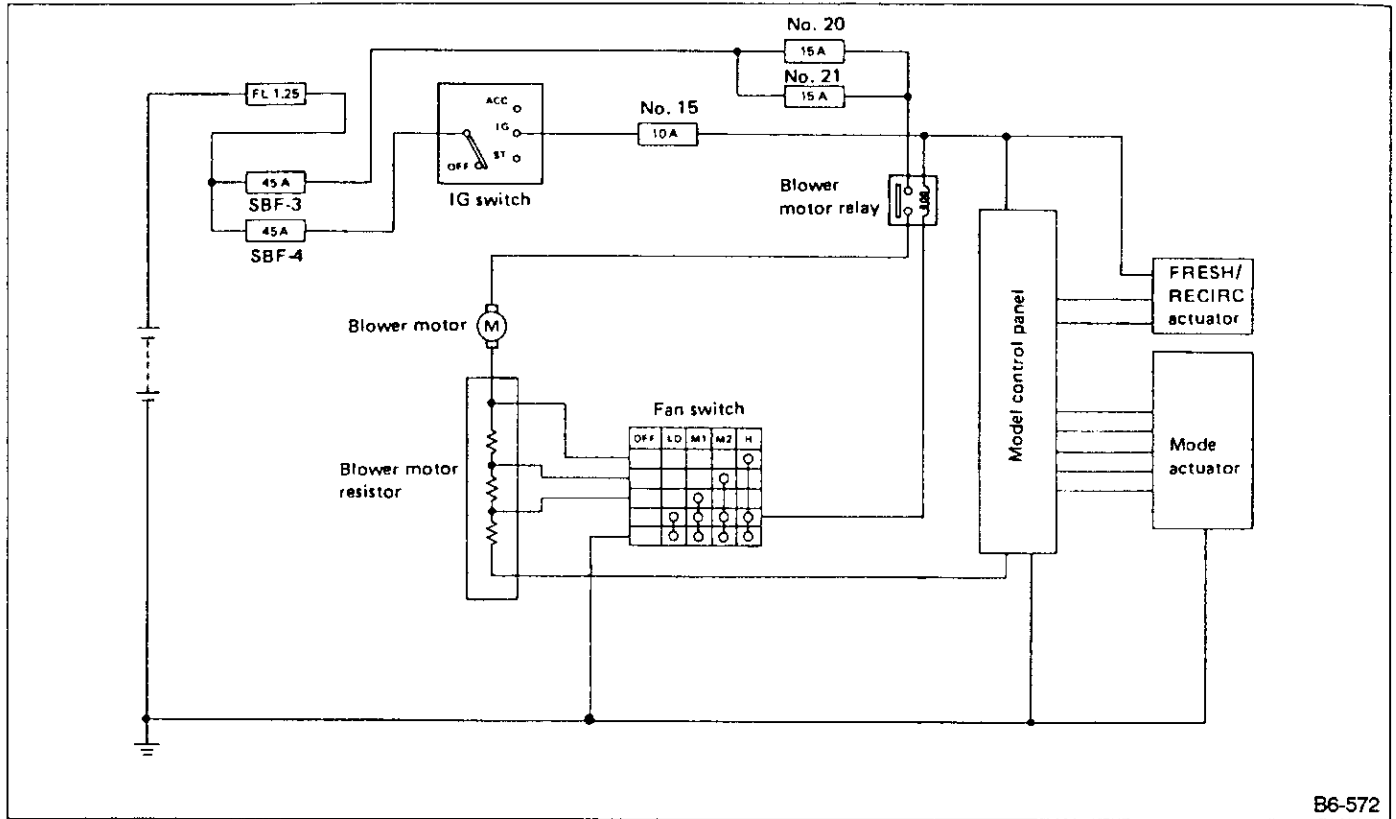


Fig. 134

B: REMOVAL AND INSTALLATION

<Ref. to [4-6].>

C: INSPECTION

<Ref. to [4-6].>

C: INSPECTION

1. REMOTE CONTROL REARVIEW MIRROR SWITCH

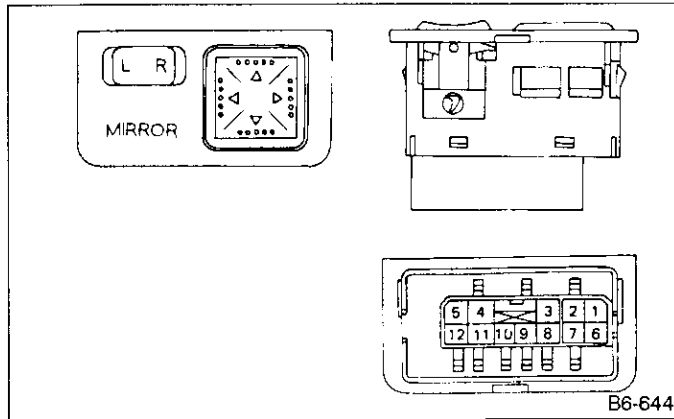


Fig. 136

Move rearview mirror switch to each position and check continuity between terminals (indicated in table below).

Position Terminal	Mirror switch					Left/Right changing switch		
	OFF	Right	Left	Upper	Down	Left	N	Right
4		○	○	○	○			
10		○	○	○	○	○	○	○
11		○	○	○	○	○	○	○
1								○
6						○	○	○
2						○	○	○
7						○	○	○
8								
9								
5					○			
12					○			

2. REARVIEW MIRROR

- 1) Remove door trim. (Ref. to [5-2].)
- 2) Disconnect 6-pin connector.

Check to ensure that rearview mirror moves properly when battery voltage is applied to terminals (indicated in table below).

Operation	Terminal connection	
	(+)	(-)
UP	1	3
DOWN	3	1
RIGHT	3	2
LEFT	2	3

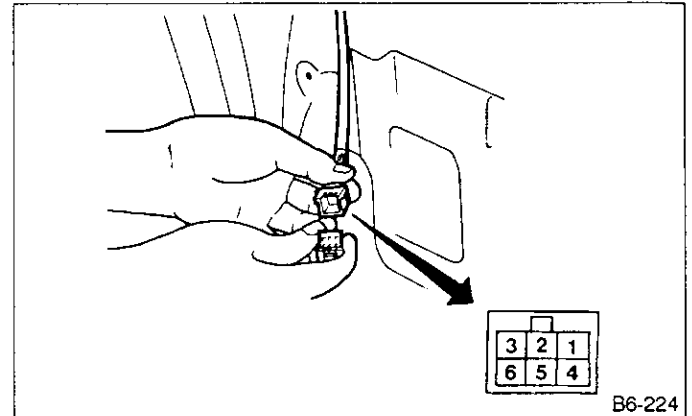


Fig. 137

30. Pneumatic Suspension (Air Suspension)

A: SCHEMATIC

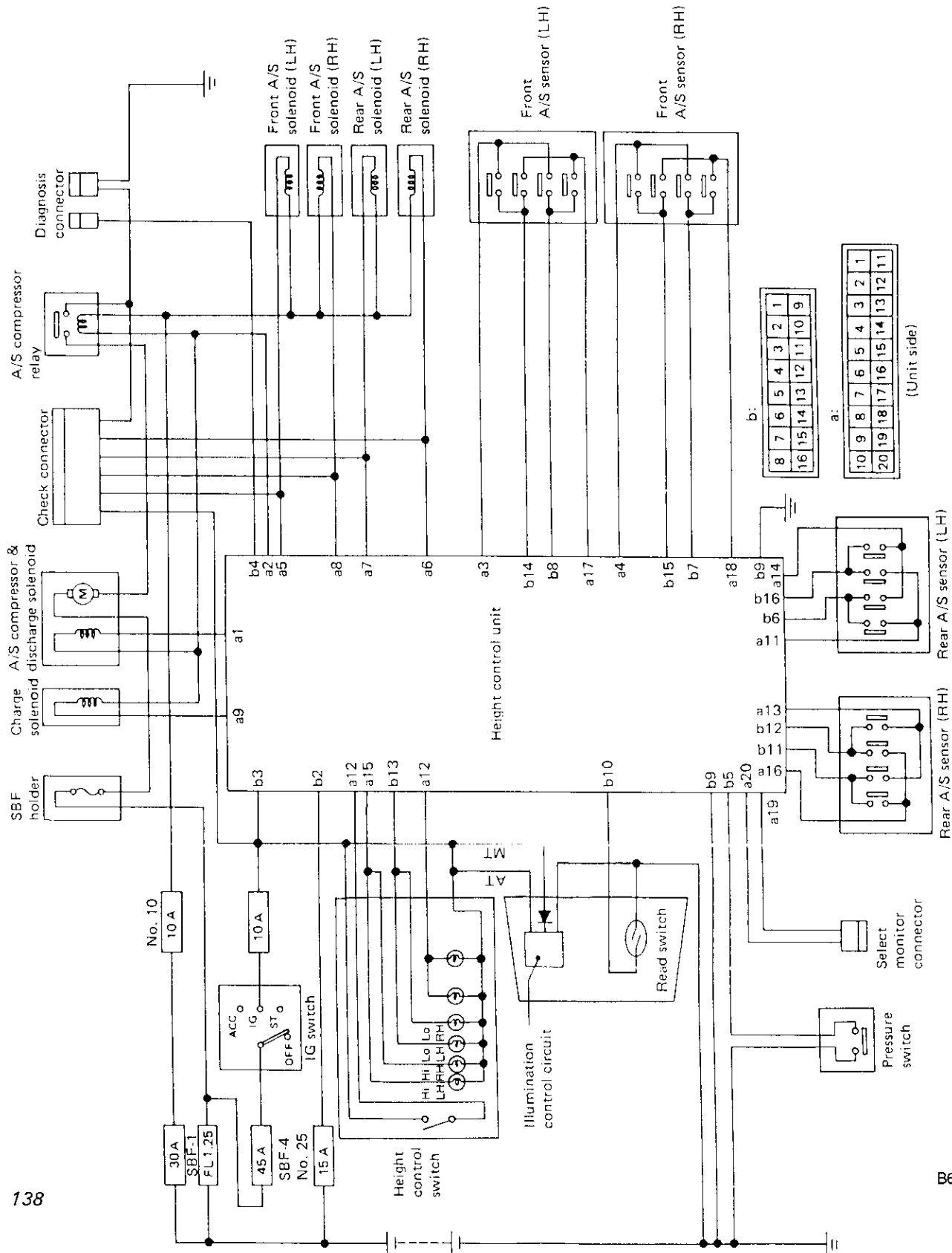
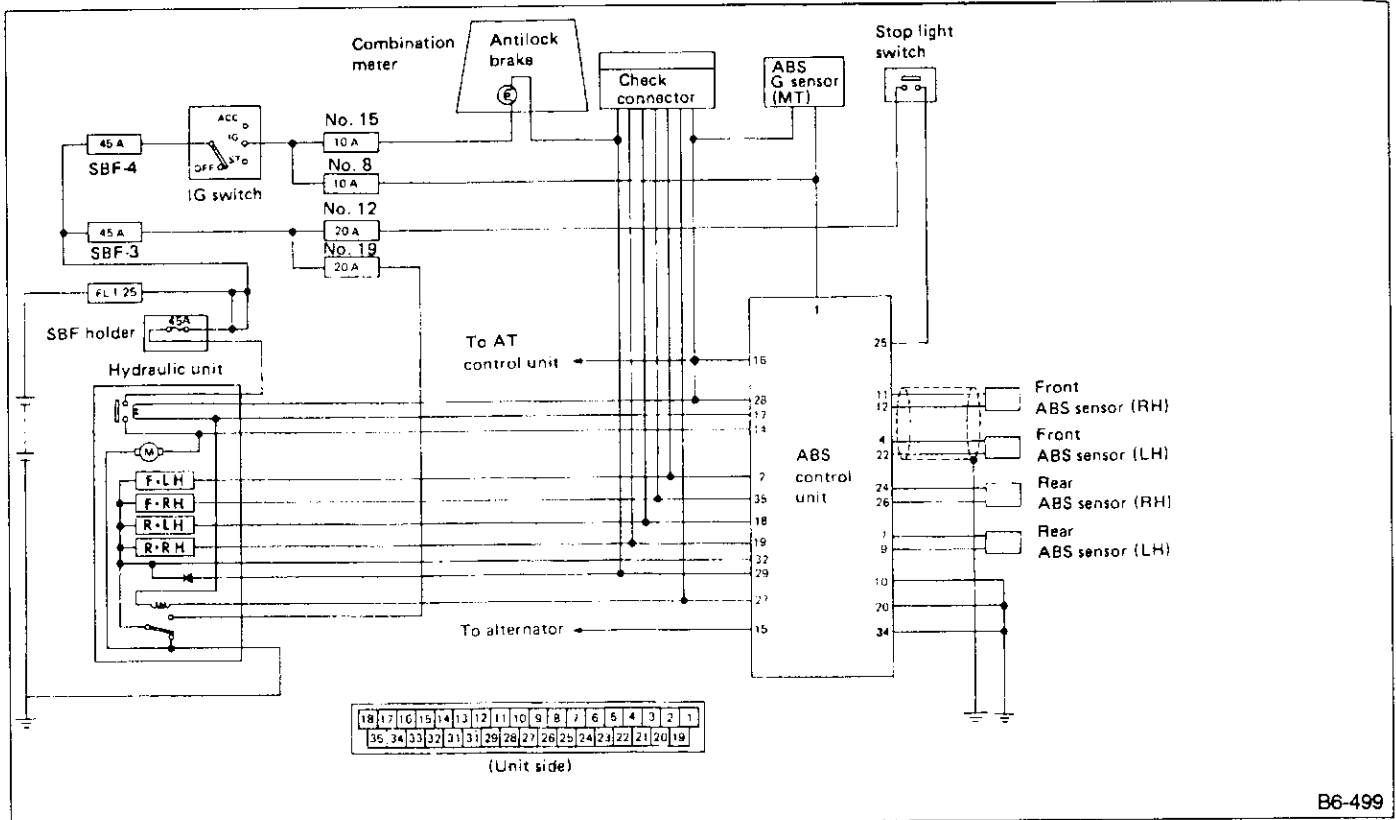


Fig. 138

B6-648

31. Antilock Brake System

A: SCHEMATIC

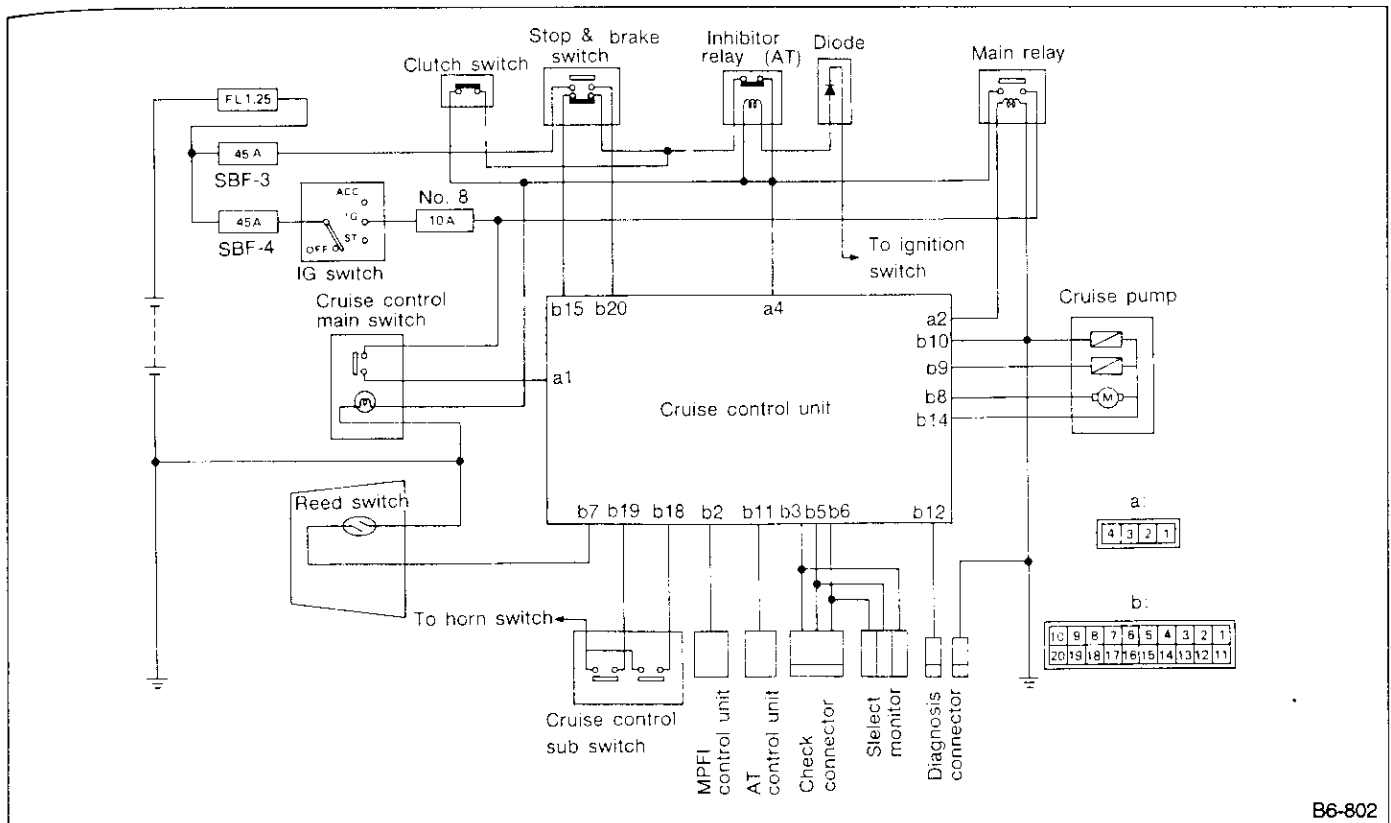


B6-499

Fig. 139

32. Cruise Control

A: SCHEMATIC



B6-802

Fig. 140

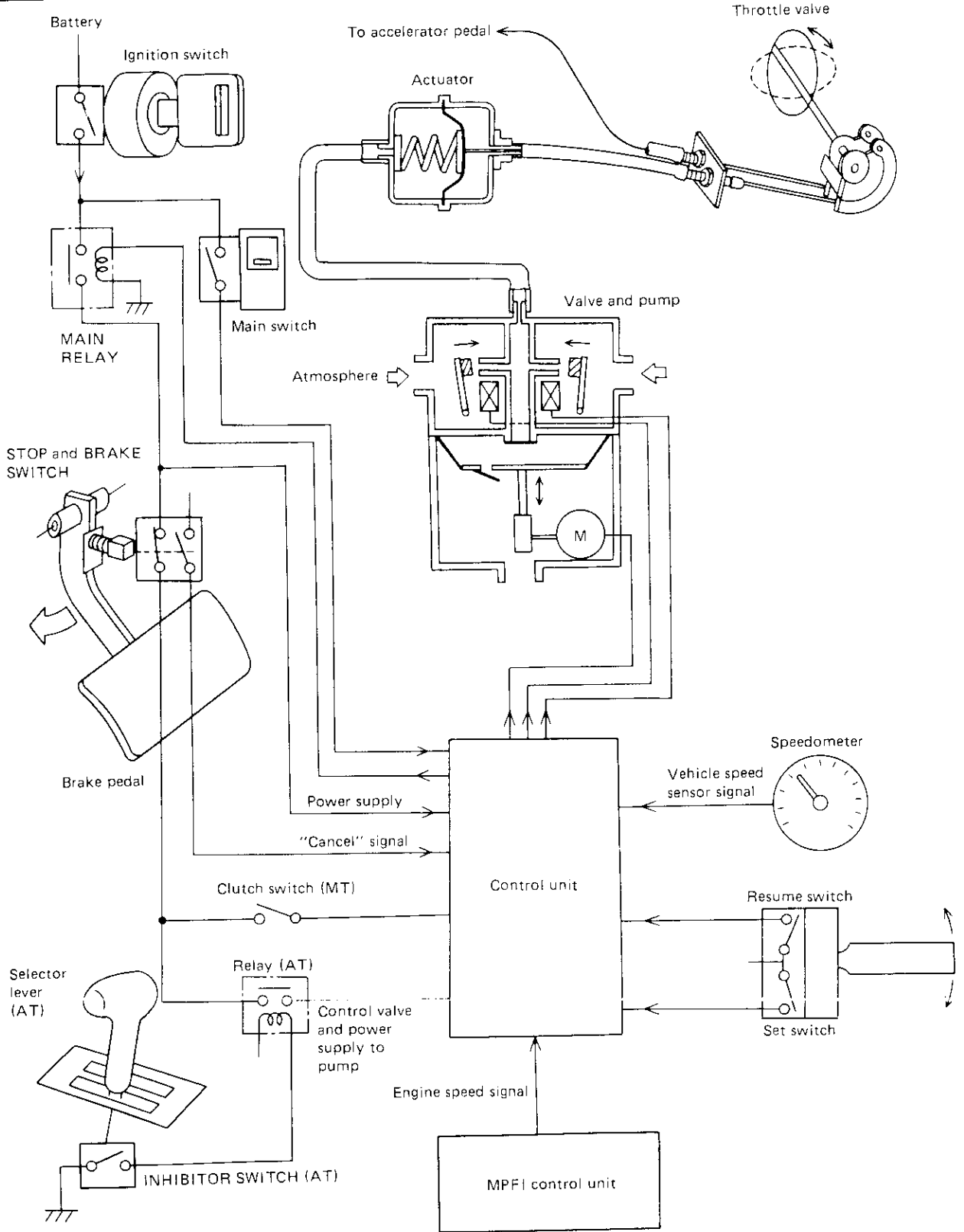


Fig. 141

B6-664

B: DESCRIPTION**1. CONTROL AND OPERATION**

Constant speed control	When actual driving speed is higher than "set" speed, cruise control system intermittently opens vent valve and moves throttle valve toward the close position. This occurs while comparing actual driving speed with "set" speed. When actual driving speed is lower than "set" speed, the system intermittently activates vacuum pump to move throttle valve toward the "open" direction.
"Set" control	When SET/COAST switch is pressed with main switch ON while is being driven a specified greater than 40 km/h (25 MPH), current flows so that vent and safety valves close. This then causes vacuum pump to intermittently activate to set throttle valve at position corresponding with accelerator pedal depression. Thus, vehicle is being driven at constant speed.
Deceleration control	When SET/COASTS switch is turned ON while vehicle is cruising, vent valve intermittently opens, partially closing throttle valve. This causes the vehicle to decelerate. When the switch is turned OFF, vehicle speed is stored in memory and vehicle is constantly driven at that speed.
Acceleration control	When RESUME/ACCEL switch is turned ON while vehicle is cruising, vacuum pump intermittently activates to partially open throttle valve. This causes vehicle to accelerate. When the switch is turned OFF, vehicle speed is stored in memory and vehicle is constantly driven at that speed.
Resume control	When RESUME ACCEL switch is turned ON after cruise control is released, vehicle speed returns to that speed which was stored in memory just before cruise control was released. However, this occurs only when vehicle is being driven at a speed greater than 30 km/h (19 MPH).
Manual cancel control	When any of the following signals are entered, vent valve and safety valve open to release cruising speed. (1) Stop light switch ON signal (Brake pedal depressed) (2) Brake switch OFF signal (Brake pedal depressed) (3) Clutch switch OFF signal (Clutch pedal depressed — MT) (4) Inhibitor switch ON signal (Selector lever set to "N" — AT)
Low speed limit control	When vehicle speed drops below 30 km/h (19 MPH), cruise control is automatically canceled. The memorized speed will also be cleared. Cruise control at speed lower than 40 km/h (25 MPH) cannot be effected.
Release valve control	When vehicle speed increases 10 km/h (6 MPH) greater than memorized speed while vehicle is cruising (downgrade, etc.), actuator's vent valve as well as safety valve are turned OFF (to open to atmospheric pressure) so that vehicle decelerates. When vehicle decelerates within 8 km/h (5 MPH) greater than the memorized speed, vent and safety valve are turned ON (to shut out atmospheric pressure) so that cruise control resumes.
Auto. cancel control	When any of the following signals are entered while vehicle is cruising, actuator's vent valve as well as safety valve are turned OFF (to shut out atmospheric pressure). This cancels cruise control. (a) When vehicle speed drops below low speed limit 30 km/h (19 MPH), (b) When actuator's vent valve, safety valve, vacuum pump motor or harness circuit is shorted, (c) When actuator's vent valve, safety valve, vacuum pump or harness circuit are discontinued, (d) When ON signals are simultaneously emitted from SET/COAST and RESUME/ACCEL switches, or (e) When a vehicle speed signal that implies speed variation of greater than ± 25 km/h (± 16 MPH) per second is entered.

Cruise control unit compares the actual car speed detected by feedback signals from speed sensor incorporated in speedometer with the speed set in the memory memorized when set switch was turned on. A signal is then transmitted according to the difference between the two speeds.

This signal is transmitted to solenoid valves of valve ASSY located in engine compartment. The movement of actuator operates throttle valve through accelerator pedal and cable, thereby keeping the car speed constant.

2. SYSTEM CONSTRUCTION

Unit	Name	Function	Set	Cancel	Resume	Coast	Vehicle speed
Output signal (sensors)	Main switch	Supplies battery voltage to control unit after main switch is turned ON (with ignition switch ON).	<input type="radio"/>	<input type="radio"/>	<input type="radio"/>	<input type="radio"/>	<input type="radio"/>
	SET/COAST switch	Sends a SET/COAST signal to control unit.	<input type="radio"/>			<input type="radio"/>	
	RESUME/ACCEL switch	Sends a RESUME/ACCEL signal to control unit.			<input type="radio"/>		
	Brake switch (NC)	Disconnects power supply to control valve and vacuum pump.	<input type="radio"/>	<input type="radio"/>			
	Stop light switch (NO)	Stops control unit's function and disconnects power supply to control valve and vacuum pump.	<input type="radio"/>	<input type="radio"/>			
	Clutch switch (NC) or inhibitor switch (NO)	Disconnects power supply to control valve and vacuum pump.	<input type="radio"/>	<input type="radio"/>			
	Set signal						<input type="radio"/>
	Vehicle speed sensor (in combination meter)	Controls vehicle speed.	<input type="radio"/>	<input type="radio"/>	<input type="radio"/>	<input type="radio"/>	<input type="radio"/>
Control section	Built-in relay	A safety device to protect system from damage.	<input type="radio"/>	<input type="radio"/>	<input type="radio"/>	<input type="radio"/>	<input type="radio"/>
Output signal (actuators)	Vacuum pump motor	Produces vacuum pressure to activate vacuum diaphragm.	<input type="radio"/>	<input type="radio"/>	<input type="radio"/>		<input type="radio"/>
	Vent valve	Activates when controlling vehicle speed. (Vacuum pressure → Atmospheric pressure)	<input type="radio"/>	<input type="radio"/>	<input type="radio"/>	<input type="radio"/>	<input type="radio"/>
	Safety valve	Opens to introduce atmospheric pressure into system if vent valve malfunctions.	<input type="radio"/>	<input type="radio"/>	<input type="radio"/>	<input type="radio"/>	<input type="radio"/>

3. FAIL-SAFE FUNCTION

Fail-safe item	Cancel conditions	Operation
Cancels erroneous switch operation	A: <ul style="list-style-type: none"> • SET/COAST switch ON • RESUME/ACCEL switch ON B: <ul style="list-style-type: none"> • Brake switch OFF • Stop light switch ON (Brake pedal depressed) • Clutch switch OFF (Clutch pedal depressed) • Inhibitor switch ON (Shift lever set to "N") 	When signals emitted from A and B groups are simultaneously entered, cruise control and memory speed will be or are canceled. System resumes after SET/COAST switch is turned ON again.
Cancels erroneous circuit operation	<ul style="list-style-type: none"> • When control unit stops or erroneously operates. • When variations in vehicle speed signal is greater than 25 km/h/sec (16 MPH/sec). • When relay built into control unit remains ON. • When vacuum motor terminal or vent valve when motor drive circuit or vacuum motor circuit in control unit is shorted. 	Cruise control and memory vehicle speed will be or are canceled. Cruise control resumes after power supply is turned ON using ignition or main switch.
Cancels erroneous vehicle speed	When vehicle speed is at least 10 km/h (6 MPH) greater than memory speed.	Cruise control is interrupted (built-in relay OFF.) It resumes (built-in relay ON) when vehicle speed is 8 km/h (5 MPH) less than memory speed.
Cancels abnormal output	When vacuum motor's output remains ON for at least 1 second, due to erroneous operation of control unit.	Cruise control is interrupted (built-in relay OFF). It resumes after ignition switch or main switch is turned OFF and then ON.
Cancels erroneous SET/COAST switch or RESUME/ACCEL switch operation	When SET/COAST switch or RESUME/ACCEL switch is ON before main switch is turned ON.	Cruise control activates after two switches are turned OFF.

4. PUMP AND VALVE

Pump activated by a signal emitted from control unit produces vacuum pressure to operate actuator.

1) During acceleration

A signal emitted from control unit energizes solenoid to close valve A. This causes motor to move diaphragm in direction F so that valve C closes while valve D opens. As a result, Vacuum pressure applied to section E increases. With this increase in vacuum pressure, actuator moves control cable so that throttle valve opens.

2) During deceleration

A signal emitted from control unit energizes solenoid to open valve A. This causes section E to open to the atmosphere so that actuator moves control cable so that throttle valve closes. The above operation of throttle valve is repeated during acceleration and deceleration so that vacuum produced at section E is controlled to meet vehicle speed.

Signal from control unit and valve operation.

		Safety valve	Vacuum motor	Vent valve
System OFF		Open	Stop	Open
System ON	Memory < actual car speed	Close	Stop	Open
	Memory = actual car speed	Close	Stop	Close
	Memory > actual car speed	Close	Rotate	Close

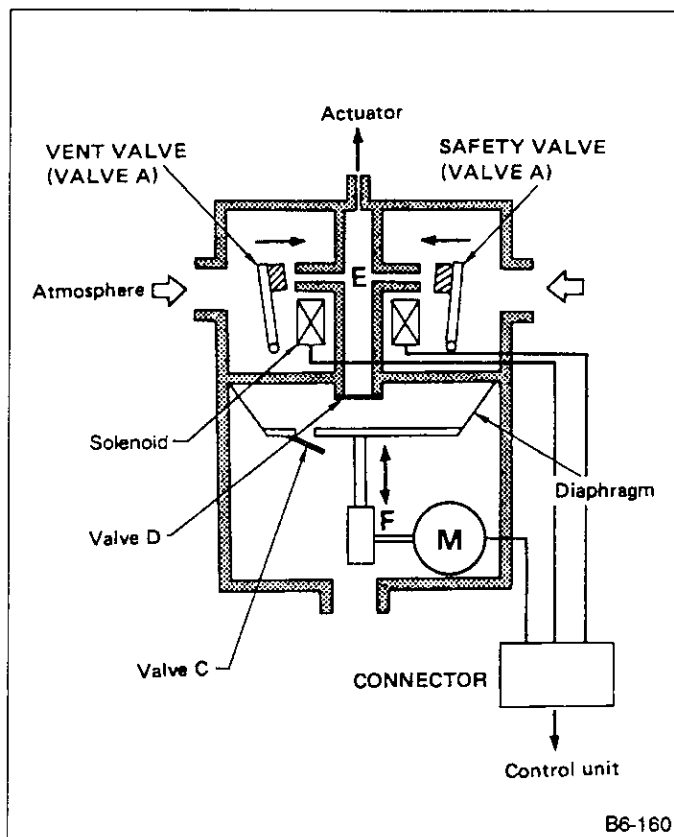


Fig. 142

5. ACTUATOR

The diaphragm is operated by vacuum or atmospheric pressure led by each valve, and this diaphragm movement actuates the wire cable via link ASSY to open or close the throttle valve. With the cruise control set to OFF (system OFF state), no diaphragm operation occurs as the atmospheric pressure is kept inside the actuator.

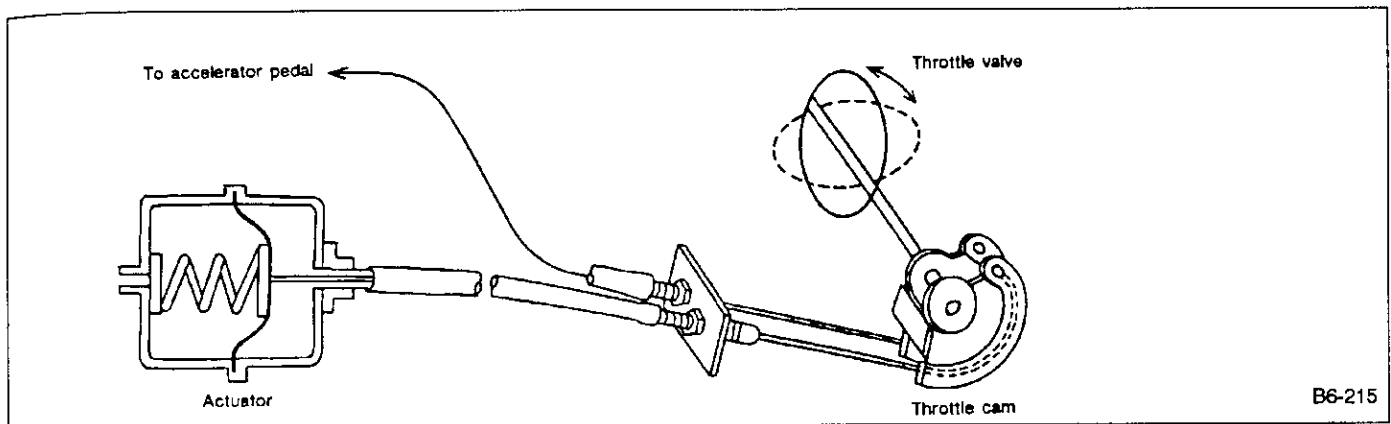


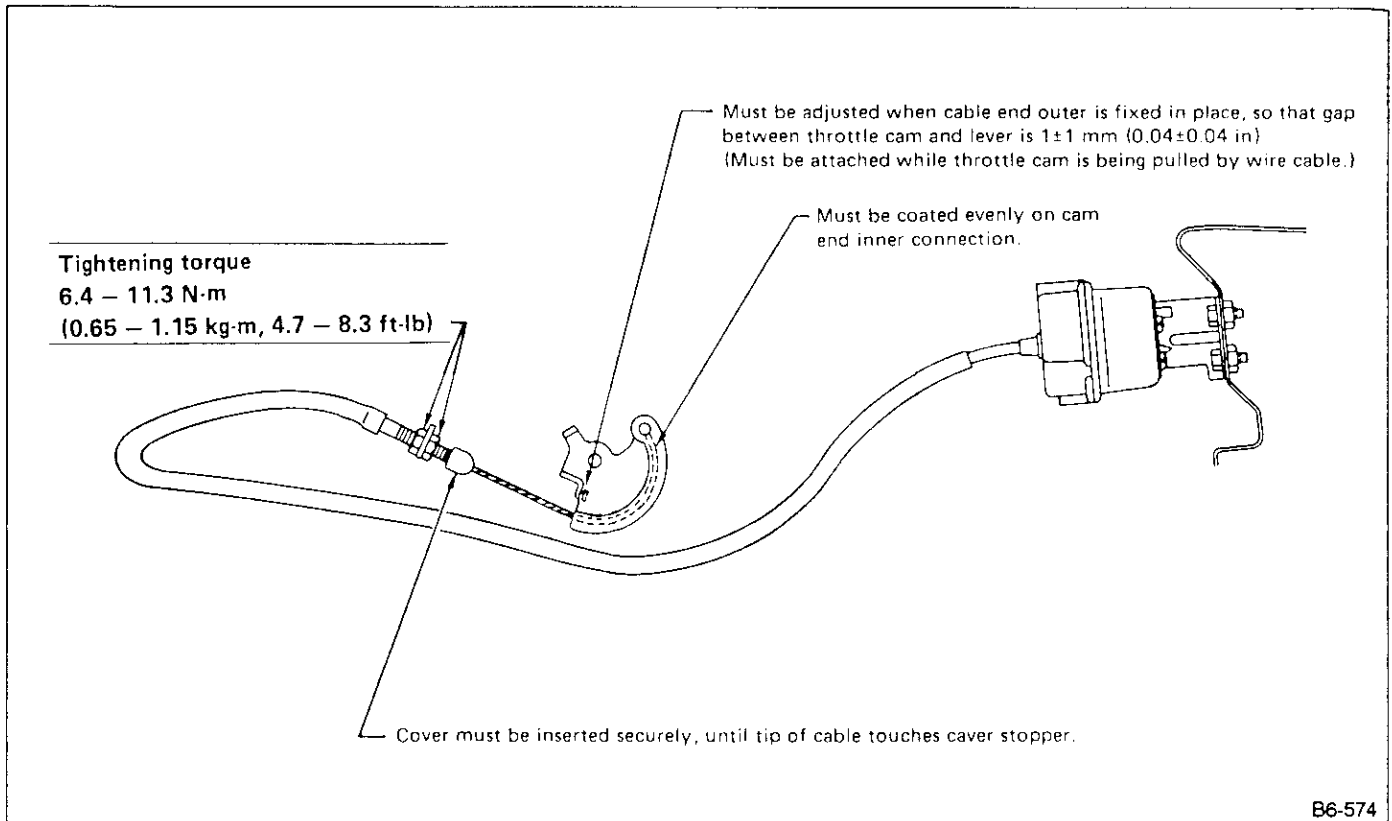
Fig. 143

6. ENGINE THROTTLE

The throttle body is equipped with two throttle cams. One cam is used during acceleration and the other during cruising, in order to open or close the throttle valve. These cams operate independently of each other. In other words, while one cam is operating, the other does not.

C: ADJUSTMENT

- a. Adjust accelerator pedal when the pedal is held in the fully returned position.
- b. Be careful not to apply excessive load to the wire cable when adjusting and/or installing; otherwise, the actuator may be deformed or damaged.



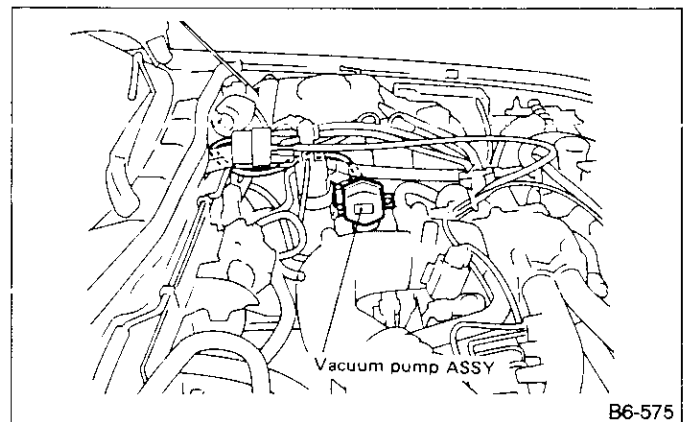
B6-574

Fig. 144

D: REMOVAL AND INSTALLATION

1. VACUUM PUMP

- 1) Disconnect wiring harness connector and hose.
Always disconnect hose at body pipe side.
 - 2) Remove attaching nuts and remove vacuum pump ASSY.
- Be sure to connect hose and wiring harness connector during installation.**



B6-575

Fig. 145

Tightening torque:

5.4 — 9.3 N·m
(55 — 95 kg-cm, 48 — 82 in-lb)

2. ACTUATOR

- 1) Remove intake manifold cover. Remove the nut which secures control cable end to throttle cam, and remove throttle cam.
- 2) Remove attaching bolts and actuator ASSY.
- 3) Remove clip bands from control cable. Disconnect vacuum pipe and vacuum hose.

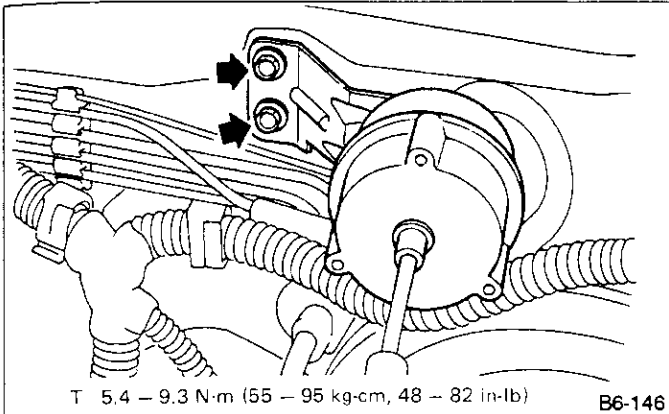


Fig. 146

- a. Install cable with clip opening in correct direction. (Reversed installation disables disassembly.)
- b. Apply grease to inner cable end.

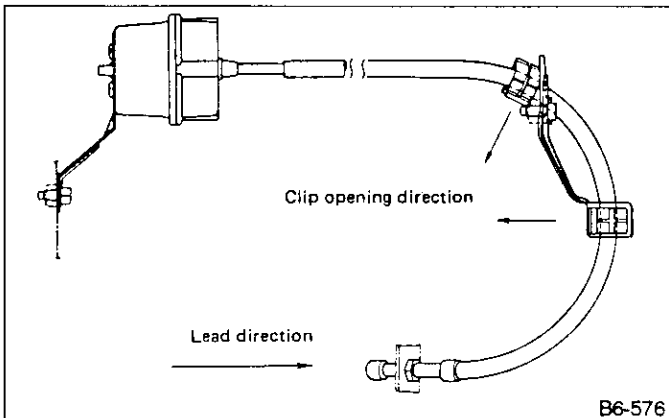


Fig. 147

3. STOP AND BRAKE SWITCH

(Ref. to [4-5].)

4. CLUTCH SWITCH

(Ref. to [4-5].)

5. CRUISE CONTROL MAIN SWITCH

- 1) Using a small screwdriver, remove cruise control main switch from instrument panel.

Be careful not to scratch instrument panel during removal.

- 2) Disconnect connector.

6. CRUISE CONTROL SUB SWITCH

- 1) Remove horn pad. (Ref. to [6-2])
- 2) Disconnect horn switch connector and remove attaching screws.

E: DRIVING TESTS

Conduct road tests by selecting a smooth, flat road or use free rollers as road-test simulation.

1. MAIN SWITCH

- 1) Turn ignition switch ON.
- 2) Check that indicator light comes on when main switch is pressed (ON).
- 3) Check that indicator light goes out when main switch is pressed again (OFF).
- 4) Turn ignition switch OFF with main switch ON (which is indicated by illumination). Turn ignition switch ON again to ensure that indicator light remains off.

2. SUB SWITCH

- 1) Check that sub switch is properly set in "SET/COAST" or "RESUME/ACCEL" mode.
- 2) Also check that sub switch returns to the original position when released.

3. CONSTANT-SPEED TEST

- 1) Turn main switch ON.
- 2) Drive vehicle at speed greater than 40 km/h (25 MPH).
- 3) Press sub switch to set in "SET/COAST" mode.
- 4) Ensure that vehicle is maintained at the speed set when sub switch was pressed.

4. ACCELERATION TEST

- 1) Set vehicle speed at speed greater than 40 km/h (25 MPH).
- 2) Ensure that vehicle continues to accelerate while holding sub switch in RESUME/ACCEL mode, and that vehicle maintains that optional speed when subswitch is released.

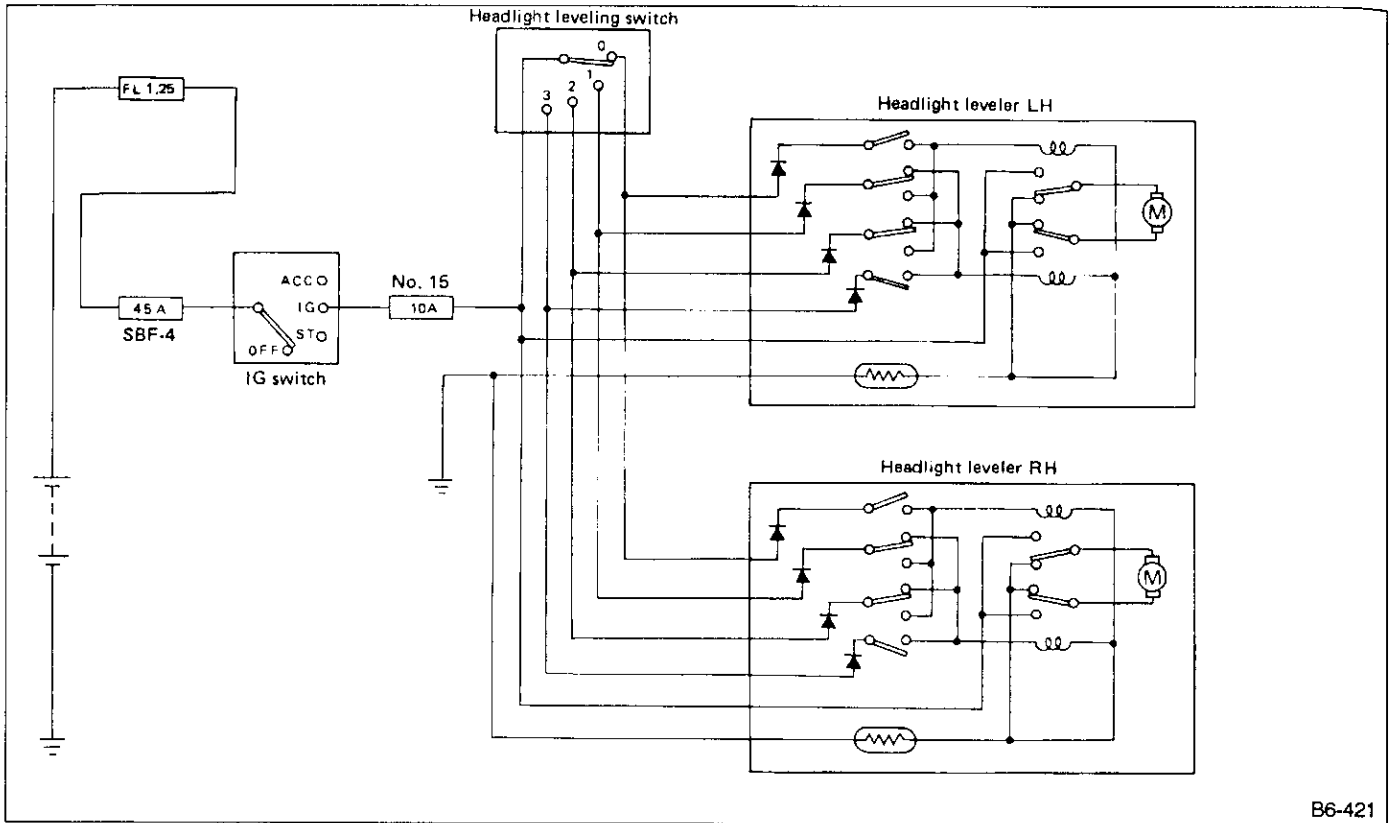
5. DECELERATION TEST

- 1) Set vehicle speed at optional speed greater than 40 km/h (25 MPH).
- 2) Ensure that vehicle continues to decelerate while holding sub switch in SET/COAST mode, and that it maintains that optional speed when subswitch is released.

When vehicle speed reaches the lower speed limit of 30 km/h (19 MPH) during deceleration, cruise control will be released.

33. Headlight Beam Leveler

A: SCHEMATIC



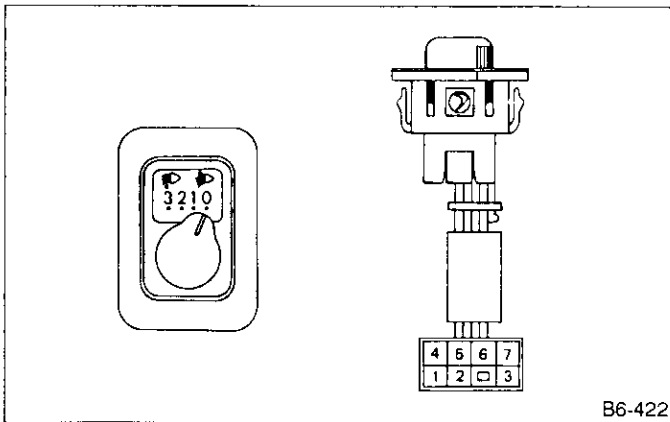
B6-421

Fig. 148

B: INSPECTION

Set switch to each position and check continuity between terminals (indicated in table below).

1. HEADLIGHT BEAM LEVELER



B6-422

Fig. 149

	1	2	3	4	7	5		6
0			○—○					
1		○—○						
2	○—○					○—○		
3				○—○				

T TROUBLESHOOTING (For Cruise Control)

1. Self Diagnosis

1. GENERAL

The self-diagnosis function of the cruise control system uses an external select monitor. The self-diagnosis function operates in two categories — the cruise cancel conditions diagnosis and real-time diagnosis, which are used depending on the type of problems.

Applicable cartridge No.: 498347600

- Cruise cancel conditions diagnosis

This category of diagnosis requires actual vehicle driving in order to determine the cause, (as when cruise speed is canceled during driving although no cruise cancel condition is not entered).



Cruise control unit memory stores the last "cancel" condition which occurred during driving. The code number corresponding with the last cruise "cancel" may be shown on the select monitor display.

- a. The cruise control memory stores not only the last cruise "cancel" which occurred (although "cancel" operation is not entered by the driver), but also the "cancel" condition input by the driver.
- b. The last cruise "cancel" only is stored in the select monitor memory.
- c. The content of memory is cleared when ignition switch or cruise main switch is turned OFF.

- Real-time diagnosis

The real-time diagnosis function is used to determine whether or not the input of output signal system is in good order, according to signal emitted from switches, sensors, etc.

Vehicle cannot be driven at cruise speed because problems occurs in the cruise control system or its associated circuits.



Dummy signals are manually entered from select monitor's keyboard, etc., to determine whether or not the vacuum pump motor circuit, etc. are in good order.

2. SELF-DIAGNOSIS PROCEDURES USING SELECT MONITOR

- 1) Connect select monitor to connector (B51) located behind lower instrument cover on driver's side.
- 2) Turn ignition switch ON, then turn cruise main switch ON.
- 3) Turn select monitor's power ON. All LED's will come on. Select monitor display will read, as shown below, after several seconds.

CRUISE (/)
YES:0, OTHERS:/

- 4) Pressing "0" will convert display to read:

CRUISE
RUN



CRUISE (F00)
CONTROL

If cruise main switch is OFF, error 2 will appear. Turn cruise main switch ON and repeat steps 2.

- 5) Press "F", "B", "0", and "ENT" in that order, and enter the desired designated code ("FB0", for example), or press scroll key to select the code.

3. DIAGNOSIS OF CRUISE CANCEL CONDITIONS

- 1) Connect select monitor.
- 2) Turn ignition and cruise main switch ON, and set select monitor in "FB0" mode.
- 3) Start engine and drive vehicle in 40 — 100 km/h speed range with cruise speed set.
- 4) If cruise speed is canceled itself (without doing any cancel operations), a trouble code will appear on select monitor display.

a. A trouble code will also appear when cruise cancel is effected by driver. Do not confuse.

b. Have a co-worker ride in vehicle to assist in diagnosis during driving.

- 5) Trouble code will be cleared by turning ignition or cruise main switch OFF.

Function code indication		Item to measure		Contents of diagnosis
Code No.	Abbreviation	Trouble code	Abbreviation	
FB0	CANCEL	10	OK	Normal
		11	BR/ST/CLorN	Input signals from brake switch, stop lamp switch, etc.
		12	E/G REV	Engine speed (rpm) limiter
		13	SPEED LIM	Low-speed control limiter
		14	SET+ RESUME	Simultaneous entry of two signals (Shorted circuit)
		21	MOTOR	Faulty motor or motor drive system
		22	VENT VALVE	Faulty vent valve and valve drive system
		23	C/U RELAY	Faulty relay built into cruise control unit
		24	SP SENSOR	Faulty vehicle speed sensor
		25	RESUME SW	Faulty resume switch

4. REAL-TIME DIAGNOSIS

1) Switch system diagnosis

- (1) Connect select monitor.
- (2) Turn ignition switch and cruise main switch ON.
- (3) Set select monitor in FA0 mode.
- (4) Ensure that normal indication is displayed when controls are operated as indicated below:

- When SET/COAST switch is pressed.
- WHEN RESUME/ACCEL switch is pressed.
- When brake pedal is depressed. (Brake switch & stop lamp switch turns ON.)
- When clutch pedal is depressed (MT model)
- When select lever is set to "N" (AT model).

LED's come on shortly after switches are pressed.

Function code indication		Item to measure	Contents of items to be monitored
Code No.	Abbreviation		
FA0	1. SE	SET/COAST switch	LED 1 comes on when switch is turned ON.
	2. RE	RESUME/ACCEL switch	LED 2 comes on when switch is turned ON.
	4. ST	Stop light switch	LED 3 comes on when switch is turned ON (brake pedal is depressed).
	5. BR	Brake switch and clutch switch/inhibitor switch	<ul style="list-style-type: none"> ● Brake switch [Set select lever (AT model) to any position other than "P" or "N"/depress clutch pedal (MT model)]. LED 4 comes on when brake pedal is depressed. ● LED 4 comes on when clutch pedal is depressed (MT model). ● LED 4 comes on when select lever is set to "P" or "N" (AT model).

2) Output system diagnosis

- (1) Connect select monitor.
 - (2) Turn ignition switch and cruise main switch ON (with engine OFF).
 - (3) Set select lever in "D" range (AT model). Do not depress clutch pedal (MT model).
 - (4) Set select monitor in FB1 mode. The display will read as shown below, until input OK (which indicates no problems) is present.
- However, you can change this display to another mode as desired.

OUT PUT ready?	(FB1) Yes:0
-------------------	----------------

- (5) After ensuring that select lever is set to "P" or "N" range (AT model) or clutch pedal is released (MT model), press "0".

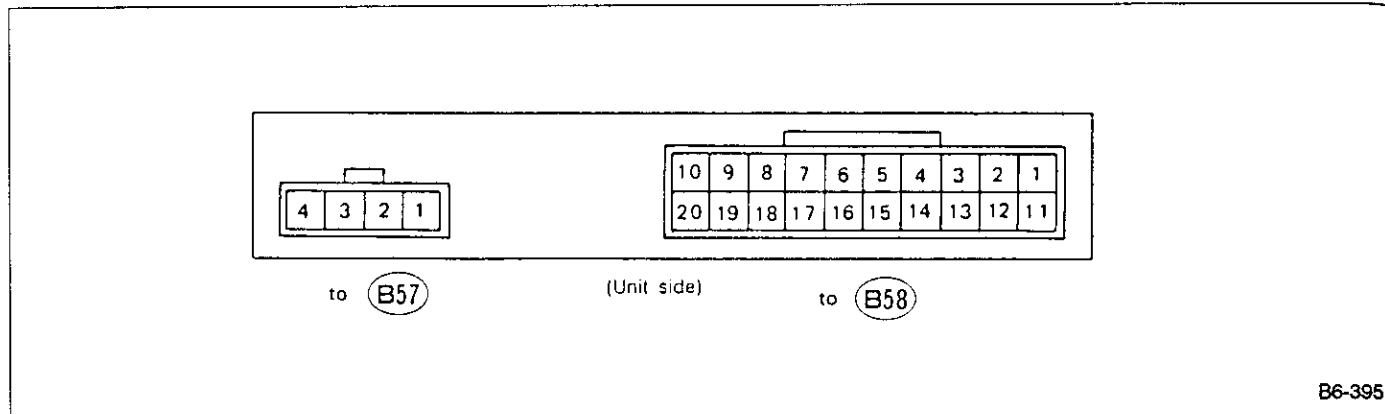
For example, pressing "0" in "N" range shows "31 MOTOR" (which indicates a faulty motor) on display because power supply to vacuum pump motor is disconnected. When this is shown, set select lever to "D" range (AT model) and turn cruise main switch OFF. Then start all over again after main switch is turned ON again.

Function code indication		Item to measure		Contents of diagnosis
Code No.	Abbreviation	Trouble code	Abbreviation	
FB1	OUTPUT	10	OK	Normal
		31	MOTOR	Open or shorted vacuum pump motor circuit/harness
		32	VENT VALVE	Open or shorted vent valve circuit/harness
		33	C/U RELAY	Deposited safety relay built into cruise control unit
		34	C/U VENT V	Faulty vent valve drive circuit of cruise control unit
		35	C/U MOTOR	Faulty vacuum pump motor drive circuit

5. DATA SHOWN ON SELECT MONITOR DISPLAY

Indication of function code		Item to measure	Contents of items to be monitored
Code No.	Abbreviation		
F 00	CRUISE CONTROL	Cruise control unit identification	Reads ROM ID number of cruise control unit to display a possible communication state.
F 01	VSP (MPH)	Vehicle speed (MPH)	Displays vehicle speed data (in miles/h) determined by cruise control unit in relation to signal emitted from vehicle speed sensor in combination meter.
F 02	VSP (km/h)	Vehicle speed (km/h)	Displays vehicle speed in km/h.
F 03	EREV (rpm)	Engine speed	Displays engine rpm determined by cruise speed control unit in relation to reference signal emitted from crank angle sensor.

2. I/O Signal of Cruise Control Unit



B6-395

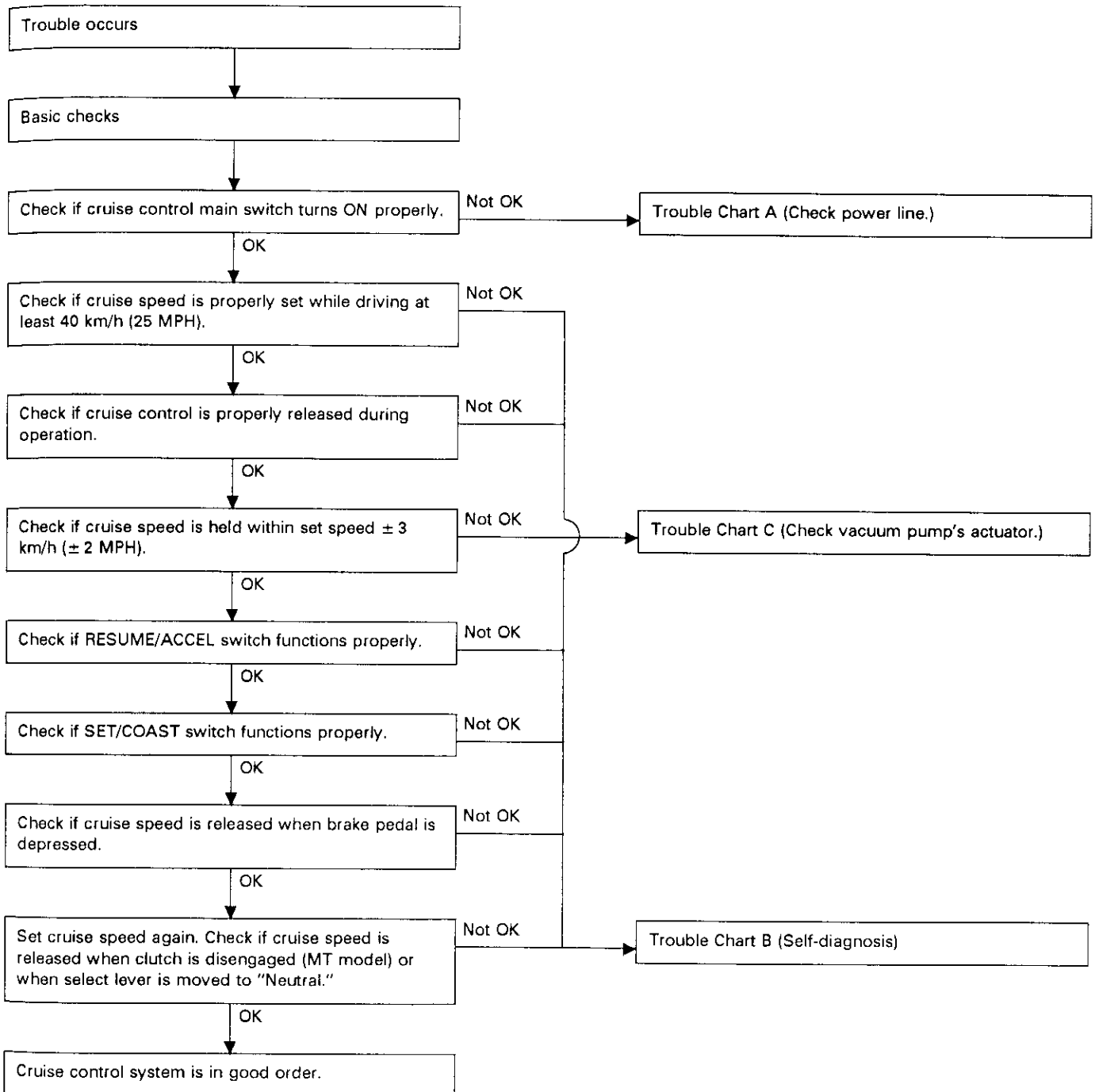
Fig. 150

Content	Connector No.	Terminal No.	Measuring conditions and I/O signals (ignition switch ON and engine idling)
Main switch	B57	1	<ul style="list-style-type: none"> When main switch is pressed, battery voltage is present; when it is released, approximately 6.5 volts are present. When main switch is OFF, "0" volts are present.
Main relay (solenoid)		2	<ul style="list-style-type: none"> When main switch is turned ON, indicator comes on and battery voltage is present. When main switch is turned OFF, "0" volts are present.
Main relay (contacts)		4	↑
Engine speed (rpm) signal	B58	2	When engine starts, a pulse signal is entered (Observe using an oscilloscope.)
Vehicle speed sensor		7	When all four wheels are raised off ground and any wheel is rotated manually, approximately 5 and 0 volt pulse signals are alternately sent to cruise control unit.
Brake switch		15	Set select lever to any position other than "P" or "N" (AT model)/leave clutch released (MT model), with main switch ON. Then check that: <ul style="list-style-type: none"> 0 volts are present when brake pedal is depressed. Battery voltage is present when brake pedal is released, or 0 volts are present when clutch pedal is depressed (MT model). Battery voltage is present when clutch pedal is released (MT model). 0 volts are present when select lever is set to "P" or "N" (AT model). Battery voltage is present when select lever is in any position other than "P" or "N" (AT model).
Stop light switch		20	With ignition switch ON or OFF: <ul style="list-style-type: none"> Depress brake pedal to check that battery voltage is present. "0" volts are present with brake pedal released.
SET/COAST switch		18	<ul style="list-style-type: none"> When switch is turned ON, battery voltage is present. When switch is turned OFF, "0" volts are present.
RESUME/ACCEL switch		19	↑
Set signal		11	ECU emits a ground-level signal while driving vehicle at least 40 km/h (25 MPH) with SET switch ON.
Power supply to vacuum motor, vent valve and safety valve		14	<ul style="list-style-type: none"> "0" volts are present when vehicle is stopped. Battery voltage is present while cruise control system is operating.
Vacuum motor output		8	<ul style="list-style-type: none"> Power supply is ON when vehicle is stopped. ON-and-OFF (0 and 12 volts) operation is alternately repeated while cruise control is operating.
Vent valve output		9	↑

Voltage at terminals (11, 14, 8 and 9) cannot be checked unless vehicle is driving at cruising speed.

3. Basic Troubleshooting Procedure

A: BASIC TROUBLESHOOTING CHART



B: BASIC CHECKS

1. CHECK CABLE AND VACUUM HOSE

1) Cable installation

- Ensure that cruise control cable is attached to the left of accelerator cable (on accelerator pedal side).
- Ensure that accelerator cable throttle cam does not move when cruise control throttle cam is moved by hand.
- Ensure that throttle cam moves smoothly.

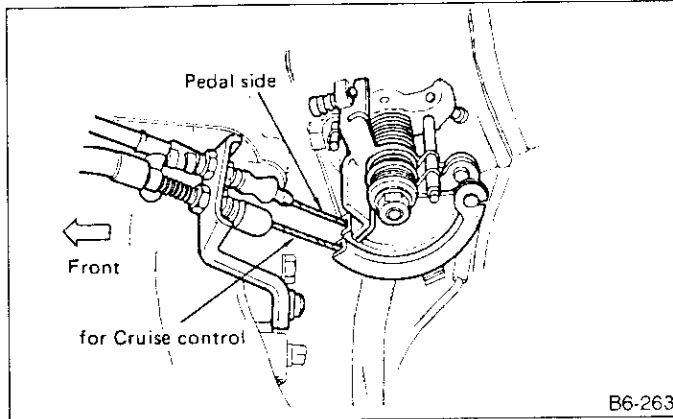


Fig. 151

2) Cable free play

- Ensure that throttle cam-to-lever clearance is within specifications.

Standard value: 1 mm (0.04 in)

If clearance is not within specifications, adjust cable at its outer end.

- Ensure that cap is positioned in groove.

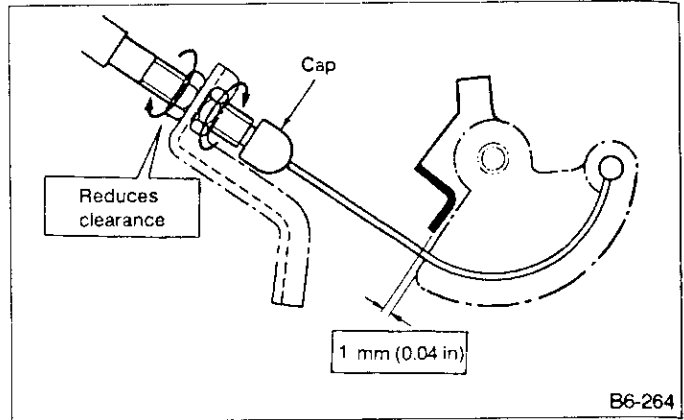


Fig. 152

3) Vacuum hose

Check vacuum hose (which connects vacuum pump and diaphragm) for disconnection or cracks.

2. CRUISE CONTROL UNIT CHECK

When a problem occurs in cruise control unit or its associated circuits, basic checks must first be conducted at the power supply, ground circuit, various terminal voltages, etc. Cruise control unit is not easily accessible for removal. In addition, a self-diagnosis function or a select monitor can be utilized, as required, to conduct "real-time" diagnosis or easily determine whether or not the cruise control unit is malfunctioning.

1) Cruise control unit removal

Cruise control unit can be extracted after glove box and right and lower sheet-metal frames of instrument panel are removed.

2) Disconnect cruise control unit connector. Use harness on body side to check cruise control unit condition.

3) Power supply check (ignition switch ON)

	Connector & terminal No.		Ignition switch ON
Main switch	(B57)	No. 1	Battery voltage is present when main switch is continuously pressed; 0 volts are present when main switch is released.
Main relay (solenoid)		No. 2	Battery voltage is present when main switch is continuously pressed; 0 volts are present when main switch is released.
Main relay (contacts)		No. 4	↑

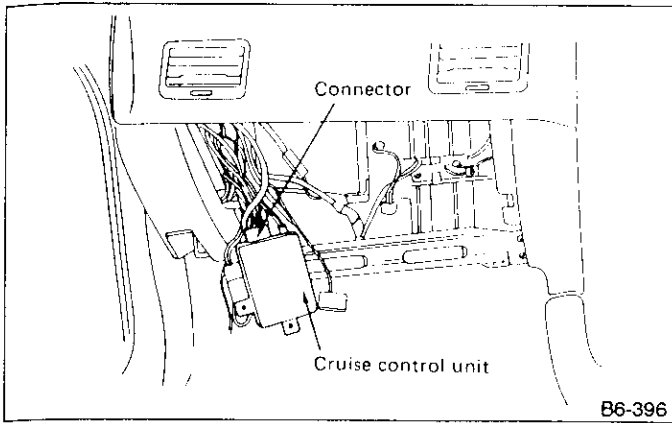


Fig. 153

4) Continuity check

Check continuity between terminals (indicated in table below).

Connector & Terminal / Specified resistance :
(B58) No. 10 — Body / 1 Ω max.

5) "Real-time" diagnosis

- When a problem is displayed as a result of "real-time" diagnosis, check its corresponding system or line. If no problems are displayed, the cruise control unit may be inoperative.
- "Real-time" diagnosis function is also used to directly locate malfunctioning relays built into cruise control unit.

<For reference>

Engine speed signal	(B58)	No. 2	A pulse signal is present when engine starts.
Vehicle speed sensor		No. 7	A pulse signal (approx. 0 — 5 volts) is present when all four wheels are raised off ground and one of them is rotated.
Brake switch		No. 15	Turn main switch ON. Move select lever to any position other than "P" or "N" (AT model) or release clutch pedal (MT model). Under this condition, 0 volts are present when brake pedal is depressed and battery voltage is present when brake pedal is released.
Stop light switch		No. 20	Battery voltage (Brake pedal depressed) 0 V (Brake pedal released)
SET/COAST switch		No. 18	Battery voltage (switch ON) 0 V (switch OFF)
RESUME/ACCEL switch		No. 19	Same as above

4. Trouble Chart A

Cruise control main switch fails to turn ON.

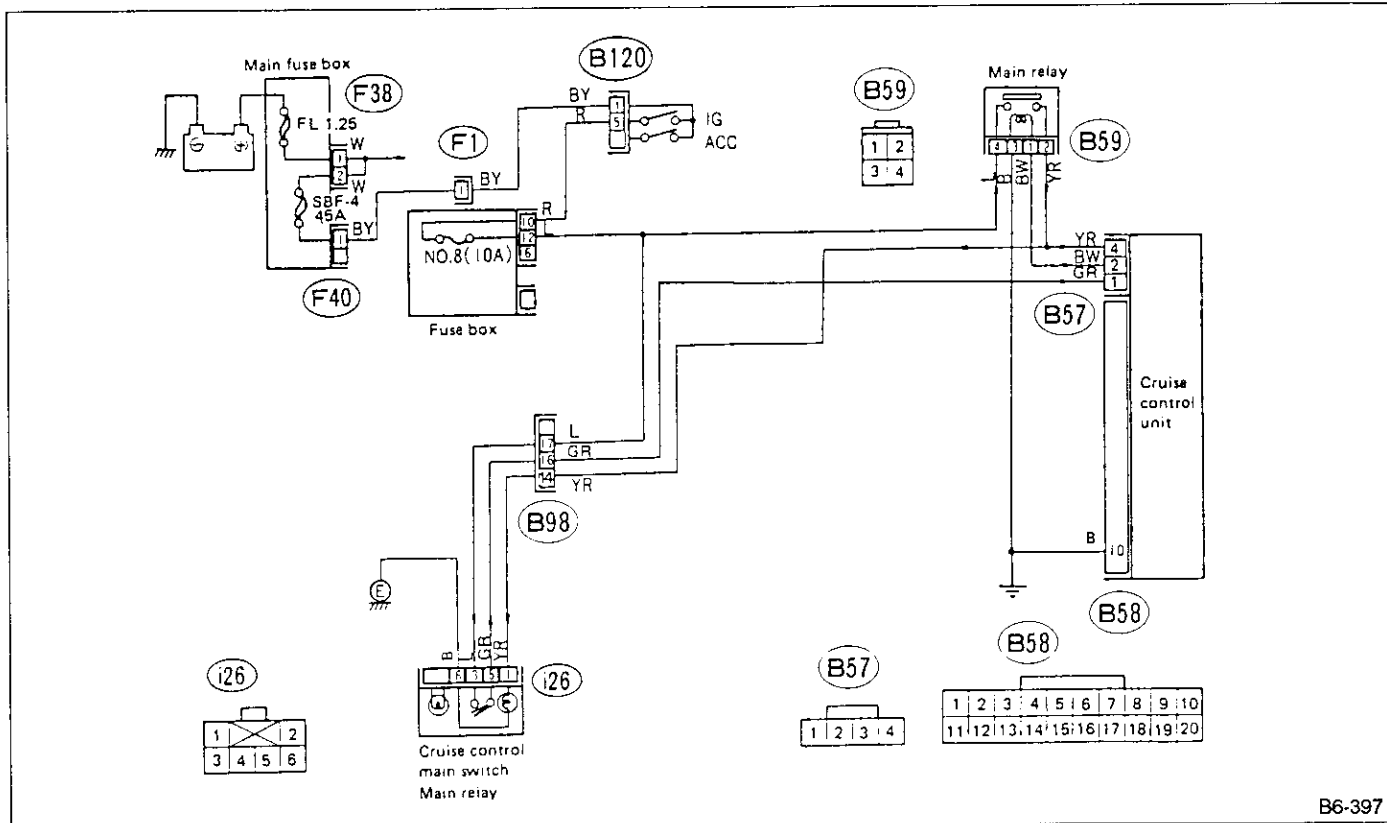
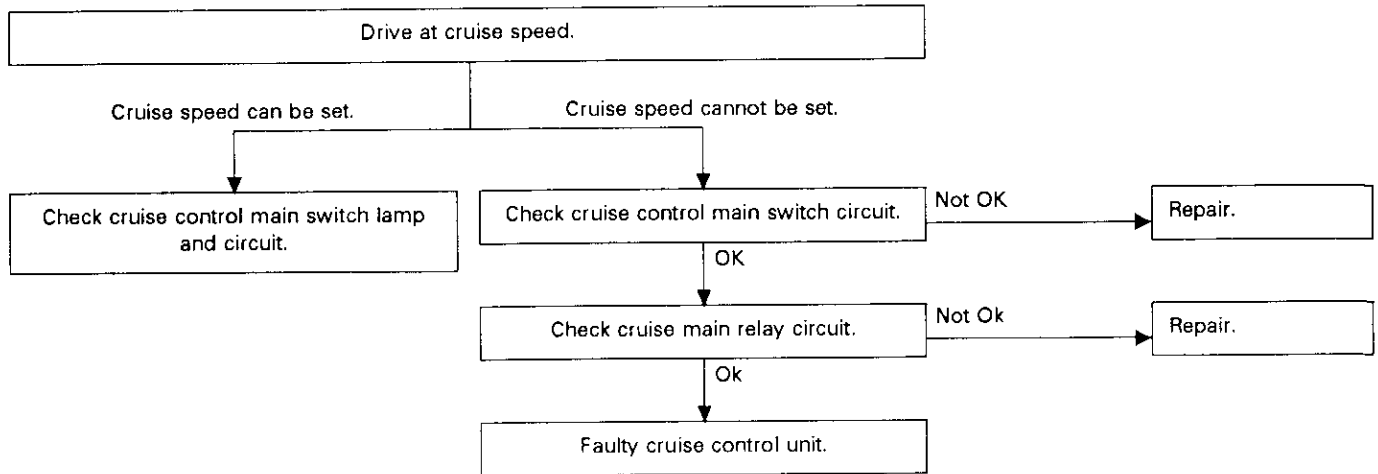


Fig. 154

B6-397

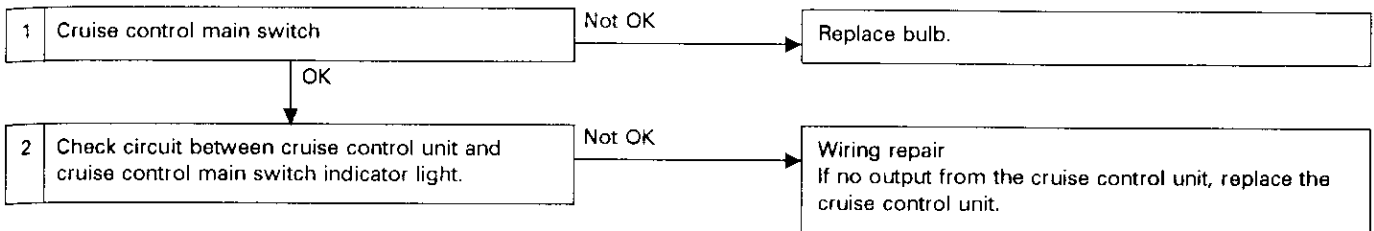
A: CHECK INDICATOR AND CIRCUIT IN CRUISE CONTROL MAIN SWITCH

CONTENT OF DIAGNOSIS:

Bulb failure or open harness of the indicator circuit in the cruise control main switch.

TROUBLE SYMPTOM:

Cruise control can be set normally indicator does not come on (when main switch is pressed).



1. CHECKING THE INDICATOR LAMP IN THE CRUISE CONTROL MAIN UNIT

- 1) Remove cruise main switch. Turn lower part of the housing upward to remove. If this cannot be done, insert a small screwdriver on the right hand side of the housing to remove the lock.
- 2) Measure resistance value between cruise control main switch terminals.

Terminal/Specified resistance:
No. 1 — No. 6/Approx. 120 Ω

2. CHECK CIRCUIT BETWEEN CRUISE CONTROL UNIT AND CRUISE CONTROL MAIN SWITCH INDICATOR LAMP

- 1) Cruise control unit and body
Measure voltage between cruise control main switch and body. (Perform this measurement by turning ON the ignition switch and the cruise control main switch.)

Connector & Terminal/Specified voltage:
(B57) No. 4 — Body/10 — 13 V
(i26) No. 1 — Body/10 — 13 V

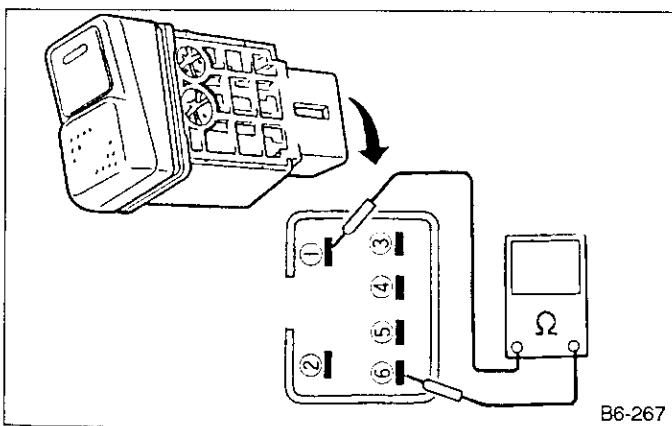


Fig. 155

- 2) Remove the connector from the cruise control main switch.
- 3) Measure the resistance value between the cruise control main switch and the body.

Connector & Terminal/Specified resistance:
(i26) No. 6 — Body/1 Ω max.

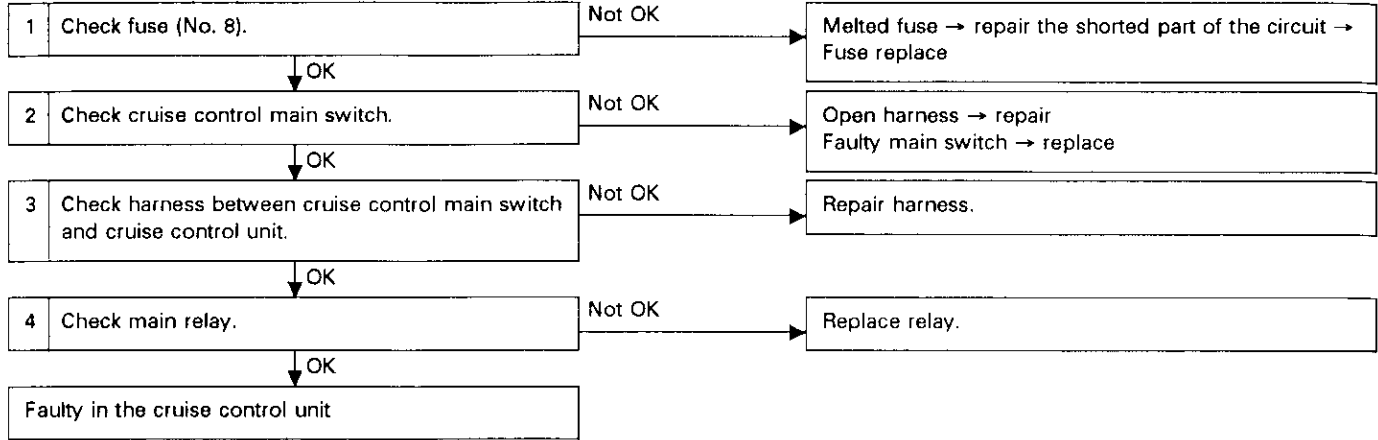
B: CHECK CRUISE CONTROL MAIN SWITCH AND MAIN RELAY

CONTENT OF DIAGNOSIS:

Faulty cruise control main switch or relay, or open harness.

TROUBLE SYMPTOM:

Cruise control main switch is not turned ON and cruise control cannot be set.



- If main relay operates, this circuit operates normally. Whether main relay is normal or not can be checked by operating sound. (When turning ON ignition switch and main switch, a click sound heard from glove box side is normal.)

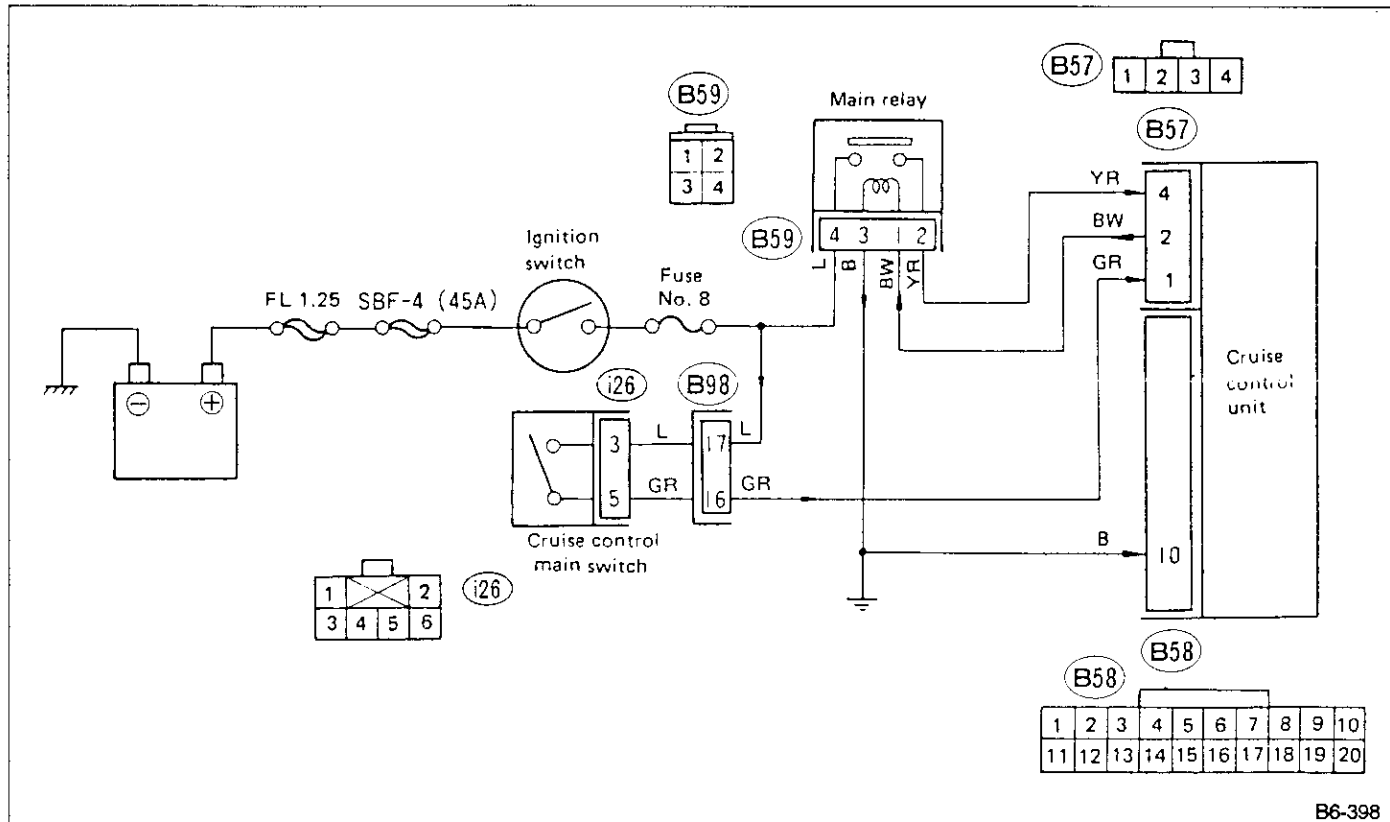


Fig. 156

B6-398

1. CHECK FUSE (No. 8).

- 1) Check fuse (No. 8).
Test circuit with a tester.
- 2) Check voltage of the ignition power source.
Turn ignition switch ON and measure the voltage between the fuse box connector and the body.

Connector & Terminal/Specified voltage:
(B104) No. 12 — Body/10 — 13 V

2. CHECK CRUISE CONTROL MAIN SWITCH.

- 1) Cruise control main switch
 - (1) Insert a small screwdriver into lower cut part of panel to remove. If removal cannot be done, insert a screwdriver into the center part on right hand side of panel to remove the lock.
 - (2) Turn ignition switch ON and measure the voltage between cruise control main switch connector and body.

Connector & Terminal/Specified voltage:
(i26) No. 3 — Body/10 — 13 V

- 2) Check ON/OFF function of main switch.
Measure resistance between main switch and terminal.

Terminal/Specified resistance:
No. 3 — No. 5/0 Ω (Switch ON)
1 M Ω min. (Switch OFF)

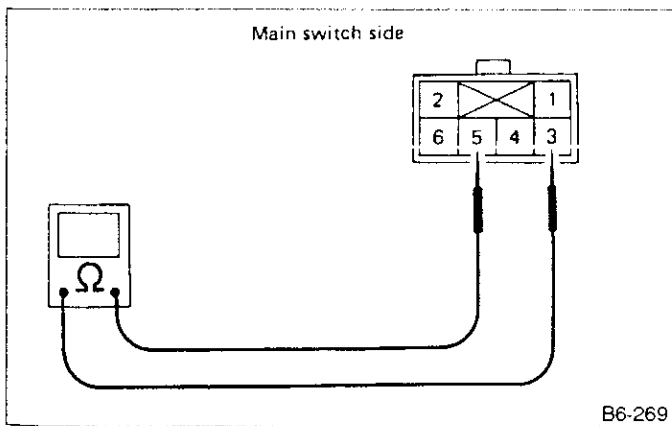


Fig. 157

3. CHECK HARNESS BETWEEN CRUISE CONTROL MAIN SWITCH AND THE CRUISE CONTROL UNIT.

To check whether harnesses are normal or not, measure voltage at each of the terminals as the distance between connectors is long.

- 1) Turn ignition switch ON.
- 2) Turn cruise main switch ON.
- 3) Measure voltage between each of terminals and body.

Connector & Terminal/Specified voltage:
(i26) No. 3 — Body/10 — 13 V
(i26) No. 5 — Body/10 — 13 V
(B57) No. 1 — Body/10 — 13 V

4. CHECK MAIN RELAY.

- 1) Turn ignition switch ON.
- 2) Check voltage at main relay power source. (Tighten main relay together the cruise control unit. Black connector)
Measure the voltage between the main relay and the body.

Connector & Terminal/Specified voltage:
(B59) No. 4 — Body/10 — 13 V

- 3) Check main relay operation.
Measure resistance between contact point side terminals when applying battery power to exciting coil side (No. 1-3).

• Whether relay is normal or not can be easily checked by relay operation sound. (When turning ignition switch and cruise control main switch ON, a click sound heard from left side of glove box is normal.)

Terminal/Specified resistance:
No. 2 — No. 4/0 Ω (with 12 V connection)
1 M Ω min. (without 12 V connection)

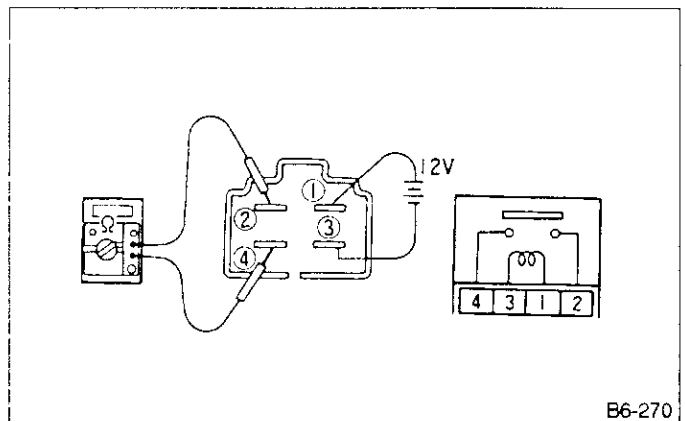
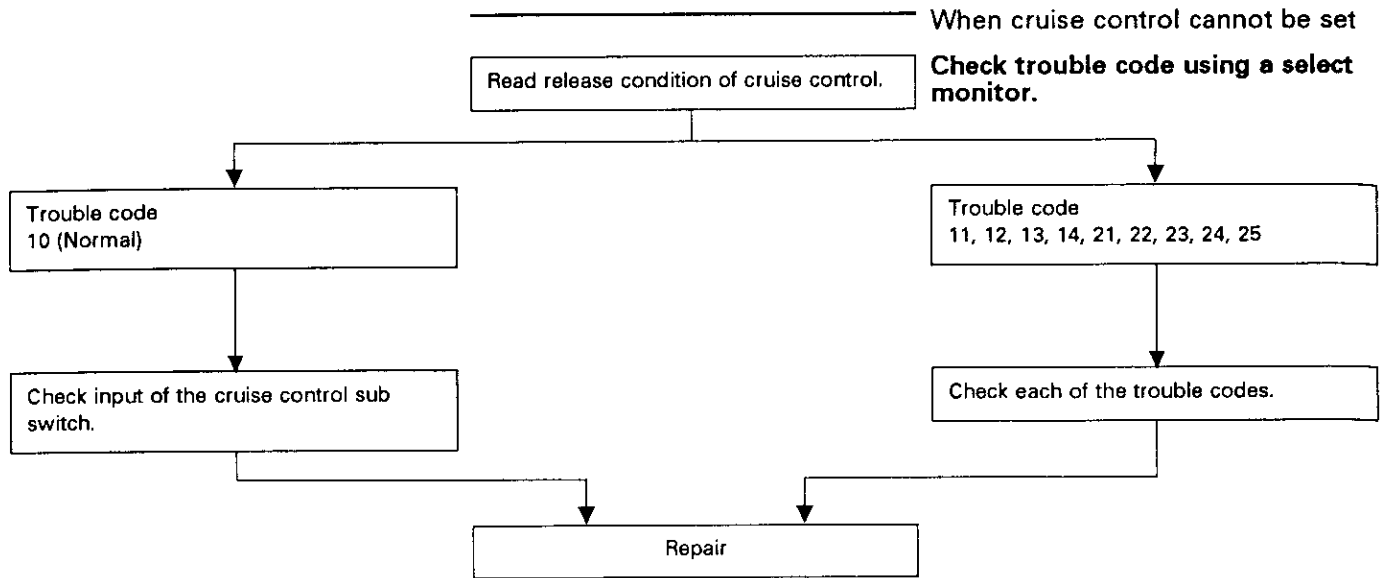


Fig. 158

5. Trouble Chart B

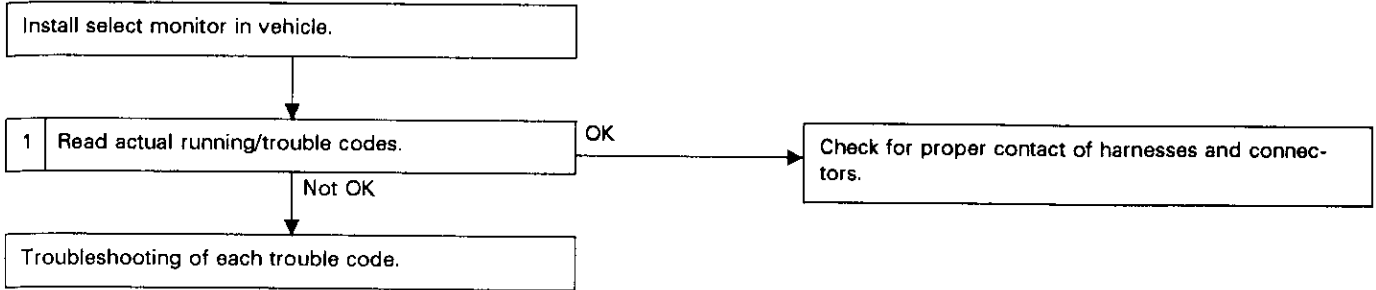


	Page
Check trouble code with a select monitor.	99
Checking input of cruise control sub switch. (SET/COAST SW, RESUME/ACCEL SW)	100
Trouble code 11. (Stop light switch, brake switch, inhibitor switch and clutch switch)	102
Trouble code 12. (Failure of engine revolution input signal)	104
Trouble code 13. and 24. Malfunction in the speed sensor system	106
Trouble code 14. (Simultaneously input signals of SET/COAST and RESUME/ACCEL SW	108
Trouble code 21. and 22. (Malfunction in cruise vacuum pump and vent valve)	110
Trouble code 23. Malfunction in built-in relay of cruise control unit	112

A: CHECK TROUBLE CODE WITH A SELECT MONITOR.

CONTENT OF DIAGNOSIS:
Read trouble code.

TROUBLE SYMPTOM:
● Cruise control cannot be set.
● Cruise control is occasionally released.



● By checking the trouble codes, it can be read through a self diagnosis, but it is effective to use a select monitor.

1. READ THE TROUBLE CODE.

● Measuring condition: continuous running until cruise control is released.

CANCEL (FB0)
11 BR/ST/CL or N

● Operation of the function keys: F B O ENT
● Indication: Always perform diagnosis while vehicle is running, and immediately indicate trouble code number when release condition occurs.

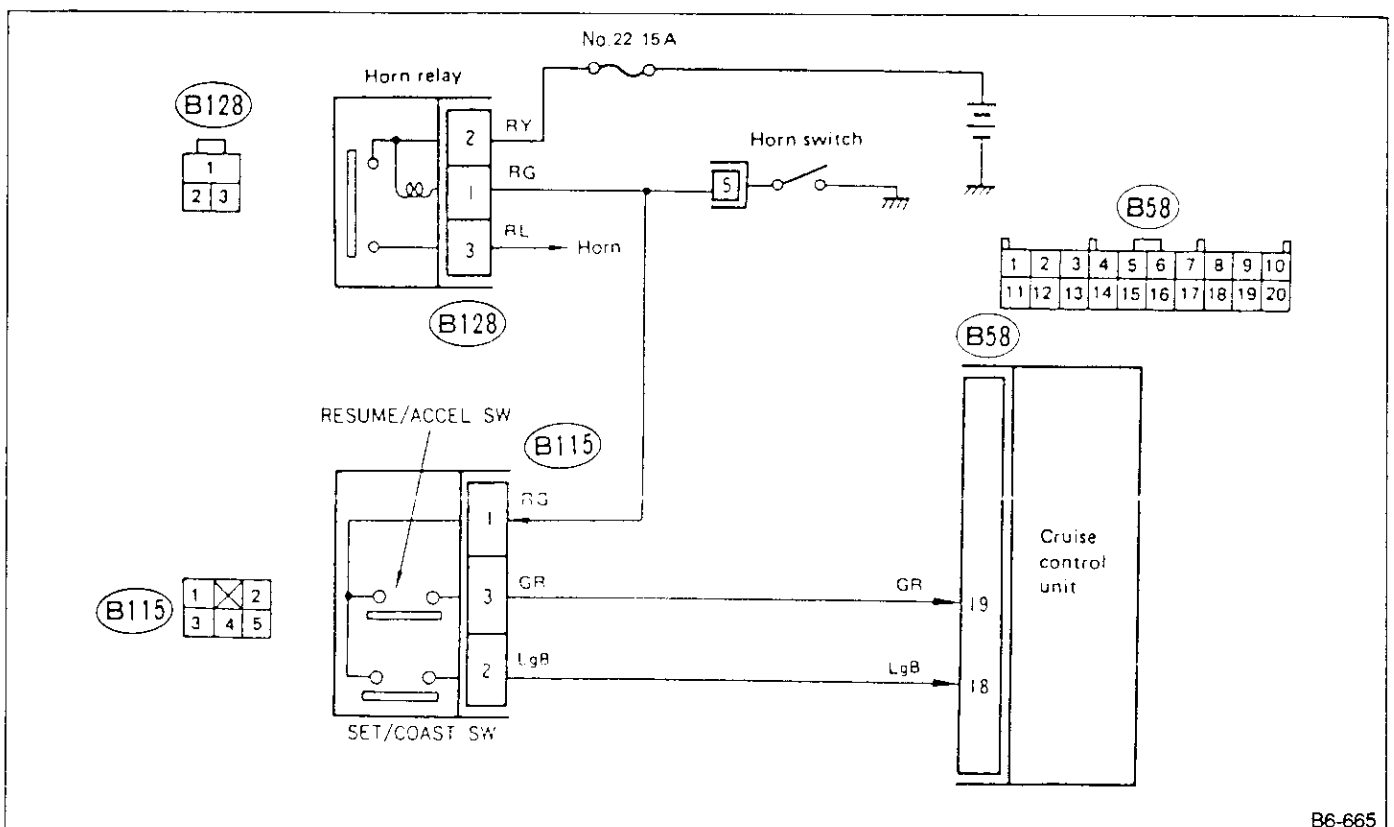
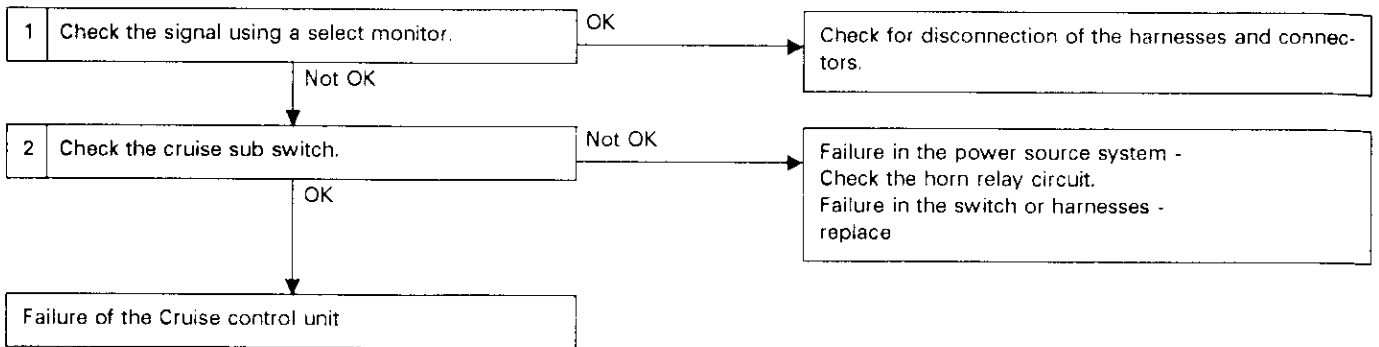
B: CHECKING INPUT OF CRUISE CONTROL SUB SWITCH

CONTENT OF DIAGNOSIS:

- SET/COAST SW or disconnection of the wiring or short circuit
- RESUME/ACCEL SW or disconnection of the wiring or short circuit

TROUBLE SYMPTOM:

- The cruise control cannot be set, or it is canceled immediately.
- RESUME/ACCEL cannot be operated.



B6-665

Fig. 159

1. CHECK WITH SELECT MONITOR.

● Measuring condition: Turn ON the ignition switch and cruise main switch.

Operation of the function keys: **F** **A** **O** **ENT**

When pushing the SET SW:

1 The LED goes out - lights

When pushing the RES SW:

2 The LED goes out - lights

2. CHECK CRUISE CONTROL SUB SWITCH

- 1) Remove horn cover. (Put your finger into slit of cover and pull up.)
- 2) Separate connector from sub switch. (Use together with horn power supply.)
- 3) Check voltage between sub switch connector and body.

Connector & Terminal/Specified voltage:
(B115) No. 1 — Body/10 — 13 V

- 4) Check for harness short circuit between SET/COAST SW, RESUME ACCEL/SW and cruise control unit.

Connector & Terminal/Specified resistance:
(B115) No. 2 — Body/1 MΩ min.
(B115) No. 3 — Body/1 MΩ min.

- 5) Check inner switch of the cruise control sub- switch. Check continuity at switch side connector.

Connector & Terminal:
(B115) No. 1 — 2 [SET/COAST SWITCH]
(B115) No. 1 — 3 [RESUME/ACCEL SWITCH]

Specified resistance:
0 Ω (Switch ON)
1 MΩ min. (Switch OFF)

C: TROUBLE CODE 11 — (STOP LIGHT SW, BRAKE SW, INHIBITOR SW AND CLUTCH SW)

CONTENT OF DIAGNOSIS:

- Failure or disconnection of the stop light switch and brake switch.
- Failure or disconnection (AT) of the inhibitor relay and inhibitor switch.
- Failure or disconnection of the clutch relay and clutch switch.

TROUBLE SYMPTOM:

The cruise control cannot be set.

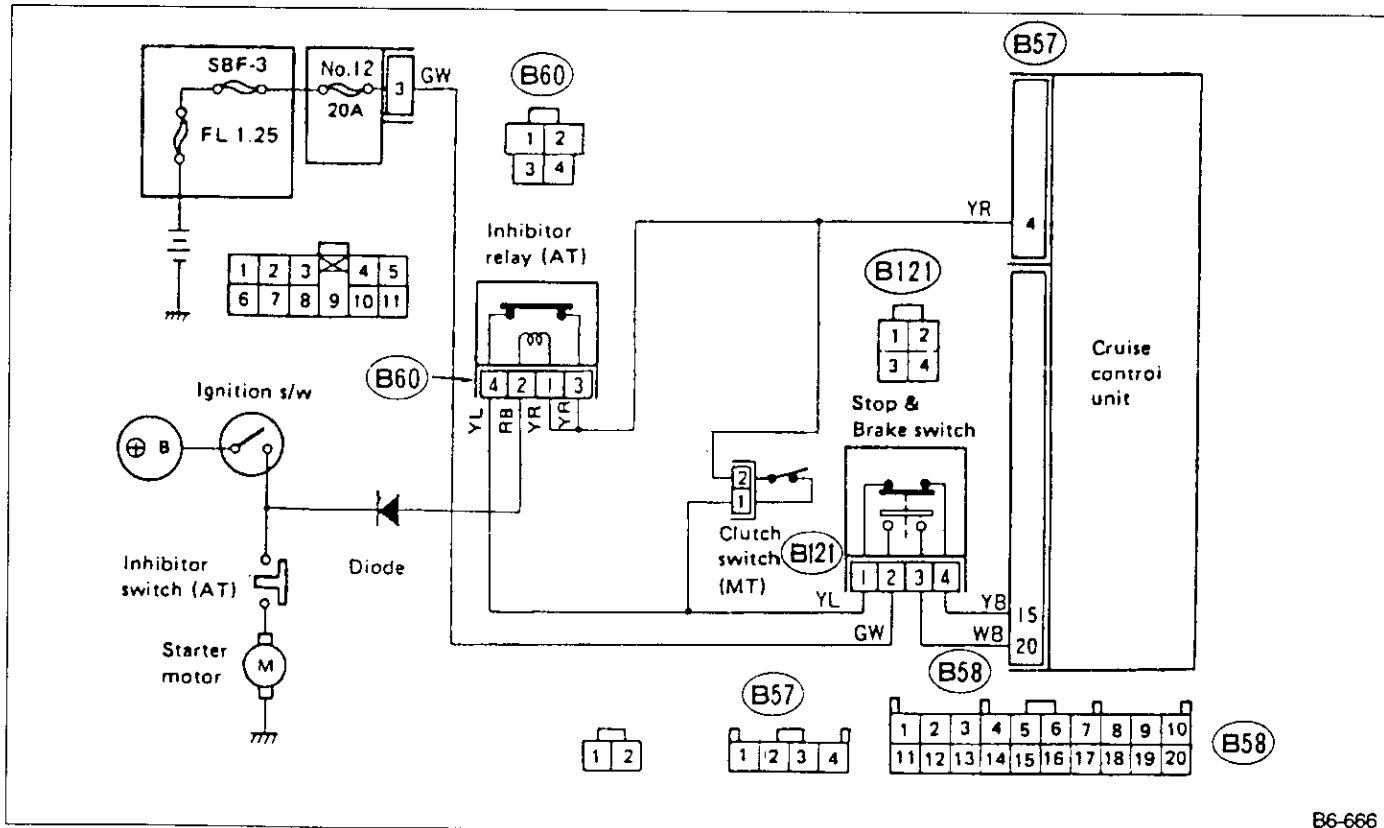
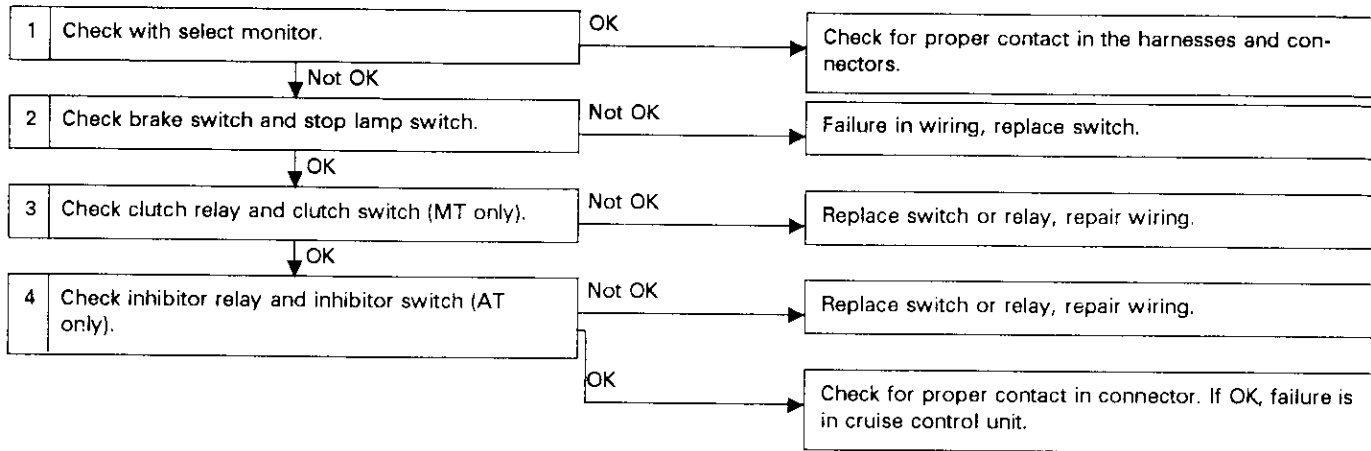


Fig. 160

1. CHECK WITH SELECT MONITOR.

- Measurement condition: Turn ignition switch ON.
Turn cruise main switch ON.
 - Operation of the function keys: **F** **A** **O** **ENT**
- 1) When depressing brake pedal (Set in the D range for AT, without depressing clutch pedal for MT)
Stop light switch:
 [4] LED goes out - lights.
 Brake switch:
 [5] LED goes out - lights.
 - 2) When depressing clutch pedal (Clutch relay signal)
 [5] LED goes out - lights.
 - 3) When setting shift lever in N position (Inhibitor relay signal)
 [5] LED goes out - lights.

2. CHECK BRAKE SWITCH AND STOP LIGHT SWITCH.

- 1) Remove connector of stop light switch.
- 2) Check circuit between each terminal while depressing brake pedal.

Pedal operation	Brake switch between No. 1-4	Stop light switch between No. 2-3
Depressing the brake pedal	Circuit failure	Circuit normal
Without depressing the brake pedal	Circuit normal	Circuit failure

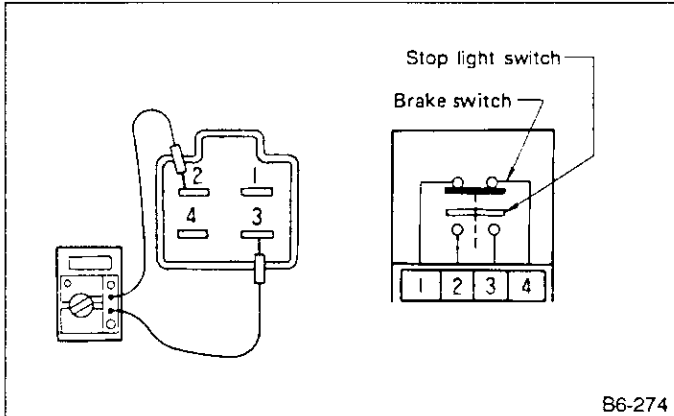


Fig. 161

B6-274

3. CHECK CLUTCH SWITCH (MT ONLY).

Check items for the clutch switch (Circuit test between terminals).

Specified resistance:
 0 Ω (Switch ON)
 1 MΩ min. (Switch OFF)

4. CHECK INHIBITOR RELAY AND INHIBITOR SWITCH (N RANGE) (AT ONLY).

- 1) Check inhibitor relay and inhibitor switch.
Turn ignition switch and cruise main switch ON when setting the shift lever to the N position. Operation sounds will be heard when relay contact points are separated.
- 2) Check inhibitor relay.
When applying 12 V power to terminals No. 1 to 2 of inhibitor relay.

Terminal/Specified resistance:
 No. 3 — No. 4/1 MΩ min.

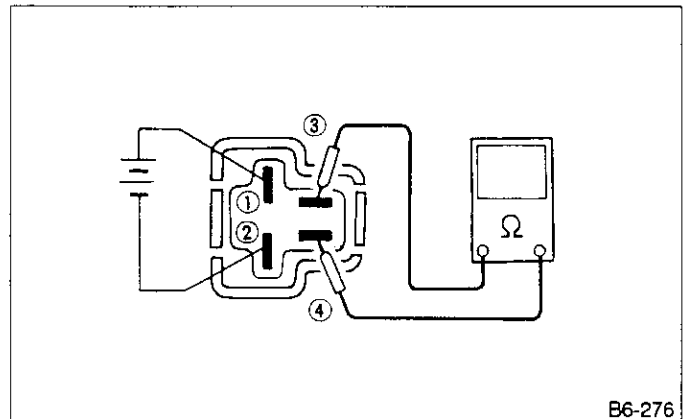


Fig. 162

B6-276

- 3) Item check for inhibitor switch
When engine starts in the N range (the starter rotates), N range contact point of the inhibitor is normal.
- 4) Check the wiring harnesses.

D: TROUBLE CODE 12 — (FAILURE OF ENGINE REVOLUTION INPUT SIGNAL)

CONTENT OF DIAGNOSIS:
 Short circuit of engine revolution input signal from MPFI control unit

TROUBLE SYMPTOM:
 Cruise control cannot be set. (Canceled immediately)

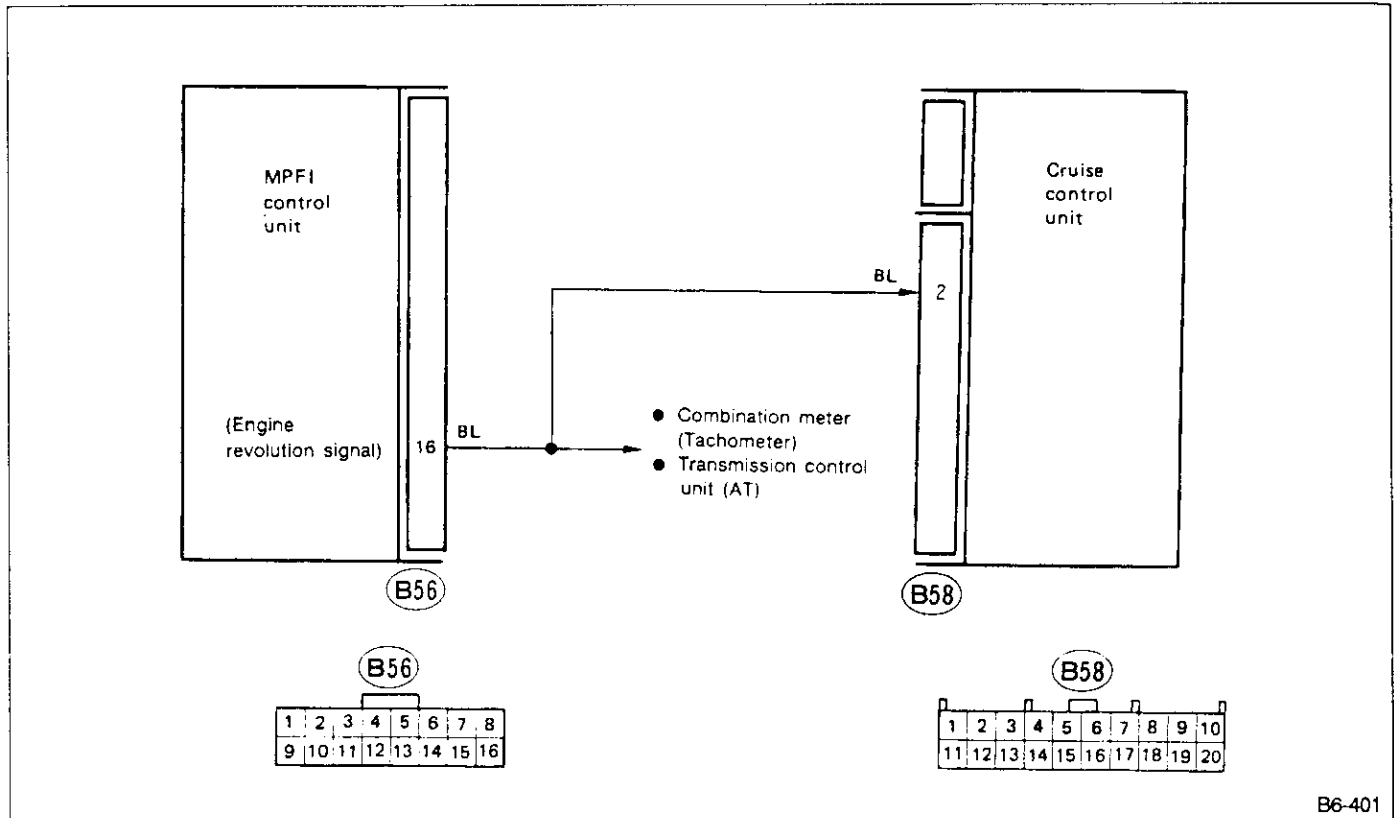
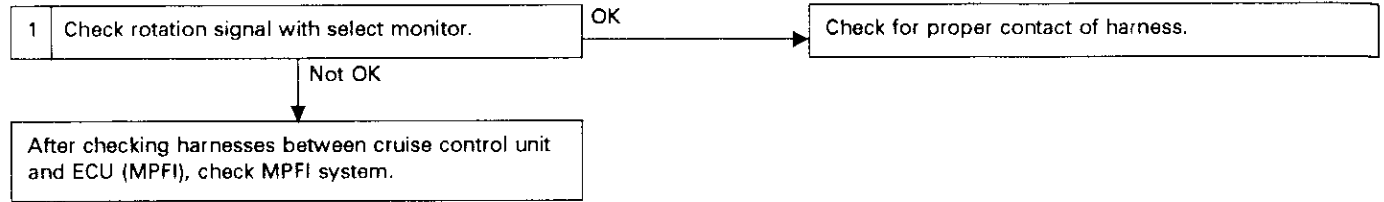


Fig. 163

B6-401

1. CHECK WITH SELECT MONITOR.

- Measurement condition: idling or 2000 rpm

EREV F03
2000 rpm

- Operation of function keys :

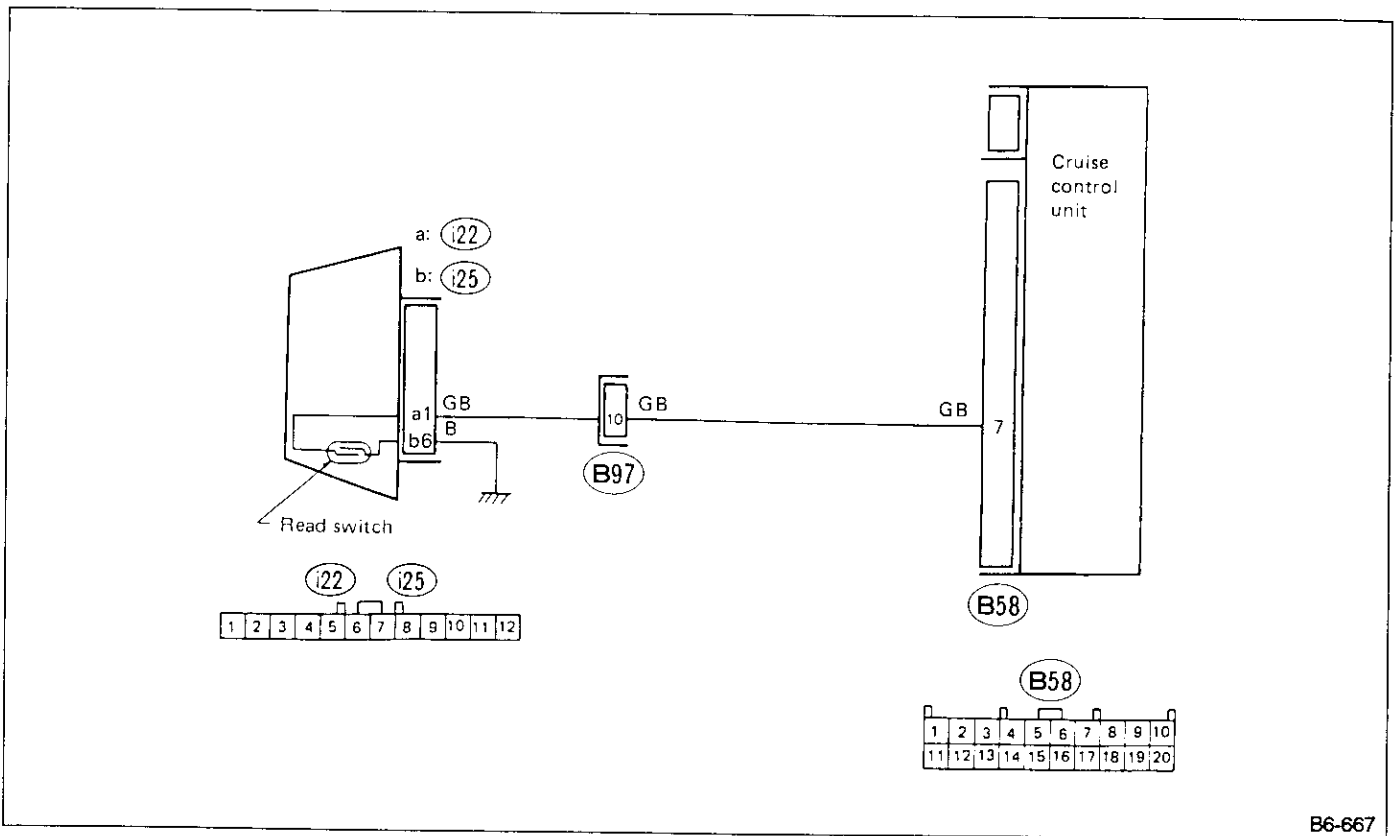
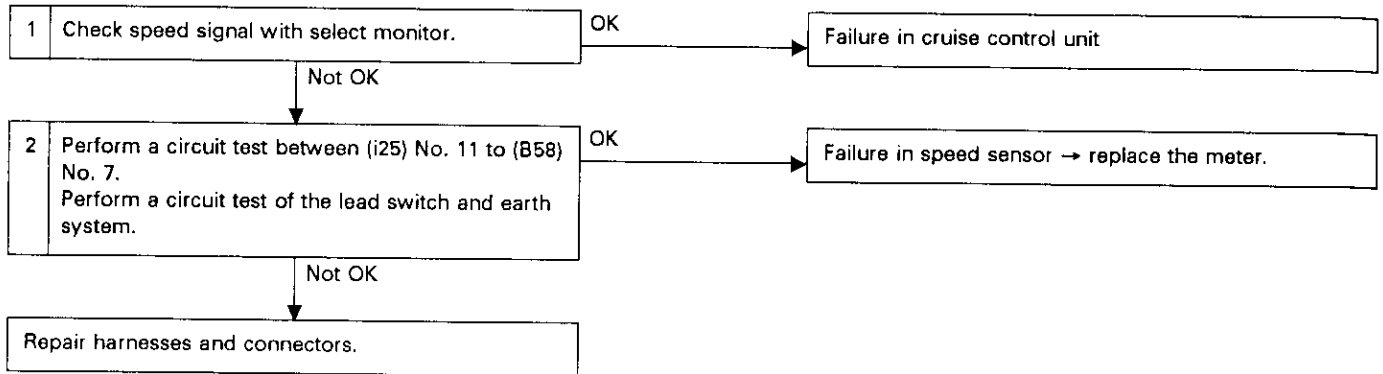
Standard value: ± 100 rpm

Reference: Indicated value for disconnection or short circuit: 0 — 1 km/h

E: TROUBLE CODE 13 AND 24 — MALFUNCTION IN SPEED SENSOR SYSTEM

CONTENT OF DIAGNOSIS:
 Disconnection or short circuit of speed sensor

TROUBLE SYMPTOM:
 Cruise control cannot be set. (Canceled immediately)



B6-667

Fig. 164

1. CHECK VEHICLE SPEED SIGNAL WITH SELECT MONITOR.

- Driving condition: Running at speed greater than 40 km/h (25 MPH)

VSP (F02) 90 km/h

- Operation of the function keys:

F	0	2	ENT
---	---	---	-----

Standard value: ± 16 km/h (± 10 MPH)

Reference:

- When there is a failure in the meter cable or the speed sensor, the indicated value of the meter will be incorrect.
- When there is a disconnection or short circuit in the harness between the meter and the cruise control unit, the indicated value will be 0 — 1 km/h.

2. CIRCUIT TEST FOR EACH HARNESSSES

- 1) Separate connectors from combination meter and cruise control unit.
- 2) Perform a circuit test in the harnesses.

Connector & Terminal/Specified resistance:
(i25) No. 11 — (B58) No. 7/1 Ω max.

F: TROUBLE CODE 14 — (SIMULTANEOUSLY INPUT SIGNALS OF SET/COAST AND RESUME/ACCEL SW)

CONTENT OF DIAGNOSIS:
Short circuit inside the SET/SW and RESUME SW

TROUBLE SYMPTOM:
 • Cruise control cannot be set.
 • Canceled immediately.

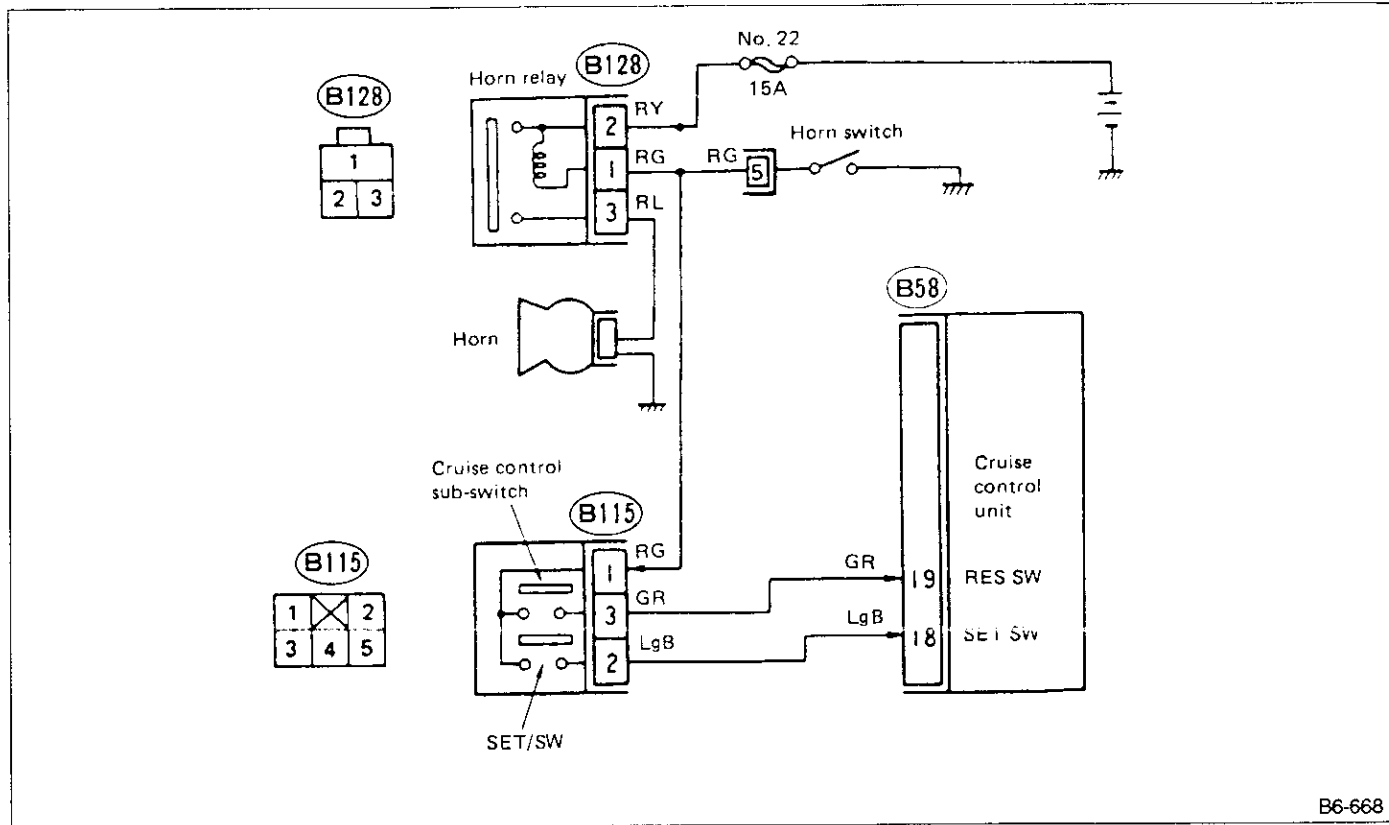
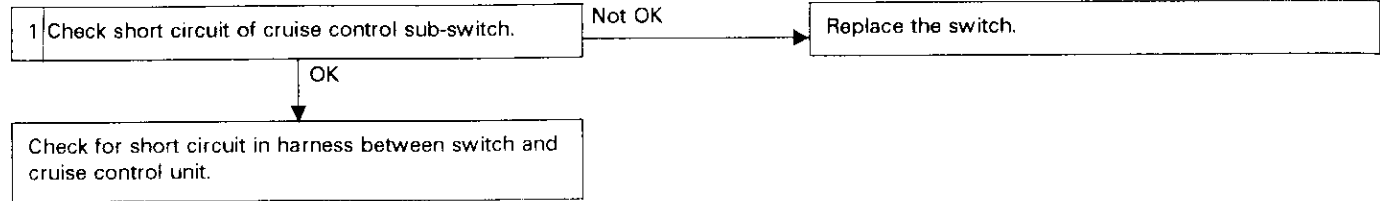


Fig. 165

B6-668

1. CHECK FOR SHORT CIRCUIT OF CRUISE CONTROL SUB SWITCH.

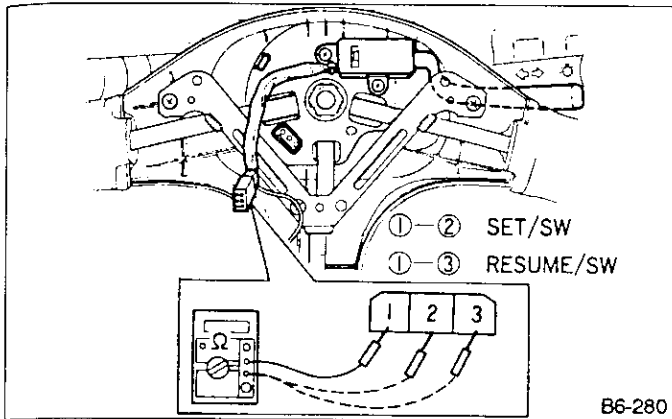


Fig. 166

- 1) Separate connector of cruise control sub switch.
- 2) Perform a circuit test between each of terminals while pushing the SET/SW.

Measure resistance between each terminal of cruise control sub switch.

Terminal/Specified resistance:

No. 1 — No. 2/0 Ω (SET switch ON)

No. 1 — No. 3/0 Ω (RESUME switch ON)

G: TROUBLE CODE 21 AND 22 — (MALFUNCTION IN CRUISE VACUUM PUMP AND VENT VALVE)

CONTENT OF DIAGNOSIS:
Open or poor contact of the vacuum pump motor and vent valve

TROUBLE SYMPTOM:
Cruise control cannot be set. (Or canceled immediately)

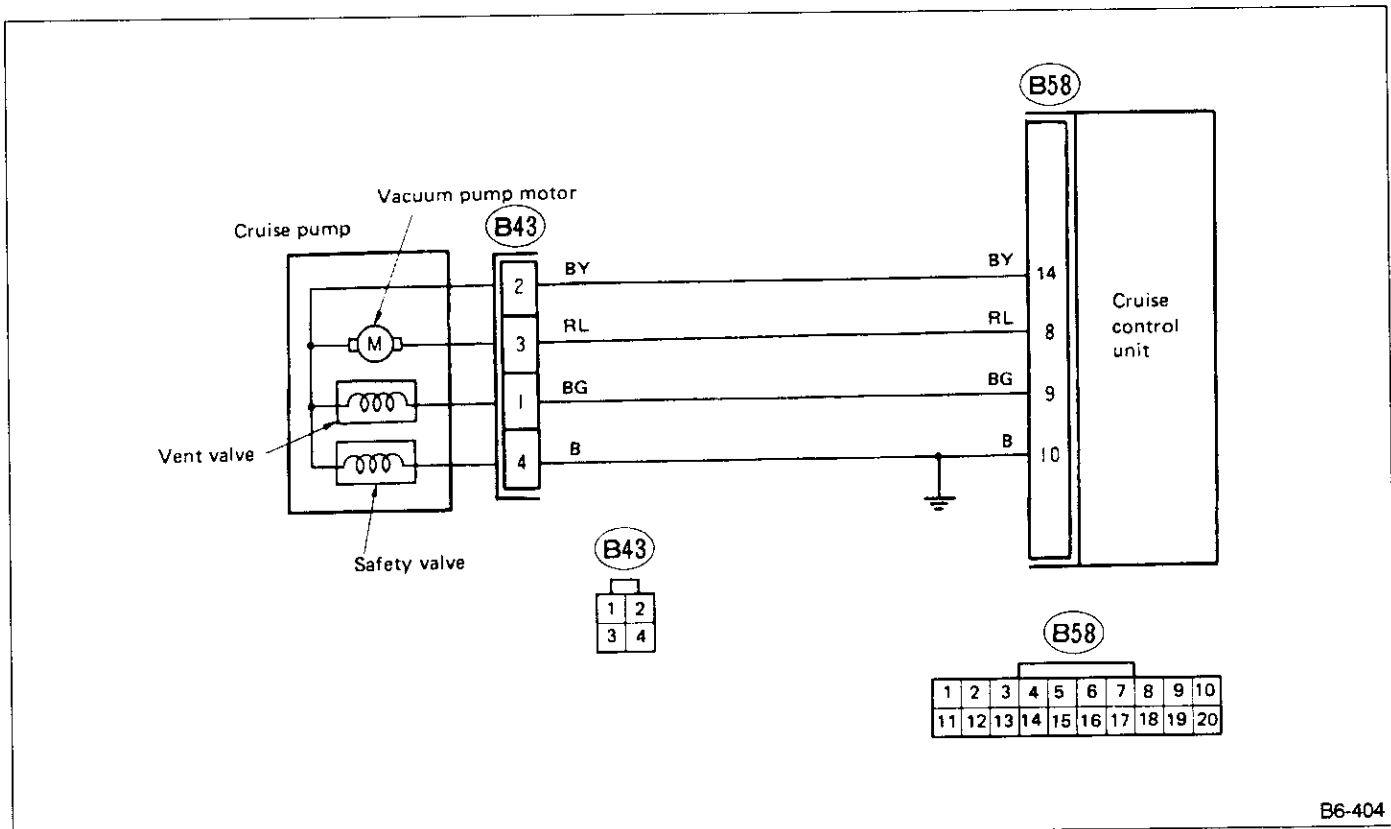
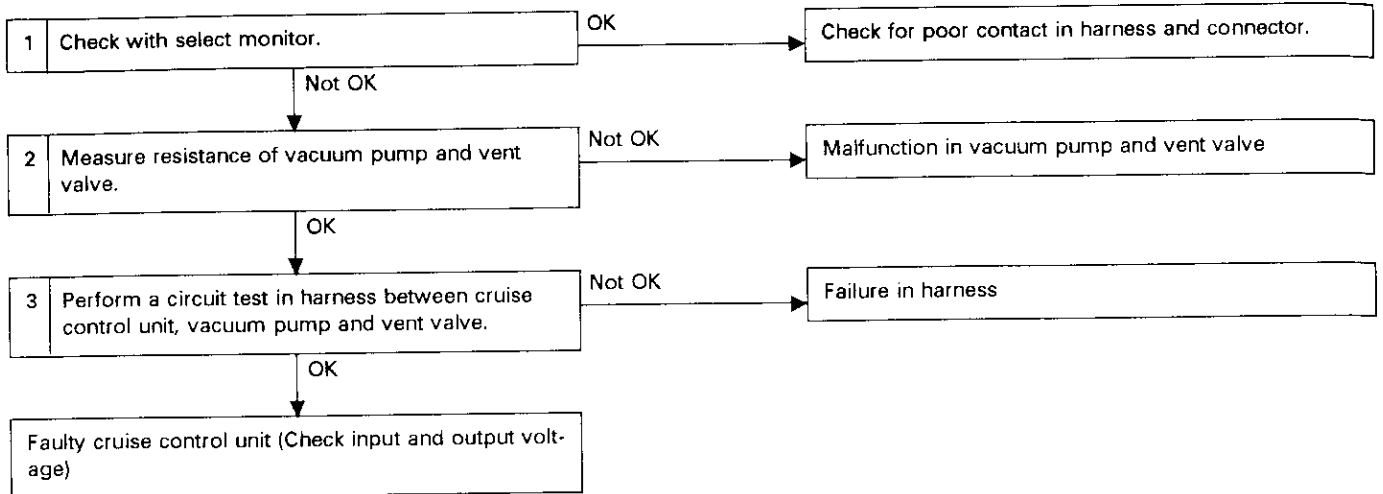


Fig. 167

1. CHECK WITH SELECT MONITOR.

- 1) Turn engine OFF.
- 2) Connect select monitor.
- 3) Turn ignition switch ON (the engine is OFF) and turn cruise control main switch ON.
- 4) Operation of function keys: **F B 1 ENT**
- 5) Confirm that the select lever is set in any other than the P, N range for the AT, and without depressing the clutch for the MT, then depress the 0 key.

The code number of the failuring parts will be indicated.

"Failure of the 31 MOTOR" will be indicated when setting in the P, N range (when depressing the clutch for MT). In this case, turn OFF the cruise main switch once, then turn it ON again and perform the same procedure.

F B 1 ENT



OUT PUT ready?	(FB1) Yes:0
----------------	----------------



0



OUT PUT 31 MOTOR	(FB1)
------------------	-------

Normal: Code (10)

Reference Code No. of malfunction

- Open or short circuit in vacuum motor and harness 31
- Open or short circuit in valve and harness 32
- Faulty valve drive circuit in cruise control unit . 34
- Faulty motor drive circuit in cruise control unit . 35
- Built-in relay of cruise control unit is stuck 33

2. MEASUREMENT OF COIL RESISTANCE IN VACUUM PUMP AND VENT VALVE

- 1) Separate the connector.
- 2) Measure the resistance value of the vacuum pump and vent valve. (Range $\Omega \times 1$)

Terminal/Specified resistance:

No. 2 — No. 3/100 — 110 Ω

No. 2 — No. 1/Approx. 53 Ω

No. 2 — No. 4/Approx. 53 Ω

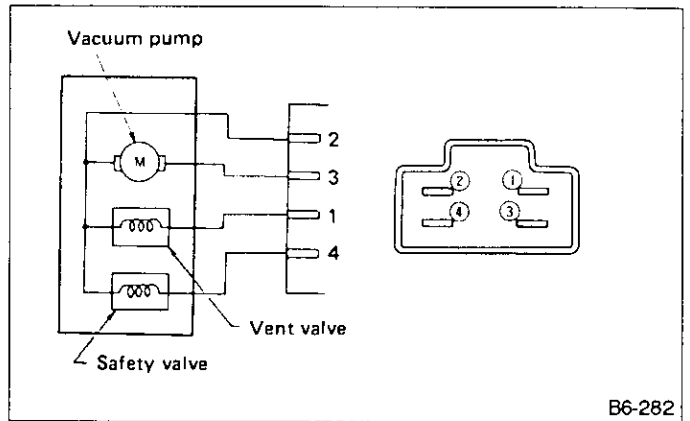


Fig. 168

3. CIRCUIT TEST IN HARNESS BETWEEN CRUISE CONTROL UNIT AND VACUUM MOTOR

- 1) Separate both sides of connectors.
- 2) Perform a circuit test between each of the harnesses.

Connector & Terminal/Specified resistance:

(B58) No. 14 — (B43) No. 2/1 Ω max.

(B58) No. 8 — (B43) No. 3/1 Ω max.

H: TROUBLE CODE 23 — MALFUNCTION IN BUILT-IN RELAY OF CRUISE CONTROL UNIT

CONTENT OF DIAGNOSIS:
Welding of built-in relay of cruise control unit

TROUBLE SYMPTOM:
Cruise canceling function does not operate, but fuel- safe function operates.

Perform real time diagnosis (FB1 mode) with select monitor, and replace cruise control unit when TROUBLE CODE 33 is indicated.

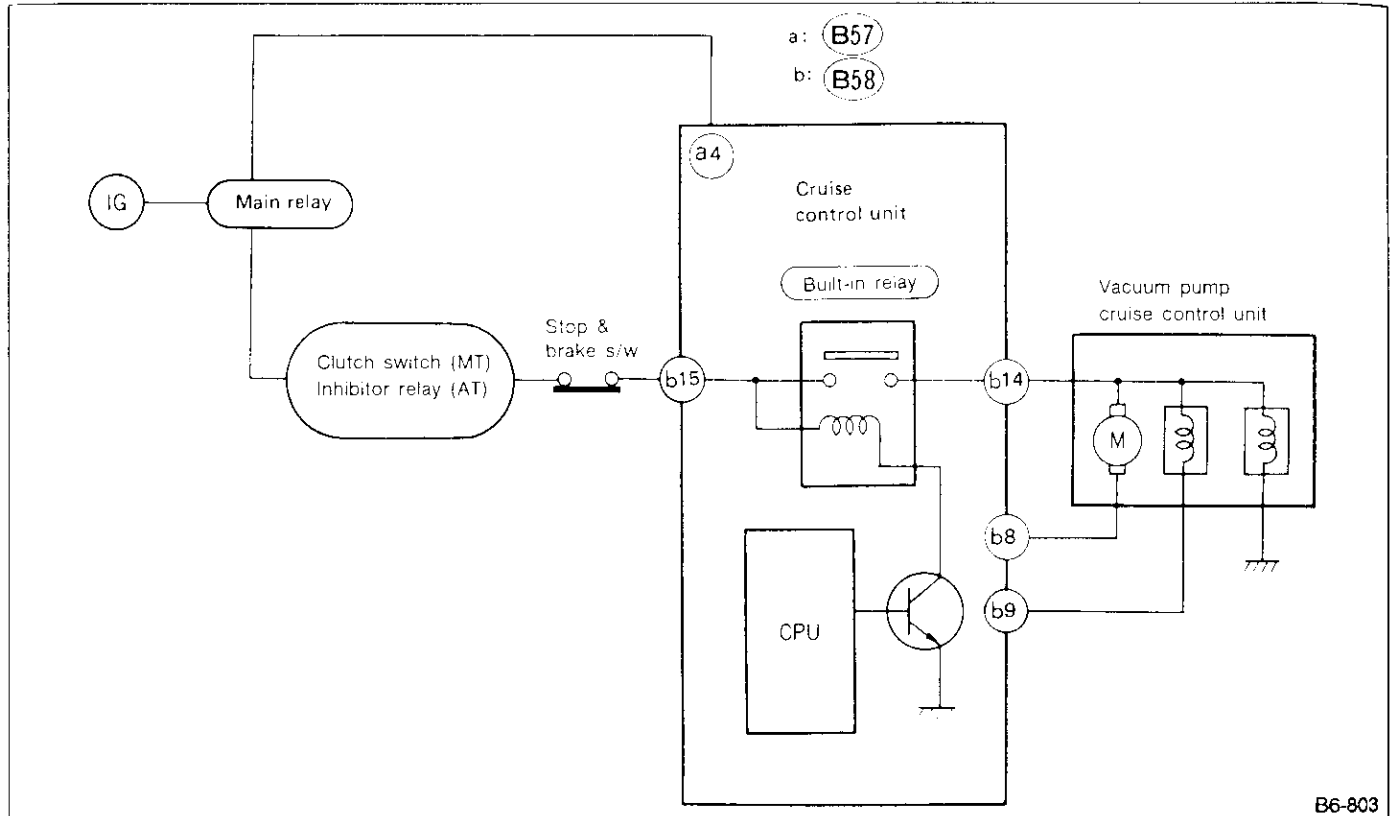
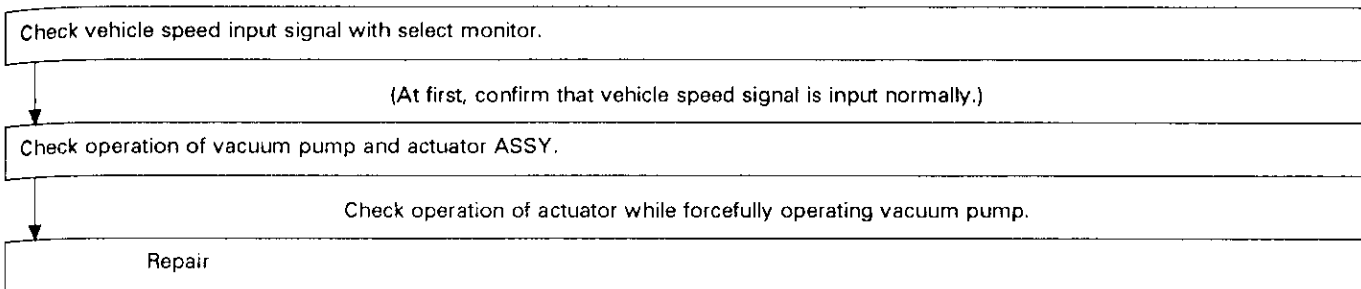


Fig. 169

B6-803

6. Trouble Chart C

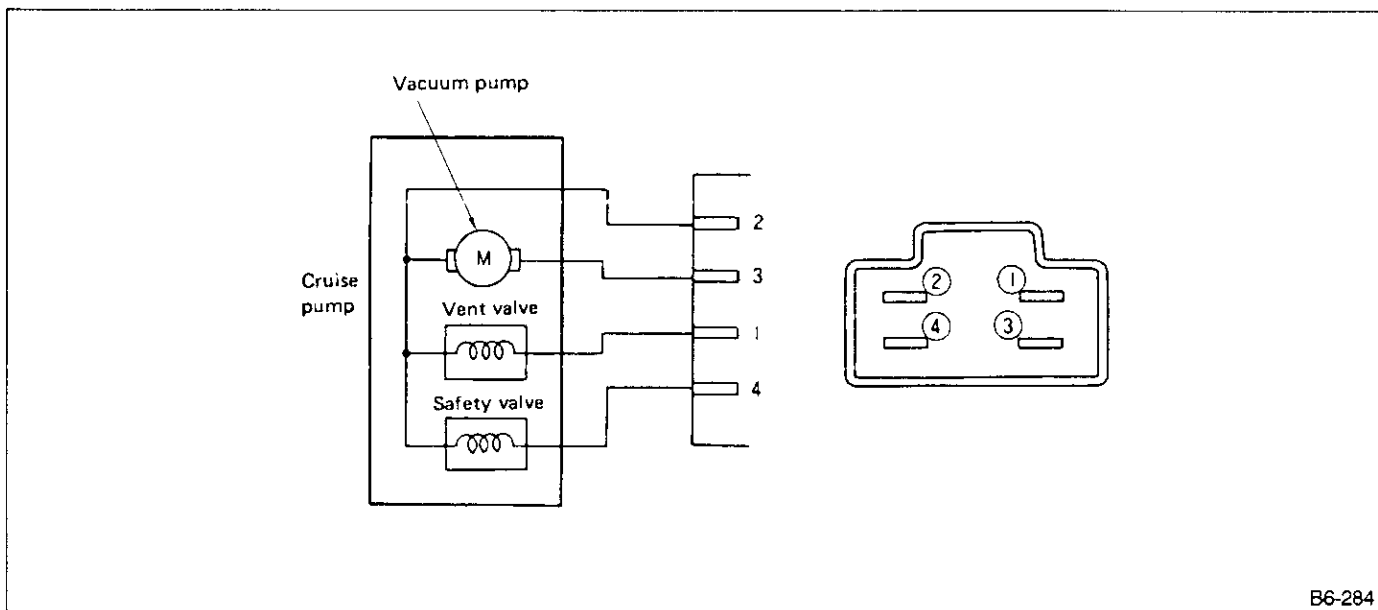
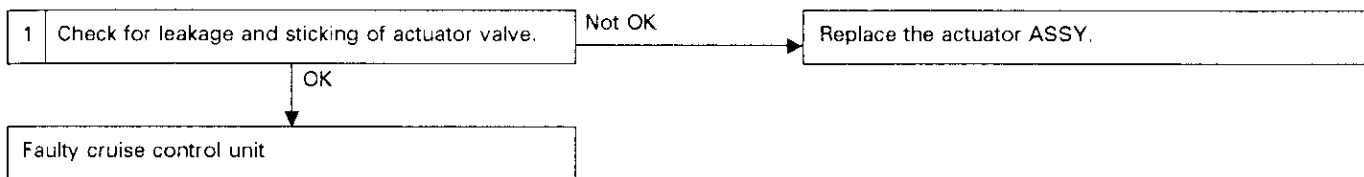
When not running at a fixed speed.



A: CHECK OPERATION OF VACUUM PUMP AND ACTUATOR ASSY

CONTENT OF DIAGNOSIS:
Sticking of air leaves of vacuum pump and actuator, or sticking of valve and actuator diaphragm

TROUBLE SYMPTOM:
Cannot run at set speed ± 3 km/h (± 2 MPH).



B6-284

Fig. 170

1. CHECK FOR LEAKAGE AND STICKING OF ACTUATOR VALVE.

- 1) Separate connector from vacuum pump.
- 2) Check for leakage of valve. (Perform this check when engine is OFF.)

Apply battery voltage (+) to cruise vacuum pump connector No. 2, and connect No. 1 and No. 4 to ground. After connecting No. 3 to ground, throttle vehicle should be fully opened within 3 seconds.

In case it closes too late: valve leakage

- 3) Check for sticking of valve.

Remove battery power source from No. 2.

After removing, throttle valve should be fully closed within 3 seconds.

In case it closes too late: valve sticking

: sticking of the actuator diaphragm

SUBARU®

1992

**SERVICE
MANUAL**



	Page
1. General Description	2
2. Working Precautions	9
3. How to Use Wiring Diagram	11
4. How to Use Super Multiple Junction (S.M.J.)	12
5. Wiring Diagram and Troubleshooting	14
1. POWER SUPPLY ROUTING	14
2. CHARGING	18
3. STARTING	19
4. ENGINE ELECTRICAL	22
5. COOLING FAN	36
6-1. LIGHTING (HEADLIGHTS)	37
6-2. LIGHTING (TAIL•ILLUMINATION•etc.)	40
7. ROOM LIGHT AND DOOR SWITCH	42
8. STOP LIGHT	46
9. TURN SIGNAL AND HAZARD	48
10. TRUNK ROOM LIGHT	49
11. BACK-UP LIGHT	50
12. REAR FOG LIGHT	51
13. AUTOMATIC TRANSMISSION CONTROL (4AT)	52
14. 4WD — MT	56
15. FRONT WIPER AND WASHER	58
16. REAR WIPER AND WASHER	59
17. HEADLIGHT WASHER	60
18. REAR WINDOW DEFOGGER	61
19. PARKING BRAKE AND BRAKE FLUID LEVEL WARNING	62
20. FUEL GAUGE	63
21. COMBINATION METER	64
22. OIL PRESSURE AND TEMPERATURE GAUGE	69
23. POWER WINDOW	70
24. DOOR LOCK	72
25. HORN AND CIGARETTE LIGHTER	73
26. SUNROOF•SPOT LIGHT AND VANITY MIRROR	74
27. RADIO AND POWER ANTENNA	77
28. MODE SELECTOR AND BLOWER MOTOR	78
29. REMOTE CONTROL REARVIEW MIRROR	79
30. PNEUMATIC (AIR) SUSPENSION	80
31. ANTILOCK BRAKE SYSTEM	82
32. CRUISE CONTROL	84
33. INTERCOOLER PUMP	86
34. FRONT FOG LIGHT	87
35. KEYLESS ENTRY	88
36. HEADLIGHT BEAM LEVELER	90
6. Electrical Unit Location	91
7. Electrical Wiring Harness and Ground Point	108

1. General Description

1. HOW TO USE THIS MANUAL

The description of the electrical system is divided into the charging system, starting system, etc.

1. First, open to the necessary electrical system section and wiring diagram.

2. Next, open the foldout page of the S.M.J. (super Multiple Junction) and that of the electrical wiring diagram. The S.M.J.'s terminal position is given, and by observing the electrical wiring harness' illustrations (front, instrument panel, etc.), the wiring diagram connector can be located.

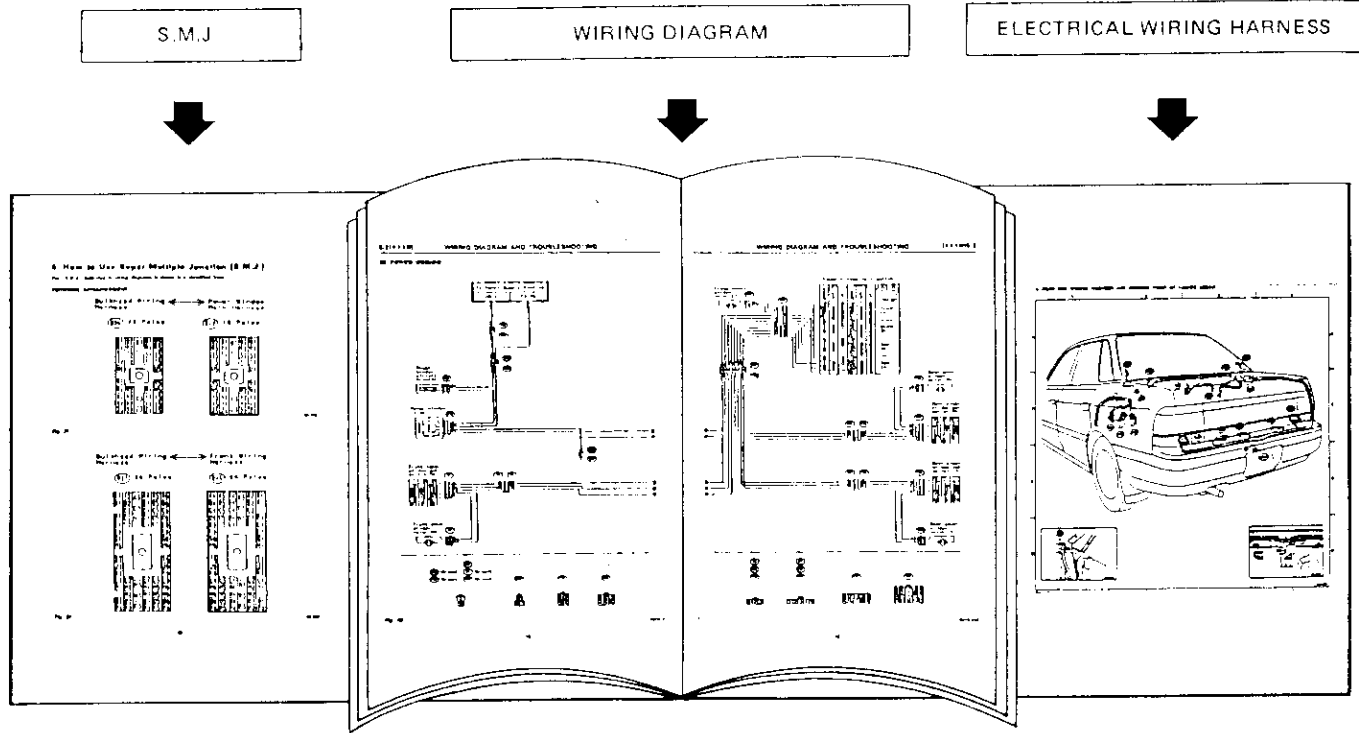


Fig. 1

B6-240

2. WIRING DIAGRAM

The wiring diagram of each system is illustrated so that you can understand the path through which the electric current flows from the battery.

Sketches and codes are used in the diagrams. They should read as follows:

1) Each connector and its terminal position are indicated by a sketch of the connector in a disconnected state which is viewed from the front, as shown in figure.

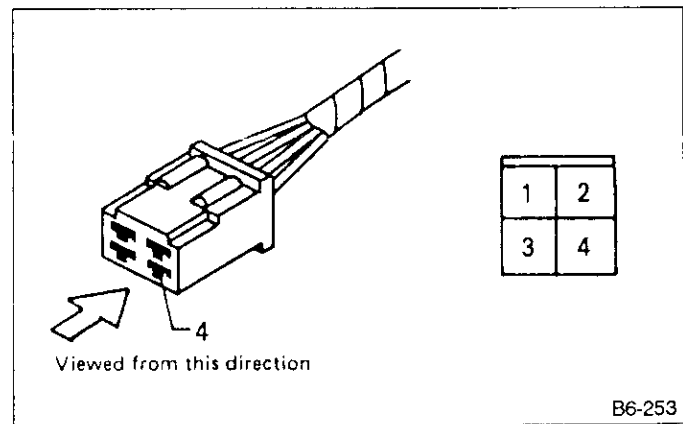


Fig. 2

B6-253

2) The number of poles or pins, presence of a lock, and pin number of each terminal are indicated in the sketch of each connector.

In the sketch, the highest pole number refers to the number of poles which the connector has. For example, the sketch of the connector shown in Figure 3 indicates the connector has 9 poles.

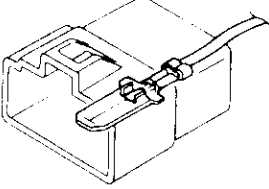
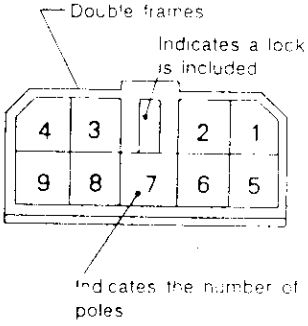
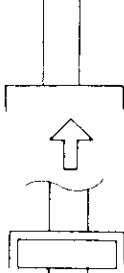
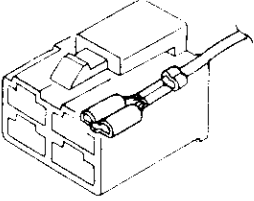
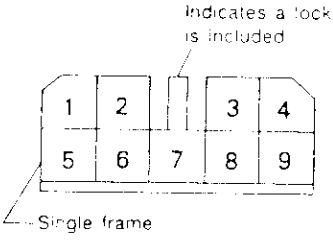
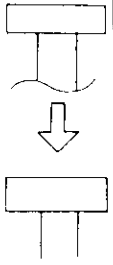
Connector used in vehicle	Connector shown in wiring diagram		
	Sketch	Symbol	Number of poles
			Numbered in order from upper right to lower left.
			Numbered in order from upper left to lower right.

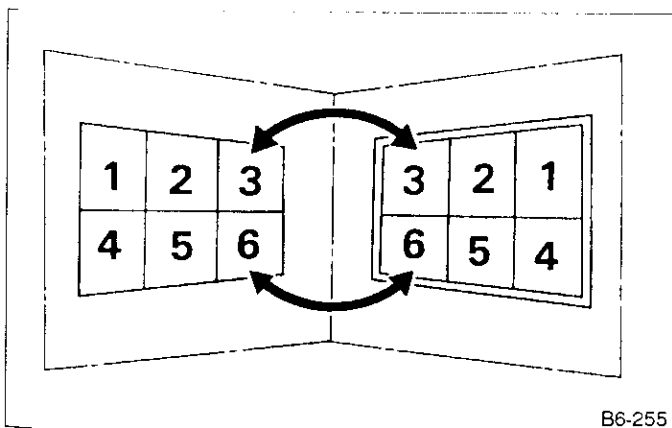
Fig. 3

B6-254

When one set of connectors is viewed from the front side, the pole numbers of one connector are symmetrical to those of the other. When these two connectors are connected as a unit, the poles which have the same number are joined.

3) Electrical wiring harness

The connectors are numbered along with the number of poles, external colors, and mating connections in the accompanying list.



B6-255

Fig. 4

4) The sketch of each connector in the wiring diagram usually shows the "A" side of the connector. The relationship between the wire color, terminal number and connector is described below.

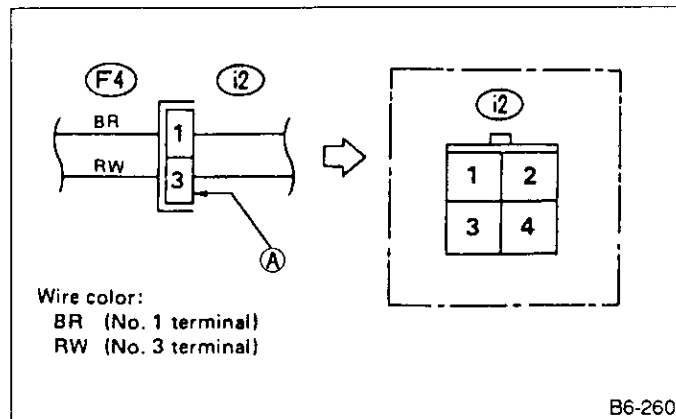


Fig. 5

A wire which runs in one direction from a connector terminal sometimes may have a different color from that which runs in the other direction from that terminal.

5) In wiring diagram, connectors which have no terminal number refer to one-pole types. Sketches of these connectors are omitted intentionally.

6) The following color codes are used to indicate the colors of the wires used.

Color code	Color
L	Blue
B	Black
Y	Yellow
G	Green
R	Red
W	White
Br	Brown
Lg	Light green
Gr	Gray
P	Pink
Or	Orange
Lb	Light Blue
SA	Sealed (Inner)
SB	Sealed (Outer)

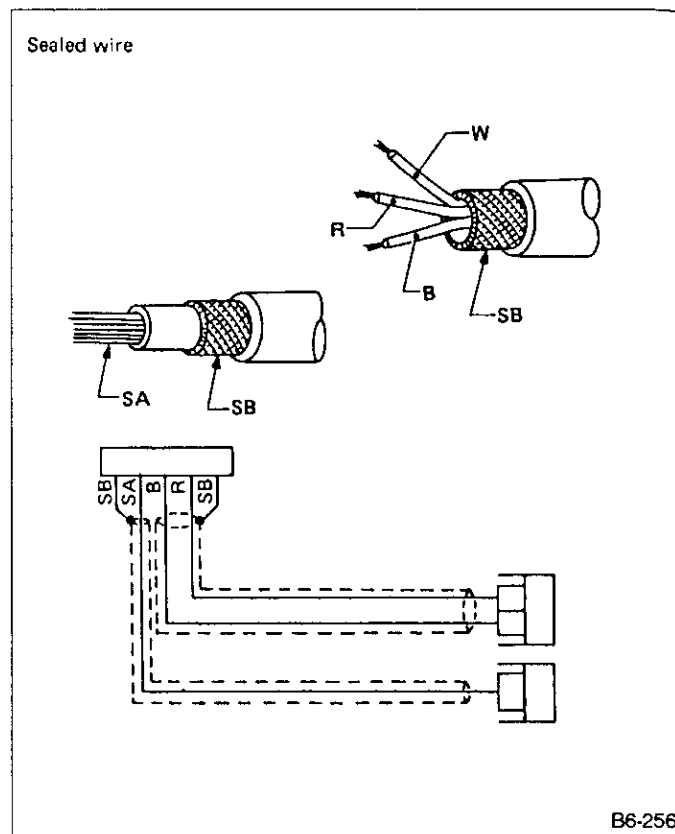


Fig. 6

7) The wire color code, which consists of two letters (or three letters including Br or Lg), indicates the standard color (base color of the wire covering) by its first letter and the stripe marking by its second letter.

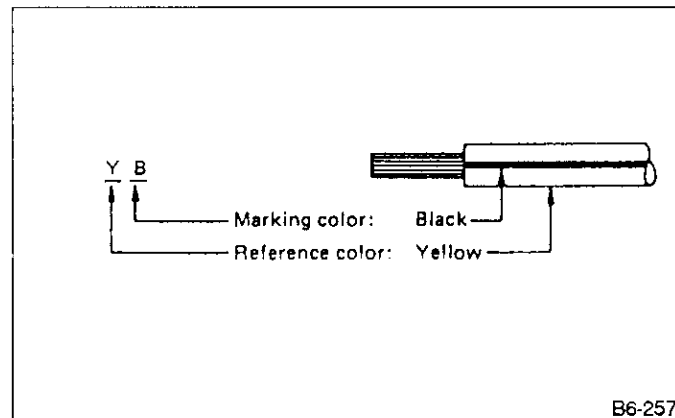


Fig. 7

8) The table below lists the nominal sectional areas and allowable currents of the wires.

Nominal sectional area mm ²	No. of strands/strand diameter	Outside diameter of finished wiring mm	Allowable current Amps/40°C
0.3	7/0.26	1.8	7
0.5	7/0.32	2.2 (or 2.0)	12
0.75	30/0.18	2.6 (or 2.4)	16
0.85	11/0.32	2.4 (or 2.2)	16
1.25	16/0.32	2.7 (or 2.5)	21
2	26/0.32	3.1 (or 2.9)	28
3	41/0.32	3.8 (or 3.6)	38
5	65/0.32	4.6 (or 4.4)	51
8	50/0.45	5.5	67

The ground points shown in the wiring diagram refer to the following:

- (GB) Body ground
- (GE) Engine ground
- (GR) Radio ground
- (GD) Rear defogger ground

All wiring harnesses are provided with a ground point which should be securely connected.

- a. The allowable current in the above table indicates the tolerable amperage of each wire at an ambient temperature of 40°C (104°F).
- b. The allowable current changes with ambient temperature. Also, it changes if a bundle of more than two wires is used.
- c. When replacing or repairing a wire, be sure to use the same size and type of the wire which was originally used.

9) Each unit is directly grounded to the body or indirectly grounds through a harness ground terminal. Different symbols are used in the wiring diagram to identify the two grounding systems.

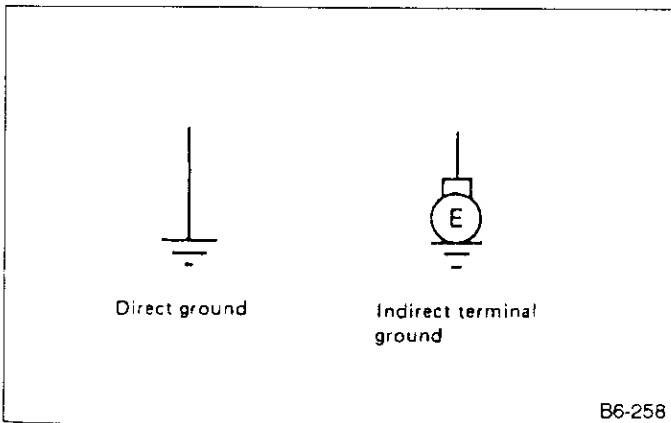


Fig. 8

10) Relays are classified as normally-open or normally-closed.
 The normally-closed relay has one or more contacts.
 The wiring diagram shows the relay mode when the energizing circuit is OFF.

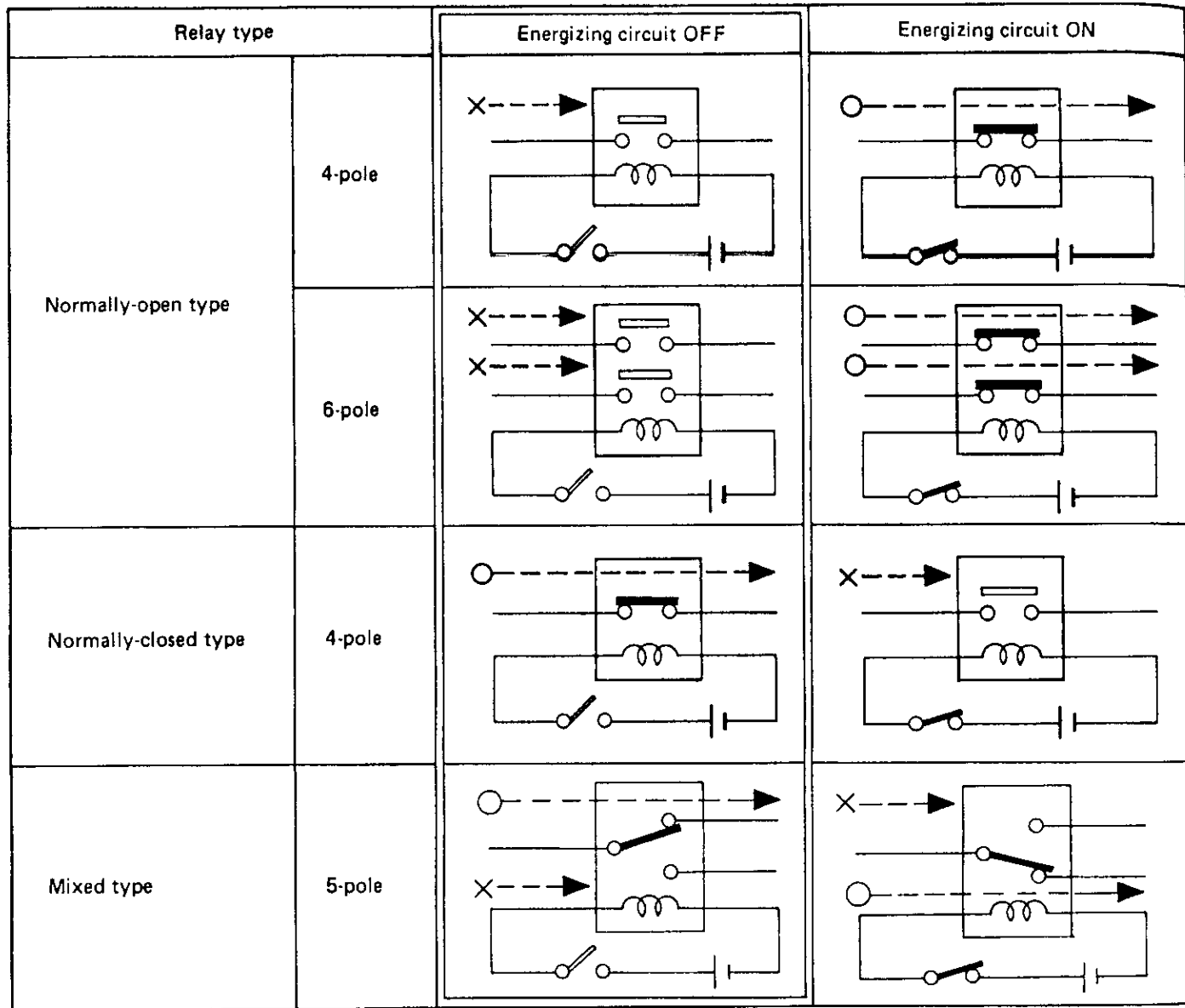


Fig. 9

B6-243

Key to symbols:

○ → : Current flows.

X → : Current does not flow.

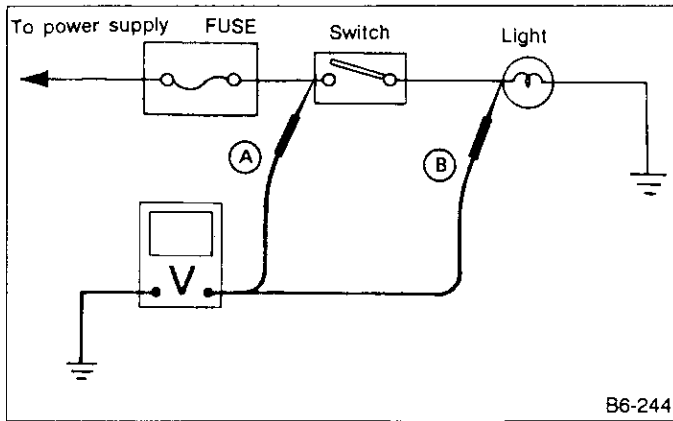


Fig. 11

5. CIRCUIT CONTINUITY CHECKS

- 1) Disconnect the battery terminal or connector so there is no voltage between the check points. Contact the two leads of an ohmmeter to each of the check points. If the circuit has diodes, reverse the two leads and check again.
- 2) Use an ohmmeter to check for diode continuity. When contacting the negative lead to the diode positive side and the positive lead to the negative side, there should be continuity. When contacting the two leads in reverse, there should be no continuity.

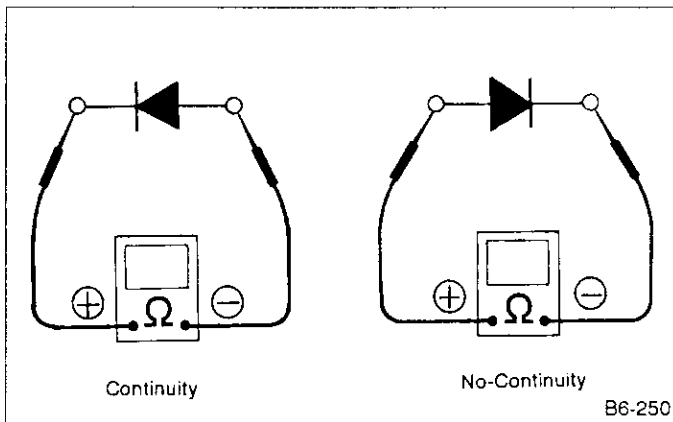


Fig. 12

3) Symbol "o—o" indicates that continuity exists between two points or terminals. For example, when a switch position is "3", continuity exists among terminals 1, 3 and 6, as shown in table below.

Terminal	1	2	3	4	5	6
Switch Position						
OFF						
1	o				o	o
2	o			o		o
3	o		o			o
4	o	o				o

6. HOW TO DETERMINE AN OPEN CIRCUIT

1) Voltmeter Method

An open circuit is determined by measuring the voltage between respective connectors and ground using a voltmeter, starting with the connector closest to the power supply. The power supply must be turned ON so that current flows in the circuit. If voltage is not present between a particular connector and ground, the circuit between that connector and the previous connector is open.

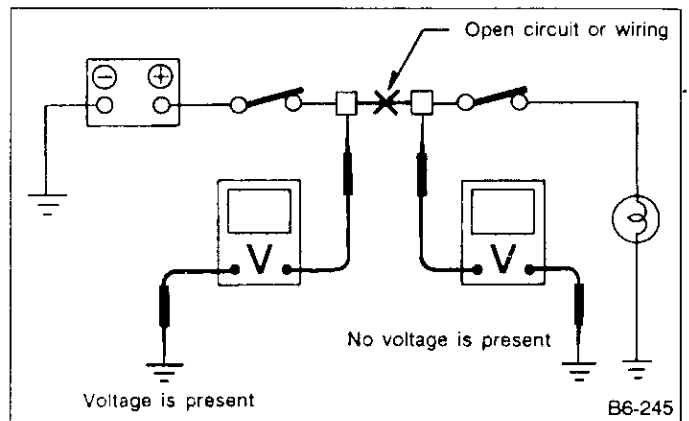
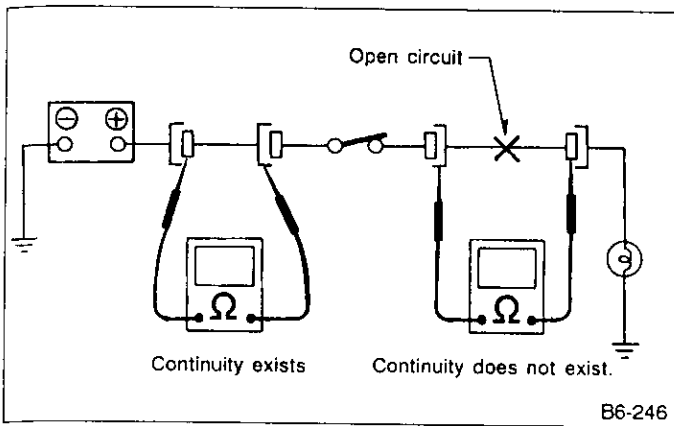


Fig. 13

2) Ohmmeter method

Disconnect all connectors affected, and check continuity in the wiring between adjacent connectors. When the ohmmeter indicates "infinite", the wiring is open.



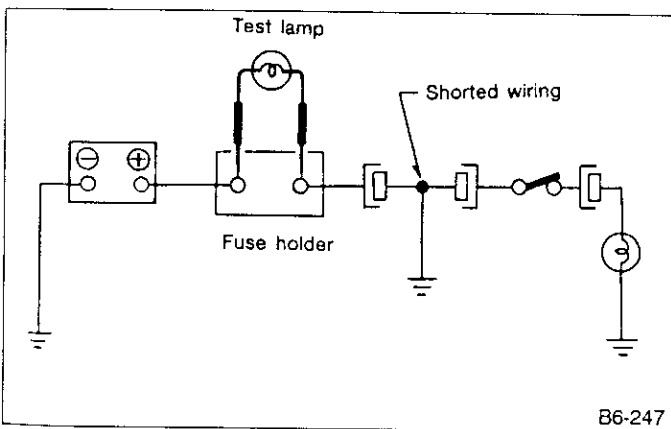
B6-246

Fig. 14

7. HOW TO DETERMINE A SHORT-CIRCUIT

1) Test lamp method

Connect a test lamp (rated at approximately 3 watts) in place of the blown fuse and allow current to flow through the circuit. Disconnect one connector at a time from the circuit, starting with the one located farthest from the power supply. If the test lamp goes out when a connector is disconnected, the wiring between that connection and the next connector (farther from the power supply) is shorted.

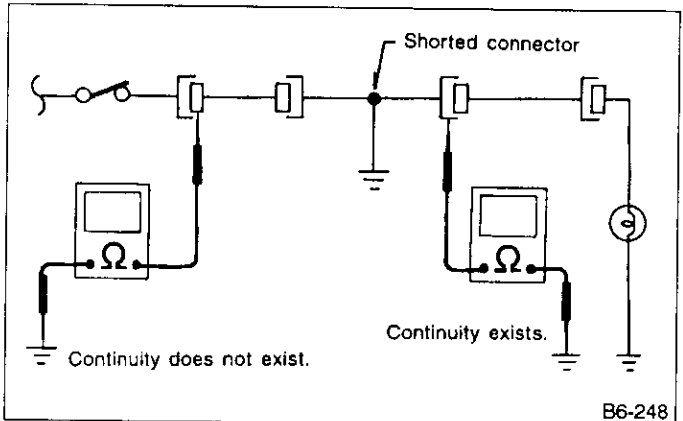


B6-247

Fig. 15

2) Ohmmeter method

Disconnect all affected connectors, and check continuity between each connector and ground. When ohmmeter indicates continuity between a particular connector and ground, that connector is shorted.



B6-248

Fig. 16

2. Working Precautions

1. PRECAUTIONS WHEN WORKING WITH THE PARTS MOUNTED ON THE VEHICLE

- 1) When working under a vehicle which is jacked up, always be sure to use safety stands.
- 2) The parking brake must always be applied during working. Also, in automatic transmission vehicles, keep the select lever set to the P (Parking) range.
- 3) Be sure the workshop is properly ventilated when running the engine. Further, be careful not to touch the belt or fan while the engine is operating.
- 4) Be careful not to touch hot metal parts, especially the radiator and exhaust system immediately after the engine has been shut off.

2. PRECAUTIONS IN TROUBLE DIAGNOSIS AND REPAIR OF ELECTRIC PARTS

- 1) The battery cable must be disconnected from the battery's (-) terminal, and the ignition switch must be set to the OFF position, unless otherwise required by the troubleshooting.
- 2) Securely fasten the wiring harness with clamps and slips so that the harness does not interfere with the body end parts or edges and bolts or screws.
- 3) When installing parts, be careful not to catch them on the wiring harness.

4) When disconnecting a connector, do not pull the wires, but pull while holding the connector body.

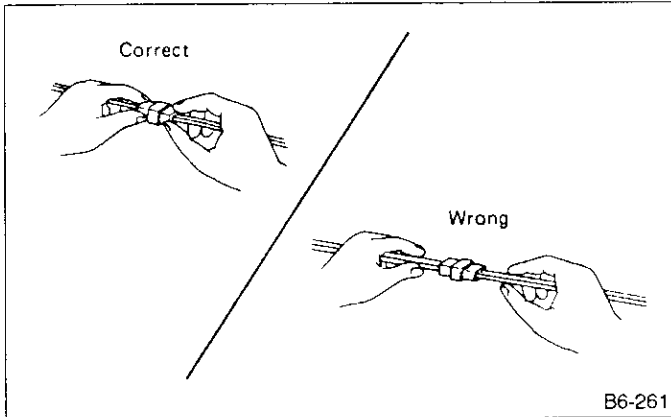


Fig. 17

5) Some connectors are provided with a lock. One type of such a connector is disconnected by pushing the lock, and the other, by moving the lock up. In either type the lock shape must be identified before attempting to disconnect the connector.

To connect, insert the connector until it snaps and confirm that it is tightly connected.

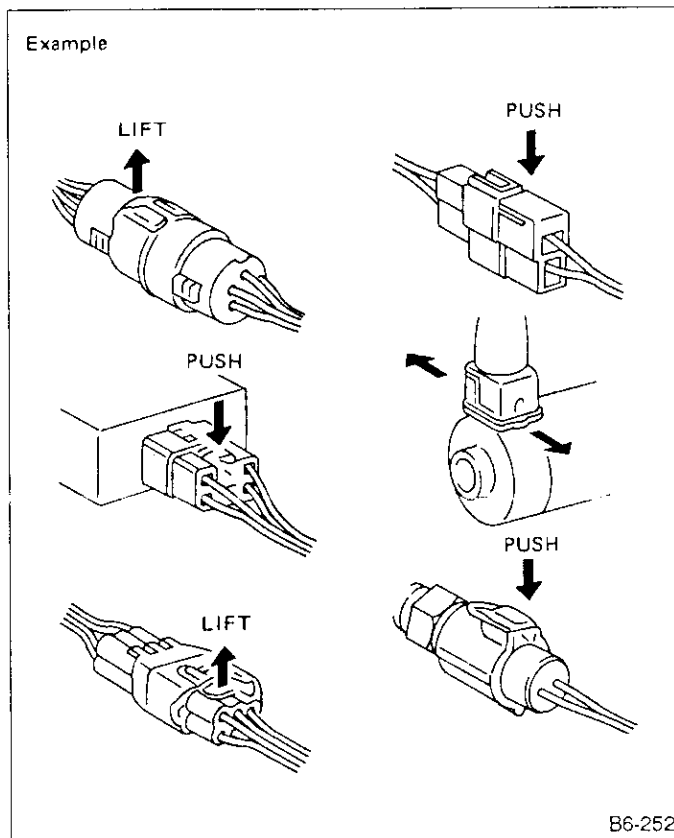


Fig. 18

6) When checking continuity between connector terminals, or measuring voltage across the terminal and ground, always contact tester probe(s) on terminals from the wiring connection side. If the probe is too thick to gain access to the terminal, use "mini" test leads. To check water-proof connectors (which are not accessible from the wiring side), contact test probes on the terminal side being careful not to bend or damage the terminals.

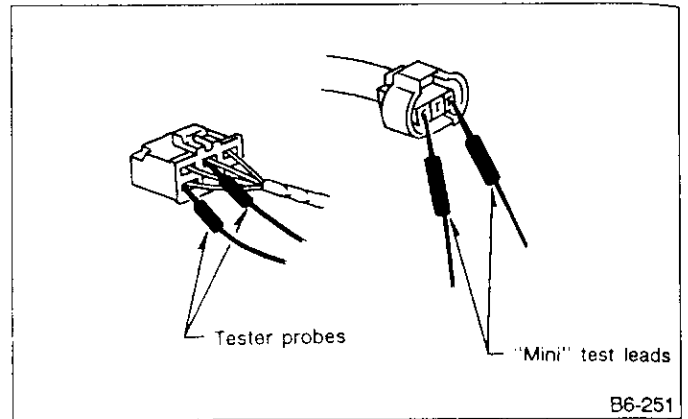


Fig. 19

7) Sensors, relays, electrical unit, etc., are sensitive to strong impacts. Handle them with care so that they are not dropped or mishandled.


3. How to Use Wiring Diagram


[0 3 0 0]

RELAY
A symbol used to indicate a relay.

POWER SUPPLY ROUTING
A symbol is used to indicate the power supply in each wiring diagram. "MB-5", "MB-6," etc., which are used as power-supply symbols throughout the text, correspond with those shown in the POWER SUPPLY ROUTING in the wiring diagram. Accordingly, using the POWER SUPPLY ROUTING and wiring diagrams permits service personnel to understand the entire electrical arrangement of a system.

SYMBOLS OF WIRE CONNECTION AND CROSSING

Symbol  Refers to wires which are connected and branched at the "dot" point.

Symbol  Refers to wires which are crossed but not connected.

SYMBOLS AND ABBREVIATIONS
A number of symbols and abbreviations are used in each wiring diagram to easily identify parts or circuits. < Refer to Abbreviation List >

S.M.J.
A symbol is used to indicate the terminal arrangement of the super multiple junction. The S.M.J. is not shown in respective wiring diagrams but is indicated on the next page.

DIODE
A symbol is used to indicate a diode.

WIRING CONNECTION
Some wiring diagrams are indicated in foldouts for convenience. Wiring destinations are indicated where necessary by corresponding symbols (as when two pages are needed for clear indication), as shown below.

FUSE NO. & RATING
The "FUSE NO. & RATING" corresponds with that used in the fuse box (main fuse box, fuse and joint box).

CONNECTOR

1. Each connector is indicated by a symbol.
2. Each terminal number is indicated in the corresponding wiring diagram in an abbreviated form.
3. For example, terminal number "C2" refers to No. 2 terminal of connector (C:F41) shown in the connector sketch.

CONNECTOR SKETCH

1. Each connector sketch clearly identifies the shape and color of a connector as well as terminal locations. Non-colored connectors are indicated in natural color.
2. When more than two types of connector number are indicated in a connector sketch, it means that the same type connectors are used.

GROUND
Each grounding point can be located easily by referring to the corresponding wiring harness.

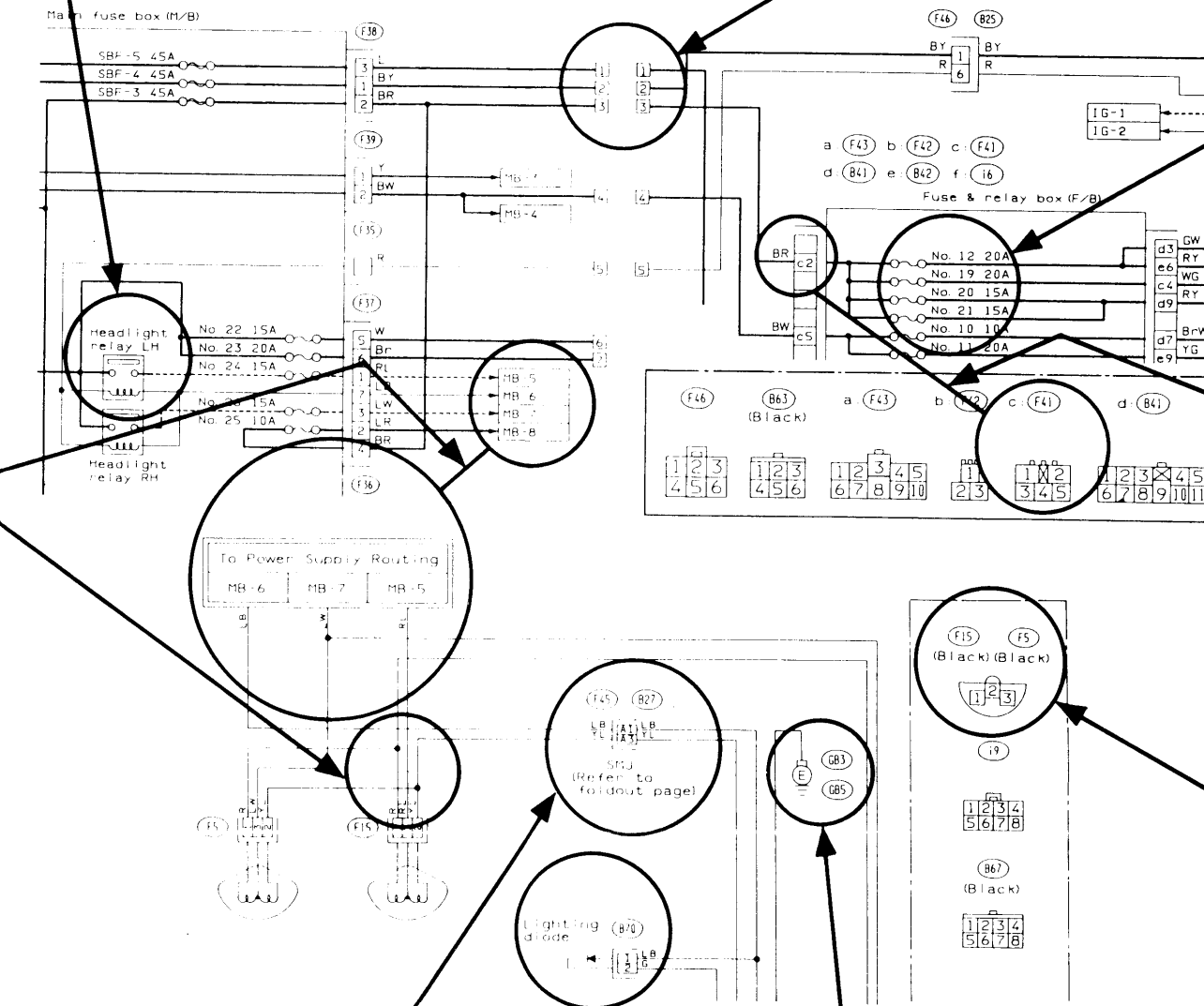


Fig. 20

B6-249

4. How to Use Super Multiple Junction (S.M.J.)

The "S.M.J." indicated in wiring diagrams is shown in a simplified form.

TERMINAL ARRANGEMENT

Bulkhead Wiring Harness ↔ Front Wiring Harness

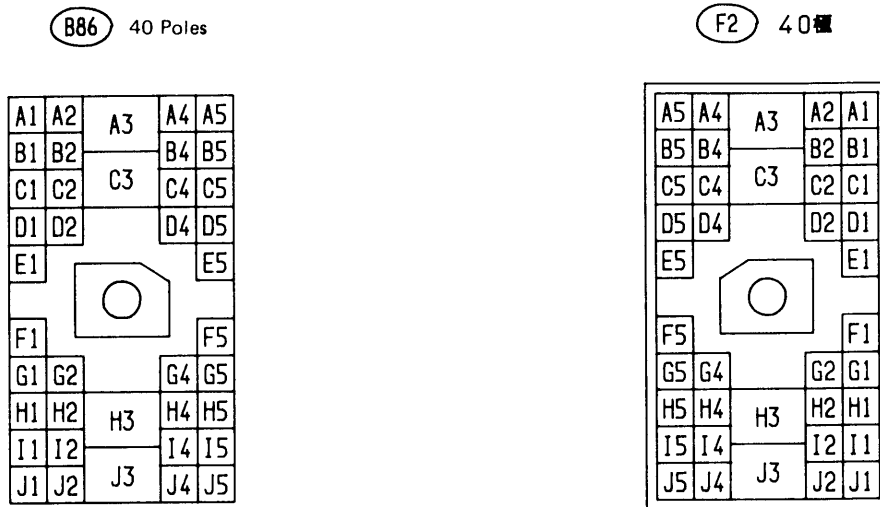


Fig. 21

Bulkhead Wiring Harness ↔ Rear Wiring Harness

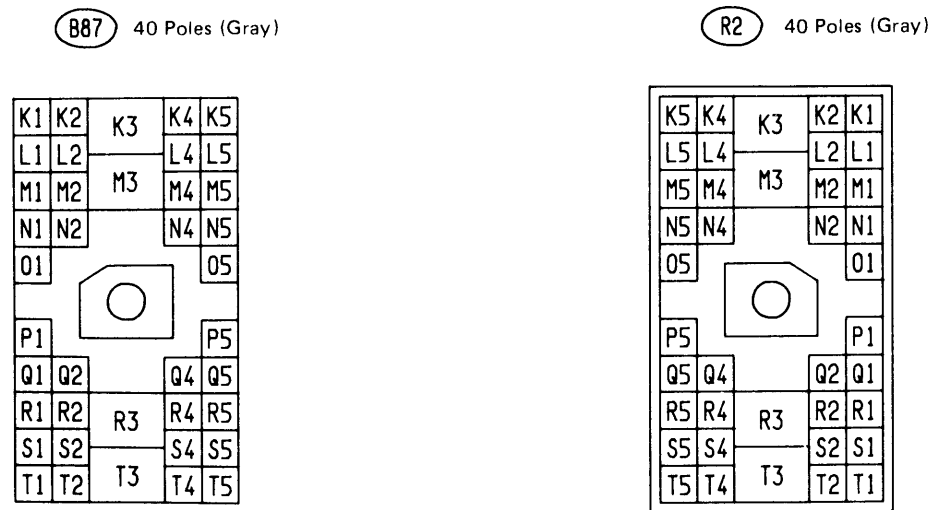


Fig. 22

INSTALLATION

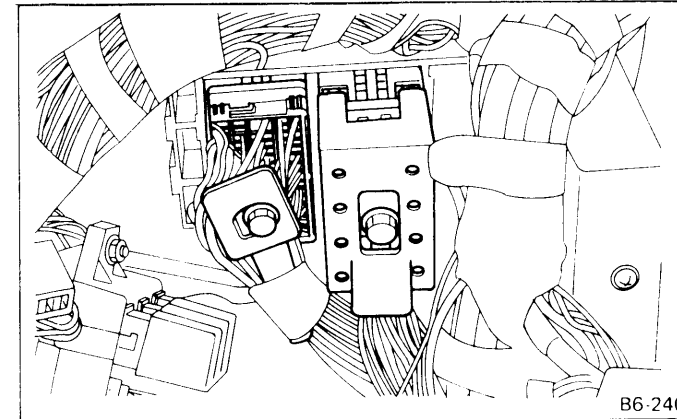


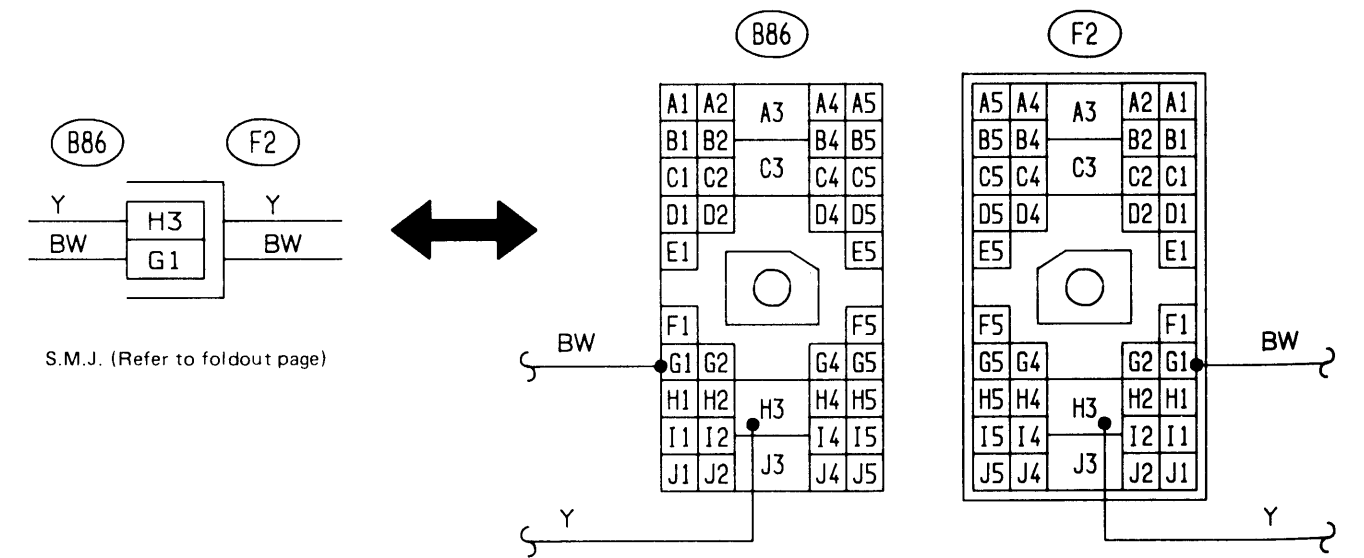
Fig. 23

Tightening torque:
4.4 – 7.4 N·m (45 – 75 kg·cm, 39 – 65 in·lb)

- Align the cutout portion of one connector with that of other before tightening the connecting bolt.
- Do not tighten the bolt excessively since this may deform the connectors.

B6-578

EXPLANATION OF S.M.J. SHOWN IN THE WIRING DIAGRAM



S.M.J. (Refer to foldout page)

Fig. 24

B6-579

B6-580

ABBREVIATION LIST

Abbr.	Full name
ABS	Antilock Brake System
ACC	Accessory
A/C	Air Conditioner
AD	Auto Down
A/S	Air Suspension
AT	Automatic Transmission
AU	Auto Up
+ B	Battery
CARB.	Carburetor model
DN	Down
Dr	Dual Range
DRL	Daytime Running Light
E	Ground
F/B	Fuse & Joint Box
FL1.25	Fusible link 1.25 mm ²
F/REC	FRESH/RECIRC
F/T	Full Time
IG	Ignition
Illumi.	Illumination
INT	Intermittent

Abbr.	Full name
ISC	Idle Speed Control
LH	Left Hand
Lo	Low
M	Motor
M/B	Main Fuse Box
MG	Magnet
Mi	Middle
MPFI	Multi Point Fuel Injection Model
MT	Manual Transmission
OP	Optional Parts
PASS	Passing
P/T	Part Time
RH	Right Hand
SBF	Slow Blow Fuse
S.M.J.	Super Multiple Junction
Sr	Single Range
ST	Starter
SW	Switch
UP	Up
WASH	Washer

5. Wiring Diagram and Troubleshooting

1. POWER SUPPLY ROUTING

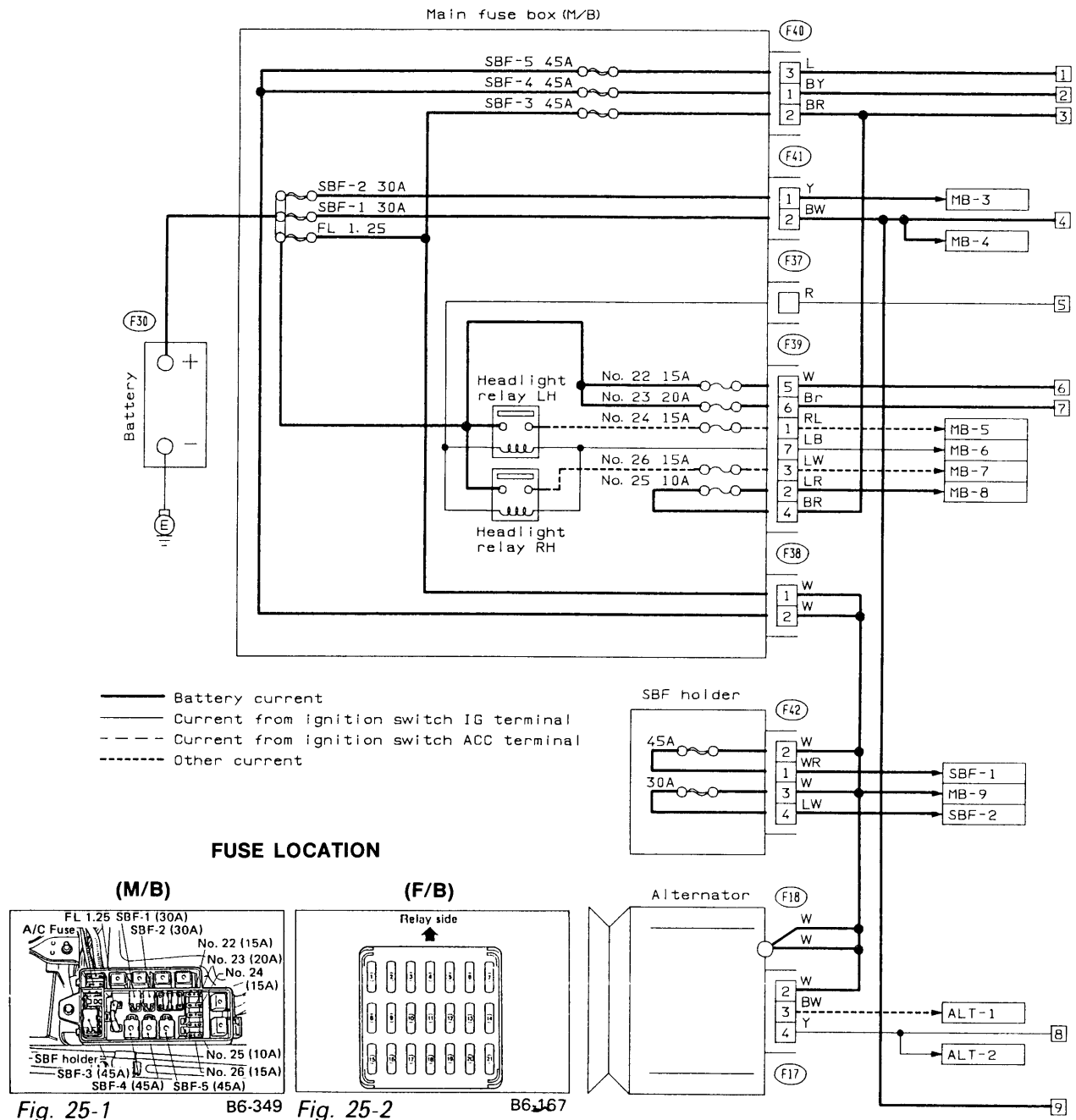


Fig. 25-1

B6-349

Fig. 25-2

B6-167

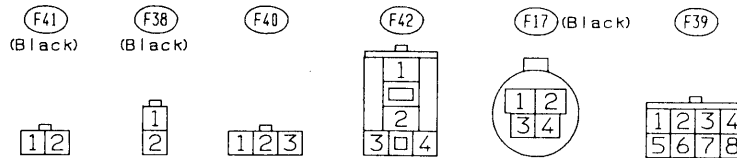
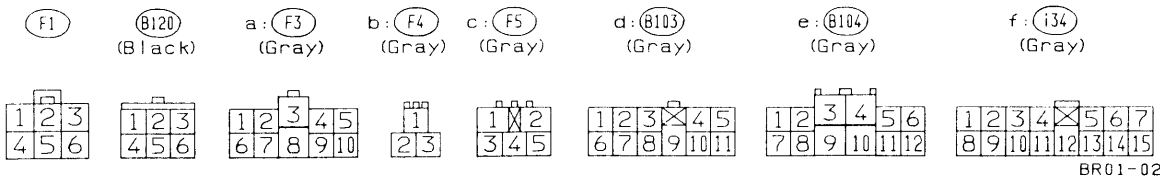
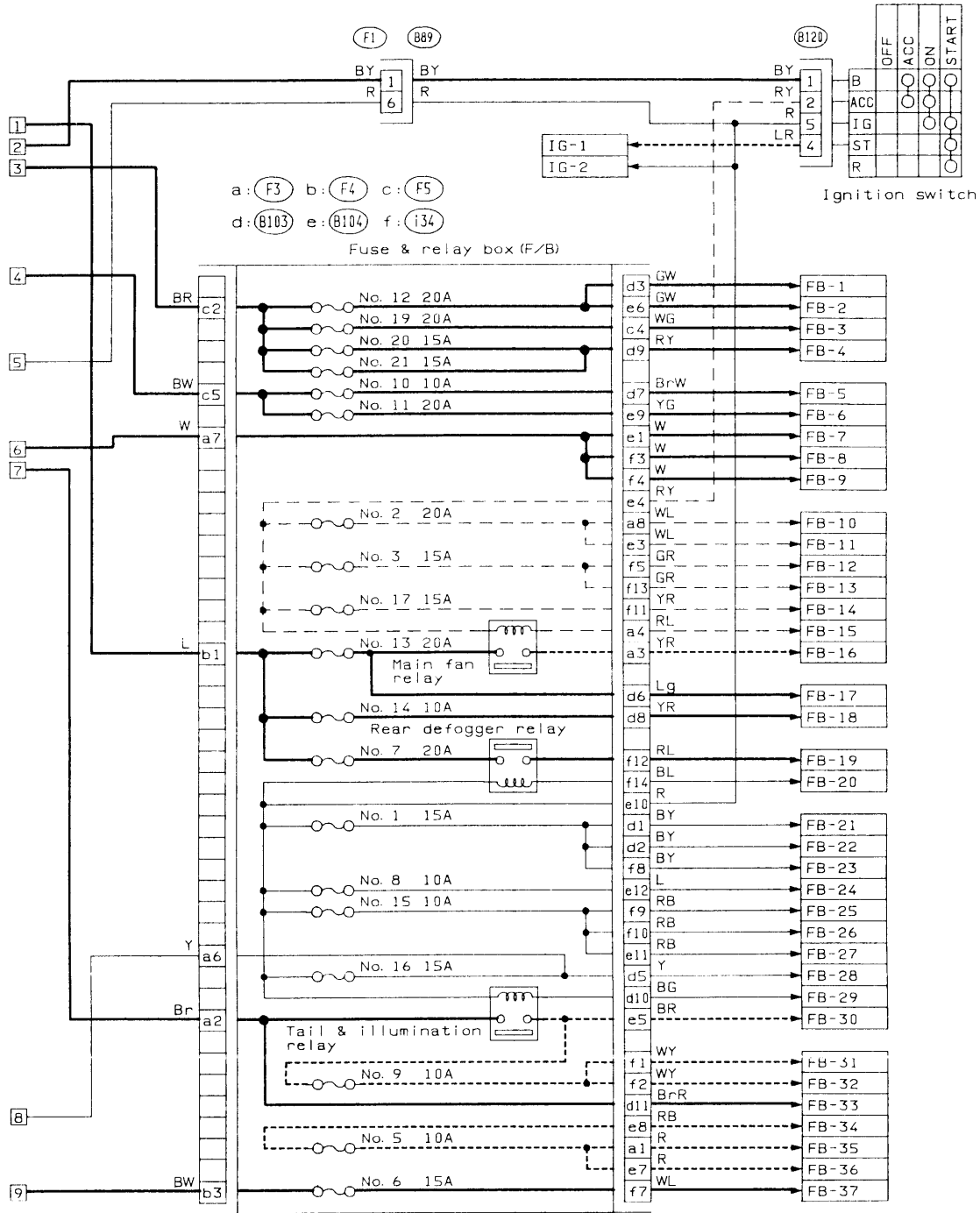


Fig. 25

BR01-02A



No.	Load
MB-3	Ignition relay: Fig. 29-1, 30-1 Fuel pump relay: Fig. 29-1, 30-1 Injector: Fig. 29-2, 30-2
MB-4	Headlight washer unit: Fig. 47 P/W circuit breaker: Fig. 58-1 Power window relay: Fig. 58-1, 55
MB-5	Headlight LH: Fig. 34, 35
MB-6	Lighting diode: Fig. 34, 35 Rear fog diode: Fig. 42 Diode (Lighting relay): Fig. 34, 35
MB-7	Headlight RH: Fig. 34, 35 Combination meter: Fig. 34, 35 Rear fog light relay: Fig. 42
MB-8	Room light: Fig. 37-1, 37-2 Step light: Fig. 37-1 Height control unit: Fig. 62 Luggage room light: Fig. 37-1, 37-2 Trailer connector: Fig. 37-1, 37-2, 40 Trunk room light: Fig. 40 Spot light: Fig. 58-1 Radio: Fig. 59 Clock: Fig. 59
MB-9	A/C (op)
SBF-1	Hydraulic unit: Fig. 63
SBF-2	A/S compressor: Fig. 62
ALT-1	Combination meter: Fig. 26, 38, 49
ALT-2	
IG-1	Inhibitor SW: Fig. 27, 28, 29-1 Starter motor: Fig. 2 MPFI unit: Fig. 29-1, 30-1
IG-2	A/C (OP)
FB-1	Stop light SW: Fig. 38, 43-1, 43-2, 63 Stop & Brake SW: Fig. 64
FB-2	Stop light SW: Fig. 38 Horn relay: Fig. 57 Horn condenser: Fig. 57
FB-3	Hydraulic unit: Fig. 63
FB-4	Blower motor relay: Fig. 60
FB-5	Charge solenoid: Fig. 62 A/S compressor relay: Fig. 62 Discharge solenoid: Fig. 62 A/S solenoid: Fig. 62
FB-6	Door lock SW: Fig. 56
FB-7	Power antenna: Fig. 59
FB-8	Hazard SW: Fig. 39
FB-9	Hazard SW: Fig. 39
FB-10	Front washer motor: Fig. 45
FB-11	Front wiper motor: Fig. 45 Front wiper SW: Fig. 45 Rear washer motor: Fig. 46 Rear wiper relay: Fig. 46 Rear wiper intermittent unit: Fig. 46 Rear wiper motor: Fig. 46
FB-12	Cigarette lighter: Fig. 57

No.	Load
FB-13	Remote control rearview mirror SW: Fig. 61
FB-14	Radio: Fig. 59 Power antenna SW: Fig. 59
FB-15	Radiator fan SW: Fig. 32 MPFI unit: Fig. 33
FB-16	Main fan motor: Fig. 32, 33
FB-17	A/C (OP)
FB-18	MPFI unit: Fig. 29-1, 30-1 AT unit: Fig. 43-1, 43-2
FB-19	Rear defogger SW: Fig. 48 Condenser: Fig. 48 Rear defogger (Heat wire): Fig. 48
FB-20	Rear defogger SW: Fig. 48
FB-21	Back-up light SW: Fig. 41 Inhibitor switch: Fig. 41 4WD selector SW: Fig. 44-2
FB-22	4WD selector SW: Fig. 44-2
FB-23	Hazard SW: Fig. 39
FB-24	ABS G sensor: Fig. 63 ABS control unit: Fig. 63 Cruise control main SW: Fig. 64 Main relay: Fig. 64
FB-25	Combination meter: Fig. 26, 29-1, 30-1, 31-1, 37-1, 37-2, 43-1, 43-2, 44-1, 44-2, 49, 50, 54, 62, 63 Rear fog light SW: Fig. 42 Rear fog light relay: Fig. 42 Headlight washer SW: Fig. 47 Mode control panel: Fig. 60 Height control SW: Fig. 62
FB-26	Combination meter: Fig. 26, 29-1, 30-1, 31-1, 37-1, 37-2, 43-1, 43-2, 44-1, 44-2, 49, 50, 54, 58-1, 62, 63 Rear fog light SW: Fig. 42 Rear fog light relay: Fig. 42 Headlight washer SW: Fig. 47 Mode control panel: Fig. 60 Height control SW: Fig. 62
FB-27	Dim-dip cancel relay: Fig. 35 Main beam cancel relay: Fig. 35 Dim-dip relay: Fig. 35 Check connector: Fig. 43-1, 43-2, 62 P/W relay: Fig. 55, 58-1 Vanity mirror illumi.: Fig. 58-1 Blower motor relay: Fig. 60 F/C actuator: Fig. 60 Mode actuator: Fig. 60
FB-28	Igniter: Fig. 27, 29-2, 30-2 Ignition coil: Fig. 27, 28, 29-2, 30-2, 31-2, 32 Distributor: Fig. 28, 32 Fuel pump relay: Fig. 29-1, 30-1 Diode (MPFI): Fig. 29-1, 30-1 MPFI unit: Fig. 29-1, 30-1 Noise condenser: Fig. 32 Revolution sensor: Fig. 32 Carburetor solenoid: Fig. 32 AT unit: Fig. 43-1, 43-2 AT economy SW: Fig. 43-1, 43-2

No.	Load
FB-29	Lighting SW: Fig. 35
FB-30	Dim-dip control relay: Fig. 35 Parking light SW: Fig. 36
FB-31	Illumination cancel SW: Fig. 36 Illumination light: Fig. 36
FB-32	Illumination control unit: Fig. 36 Illumination light: Fig. 36
FB-33	Parking light SW: Fig. 36

No.	Load
FB-34	Parking light SW: Fig. 36
FB-35	Front clearance light: Fig. 36
FB-36	Trailer connector: Fig. 36 Rear combination light: Fig. 36 Licence plate light: Fig. 36

2. CHARGING

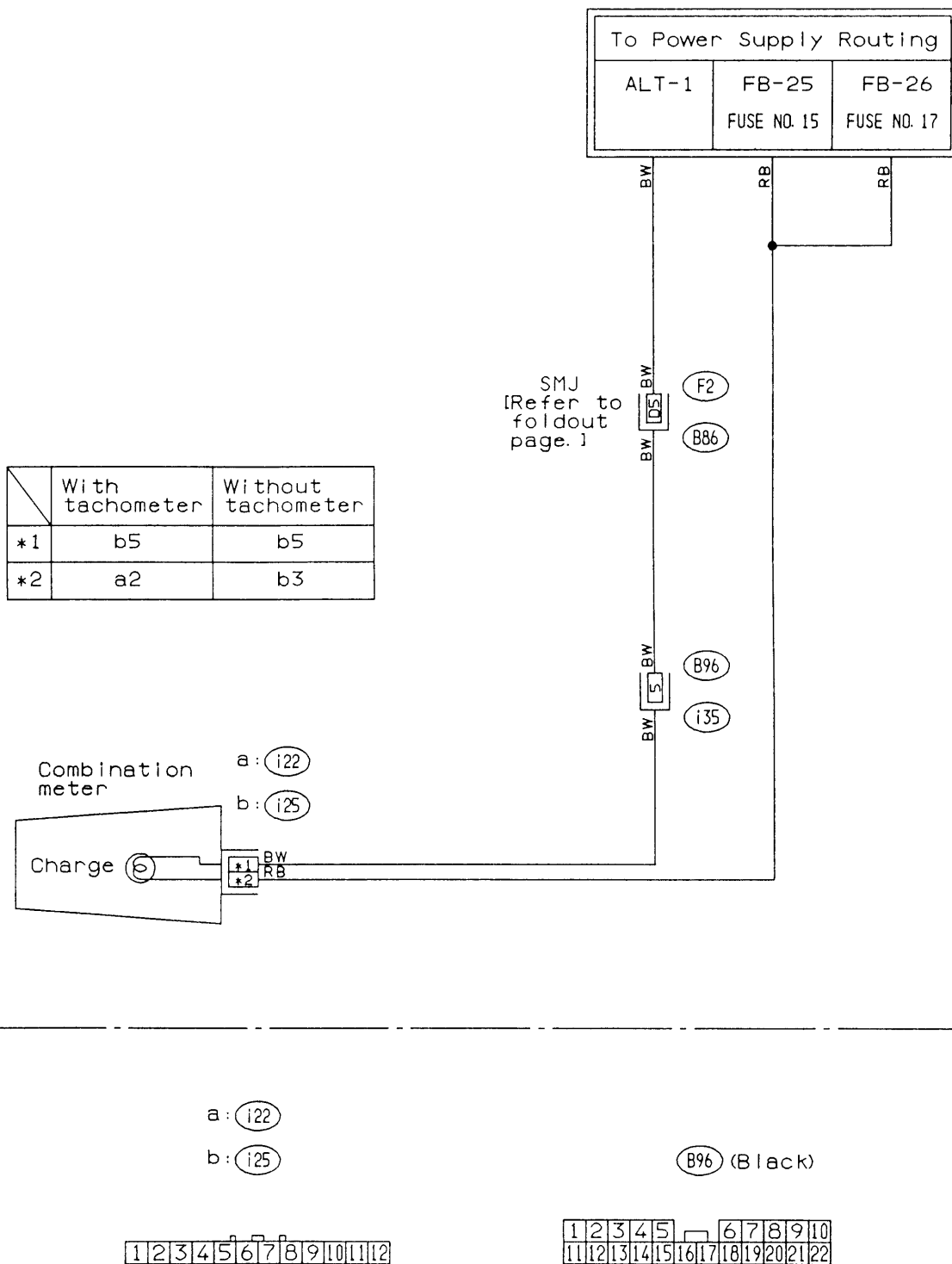
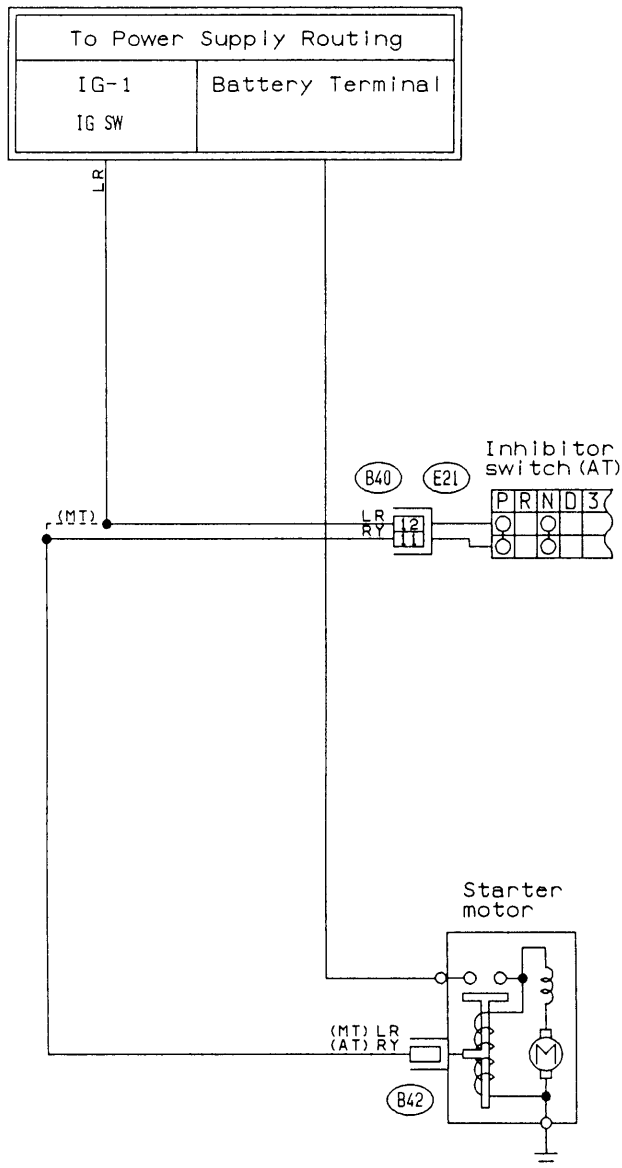


Fig. 26

BR02-02

3. STARTING
MPFI MODEL



B40 (Gray)

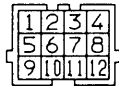
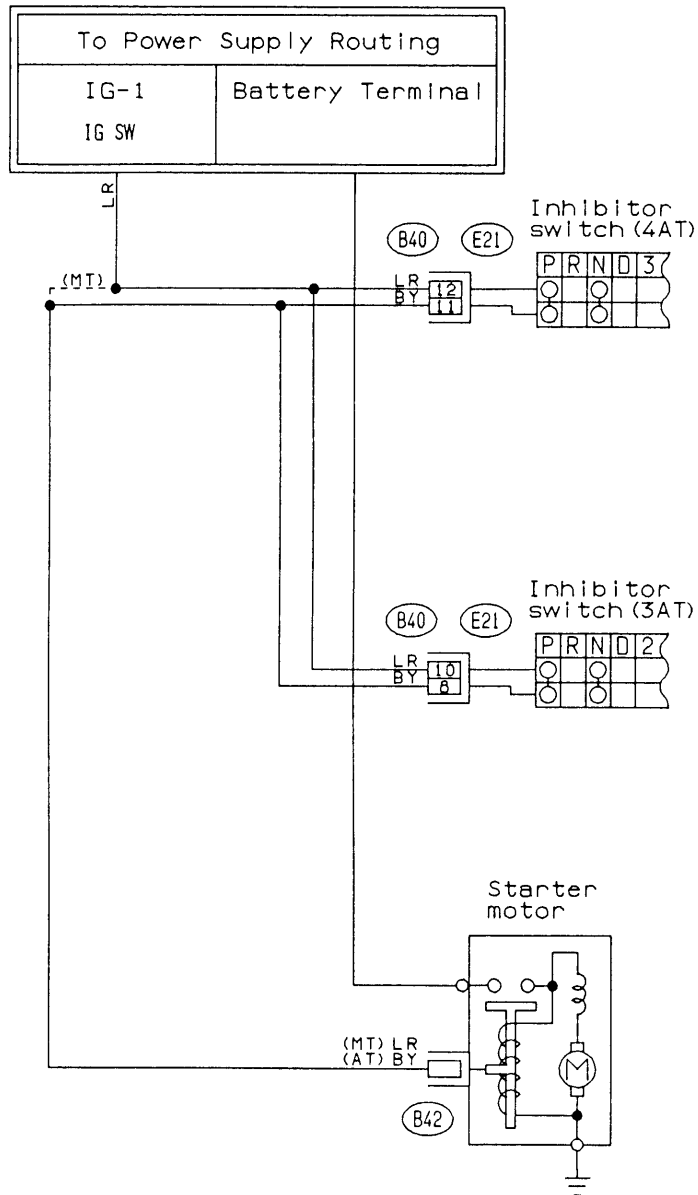
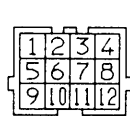


Fig. 27

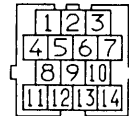
SPFI/CARBURETOR MODEL



(B40) (Gray)



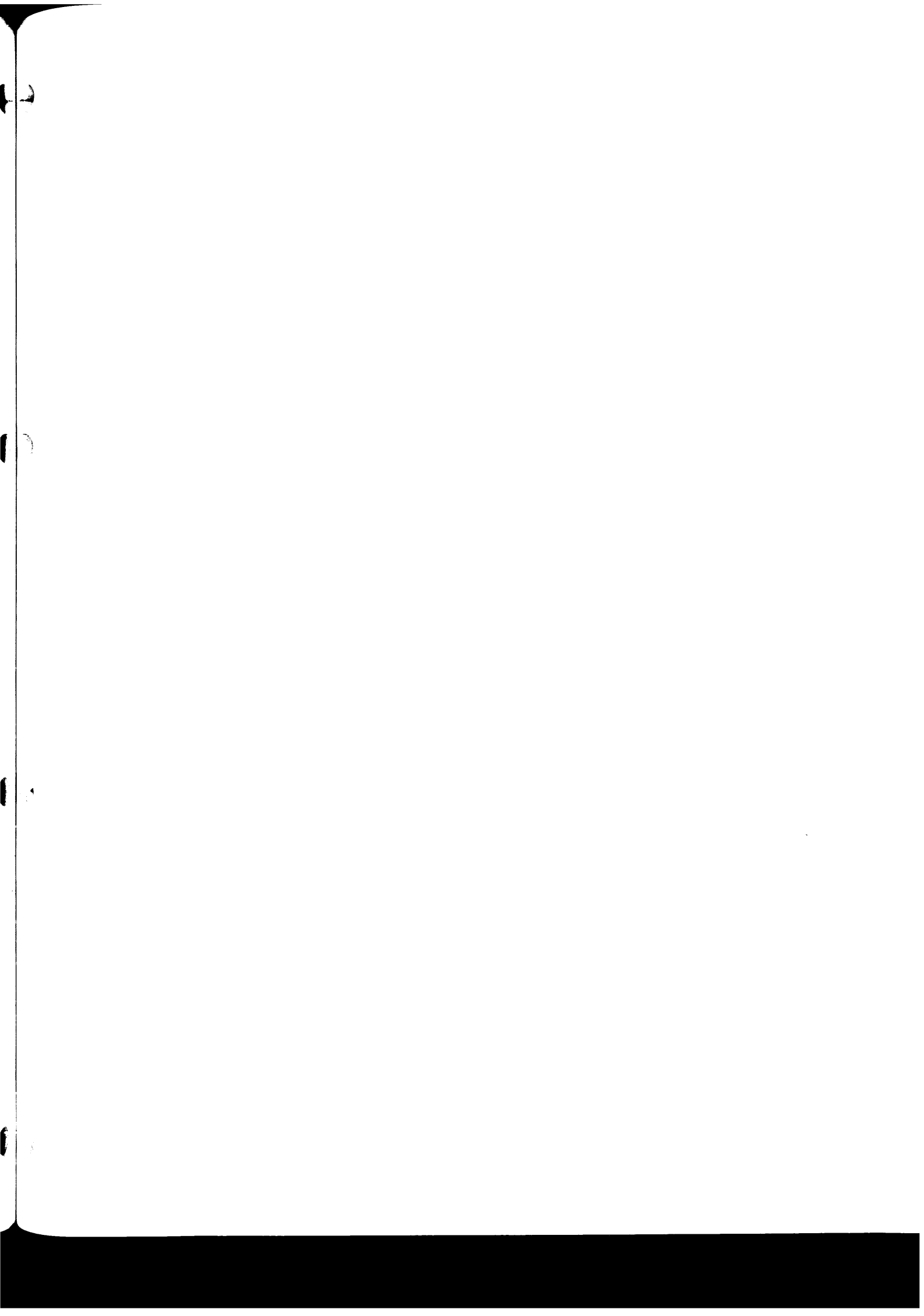
(4AT)



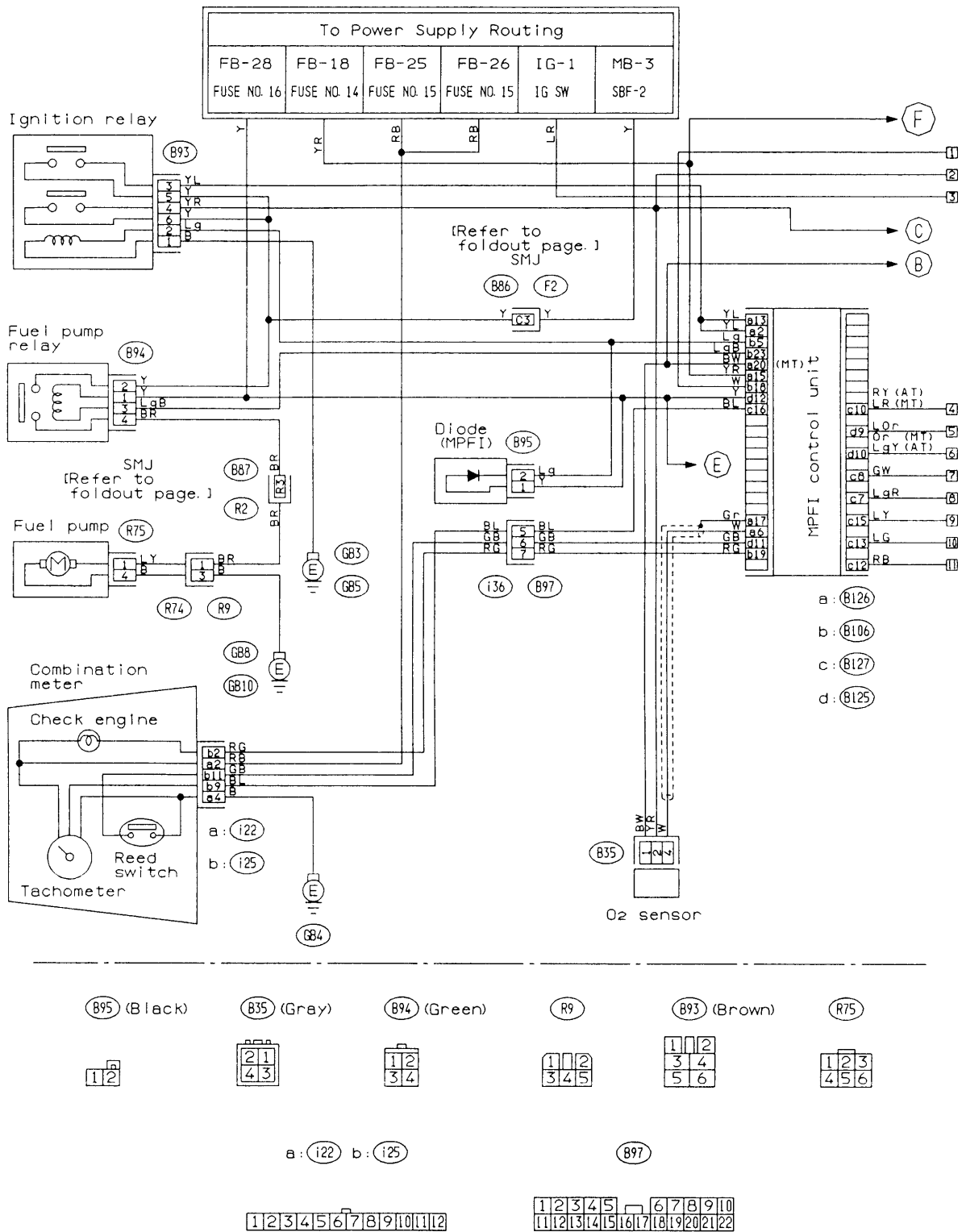
(3AT)

BR03-05

Fig. 28

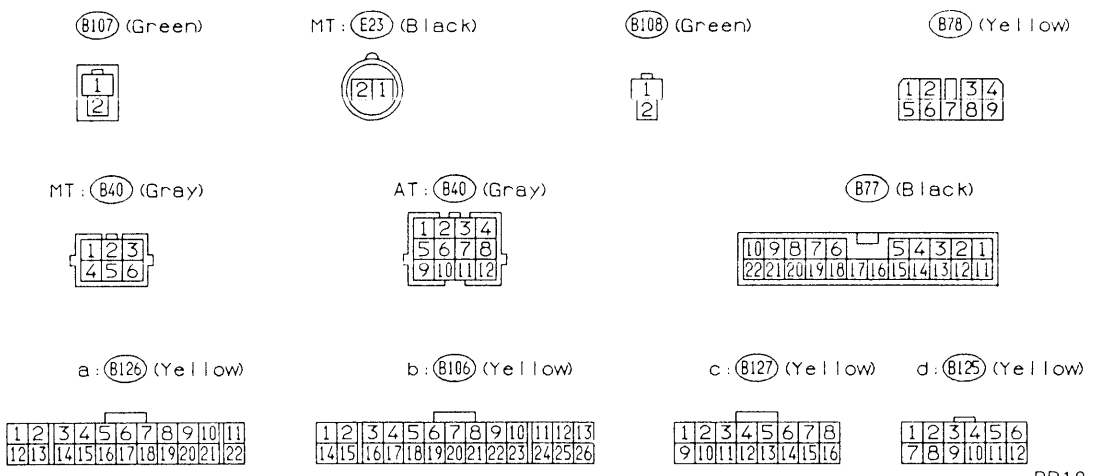
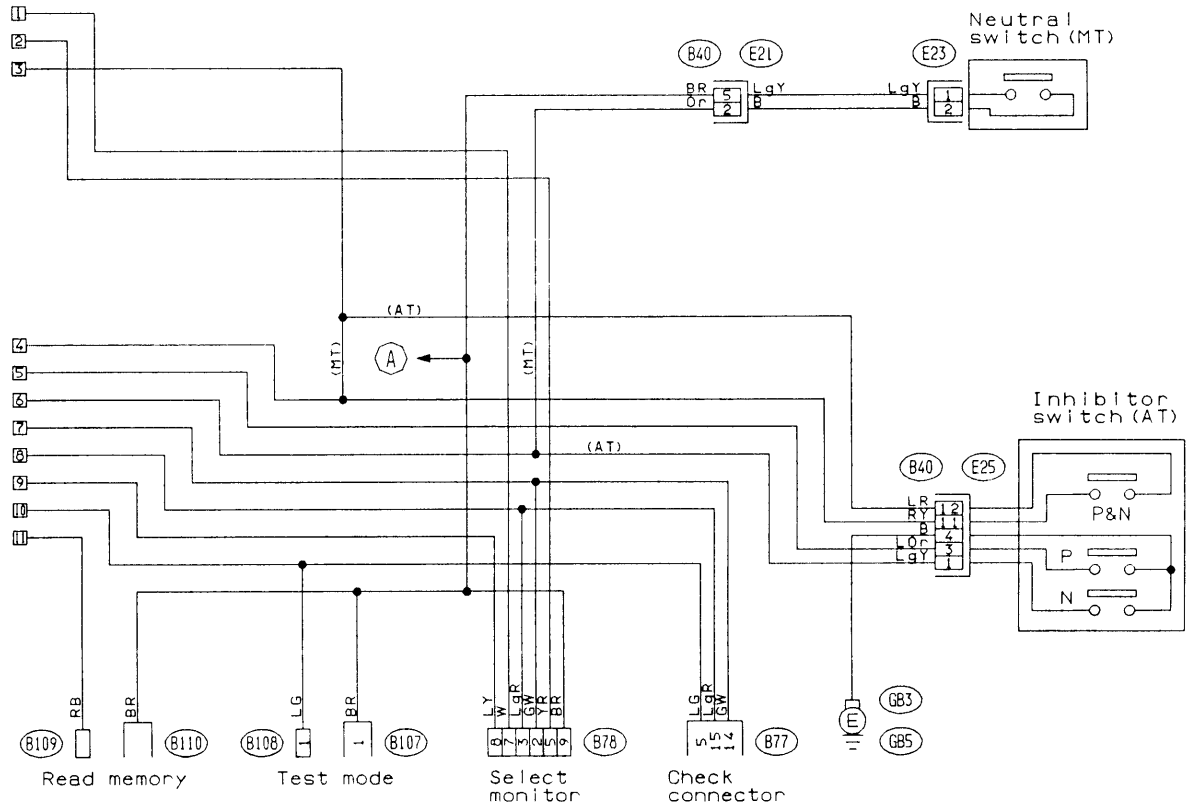


**4. ENGINE ELECTRICAL
MPFI MODEL (NA)**

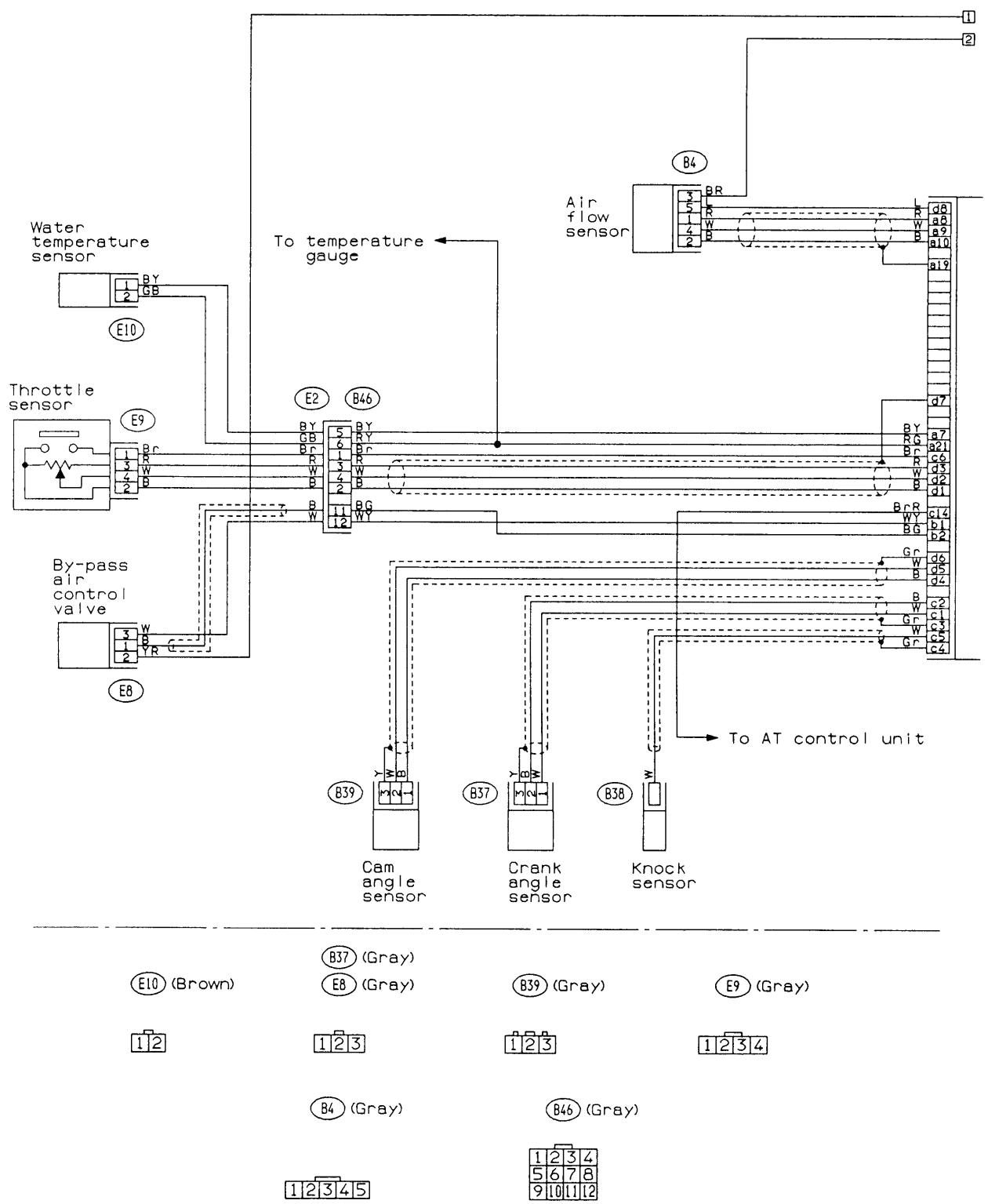


BR10-03A

Fig. 29-1

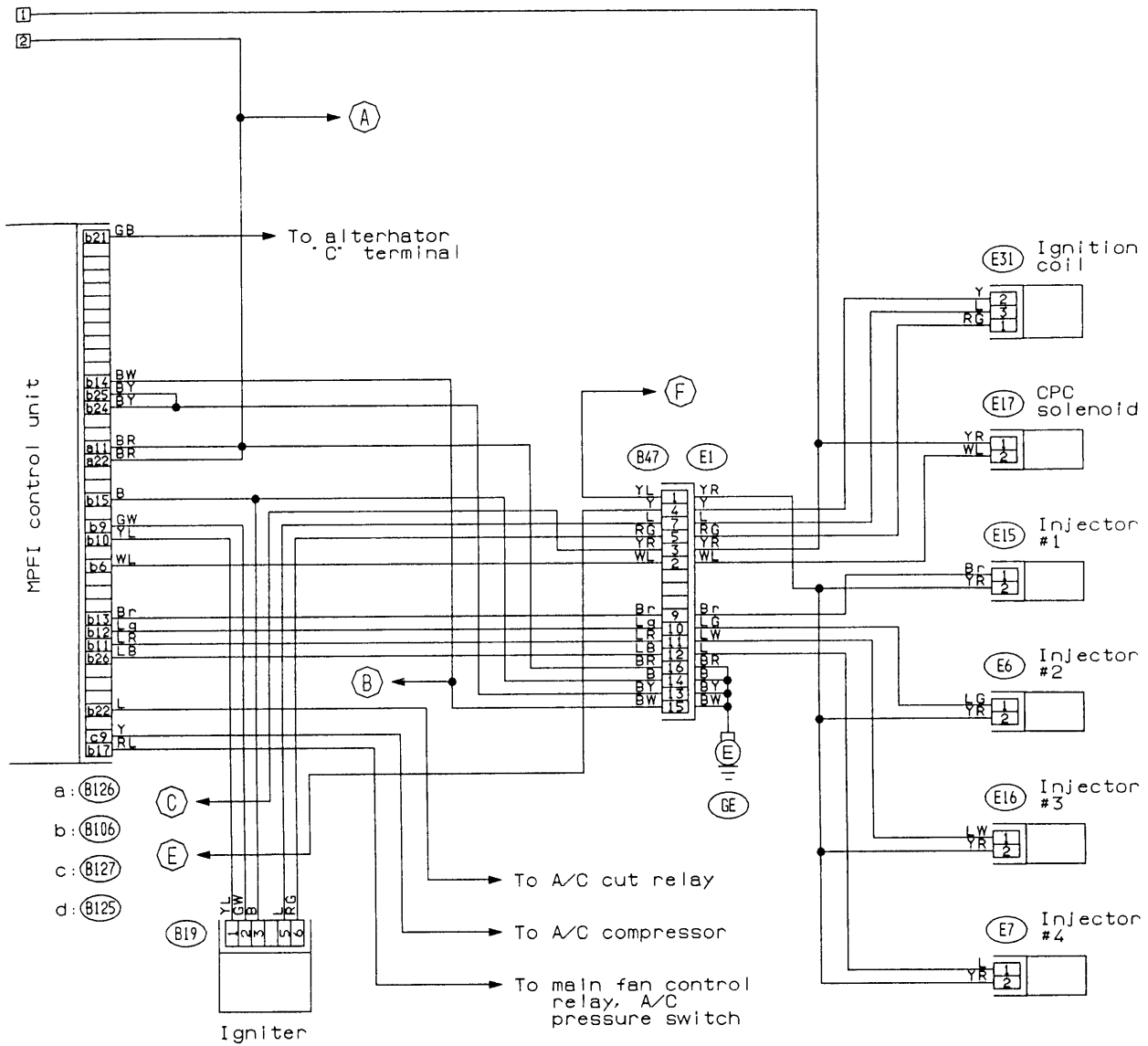


BR10-03B

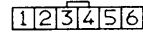


BR10-03C

Fig. 29-2



- (E6) (Gray)
- (E17) (Blue)
- (E7) (Gray)
- (E16) (Gray)
- (E15) (Gray)
- (E31) (Gray)
- (B19) (Gray)

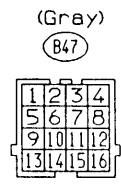
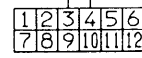
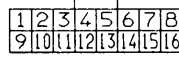
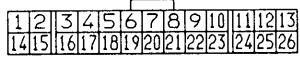
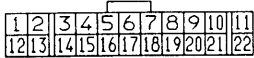


a: (B126) (Yellow)

b: (B106) (Yellow)

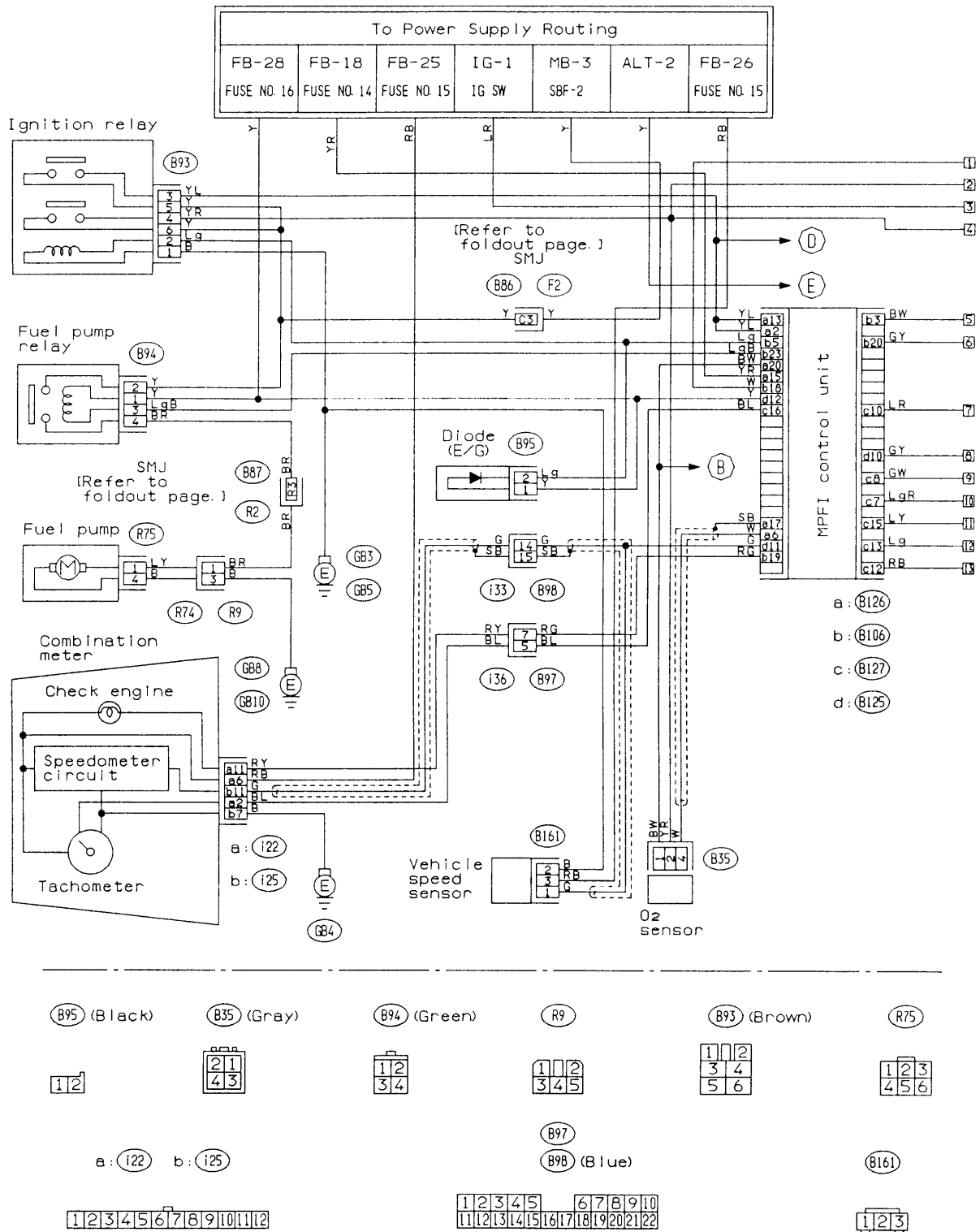
c: (B127) (Yellow)

d: (B125) (Yellow)



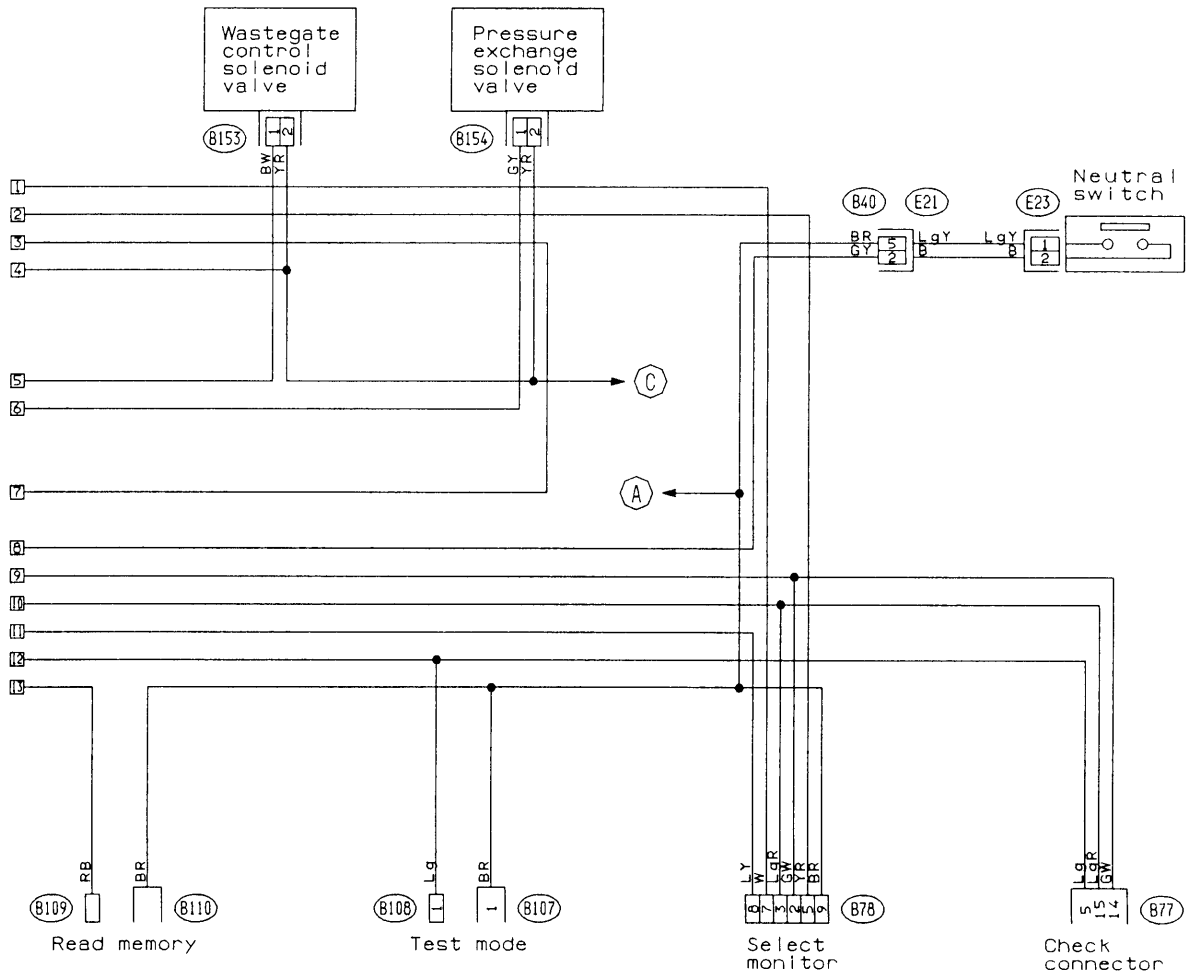
BR10-03D

MPFI MODEL (TURBO)



BR10-04A

Fig. 30-1



(B107) (Green)



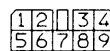
(E23) (Black)



(B108) (Green)



(B78) (Yellow)



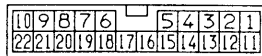
(B153) (Black)



(B40) (Gray)



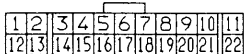
(B77) (Black)



(B154) (Brown)



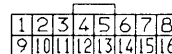
a: (B126) (Yellow)



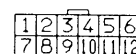
b: (B106) (Yellow)



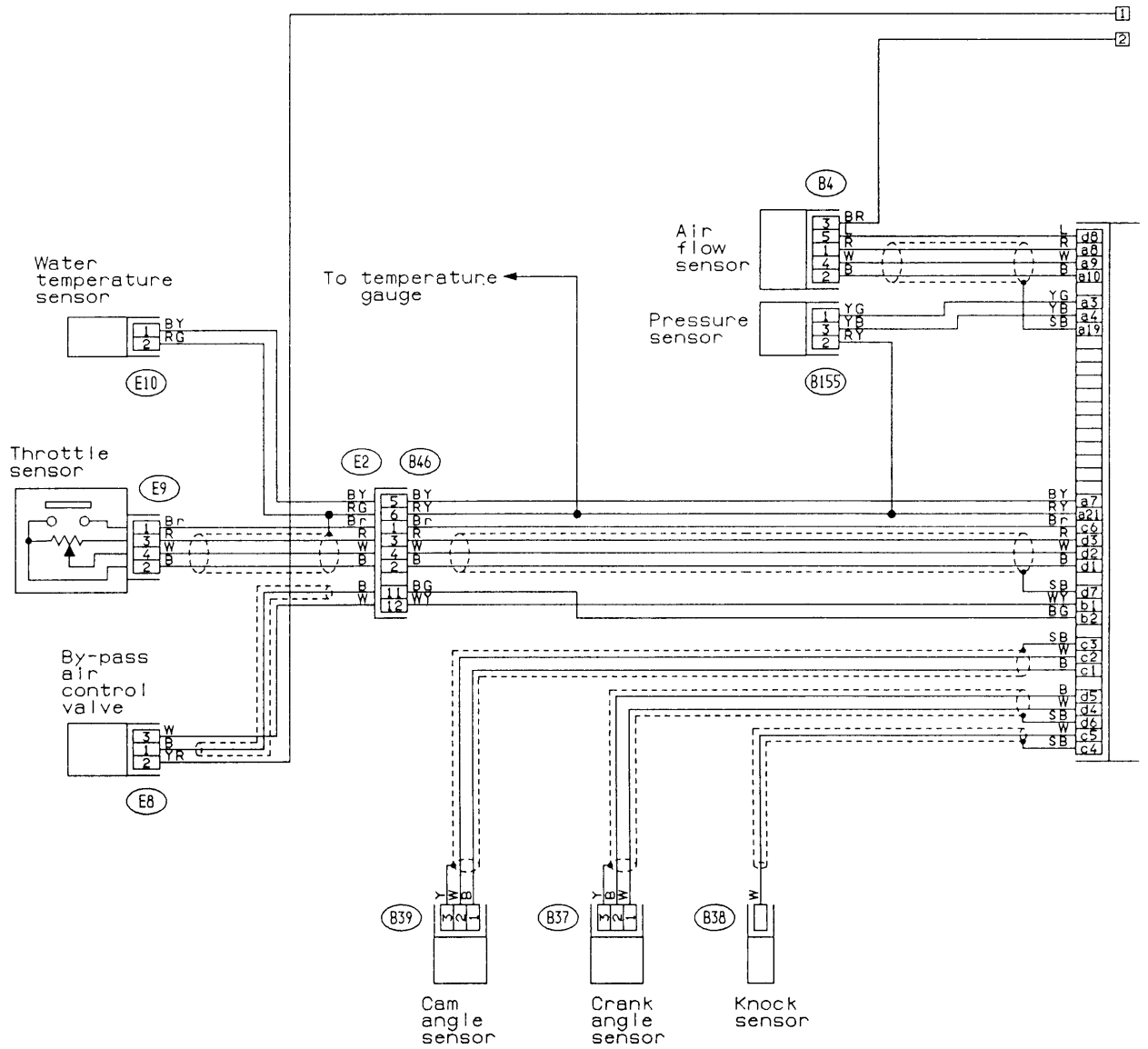
c: (B127) (Yellow)



d: (B125) (Yellow)



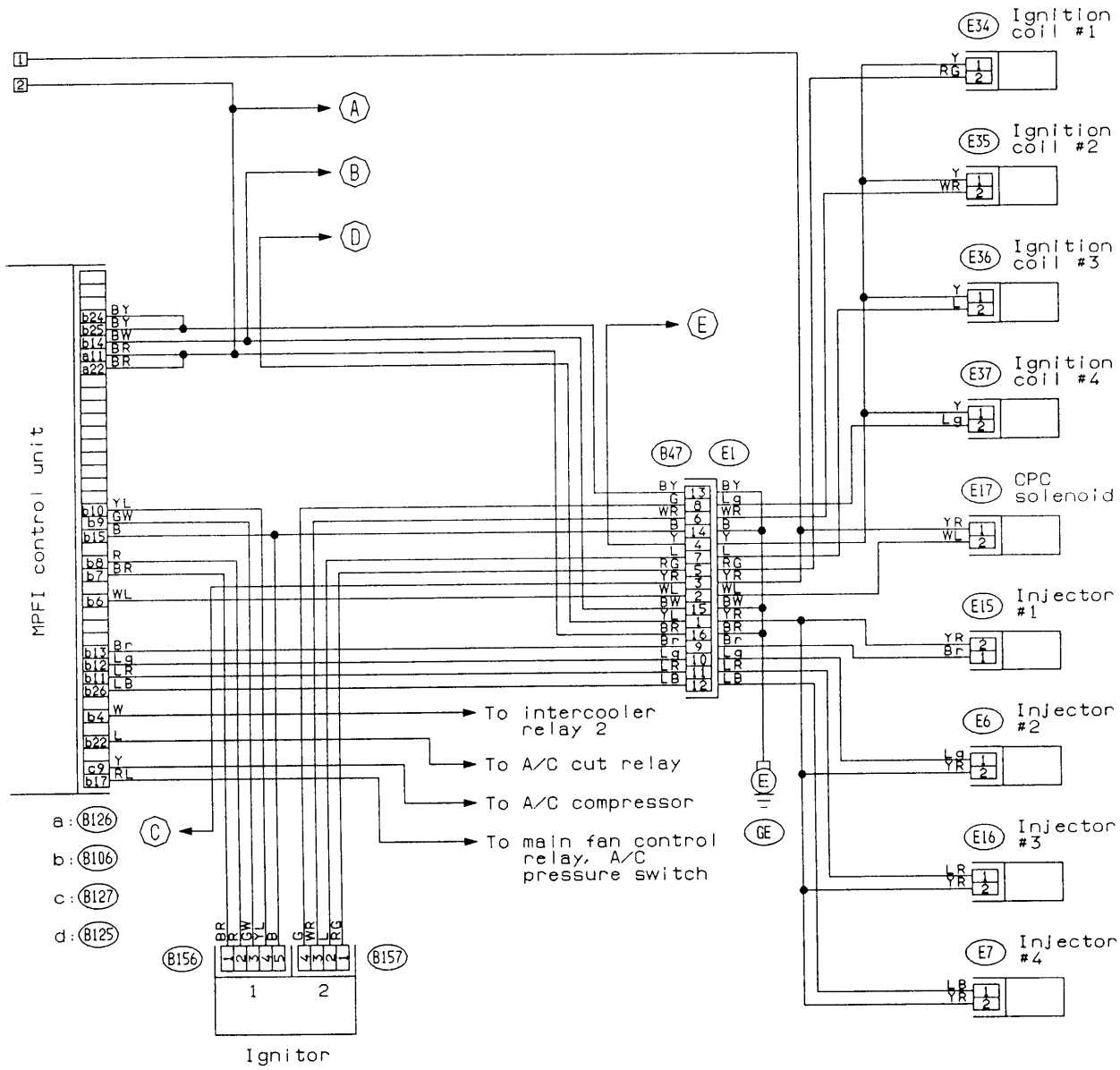
BR10-04B



- (E10) (Brown)
- (B37) (Gray)
- (B39) (Gray)
- (E9) (Gray)
- 1 2
- 1 2 3
- 1 2 3
- 1 2 3 4
- (B4) (Gray)
- (B46) (Gray)
- (B155) (Gray)
- 1 2 3 4 5
- 1 2 3 4
5 6 7 8
9 10 11 12
- 1 2
3

BR10-04C

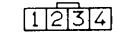
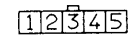
Fig. 30-2



- (E6) (Gray) (E17) (Blue) (E21) (Gray)
- (E7) (Gray) (E16) (Gray) (E15) (Gray)
- (E18) (Gray) (E19) (Gray) (E20) (Gray)

(B156) (Gray)

(B157) (Gray)



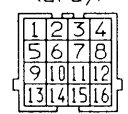
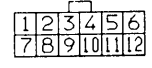
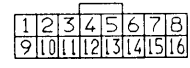
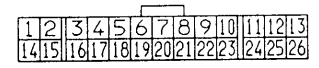
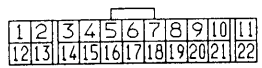
a: (B126) (Yellow)

b: (B106) (Yellow)

c: (B127) (Yellow)

d: (B125) (Yellow)

(B47) (Gray)



BR10-04D

SPFI MODEL

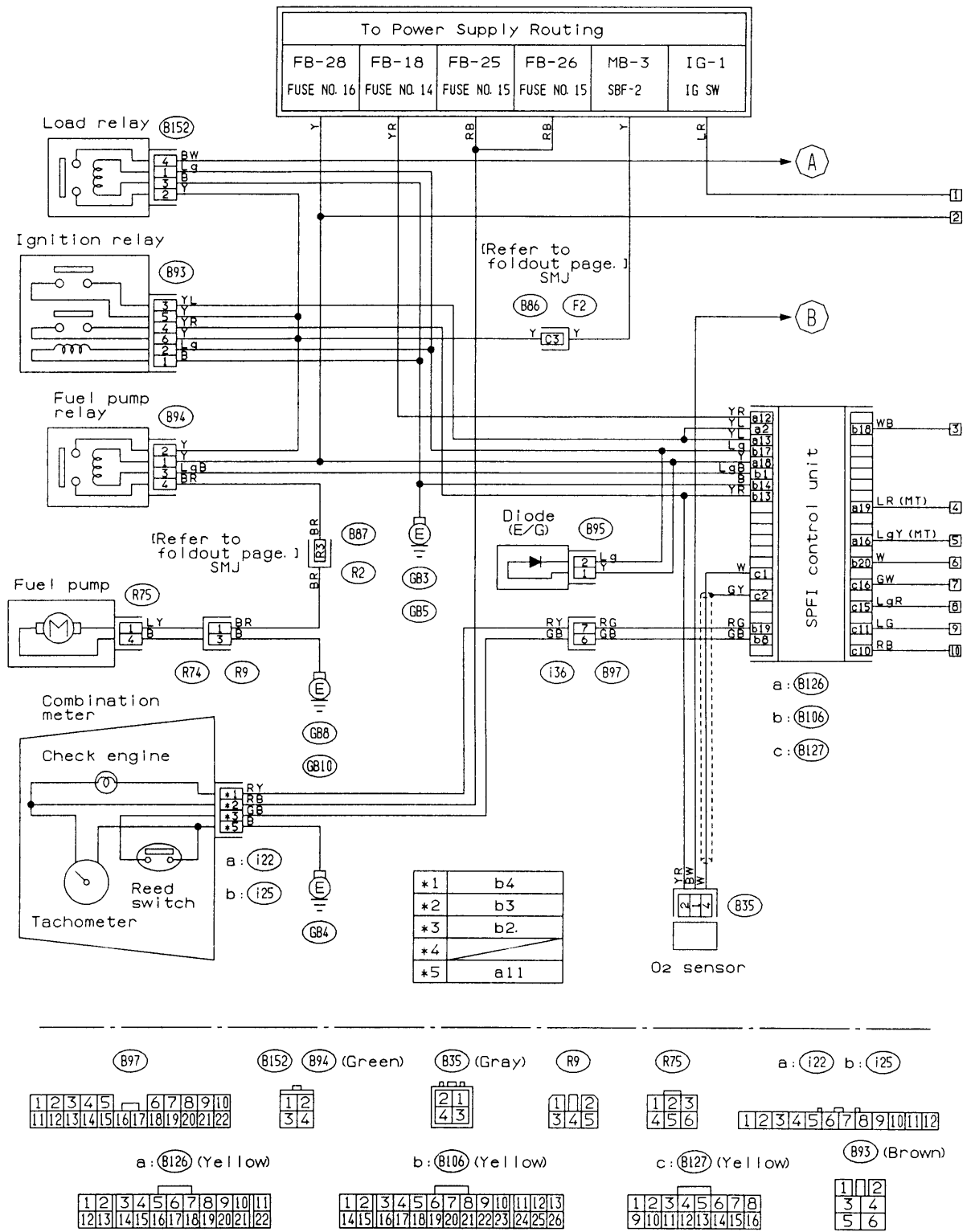
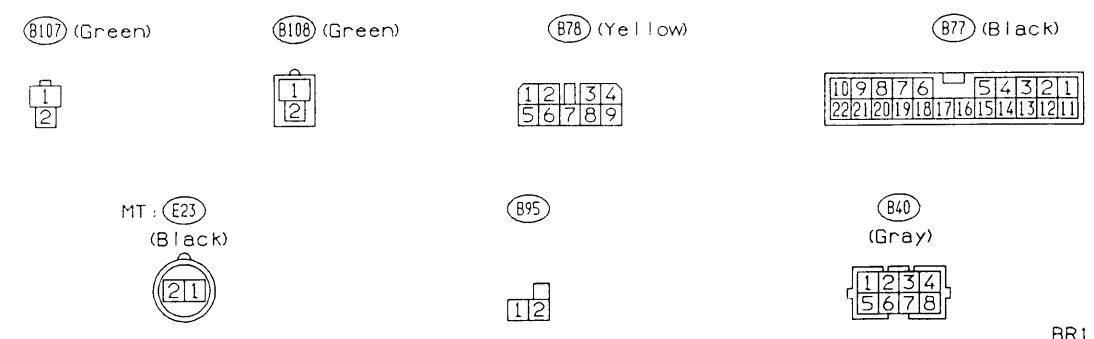
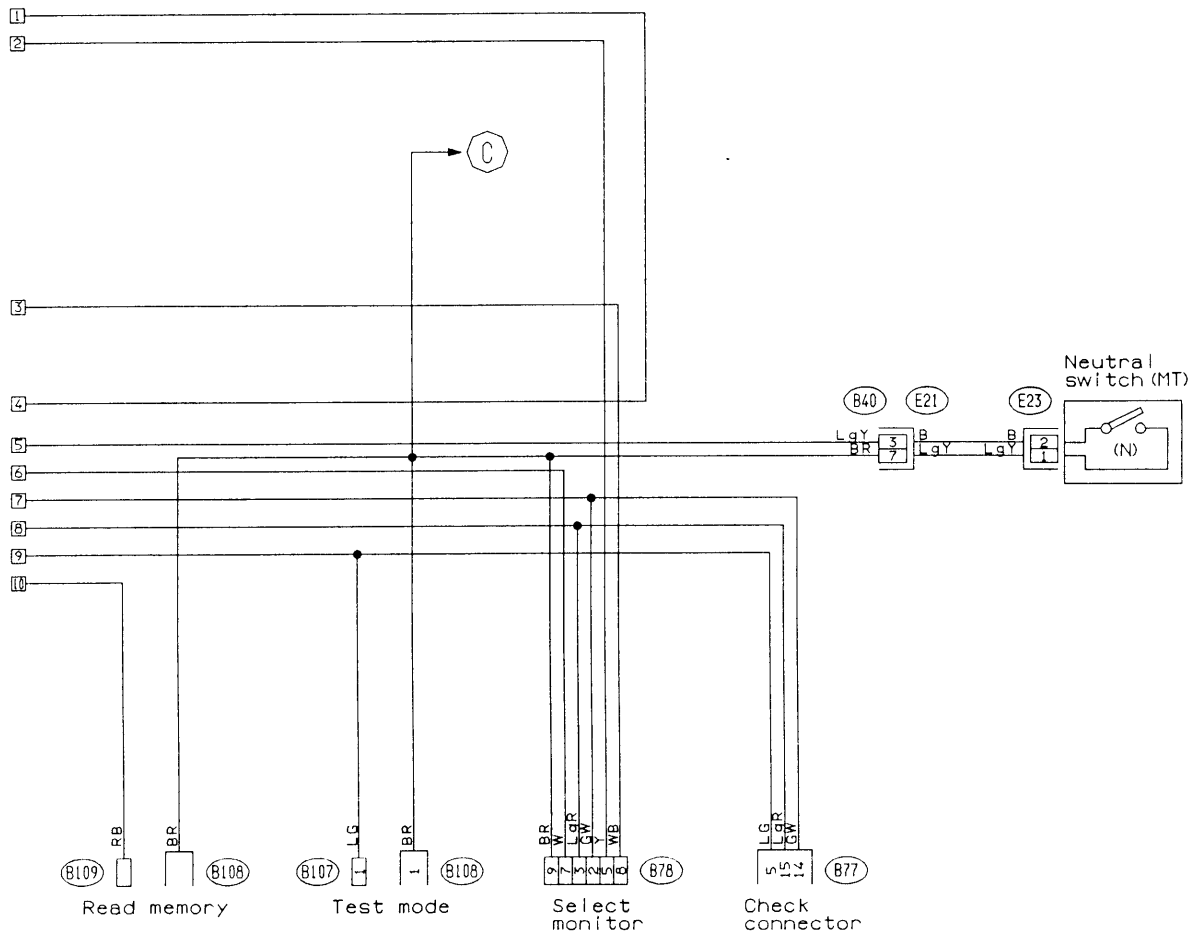
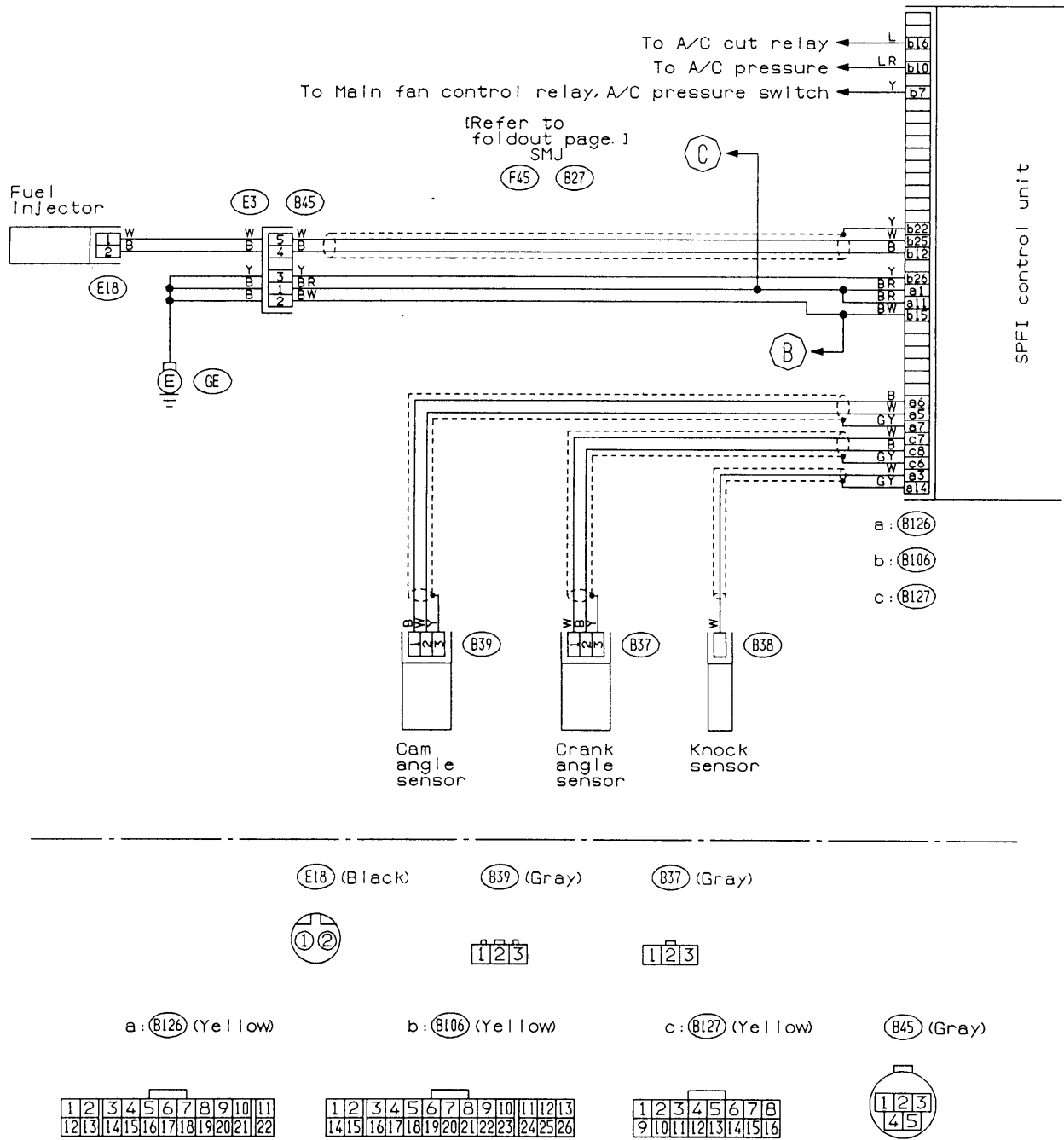


Fig. 31-1

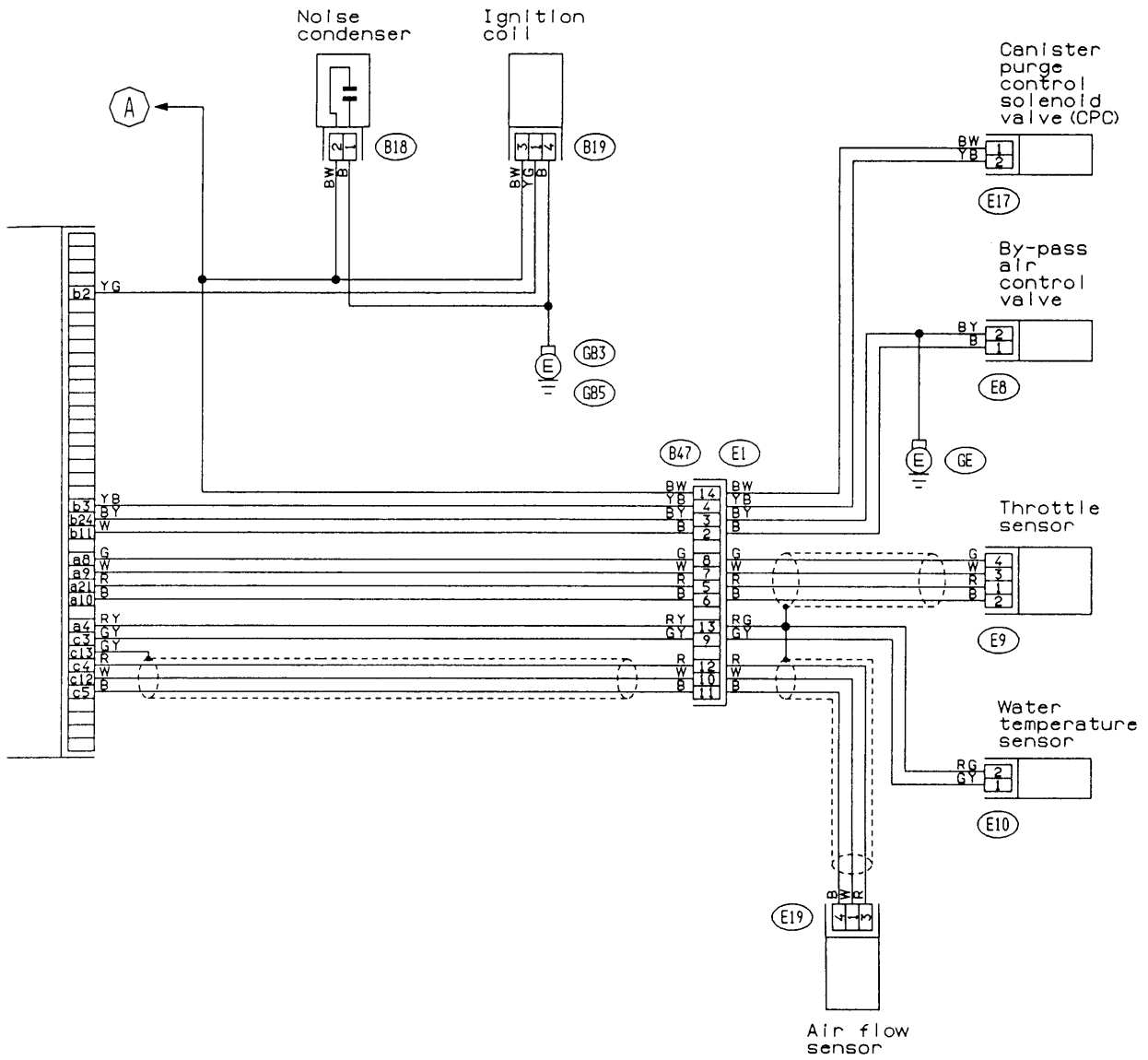


BR11-028

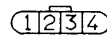


BR11-02C

Fig. 31-2



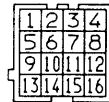
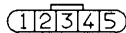
(B18) (Black) (E10) (Brown) (E17) (Blue) (E8) (Gray) (E9) (Gray)



(B19) (Gray)

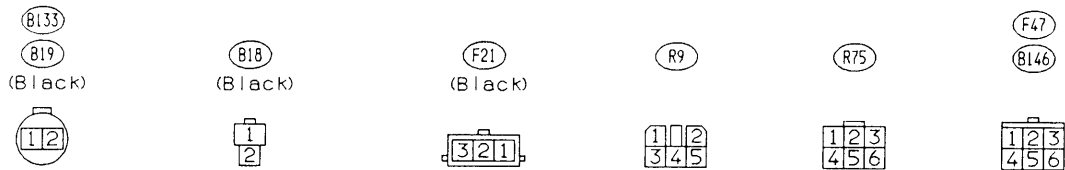
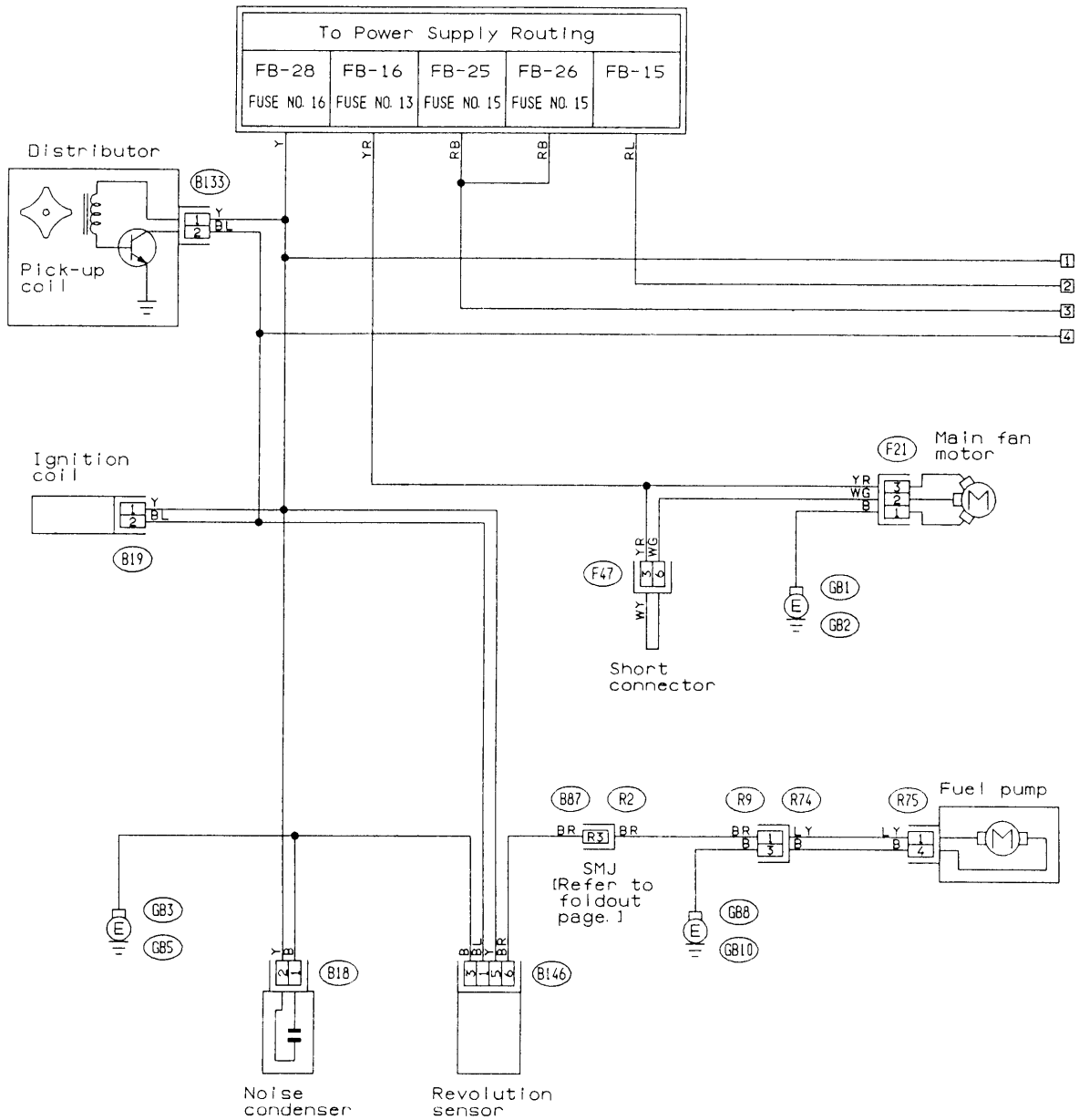
(E19) (Gray)

(B47) (Gray)



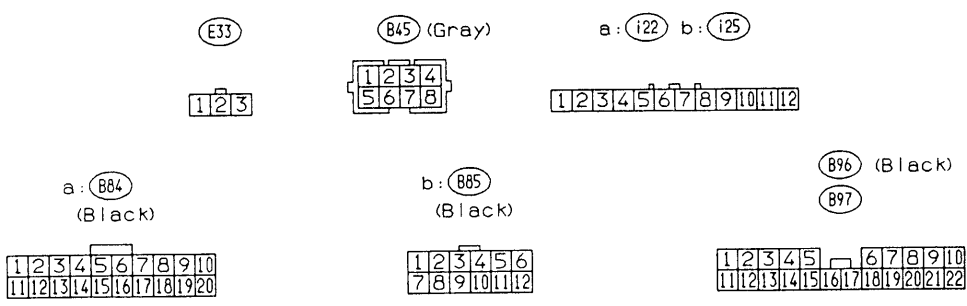
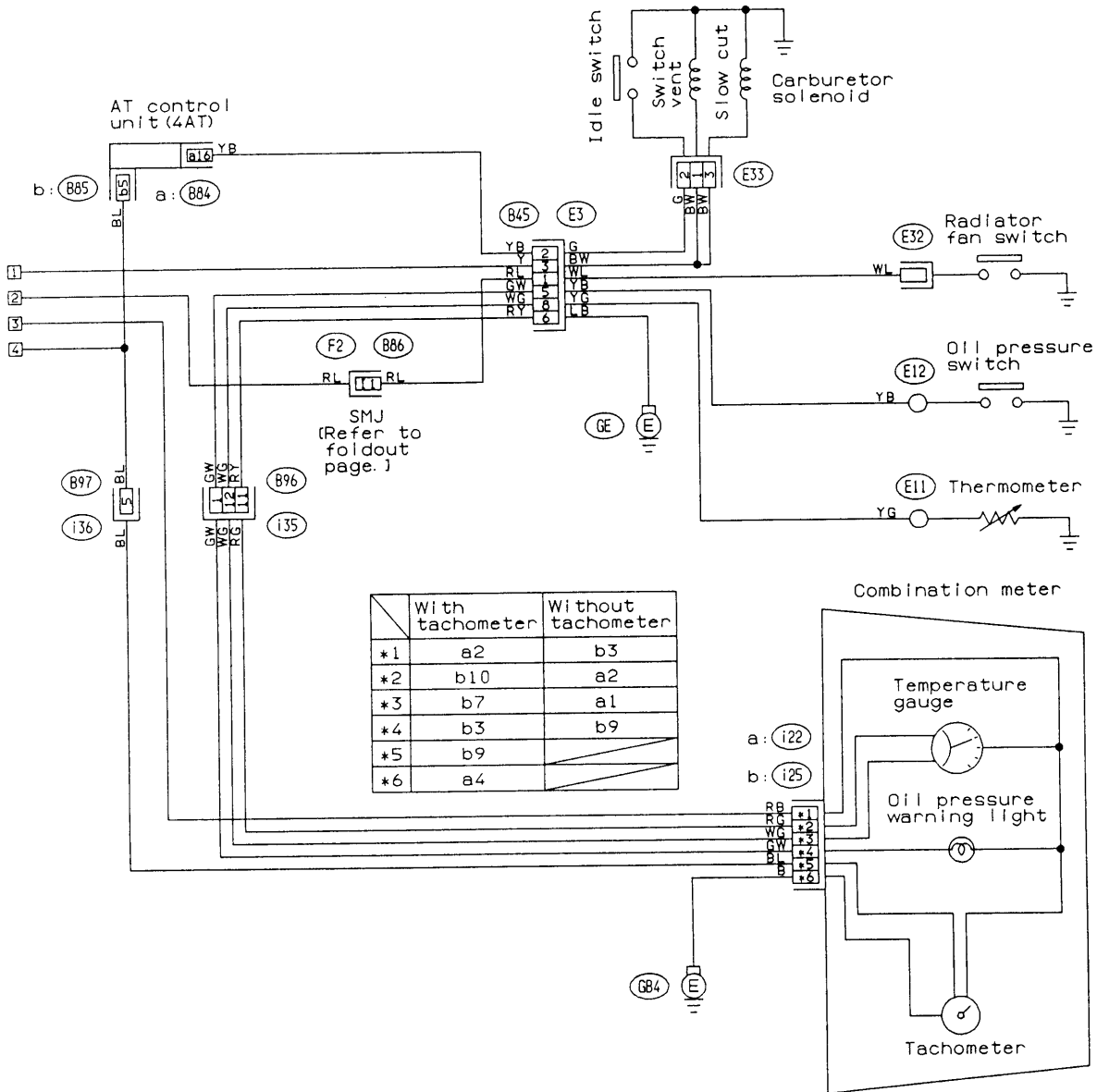
BR11-02D

CARBURETOR MODEL



BR09-03A

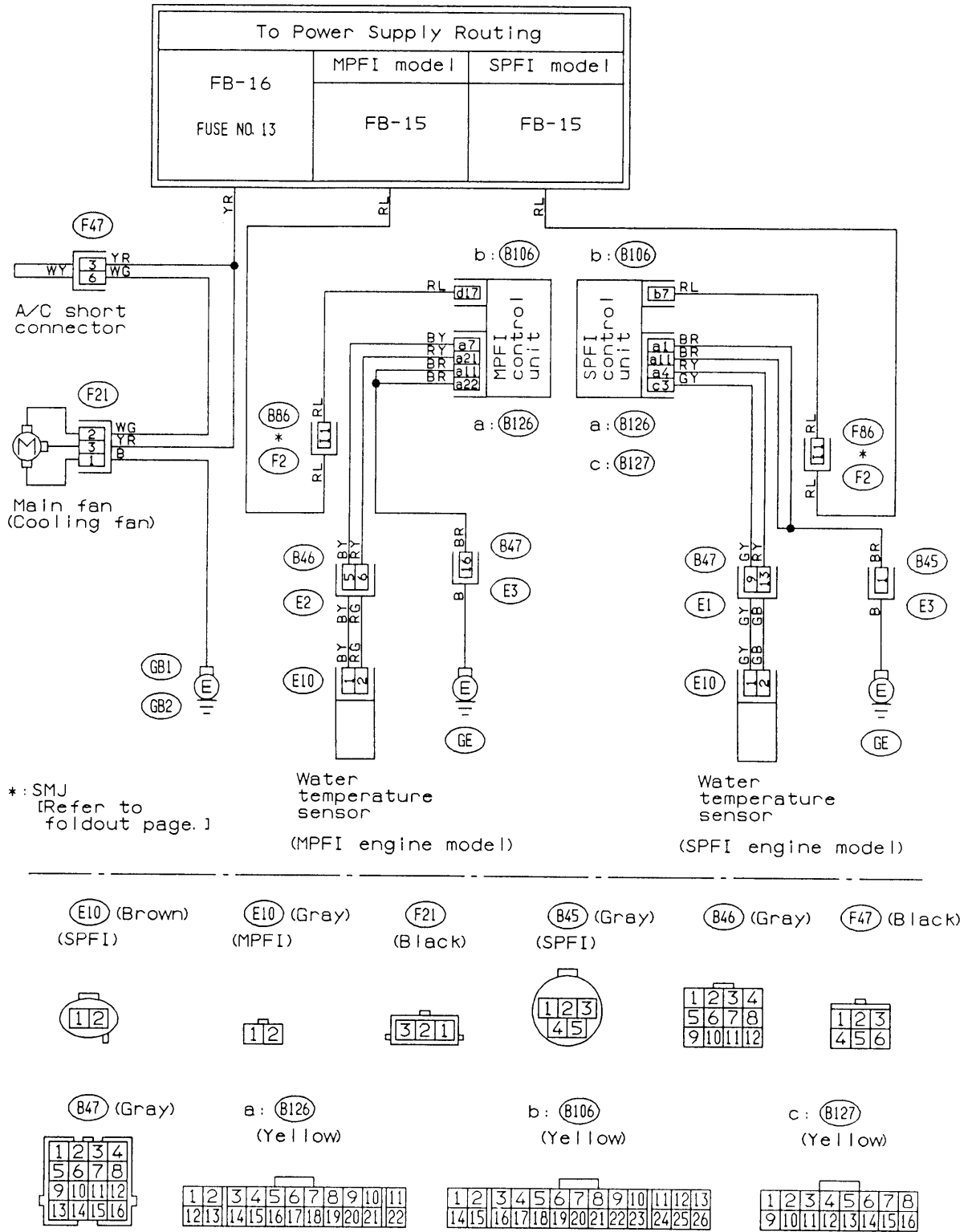
Fig. 32



BR09-03B

5. COOLING FAN

MPFI/SPFI MODEL (Refer to "Engine Electrical" for carburetor models.)

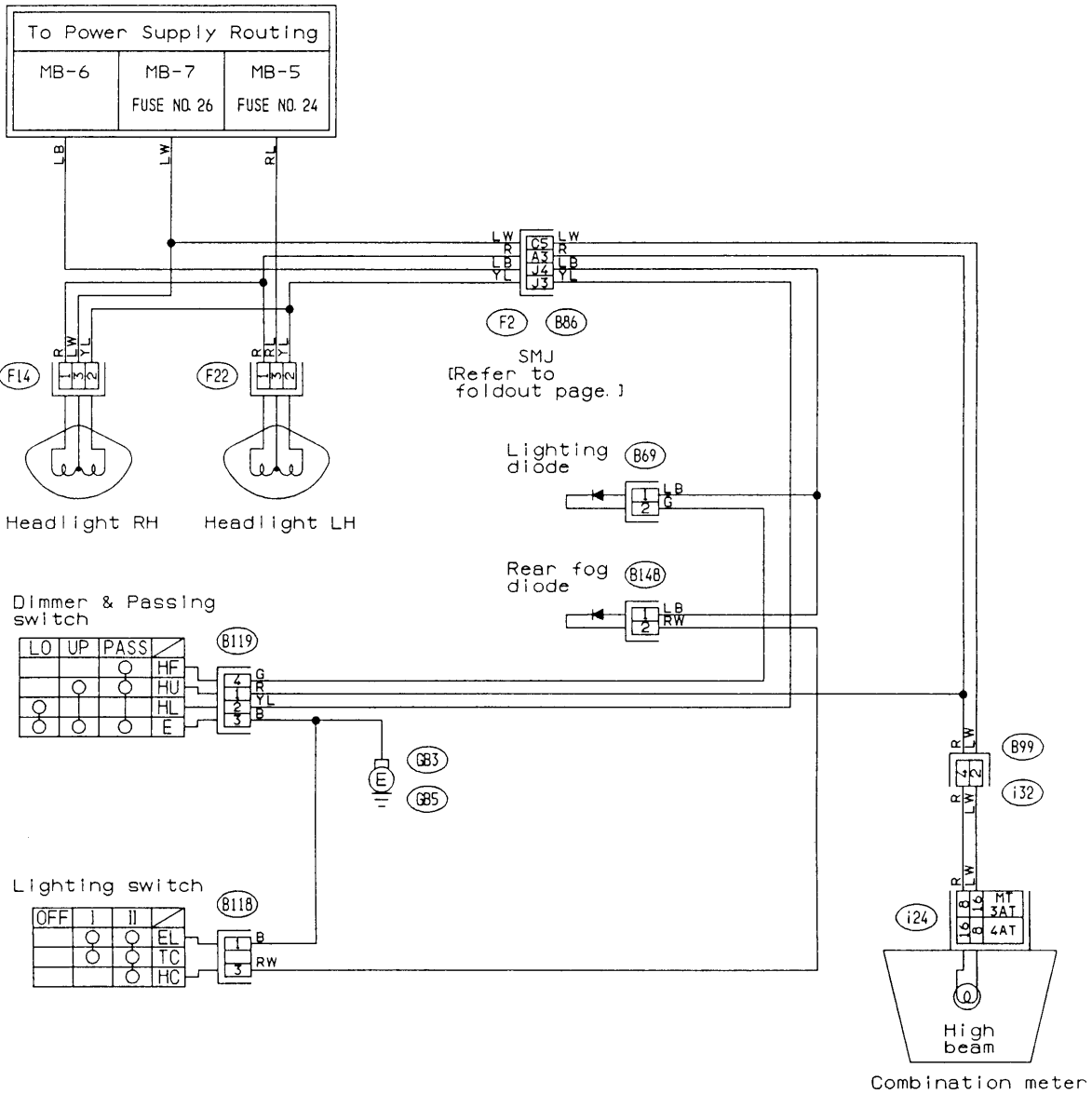


BR14-03

Fig. 33

6-1. LIGHTING (HEADLIGHTS)

AUSTRALIA MODEL



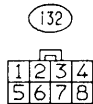
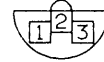
(B148) (Black)

(B69) (Black)

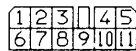


(F22) (Black)

(F14) (Black)



(B118) (Black)



(B124)

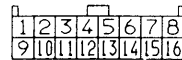


Fig. 34

BR20-03

OTHER MODELS

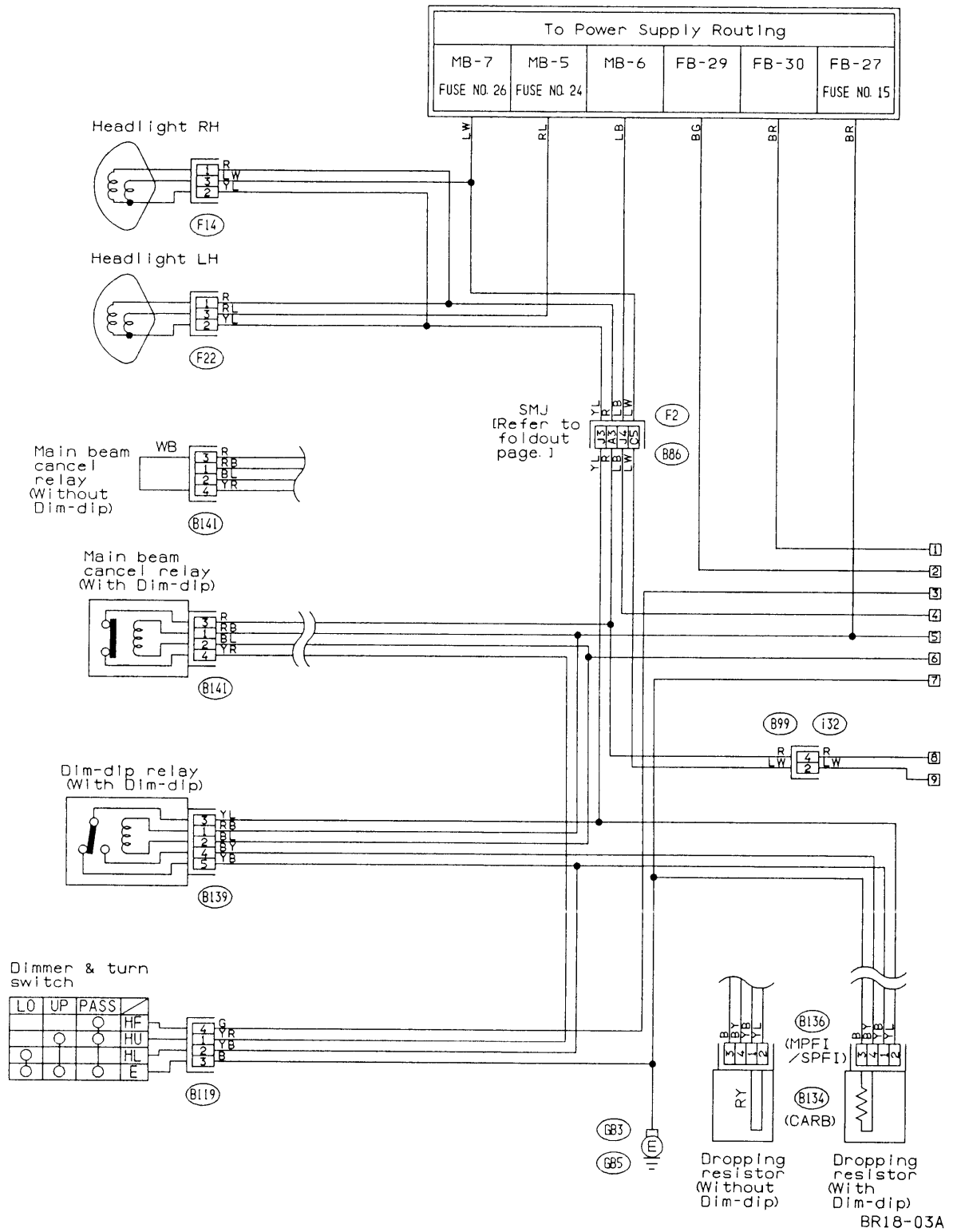
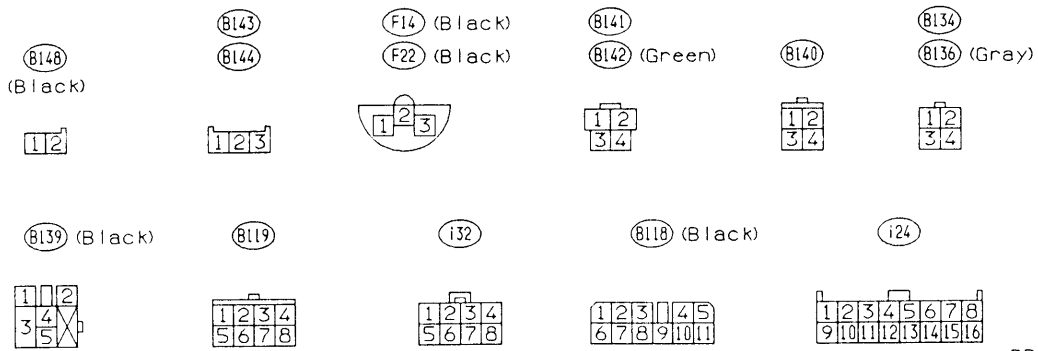
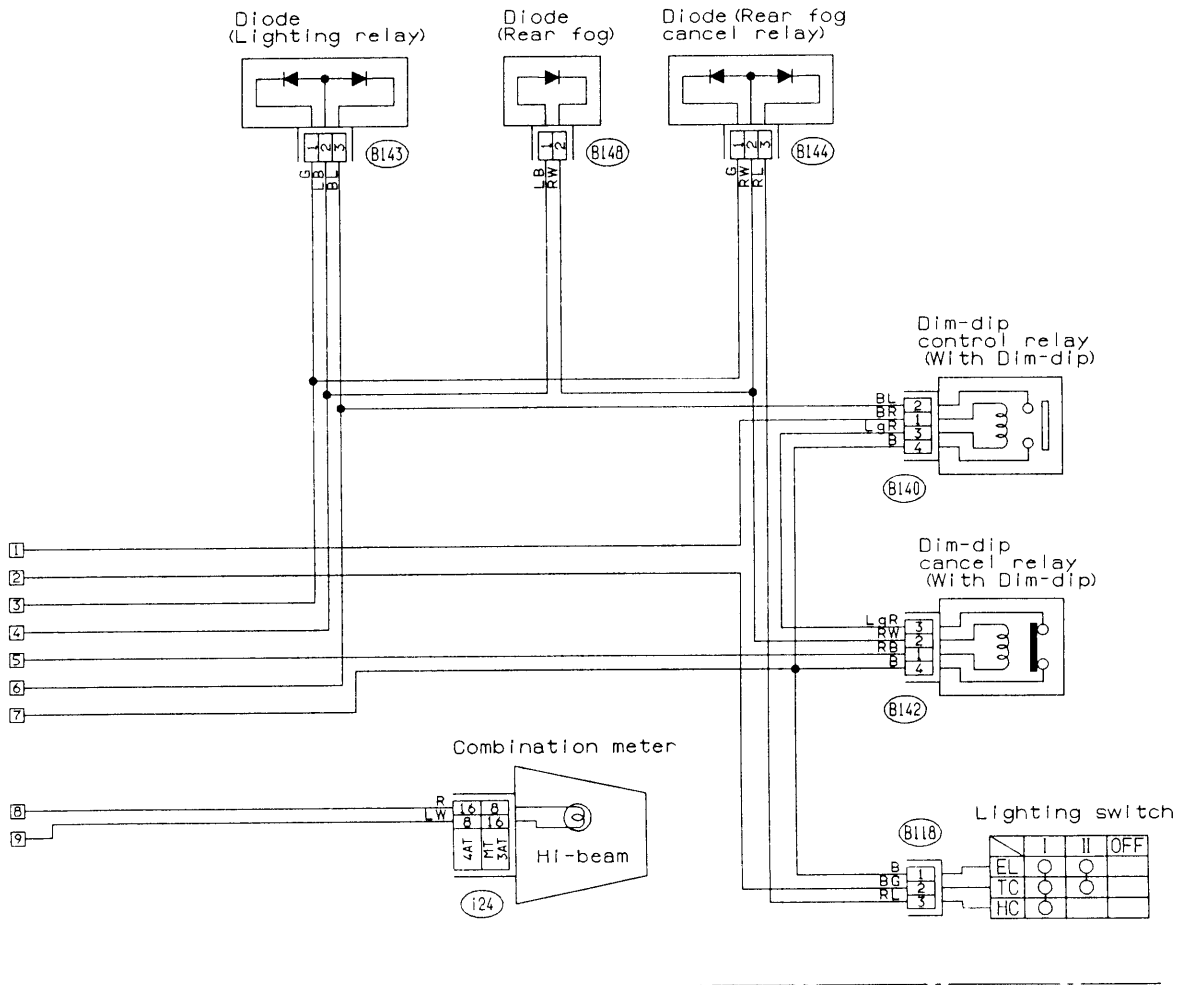
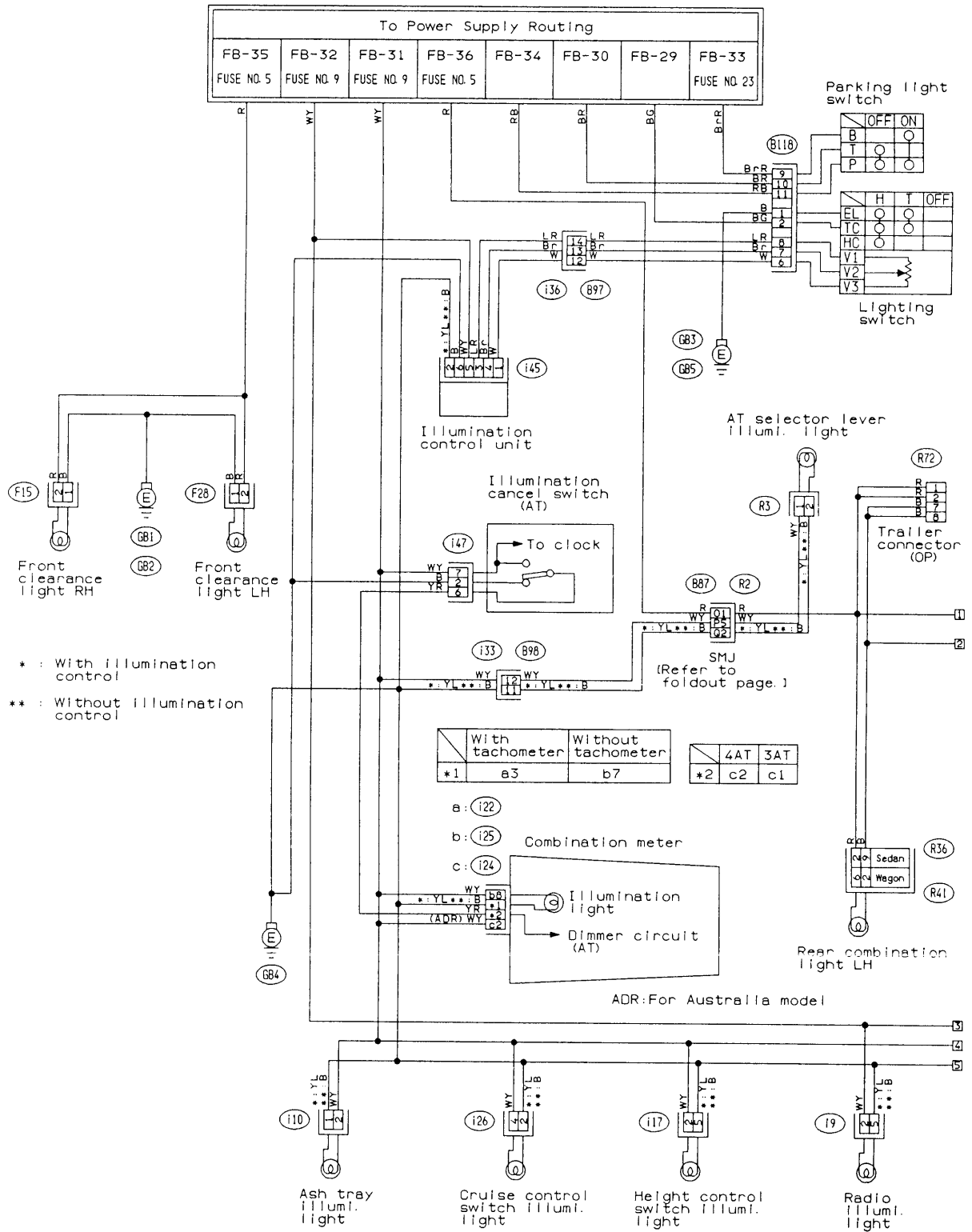


Fig. 35



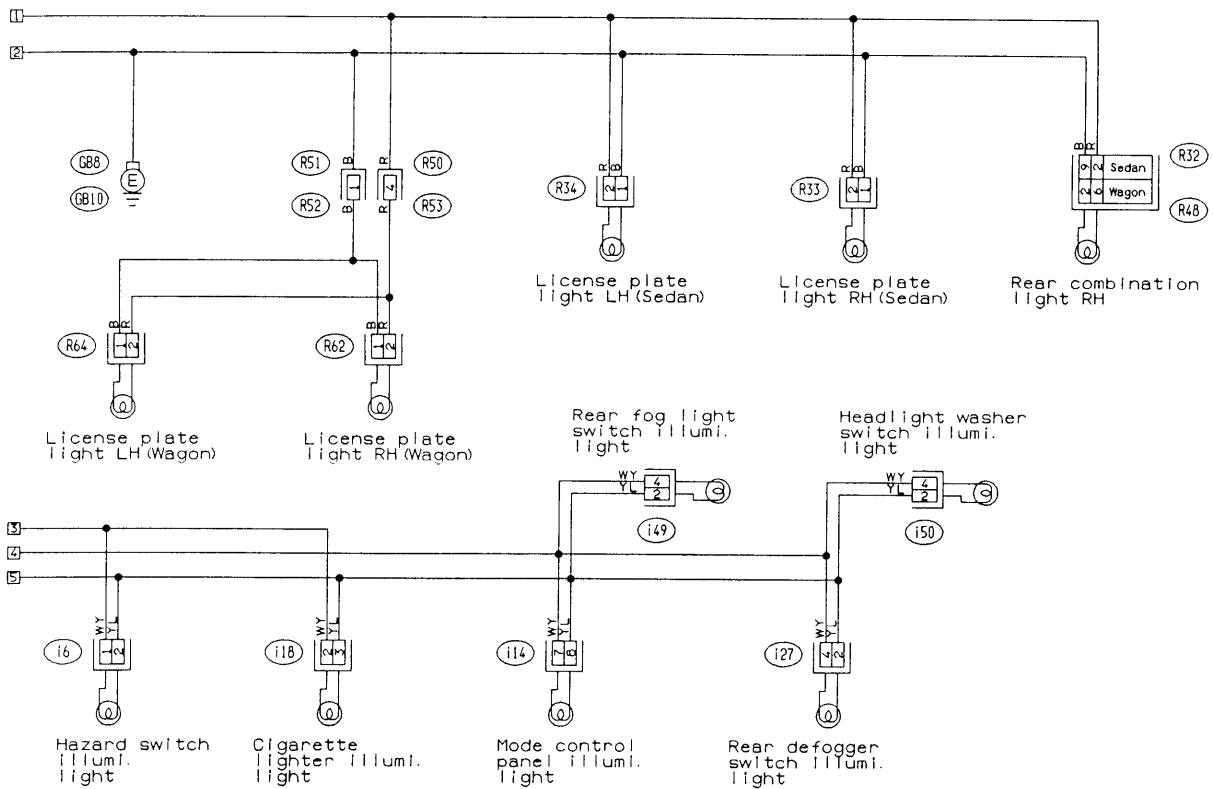
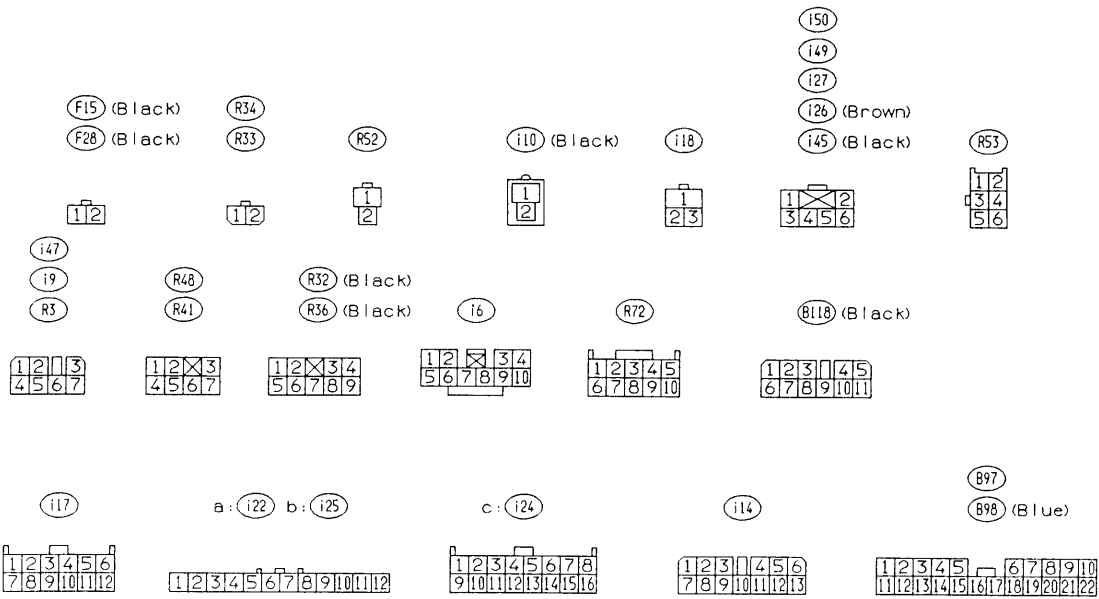
BR18-03B

6-2. LIGHTING (TAIL•ILLUMINATION•etc.)



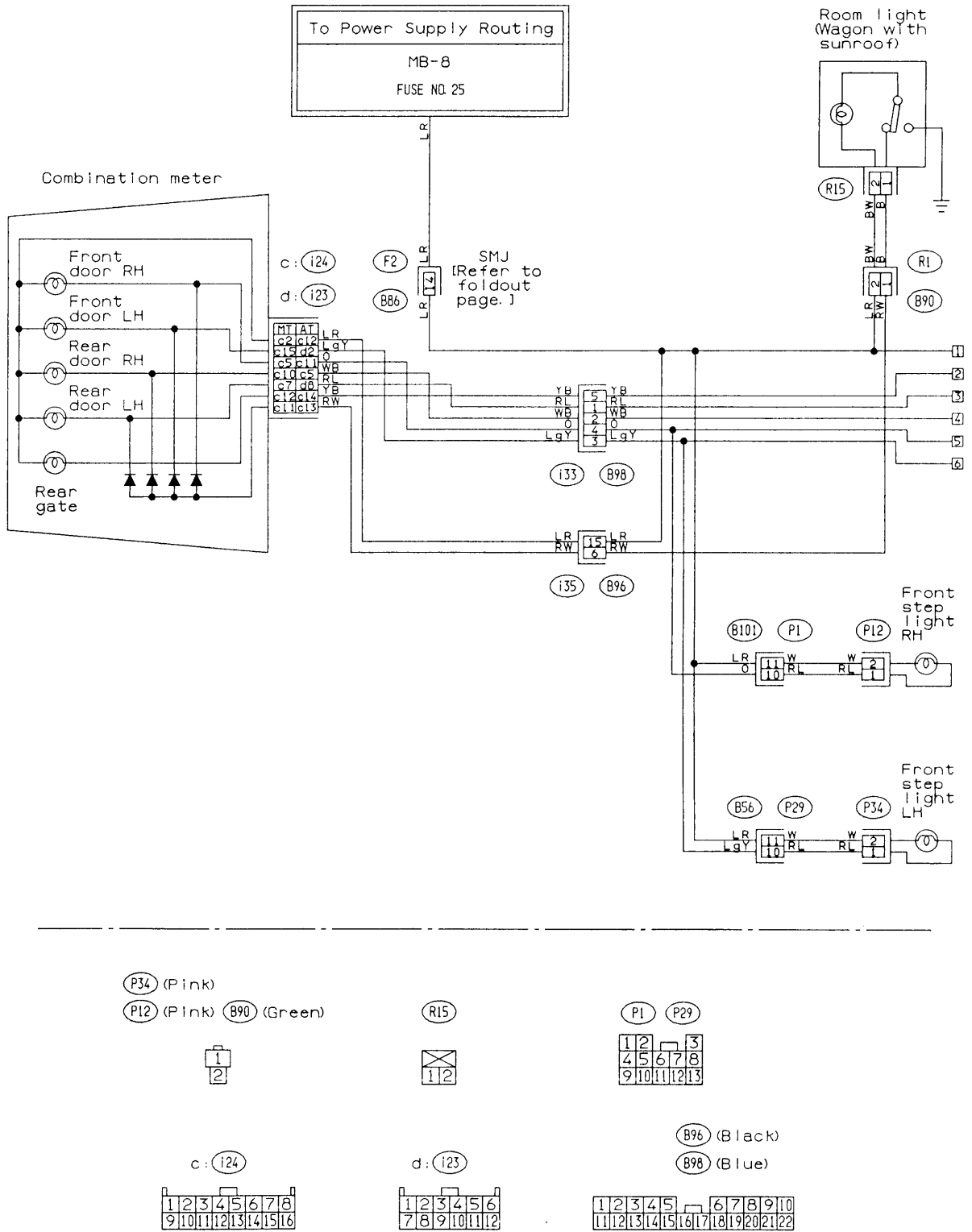
BR21-03A

Fig. 36



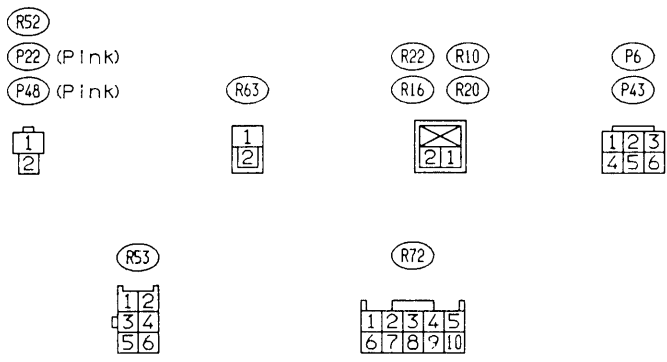
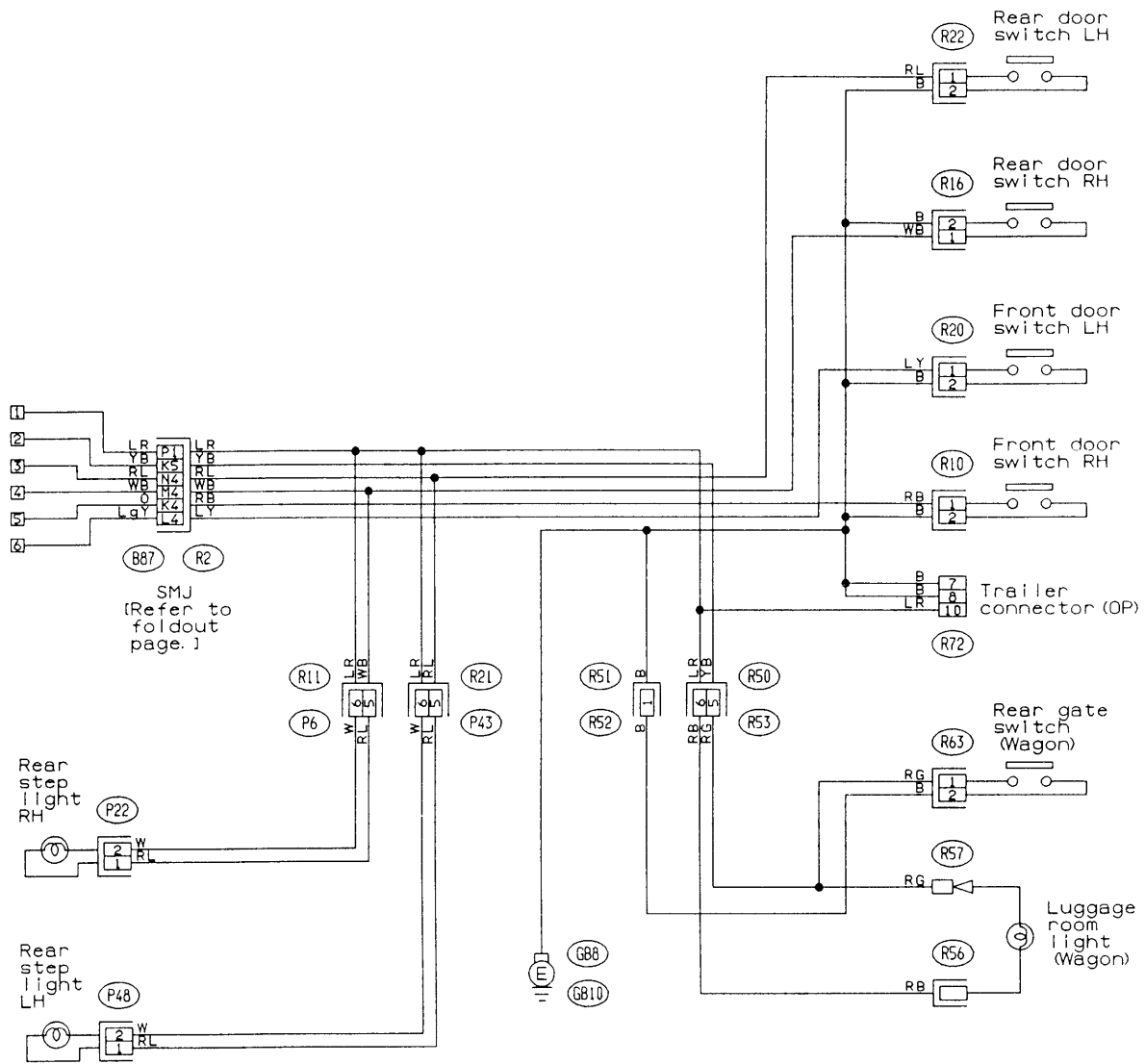
BR21-03B

7. ROOM LIGHT AND DOOR SWITCH
With Step Light



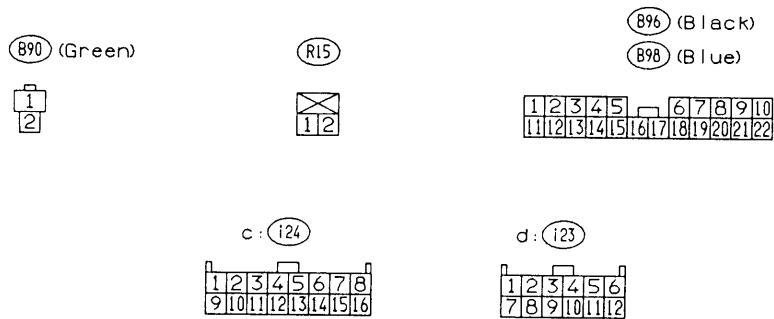
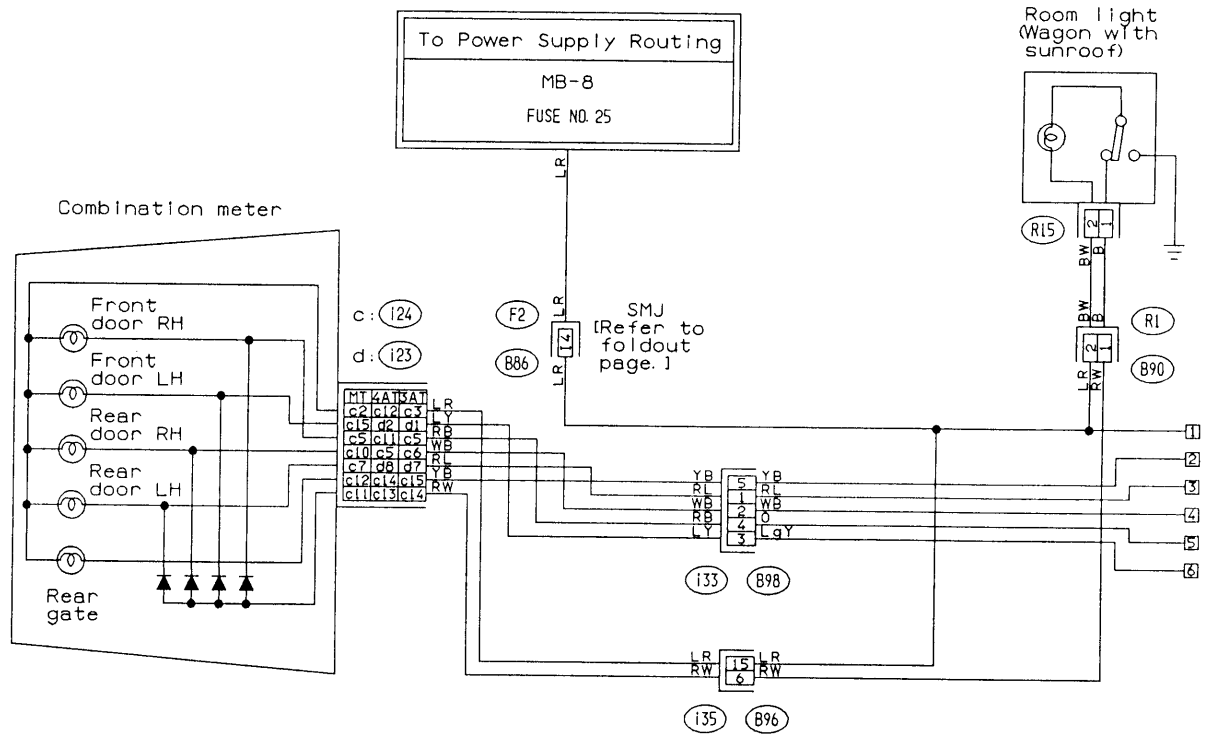
BR23-03A

Fig. 37-1



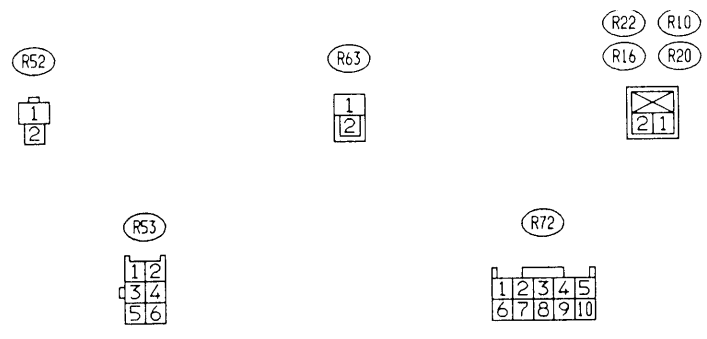
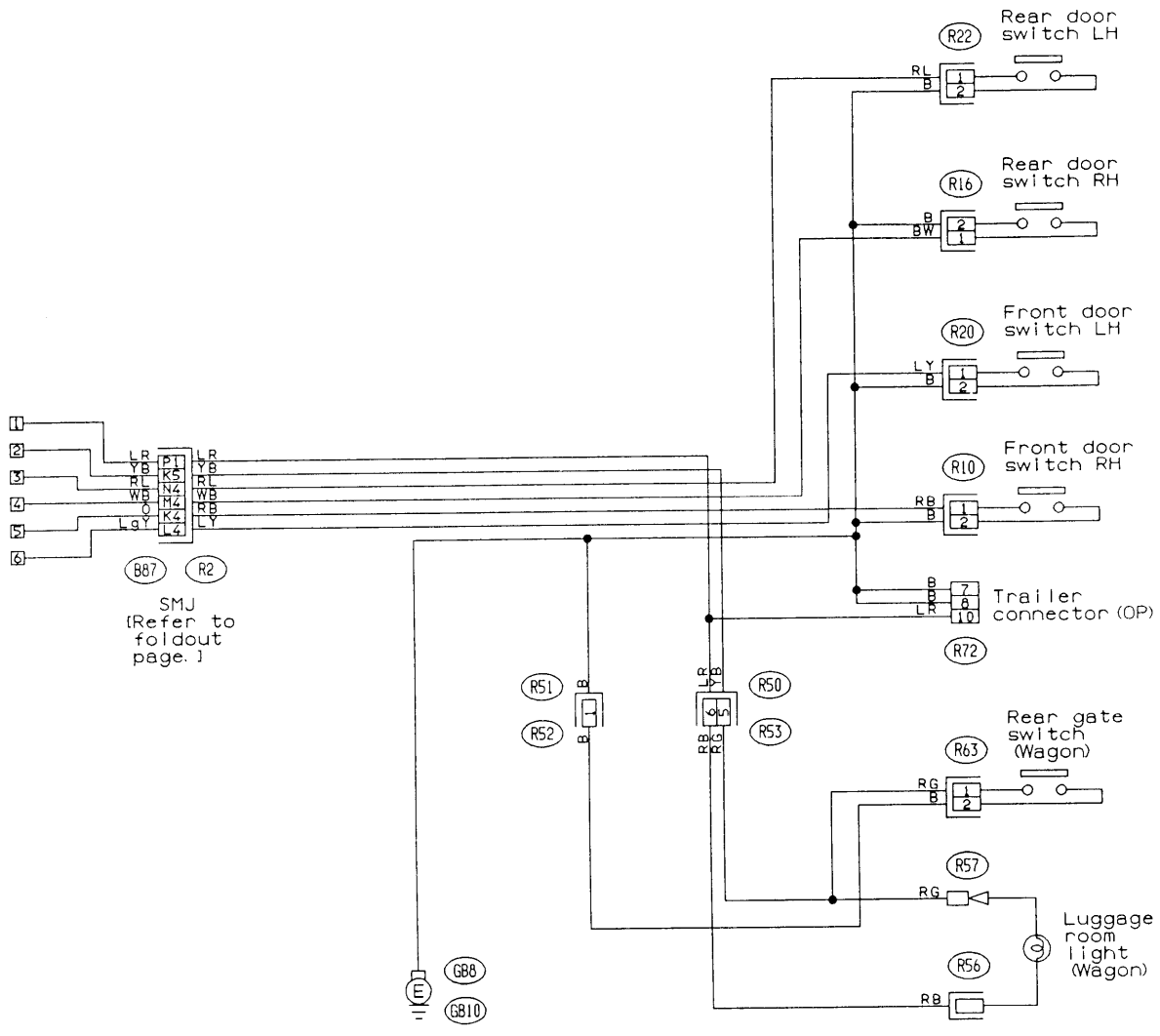
BR23-03B

Without Step Light



BR24-03A

Fig. 37-2



BR24-03B

8. STOP LIGHT

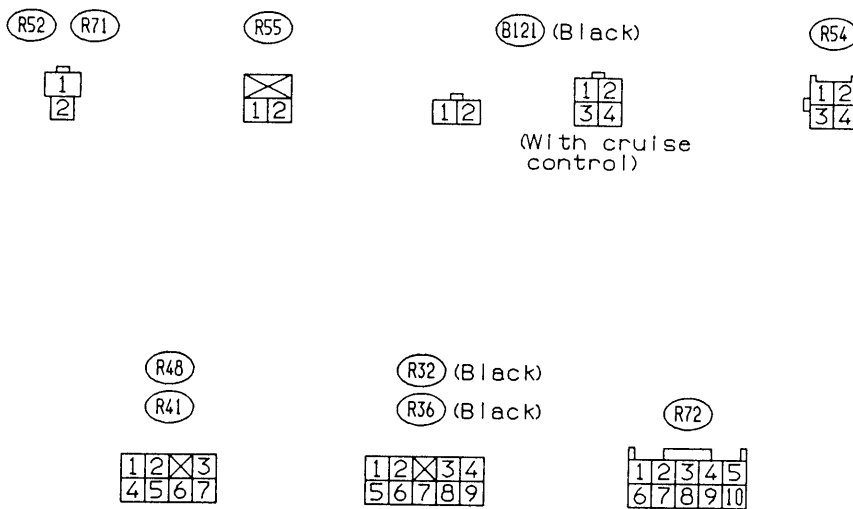
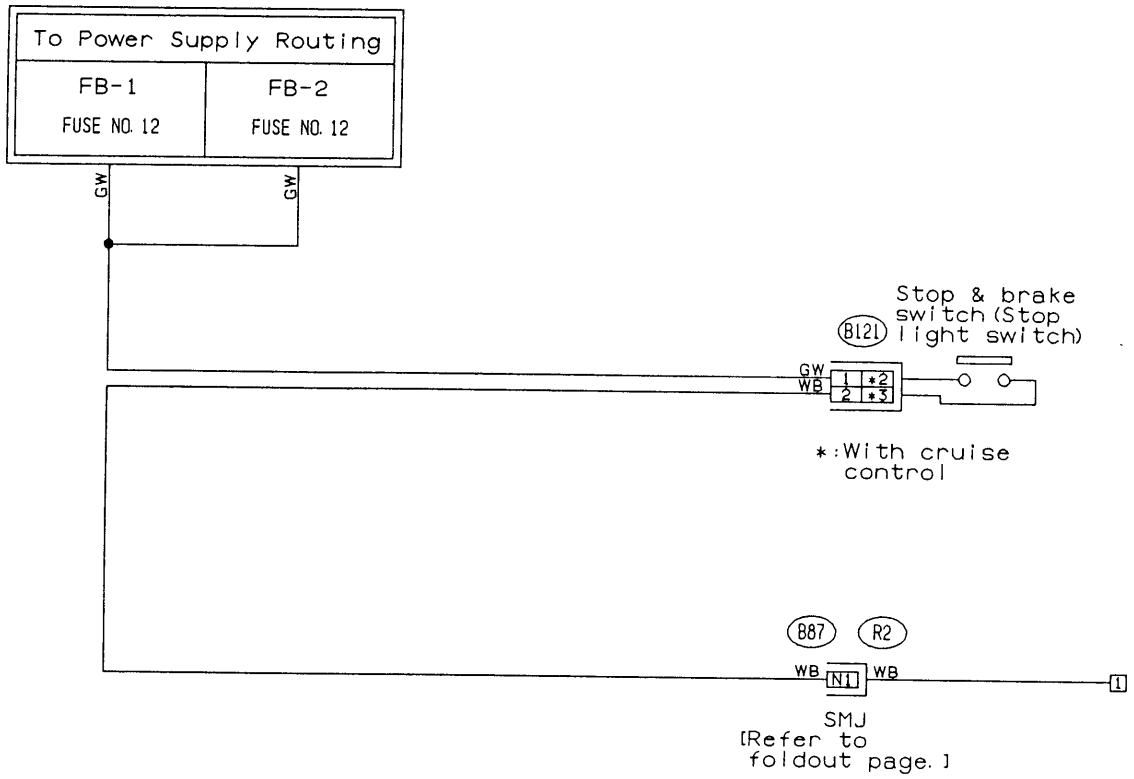
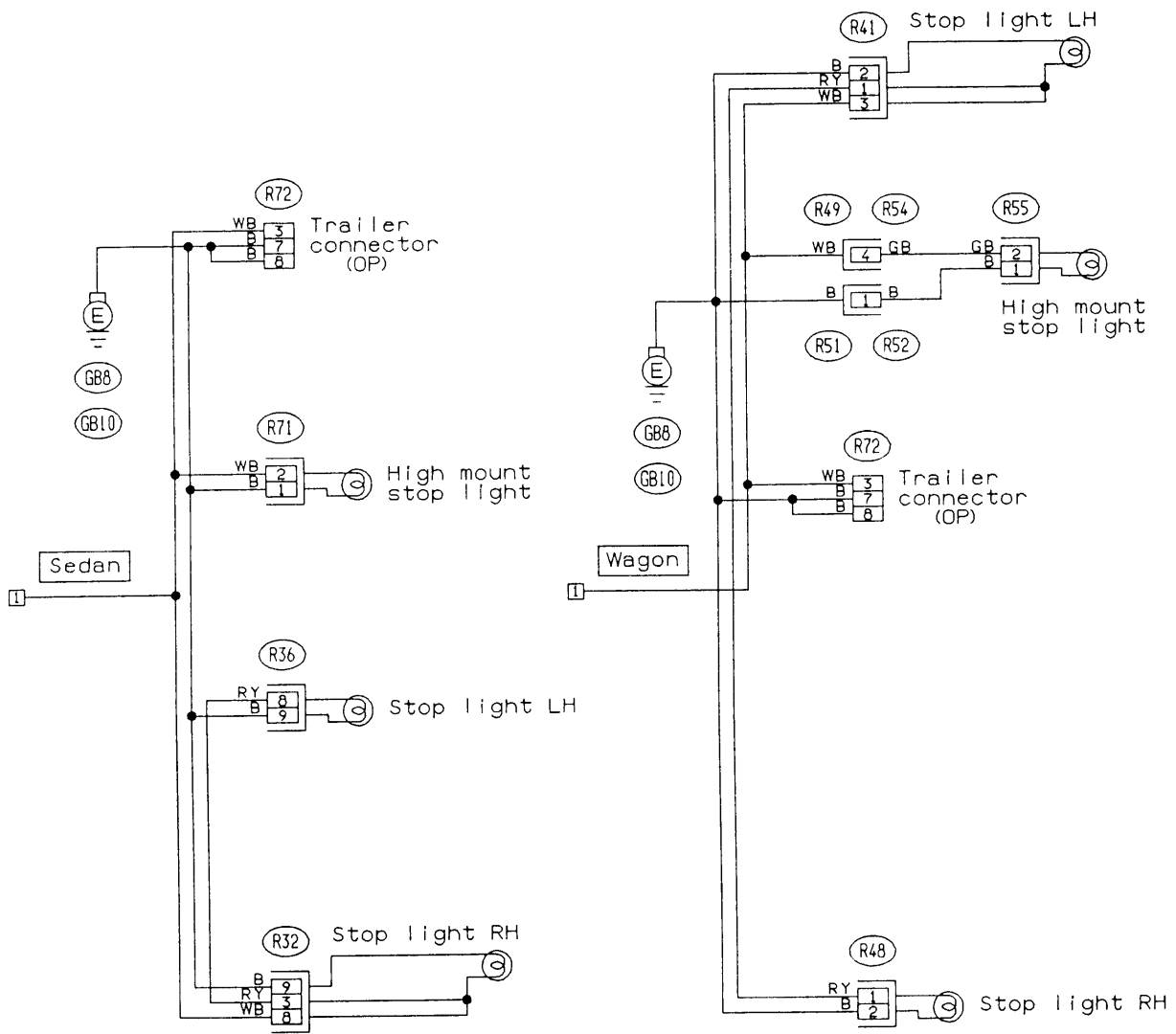


Fig. 38

BR25-02A



BR25-02B

9. TURN SIGNAL AND HAZARD

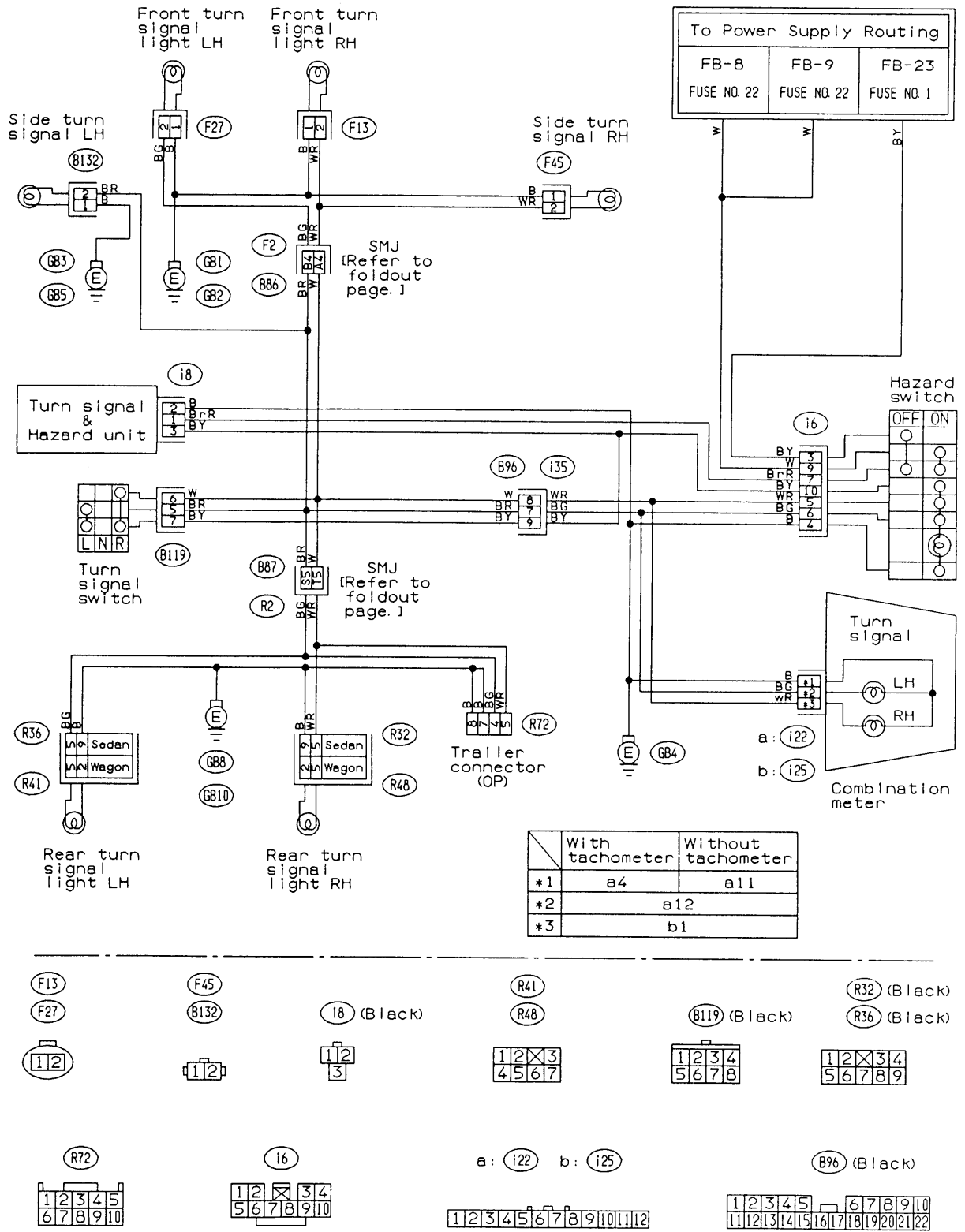
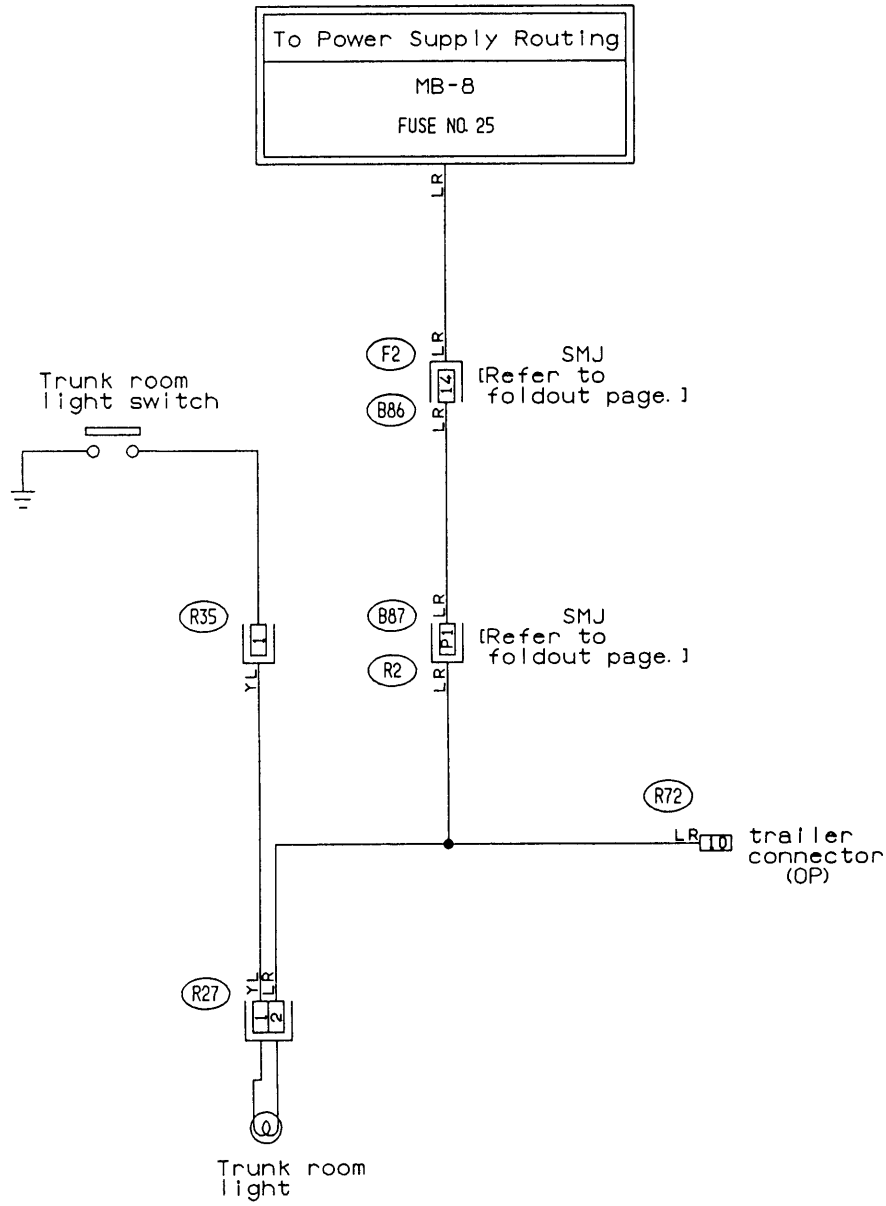


Fig. 39

BR26-02

10. TRUNK ROOM LIGHT



R27 (Black)



R35



R72

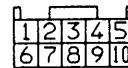
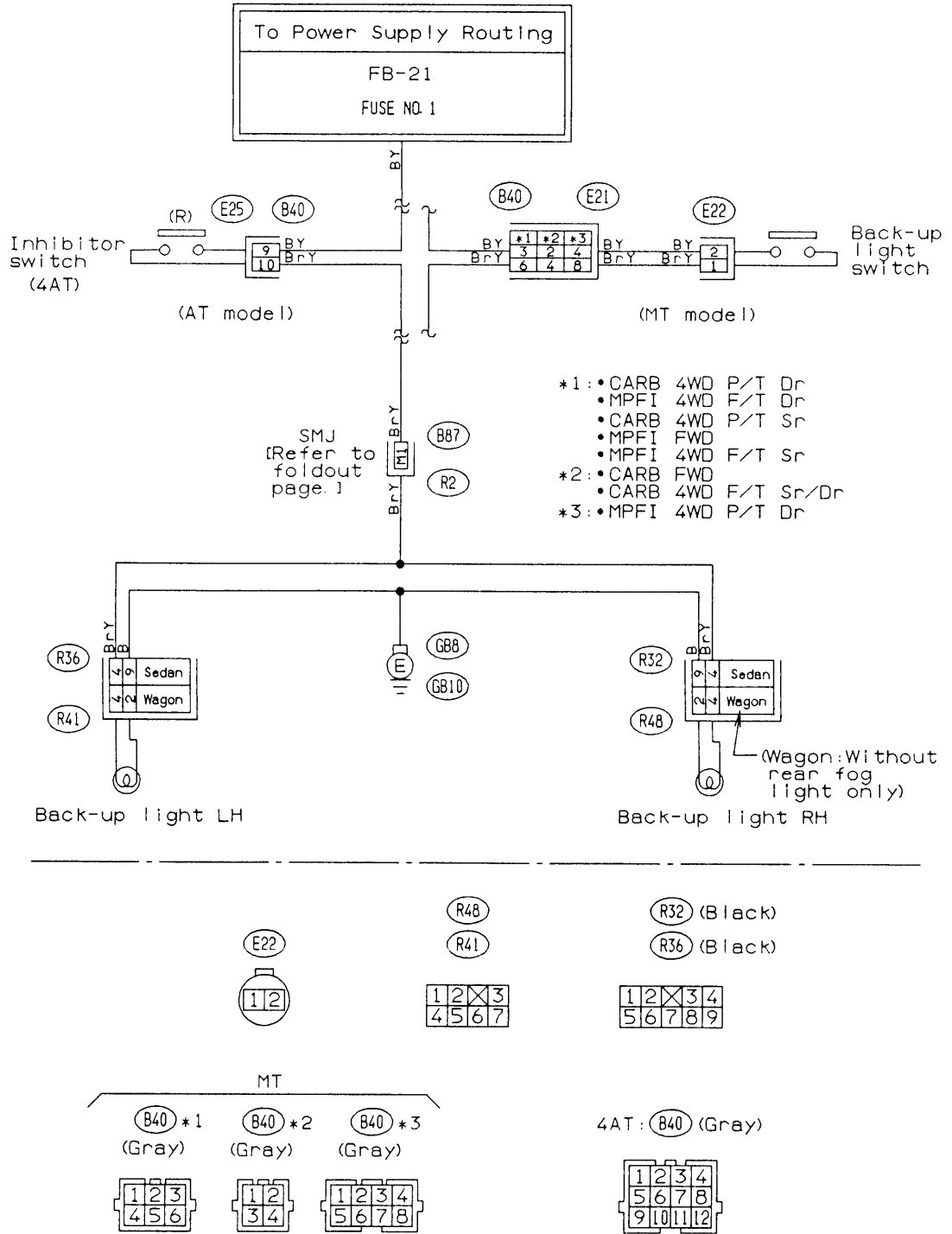


Fig. 40

BR28-02

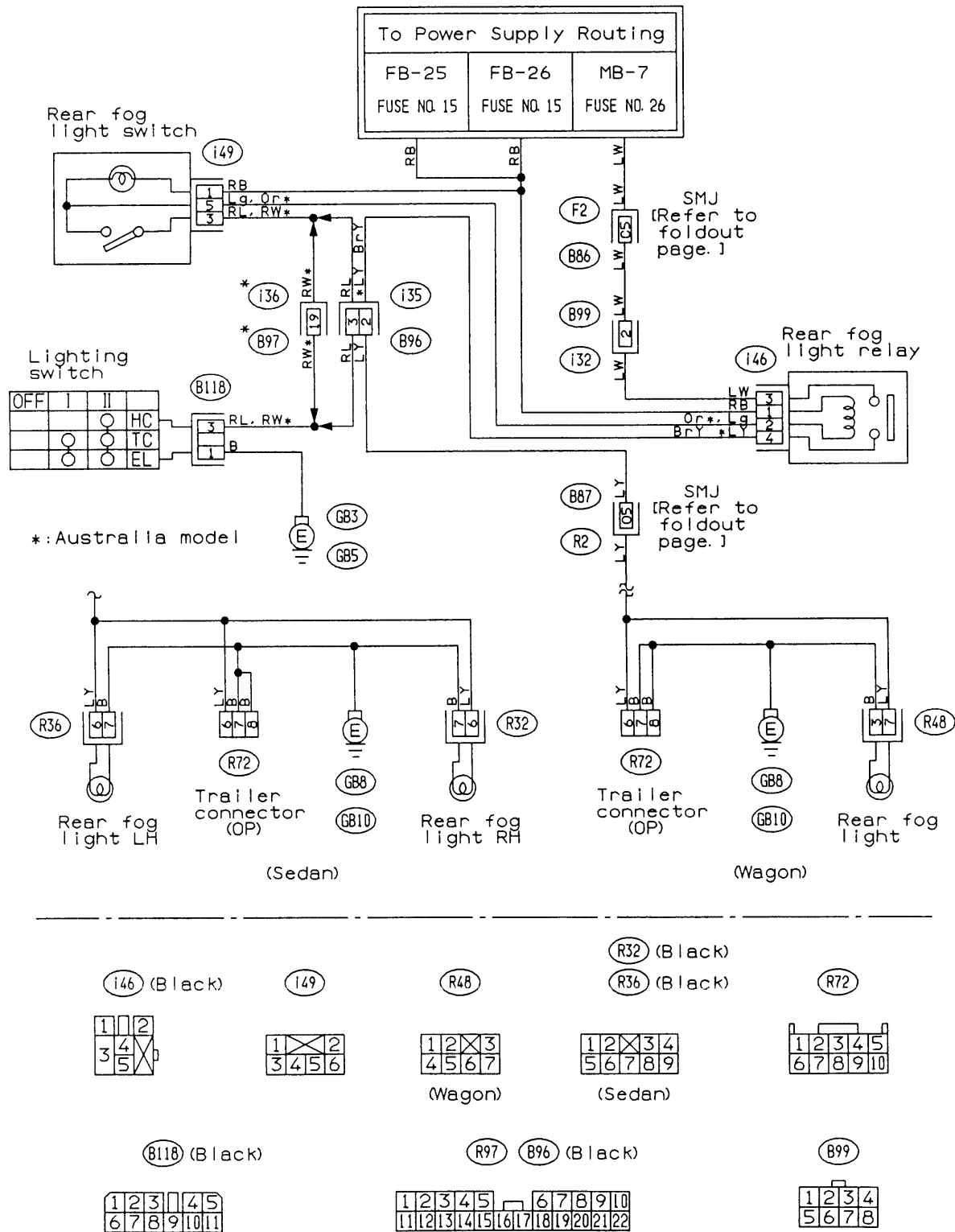
11. BACK-UP LIGHT



BR29-02

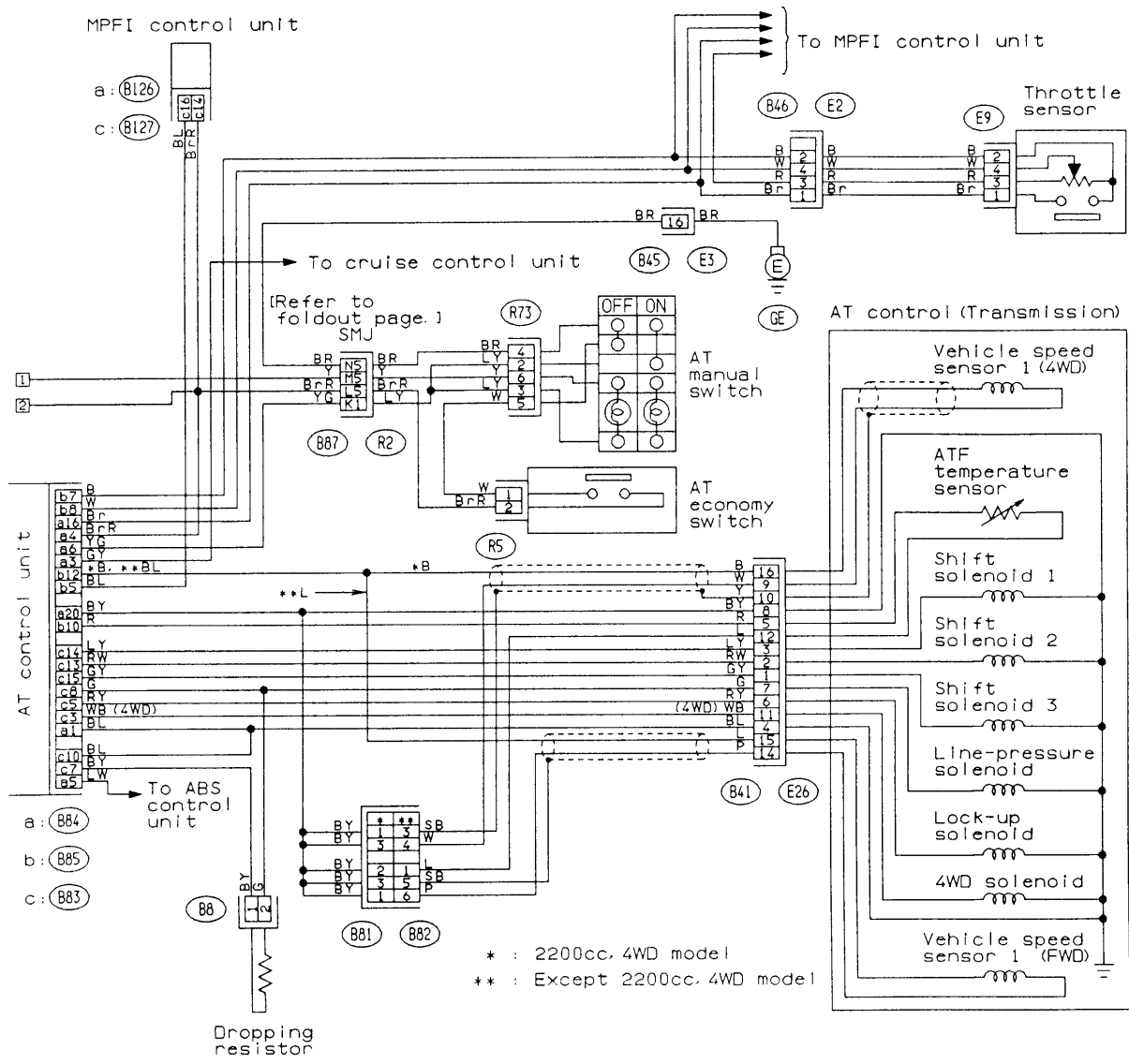
Fig. 41

12. REAR FOG LIGHT



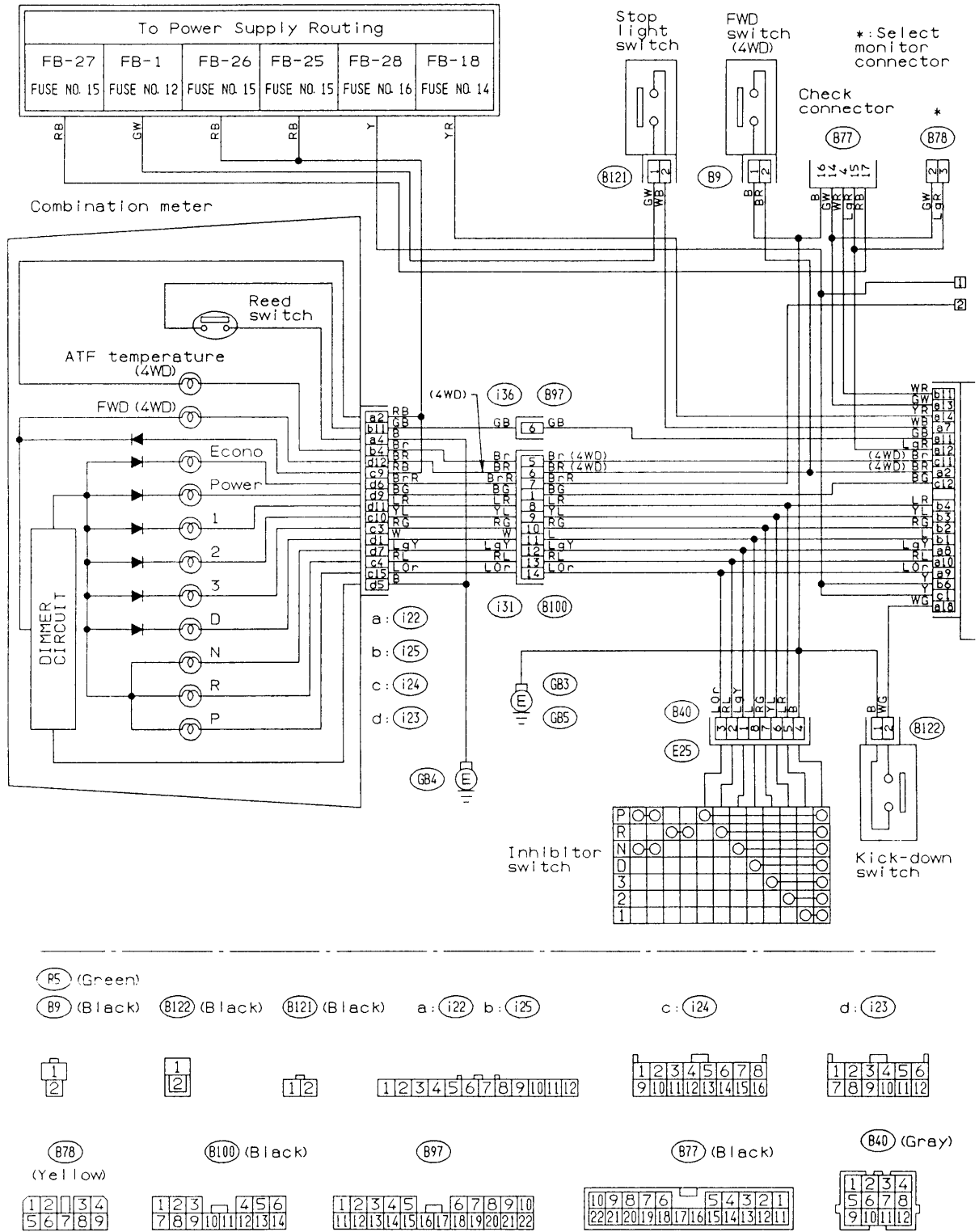
BR30-02

Fig. 42



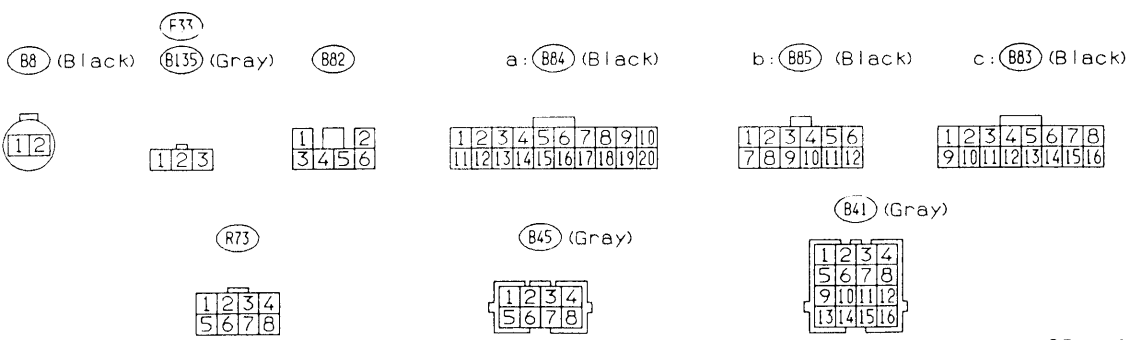
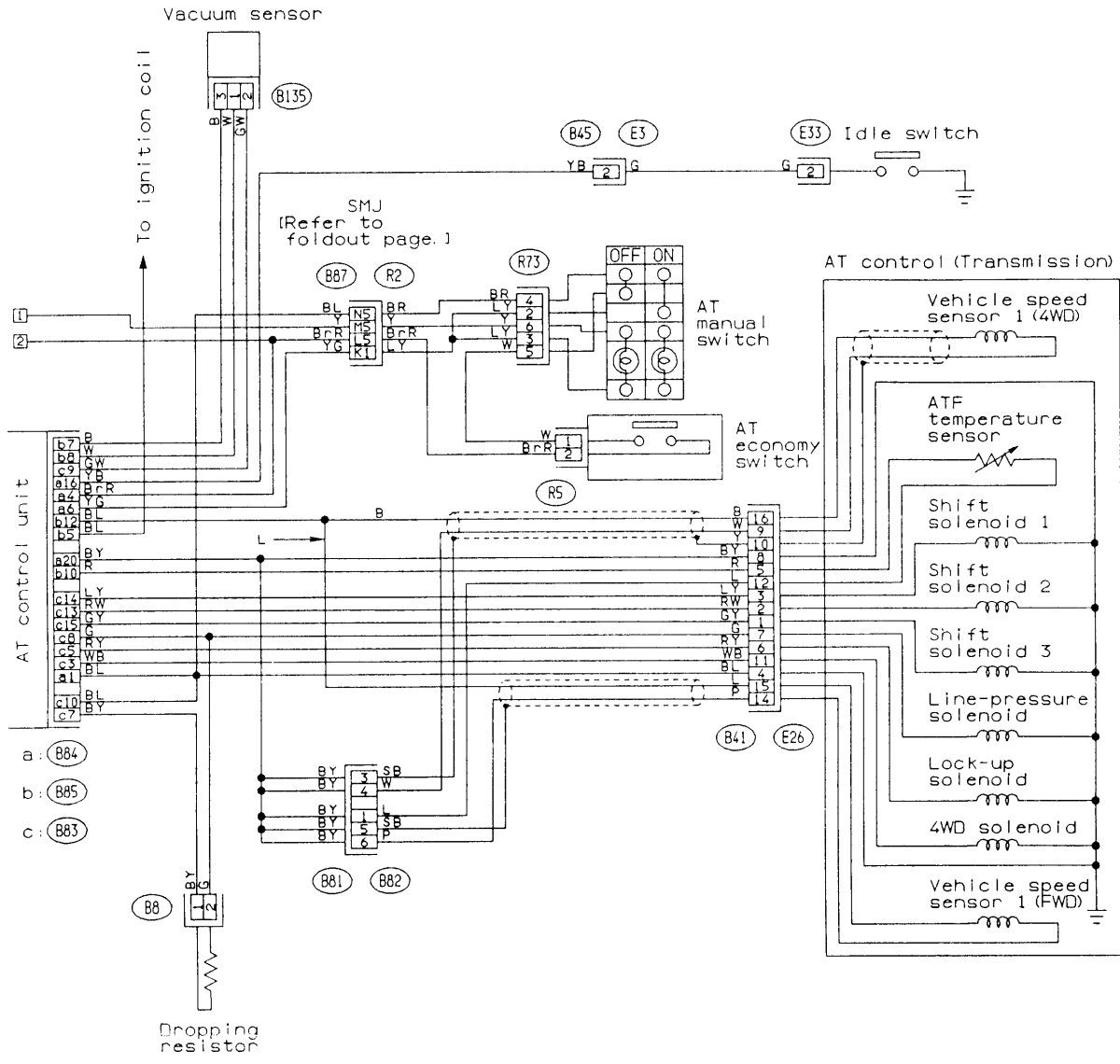
BR41-068

CARBURETOR MODEL



BR41-07A

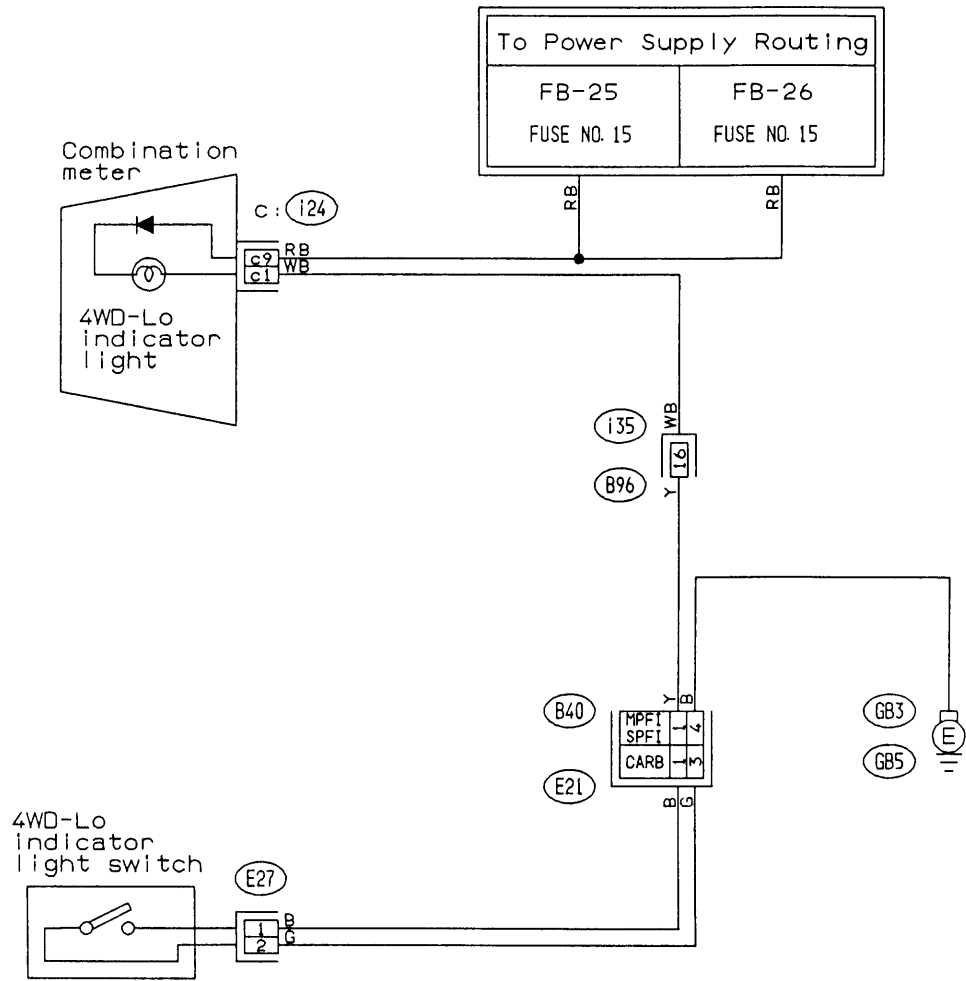
Fig. 43-2



BR41-07B

14. 4WD—MT

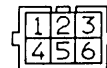
FULL-TIME DUAL RANGE



E27

B40 (Gray)

B40 (Gray)

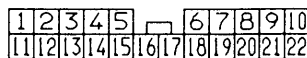
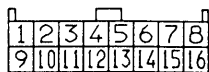


(Carburetor engine model)

(MPFI/SPFI engine model)

c: 124

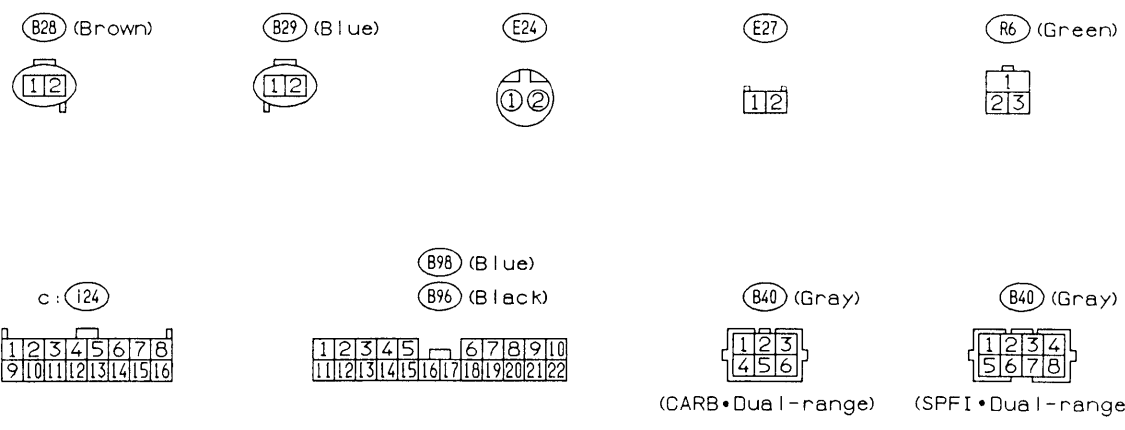
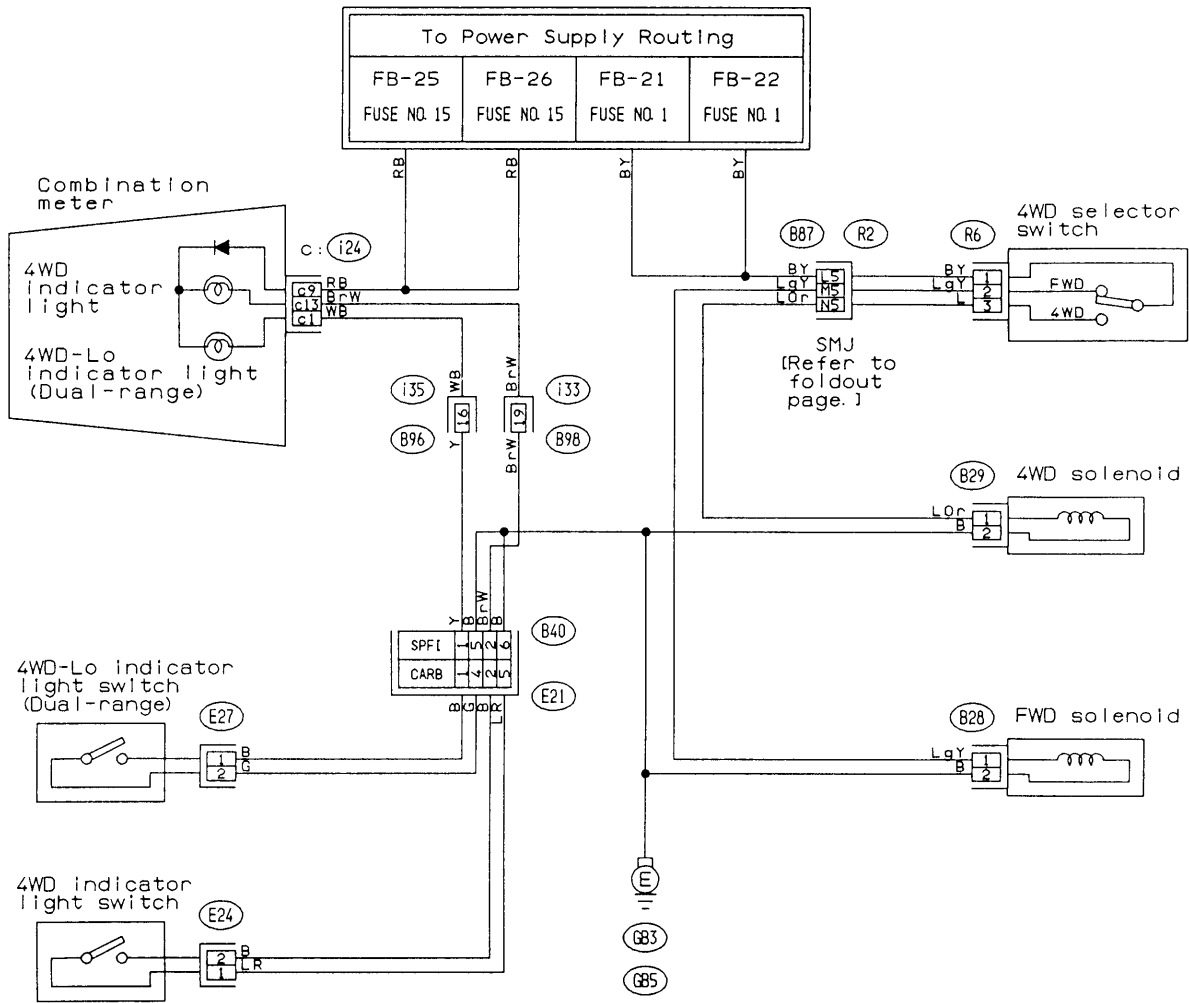
B96 (Black)



BR40-05

Fig. 44-1

PART-TIME DUAL RANGE



BR40-06

Fig. 44-2

15. FRONT WIPER AND WASHER

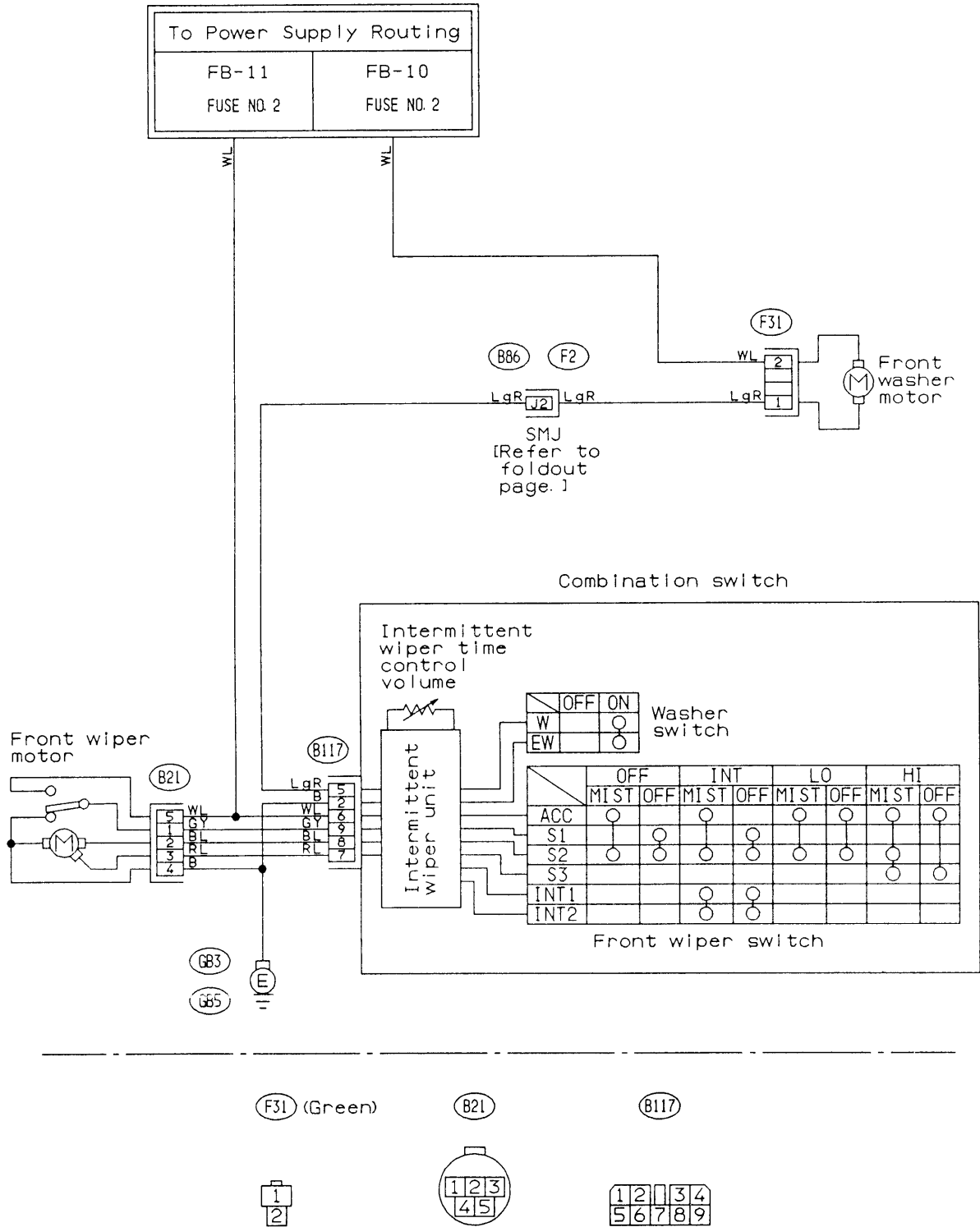
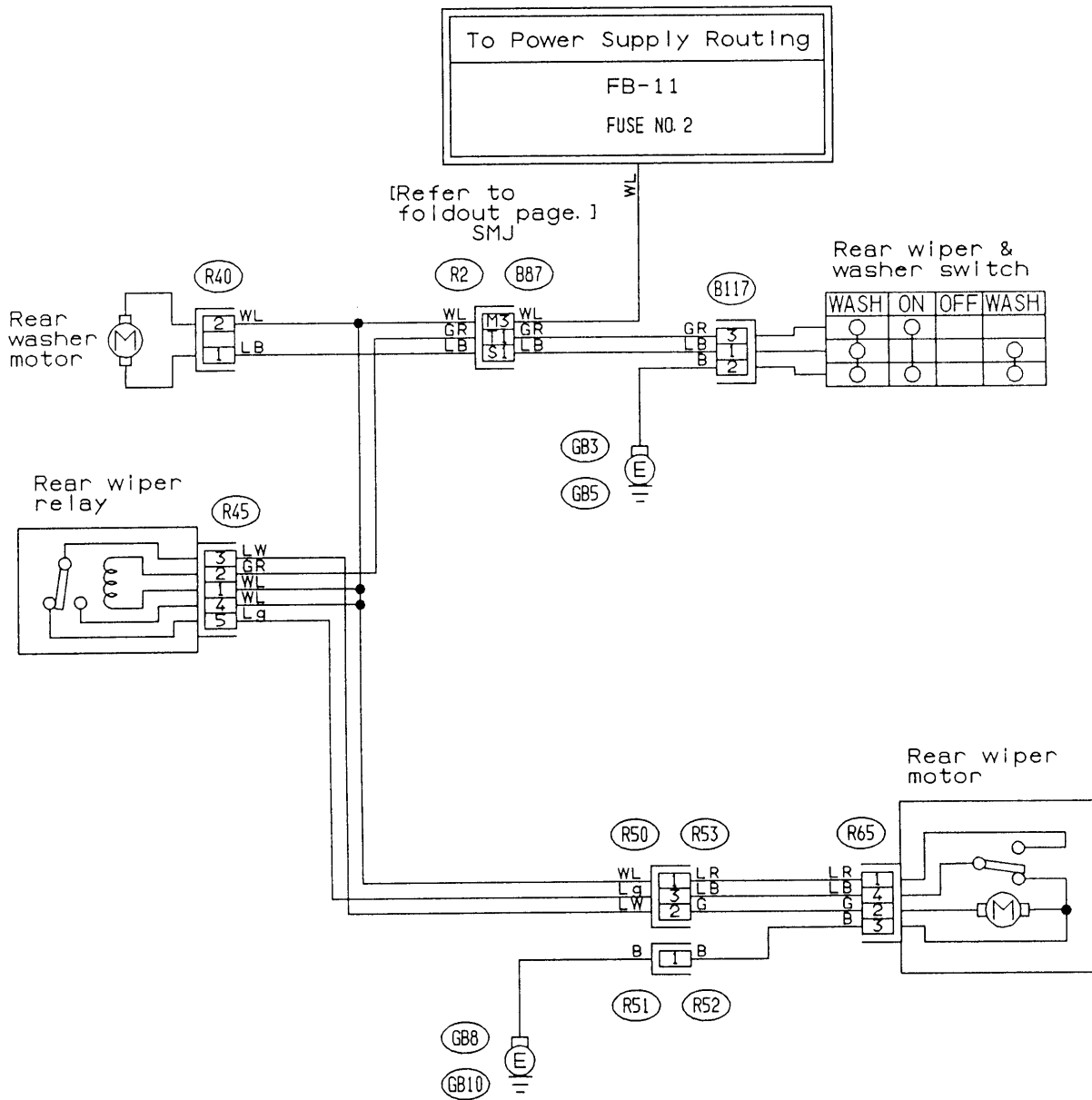


Fig. 45

BR50-02

16. REAR WIPER AND WASHER



(R40) (Green)

(R52)

(R65)

(R45)

(R53)

(B117)
(Black)

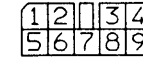


Fig. 46

BR51-02

17. HEADLIGHT WASHER

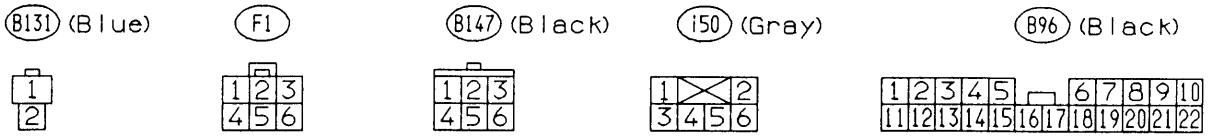
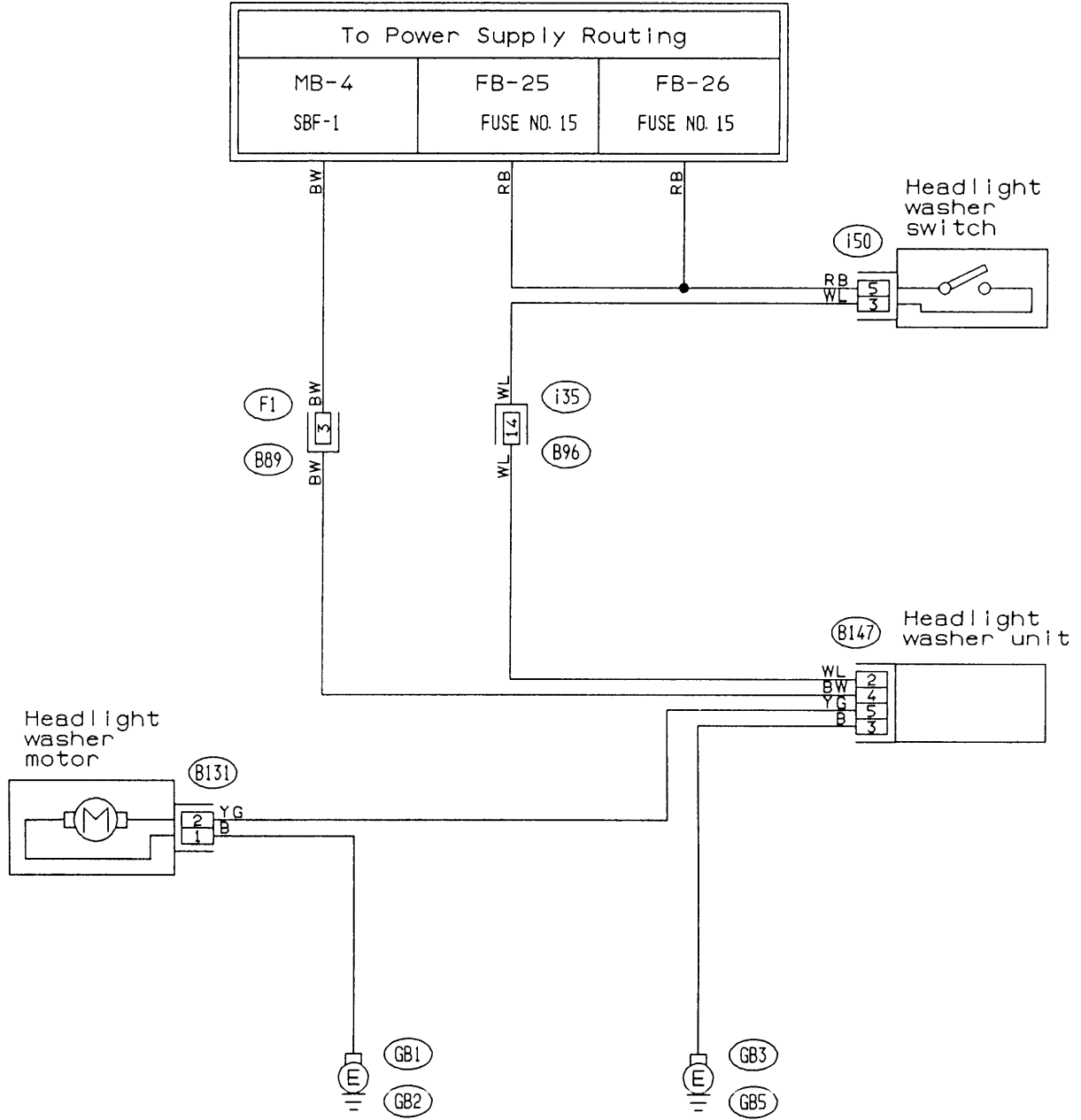


Fig. 47

BR53-02

18. REAR WINDOW DEFOGGER

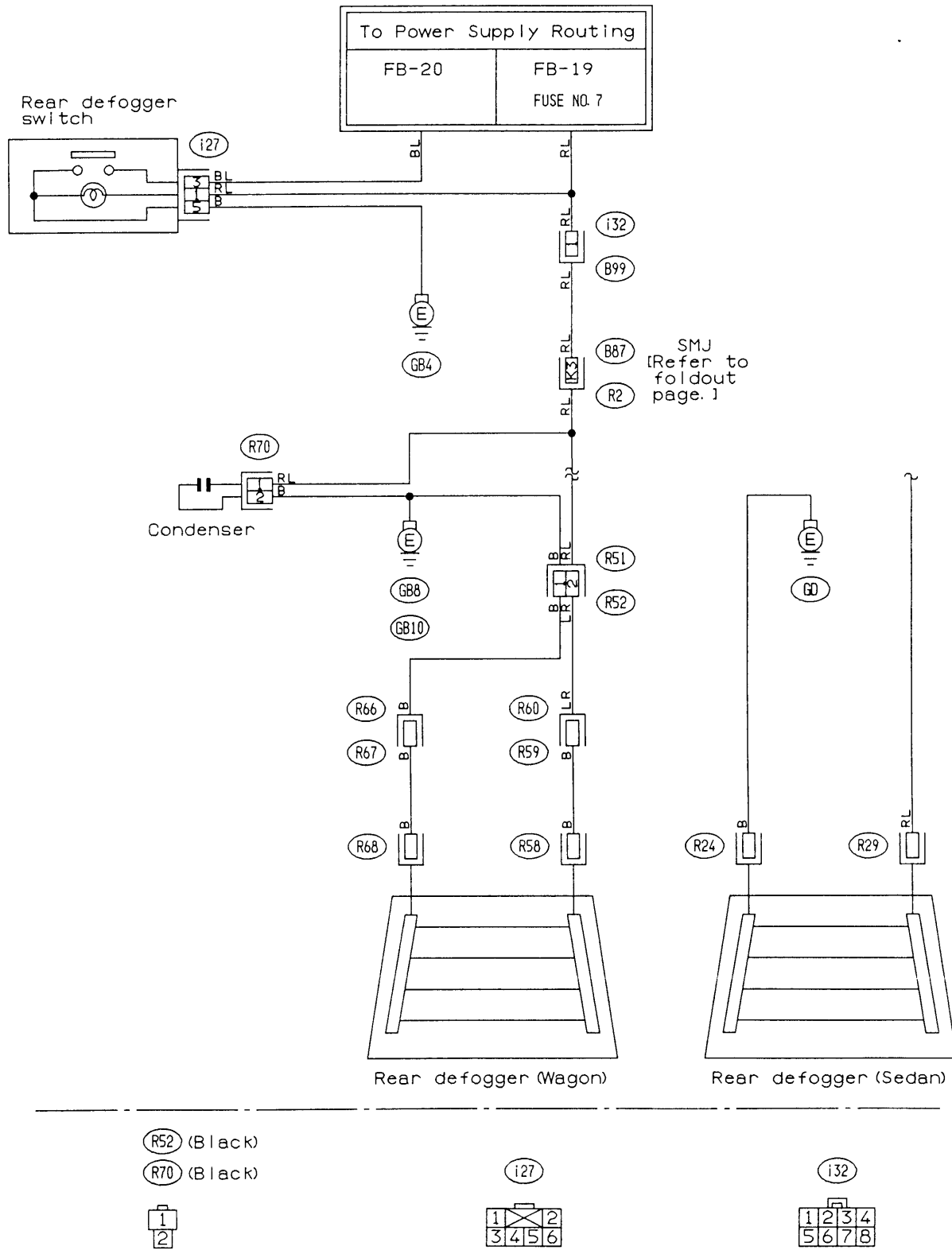
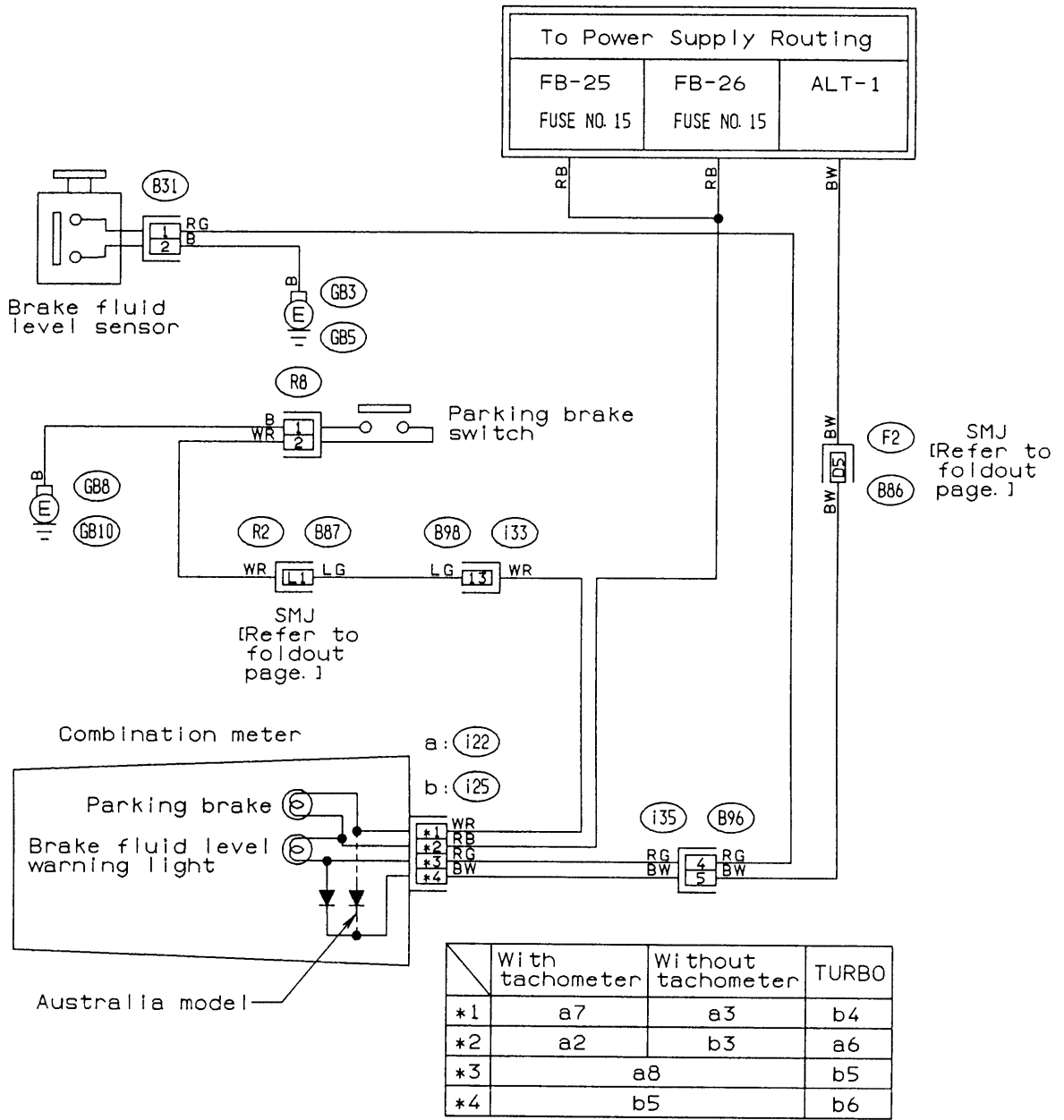


Fig. 48

BR52-03

19. PARKING BRAKE AND BRAKE FLUID LEVEL WARNING



BR60-02

Fig. 49

20. FUEL GAUGE

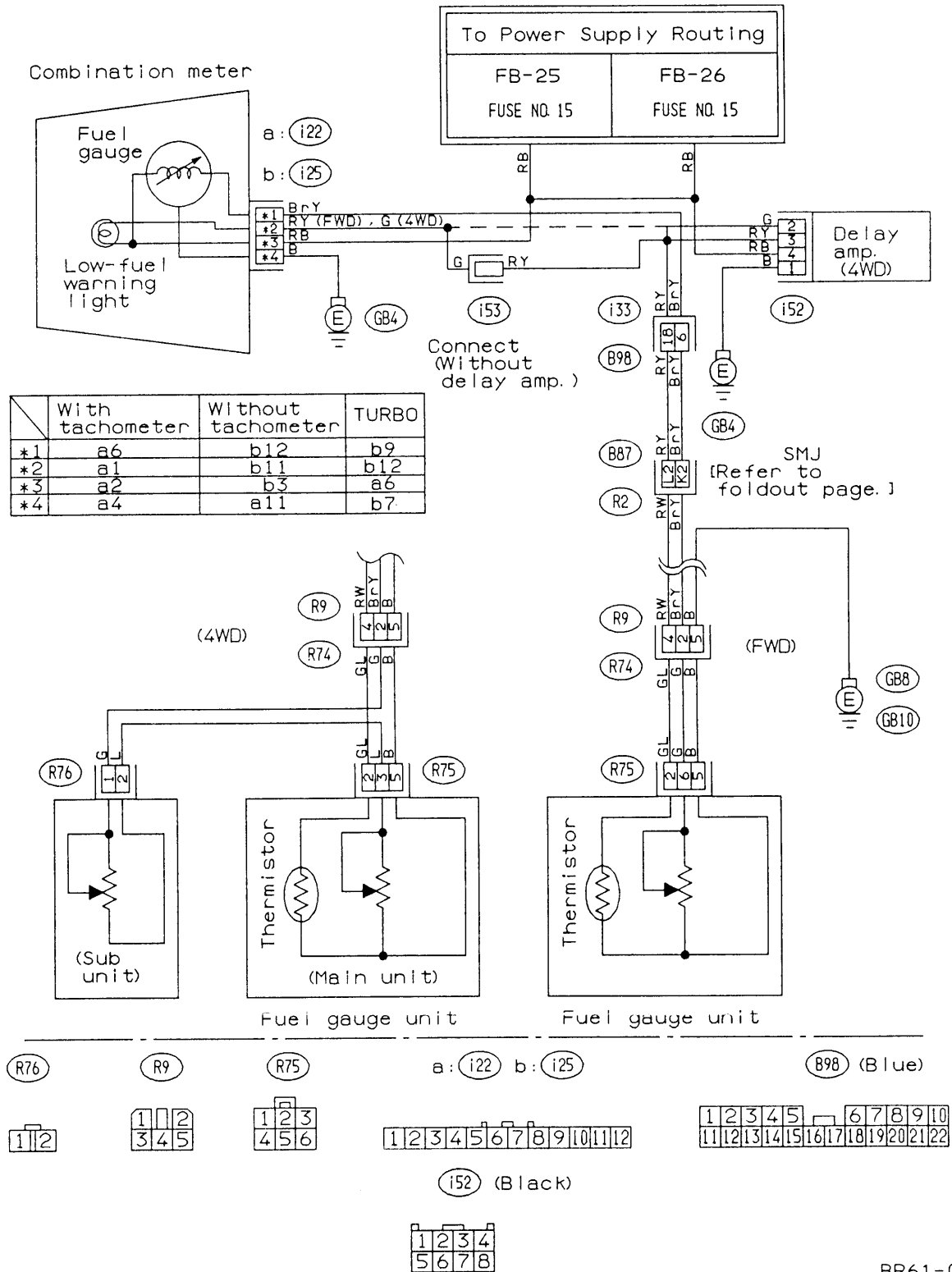
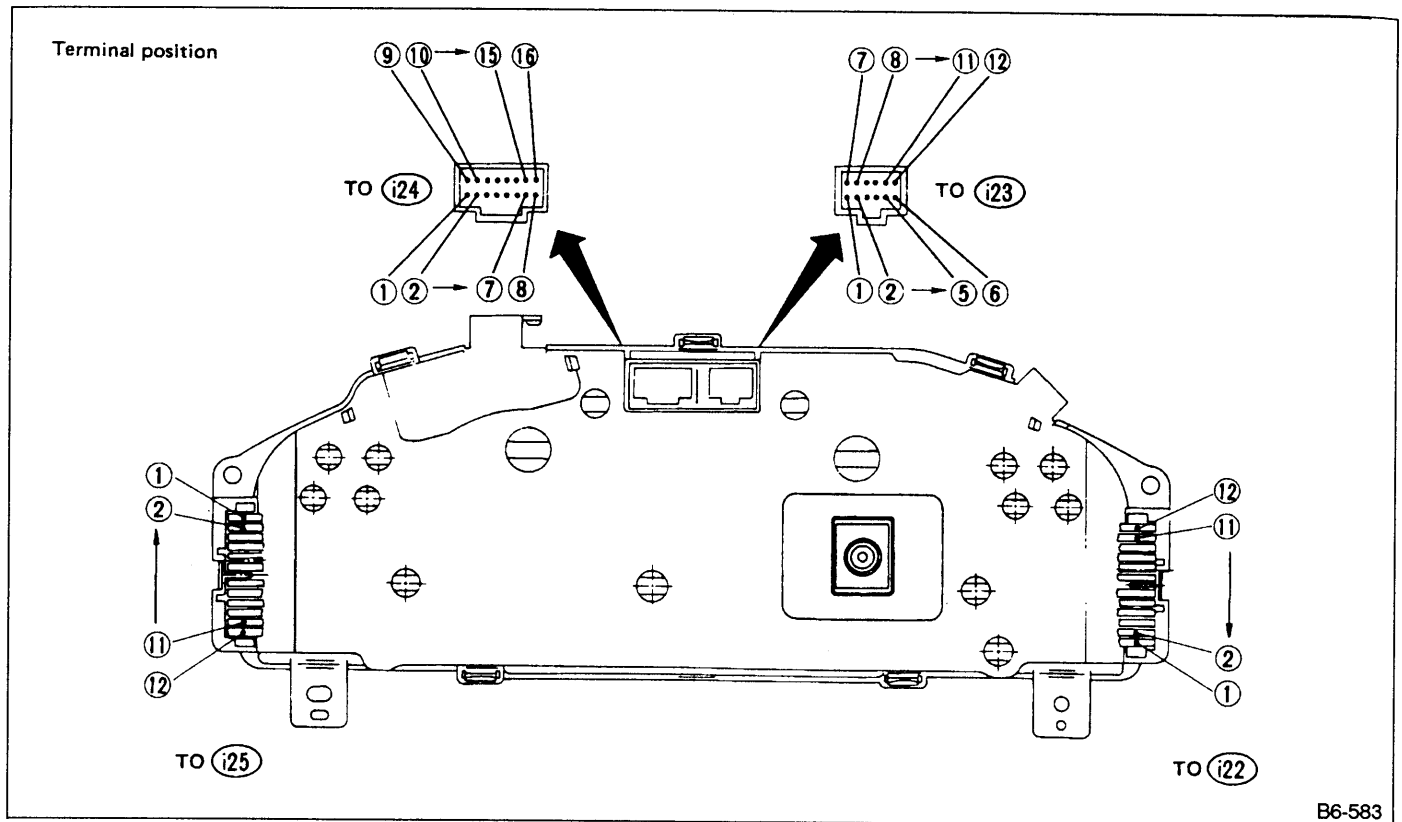


Fig. 50

BR61-03

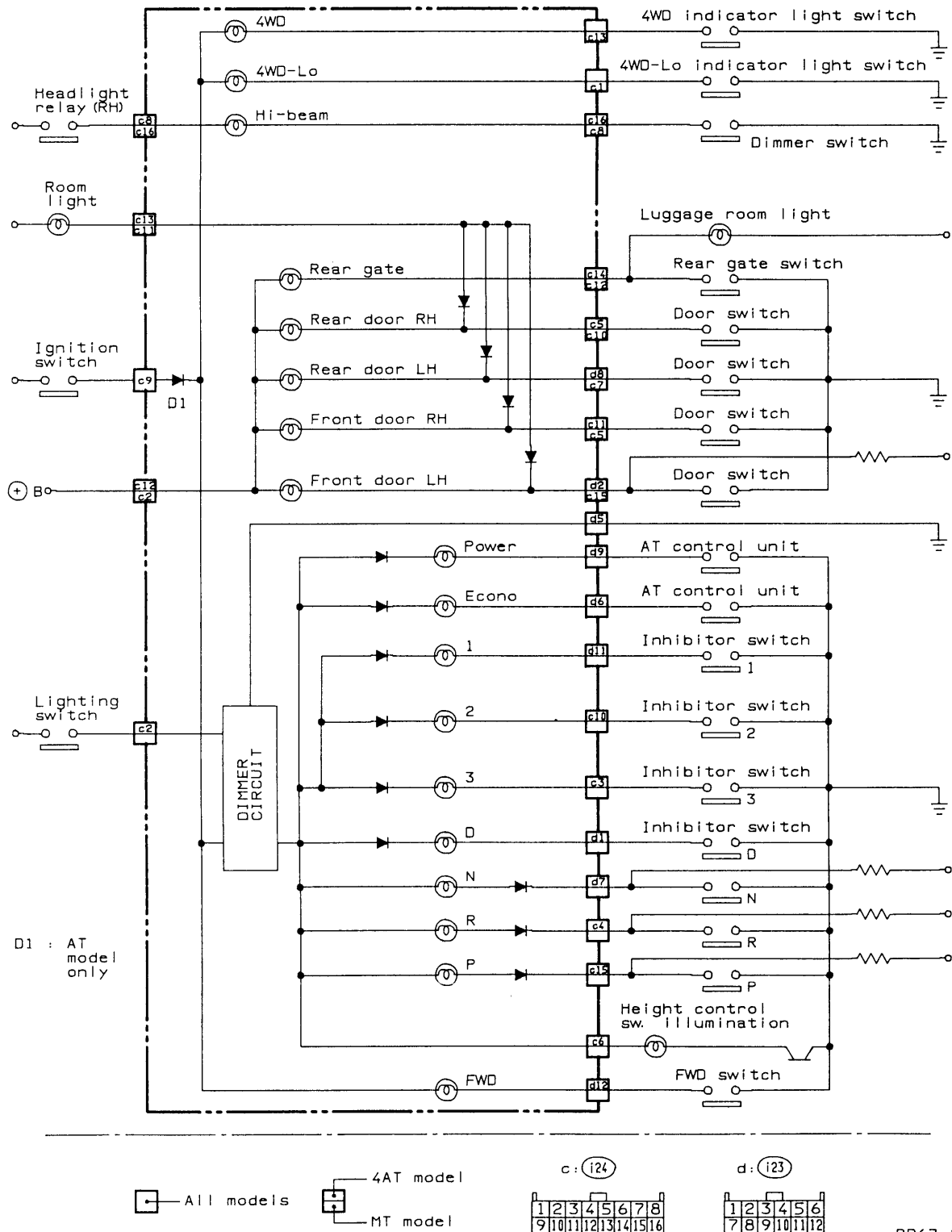
21. COMBINATION METER



B6-583

Fig. 51

GRAPHIC MONITOR

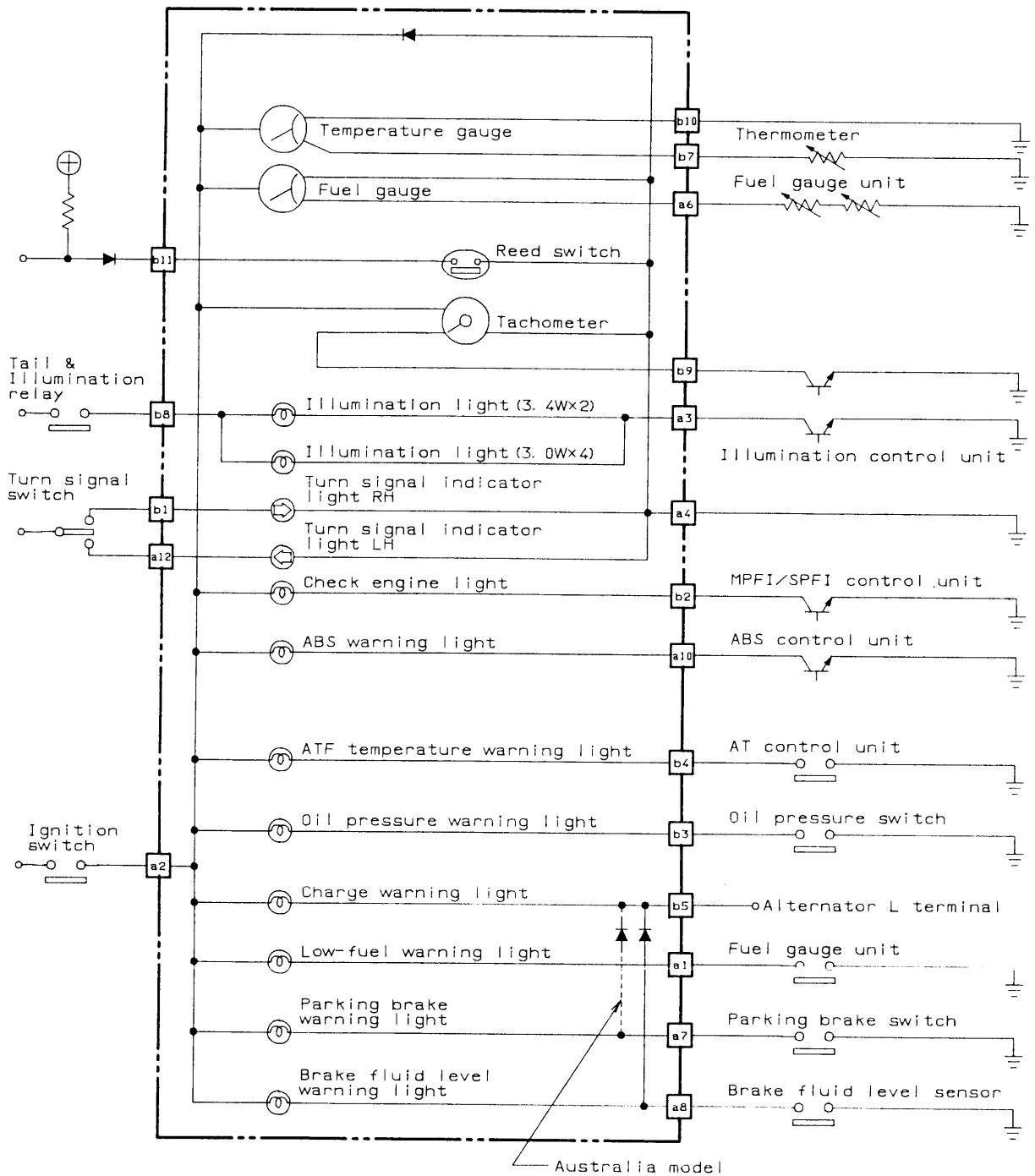


BR67-03

Fig. 52

WARNING AND ILLUMINATION

1. With tachometer (NA) model



a: (i22) b: (i25)

1 2 3 4 5 6 7 8 9 10 11 12

BR65-03

Fig. 53-1

2. Without tachometer model

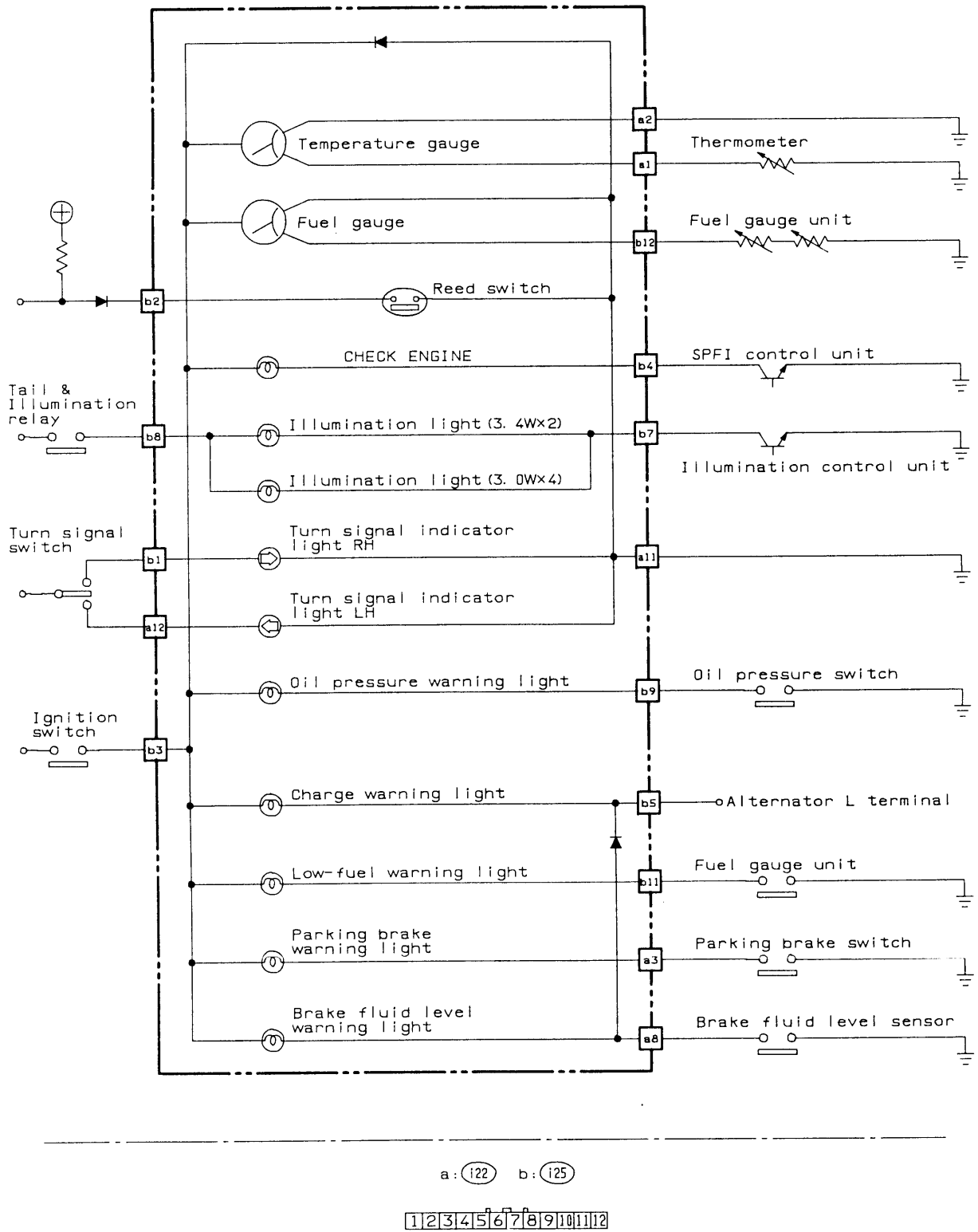
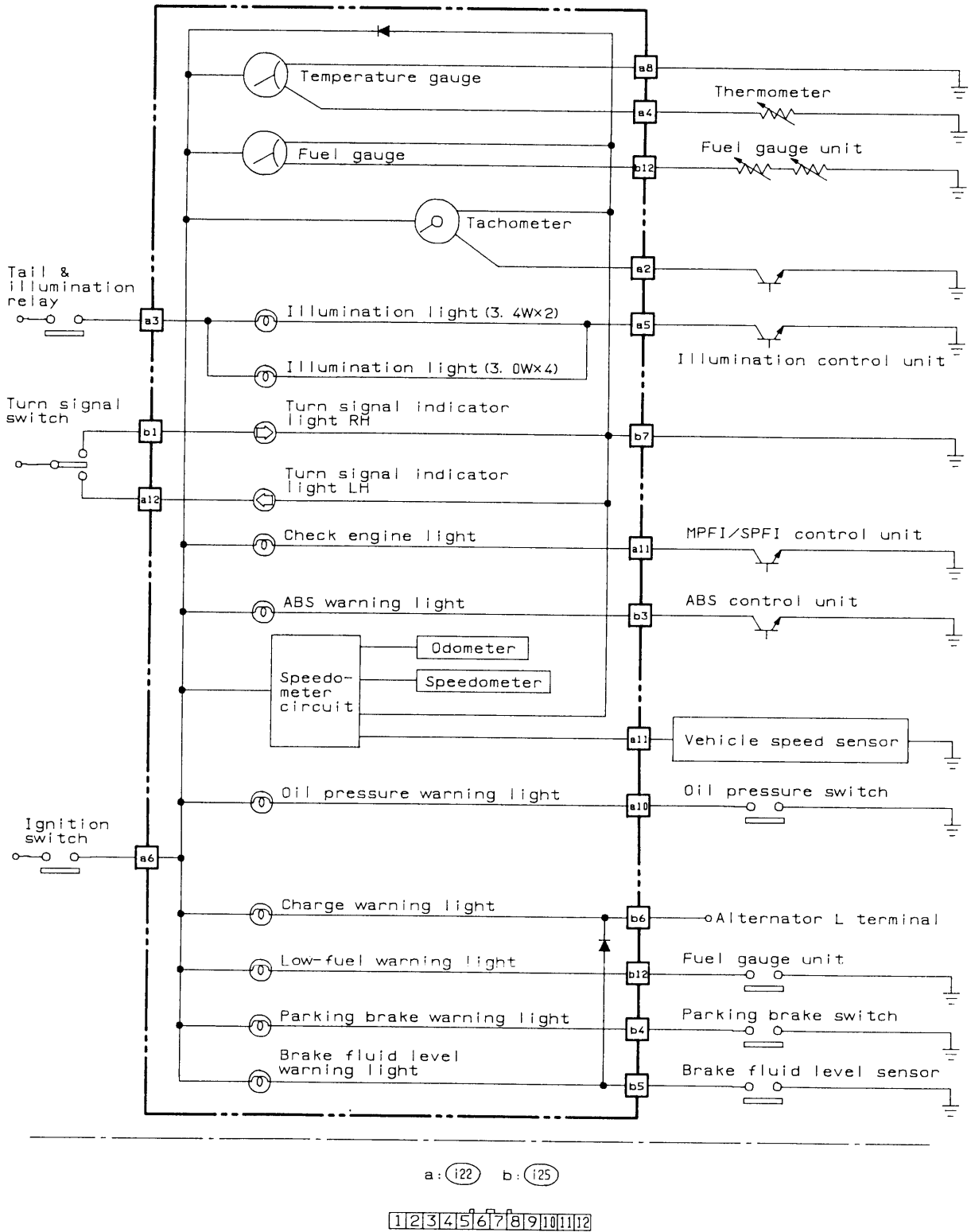


Fig. 53-2

3. With tachometer (TURBO) model

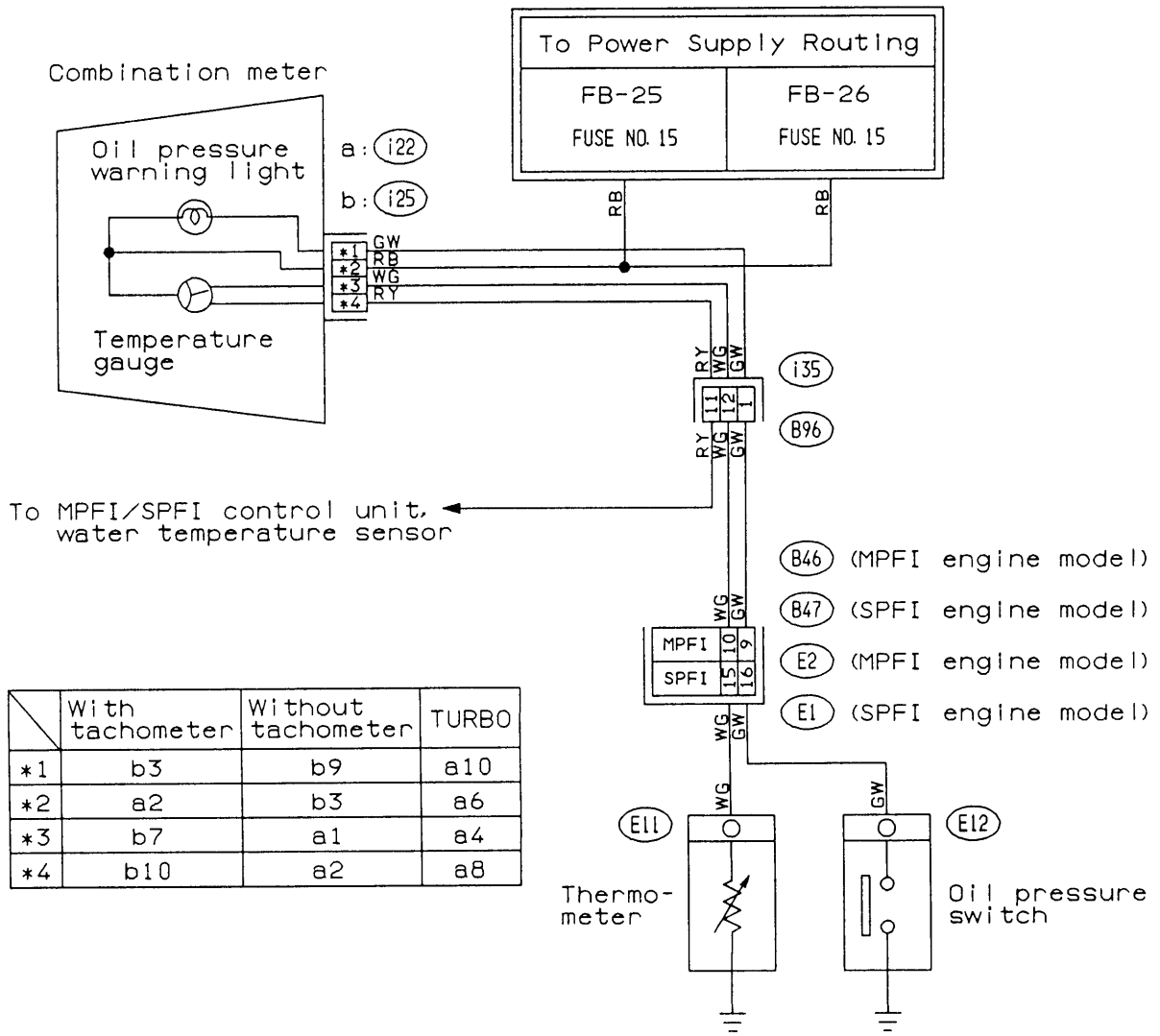


BR65-04

Fig. 53-3

22. OIL PRESSURE AND TEMPERATURE GAUGE

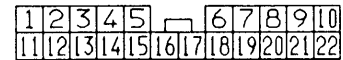
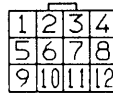
MPFI/SPFI MODEL (Refer to "Engine Electrical" for carburetor models.)



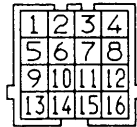
a: (i22) b: (i25)

(B46) (Gray)

(B96) (Black)



(B47) (Gray)



BR66-03

Fig. 54

23. POWER WINDOW

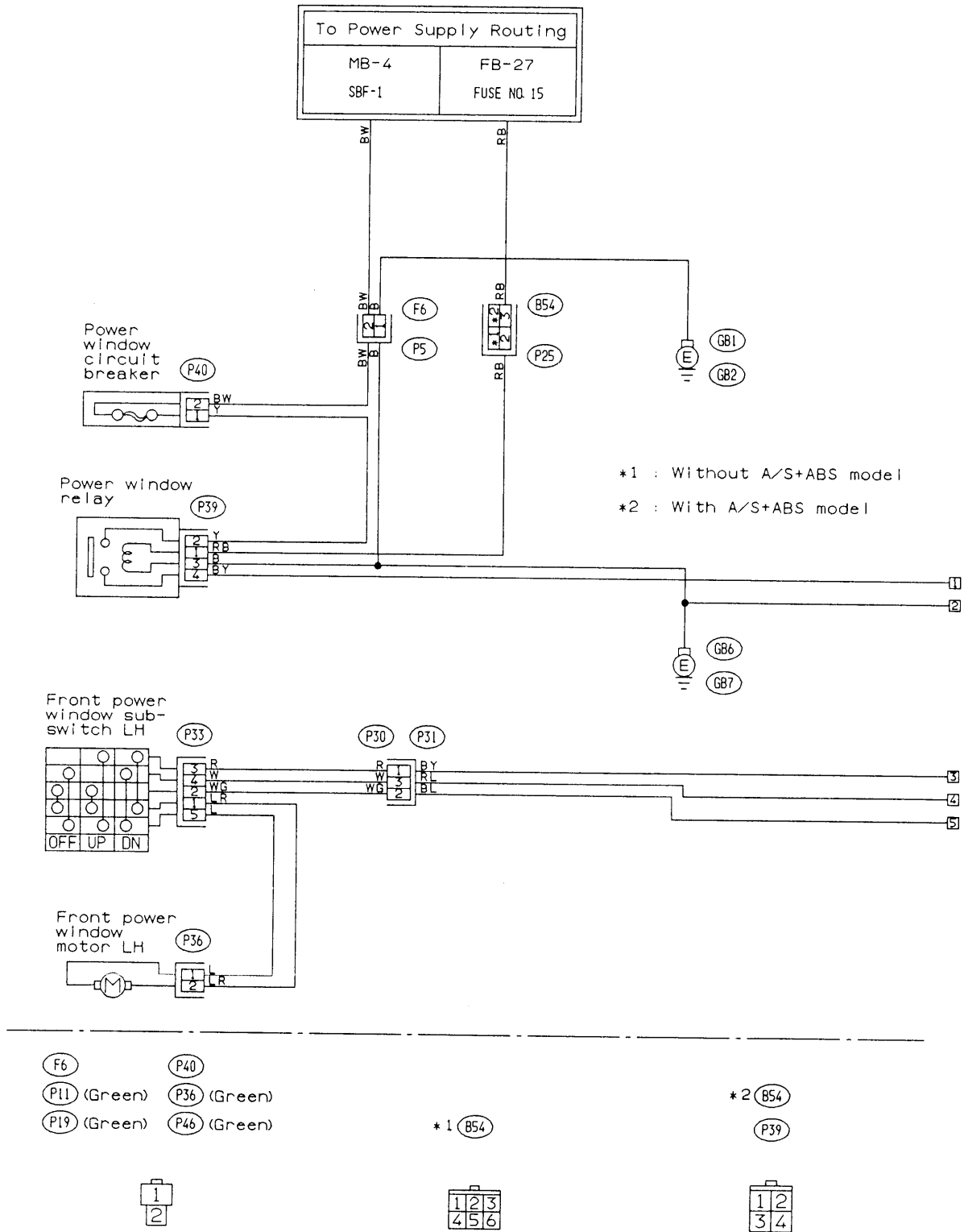
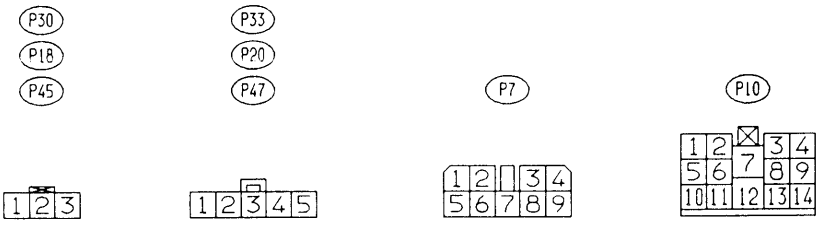
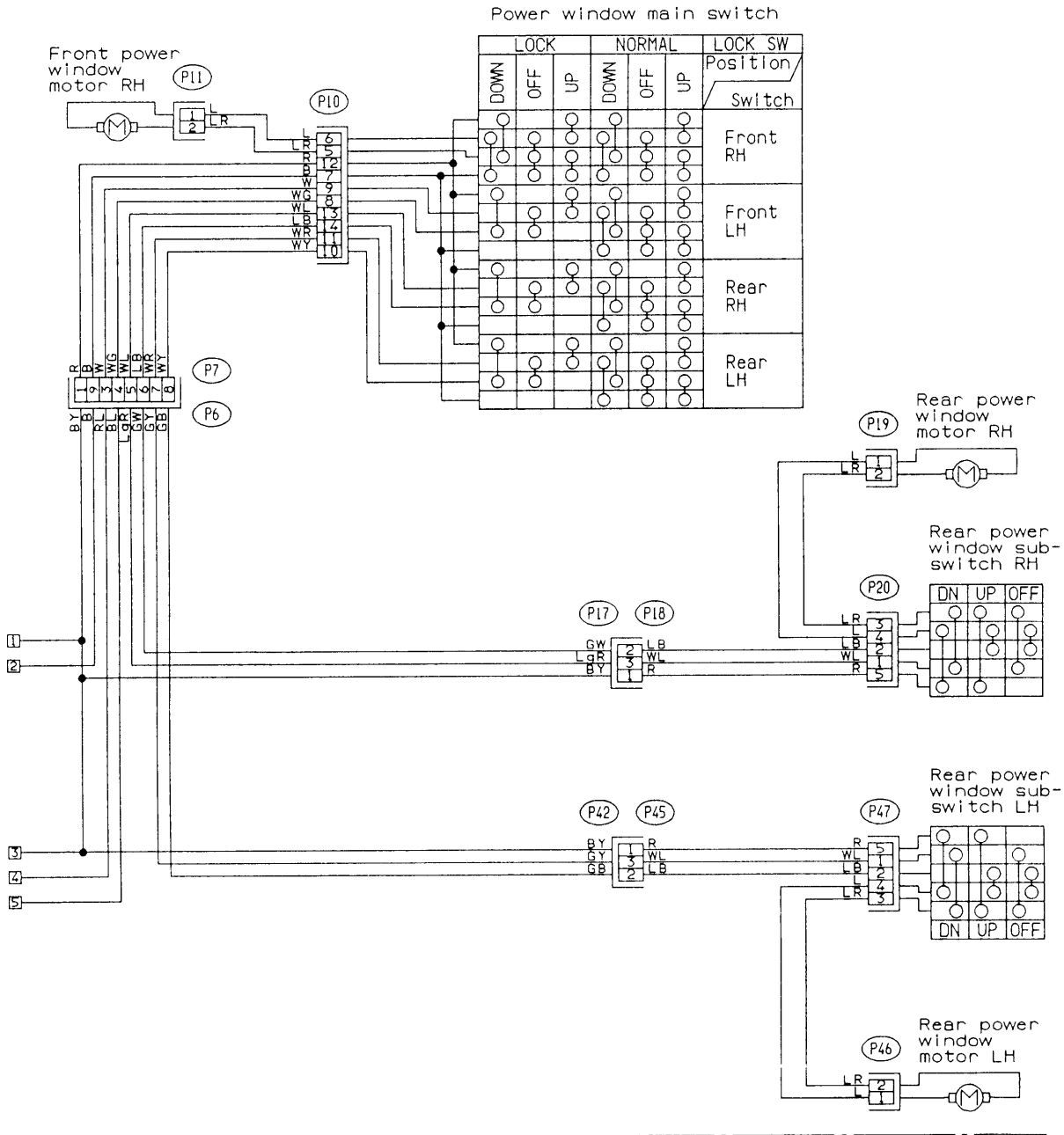


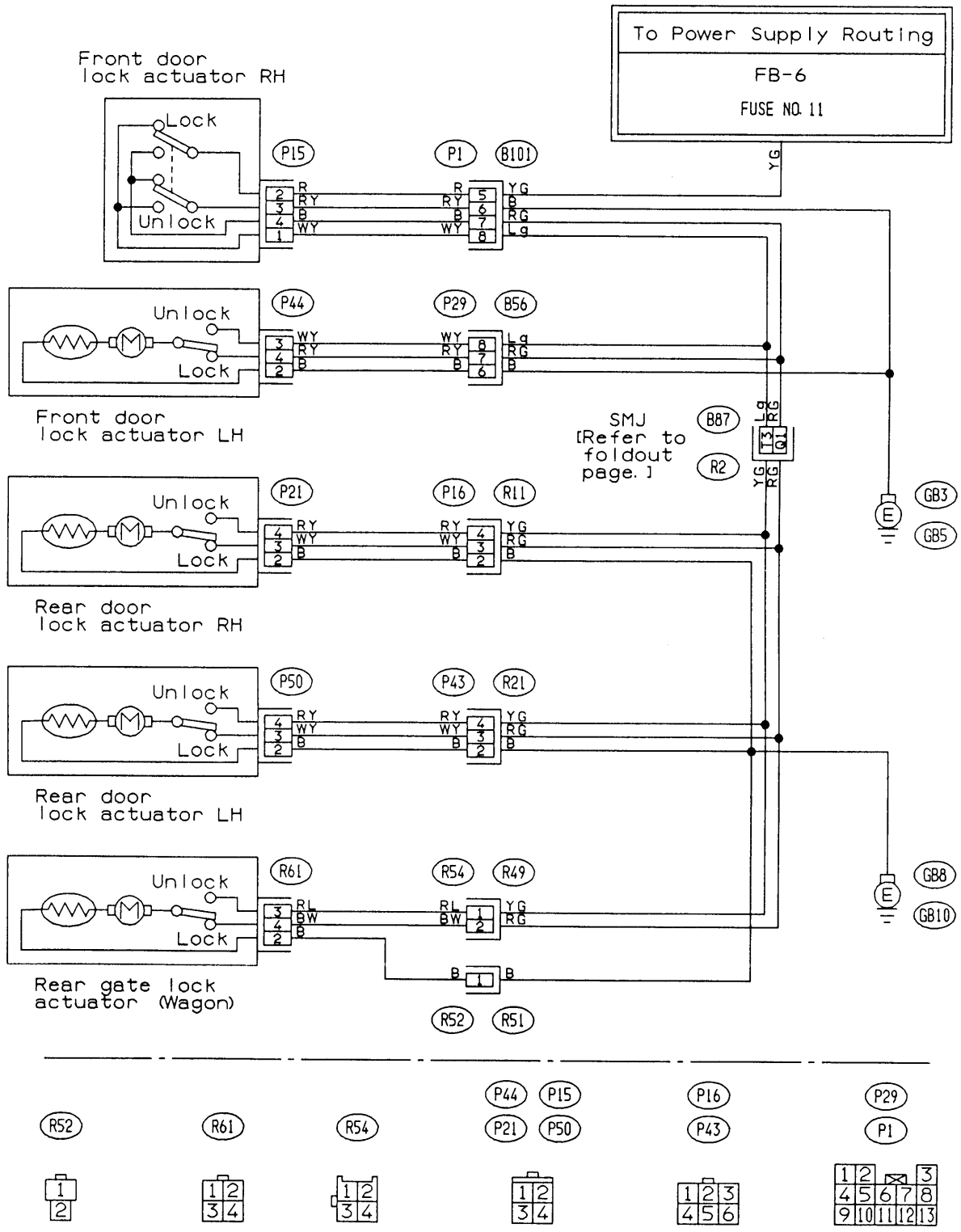
Fig. 55

BR70-02A



BR70-02B

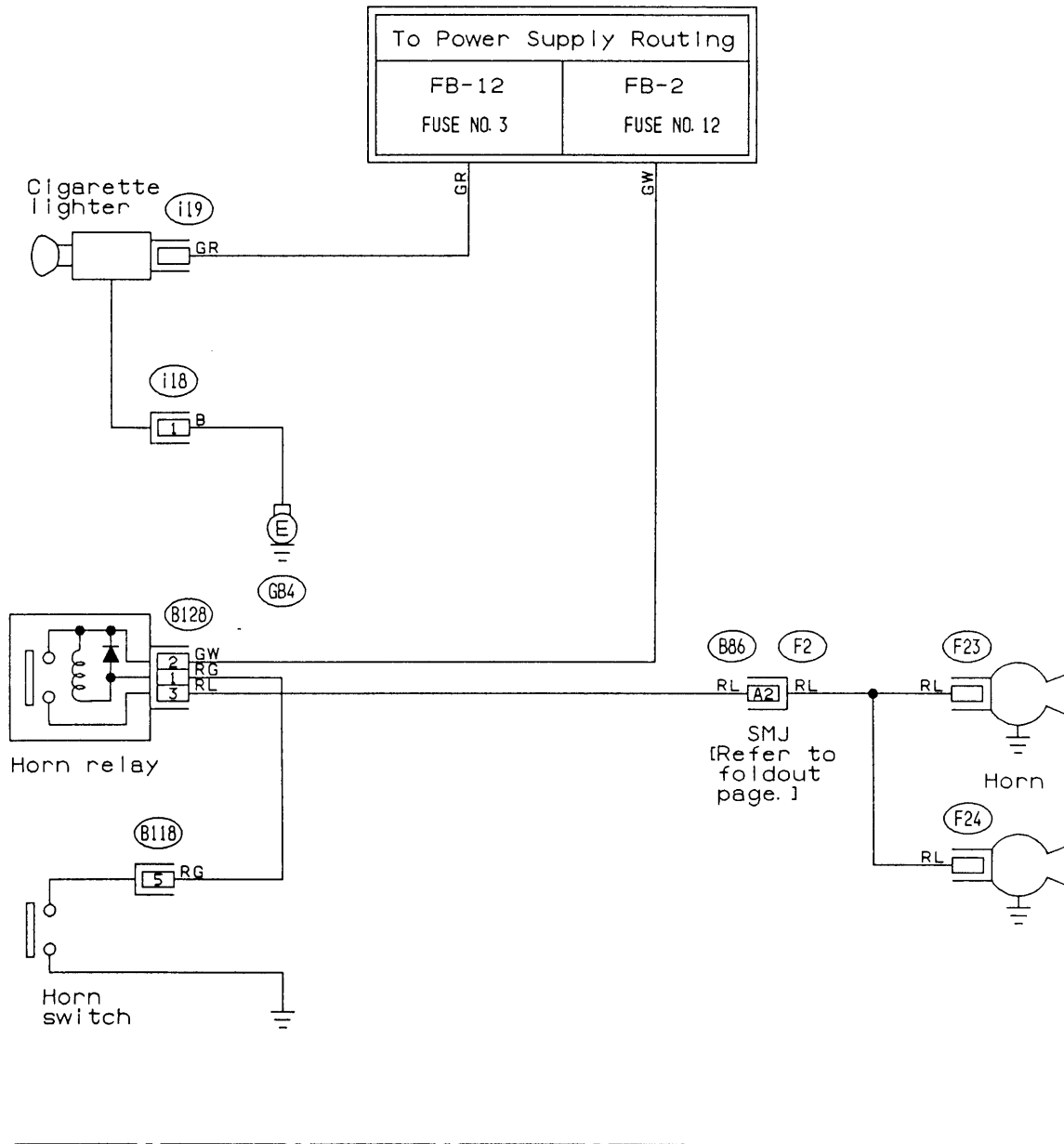
24. DOOR LOCK



BR73-02

Fig. 56

25. HORN AND CIGARETTE LIGHTER



(i18)
(B128) (Black)

(B118) (Black)

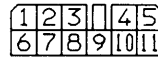


Fig. 57

BR74-03

26. SUNROOF • SPOT LIGHT AND VANITY MIRROR

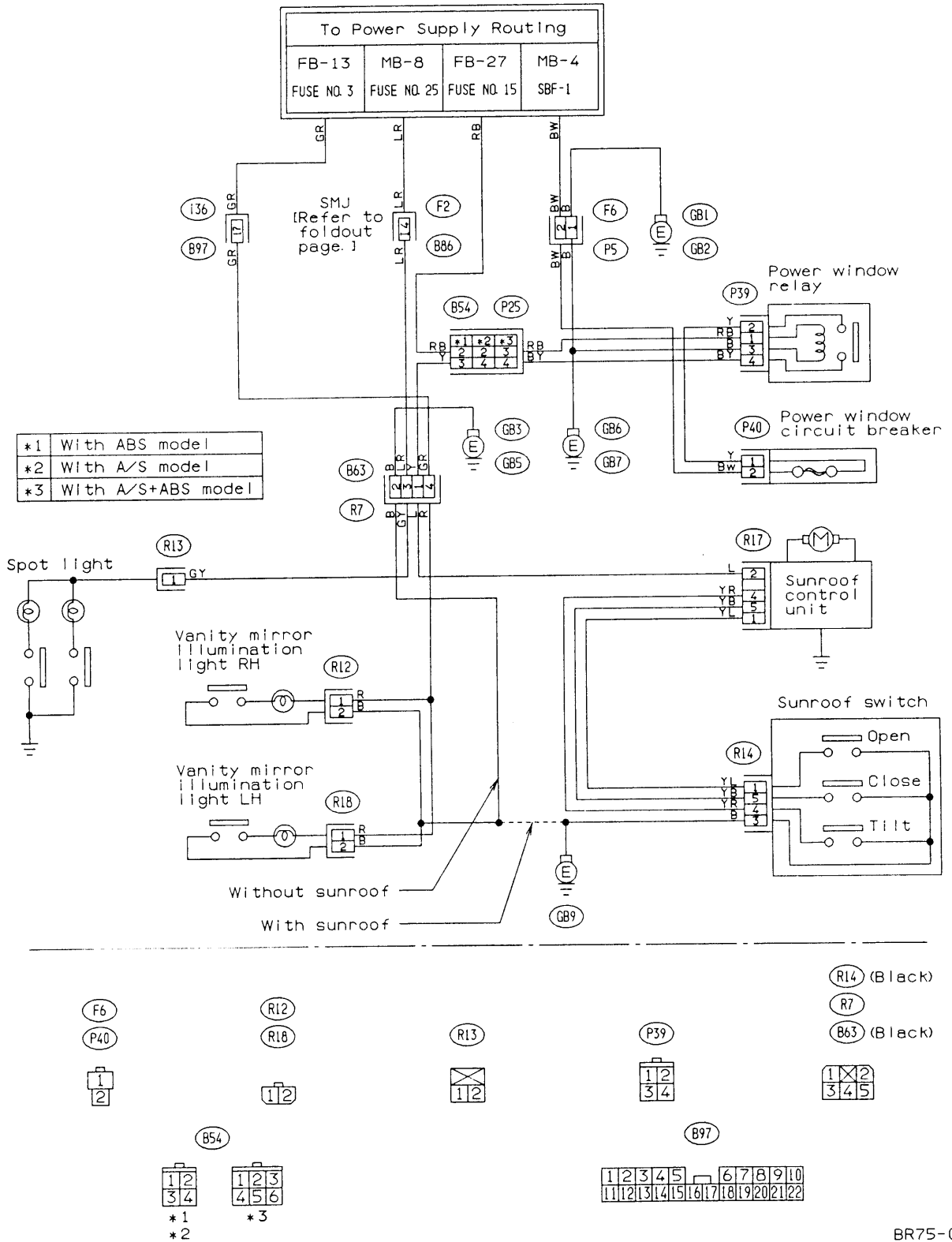
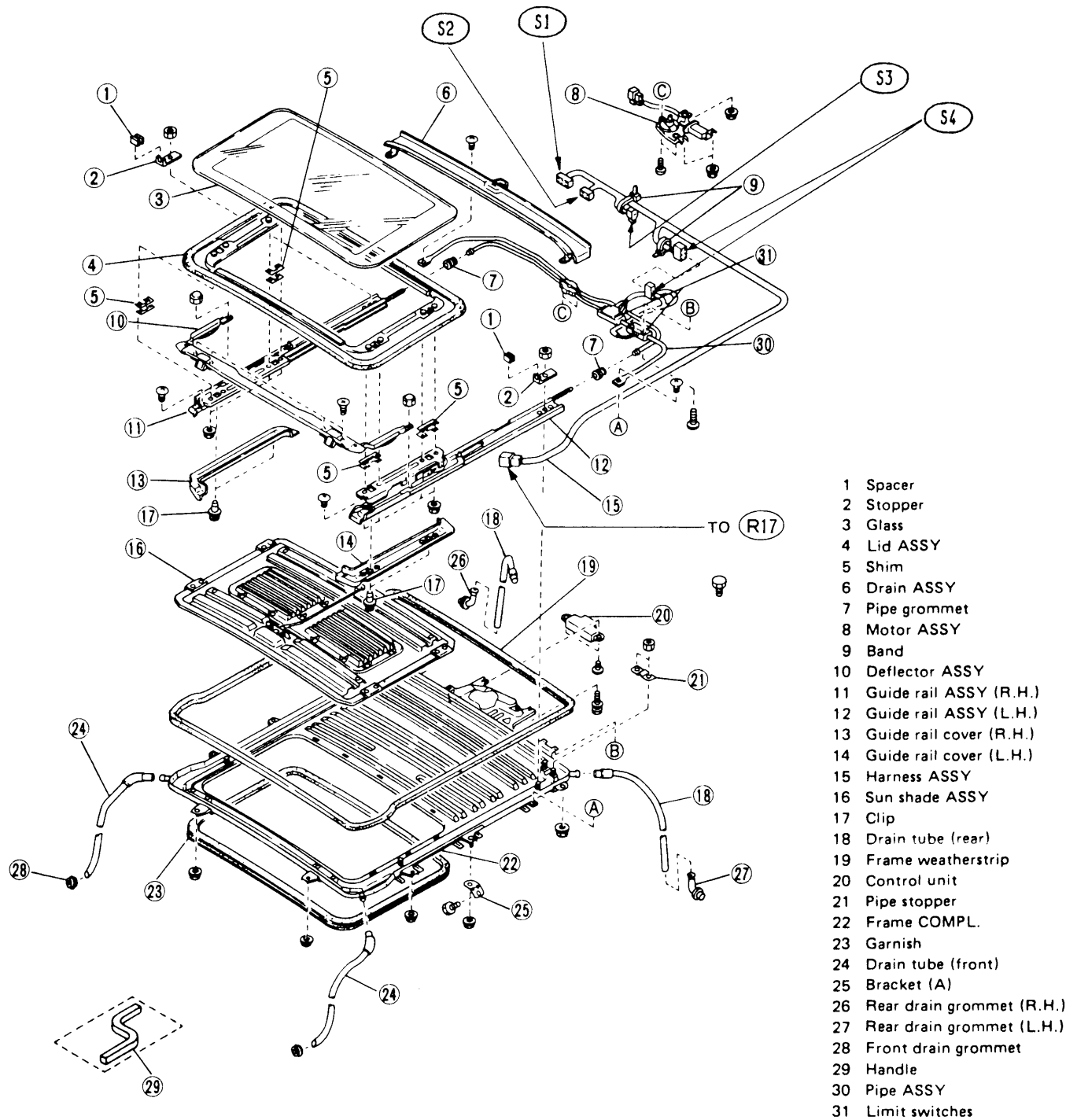


Fig. 58-1

Detail of Sunroof Control Unit



- 1 Spacer
- 2 Stopper
- 3 Glass
- 4 Lid ASSY
- 5 Shim
- 6 Drain ASSY
- 7 Pipe grommet
- 8 Motor ASSY
- 9 Band
- 10 Deflector ASSY
- 11 Guide rail ASSY (R.H.)
- 12 Guide rail ASSY (L.H.)
- 13 Guide rail cover (R.H.)
- 14 Guide rail cover (L.H.)
- 15 Harness ASSY
- 16 Sun shade ASSY
- 17 Clip
- 18 Drain tube (rear)
- 19 Frame weatherstrip
- 20 Control unit
- 21 Pipe stopper
- 22 Frame COMPL.
- 23 Garnish
- 24 Drain tube (front)
- 25 Bracket (A)
- 26 Rear drain grommet (R.H.)
- 27 Rear drain grommet (L.H.)
- 28 Front drain grommet
- 29 Handle
- 30 Pipe ASSY
- 31 Limit switches

Fig. 58-2

B6-512

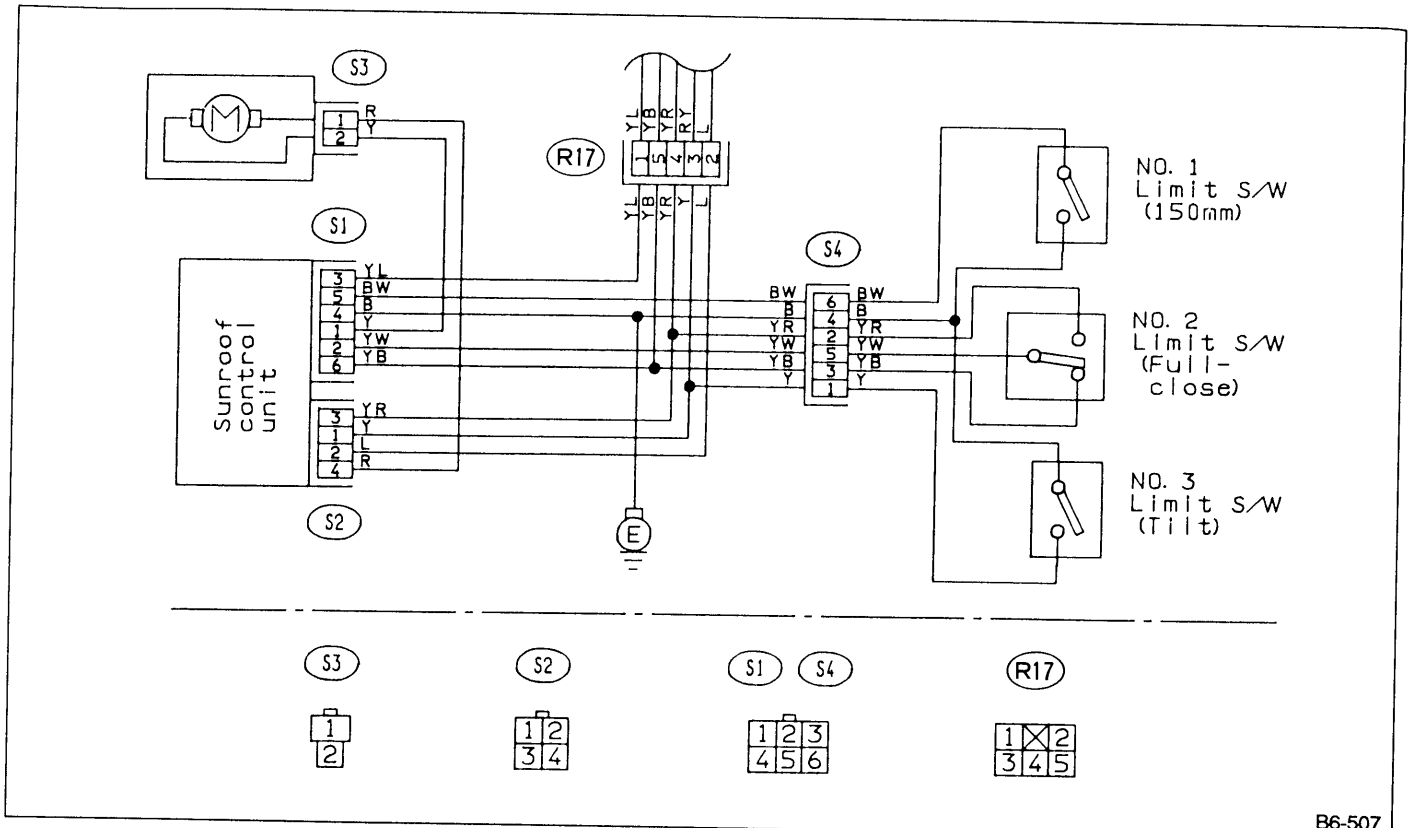


Fig. 58

B6-507

27. RADIO AND POWER ANTENNA

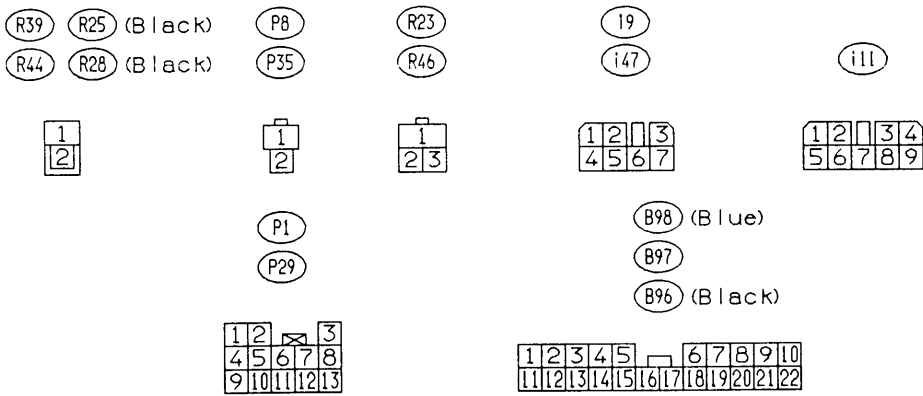
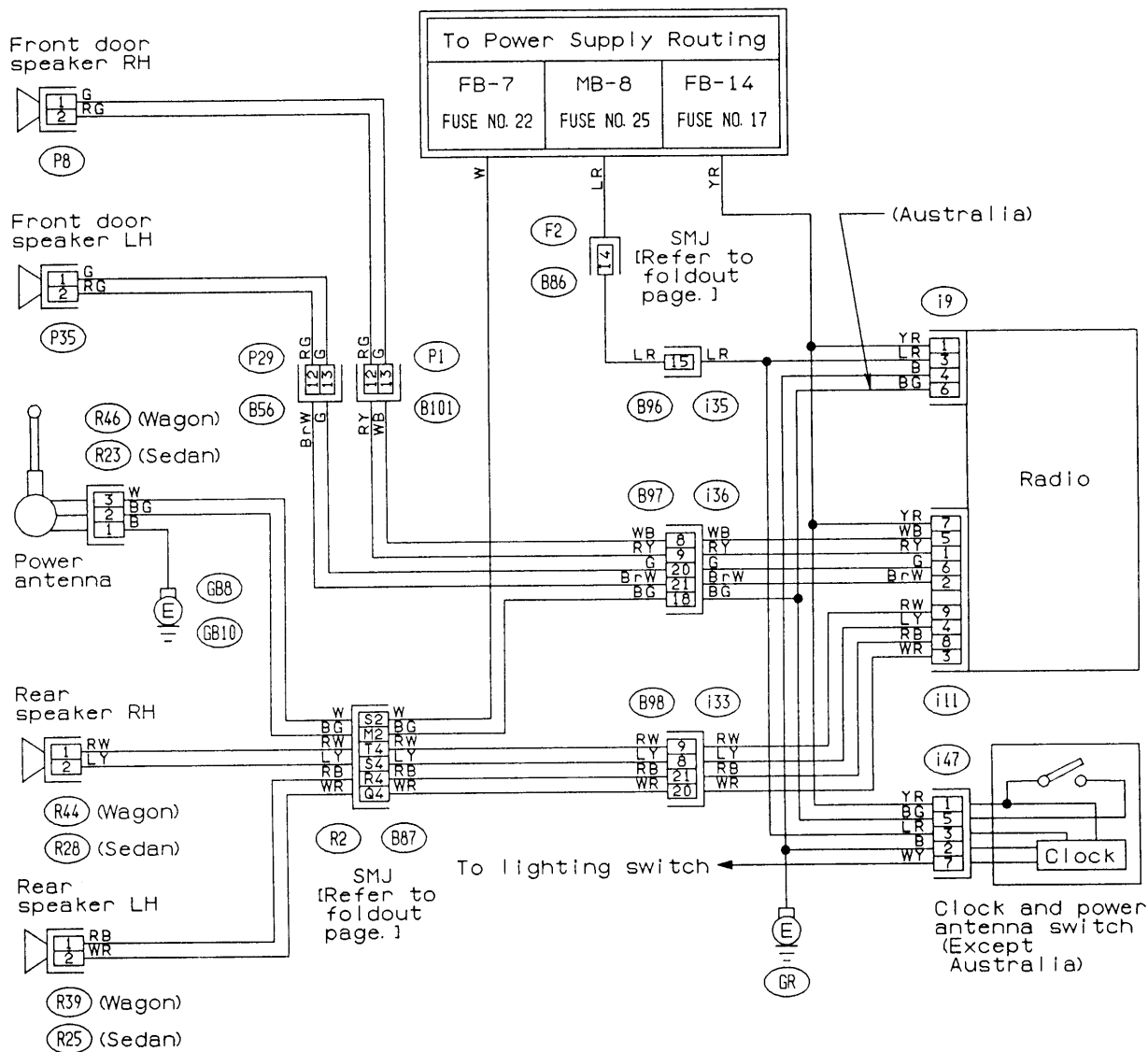


Fig. 59

BR76-02

28. MODE SELECTOR AND BLOWER MOTOR

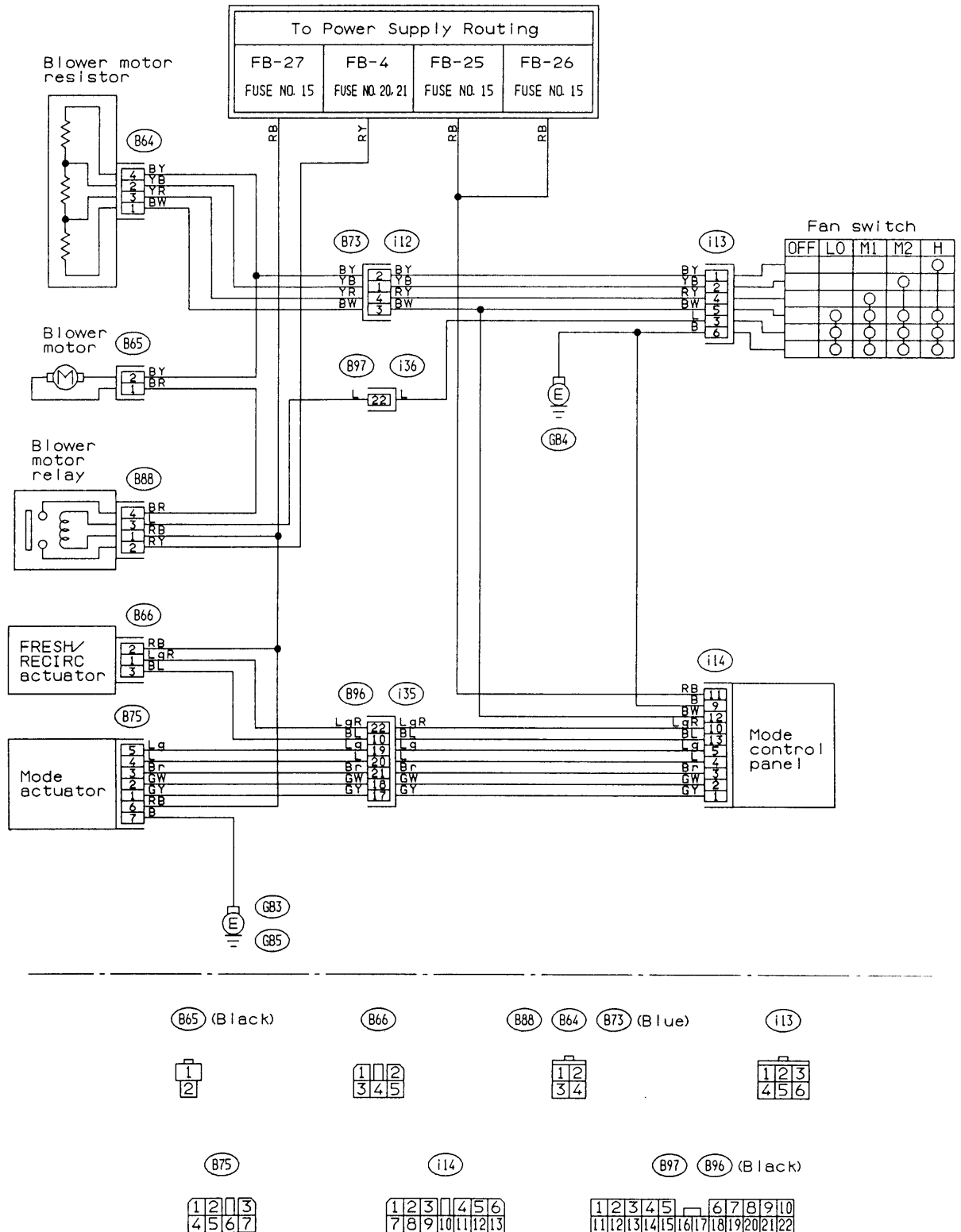


Fig. 60

BR78-02

29. REMOTE CONTROL REARVIEW MIRROR

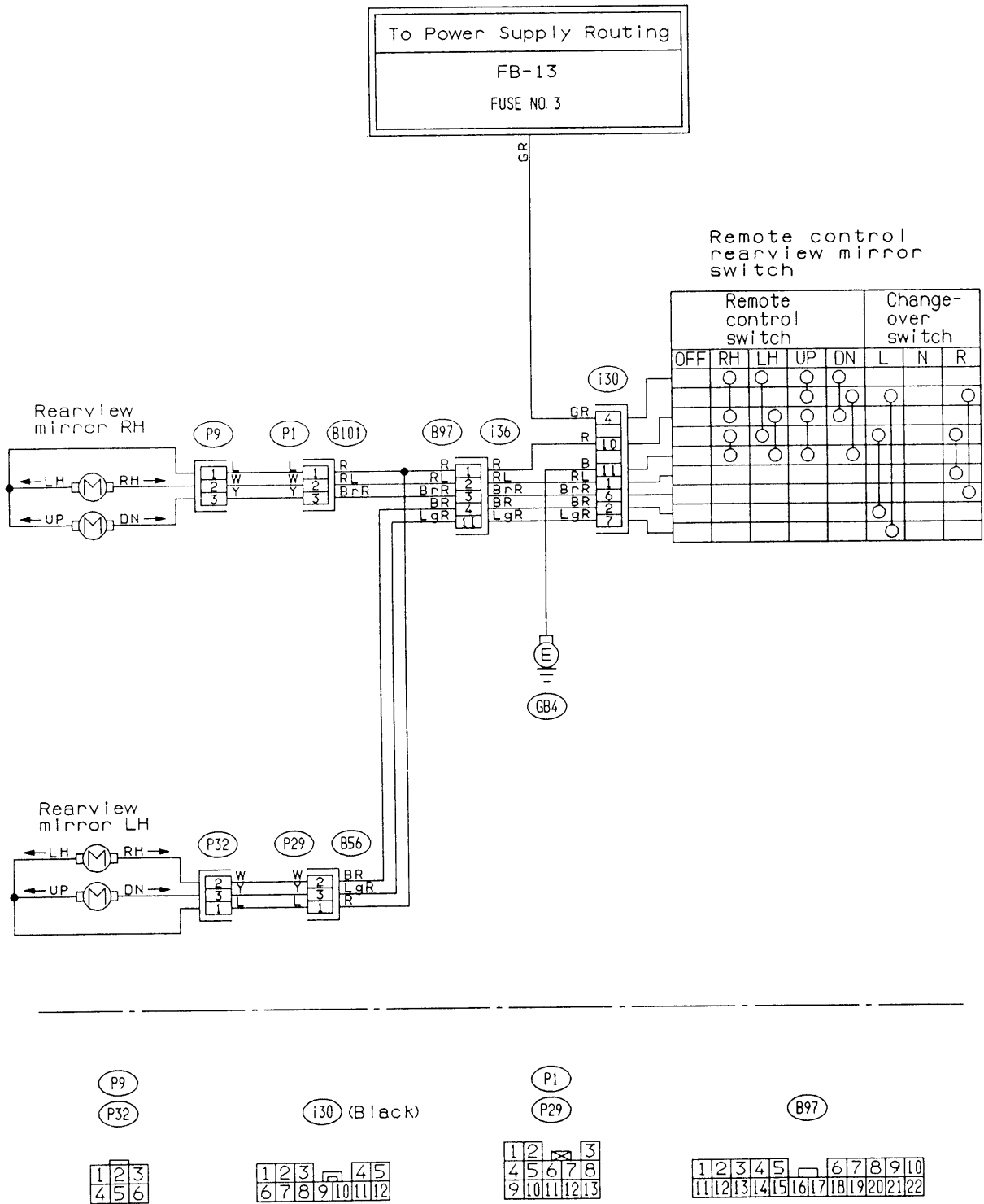


Fig. 61

BR79-02

30. PNEUMATIC (AIR) SUSPENSION

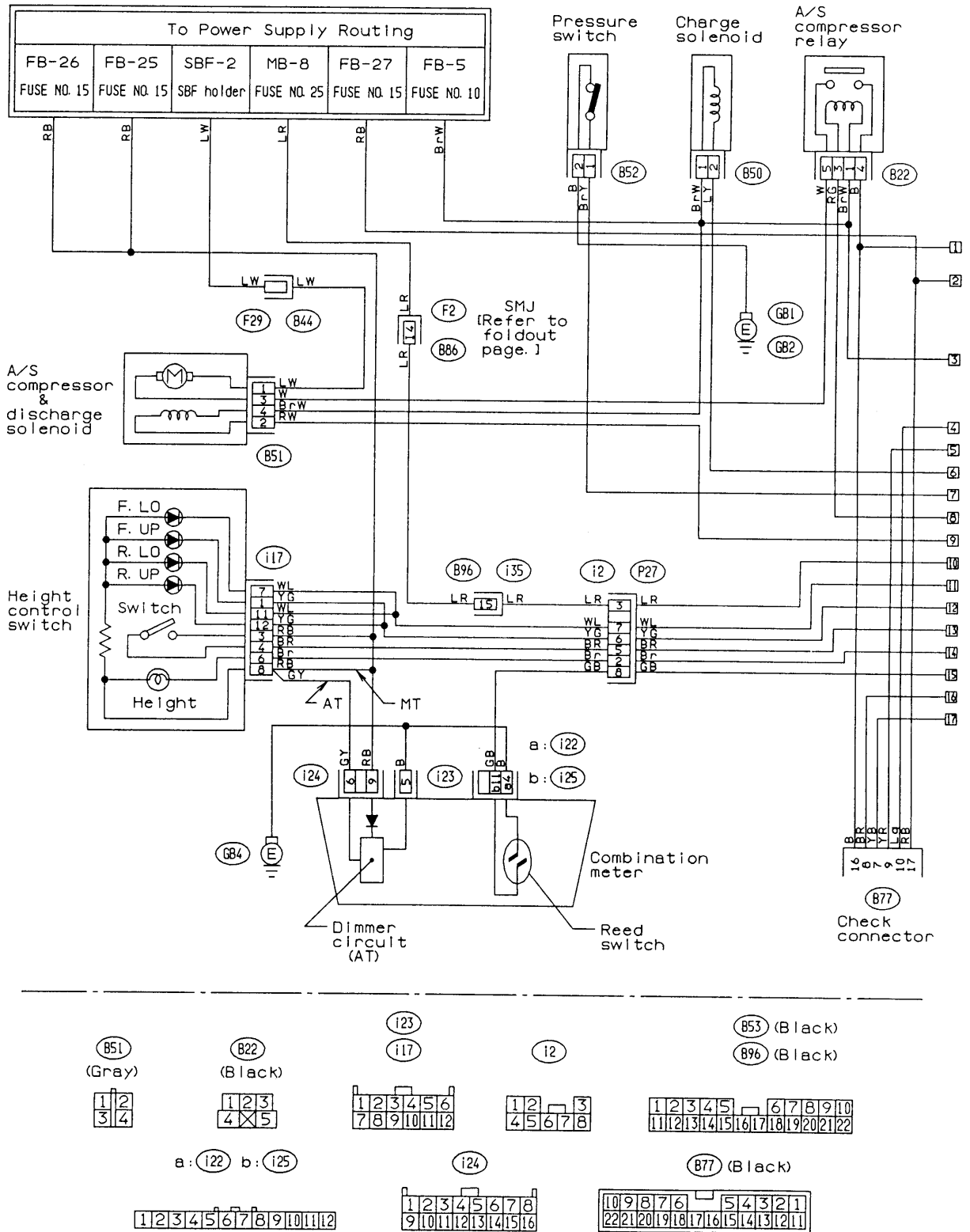
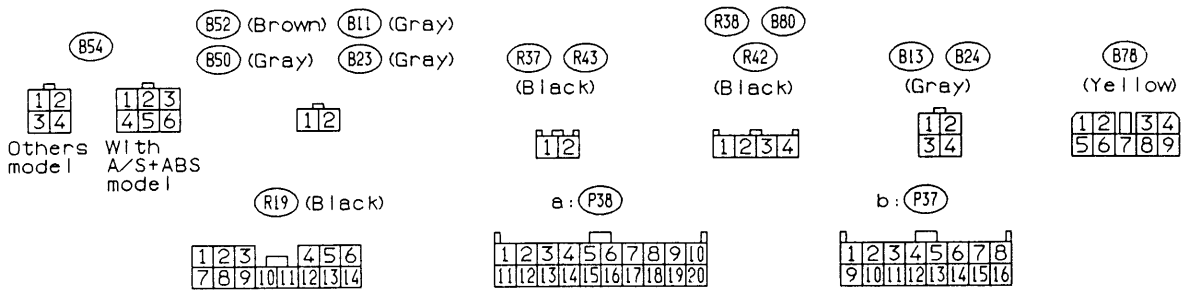
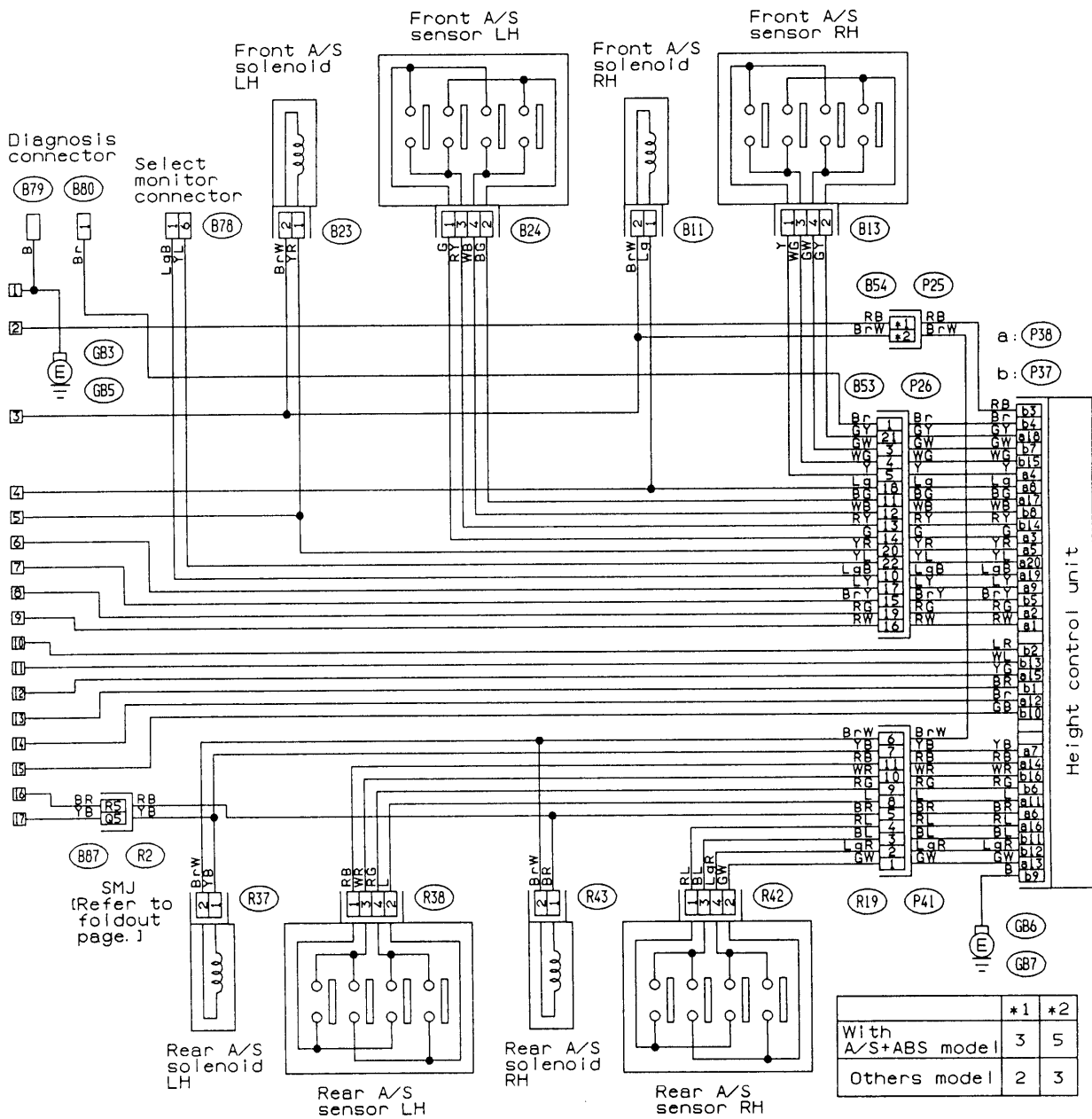


Fig. 62

BR80-03A



BR80-03B

31. ANTILOCK BRAKE SYSTEM

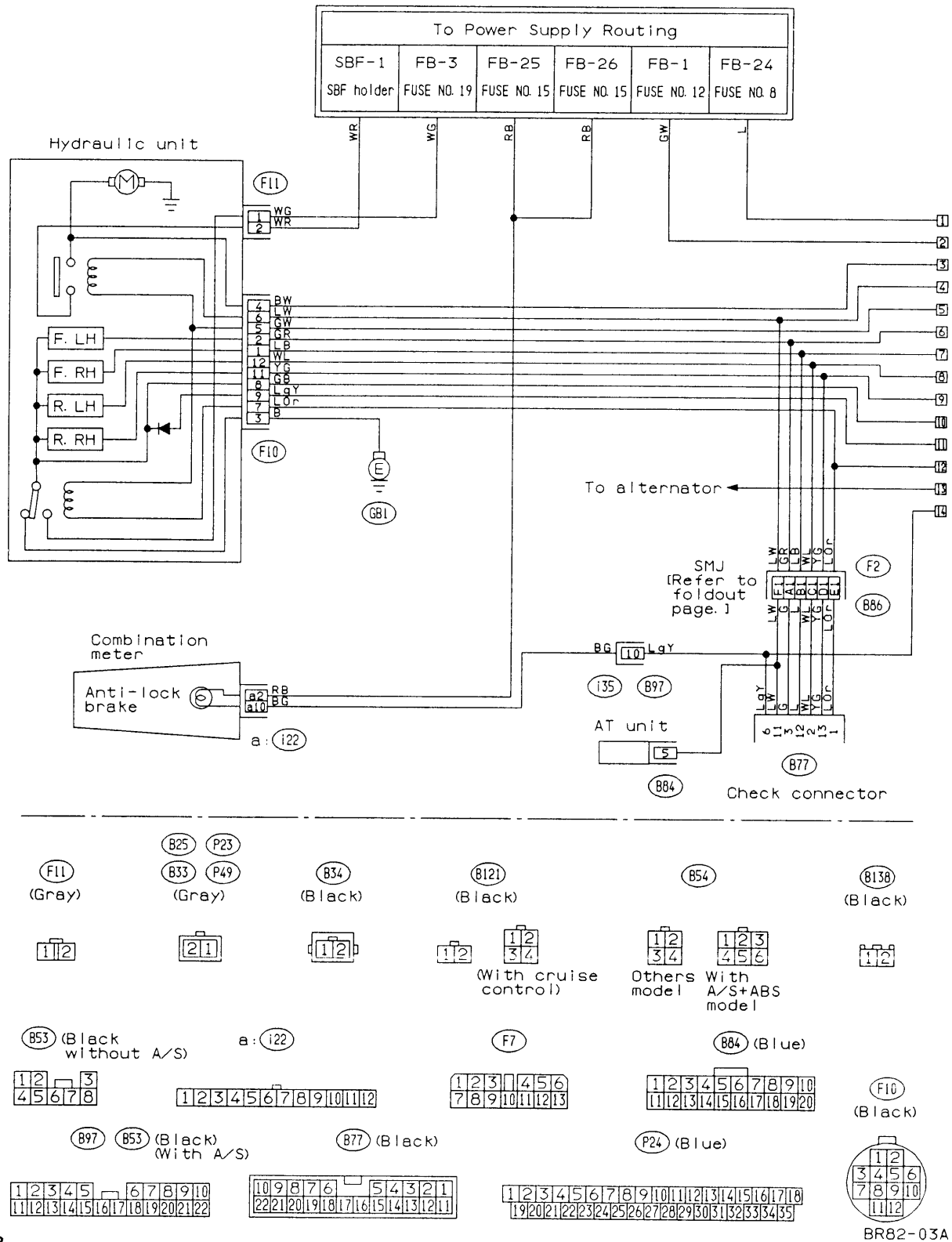
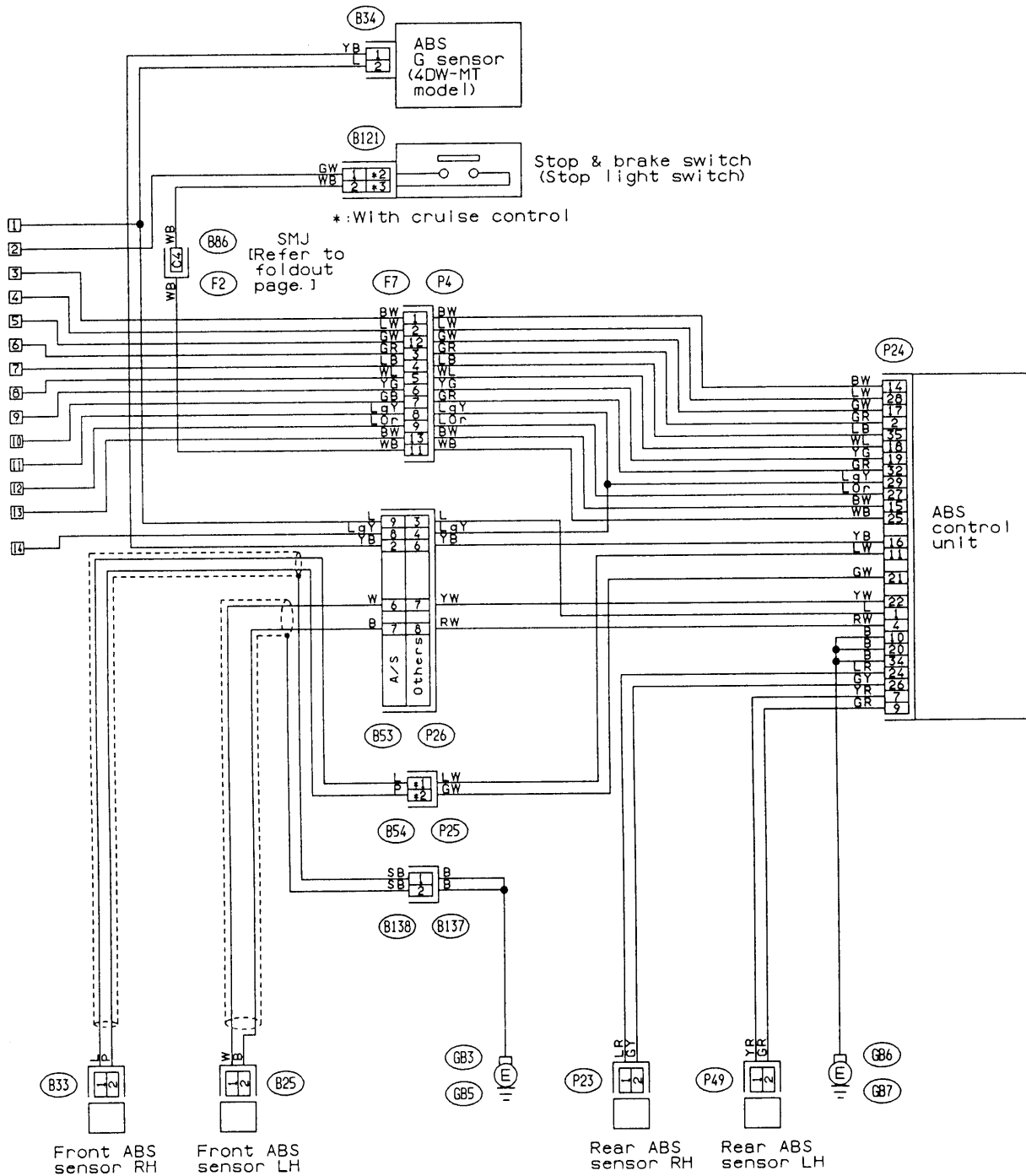


Fig. 63



	*1	*2
With A/S+ABS model	2	6
Others model	1	4

BR82-03B

32. CRUISE CONTROL

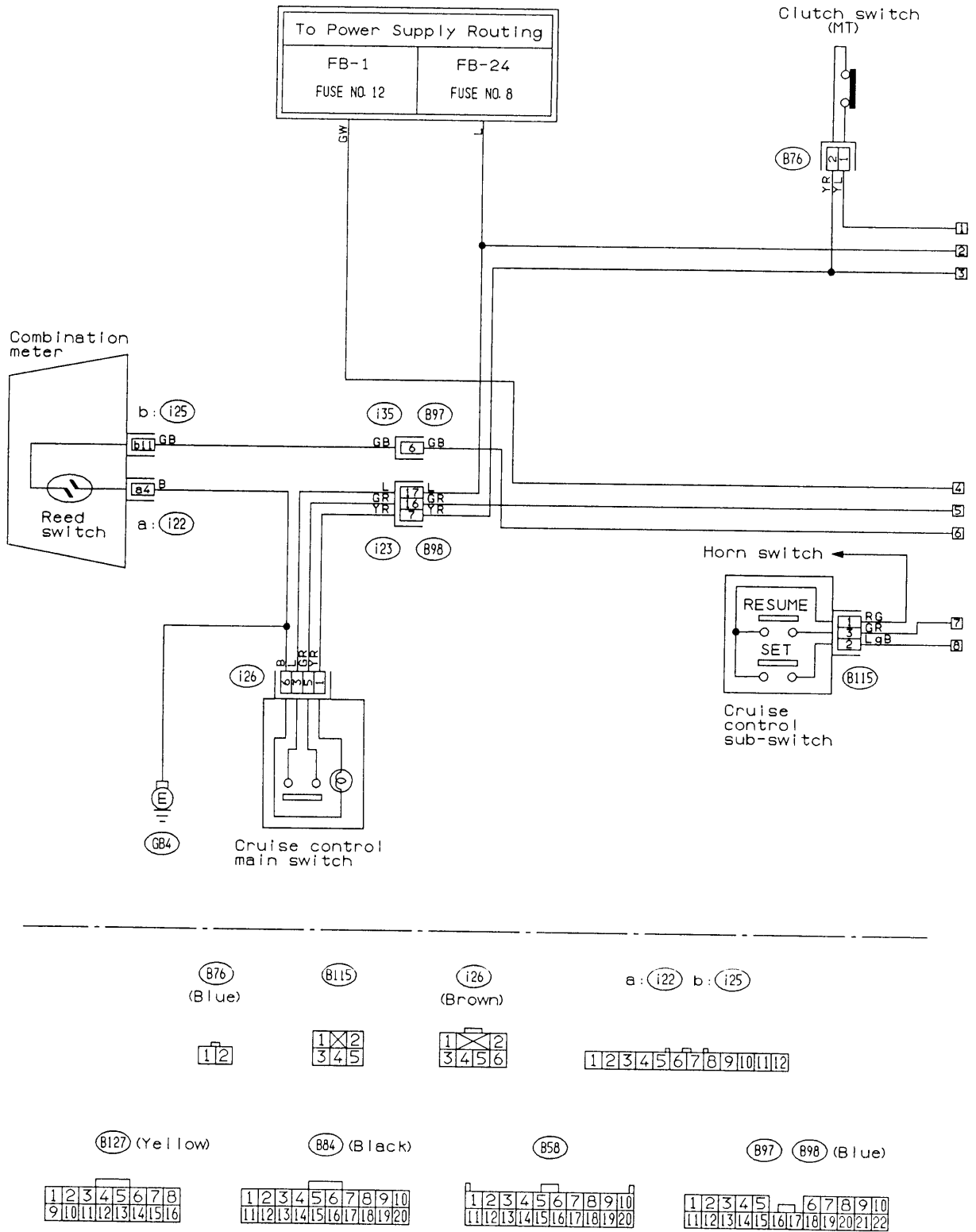
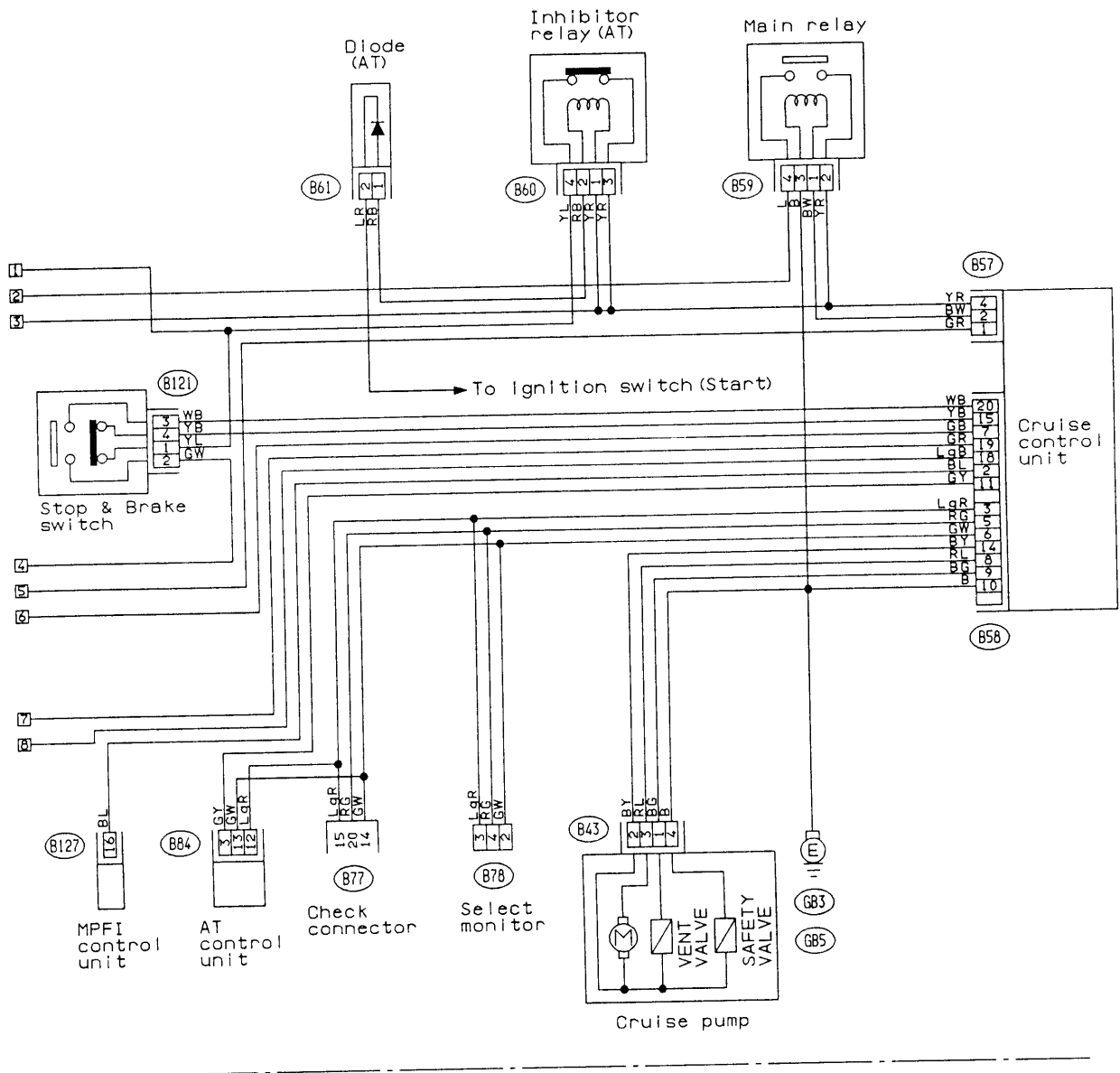


Fig. 64

BR71-03A



(B61) (Black)

(B57)

(B43) (Gray) (B121) (Black)

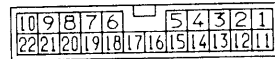
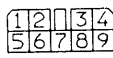


(B59) (Black)

AT: (B60)

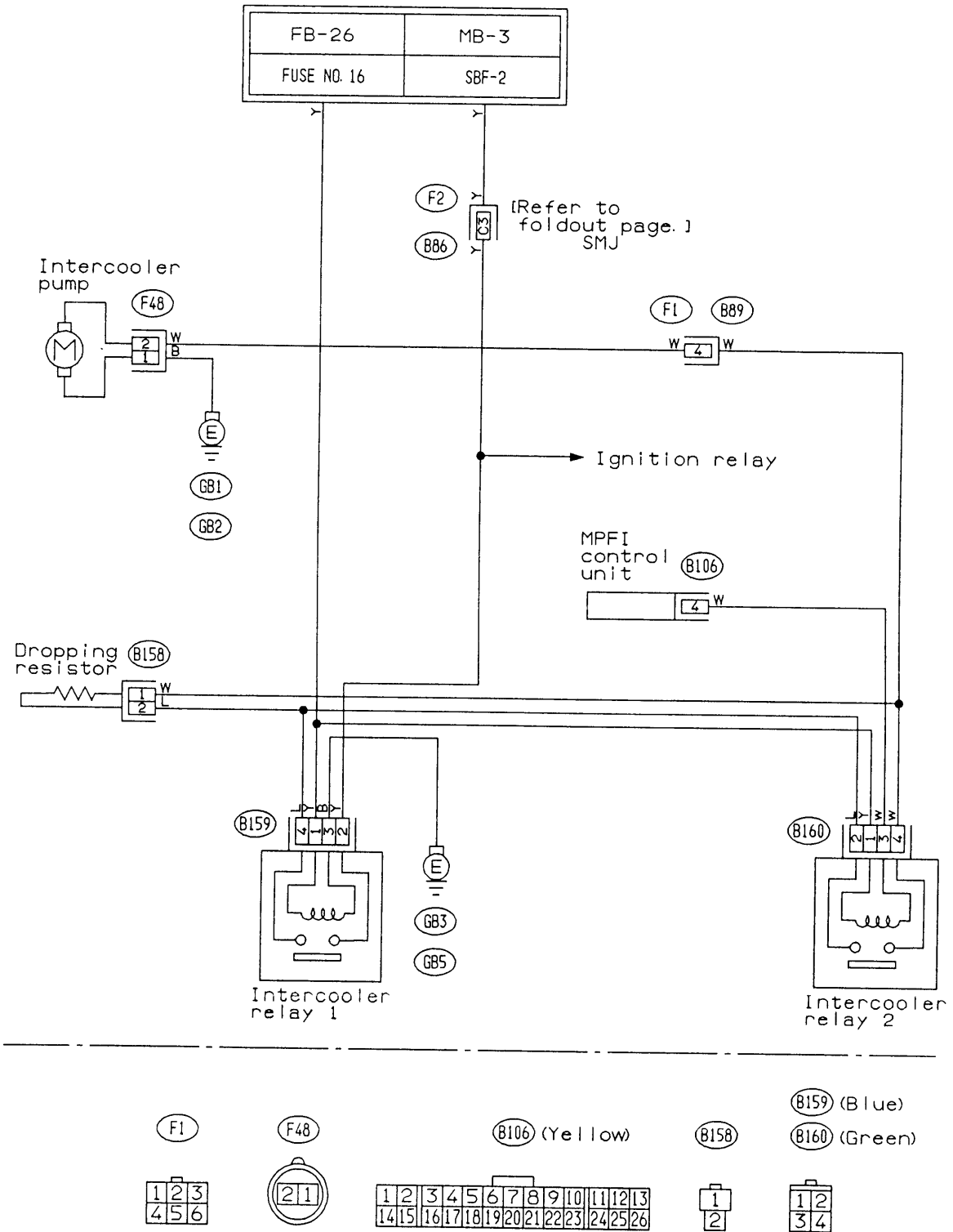
(B78) (Yellow)

(B77) (Black)



BR71-03B

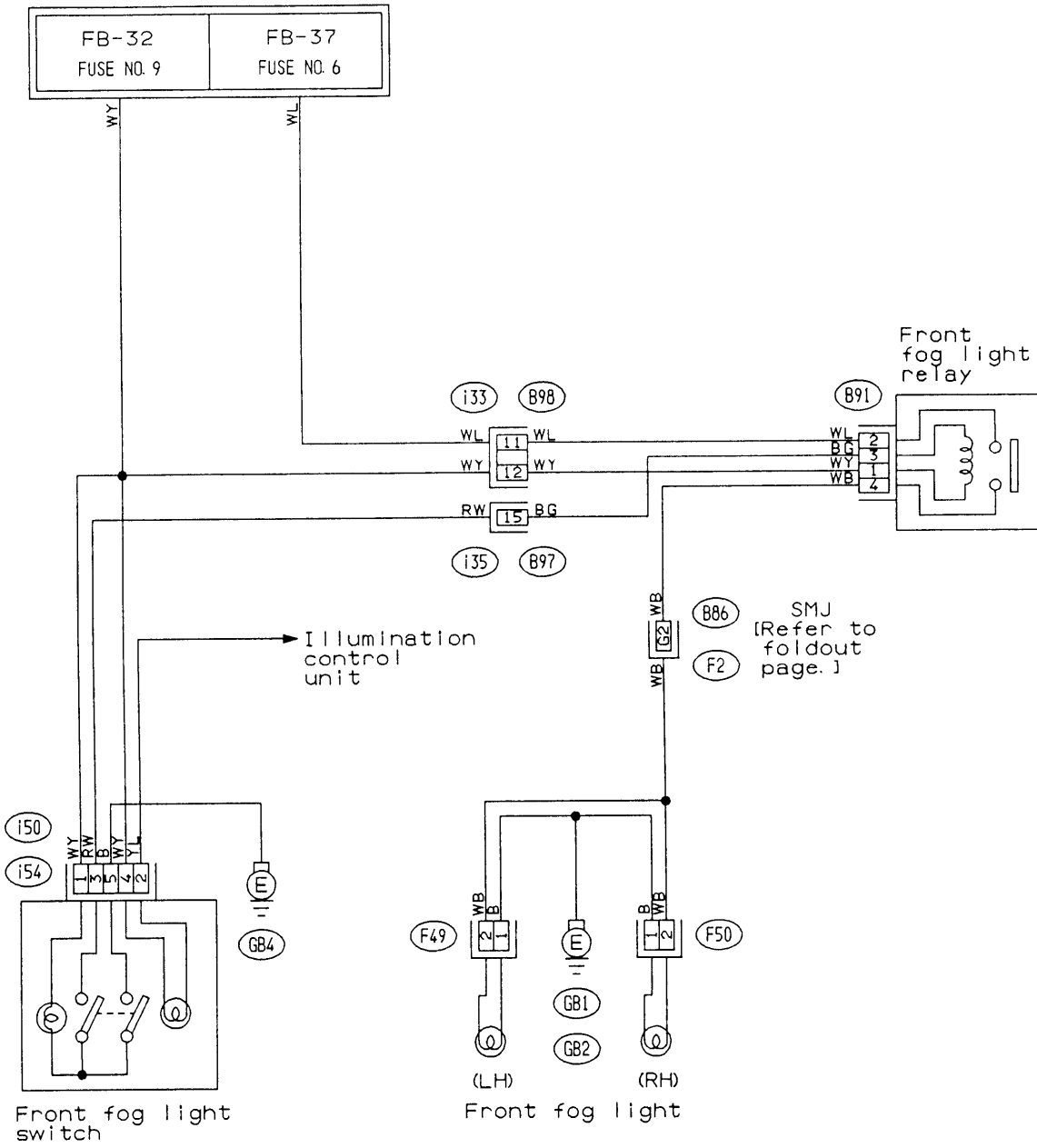
33. INTERCOOLER PUMP



BR12-01

Fig. 65

34. FRONT FOG LIGHT



- (i50) (ADR)
- (F49)
- (B97)
- (B98) (Blue)
- (i54) (Europe)
(Yellow)
- (F50)
- (B91) (Blue)
- (B86) (Blue)
- (F2)

BR22-01

Fig. 66

35. KEYLESS ENTRY

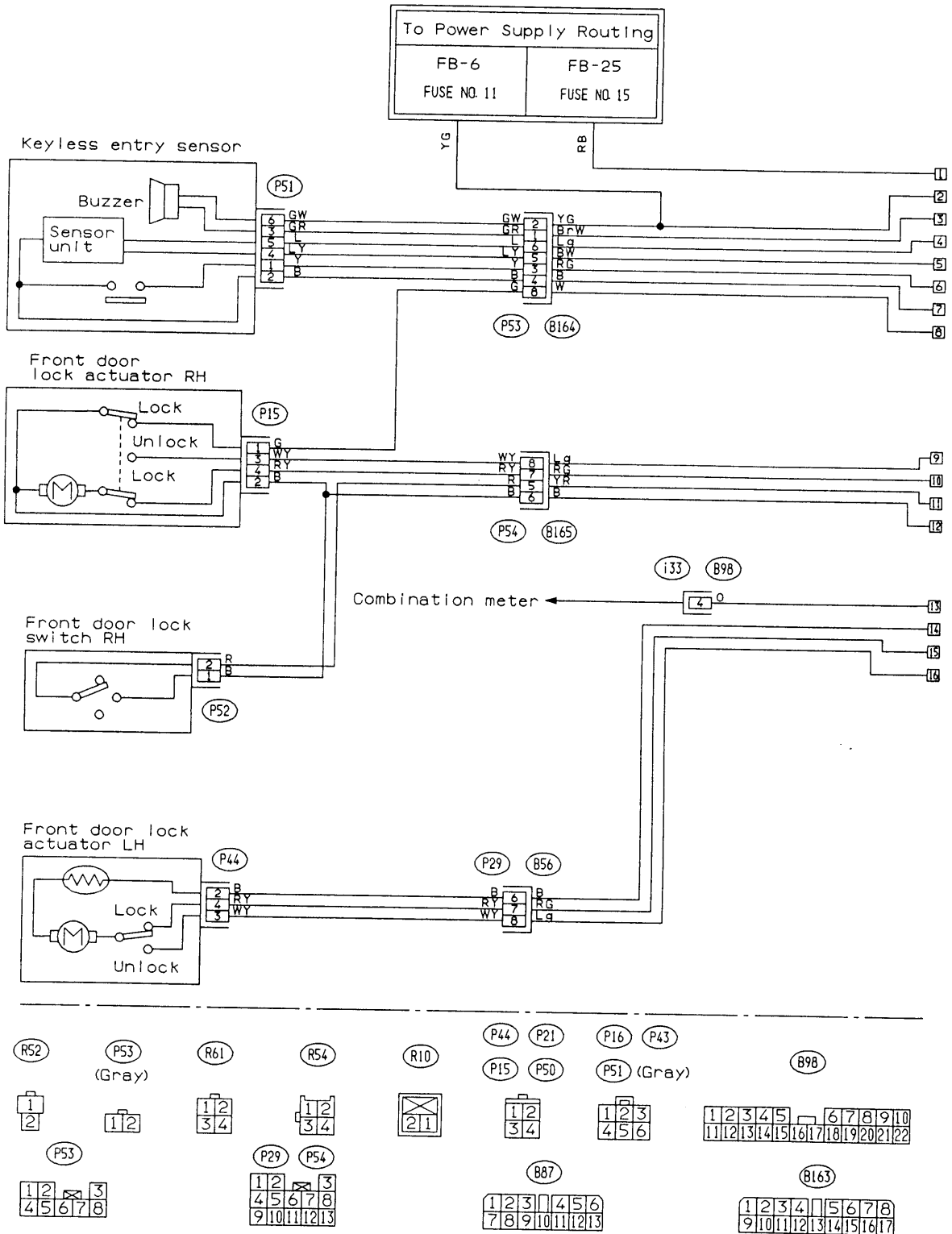
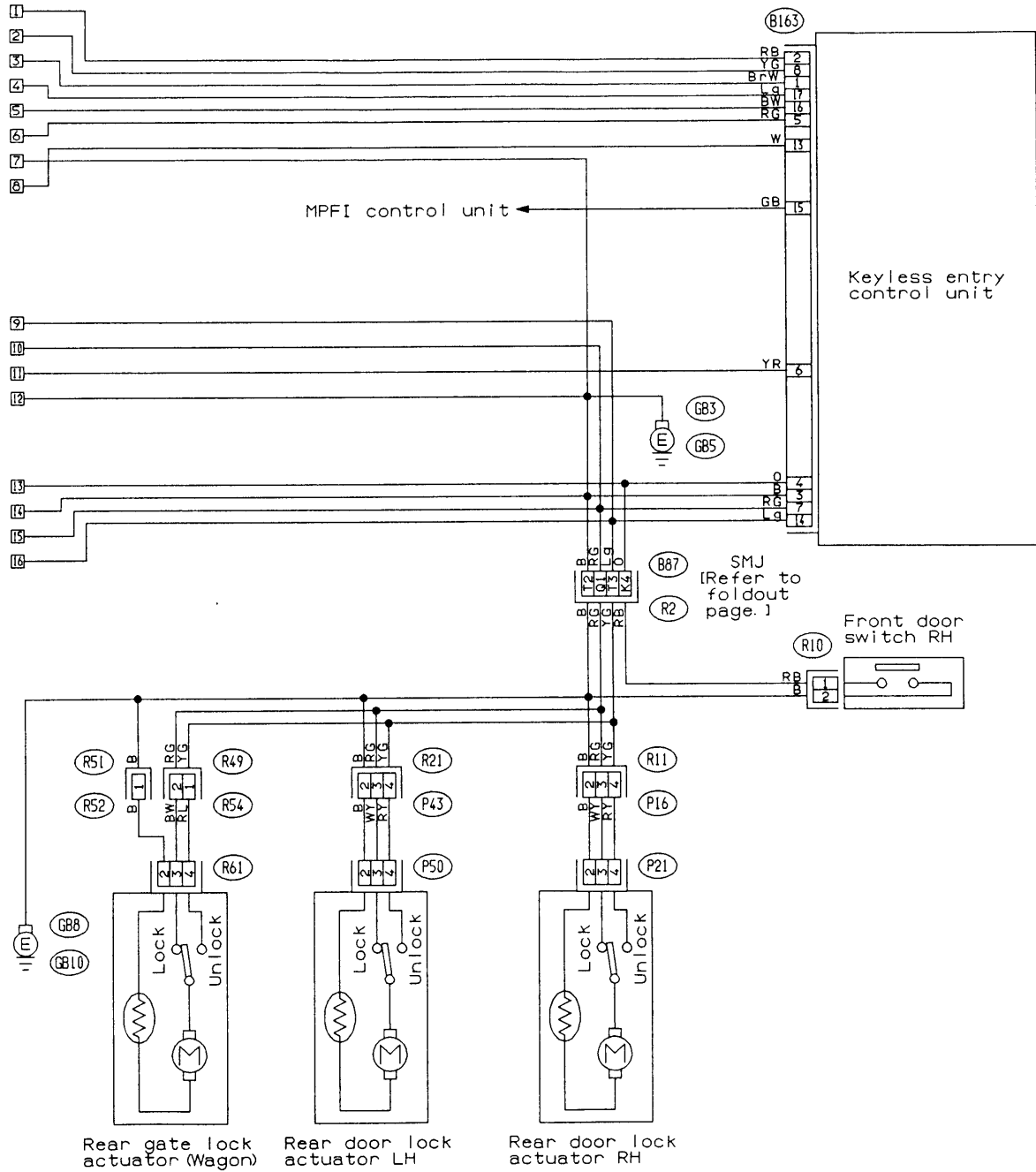


Fig. 67

BR77-01A



BR77-01B

36. HEADLIGHT BEAM LEVELER

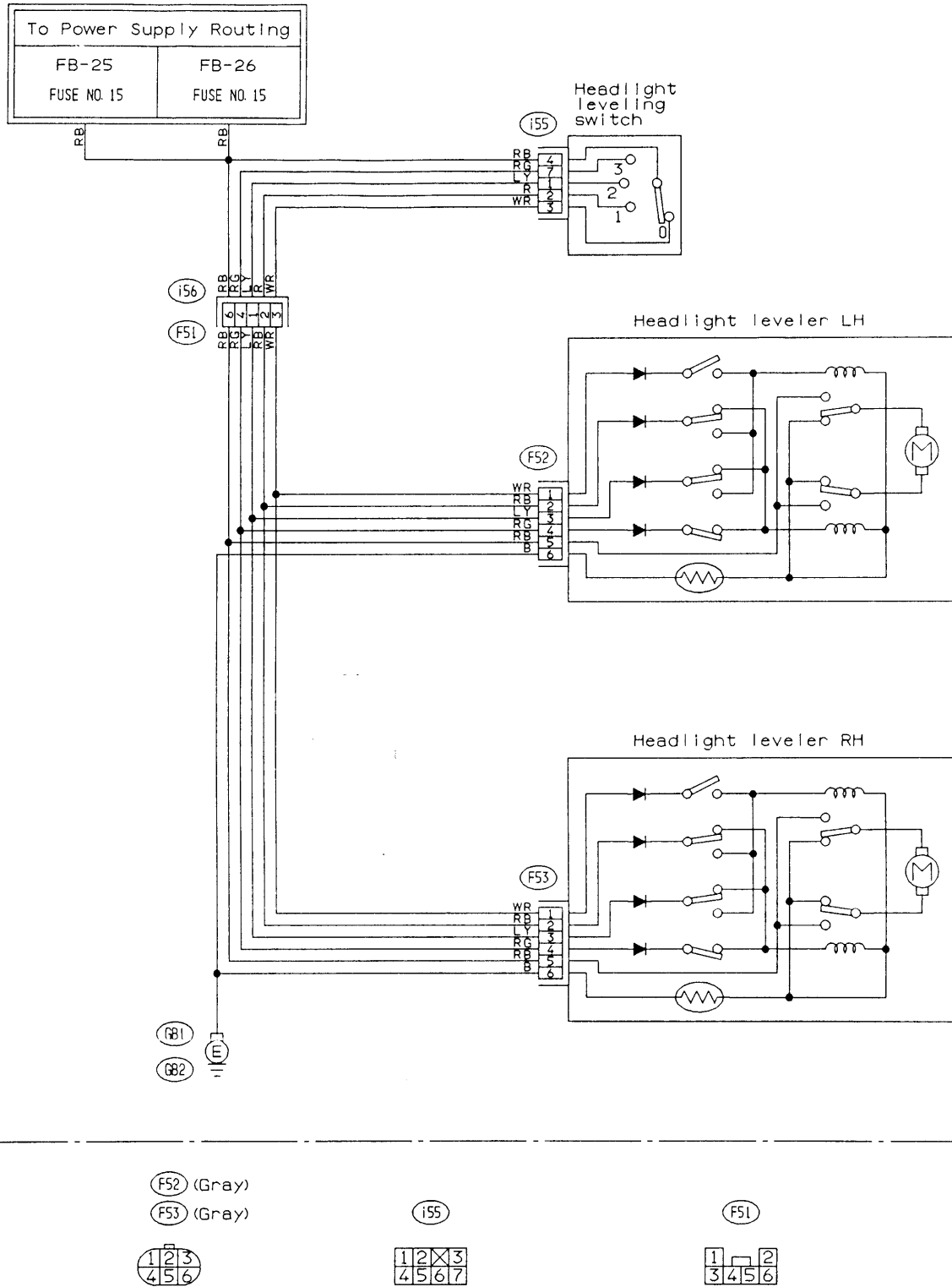


Fig. 68

BR83-01

6. Electrical Unit Location

	Page		Page
Sec. 1 RELAY	92	Sec. 5 DIODE•CONDENSER	104
Sec. 2 CONTROL UNIT	95	Sec. 6 FUSE AND FUSIBLE LINK	106
Sec. 3 SWITCH	97	Sec. 7 SELECT MONITOR CONNECTOR AND CHECK CONNECTOR	107
Sec. 4 SENSOR•VALVE•SOLENOID•ETC.	99		

Electrical Unit	Refer to
	Sec.
ABS control unit	2
ABS G-sensor	4
A/S compressor relay	1
A/C cut relay	1
A/C main fan relay	1
A/C pressure switch	3
A/C relay	1
A/C sub fan relay	1
A/C sub fan water temperature relay	1
A/S charge solenoid	4
A/S compressor	4
A/S control unit	2
A/S pressure switch	3
AT control unit (4AT)	2
Back-up light switch	3
Blower motor resistor	4
Blower relay	1
By-pass air control valve	4
Cam angle sensor	4
Check connector	7
Condenser (Horn)	5
Condenser (Rear defogger)	5
CPC solenoid	4
Crank angle sensor	4
Cruise control	2
Diagnosis connector	7
Diagnosis connector (Ground)	7
Diode (For Door warning)	5
Diode (For Lighting)	5
Dropping resistor	4
Evaporator thermoswitch	3
Fuel gauge unit	4
Fuel pump relay	1
Fuse and fusible link	6
FWD switch	3

Electrical Unit	Refer to
	Sec.
Headlight relay LH	1
Headlight relay RH	1
Horn relay	1
Igniter	4
Ignition relay	1
Illumination control unit	2
Intercooler relay	1
Knock sensor	4
Main fan relay	1
MPFI control unit	2
Mode actuator	4
Neutral switch	3
Oil pressure switch	3
O ₂ sensor	4
Pressure exchange solenoid valve	4
Pressure sensor	4
P/W relay	1
P/W circuit breaker	4
Read memory connector	7
Rear defogger relay	1
Rear wiper intermittent unit	2
Select monitor connector	7
Stop light switch	3
Sunroof control unit	2
Front fog light relay	1
Tail and illumination relay	1
Test mode connector	7
Thermometer	4
Throttle sensor	4
Turn signal and Hazard unit	2
Vehicle speed sensor	4
Wastegate control solenoid valve	4
Water temperature sensor	4

Sec. 1 RELAY

A/C cut relay	Fig. 69-1
A/C main fan relay	Fig. 68-2
A/C relay	Fig. 68-2
A/C sub fan relay	Fig. 68-2
A/C sub fan water temperature relay	Fig. 68-2
A/S compressor relay	Fig. 68-1
Blower relay	Fig. 69-2
Fuel pump relay	Fig. 69-2
Headlight relay LH	Fig. 68-2

Headlight relay RH	Fig. 68-2
Horn relay	Fig. 69-3
Ignition relay	Fig. 69-2
Main fan relay	Fig. 69-4
P/W relay	Fig. 70-1
Rear defogger relay	Fig. 69-4
Front fog light relay	Fig. 69-2
Tail and illumination relay	Fig. 69-4
Intercooler relay	Fig. 68-3

(1) Engine Room

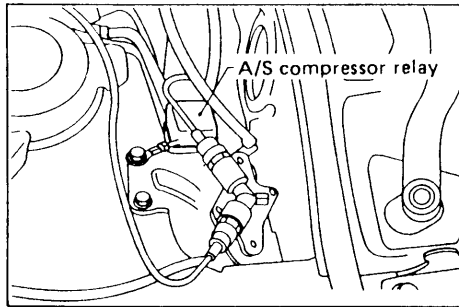


Fig. 69-1 B6-304

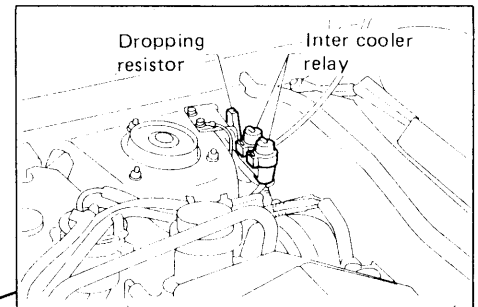


Fig. 69-3 B6-755

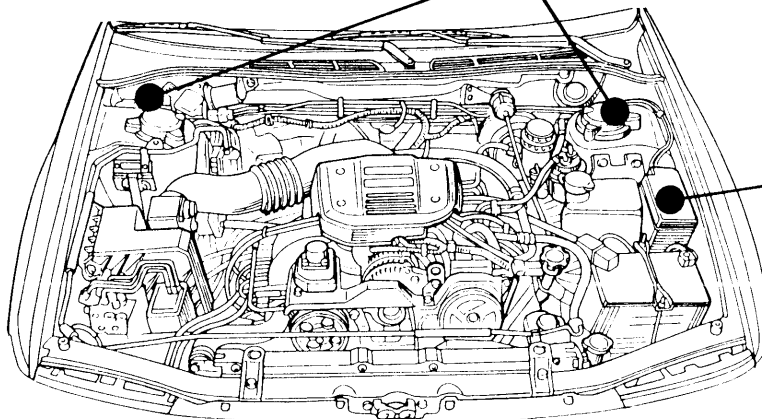


Fig. 69

B6-718

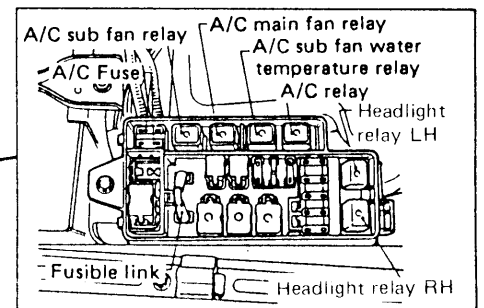


Fig. 69-2

B6-339

(2) Instrument Panel

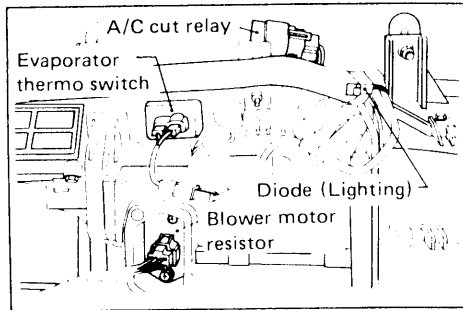


Fig. 70-1

B6-582

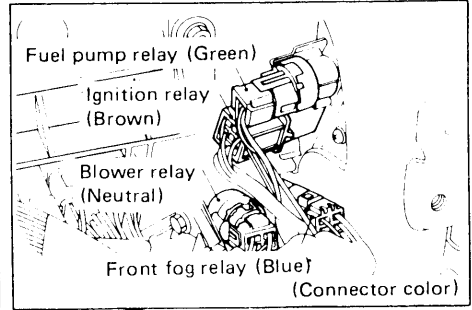


Fig. 70-2

B6-756

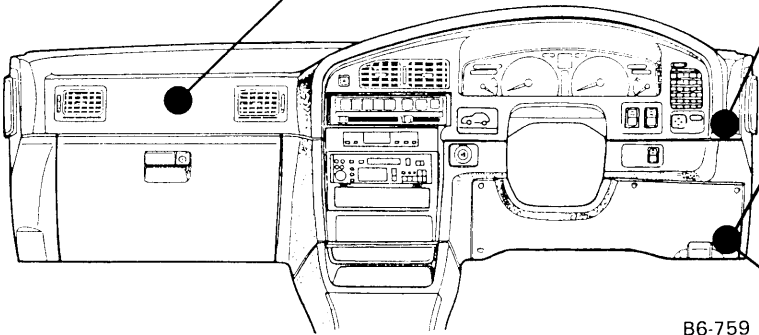


Fig. 70

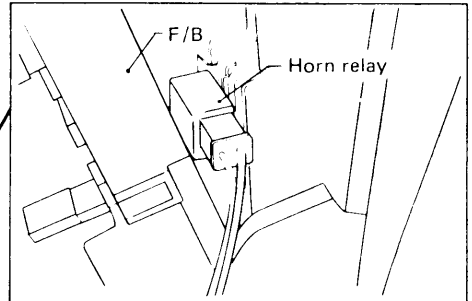


Fig. 70-3

B6-585

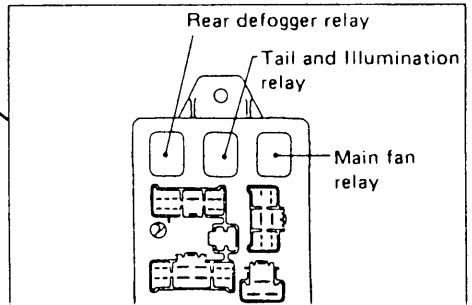


Fig. 70-4

B6-311

(3) Compartment

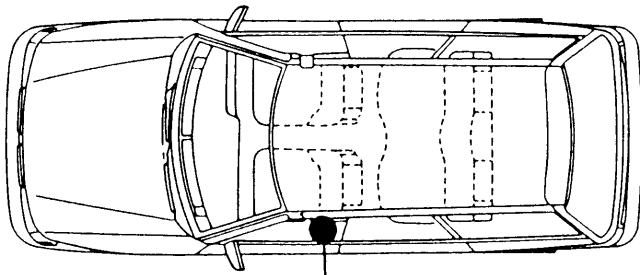


Fig. 71

B6-331

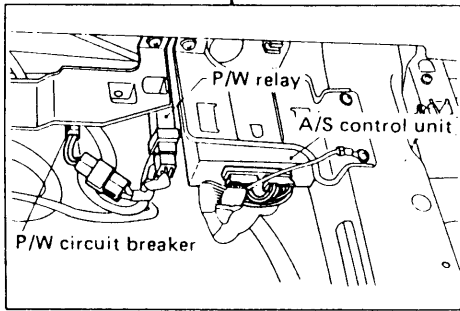


Fig. 71-1

B6-295

Sec. 2 CONTROL UNIT

ABS control unit	Fig. 72-1	Illumination control unit	Fig. 71-4
A/S control unit	Fig. 72-3	MPFI control unit	Fig. 71-3
AT control unit (4AT)	Fig. 71-2	Sunroof control unit	Fig. 72-2
Cruise control unit	Fig. 71-1	Turn signal and Hazard unit	Fig. 71-4

(1) Instrument Panel

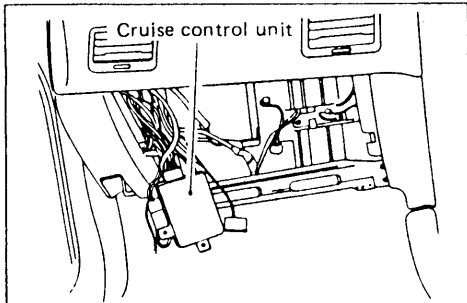


Fig. 72-1

B6-587

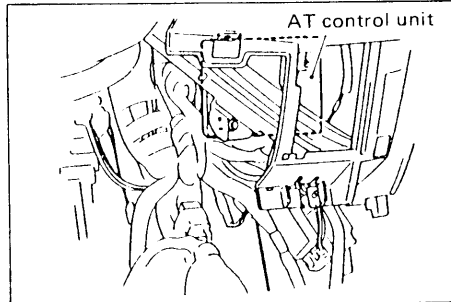


Fig. 72-2

B6-586

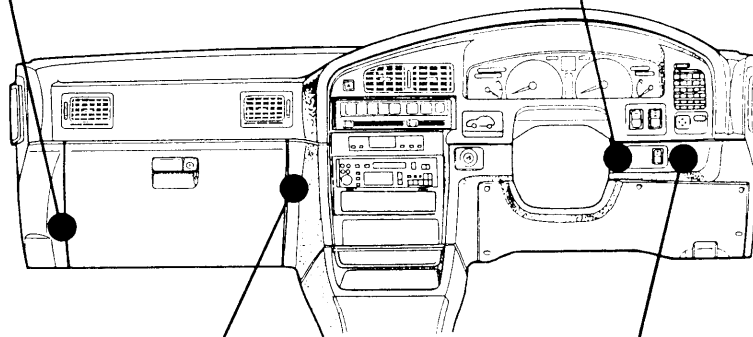


Fig. 72

B6-759

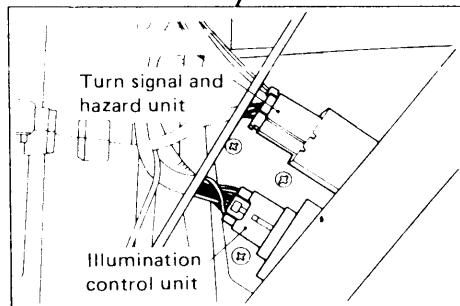


Fig. 72-4

B6-588

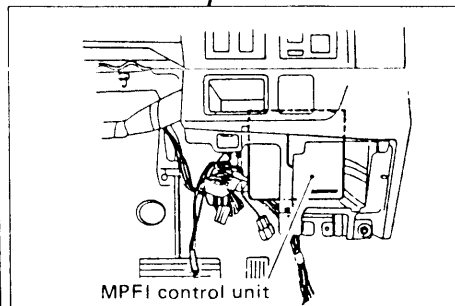


Fig. 72-3

B6-589

(2) Compartment

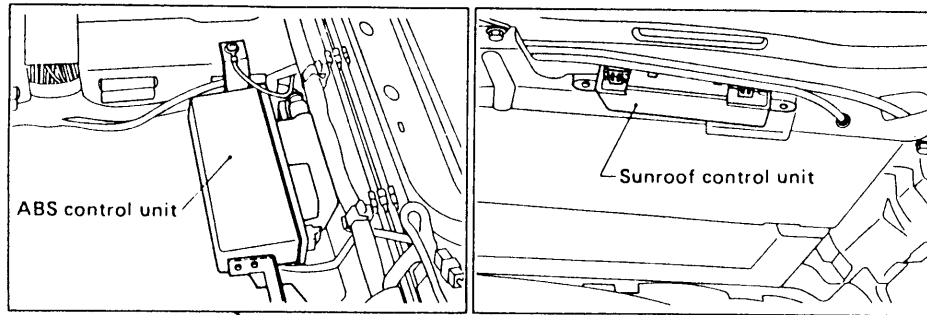


Fig. 73-1

B6-293

Fig. 73-2

B6-313

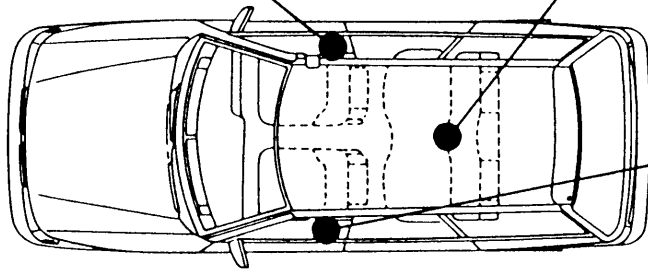


Fig. 73

B6-331A

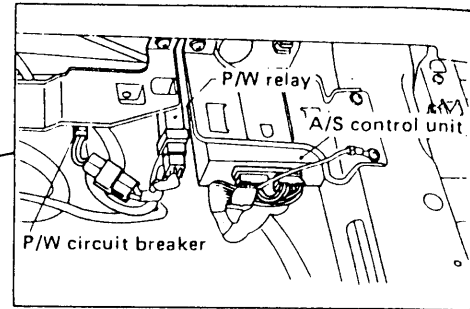


Fig. 73-3

B6-295

(3) Luggage Room

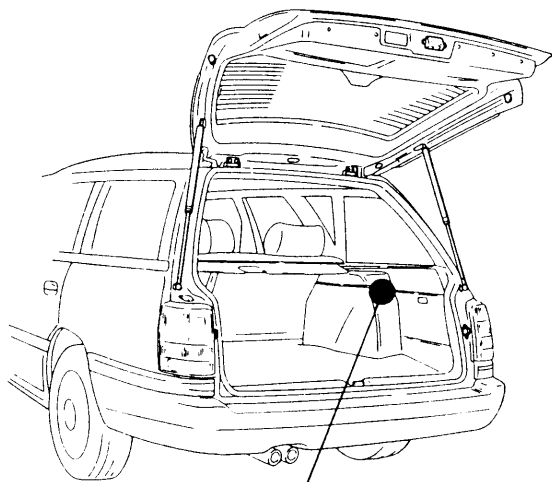


Fig. 74

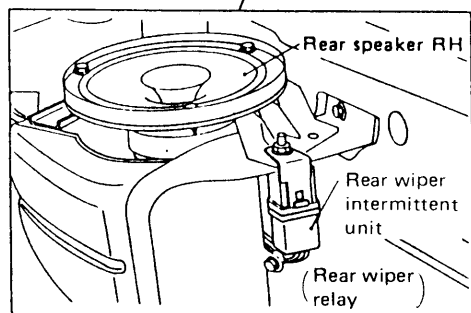


Fig. 74-1

B6-757

Sec. 3 SWITCH

A/C pressure switch	Fig. 74-1	FWD switch	Fig. 74-2
A/S pressure switch	Fig. 74-4	Neutral switch	Fig. 74-3
Back-up light switch	Fig. 74-3	Oil pressure switch	Fig. 74-5
Evaporator thermoswitch	Fig. 75-2	Stop light switch	Fig. 75-1

(1) Engine Room

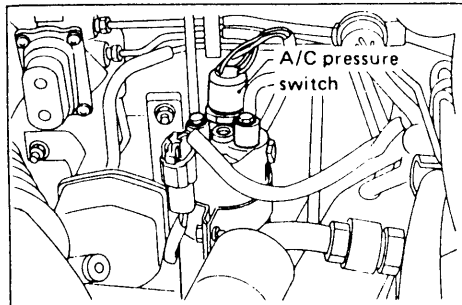


Fig. 75-1

B6-297

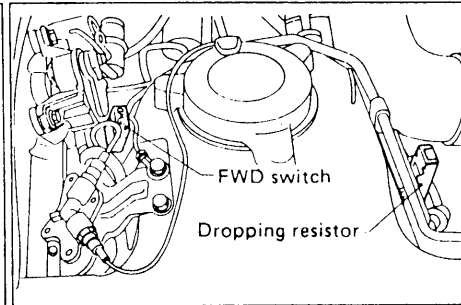


Fig. 75-2

B6-305

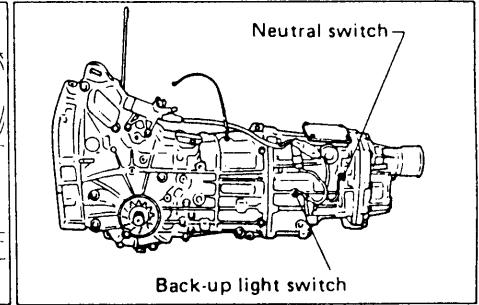


Fig. 75-3

B6-343

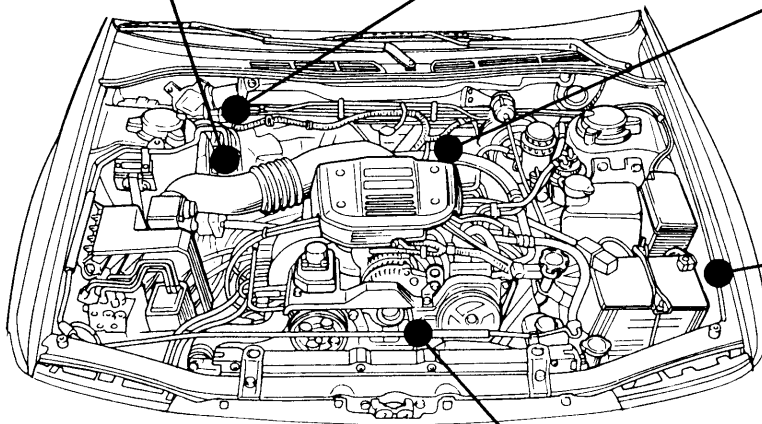


Fig. 75

B6-718A

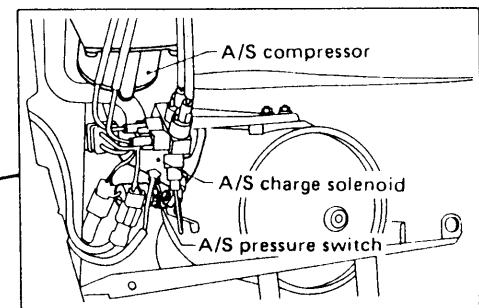


Fig. 75-4

B6-315

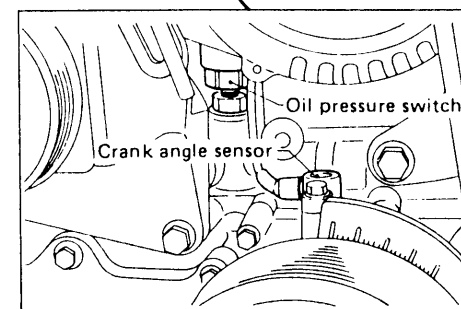
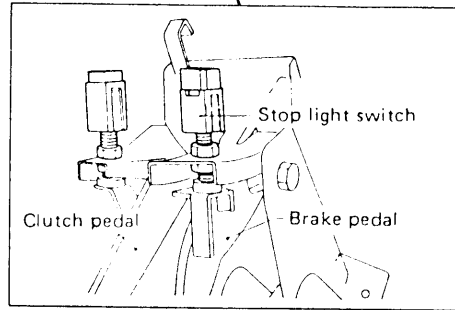
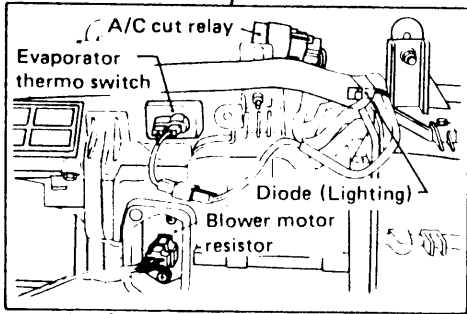
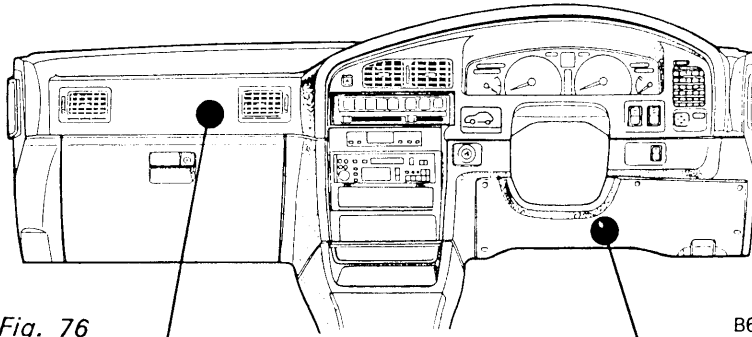


Fig. 75-5

B6-334

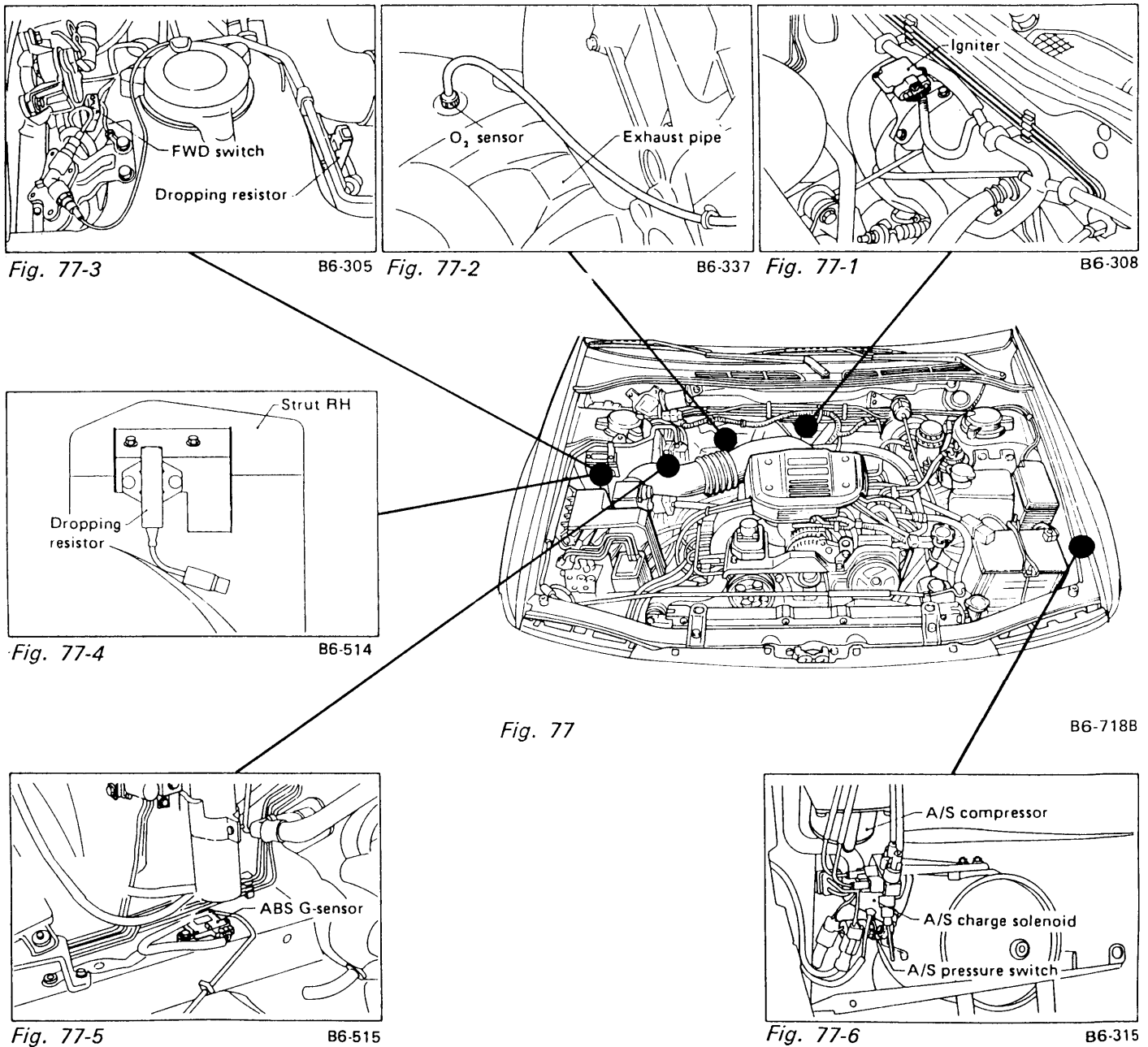
(2) Instrument Panel



Sec. 4 SENSOR•VALVE•SOLENOID•ETC.

ABS G-sensor	Fig. 76-5	Fuel gauge unit	Fig. 80-1
A/S charge solenoid	Fig. 76-6	Igniter	Fig. 76-1
A/S compressor	Fig. 76-6	Knock sensor	Fig. 77-4
Blower motor resistor	Fig. 80-2	Mode actuator	Fig. 80-3
By-pass air control valve	Fig. 77-2	P/W circuit breaker	Fig. 80-4
Cam angle sensor	Fig. 77-5	O ₂ sensor	Fig. 76-2
CPC solenoid	Fig. 77-1	Thermometer	Fig. 77-2
Crank angle sensor	Fig. 77-6	Throttle sensor	Fig. 77-3
Dropping resistor	Fig. 76-4	Water temperature sensor	Fig. 77-2

(1) Engine Room (NA model)



(2) Engine (NA model)

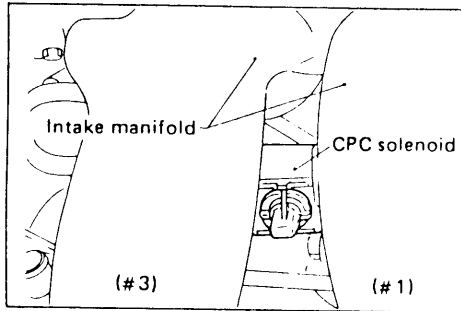


Fig. 78-1

B6-338

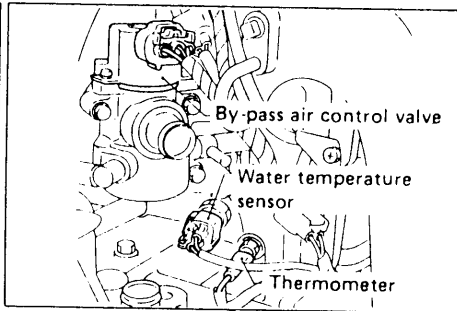


Fig. 78-2

B6-310

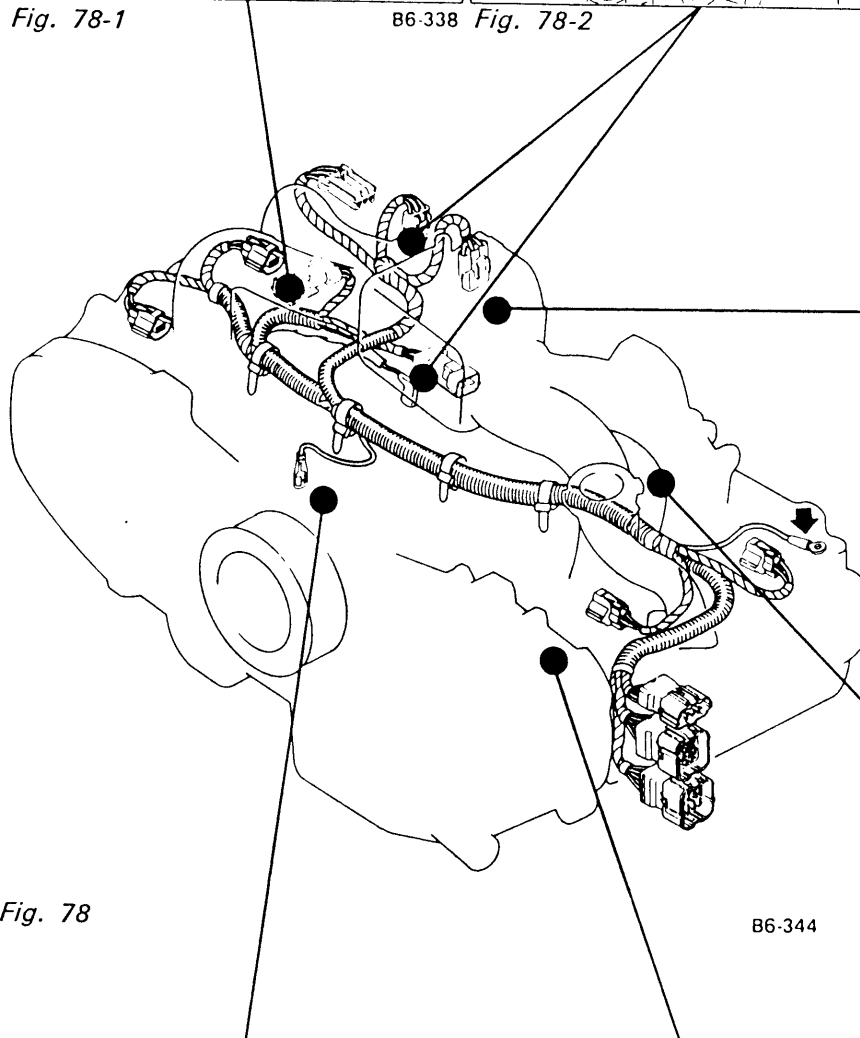


Fig. 78

B6-344

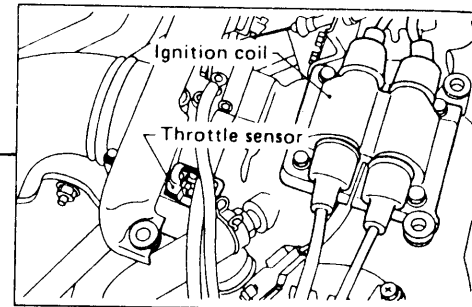


Fig. 78-3

B6-309

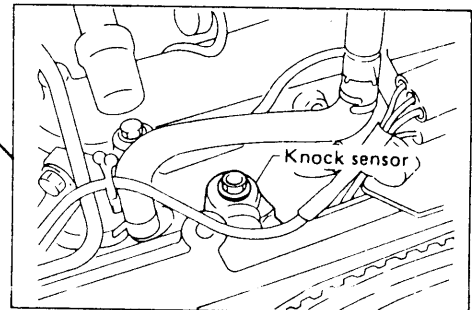


Fig. 78-4

B6-336

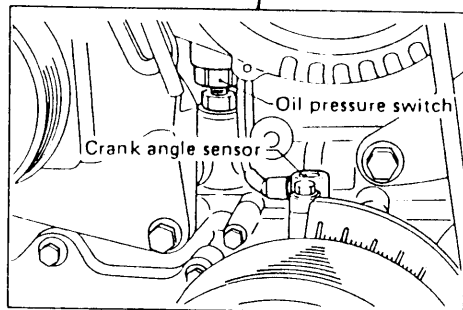


Fig. 78-6

B6-334

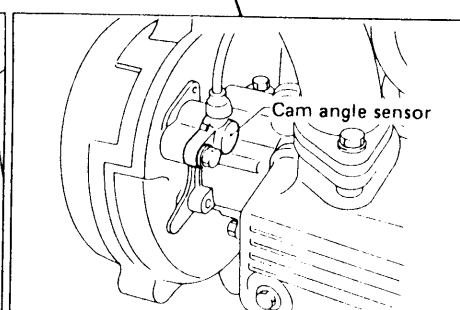
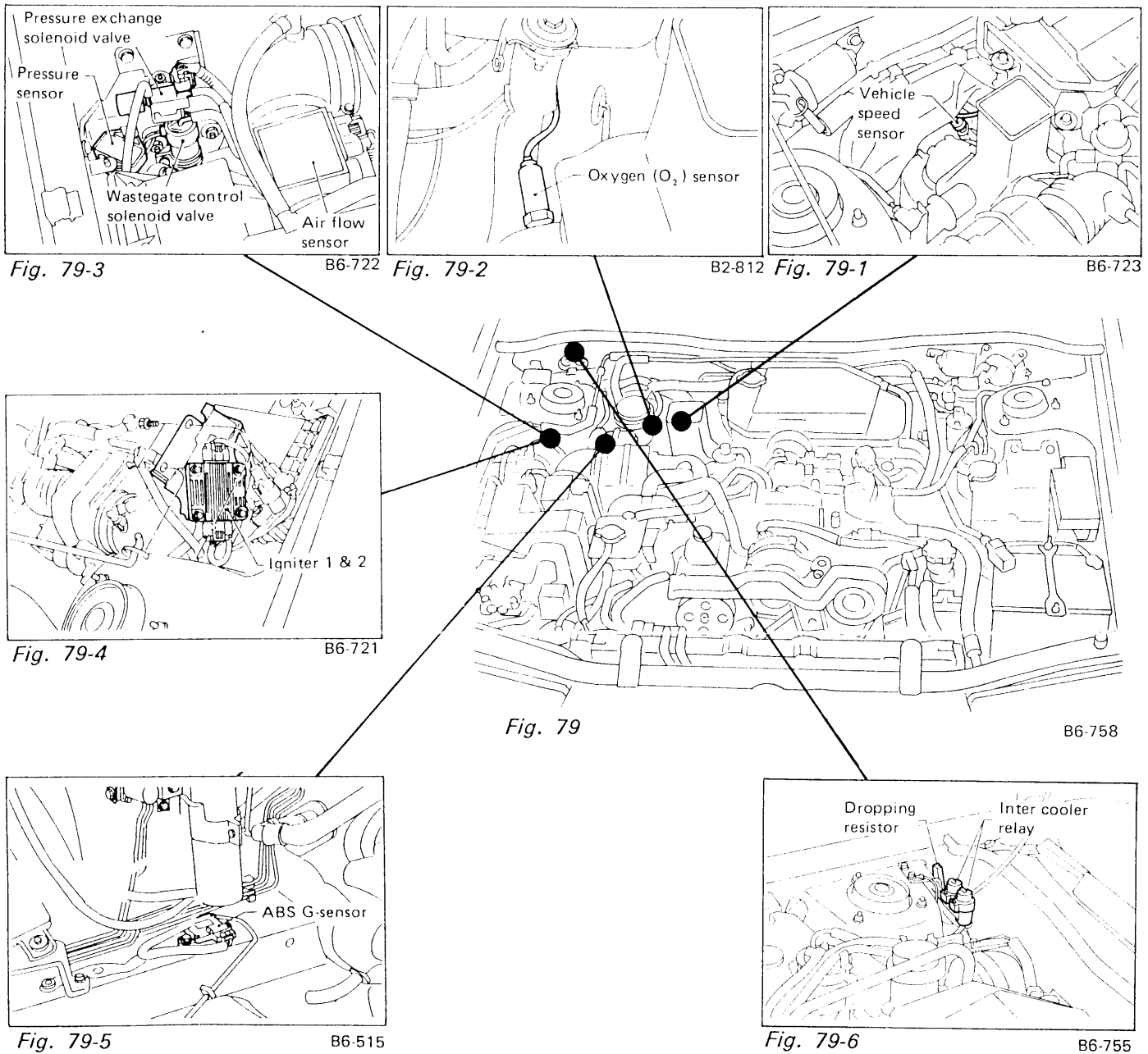


Fig. 78-5

B6-335

ABS G-sensor	Fig. 78-5	Igniter 1 & 2	Fig. 78-4
Vehicle speed sensor	Fig. 78-1	Knock sensor	Fig. 79-4
Pressure sensor	Fig. 78-3	Mode actuator	Fig. 80-3
Blower motor resistor	Fig. 80-2	P/W circuit breaker	Fig. 80-4
By-pass air control valve	Fig. 79-3	O ₂ sensor	Fig. 78-2
Cam angle sensor	Fig. 79-5	Thermometer	Fig. 79-2
CPC solenoid	Fig. 79-1	Throttle sensor	Fig. 79-3
Crank angle sensor	Fig. 79-6	Water temperature sensor	Fig. 79-2
Dropping resistor	Fig. 78-6	Pressure exchange solenoid valve	Fig. 78-3
Fuel gauge unit	Fig. 80-1	Wastegate control solenoid valve	Fig. 78-3

(3) Engine Room (TURBO model)



(4) Engine (TURBO model)

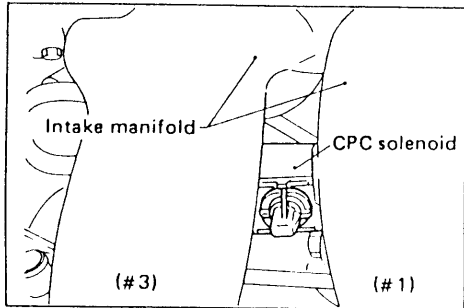


Fig. 80-1

B6-338

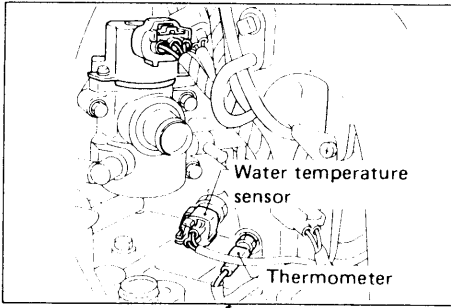


Fig. 80-2

B6-726

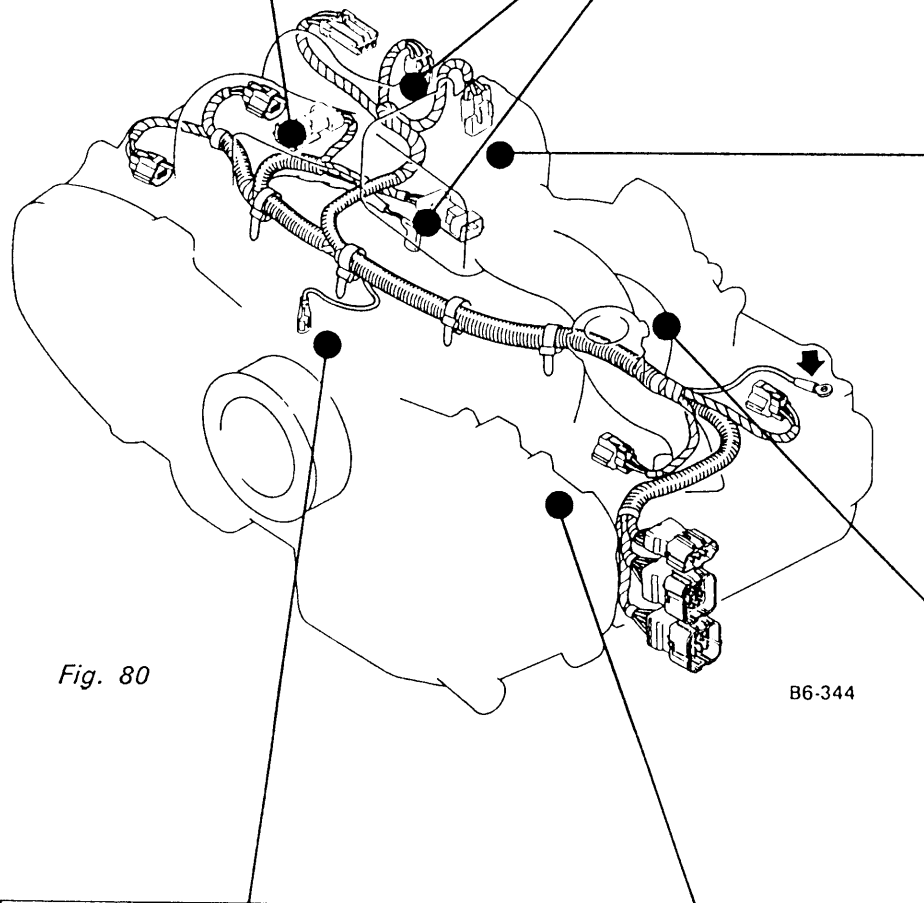


Fig. 80

B6-344

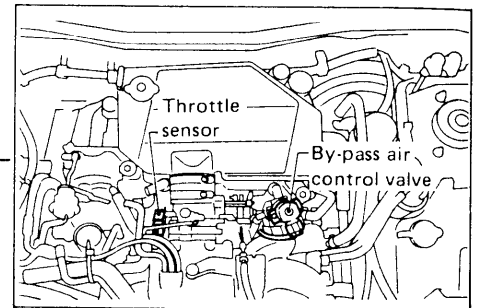


Fig. 80-3

B6-720

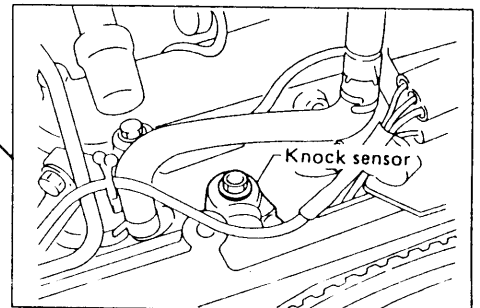


Fig. 80-4

B6-336

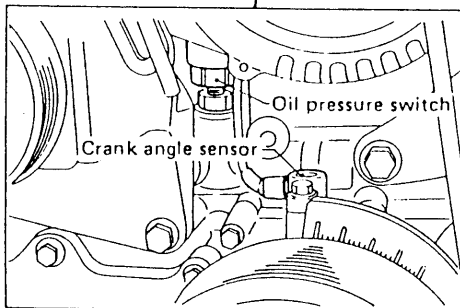


Fig. 80-6

B6-334

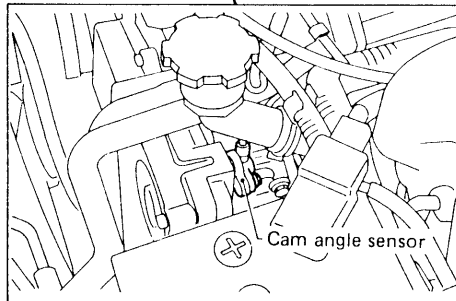
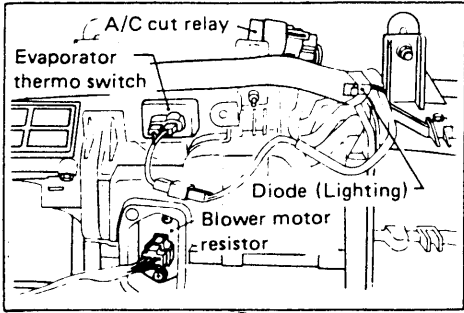


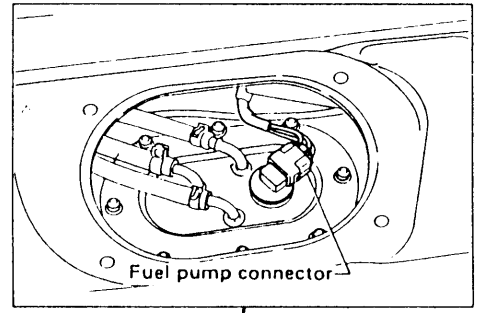
Fig. 80-5

B6-732

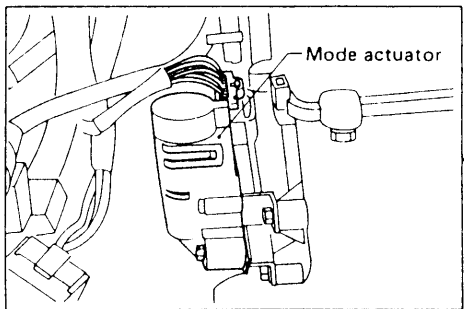
(5) Compartment



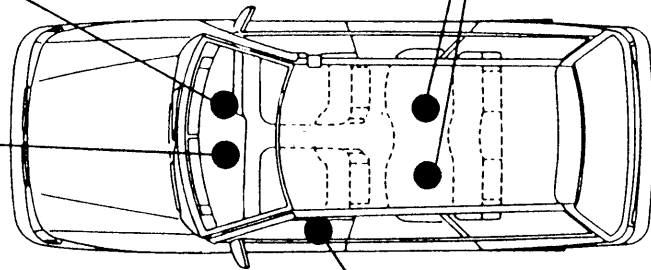
B6-582



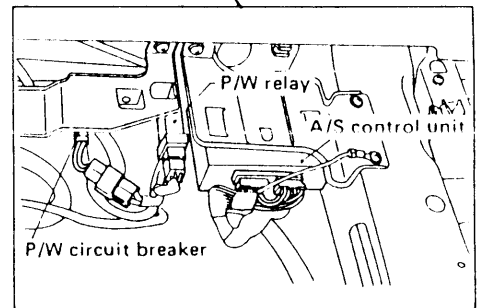
B2-160



B6-300



B6-331B



B6-295

Sec. 5 DIODE•CONDENSER

Diode (Door warning)	Fig. 81-2
Diode (Lighting)	Fig. 81-1
Condenser (Horn)	Fig. 81-3

Condenser (Rear defogger)	Fig. 82-1 Fig. 83-1
---------------------------	------------------------

(1) Instrument Panel

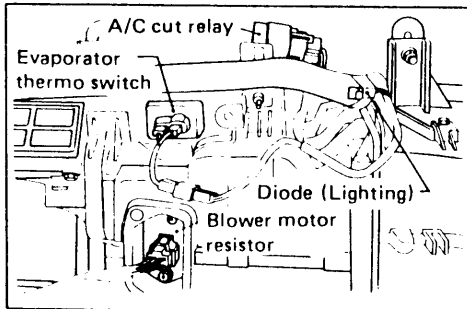


Fig. 82-1

B6-582

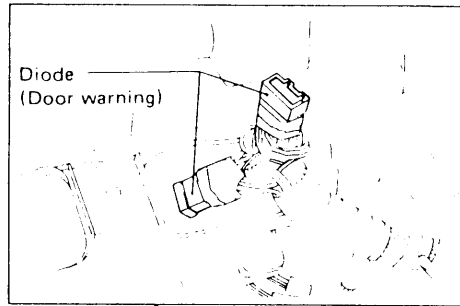


Fig. 82-2

B6-294

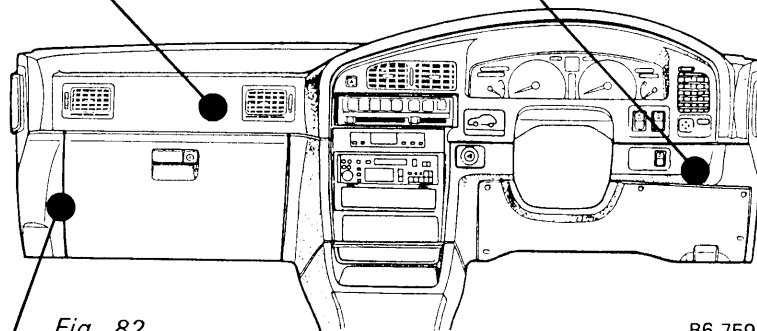


Fig. 82

B6-759

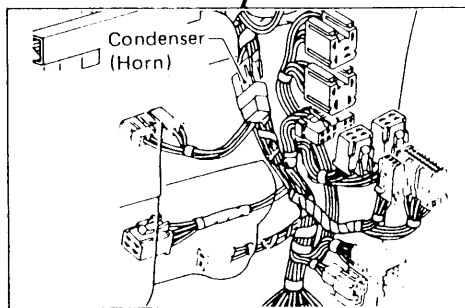


Fig. 82-3

B6-516

(2) Trunk Room

(3) Luggage Room

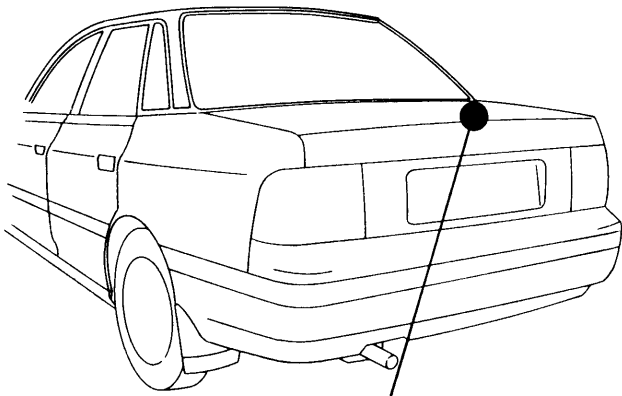


Fig. 83

B6-719

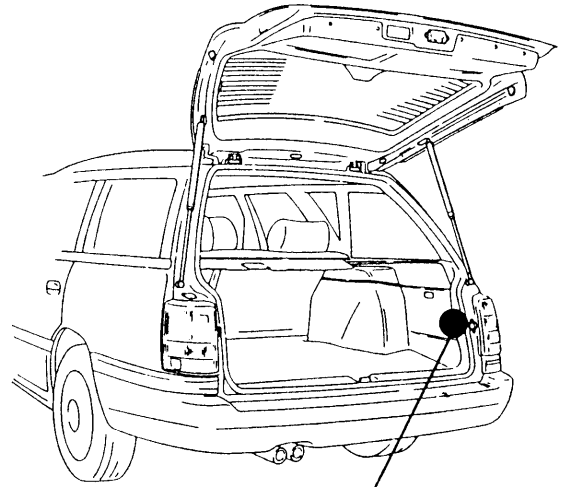


Fig. 84

B6-332

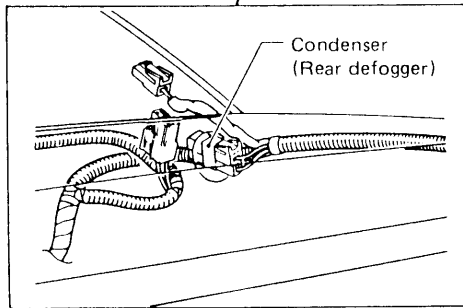


Fig. 83-1

B6-347

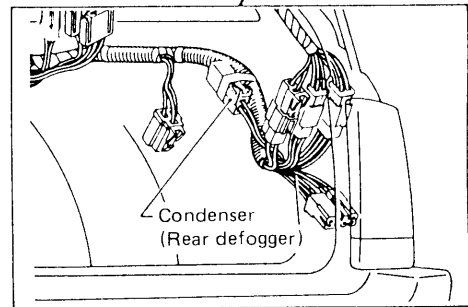


Fig. 84-1

B6-348

Sec. 6 FUSE AND FUSIBLE LINK

(1) Engine Room

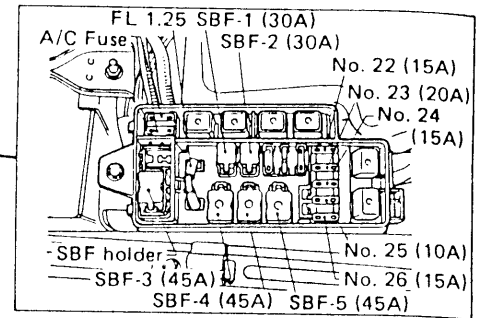
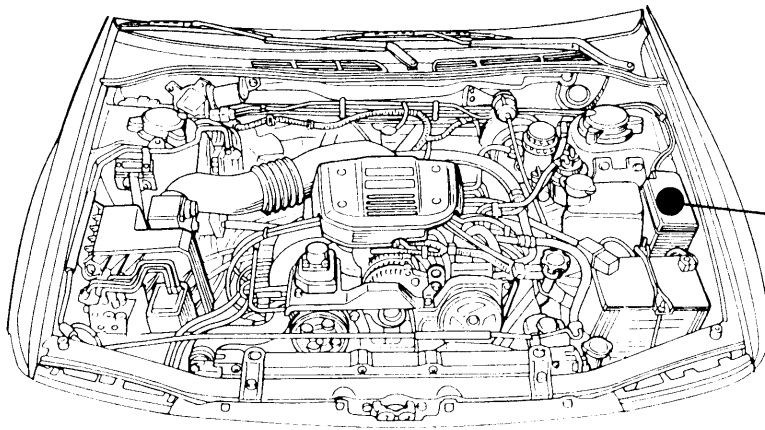


Fig. 85-1

B6-349

Fig. 85

B6-718C

(2) Instrument Panel

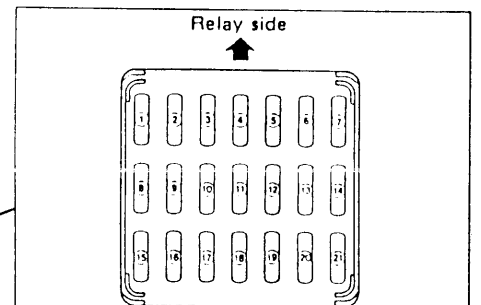
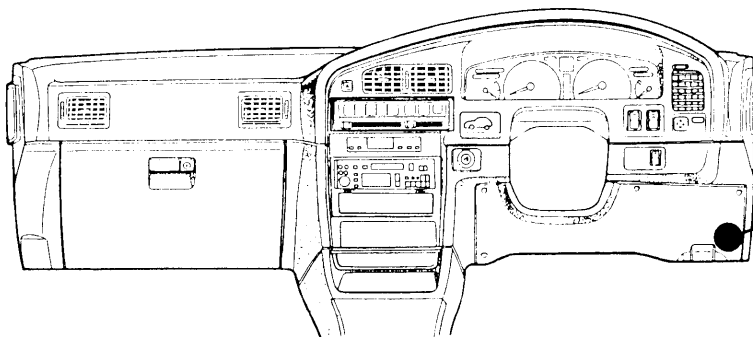


Fig. 86-1

B6-167

Fig. 86

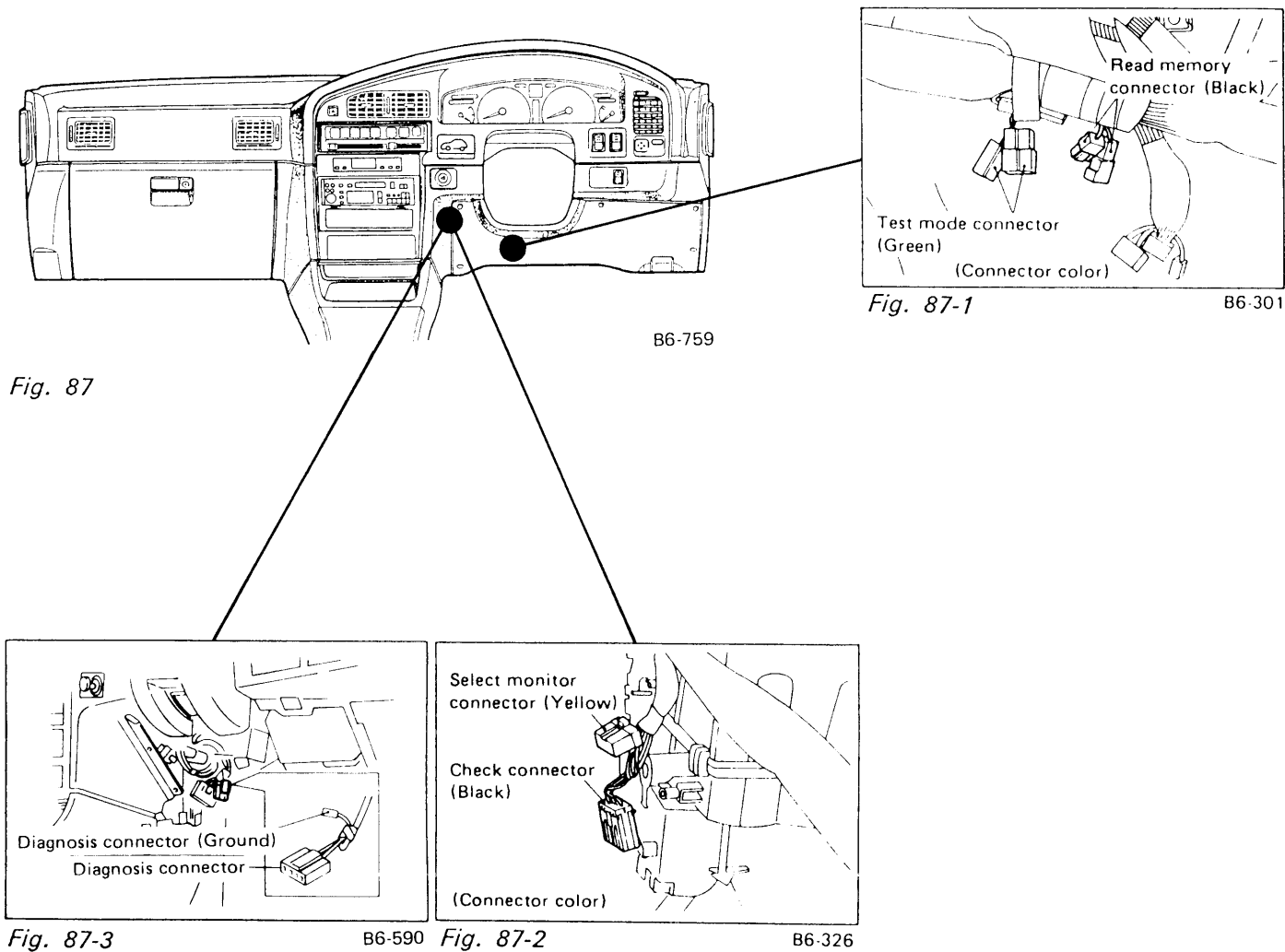
B6-759

Sec. 7 SELECT MONITOR CONNECTOR AND CHECK CONNECTOR

Check connector	Fig. 86-2
Diagnosis connector	Fig. 86-3
Diagnosis connector (Ground)	Fig. 86-3

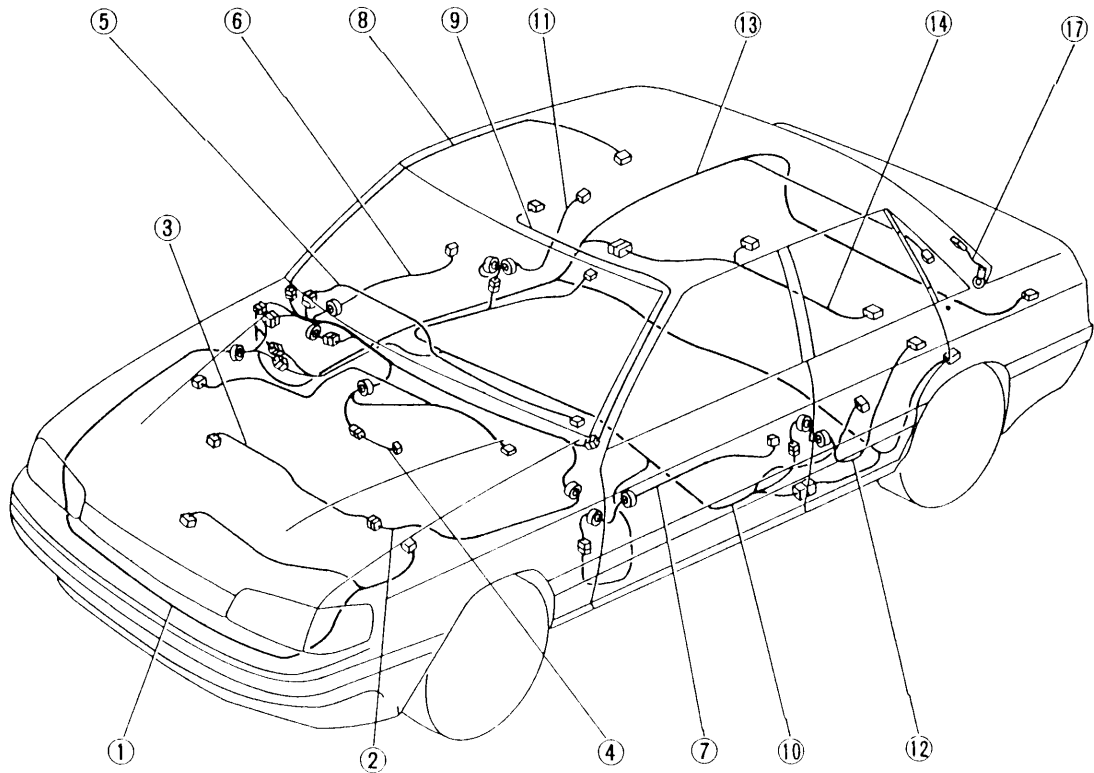
Read memory connector	Fig. 86-1
Select monitor connector	Fig. 86-2
Test mode connector	Fig. 86-1

Instrument Panel

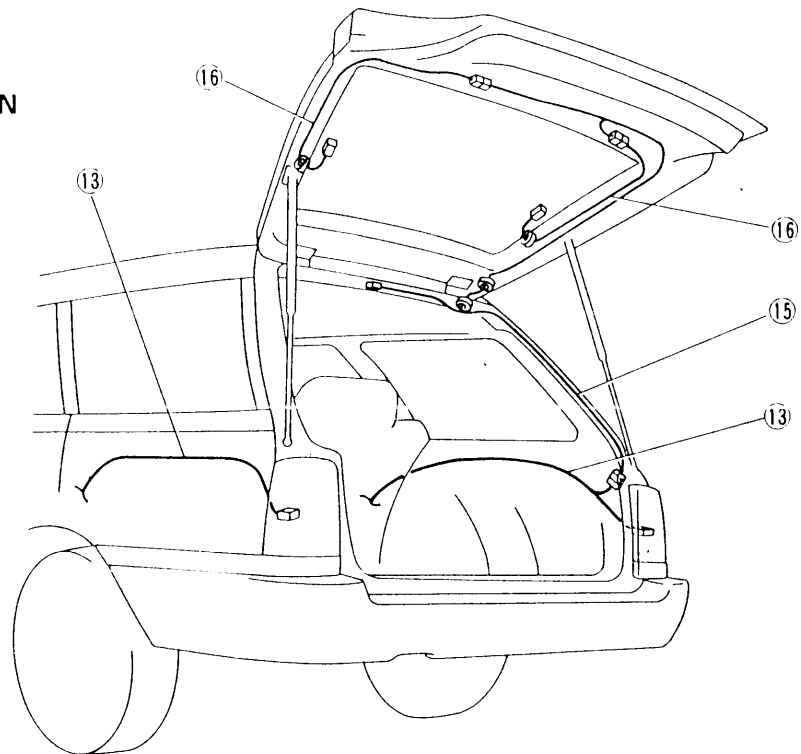


7. Electrical Wiring Harness and Ground Point

SEDAN



WAGON



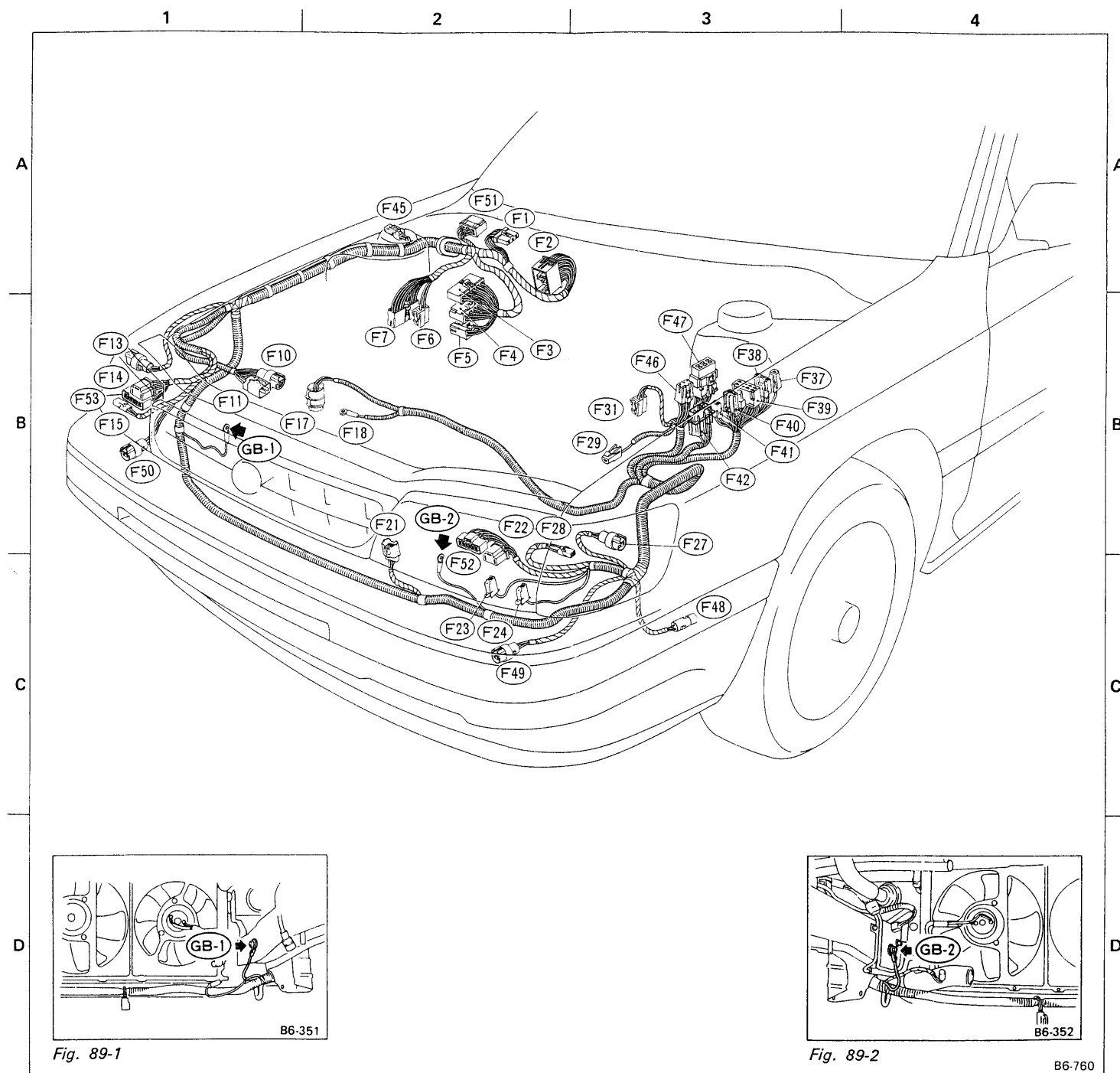
- 1 Front wiring harness
- 2 Bulkhead wiring harness
- 3 Engine wiring harness
- 4 Transmission cord
- 5 Instrument panel wiring harness
- 6 Front door cord RH
- 7 Front door cord LH
- 8 Room light cord
- 9 Sunroof cord or spot light cord
- 10 Power window main harness
- 11 Rear door cord RH
- 12 Rear door cord LH
- 13 Rear wiring harness
- 14 Fuel cord
- 15 Rear gate cord
- 16 Rear defogger cord
- 17 Rear defogger cord (Ground)

Fig. 88

B6-533

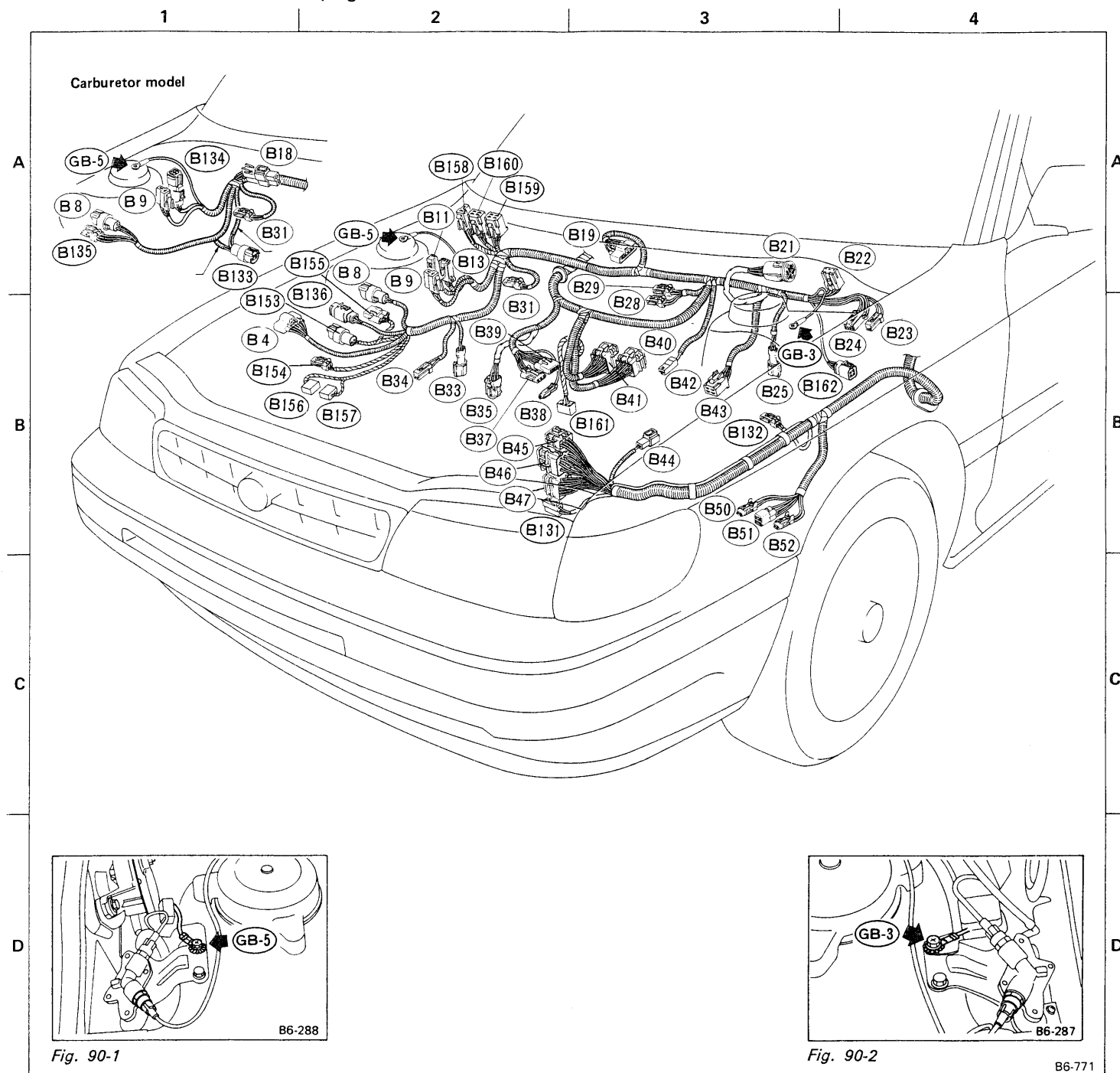
Connector				Connecting to	
No.	Pole	Color	Area	No.	Name
F1	6		A-2	B89	Bulkhead wiring harness
F2	40	White	A-2	B86	Bulkhead wiring harness (SMJ)
F3	10	Gray	A-2		F/B
F4	3	Gray	B-2		
F5	5	Gray	B-2		
F6	2		B-2	P5	Power window main harness
F7	13		B-2	P4	
F10	12	Black	B-1		Hydraulic unit (ABS)
F11	2	Gray	B-1		
F13	2		B-1		Front turn signal light RH
F14	3	Black	B-1		Headlight RH
F15	2	Black	B-1		Front clearance light RH
F17	4	Black	B-2		Alternator
F18	1 x 2		B-2		
F21	3	Black	B-2		Fan motor (Cooling fan)
F22	3	Black	C-2		Headlight LH
F23	1	Black	C-2		Horn
F24	1	Black	C-2		
F27	2		B-3		Front turn signal light LH
F28	2	Black	B-2		Front clearance light LH
F29	1	Brown	B-3	B44	Bulkhead wiring harness
F31	2	Green	B-3		Front washer motor
F37	1		B-3		
F38	2	Black	B-3		M/B
F39	8		B-3		
F40	3		B-3		
F41	2	Black	B-3		
F42	4		B-3		SBF holder
F45	2		A-2		Side turn signal RH
F46	5	Black	B-3		A/C cord (MPFI/SPFI)
F46	2	Black	B-3		A/C cord (CARB)
F47	6	Black	B-3		A/C adapter
F48	2		C-3		Intercooler pump (TURBO model)
F49	2		C-2		Front fog light (LH)
F50	2		B-1		Front fog light (RH)
F51	6		A-2	i56	Instrument panel wiring harness
F52	6	Gray	B-2		Headlight leveler (LH)
F53	6	Gray	B-1		Headlight leveler (RH)

1. FRONT WIRING HARNESS AND GROUND POINT



Connector				Connecting to	
No.	Pole	Color	Area	No.	Name
B4	6		B-1		Air flow meter
B8	2	Black	B-2		Dropping resistor (4AT)
B9	2	Black	A-2		FWD switch (4AT)
B11	2	Black	A-2		A/S front solenoid
B13	4	Black	A-2		A/S front sensor
B18	2	Black	A-1		Noise condenser (CARB & SPFI)
	6		A-3		Igniter (MPFI)
B19	4	Gray	A-3		Ignition coil (SPFI)
	2	Black	A-3		Ignition coil (CARB)
B21	5		A-3		Wiper motor
B22	5	Black	A-3		A/S compressor relay
B23	2	Gray	B-4		A/S front solenoid
B24	4	Gray	B-4		A/S front sensor
B25	2	Gray	B-3		ABS front sensor LH
B28	2	Brown	B-3		4WD solenoid (Part time 4WD)
B29	2	Blue	B-3		FWD solenoid (Part time 4WD)
B31	2	Gray	A-2		Brake fluid level sensor
B33	2	Gray	B-2		ABS front sensor RH
B34	2	Black	B-2		ABS G-sensor (MT)
B35	4	Gray	B-2		O ₂ sensor (ADR)
B37	3	Gray	B-2		Crank angle sensor
B38	1	Gray	B-2		Knock sensor
B39	3	Gray	B-2		Cam angle sensor
	14	Gray	B-3	E28	Transmission (3AT)
	12	Gray	B-3	E25	Transmission (4AT)
	8	Gray	B-3	E21	
B40	6	Gray	B-3	E21	Transmission (MT)
	4	Gray	B-3	E21	
	2	Gray	B-3	E21	
B41	16	Gray	B-3	E26	Transmission (4AT)
B42	1		B-3		Starter (Magnet)
B43	4		B-3		Cruise control pump
B44	1		B-3		Front wiring harness
	8			F29	
B45	5	Gray	B-2	E3	Engine wiring harness
B46	14	Gray	B-2	E2	
B47	16	Gray	B-2	E1	Engine wiring harness
B50	2	Gray	B-3		A/S charge solenoid
B51	4	Gray	B-3		A/S compressor
B52	2	Brown	B-2		A/S pressure switch
B131	2	Blue	B-2		Headlight washer motor (Europe)
B132	2		B-3		Side turn signal LH
B133	2		A-1		Distributor (CARB)
B134	2		A-1		Dropping resistor (CARB)
B135	3	Gray	A-1		Vacuum sensor (CARB)
B136	4		B-2		Dropping resistor (MPFI)
B153	2	Black	B-2		Wastegate control solenoid valve
B154	2	Brown	B-1		Pressure exchange solenoid valve
B155	3	Gray	B-2		Pressure sensor
B156	5	Gray	B-1		Ignitor 1
B157	4	Gray	B-2		Ignitor 2
B158	2		A-2		Dropping resistor
B159	4	Blue	A-2		Intercooler relay 1
B160	4	Green	A-2		Intercooler relay 2
B161	3		B-2		Vehicle speed sensor
B162	4		B-4		Dim dip resistor

2. BULKHEAD WIRING HARNESS (Engine side)



(MPFI NA MODEL)

Connector				Connecting to	
No.	Pole	Color	Area	No.	Name
E1	16	Gray	B-3	B47	Bulkhead wiring harness
E2	12	Gray	B-3	B46	
E6	2	Gray	B-3		Injector #2
E7	2	Gray	B-3		Injector #4
E8	3	Gray	A-2		By-pass air control valve
E9	4	Gray	A-3		Throttle sensor
E10	2	Brown	A-2		Water temperature sensor
E11	1	Black	A-2		Thermometer
E12	1	Black	A-2		Oil pressure switch
E15	2	Gray	A-2		Injector #1
E16	2	Gray	A-2		Injector #3
E17	2	Blue	A-2		CPC solenoid
E31	2	Gray	A-2		Ignition coil

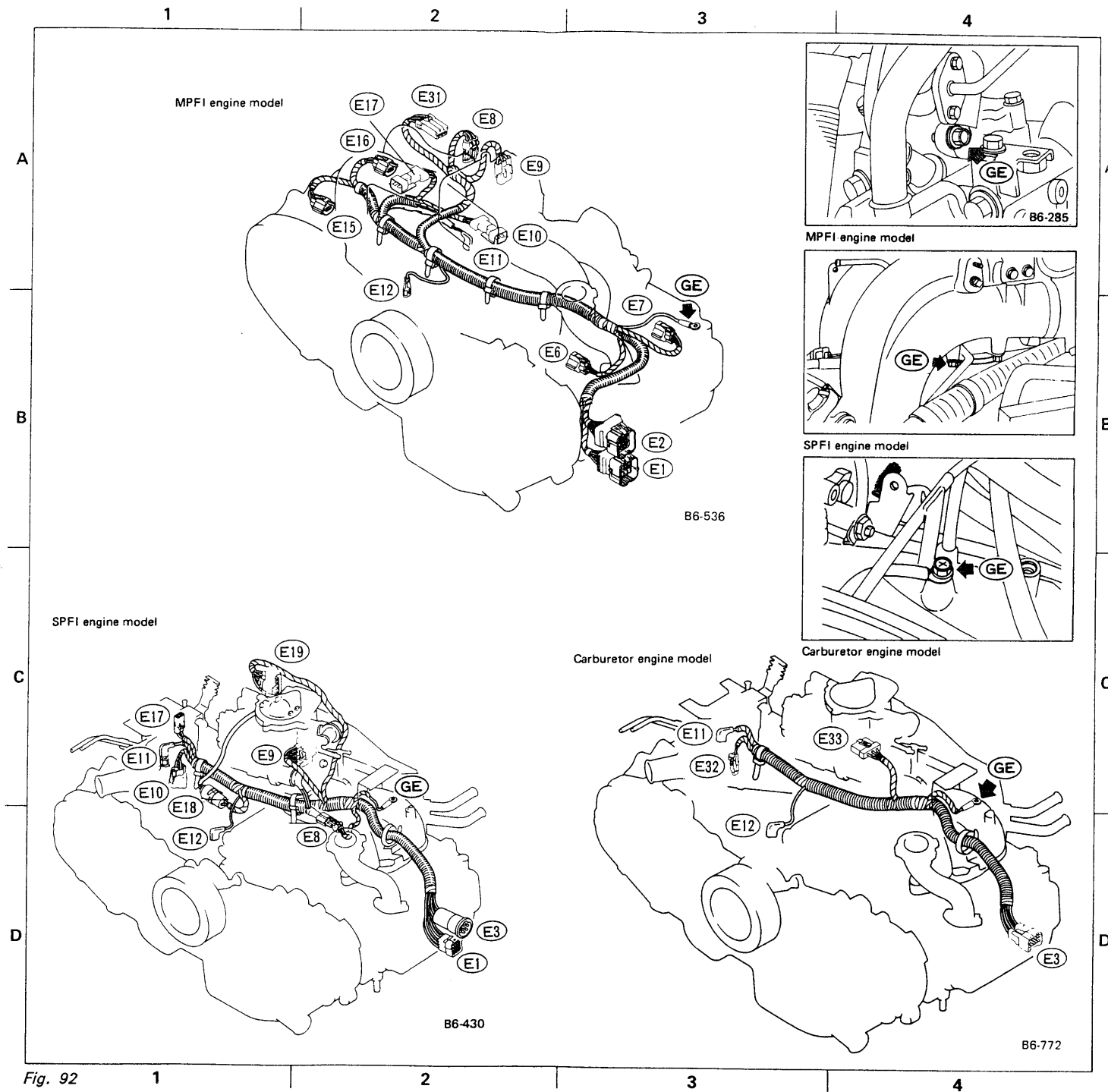
(SPFI MODEL)

Connector				Connecting to	
No.	Pole	Color	Area	No.	Name
E1	16	Gray	D-2	B47	Bulkhead wiring harness
E3	5	Gray	D-2	B45	
E8	2	Gray	D-2		By-pass air control valve
E9	4	Gray	C-1		Throttle sensor
E10	2	Brown	C-1		Water temperature sensor
E11	1	Black	C-1		Thermometer
E12	1	Black	D-1		Oil pressure switch
E17	2	Blue	C-1		CPC solenoid valve
E18	2	Black	C-1		Fuel injector
E19	5	Gray	C-1		Air flow sensor

(CARBURETOR MODEL)

Connector				Connecting to	
No.	Pole	Color	Area	No.	Name
E3	8	Gray	D-3	B45	Bulkhead wiring harness
E11	1	Black	C-2		
E12	1	Black	C-2		Thermometer
E32	1	Gray	C-2		Oil pressure switch
E33	3	Gray	C-2		Fan switch
					Idle switch

3. ENGINE WIRING HARNESS AND GROUND POINT



Connector				Connecting to	
No.	Pole	Color	Area	No.	Name
E21	8	Gray	C-1	B40	Bulkhead wiring harness (MT)
	6	Gray	C-1	B40	
	4	Gray	C-1	B40	
	2	Gray	C-1	B40	
E22	2		D-2		Back-up light switch (MT)
E23	2	Black	D-2		Neutral switch (MT)
E24	2		D-2		4WD indicator light switch (Selective 4WD)
E25	12	Gray	A-1	B40	Bulkhead wiring harness (AT)
E26	16	Gray	A-2	B41	
E27	2	Black	D-2		4WD-Lo indicator light switch (Dual-range)
E28	14	Gray	B-3	B40	Bulkhead wiring harness (3AT)
E29	2		B-3		Kick-down solenoid (3AT)

4. TRANSMISSION CORD

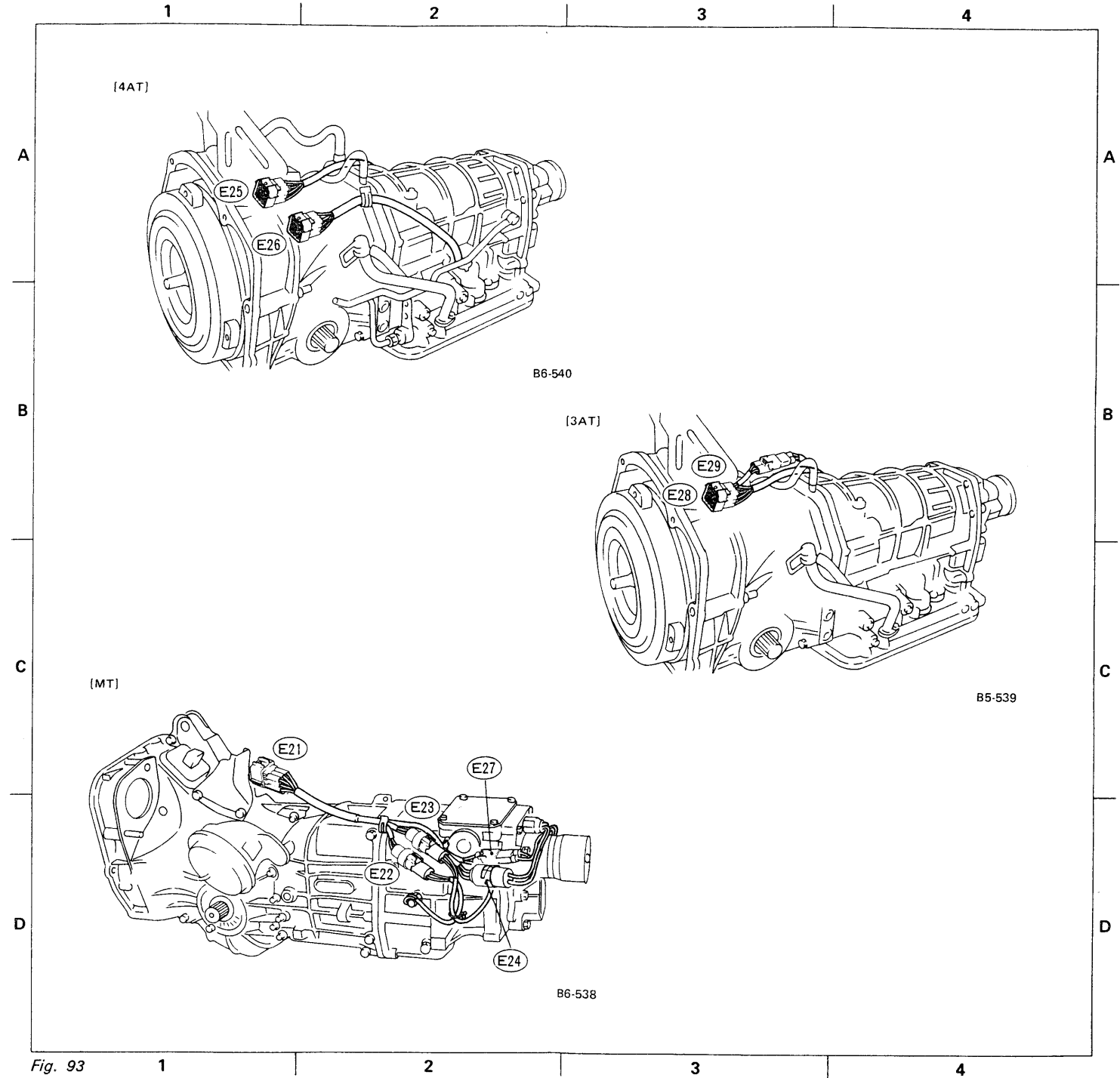
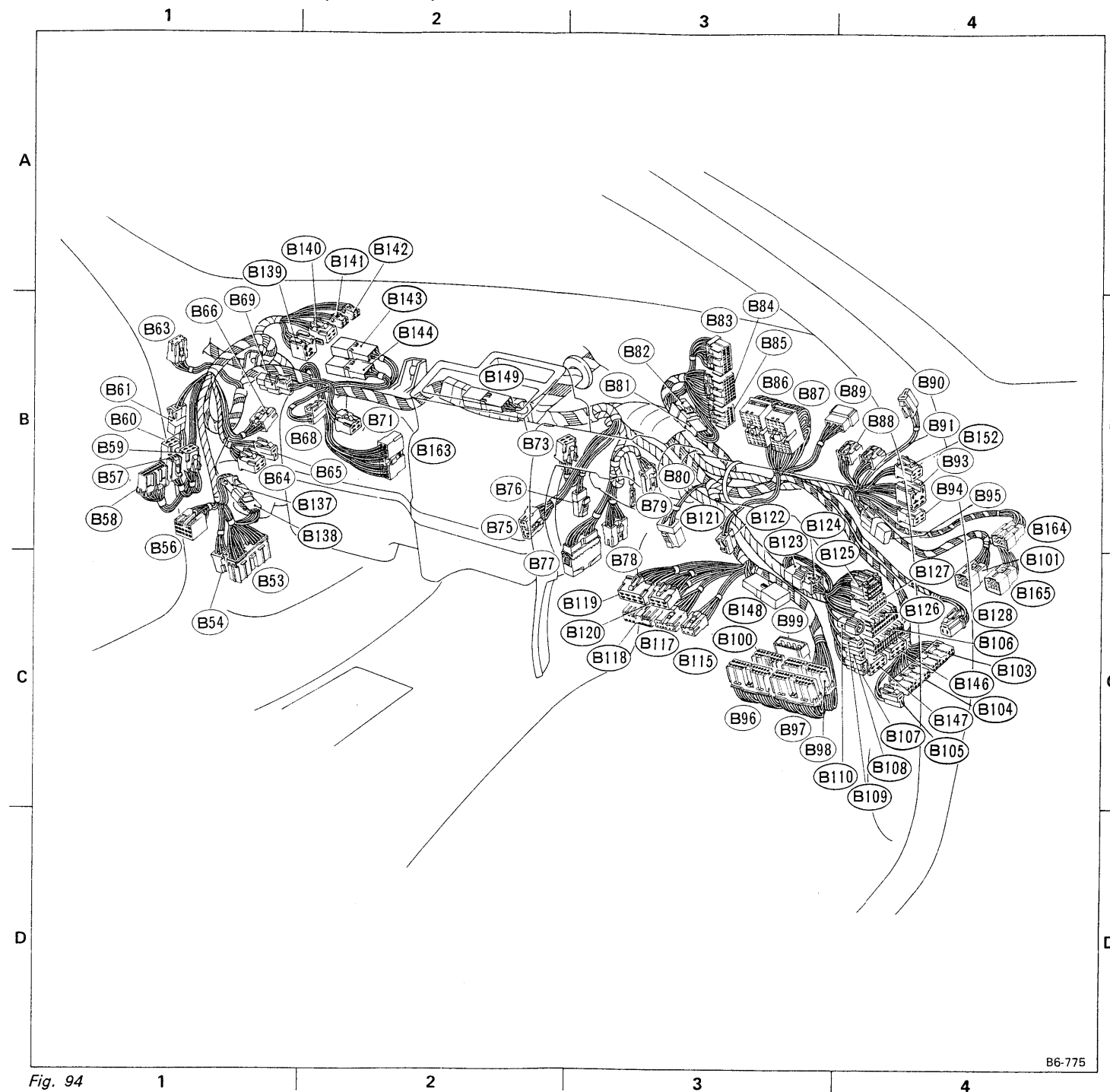


Fig. 93

Connector				Connecting to	
No.	Pole	Color	Area	No.	Name
B53	22	Black	B-1	P26	Power window main harness
B54	8	Black	B-1	P25	Power window main harness
B56	4		C-1	P29	Front door cord LH
B57	13		B-1		Cruise control unit
B58	4		B-1		Main relay (Cruise control)
B59	20		B-1		Inhibitor relay (AT-cruise control)
B60	4	Black	B-1		Diode (AT-cruise control)
B61	2	White	B-1	R7	Sunroof cord
B63	4	Black	B-1		Blower motor resistor
B64	5	Black	B-1		Blower motor
B65	2	Black	B-1		FRESH/RECIRC actuator
B66	4	Black	B-1		Evaporator thermostat
B68	2	Black	B-2		Diode (Lighting)
B69	2	Black	B-1		A/C cut relay
B71	4	Blue	B-2	i12	Instrument panel wiring harness
B73	4	Blue	B-2		Mode actuator
B75	7		B-2		Clutch switch (MT-cruise control)
B76	2	Blue	B-3		Check connector
B77	22	Black	B-3		Select monitor connector
B78	9	Yellow	B-3		Diagnosis terminal (Ground)
B79	1		B-3		Diagnosis connector
B80	4	Black	B-3	B82	Shield joint connector (4AT)
B81	4	Black	B-3	B81	AT control unit
B82	4	Black	B-3		Front wiring harness (SMJ)
B83	16	Black	B-3	F2	Rear wiring harness (SMJ)
B84	20	Black	B-3	R2	Blower relay
B85	12	Black	B-3	F1	Front wiring harness
B86	40	White	B-3	R1	Room light cord
B87	40	Gray	B-3		Front fog light relay
B88	4		B-4		Ignition relay
B89	6		B-4		Fuel pump relay
B90	2	Green	B-4		Diode (Engine)
B91	4	Blue	B-4	i35	
B93	6	Brown	B-4	i36	
B94	4	Green	B-4	i33	Instrument panel wiring harness
B95	2	Black	B-4	i32	
B96	22	Black	C-3	i31	
B97	22		C-3	P1	Front door cord RH
B98	22	Blue	C-3		
B99	8		C-3		
B100	14	Black	C-3		
B101	13		C-4		
B103	11	Gray	C-4		
B104	12	Gray	C-4		
B105	2	Brown	C-4		
B106	26	Yellow	C-4		
B107	2	Green	C-4	B108	MPFI/SPFI control unit
B108	2	Green	C-4	B107	Test mode connector
B109	1	Black	C-4	B110	Read memory connector
B110	1	Black	C-4	B109	Cruise control sub-switch
B115	5	Black	C-3		

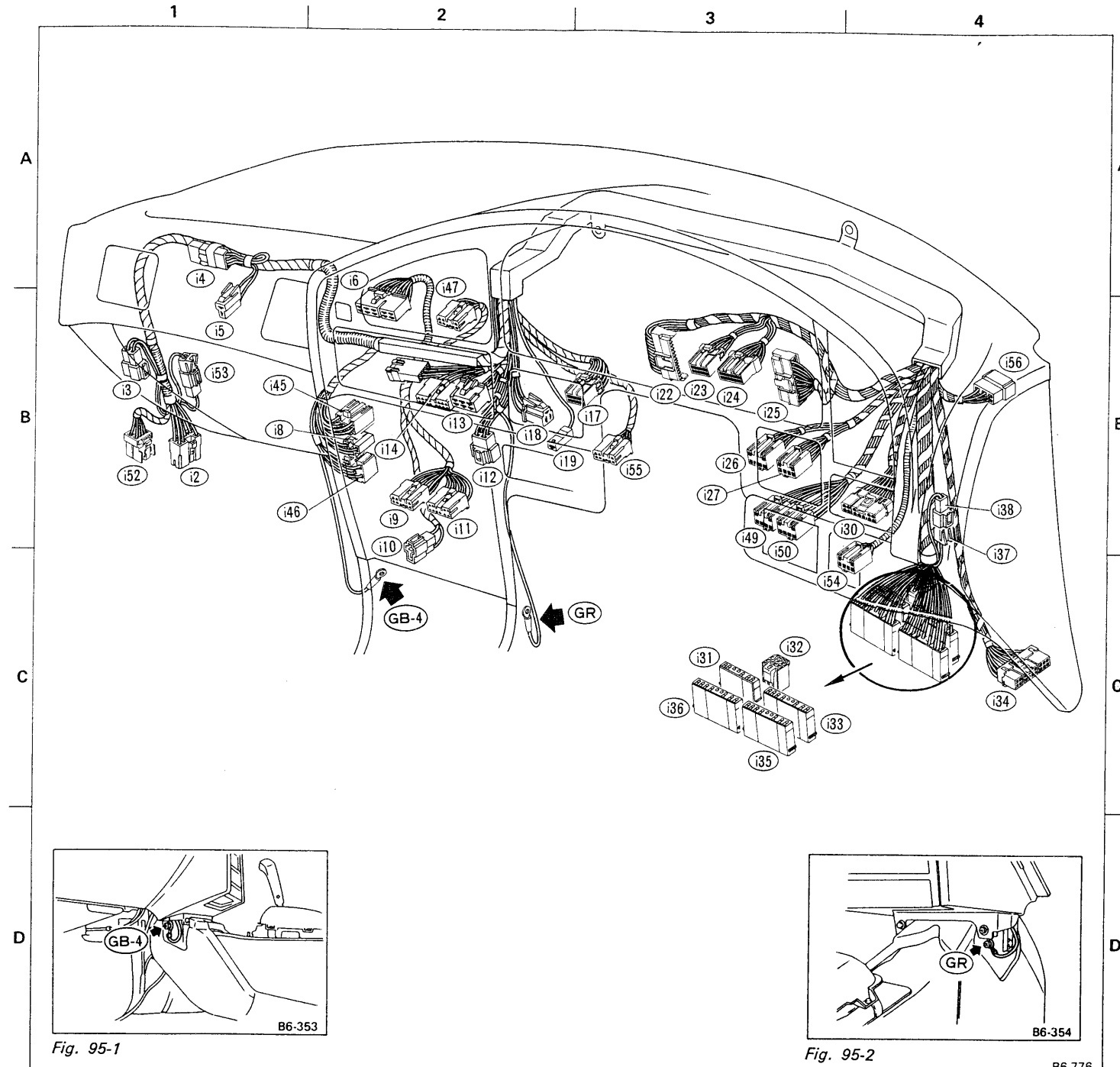
Connector				Connecting to	
No.	Pole	Color	Area	No.	Name
B117	9	Black	C-3		Combination switch (Turn signal)
B118	11	Black	C-3		Combination switch (Wiper)
B119	8	Black	C-3		Combination switch (Lighting)
B120	6	Black	C-3		Ignition switch
B121	4	Black	B-3		Stop and Brake switch (with cruise control)
B122	2	Black	B-3		Stop light switch (without cruise control)
B123	2	Black	C-3	B124	Kick-down switch (AT)
B124	2	Black	C-3	B123	Shield joint connector
B125	12	Yellow	C-4		MPFI control unit
B126	22	Yellow	C-4		MPFI/SPFI control unit
B127	16	Yellow	C-4		MPFI/SPFI control unit
B128	3	Black	C-4		Horn relay
B137	2	Black	B-1	B138	Shield joint connector (ABS)
B138	2	Black	B-1	B137	
B139	5	Black	B-2		Dim-dip relay
B140	4		B-2		Dim-dip control relay
B141	4		B-2		Dim-dip main beam cancel relay
B142	4		B-2		Dim-dip cancel relay
B143	3		B-2		Diode (Dim-dip)
B144	3		B-2		Diode (Dim-dip)
B146	6		C-4		Revolution sensor (CARB)
B147	6	Black	C-4		Headlight washer unit (Europe)
B148	2	Black	C-3		Diode (Rear fog lamp)
B149	3	Black	B-2		Diode (4WD-solenoid)
B152	4		B-4		Load relay (SPFI)
B153	17		B-2		Keyless entry unit
B164	8		B-4	P54	Front door cord RH (with keyless entry)
B165	13		B-4	P55	Front door cord RH

5. BULKHEAD WIRING HARNESS (Interior side)



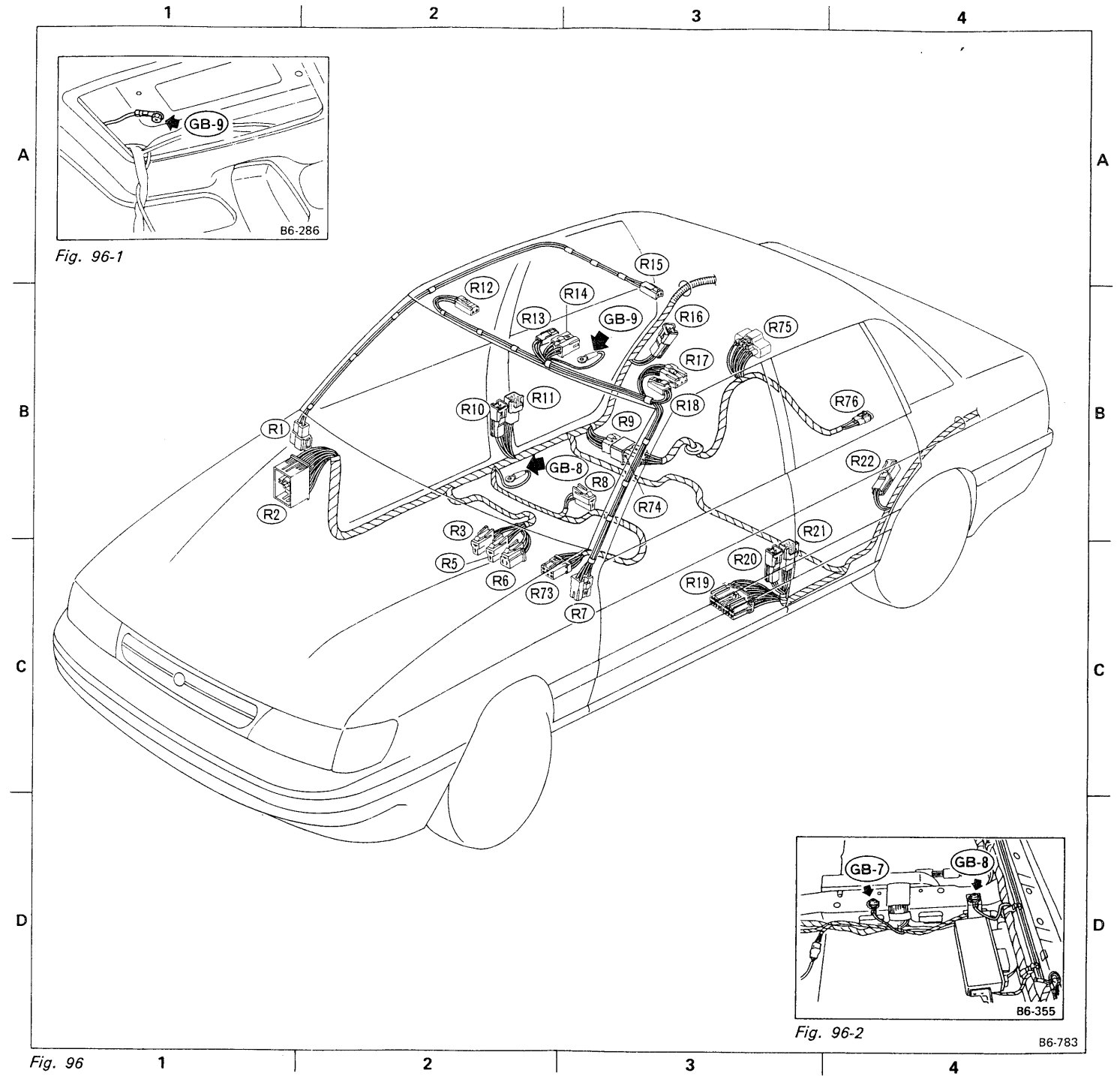
Connector				Connecting to	
No.	Pole	Color	Area	No.	Name
i2	7		B-1	P27	Power window main harness
i3	2		B-1		Glove box light switch
i4	2	Black	A-1		Diode (A/C) (GX • LX • GL)
i5	2	Brown	B-1		Glove box light
i6	10		B-2		Hazard switch
i8	3	Black	B-2		Turn signal & Hazard unit
i9	7		B-2		Radio
i10	2	Black	B-2		Ash tray illumination light
i11	9		B-2		Radio
i12	4	Blue	B-2	B73	Bulkhead wiring harness (A/C)
i13	6	Black	B-2		Fan switch
i14	13	Black	B-2		Mode control panel
i17	12		B-3		Height control switch
i18	3		B-2		Cigarette lighter illumination light
i19	1		B-2		Cigarette lighter
i22	12		B-3		Combination meter
i23	12		B-3		
i24	16		B-3		
i25	12		B-3		
i26	6	Brown	B-3		Cruise control main switch
i27	6		B-3		Rear defogger switch
i30	12	Black	B-4		Remote control rearview mirror switch
i31	14	Black	C-3	B100	Bulkhead wiring harness (AT)
i32	8		C-3	B99	Bulkhead wiring harness
i33	22	Blue	C-3	B98	
i34	15	Gray	C-4		F/B
i35	22	Black	C-3	B96	Bulkhead wiring harness
i36	22		C-3	B97	
i37	1		B-4	i38	Illumination control short connector (without illumination control)
i38	1		B-4	i37	
i42	2		B-2		Diode (A/C) (DL)
i45	6	Black	B-2		Illumination control unit
i46	5	Black	B-2		Rear fog light relay
i47	7		B-2		Clock & Auto antenna switch
i49	6	Black	B-3		Rear fog light switch
i50	6	Black/Yellow	B-3		Headlight washer switch (Europe)/Front fog light switch (ADR)
i52	8	Black			Delay amp. (Fuel gauge)
i53	1 × 2				Delay amp. cut connector
i54	6	Yellow	C-4		Front fog light switch (Europe)
i55	7		B-3		Headlight leveling switch
i56	6		B-4	F51	Front wiring harness

6. INSTRUMENT PANEL WIRING HARNESS



Connector				Connecting to	
No.	Pole	Color	Area	No.	Name
R1	2	Green	B-2	B90	Bulkhead wiring harness
R2	40	Gray	B-2	B87	Bulkhead wiring harness (SMJ)
R3	2	Blue	B-2		Select lever illumination light (AT)
R5	2	Green	C-2		AT manual switch (4AT)
R6	3	Green	C-2		4WD select switch (MT)
R7	5	Black	C-3	B63	Bulkhead wiring harness
R8	2		B-3		Parking brake switch
R9	5		B-3	R74	Fuel cord ↔ Rear wiring harness
R10	2		B-2		Front door switch RH
R11	6		B-2	P16	Rear door cord RH
R12	2		B-2		Vanity mirror illumination light RH (ADR. GX)
R13	2		B-2		Spot light
R14	5	Black	B-3		Sunroof switch
R15	2		A-3		Room light
R16	2		B-3		Rear door switch RH
R17	5		B-3		Sunroof control unit
R18	2		B-3		Vanity mirror illumination light LH (ADR. GX)
R19	14	Black	C-3	P41	Power window main harness
R20	2		C-3		Front door switch LH
R21	6		C-3	P43	Rear door cord LH
R22	2		B-4		Rear door switch LH
R73	6		C-3		AT economy switch (4AT)
R74	5		B-3	R9	Rear wiring harness
R75	6		B-3		Fuel gauge unit and Fuel pump
R76	2		B-4		Fuel gauge sub unit (4WD)

7. REAR WIRING HARNESS



Connector				Connecting to	
No.	Pole	Color	Area	No.	Name
P1	13		B-1	B101	Bulkhead wiring harness
P4	13		C-1	F7	Front wiring harness
P5	2		C-2	F6	Front door cord RH
P6	9		C-2	P7	Power window main harness
P7	9		C-2	P6	Front speaker RH
P8	2		B-2		Remote control rearview mirror RH
P9	6		B-2		Power window main switch
P10	10		B-2		Front power window motor RH
P11	2	Green	B-2		Front step light RH (ADR)
P12	2	Pink	B-2		Front door lock actuator RH
P15	4		B-2		Rear wiring harness
P16	6		B-2	R11	Rear door cord RH
P17	3		B-2	P18	Power window main harness
P18	3		B-2	P17	Rear power window motor RH
P19	2	Green	B-2		Rear power window sub-switch RH
P20	5		B-3		Rear door lock actuator RH
P21	4		B-3		Rear step light RH (ADR)
P22	2	Pink	B-3		Rear ABS sensor RH
P23	2	Gray	B-3		ABS control unit
P24	35	Blue	B-2		
P25	4		C-2	B54	Bulkhead wiring harness
P26	22	Black	C-2	B53	Bulkhead wiring harness
	8	Black	C-2		
P27	7		C-2	i2	Instrument wiring harness
P29	13		C-2	B56	Bulkhead wiring harness
P30	3		C-3	P31	Power window main harness
P31	3		C-3	P30	Front door cord LH
P32	6		C-3		Remote control rearview mirror LH
P33	5		C-3		Front power window sub-switch LH
P34	2	Pink	C-3		Front step light LH (ADR)
P35	2		C-3		Front speaker LH
P36	2	Green	C-3		Front power window motor LH
P37	16		C-3		A/S control unit
P38	20		C-3		Power window relay
P39	4		C-3		Power window circuit breaker
P40	2		C-3		Rear wiring harness
P41	20	Black	C-3	R19	Rear door cord LH
P42	3		C-3	P45	Rear wiring harness
P43	6		C-3	R21	Front door lock actuator LH
P44	4		C-3		Power window main harness
P45	3		C-3	P42	Rear power window motor LH
P46	2	Green	B-4		Rear power window sub-switch LH
P47	5		B-4		Rear step light LH (ADR)
P48	2	Pink	B-4		Rear ABS sensor LH
P49	2	Gray	B-4		Rear door lock actuator LH
P50	4		B-4		Keyless entry sensor
P51	6	Gray	B-2		Front door lock switch RH
P52	2	Gray	B-2		
P53	8		C-1	B164	Bulkhead wiring harness
P54	13		C-1	B165	Bulkhead wiring harness

8. POWER WINDOW MAIN HARNESS

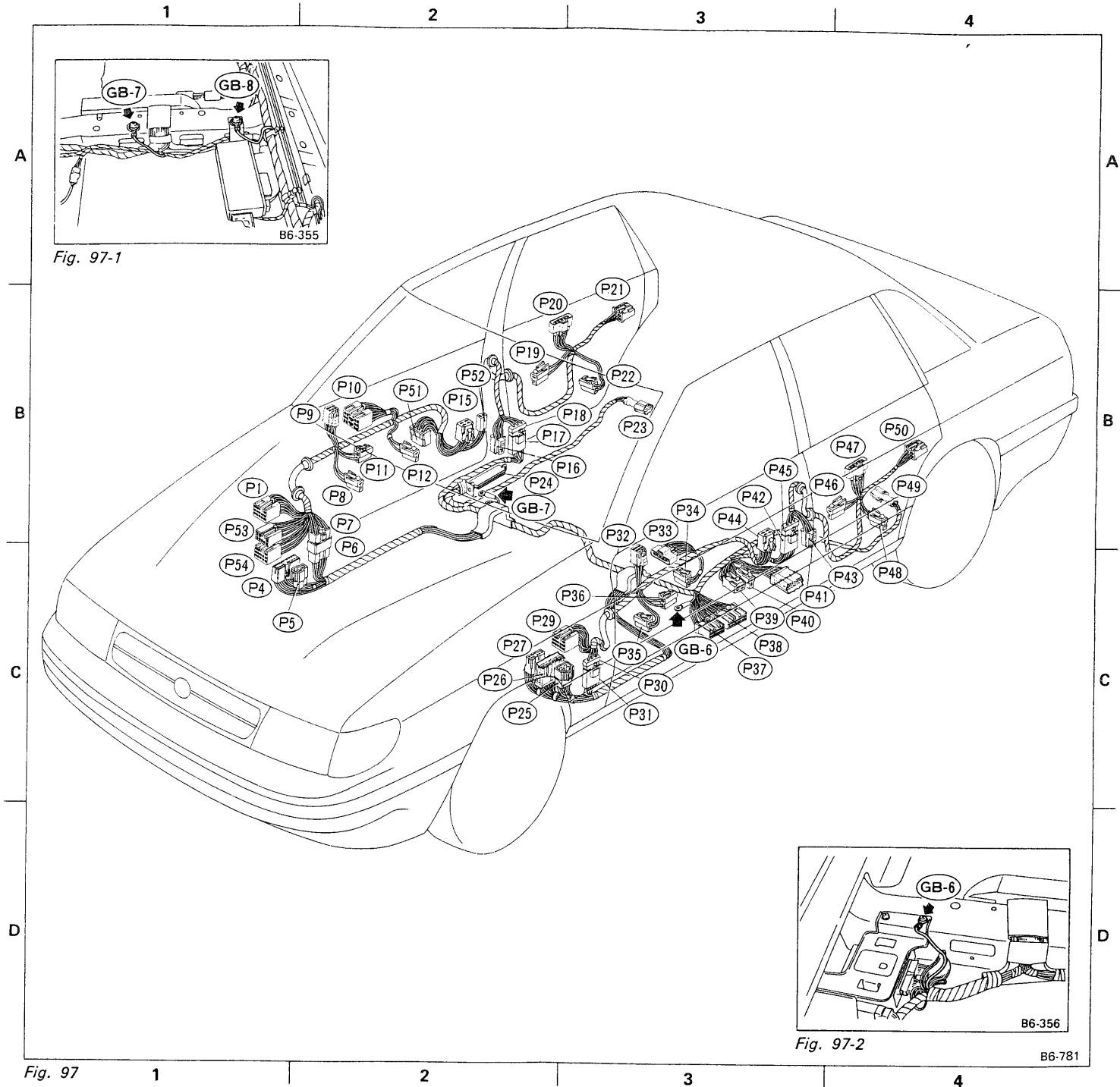
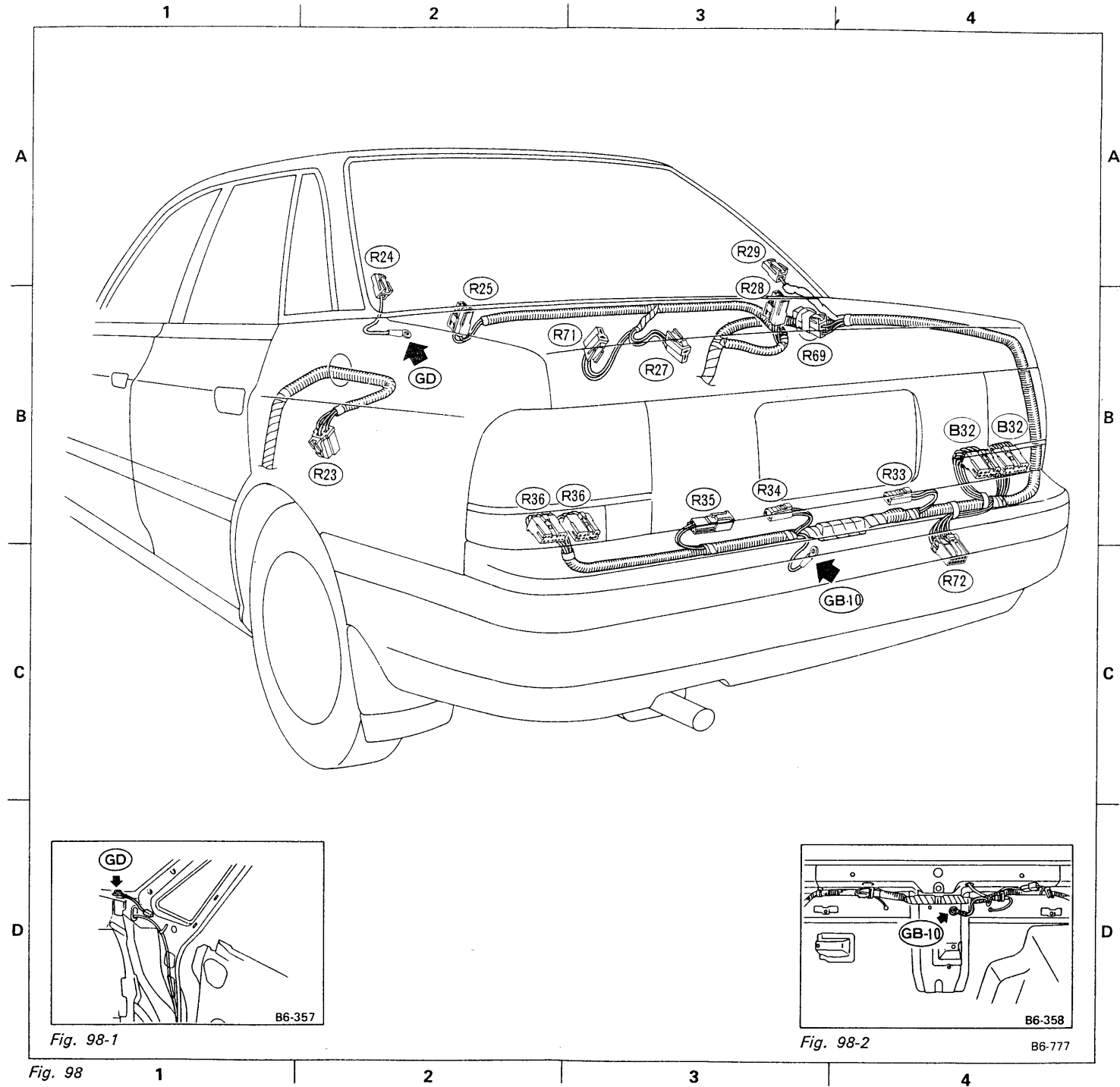


Fig. 97 1 2 3 4
Fig. 97-1 B6-355
Fig. 97-2 B6-356
B6-781

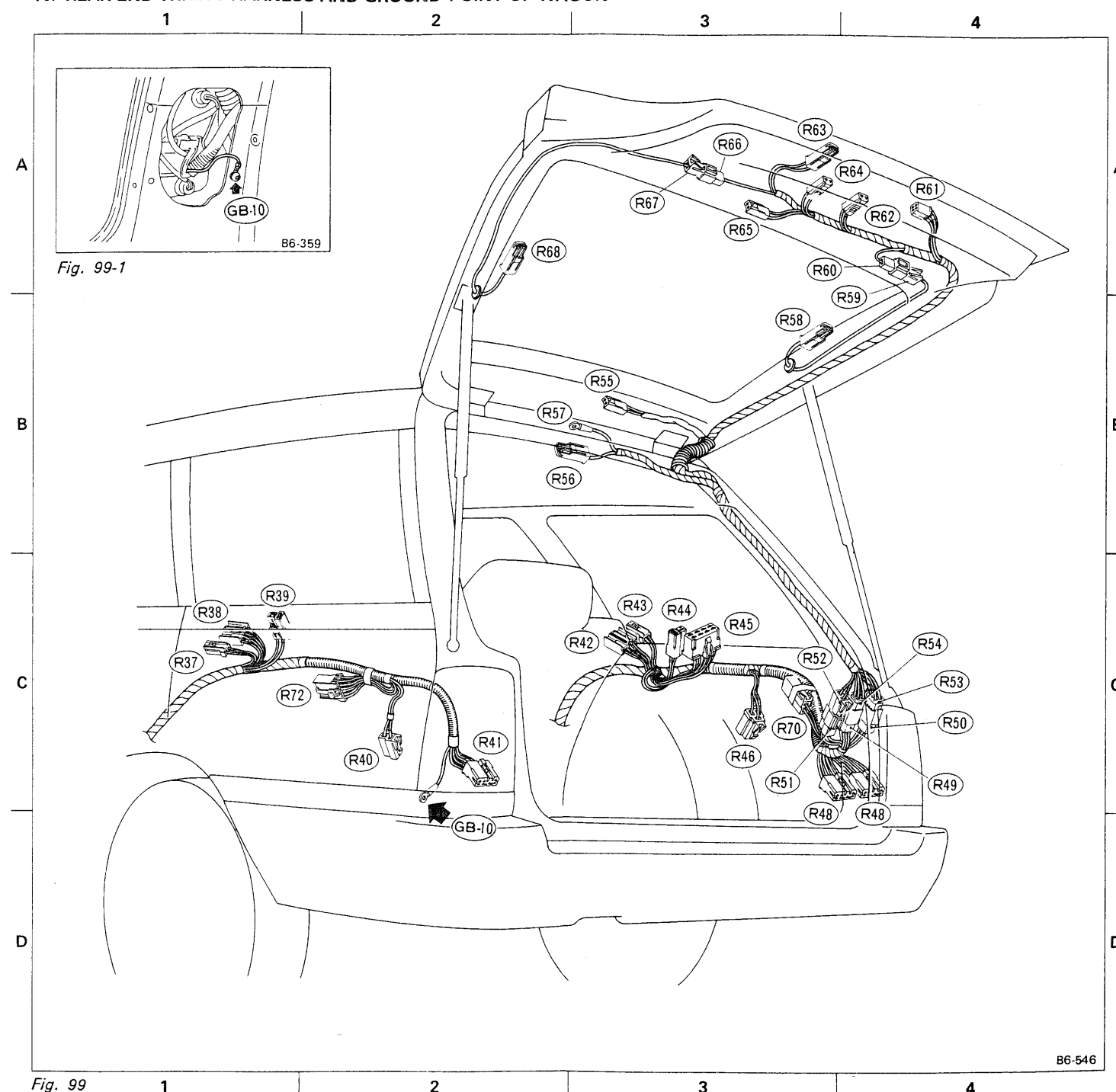
Connector				Connecting to	
No.	Pole	Color	Area	No.	Name
R23	3		B-2		Power-antenna
R24	1		A-2		Rear defogger (Ground)
R25	2	Black	B-2		Rear speaker LH
R27	2	Black	B-3		Trunk room light
R28	2	Black	B-3		Rear speaker RH
R29	1		A-3		Rear defogger (Power)
R32	9	Black	B-4		Rear combination light RH (with rear fog light)
	7		B-4		Rear combination light RH (without rear fog light)
R33	2		B-4		License plate light RH
R34	2		B-3		License plate light LH
R35	2		B-3		Trunk room light switch
R36	9	Black	B-2		Rear combination light LH (with rear fog light)
	7		B-3		Rear combination light LH (without rear fog light)
R69	2	Black	B-3		Condenser (Rear defogger)
R71	2		B-3		High-mount stop light
R72	10		C-4		Trailer connector (OP)

9. REAR END WIRING HARNESS AND GROUND POINT OF 4-DOOR SEDAN



Connector				Connecting to	
No.	Pole	Color	Area	No.	Name
R37	2	Black	C-1		A/S rear solenoid LH
R38	4	Black	C-1		A/S rear sensor LH
R39	2	Black	C-1		Rear speaker LH
R40	2	Green	C-2		Rear washer motor
R41	7		C-2		Rear combination light LH
R42	4	Black	C-3		A/S rear sensor RH
R43	2	Black	C-3		A/S rear solenoid RH
R44	2	Black	C-3		Rear speaker RH
R45	8	Black	C-3		Rear wiper relay (with INT.)
	5		C-3		Rear wiper relay (without INT.)
R46	3		C-3		Power-antenna
R48	7	Black	C-4		Rear combination light RH (with rear fog light)
	7		C-4		Rear combination light RH (without rear fog light)
R49	4		C-4	R54	
R50	6		C-4	R53	Rear gate cord
R51	2		C-3	R52	
R52	2		C-4	R51	
R53	6		C-4	R50	Rear wiring harness
R54	4		C-4	R49	
R55	2		B-3		High-mount stop light
R56	1	Black	B-3		Luggage room light
R57	1		B-3		
R58	1	Black	B-3		Rear defogger (Power)
R59	1		A-4	R60	Rear defogger cord
R60	1		A-4	R59	Rear gate cord
R61	4		A-4		Rear gate lock actuator
R62	2		A-4		License plate light RH
R63	2		A-3		Rear gate latch switch
R64	2		A-3		License plate light LH
R65	4		A-3		Rear wiper motor
R66	1		A-3	R67	Rear defogger cord
R67	1		A-3	R66	Rear gate cord
R68	1	Black	A-2		Rear defogger (Ground)
R70	2	Black	C-3		Condenser (Rear defogger)
R72	10		C-2		Trailer connector (OP)

10. REAR END WIRING HARNESS AND GROUND POINT OF WAGON





Publication No. G205AE ©
Issued: March 1993 A
Printed in Japan M-0.1



SUBARU[®]

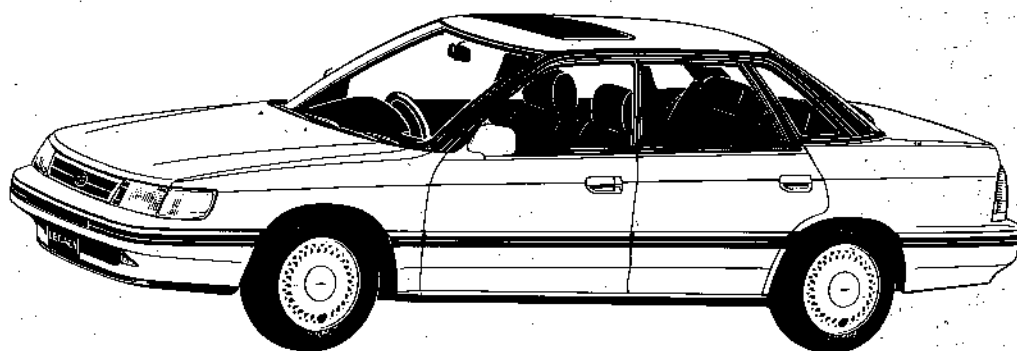
LEGACY

1992

SERVICE

MANUAL

SECTION 3



FUJI HEAVY INDUSTRIES LTD.

SUBARU®

1992

SERVICE MANUAL

FOREWORD

This service manual has been prepared to provide SUBARU service personnel with the necessary information and data for the correct maintenance and repair of SUBARU vehicle.

This manual includes the procedures for maintenance, disassembling, reassembling, inspection and adjustment of components and troubleshooting for guidance of both the fully qualified and the less-experienced mechanics.

Please peruse and utilize this manual fully to ensure complete repair work for satisfying our customers by keeping their vehicle in optimum condition. When replacement of parts during repair work is needed, be sure to use SUBARU genuine parts.

All information, illustration and specifications contained in this manual are based on the latest product information available at the time of publication approval.

FUJI HEAVY INDUSTRIES LTD.

All rights reserved. This book may not be reproduced or copied, in whole or in part, without the written permission of

FUJI HEAVY INDUSTRIES LTD., TOKYO JAPAN.

SUBARU,  and  are trademarks of FUJI HEAVY INDUSTRIES LTD.

© Copyright 1991 FUJI HEAVY INDUSTRIES LTD.

3 TRANSMISSION AND DIFFERENTIAL SECTION

MANUAL TRANSMISSION AND DIFFERENTIAL 3-1

AUTOMATIC TRANSMISSION AND DIFFERENTIAL (4AT) 3-2a

***** 3-2b

TRANSMISSION CONTROL SYSTEM 3-3

4WD SYSTEM 3-4

TABLE OF CONTENTS

	<ul style="list-style-type: none"> 1-1 Specifications 1-2 ★★★★★★★★★★ 1-3 General Information 1-4 Pre-Delivery Inspection 1-5 Periodic Maintenance Services 1-6 Special Tools
<p>2 ENGINE SECTION</p>	<ul style="list-style-type: none"> 2-1 Emission Control System and Vacuum Fitting 2-2 On-Car Services 2-3a Engine (SOHC) 2-3b Engine (DOHC) 2-4 Engine Lubrication System 2-5 Engine Cooling System 2-6 Carburetor 2-7a Fuel Injection System (MPFI Non-TURBO) 2-7b Fuel Injection System (SPFI) 2-7c Fuel Injection System (MPFI TURBO) 2-8 Fuel System 2-9 Exhaust System 2-10 Clutch 2-11 Engine and Transmission Mounting System
<p>3 TRANSMISSION AND DIFFERENTIAL SECTION</p>	<ul style="list-style-type: none"> 3-1 Manual Transmission and Differential 3-2a Automatic Transmission and Differential (4AT) 3-2b ★★★★★★★★★★ 3-3 Transmission Control System 3-4 4WD System
<p>4 MECHANICAL COMPONENTS SECTION</p>	<ul style="list-style-type: none"> 4-1 Suspension 4-2 Wheels and Axles 4-3 Steering System 4-4 Brakes 4-5 Pedal System and Control Cables 4-6 Heater and Ventilator 4-7 ★★★★★★★★★★
<p>5 BODY SECTION</p>	<ul style="list-style-type: none"> 5-1 Body and Exterior 5-2 Doors and Windows 5-3 Seats, Seat Belts, and Interior 5-4 Instrument Panel
<p>6 ELECTRICAL SECTION</p>	<ul style="list-style-type: none"> 6-1 Engine Electrical System 6-2 Body Electrical System 6-3 Wiring Diagram and Trouble-shooting

SUBARU®

1992

**SERVICE
MANUAL**



	Page
M MECHANISM AND FUNCTION	2
1. General	2
2. Center Differential	5
3. Reverse Check Mechanism	8
S SPECIFICATIONS AND SERVICE DATA	9
C COMPONENT PARTS	14
1. Transfer Case and Extension (Full-time 4WD)	14
2. Transfer Case and Extension (Selective 4WD)	15
3. Rear Case (FWD)	16
4. Transmission Case	17
5. Shifter Fork and Shifter Rod (4WD and 2000•2200cc FWD)	18
6. Shifter Fork and Shifter Rod (1600•1800cc FWD)	19
7. Drive Pinion ASSY (Full-time 4WD)	20
8. Drive Pinion ASSY (Selective 4WD)	21
9. Drive Pinion ASSY (2000•2200cc FWD)	22
10. Drive Pinion ASSY (1600•1800cc FWD)	23
11. Main Shaft ASSY (4WD Single-range and 2000•2200cc FWD)	24
12. Main Shaft ASSY (4WD Dual-range)	25
13. Main shaft ASSY (1600•1800cc FWD)	26
14. Center Differential	27
15. Front Differential	28
W SERVICE PROCEDURE	29
1. General	29
2. Transfer Case and Extension (Full-time 4WD)	31
3. Transfer Case and Extension (Selective 4WD)	38
4. Rear Case (FWD)	45
5. Transmission Case (4WD Single-range and 2000•2200cc FWD)	47
6. Transmission Case (4WD Dual-range)	56
7. Transmission Case (1600•1800cc FWD)	70
8. Drive Pinion ASSY (Full-time 4WD)	79
9. Drive Pinion ASSY (Selective 4WD)	84
10. Drive Pinion ASSY (2000•2200cc FWD)	86
11. Drive Pinion ASSY (1600•1800cc FWD)	88
12. Input Shaft ASSY (4WD Dual-range)	90
13. Main Shaft ASSY (4WD Dual-range)	92
14. Main Shaft ASSY (4WD Single-range and 2000•2200cc FWD)	95
15. Main Shaft ASSY (1600•1800cc FWD)	97
16. Center Differential (Full-time 4WD)	99
17. Front Differential	100
T TROUBLESHOOTING	103

2. FULL-TIME 4WD

The transmission which provides 4-wheel drive is a version of that used for front-wheel drive. It is a compact, "full-time" transmission that utilizes a center differential provided with a viscous coupling at the rear of a transfer unit. The viscous coupling serves as a differential-action control.

The center differential utilizes a highly reliable, bevel gear. It not only delivers an equal amount of drive power to both the front and rear, but controls the difference in rotating speed between the front and rear wheels. A viscous coupling and center differential gears are located in the center differential case to connect the

front and rear wheel drive shafts. With this arrangement, the transfer system realized a compact construction.

In addition, the viscous-coupling serves as a differential-action control to eliminate a mechanical lock mechanism. The major parts, such as the main case, mainshaft, front differential, etc., are the same types as those used with the transmission that provides front-wheel drive (FWD) for standardization purpose.

The dual-range model has an auxiliary transmission on the main shaft to enable selection of an overall gear ratio between the high and low gear ratios.

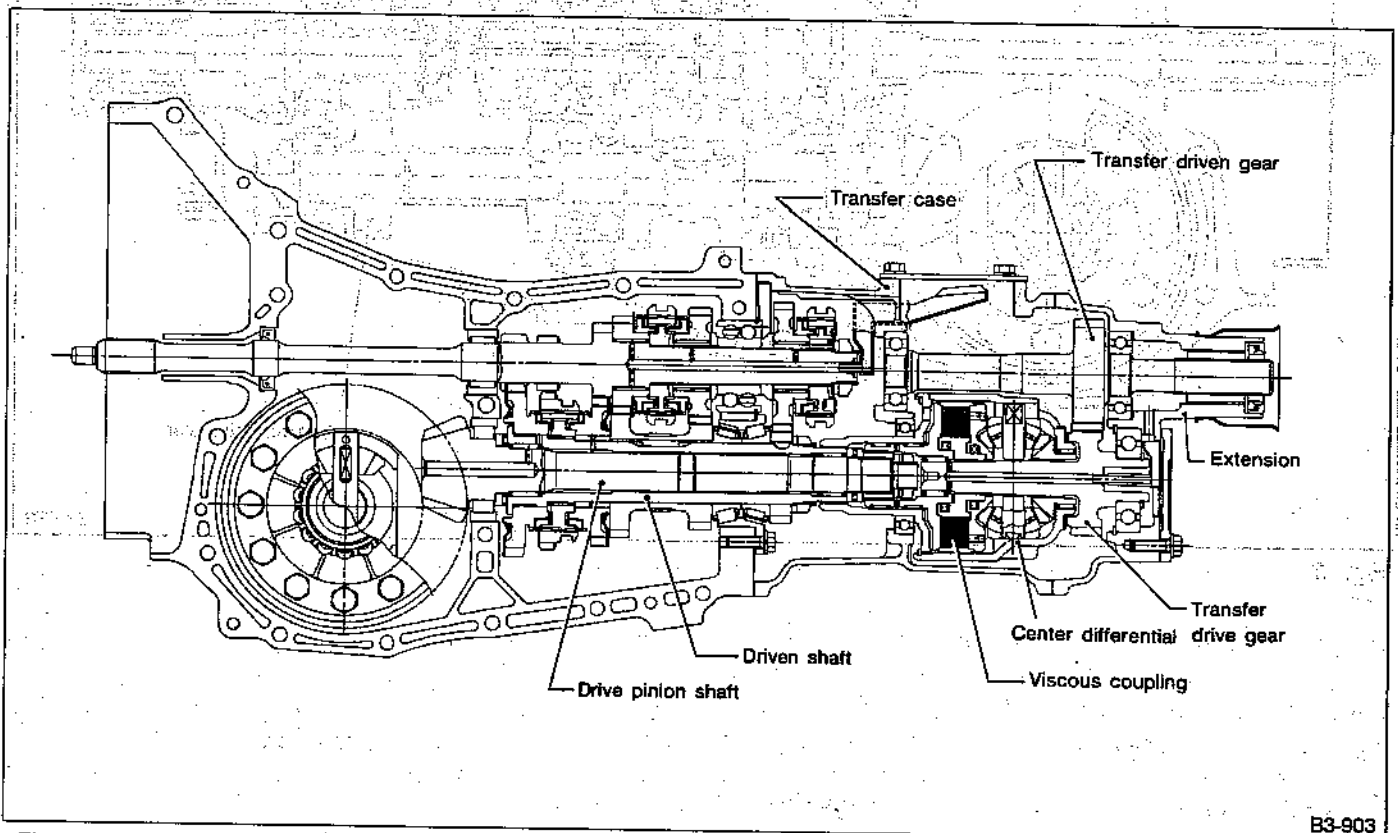


Fig. 2

B3-903

2. Center Differential

1. CONSTRUCTION

The center differential utilizes a "shaft-to-shaft" design which connects the front-wheel drive pinion shaft and the rear-wheel drive transfer drive gear shaft via viscous coupling to achieve compact construction. With this arrangement, viscous torque is generated by a difference in rotating speed between the two shafts so that both differential action and drive torque distribution are properly controlled. This contributes to

improvement of driving stability.

The center differential provides a means of distributing engine torque (transmitted to the tubular driven shafts by way of the clutch, mainshaft and various gears) to the front- and rear-wheel driven shafts equally, as well as absorbing the difference in rotating speed between the front and rear wheels during turns.

When the front and/or rear wheels spin on muddy roads, etc., viscous coupling controls the differential action so that the optimum drive torque is automatically distributed to these wheels.

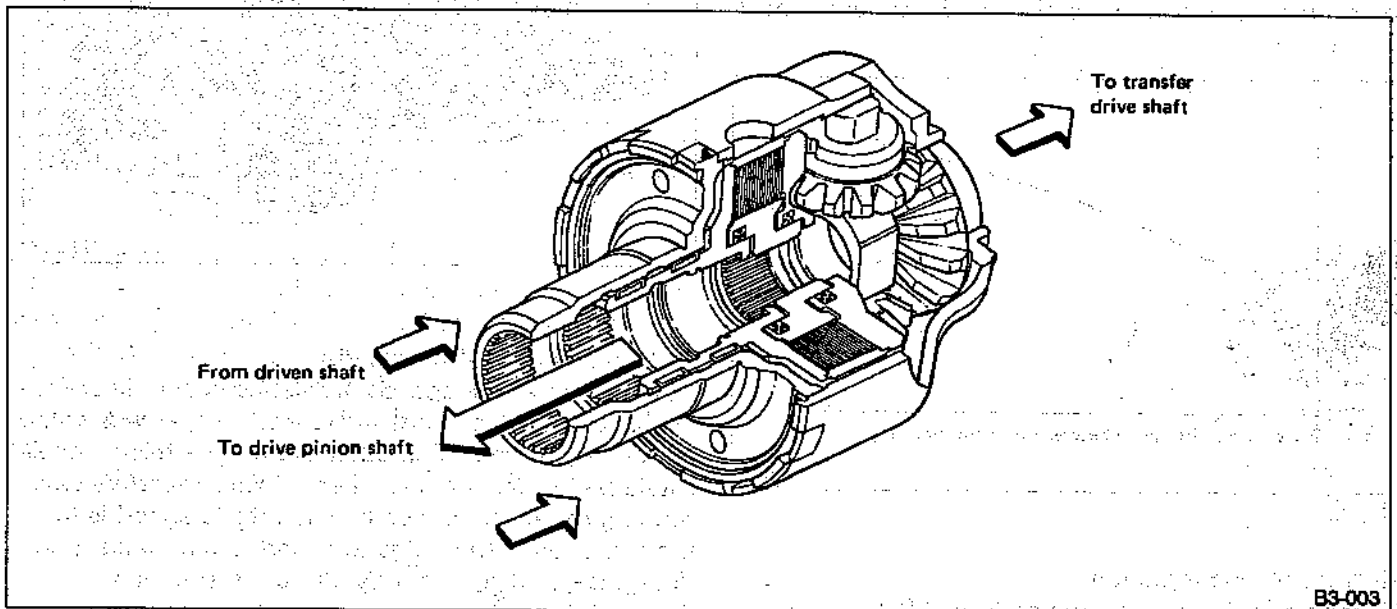


Fig. 4.

2. MECHANISM OF VISCOUS COUPLING

The viscous coupling housing contains a number of inner and outer plates which are arranged alternately. The inner plate has its internal perimeter fitted to the external hub splines while the outer plate has its external perimeter fitted to the internal housing splines. A spacer ring is used to separate the inner and outer plates. The inner plate has no spacer ring and moves

slightly between the adjacent outer plates, along the hub splined shaft in the axial direction.

A mixture of silicone oil and air is sealed in the space inside the viscous coupling housing. An "X" seal ring prevents silicone oil from entering the transmission. This could occur when silicone oil is highly pressurized due to an increase in rotating speed difference between the front and rear wheels.

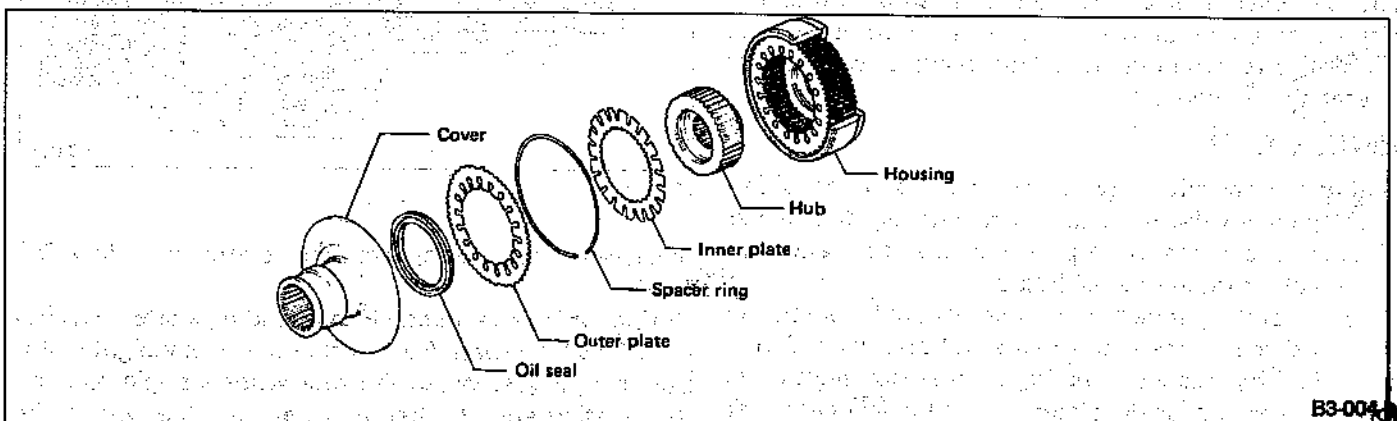


Fig. 5

1) Torque characteristics

When a difference in rotating speed between the viscous coupling housing and the hub occurs, a viscous shearing force is generated in the silicone oil between the outer and inner plates. The torque is then transmitted by the silicone oil between the housing and the hub. The greater the difference in rotating speed between the viscous coupling housing and the hub, the greater the shearing force of the silicone oil. The relationship between the torque transmission and rotation speed difference is shown in the figure. As can be seen from the figure, the smaller the rotating speed difference, the lesser the torque transmission and the differential action.

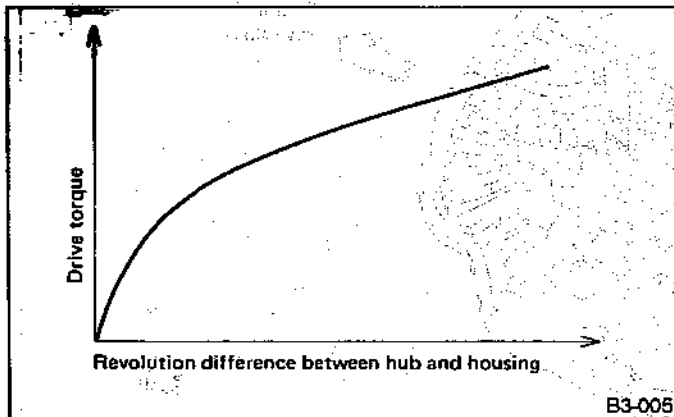


Fig. 6

2) "Hump" phenomenon

Silicone oil is heated and expands as differential action continues. This crushes air inside the viscous coupling so that the silicone oil "charging rate" will increase. As differential action continues, internal pressure will abruptly increase so that inner and outer plates (alternately arranged) come in contact. This causes quick torque transmission to occur, which is called a "hump" phenomenon.

"Hump" phenomenon eliminates the rotating speed difference between the housing and hub (which results in a state similar to "direct coupling"). This in turn decreases internal pressure and temperature. The viscous coupling returns to the normal operation. (The "hump" phenomenon does not occur under normal driving conditions.)

OPERATION

During normal driving (when there is no speed difference between the front and rear wheels), the center differential delivers drive power to the front and rear wheels at a torque ratio of 50:50.

When a rotating speed difference occurs between the front and rear wheels, the center differential action is controlled by viscous coupling so that optimum drive forces are automatically distributed to the front and rear wheels.

1) During normal driving

During normal straight driving (on flat roads at constant speed), all four wheels rotate at the same speed. The center differential delivers engine torque to the front and rear drive axles. The viscous coupling does not perform the differential-action control because there is no rotating speed difference between the front and rear drive shafts.

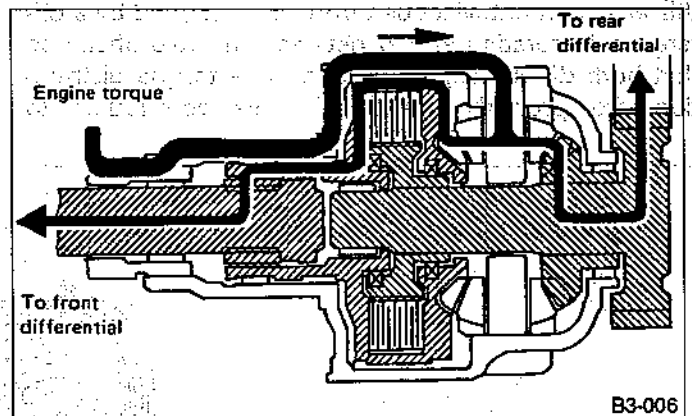


Fig. 7

2) During turns at low speeds

During turns at low speeds, a rotating speed difference occurs between the front and rear wheels, as well as the left and right wheels. In other words, the front wheels rotate faster than the rear wheels. When there is a small rotating speed difference (when vehicle speed is low), the center differential acts to absorb the rotating speed difference, making it possible to drive smoothly.

Although a slight rotating speed difference is transmitted to the viscous coupling, less torque transmission occurs because of the small rotating speed difference.

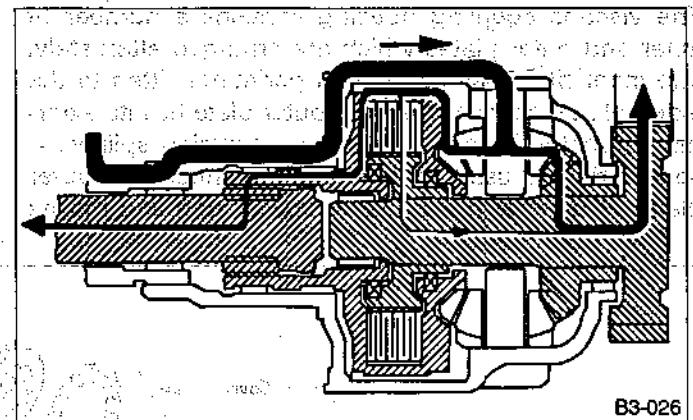


Fig. 8

3) Acceleration during standing starts on a low "μ" road

During rapid acceleration from standing starts on a slippery (low "μ") road, front and rear wheel weight distribution changes. When the rear wheels begin to spin, the rotating speed difference between the two shafts increase simultaneously. This causes the viscous coupling to activate to that more torque is transmitted to

the front wheels than to the rear wheels. In addition, the center-differential's action is also restricted. In this way, acceleration performance during standing starts on low "μ" roads is greatly enhanced.

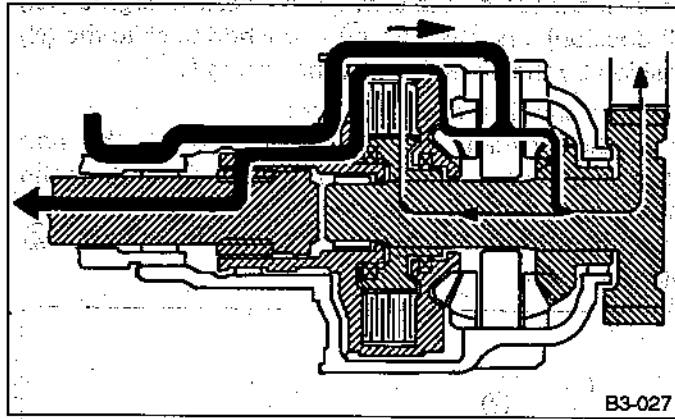


Fig. 9.

4) Driving on rough roads

When one of the wheels begins to spin during rough-road driving, the rotating speed difference between the shafts is increased by the differential's action. At this point, the viscous coupling delivers large torque to the differential on the side which is not spinning. In this way, driving stability on rough roads is increased (The figure below shows an example of front wheel slip.)

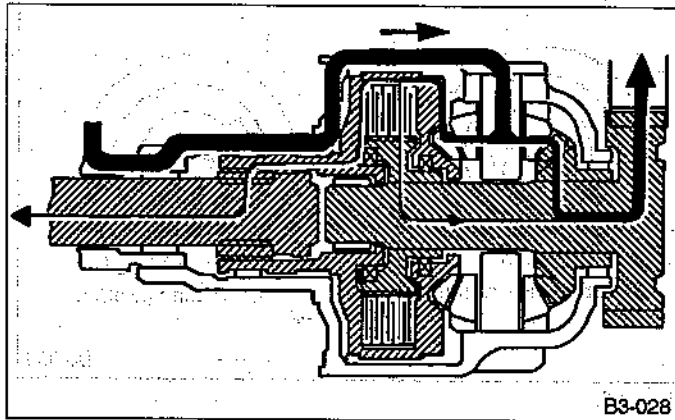
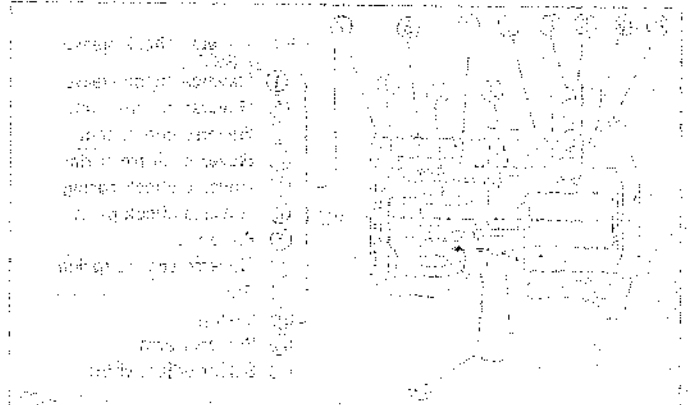


Fig. 10

[Faint, mostly illegible text, likely bleed-through from the reverse side of the page.]



[Faint, mostly illegible text, likely bleed-through from the reverse side of the page.]

3. Reverse Check Mechanism

1. When 5th and reverse side is selected
 The arm ⑪ is pushed to the transmission case. The sleeve ① is pushed to the left by the sleeve ①. On the smaller diameter part of shaft ②, the cam ③ is pushed to the left so that it can rotate, and the sleeve ① is pushed back in place with its stepped part. The selector arm ⑪, which is inserted in the shaft ② presses the sleeve ① to the left. Further, the spring ⑤ is placed in the groove of the cam ③ and sleeve ①, which forces the sleeve ① to the left and in the direction of rotation. Both the sleeve ① and cam ③ are held down with the plate ⑥ that is attached to the sleeve ① with the snap ring ⑦. The shaft ② has a groove for reverse accent, in which the ball ⑨ and spring ⑧ are put through a hole drilled in the sleeve ①

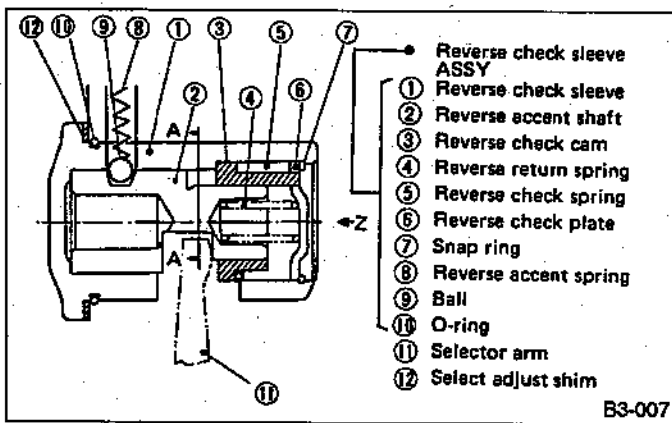


Fig. 11

2. OPERATION

As shown in Fig. 11, the sleeve ① and shaft ② have a notch, and the arm ⑪ is placed between the notches. The position of the arm ⑪ shown in Fig. 11 is the neutral position (hereafter referred to as (N) position). The point where the arm stops when moved to the left is the 1st and 2nd position. Opposite this, the point where the arm stops when moved to the right is the 5th and reverse position. Fig. 12 shows the section A-A in Fig. 11, and Fig. 13 the view Z in Fig. 11.

- 1) When 5th and reverse side is selected
 The arm ⑪ pushes the shaft ② and cam ③ simultaneously and moves to the 5th and reverse side, as shown in [Fig. 12-(1)].
- 2) When shift is made to 5th
 As shown in [Fig. 12-(2)], the arm ⑪ moves to the 5th side pushing the shaft ②. When the arm ⑪ pulls out of the cam ③, the cam is returned to the original position by the spring ⑤.
- 3) When shift is made from 5th to reverse.
 As shown in [Fig. 12-(3)], the arm ⑪ moves to the reverse side pushing the shaft ② and runs against the

cam ③ that has already returned. The cam ③ has, as shown in [Fig. 13], a stopper, which hits against the plate ⑥. Thus, the cam ③ cannot rotate further. Accordingly, the arm ⑪ comes to a stop at a point where it has turned the cam ③ to a certain degree (i.e., (N) position), and the cam ③ is pushed back to the (N) position by the shaft ② (i.e., the spring ④).

4) When shift is made to reverse
 From the position shown in [Fig. 12-(1)], the arm ⑪ again moves to the 5th and reverse side. When the shift is made to reverse, the arm ⑪ moves to the reverse position while pushing the shaft ② and cam ③ together.

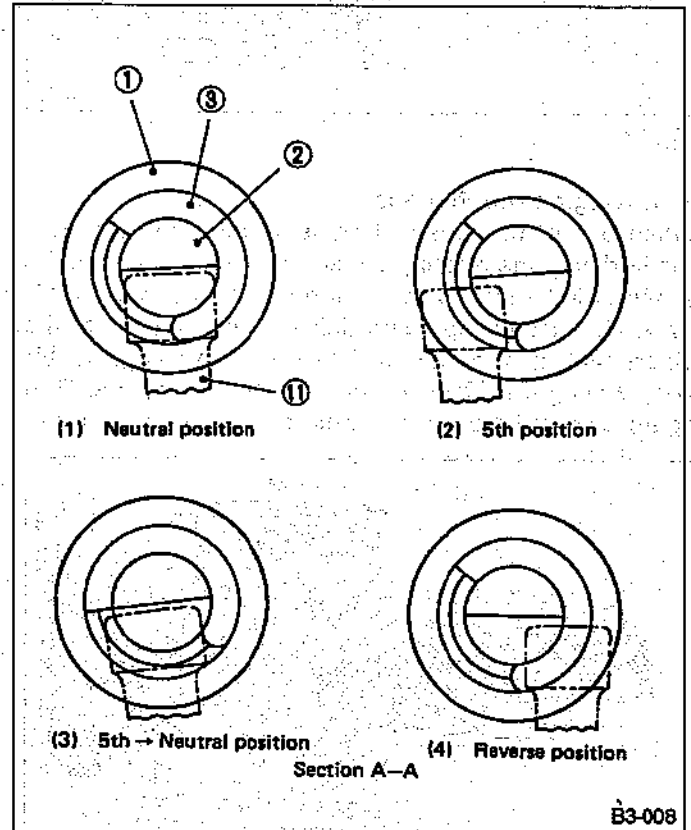


Fig. 12

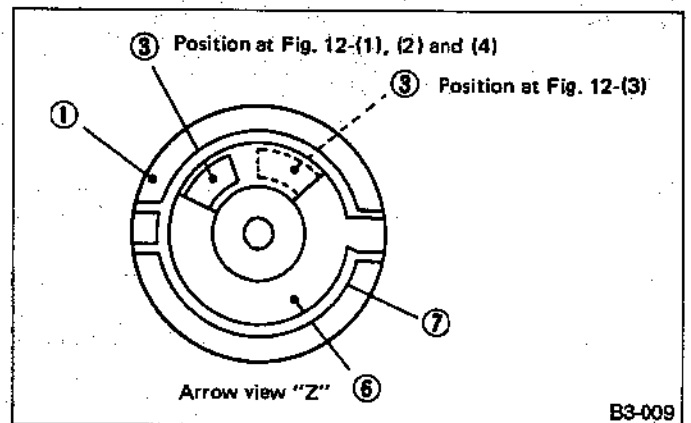


Fig. 13

S SPECIFICATIONS AND SERVICE DATA

A: SPECIFICATIONS

Item	Model	FWD				4WD			
		1600cc	1800cc	2000cc	2200cc	1900cc	2000cc	2200cc	TURBO
Type		5-forward speeds with synchromesh and 1-reverse *1 (5 x 2-forward speeds with synchromesh and 1-reverse)							
Transmission gear ratio	1st	3.836			3.545			3.545	
	2nd	2.105			2.111			1.947	
	3rd	1.428			1.448			1.366	
	4th	1.093			1.088			0.972	
	5th	0.885			0.871			0.780	
	Reverse	3.583			3.416			3.416	
*1 Auxiliary transmission gear ratio	High	—			1.000	1.000		—	
	Low	—			1.592	1.196		—	
Front reduction gear	Final	Type of gear	Hypoid						
		Gear ratio	4.111	3.900	3.700		4.111		3.900
Rear reduction gear	Transfer	Type of gear	—			Helical			
		Gear ratio	—			1.000		1.100	
	Final	Type of gear	—			Hypoid			
		Gear ratio	—			4.111		3.900	3.545
Front differential	Type and number of gear	Straight bevel gear (Bevel pinion: 2, Bevel gear: 2)							
*2 Center differential	Type and number of gear	—			Straight bevel gear (Bevel pinion: 2, Bevel gear: 2 and viscous coupling)				
Rear differential	Type and number of gear	—			Straight bevel gear (Bevel pinion: 2, Bevel gear: 2)				
Transmission oil capacity		2.6 l (2.7 US qt, 2.3 Imp qt)		3.3 l (3.5 US qt, 2.9 Imp qt)		*2 3.5 l (3.7 US qt, 2.1 Imp qt) *3 3.3 l (3.5 US qt, 2.9 Imp qt)			
Rear differential gear oil capacity		—			0.8 l (0.8 US qt, 0.7 Imp qt)				

*1: Dual-range model only

*2: Full time 4WD only

*3: Selective 4WD only

Full-time 4WD)

to ball bearing side clearance:
0.15 mm (0.0059 in)

Snap ring (Inner-72)	
Part No.	Thickness mm (in)
805172071	1.78 (0.0701)
805172072	1.90 (0.0748)
805172073	2.02 (0.0795)

to ball bearing side clearance:
0.15 mm (0.0059 in)

Snap ring (Outer-30)	
Part No.	Thickness mm (in)
805030041	1.53 (0.0602)
805030042	1.65 (0.0650)
805030043	1.77 (0.0697)

2. TRANSFER CASE AND EXTENSION ASSY (Full-time 4WD)

Center differential washer to thrust bearing clearance:
0.35 — 0.55 mm (0.0138 — 0.0217 in)

Center differential washer	
Part No.	Thickness mm (in)
38965AA080	1.25 (0.0492)
38965AA090	1.40 (0.0551)
38965AA101	1.55 (0.0610)
38965AA110	1.70 (0.0669)
38965AA120	1.85 (0.0728)

to ball bearing side clearance:
0.25 — 0.30 mm (0.0020 — 0.0118 in)

Thrust washer (52 x 61 x t)	
Part No.	Thickness mm (in)
803052021	0.50 (0.0197)
803052022	0.75 (0.0295)
803052023	1.00 (0.0394)

TRANSFER CASE OR REAR CASE

Adjustment

Adjustment shim	
Part No.	Thickness mm (in)
803020151	0.15 (0.0059)
803020152	0.30 (0.0118)

Reverse accent shaft (4WD and 2000*2200cc FWD)

Part No.	Mark	Remarks
32188AA020	A	Neutral position is closer to 1st.
32188AA002	No mark or B	Standard
32188AA030	C	Neutral position is closer to reverse.

Reverse accent shaft (1600*1800cc FWD)

Part No.	Mark	Remarks
32188AA040	1	Neutral position is closer to 1st gear.
32188AA011	2	Standard
32188AA050	3	Neutral position is closer to reverse gear.

Reverse check plate adjustment

Reverse check plate			
Part No.	Mark	Angle θ	Remarks
32189AA000	0	28°	Arm stops closer to 5th gear.
32189AA010	1	31°	Arm stops closer to 5th gear.
33189AA020	2	34°	Arm stops in the center.
32189AA030	3	37°	Arm stops closer to reverse gear.
32189AA040	4	40°	Arm stops closer to reverse gear.

4. REVERSE IDLER GEAR (4WD and 2000*2200cc FWD)

Adjustment of reverse idler gear position

Reverse idler gear CP to transmission case (LH) wall clearance:
6.0 — 7.5 mm (0.236 — 0.295 in)

Reverse shifter lever		
Part No.	Mark	Remarks
32820AA000	0	Further from case wall
32820AA010	No mark	Standard
32820AA020	2	Closer to the case wall

After installing a suitable reverse shifter lever, adjust reverse idler gear-to-transmission case wall clearance to within 0 to 0.5 mm (0 to 0.020 in) using washers.

Washer (20.5 x 26 x t)

Part No.	Thickness mm (in)	Part No.	Thickness mm (in)
803020151	0.4 (0.016)	803020154	1.9 (0.075)
803020152	1.1 (0.043)	803020155	2.3 (0.091)
803020153	1.5 (0.059)		

5. REVERSE IDLER GEAR (1600-1800cc FWD)

Adjustment of reverse idler gear CP position

Reverse idler gear CP to transmission case (LH) wall clearance
1.5 — 3.0 mm (0.059 — 0.118 in)

Reverse shifter lever		
Part No.	Mark	Remarks
440627101	1	Further from case wall
440627102	2 or No mark	Standard
440627103	3	Closer to the case wall

After installing a suitable reverse shifter lever, adjust reverse idler gear-to-transmission case wall clearance to within 0 to 0.5 mm (0 to 0.020 in) using washers, 5-speed models.

Washer (15.5 x 21 x t)			
Part No.	Thickness mm (in)	Part No.	Thickness mm (in)
803015081	0.6 — 0.8 (0.024 — 0.031)	803015084	1.8 — 2.0 (0.071 — 0.079)
803015082	1.0 — 1.2 (0.039 — 0.047)	803015085	2.2 — 2.4 (0.087 — 0.094)
803015083	1.4 — 1.6 (0.055 — 0.063)		

6. SHIFTER FORK AND ROD (4WD and 2000-2200cc FWD)

Select suitable shifter forks so that both coupling sleeve and reverse driven gear are positioned in the center of their synchromesh mechanisms.

1st-2nd shifter fork CP		
Part No.	Mark	Remarks
32804AA060	1	Approach to 1st gear by 0.2 mm (0.008 in)
32804AA070	No mark	Standard
32804AA080	3	Approach to 2nd gear by 0.2 mm (0.008 in)

3rd-4th shifter fork CP		
Part No.	Mark	Remarks
32810AA060	1	Approach to 4th gear by 0.2 mm (0.008 in)
32810AA070	No mark	Standard
32810AA100	3	Approach to 3rd gear by 0.2 mm (0.008 in)

5th shifter fork CP		
Part No.	Mark	Remarks
32812AA060	1	Approach to 5th gear by 0.2 mm (0.008 in)
32812AA070	No mark	Standard
32812AA100	3	Become distant from 5th gear by 0.2 mm (0.008 in)

Rod end clearance

A: 1st-2nd — 3rd-4th

0.5 — 1.5 mm (0.020 — 0.059 in)

B: 3rd-4th — 5th

0.6 — 1.4 mm (0.024 — 0.055 in)

7. SHIFTER FORK AND ROD (1600-1800cc FWD)

Select suitable shifter forks so that both coupling sleeve and reverse driven gear are positioned in the center of their synchromesh mechanisms.

1st-2nd shifter fork CP		
Part No.	Mark	Remarks
32804AA001	1	Approach to 2nd gear 0.3 mm (0.012 in)
32804AA011	No mark	Standard
32804AA021	3	Approach to 1st gear 0.3 mm (0.012 in)

3rd-4th shifter fork CP		
Part No.	Mark	Remarks
32810AA110	1	Approach to 4th gear by 0.6 mm (0.024 in)
32810AA120	2	Approach to 4th gear by 0.3 mm (0.012 in)
32810AA130	No mark	Standard
32810AA140	4	Approach to 3rd gear by 0.3 mm (0.012 in)
32810AA150	5	Approach to 3rd gear by 0.6 mm (0.024 in)

Select a suitable 5th shifter fork so that coupling sleeve-to-5th driven gear clearance is within 1.2 to 1.5 mm (0.047 to 0.059 in), 5-speed models.

5th shifter fork CP		
Part No.	Mark	Remarks
32812AA032	1	Approach to gear side by 0.3 mm (0.012 in)
32812AA042	No mark	Standard
32812AA052	3	Become distant from gear side by 0.3 mm (0.012 in)

Rod end clearance

A & B: 0.3 — 1.6 mm (0.012 — 0.063 in)

8. TRANSMISSION CASE ASSEMBLY (4WD and 2000-2200cc FWD)

Drive pinion shim adjustment

Drive pinion shim			
Thickness mm (in)	Part No.	Thickness mm (in)	
0.150 (0.0059)	32295AA071	0.250 (0.0098)	
0.175 (0.0069)	32295AA081	0.275 (0.0108)	
0.200 (0.0079)	32295AA091	0.300 (0.0118)	
0.225 (0.0089)	32295AA101	0.500 (0.0197)	

Hypoid gear backlash:

0.13 — 0.18 mm (0.0051 — 0.0071 in)

Selection of main shaft rear plate

Main shaft rear plate		
Dimension "A" mm (in)	Part No.	Mark
4.00 — 4.13 (0.1575 — 0.1626)	32294AA040	1
3.87 — 3.99 (0.1524 — 0.1571)	32294AA050	2

Snap ring (Outer—19) to counter washer clearance [4WD Dual-range only]

0.05—0.35mm(0.0020 — 0.0138in)

Snap ring (Outer — 19)	
Part No.	Thickness mm(in)
031319000	1.50(0.0591)
805019010	1.72(0.0677)

Input shaft holder adjustment [4WD Dual-range only]

Dimension "D" mm (in)	Number of shim
52.46 — 53.23 (2.0654 — 2.0957)	Nothing
51.96 — 52.45 (2.0457 — 2.0650)	1
51.34 — 51.95 (2.0213 — 2.0453)	2

9. TRANSMISSION CASE ASSEMBLY (1600-1800cc FWD)

Drive pinion shim adjustment

Drive pinion shim	
Part No.	Thickness mm (in)
32295AA110	0.15 (0.0059)
32295AA120	0.175 (0.0069)
32295AA130	0.20 (0.0079)
32295AA140	0.225 (0.0089)
32295AA150	0.25 (0.0098)
32295AA160	0.275 (0.0108)
32295AA170	0.30 (0.0118)
32295AA180	0.50 (0.0197)

Hypoid gear backlash:

0.13 — 0.18 mm (0.0051 — 0.0071 in)

Selection of main shaft rear plate

Main shaft rear plate		
Dimension "A" mm (in)	Part No.	Mark
4.50 — 4.63 (0.1772 — 0.1823)	441347001	T81-1
4.37 — 4.50 (0.1720 — 0.1772)	441347002	T81-2

10. DRIVE PINION ASSY (Full-time 4WD)

Preload adjustment of thrust bearing:

Starting torque

0.3 — 0.8 N·m (3 — 8 kg-cm, 2.6 — 6.9 in-lb)

Adjusting washer No. 1	
Part No.	Thickness mm (in)
803025051	3.925 (0.1545)
803025052	3.950 (0.1555)
803025053	3.975 (0.1565)
803025054	4.000 (0.1575)
803025055	4.025 (0.1585)
803025056	4.050 (0.1594)
803025057	4.075 (0.1604)

Adjusting washer No. 2	
Part No.	Thickness mm (in)
803025059	3.850 (0.1516)
803025054	4.000 (0.1575)
803025058	4.150 (0.1634)

Assemble a driven shaft and 1st driven gear that are selected for the proper radial clearance adjustment.

Driven shaft		1st driven gear	
Part No.	Diameter A mm (in)	Part No.	Spec.
32229AA130	49.959 — 49.966 (1.9669 — 1.9672)	32231AA270	Non-turbo
		32231AA290	Turbo
32229AA120	49.967 — 49.975 (1.9672 — 1.9675)	32231AA260	Non-turbo
		32231AA280	Turbo

11. DRIVE PINION ASSY (Selective 4WD and 2000-2200cc FWD)

Selection of 1st driven gear:

1st driven gear	
Outer diameter of bushing mm (in)	Part No.
41.983 — 41.996 (1.6529 — 1.6534)	32231AA320
41.968 — 41.982 (1.6523 — 1.6528)	32231AA330
41.954 — 41.967 (1.6517 — 1.6522)	32231AA340

12. INPUT SHAFT ASSY (4WD Dual-range)

Input shaft cotter to ball bearing clearance
0 — 0.09 mm (0 — 0.0031 in)

Input shaft cotter			
Part No.	Thickness mm (in)	Part No.	Thickness mm (in)
35204AA000	2.43 (0.0957)	35204AA020	2.59 (0.1020)
35204AA010	2.51 (0.0988)		

Snap ring (Inner-56) to bearing clearance
0 — 0.08 mm (0 — 0.0031 in)

Snap ring (Inner-62)			
Part No.	Thickness mm (in)	Part No.	Thickness mm (in)
805162011	1.75 (0.0689)	805162013	1.91 (0.0752)
805162012	1.83 (0.0720)		

13. MAIN SHAFT (4WD Dual-range)

Snap ring (Outer-25) to synchronizer hub clearance
0.060 — 0.100 mm (0.0024 — 0.0039 in)

Snap ring (Outer-25)			
Part No.	Thickness mm (in)	Part No.	Thickness mm (in)
805025051	2.42 (0.0953)	805025055	2.62 (0.1031)
805025052	2.47 (0.0972)	805025056	2.67 (0.1051)
805025053	2.52 (0.0992)	805025057	2.72 (0.1071)
805025054	2.57 (0.1012)	805025058	2.37 (0.0933)

14. CENTER DIFFERENTIAL

Snap ring (Inner-110) to center differential case clearance:
0 — 0.15 mm (0 — 0.0059 in)

Snap ring (Inner-110)	
Part No.	Thickness mm (in)
805100061	2.10 (0.0827)
805100062	2.21 (0.0870)
805100063	2.32 (0.0913)

Backlash adjustment axial movement:
0.62 — 0.86 mm (0.0244 — 0.0339 in)

Adjusting washer (45 x 62 x t)	
Part No.	Thickness mm (in)
803045041	1.60 (0.0630)
803045042	1.80 (0.0709)
803045043	2.00 (0.0787)
803045044	2.20 (0.0866)
803045045	2.40 (0.0945)

15. FRONT DIFFERENTIAL (4WD and 2000-2200cc FWD)

Bevel gear to pinion backlash
0.13 — 0.18 mm (0.0051 — 0.0071 in)

Washer (38.1 x 50 x t)			
Part No.	Thickness mm (in)	Part No.	Thickness mm (in)
803038021	0.925 — 0.950 (0.0364 — 0.0374)	803038023	1.025 — 1.050 (0.0404 — 0.0413)
803038022	0.975 — 1.000 (0.0384 — 0.0394)		

Pinion shaft to axle drive shaft clearance
0 — 0.2 mm (0 — 0.008 in)

Snap ring (Outer-28)			
Part No.	Thickness mm (in)	Part No.	Thickness mm (in)
805028011	1.05 (0.0413)	805028012	1.20 (0.0472)

16. FRONT DIFFERENTIAL (1600-1800cc FWD)

Bevel gear to pinion backlash
0.13 — 0.18 mm (0.0051 — 0.0071 in)

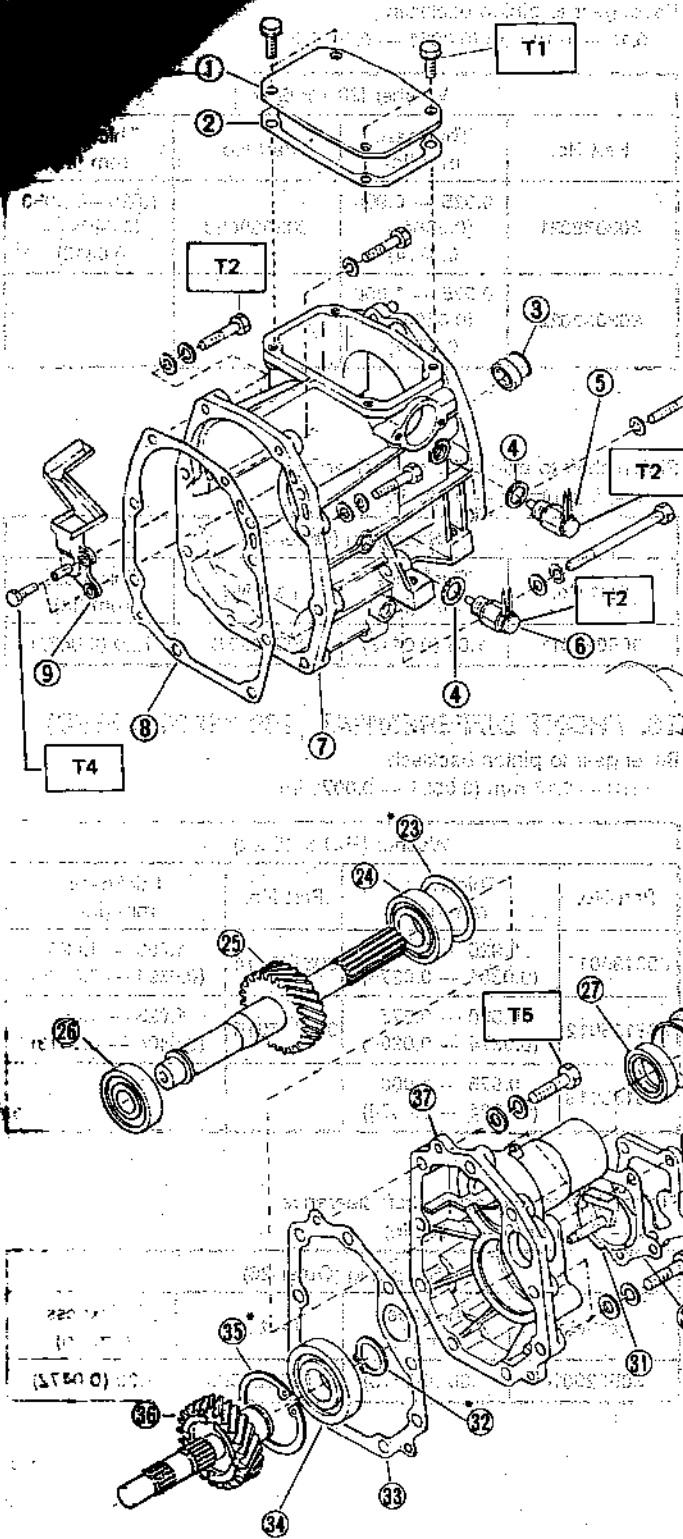
Washer (35.1 x 45 x t)			
Part No.	Thickness mm (in)	Part No.	Thickness mm (in)
803135011	0.925 — 0.950 (0.0364 — 0.0374)	803135014	1.000 — 1.025 (0.0394 — 0.0404)
803135012	0.950 — 0.975 (0.0374 — 0.0384)	803135015	1.025 — 1.050 (0.0404 — 0.0413)
803135013	0.975 — 1.000 (0.0384 — 0.0394)		

Pinion shaft to axle drive shaft clearance
0 — 0.2 mm (0 — 0.008 in)

Snap ring (Outer-26)			
Part No.	Thickness mm (in)	Part No.	Thickness mm (in)
805026010	1.05 (0.0413)	031526000	1.20 (0.0472)

COMPONENT PARTS

Transfer Case and Extension (Full-time 4WD)



Transfer Case (CP)		Extension (CP)	
1	Transfer cover	1	Transfer cover
2	Cover gasket	2	Cover gasket
3	Oil seal	3	Oil seal
4	Gasket	4	Gasket
5	Neutral switch	5	Neutral switch
6	Back-up light switch	6	Back-up light switch
7	Transfer case CP	7	Transfer case CP
8	Gasket	8	Gasket
9	Oil guide	9	Oil guide
10	Ball	10	Ball
11	Reverse accent spring	11	Reverse accent spring
12	Gasket	12	Gasket
13	Plug	13	Plug
14	Snap ring (IN)	14	Snap ring (IN)
15	Reverse check plate	15	Reverse check plate
16	Reverse checking spring	16	Reverse checking spring
17	Reverse return spring	17	Reverse return spring
18	Reverse checking cam	18	Reverse checking cam
19	Reverse accent shaft	19	Reverse accent shaft
20	O-ring	20	O-ring
21	Adjusting select shim	21	Adjusting select shim
22	Reverse checking sleeve	22	Reverse checking sleeve
23	Adjusting washer	23	Adjusting washer
24	Ball bearing	24	Ball bearing
25	Transfer driven gear	25	Transfer driven gear
26	Ball bearing	26	Ball bearing
27	Oil seal	27	Oil seal
28	Shift-bracket	28	Shift-bracket
29	Extension cover	29	Extension cover
30	Gasket	30	Gasket
31	Oil guide	31	Oil guide
32	Snap ring (Outer - 30)	32	Snap ring (Outer - 30)
33	Gasket	33	Gasket
34	Ball bearing	34	Ball bearing
35	Snap ring (Inner - 72)	35	Snap ring (Inner - 72)
36	Transfer drive gear	36	Transfer drive gear
37	Extension CP	37	Extension CP

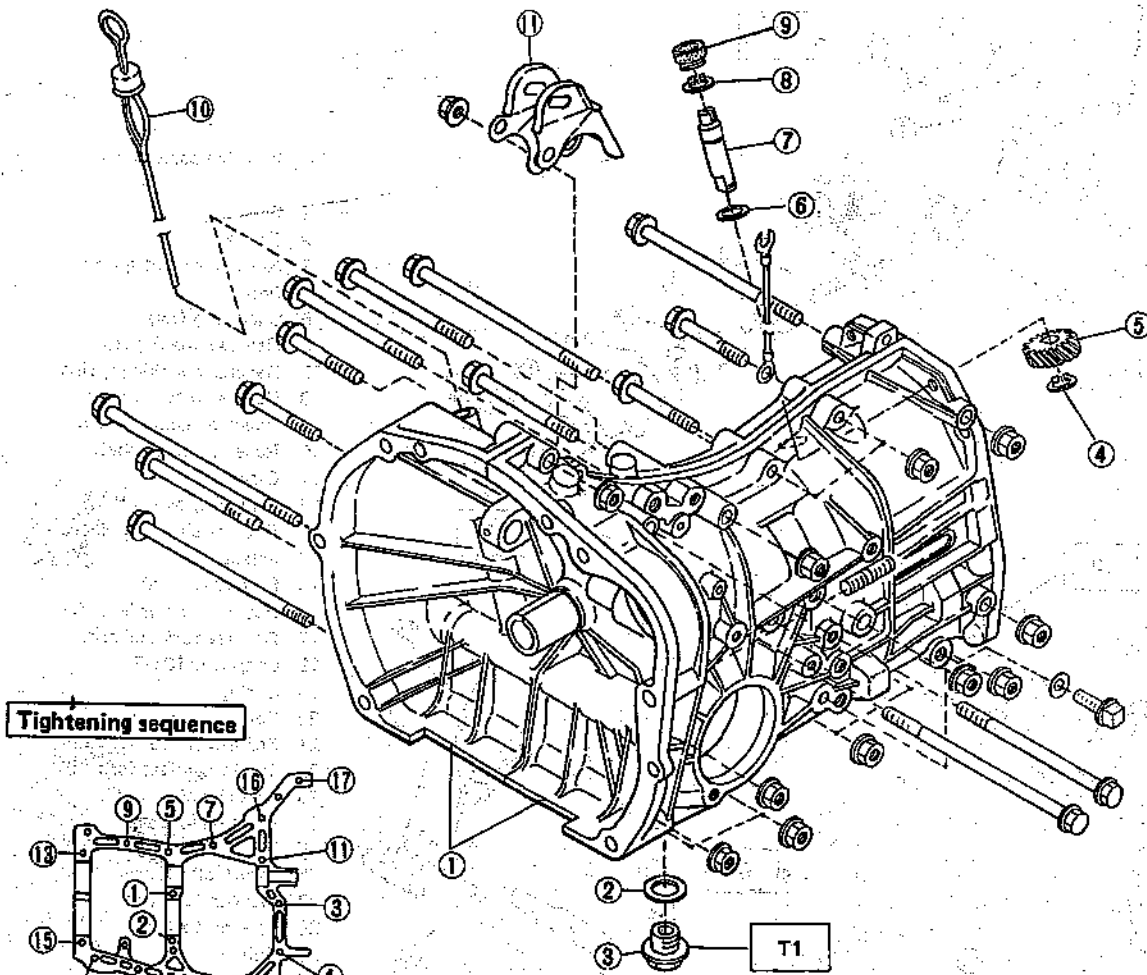
Tightening torque: N-m (kg-m, ft-lb)

T1	14.2 - 17.2 (1.45 - 1.75, 10.5 - 12.7)
T2	23 - 26 (2.3 - 2.7, 17 - 20)
T3	9 - 11 (0.9 - 1.1, 6.5 - 8.0)
T4	6 - 7 (0.6 - 0.7, 4.3 - 5.1)
T5	34 - 40 (3.5 - 4.1, 25 - 30)

Fig. 14

B3-010

4. Transmission Case

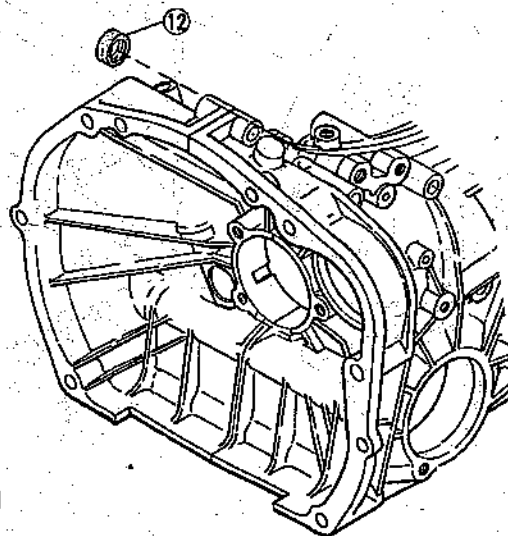


Tightening sequence

Size	All models	Torque
8 mm bolt	⑤ - ⑮	23 - 26 N·m (2.3 - 2.7 kg·m, 17 - 20 ft·lb)
10 mm bolt	① - ④ ⑯ - ⑰	36 - 42 N·m (3.7 - 4.3 kg·m, 27 - 31 ft·lb)

Tightening torque: N·m (kg·m, ft·lb)
T1: 41 - 47 (4.2 - 4.8, 30 - 35)

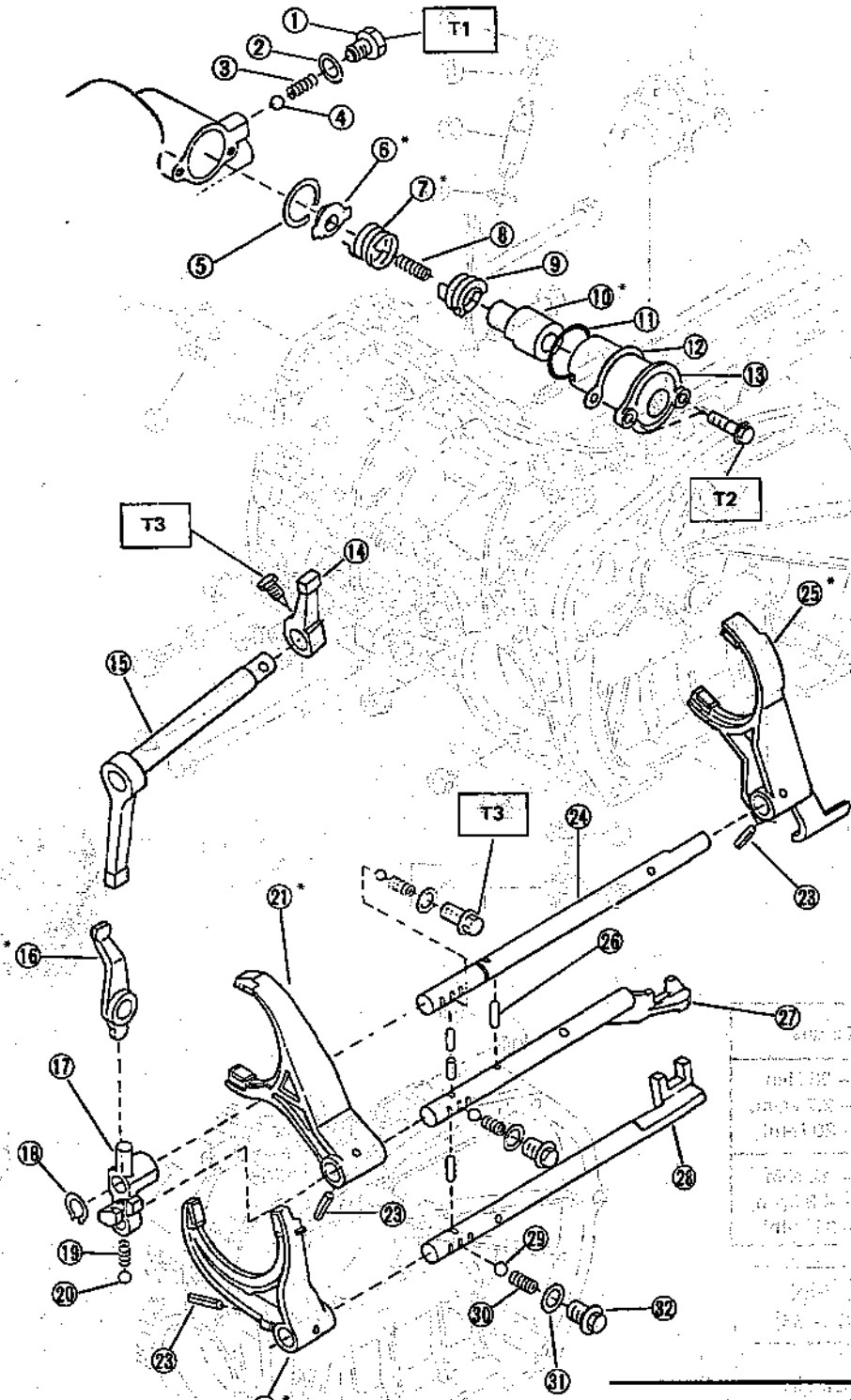
- 1 Transmission case ASSY
- 2 Gasket
- 3 Drain plug
- 4 Snap ring (OUT)
- 5 Speedometer driven gear
- 6 Washer
- 7 Speedometer shaft
- 8 Snap ring (OUT)
- 9 Oil seal
- 10 Oil level gauge
- 11 Pitching stopper bracket
- 12 Oil seal [4WD Dual-range]



[4WD Dual-range]

Fig. 17

5. Shifter Fork and Shifter Rod (4WD and 2000•2200cc FWD)



*: Selective parts

- 1 Plug
- 2 Gasket
- 3 Reverse accent spring
- 4 Ball
- 5 Snap ring (IN)
- *6 Reverse check plate
- *7 Reverse checking spring
- 8 Reverse return spring
- 9 Reverse checking cam
- *10 Reverse accent shaft
- 11 O-ring
- 12 Adjusting select shim
- 13 Reverse checking sleeve
- 14 Selector arm
- 15 Shifter arm CP
- *16 Reverse shifter lever CP
- 17 Reverse fork rod arm
- 18 Snap ring (OUT)
- 19 Spring
- 20 Ball
- *21 3rd-4th shifter fork CP
- *22 1st-2nd shifter fork CP
- 23 Straight pin
- 24 Reverse fork rod
- *25 5th shifter fork CP
- 26 Interlock plunger
- 27 3rd-4th fork rod
- 28 1st-2nd fork rod
- 29 Ball
- 30 Checking ball spring
- 31 Gasket
- 32 Checking ball plug

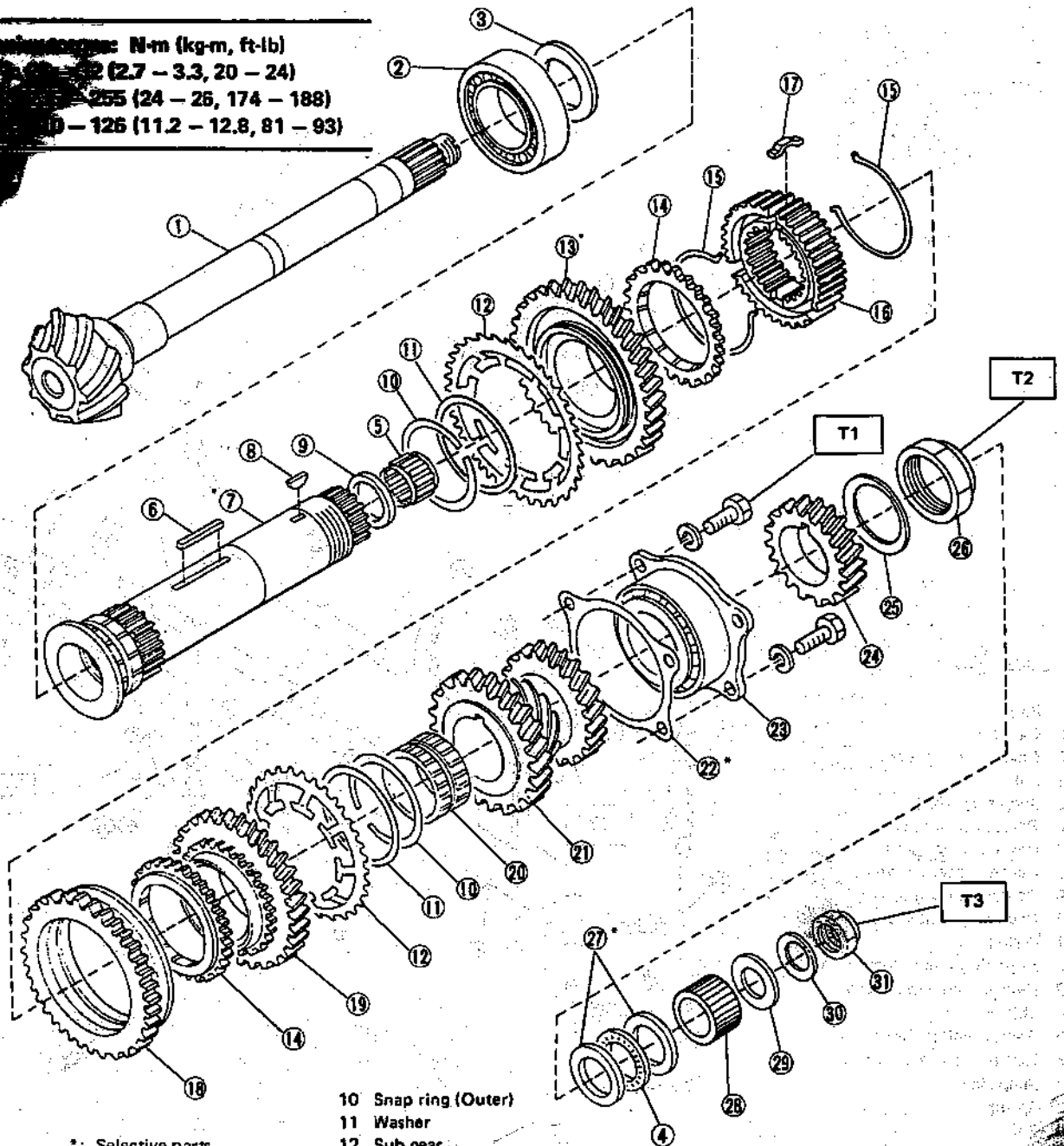
Model	Part No.	Quantity
1991-1992 - 5c	1991-1992 - 5c	1
1993-1994 - 5c	1993-1994 - 5c	1
1995-1996 - 5c	1995-1996 - 5c	1
1997-1998 - 5c	1997-1998 - 5c	1
1999-2000 - 5c	1999-2000 - 5c	1

Tightening torque: N·m (kg·m, ft·lb)
T1: 9 - 11 (0.9 - 1.1, 6.5 - 8.0)
T2: 6 - 7 (0.6 - 0.7, 4.3 - 5.1)
T3: 18.1 - 21.1 (1.85 - 2.15, 13.4 - 15.6)

Fig. 18

7. Drive Pinion ASSY (Full-time 4WD)

Tightening torque: N·m (kg·m, ft·lb)
 27 - 32 (2.7 - 3.3, 20 - 24)
 255 (24 - 26, 174 - 188)
 10 - 126 (11.2 - 12.8, 81 - 93)



*: Selective parts

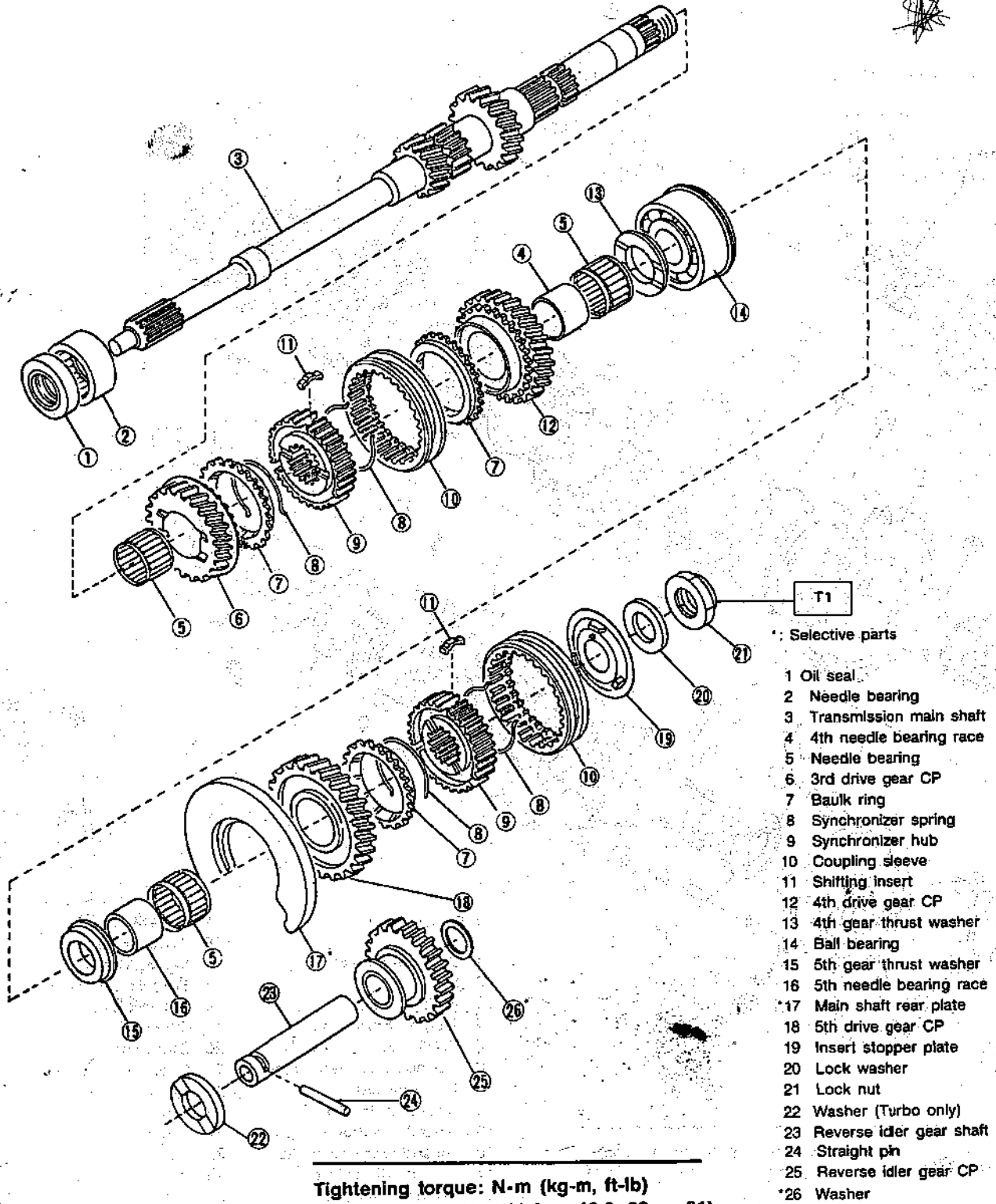
- 1 Drive pinion shaft
- 2 Roller bearing
- 3 Washer
- 4 Thrust bearing
- 5 Needle bearing
- 6 Key
- 7 Driven shaft
- 8 Woodruff key
- 9 Drive pinion collar

- 10 Snap ring (Outer)
- 11 Washer
- 12 Sub gear
- *13 1st driven gear
- 14 Baulk ring
- 15 Spring
- 16 1st-2nd synchronizer hub
- 17 Insert
- 18 Reverse driven gear
- 19 2nd driven gear
- 20 2nd driven gear bush
- 21 3rd-4th driven gear
- *22 Drive pinion shim

- 23 Roller bearing
- 24 5th driven gear
- 25 Lock washer
- 26 Lock nut
- *27 Washer
- 28 Differential bevel gear sleeve
- 29 Washer
- 30 Lock washer
- 31 Lock nut

Fig. 20

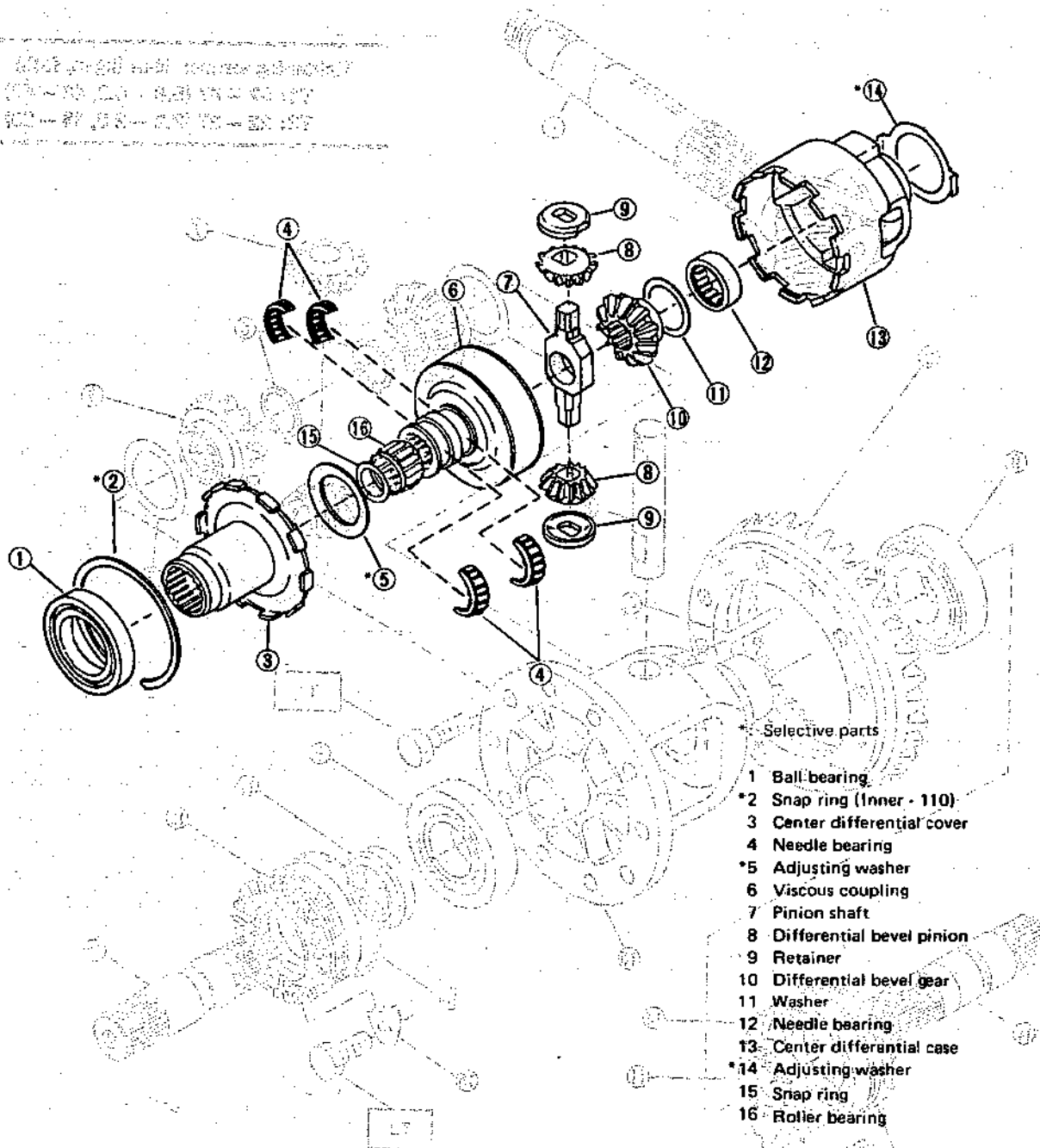
11. Main Shaft ASSY (4WD Single-range and 2000•2200cc FWD)



Tightening torque: N·m (kg·m, ft·lb)
T1: 112 — 124 (11.4 — 12.6, 82 — 91)

Fig. 24

14. Center Differential

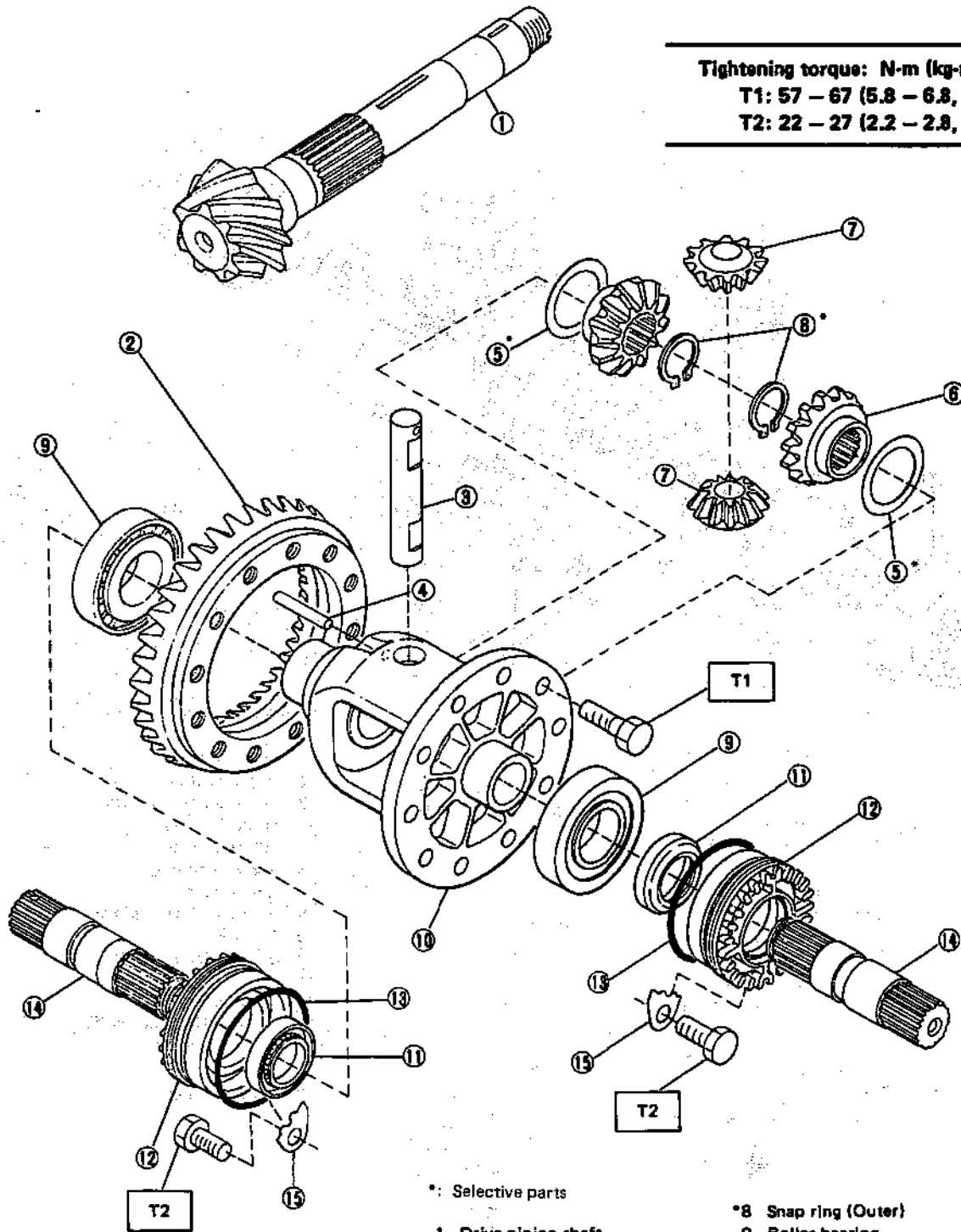


- Selective parts
- 1 Ball bearing
 - *2 Snap ring (Inner - 110)
 - 3 Center differential cover
 - 4 Needle bearing
 - *5 Adjusting washer
 - 6 Viscous coupling
 - 7 Pinion shaft
 - 8 Differential bevel pinion
 - 9 Retainer
 - 10 Differential bevel gear
 - 11 Washer
 - 12 Needle bearing
 - 13 Center differential case
 - *14 Adjusting washer
 - 15 Snap ring
 - 16 Roller bearing

Fig. 27

B3-906

15. Front Differential



Tightening torque: N·m (kg·m, ft·lb)
T1: 57 – 67 (5.8 – 6.8, 42 – 49)
T2: 22 – 27 (2.2 – 2.8, 16 – 20)

*: Selective parts

- | | |
|-----------------------------|-------------------------------|
| 1 Drive pinion shaft | *8 Snap ring (Outer) |
| 2 Hypoid driven gear | 9 Roller bearing |
| 3 Pinion shaft | 10 Differential case |
| 4 Straight pin | 11 Oil seal |
| *5 Washer | 12 Differential side retainer |
| 6 Differential bevel gear | 13 O-ring |
| 7 Differential bevel pinion | 14 Axle drive shaft |
| | 15 Retainer lock plate |

Fig. 28

W SERVICE PROCEDURE

1. General

A: APPLICATION

The table below shows the titles of the main sections in Service Procedures and the applicable vehicle models. Carry out service operations by referring to the sections applicable to the vehicle to be serviced.

Large title	Model	4WD				FWD	
		Full-time		Selective		2000cc 2200cc	1600cc 1800cc
		Single-range	Dual-range	Single-range	Dual-range		
1	General	○	○	○	○	○	○
2	Transfer Case and Extension (Full-time 4WD)	○	○				
3	Transfer Case and Extension (Selective 4WD)			○	○		
4	Rear Case (FWD)					○	○
5	Transmission Case (4WD Single-range and 2000*2200cc FWD)	○		○		○	
6	Transmission Case (4WD Dual-range)		○		○		
7	Transmission Case (1600*1800cc FWD)						○
8	Drive Pinion ASSY (Full-time 4WD)	○	○				
9	Drive Pinion ASSY (Selective 4WD)			○	○		
10	Drive Pinion ASSY (2000*2200cc FWD)					○	
11	Drive Pinion ASSY (1600*1800cc FWD)						○
12	Input Shaft ASSY (4WD Dual-range)		○		○		
13	Main Shaft ASSY (4WD Dual-range)		○		○		
14	Main Shaft ASSY (4WD Single-range and 2000*2200cc FWD)	○		○		○	
15	Main Shaft ASSY (1600*1800cc FWD)						○
16	Center Differential (Full-time 4WD)	○	○				
17	Front Differential	○	○	○	○	○	○

S/r: Single-range
D/r: Dual-range

B: PRECAUTIONS

1) The following job should be followed before disassembly:

- Clean oil, grease, dirt and dust from transmission.
- Remove drain plug to drain oil. After draining, retighten it as before.

Replace gasket with a new one.

Tightening torque:

41 — 47 N·m (4.2 — 4.8 kg·m, 30 — 35 ft·lb)

• Attach transmission to TRANSMISSION STAND SET.

Special tool:

TRANSMISSION STAND SET (499937100)

- Rotating parts should be coated with oil prior to assembly.
- All disassembled parts, if to be reused, should be reinstalled in the original positions and directions.
- Gaskets and lock washers must be replaced with new ones.
- Liquid gasket should be used where specified to prevent leakage.

C: INSPECTION

Disassembled parts should be washed clean first and then inspected carefully.

1) Bearings

Replace bearings in the following cases:

- Bearings whose balls, outer races and inner races are broken or rusty.
- Worn bearings.
- Bearings that fail to turn smoothly or make abnormal noise when turned after gear oil lubrication.

The ball bearing on the rear side of the drive pinion shaft should be checked for smooth rotation before the drive pinion ASSY is disassembled. In this case, because a preload is working on the bearing, its rotation feels slightly dragging unlike the other bearings.

- Bearings having other defects.

2) Bushing (each gear)

Replace the bushing in the following cases:

- When the sliding surface is damaged or abnormally worn.
- When the inner wall is abnormally worn.

3) Gears

- Replace gears with new ones if their tooth surfaces are broken, damaged, or excessively worn.
- Correct or replace if the cone that contacts the balk ring is rough or damaged.

(3) Correct or replace if the inner surface or end face is damaged.

4) Balk ring

Replace the ring in the following cases:

- When the inner surface and end face are damaged.
- When the ring inner surface is abnormally or partially worn down.
- If the gap between the end faces of the ring and the gear splined part is excessively small when the ring is pressed against the cone.
- When the contact surface of the synchronizer insert is scored or abnormally worn down.

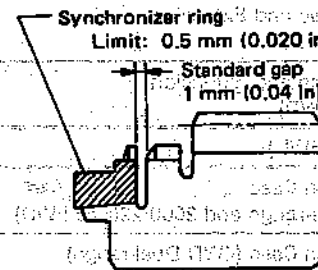


Fig. 29

5) Insert (shifting)

Replace the insert if deformed, excessively worn, or defective in any way.

6) Oil seal

Replace the oil seal if the lip is deformed, hardened, damaged, worn, or defective in any way.

7) O-ring

Replace the O-ring if the sealing face is deformed, hardened, damaged, worn, or defective in any way.

8) Gearshift mechanism

Repair or replace the gearshift mechanism if excessively worn, bent, or defective in any way.

9) Differential gear

Repair or replace the differential gear in the following cases.

- The hypoid drive gear and drive pinion shaft tooth surface are damaged, excessively worn, or seized.
- The roller bearing on the drive pinion shaft has a worn or damaged roller path.
- There is damage, wear, or seizure of the differential bevel pinion, differential bevel gear, washer, pinion shaft, and straight pin.
- The differential case has worn or damaged sliding surfaces.

2. Transfer Case and Extension (Full-time 4WD)

A: REMOVAL

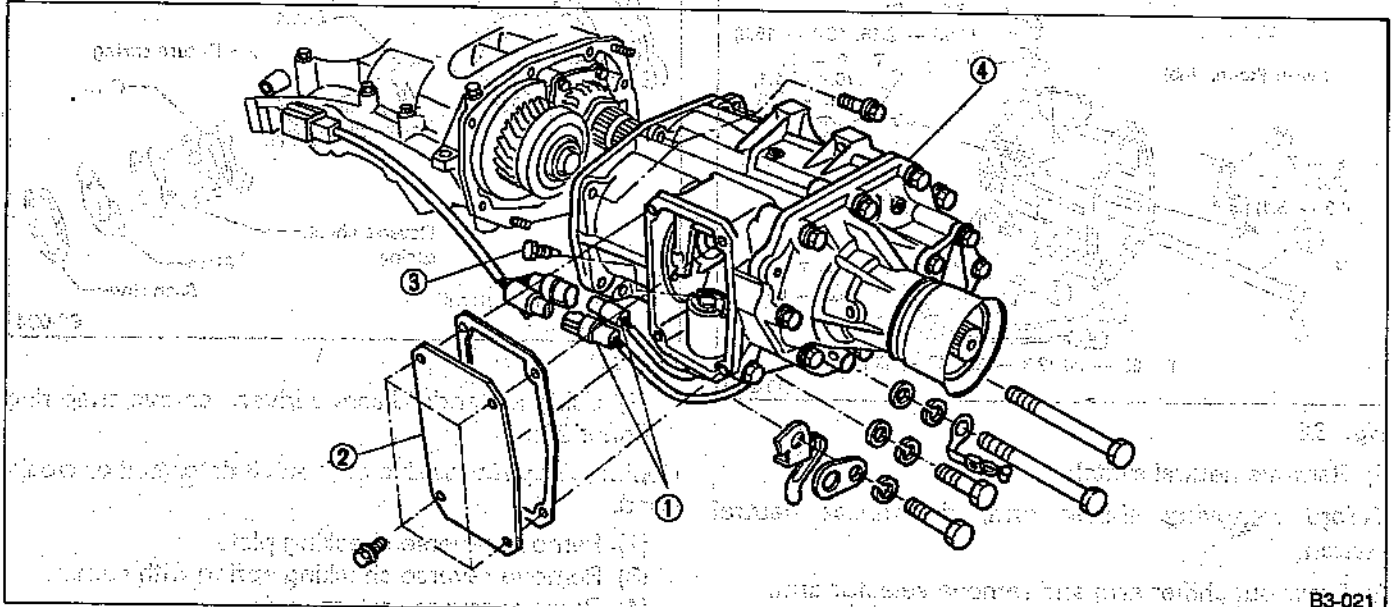


Fig. 30

B3-021

- 1) Disconnect each connector of transmission cord.
- 2) Remove transfer cover.
- 3) Remove shifter fork screw which secures selector arm to shifter arm.
Remove transfer case with extension ASSY.

B: DISASSEMBLY

1. SEPARATION OF TRANSFER CASE AND EXTENSION ASSY

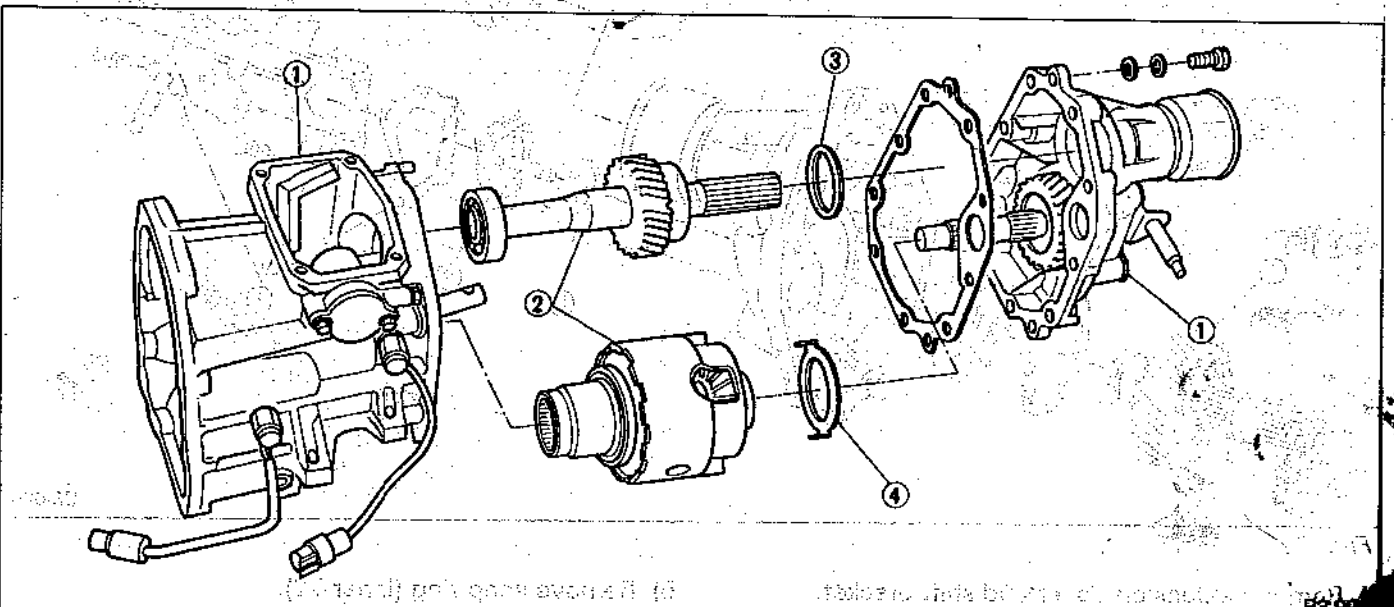


Fig. 31

B3-

- 1) Separate transfer case and extension ASSY.
- 2) Remove transfer driven shaft and center differential as a set.

- 3) Remove thrust washer (52 x 61 x t).
- 4) Remove center differential washer.

2. TRANSFER CASE

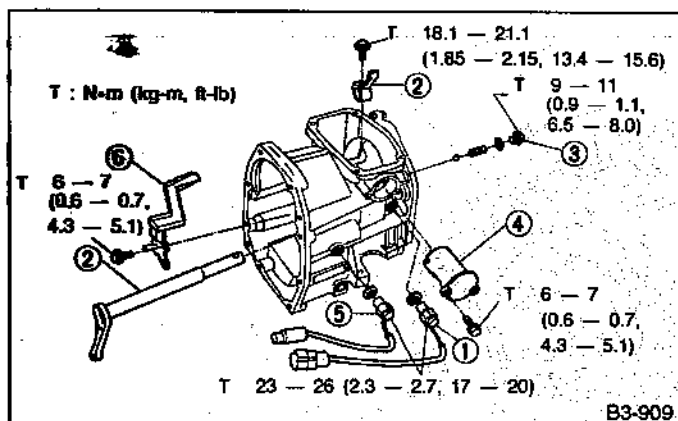


Fig. 32

- 1) Remove neutral switch.
- Before removing shifter arm, disconnect neutral switch.
- 2) Draw out shifter arm and remove selector arm.
 - 3) Remove plug, spring and reverse check ball.

3. EXTENSION

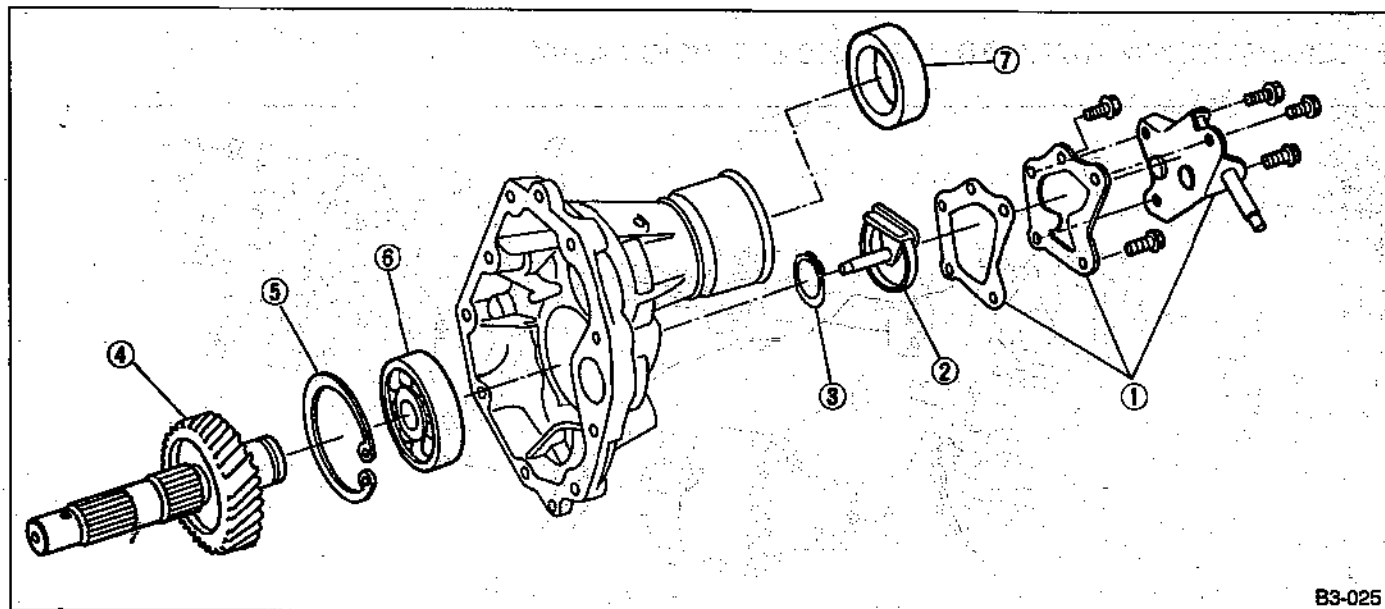


Fig. 34

- 1) Remove extension cover and shift bracket.
 - 2) Remove oil guide.
 - 3) Remove snap ring (Outer-30).
 - 4) Remove transfer drive shaft.
 - 5) Remove snap ring (Inner-72).
 - 6) Removal of ball bearing.
 - 7) Removal of oil seal.
- Do not remove ball bearing unless replacing.**
Do not reuse oil seal.

- 4) Remove reverse checking sleeve.
- Disassembly procedure is as follows:

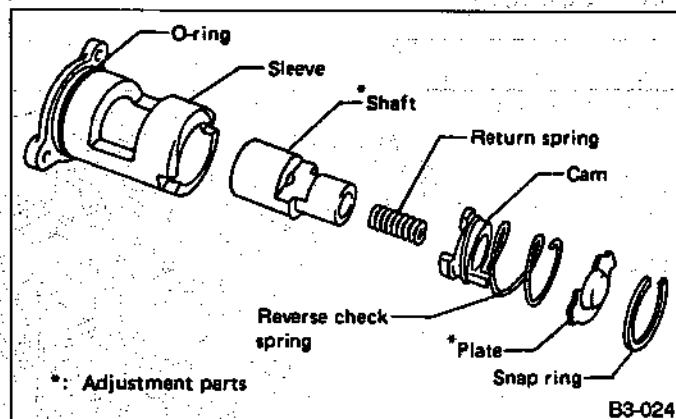


Fig. 33

- (1) Using a standard screwdriver, remove snap ring (inner 28).

Replace snap ring with a new one if deformed or weakened.

- (2) Remove reverse checking plate.
- (3) Remove reverse checking spring with cam.
- (4) Remove reverse return spring.
- (5) Remove reverse accent shaft.
- (6) Remove O-ring.
- 5) Remove back-up light switch.
- 6) Remove oil guide.

C: ASSEMBLY

1. EXTENSION

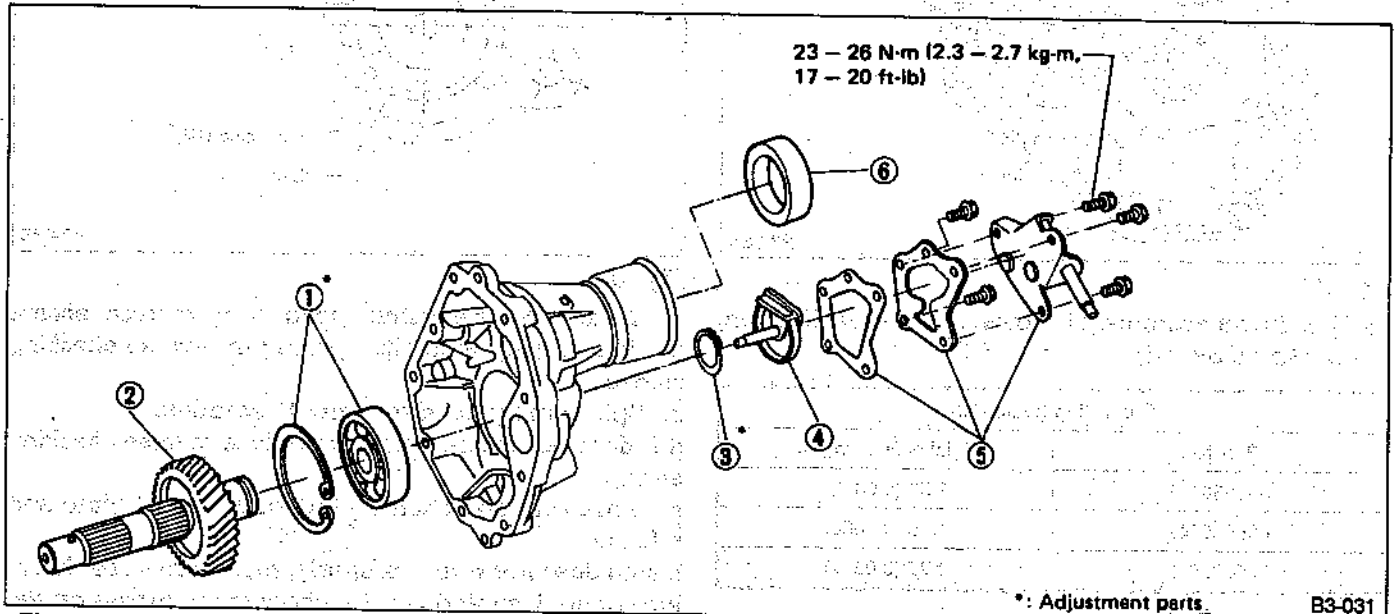


Fig. 35

1) Installation of ball bearing and selection of snap ring (Inner-72).

(1) Attach ball bearing (30 x 72 x 17) to extension and install snap ring.

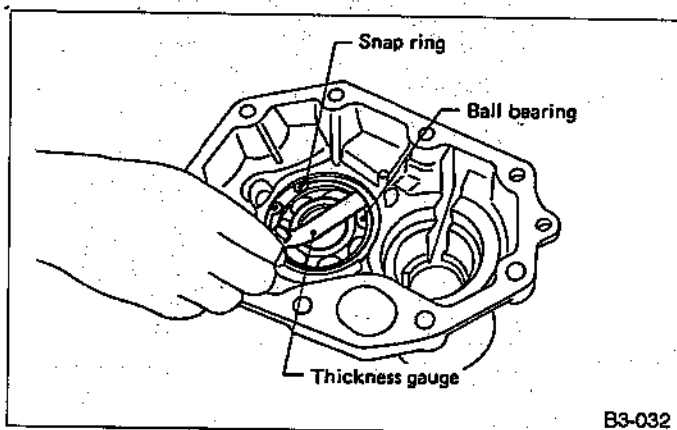
(2) Measure clearance between snap ring and outer race of ball bearing.

Replace ball bearing with a new one.

Clearance: 0 — 0.15 mm (0 — 0.0059 in)

(3) If the measurement is not within the specification, select suitable snap ring.

Snap Ring (Inner-72)	
Part No.	Thickness mm (in)
805172071	1.78 (0.0701)
805172072	1.90 (0.0748)
805172073	2.02 (0.0795)



B3-032

Fig. 36

2) Installation of transfer drive shaft.

Press transfer drive shaft into inner race of ball bearing.

3) Selection of snap ring (Outer-30).

(1) Install snap ring on transfer drive shaft.

(2) Measure clearance between snap ring and inner race of ball bearing.

Clearance:
0 — 0.15 mm (0 — 0.0059 in)

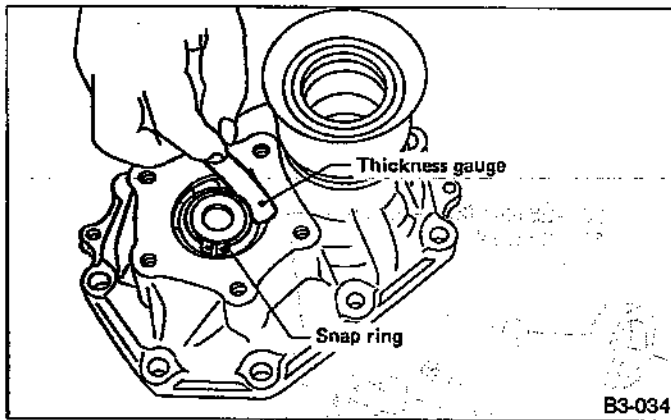


Fig. 37

(3) If the measurement is not within the specification, select suitable ring.

Snap Ring (Outer-30)	
Part No.	Thickness mm (in)
805030041	1.53 (0.0602)
805030042	1.65 (0.0650)
805030043	1.77 (0.0697)

4) Install oil guide.

The oil guide must be installed correctly. Before installing it, check to ensure that it stops at the correct portion of the extension cover.

5) Install extension cover and shift bracket.

Use new gasket

6) Install oil seal.

Use new oil seal.

2. TRANSFER CASE

Assembly of transfer case is in the reverse order to disassembly. Observe the following.

1) Assembly of reverse checking sleeve.

(1) Install reverse accent shaft, checking cam, return spring and checking spring onto reverse checking sleeve.

Be sure the bent section of reverse checking spring is positioned in the groove in checking cam.

(2) Hook the bent section of reverse checking spring over reverse check plate.

(3) Rotate cam so that the protrusion of reverse checking cam is at the opening in plate.

(4) With cam held in that position, install plate onto reverse checking sleeve and hold with snap ring (Inner-28).

(5) Position O-ring (35.4 x 1.5) in groove in sleeve.

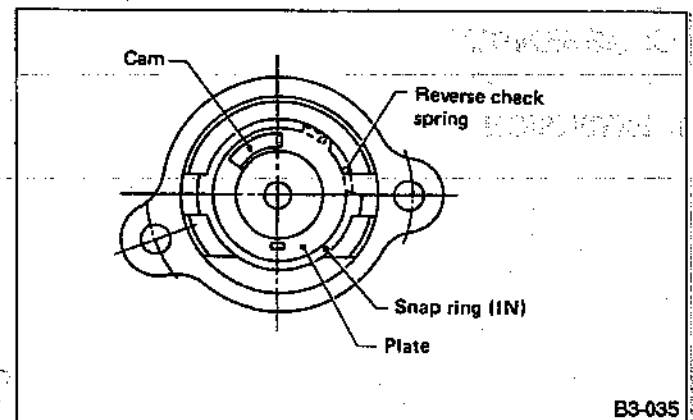


Fig. 38

a. Make sure the cutout section of reverse accent shaft is aligned with the opening in reverse checking sleeve.

b. Spin cam by hand for smooth rotation.

If it does not return properly, replace reverse checking spring.

c. Move cam and shaft all the way toward plate and release.

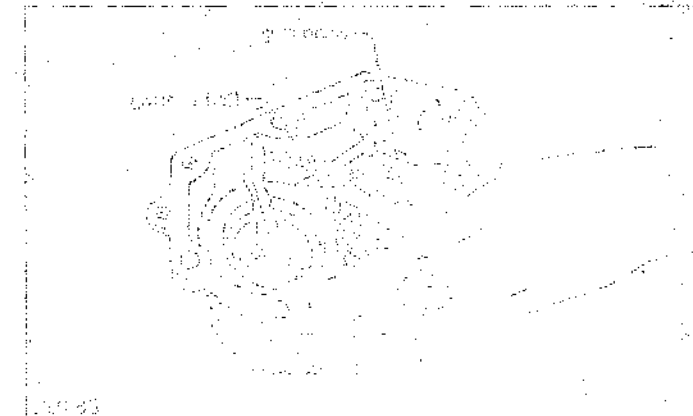
If cam does not return properly, replace reverse checking spring; if shaft does not, check for scratches on the inner surface of sleeve. If sleeve is in good order, replace spring.

d. Select a suitable reverse accent shaft and reverse check plate by referring to "Neutral Position Adjustment."

2) Installation of shifter arm and selector arm.

Install shifter arm into the partition from the front while inserting selector arm into the opening in reverse checking sleeve. Pass shaft through hole in selector arm until its end comes out of the rear of transfer case.

Apply a coat of gear oil to shifter arm CP. Also make sure oil seal is positioned properly.



3. COMBINATION OF TRANSFER CASE AND EXTENSION ASSY

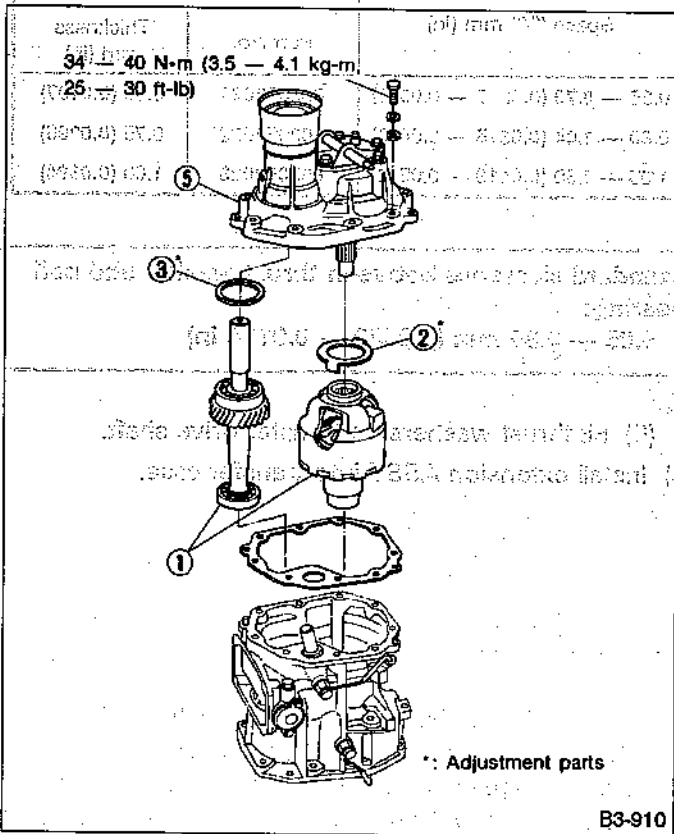


Fig. 39

- 1) Install center differential and transfer drive shaft into transfer casing.
- 2) Selection of center differential washer.
 - (1) Measure height "A" as shown in figure.

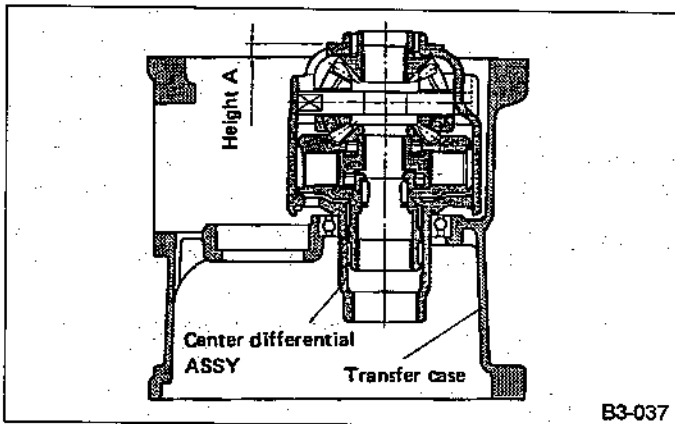


Fig. 40

- (2) Measure depth "B" as shown in figure.

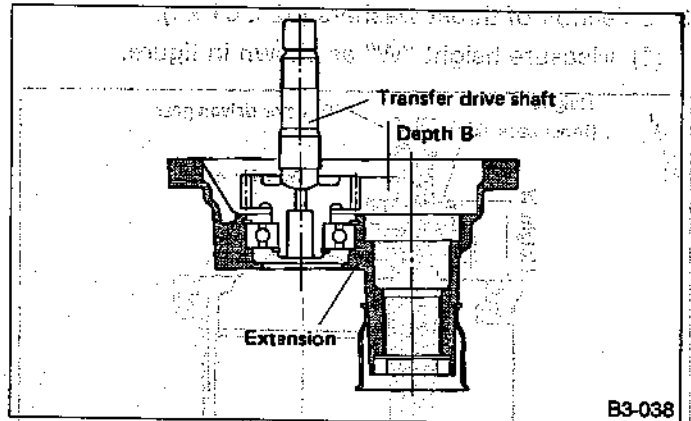


Fig. 41

(3) Calculate space "C" using the following equation:
 $C = B - A + 0.24 \text{ mm (0.0094 in)}$ [Thickness of gasket]

(4) Select suitable washer in the following table.

Space "C" mm (in)	Center differential washer	
	Part No.	Thickness mm (in)
1.60 — 1.74 (0.0630 — 0.0685)	38965AA080	1.25 (0.0492)
1.75 — 1.89 (0.0689 — 0.0744)	38965AA090	1.40 (0.0551)
1.90 — 2.04 (0.0748 — 0.0803)	38965AA100	1.55 (0.0610)
2.05 — 2.19 (0.0807 — 0.0862)	38965AA110	1.70 (0.0669)
2.20 — 2.40 (0.0866 — 0.0945)	38965AA120	1.85 (0.0728)

Standard clearance between center differential washer and thrust bearing:

0.35 — 0.55 mm (0.0138 — 0.0217 in)

(5) Install center differential washer on center differential as shown in figure.

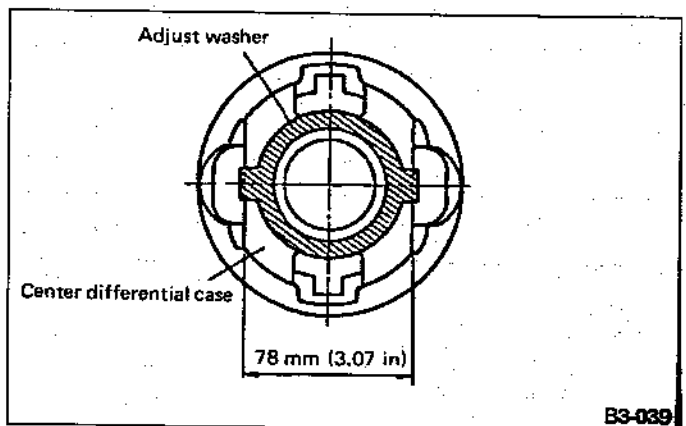


Fig. 42

3) Selection of thrust washers (52 x 61 x t).

- (1) Measure height "W" as shown in figure.

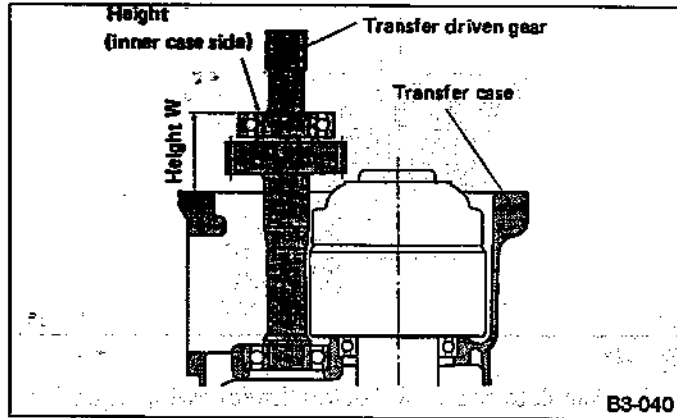


Fig. 43

- (2) Measure depth "X" as shown in figure.

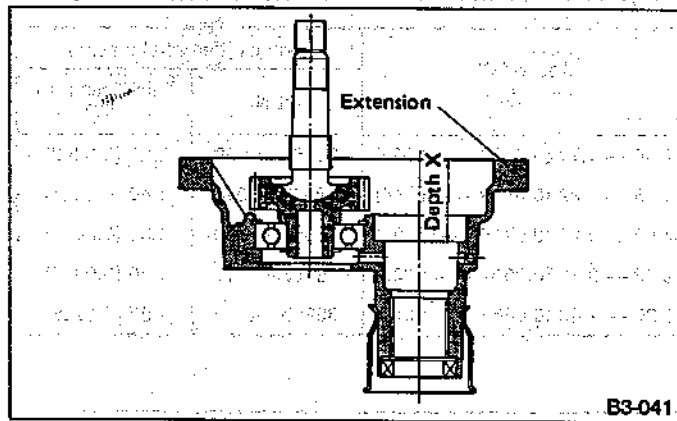


Fig. 44

- (3) Calculate space "Y" using the following equation:
-
- $$Y = X - W + 0.24 \text{ mm (0.0094 in) [Thickness of jacket]}$$

- (4) Select suitable washer in the following table.

Space "Y" mm (in)	Thrust washer (52 x 61 x t)	
	Part No.	Thickness mm (in)
0.55 — 0.79 (0.0217 — 0.0311)	803052021	0.50 (0.0197)
0.80 — 1.04 (0.0315 — 0.0409)	803052022	0.75 (0.0295)
1.05 — 1.30 (0.0413 — 0.0512)	803052023	1.00 (0.0394)

Standard clearance between thrust washer and ball bearing:

0.05 — 0.30 mm (0.0020 — 0.0118 in)

- (5) Fit thrust washers on transfer drive shaft.
 4) Install extension ASSY into transfer case.

D: INSTALLATION

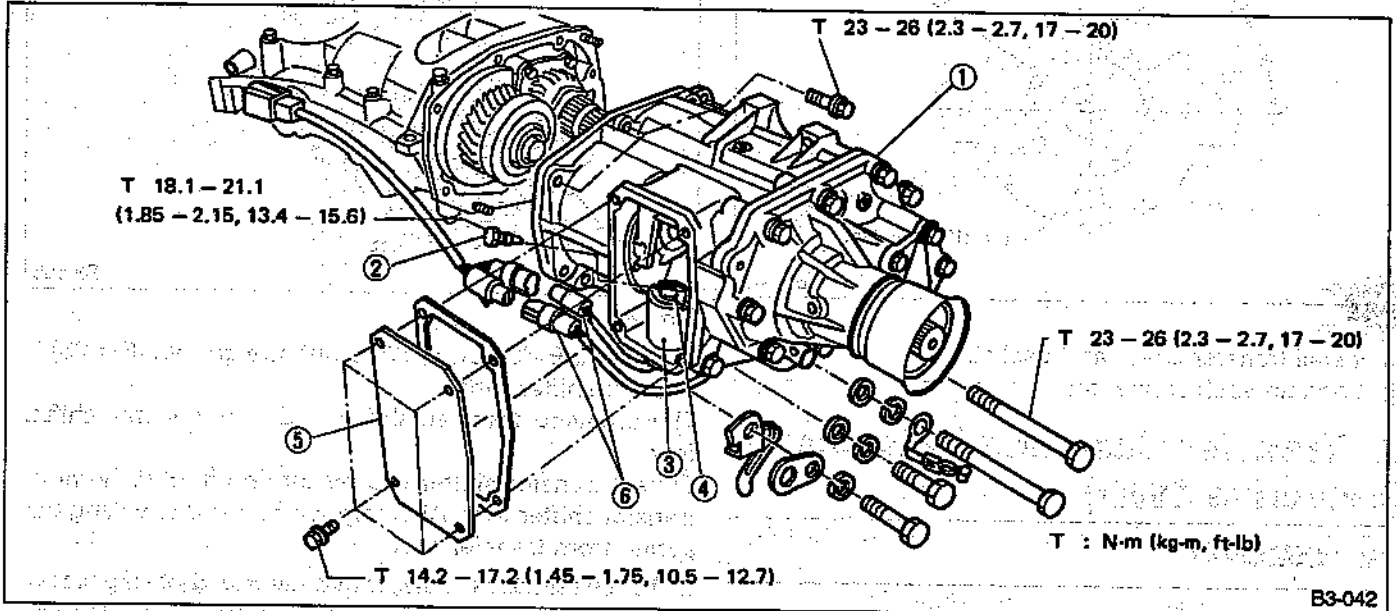


Fig. 45

- 1) Install transfer case with extension ASSY.
- 2) Secure selector arm to shifter arm CP with shifter fork screw. Shifter arm CP should be caught by pawl of rod. Selector arm must be engaged with reverse check sleeve ASSY.
- 3) Adjustment of neutral position.
 - (1) Shift gear into 3rd gear position.
 - (2) Shifter arm turns lightly toward the 1st/2nd gear side but heavily toward the reverse gear side because of the function of the return spring, until arm contacts the stopper.
 - (3) Make adjustment so that the heavy stroke (reverse side) is a little more than the light stroke (1st/2nd side).
 - (4) To adjust, remove bolts holding reverse check sleeve ASSY to the case, move sleeve ASSY outward, and place adjustment shim (0 to 1 ea.) between sleeve ASSY and case to adjust the clearance.

Be careful not to break O-ring when placing shim(s).

Adjustment shim	
Part No.	Thickness mm (in)
32190AA000	0.15 (0.0059)
32190AA010	0.30 (0.0118)

- When shim is removed, the neutral position will move closer to reverse; when shim is added, the neutral position will move closer to 1st gear.
- If shims alone cannot adjust the clearance, replace reverse accent shaft and re-adjust.

Reverse accent shaft

Part No.	Mark	Remarks
32188AA020	A	Neutral position is closer to 1st gear.
32188AA002	No mark or B	Standard
32188AA030	C	Neutral position is closer to reverse gear.

- 4) Reverse check plate adjustment. Shift shifter arm CP to "5th" and then to reverse to see if reverse check mechanism operates properly. Also check to see if arm returns to Neutral when released from the reverse position. If arm does not return properly, replace reverse check plate.

Reverse check plate			
Part No.	No.	Angle θ	Remarks
32189AA000	0	28°	Arm stops closer to "5th".
32189AA010	1	31°	Arm stops closer to "5th".
32189AA020	2	34°	Standard
32189AA030	3	37°	Arm stops closer to reverse.
32189AA040	4	40°	Arm stops closer to reverse.

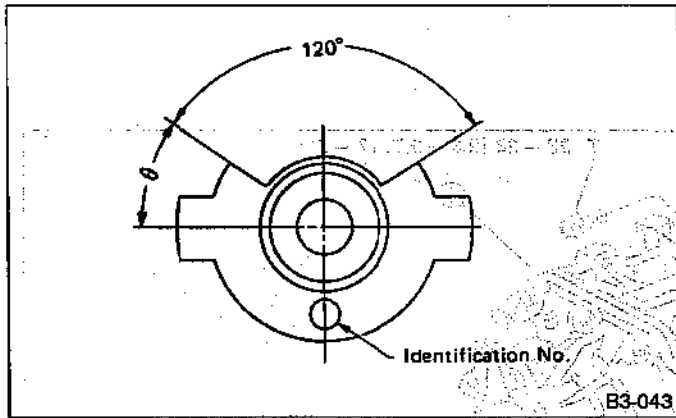


Fig. 46

- 5) Install transfer cover and gasket.
- 6) Connect each connector.

3. Transfer Case and Extension (Selective 4WD)

A: REMOVAL

1) Removing actuator & cable ASSY

- (1) Disconnect connectors of transmission cord.
- (2) Using REMOVER II, drive out spring pin (5.2 x 28) connecting transfer shifter shaft and transfer shifter lever on the right side of transfer case.

Special tool:

REMOVER II (398791600)

- (3) Remove transfer shifter lever from transfer shifter shaft.
- (4) Remove snap pin and extract 8-mm clevis pin. Then, remove cable from transfer shifter lever.
- (5) Remove five 8-mm bolts & washers (three on actuator and two on cable) and remove actuator & cable ASSY.

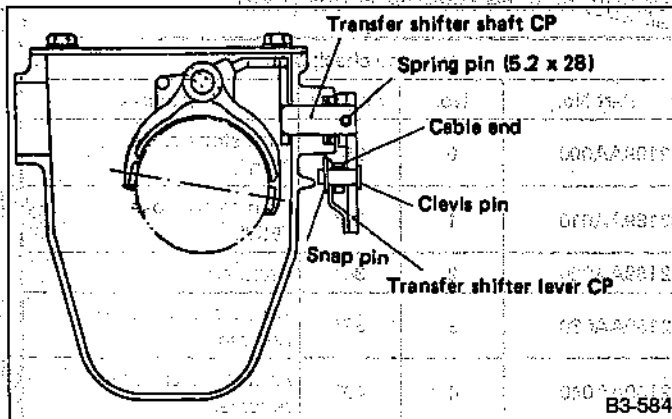


Fig. 47

- 2) Remove transfer cover by loosening four bolts.

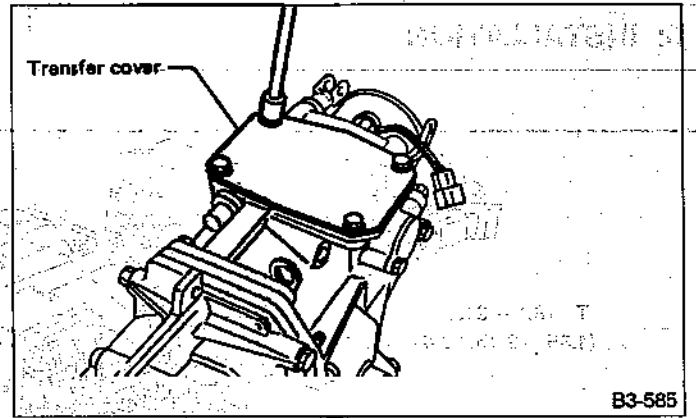


Fig. 48

- 3) Using REMOVER II, drive out straight pin (5 x 25) in transfer shifter fork.
- 4) Removing transfer shifter rod and transfer shifter fork

Extract transfer shifter rod by turning it 180°. Remove transfer shifter fork. Also remove ball and checking ball spring from transfer case.

- a. When taking out fork, move reverse checking sleeve 2 to 3 mm (0.08 to 0.12 in) toward outside by loosening it.
- b. Be careful not to drop ball when removing transfer shifter rod.

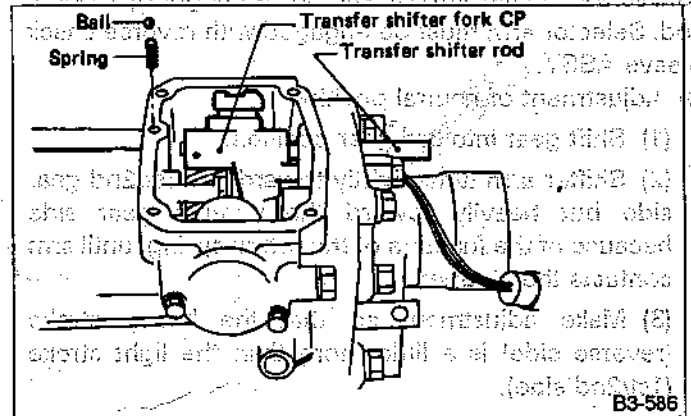
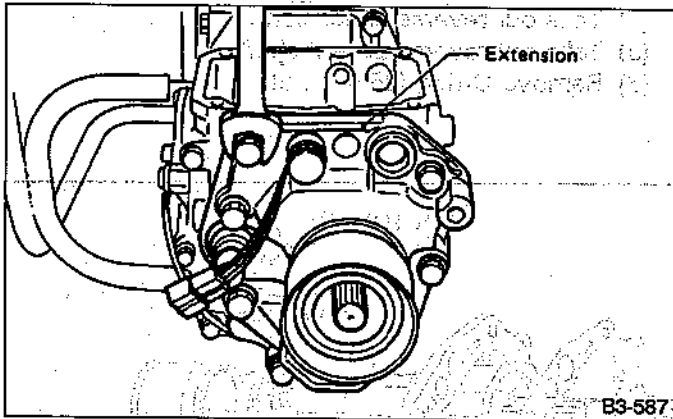


Fig. 49

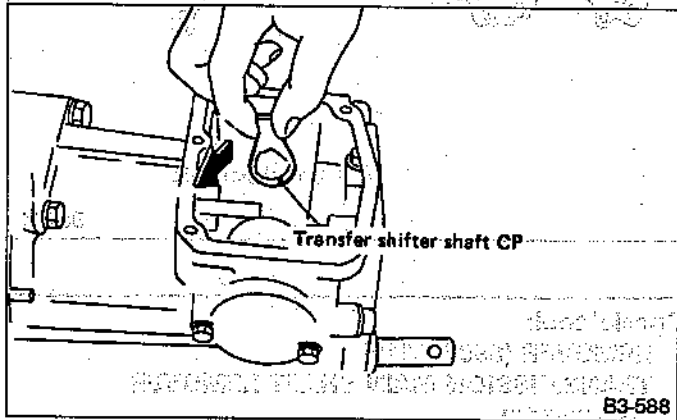
- 5) Remove the seven bolts from extension, and remove extension & transfer gear ASSY.



B3-587

Fig. 50

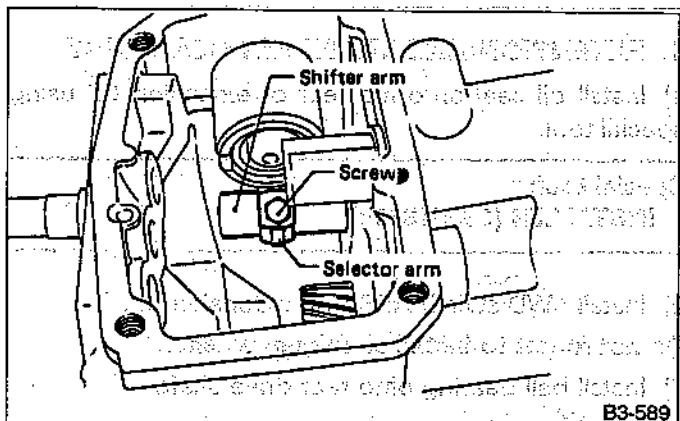
6) Extract transfer shifter shaft from the right side of transfer case.



B3-588

Fig. 51

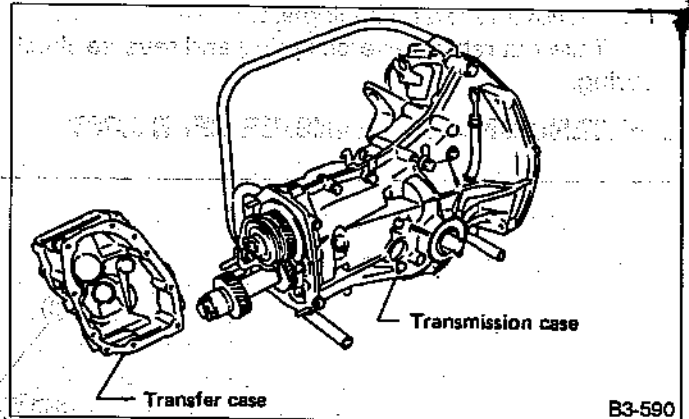
- 7) Remove transfer case plug with gasket and then remove reverse accent spring and ball (7.1438).
- 8) Remove the two bolts from reverse check sleeve ASSY and move the sleeve ASSY until it rotates freely.
- 9) Remove shifter fork screw securing selector arm to shifter arm CP.



B3-589

Fig. 52

10) Loosen eight bolts, and remove transfer case and shifter ASSY from transmission case by tapping with a plastic hammer.



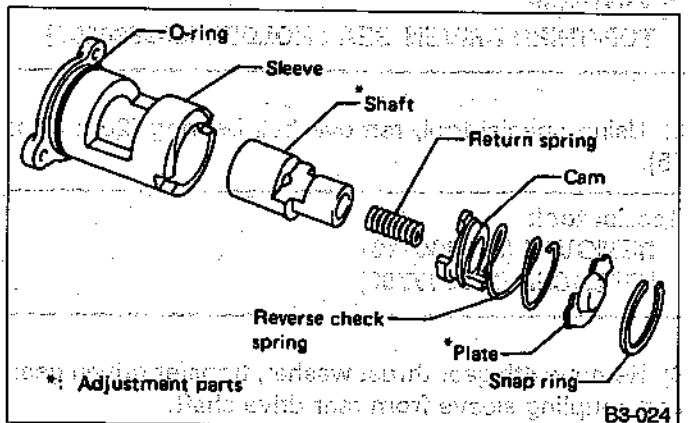
B3-590

Fig. 53

B: DISASSEMBLY

1. TRANSFER CASE

- 1) Pull out shifter arm CP and selector arm from transfer case.
- 2) Remove oil guide from transfer case.
- 3) Remove back-up light switch ASSY and neutral switch ASSY.
 - a. Some models are not equipped with neutral switch ASSY.
 - b. Replace aluminum gasket with a new one.
- 4) Remove reverse check sleeve ASSY by loosening 6-mm bolt and washer ASSY in two places.
 - a. Be careful not to damage O-ring fitted in reverse check sleeve.
 - b. 0 to 3 shim(s) are inserted between reverse check sleeve and transfer case. Be careful not to break them.
- 5) Disassembling reverse check sleeve ASSY.



B3-024

Fig. 54

(1) Using a standard screwdriver, remove snap ring (inner 28).

Replace snap ring with a new one if deformed or worn.

- (2) Remove reverse check plate.
- (3) Take out return reverse spring and reverse check spring.

- (4) Take out reverse check cam.
- (5) Take out reverse accent shaft.
- (6) Remove O-ring (35.4 x 1.5).

2. EXTENSION AND TRANSFER GEAR ASSY

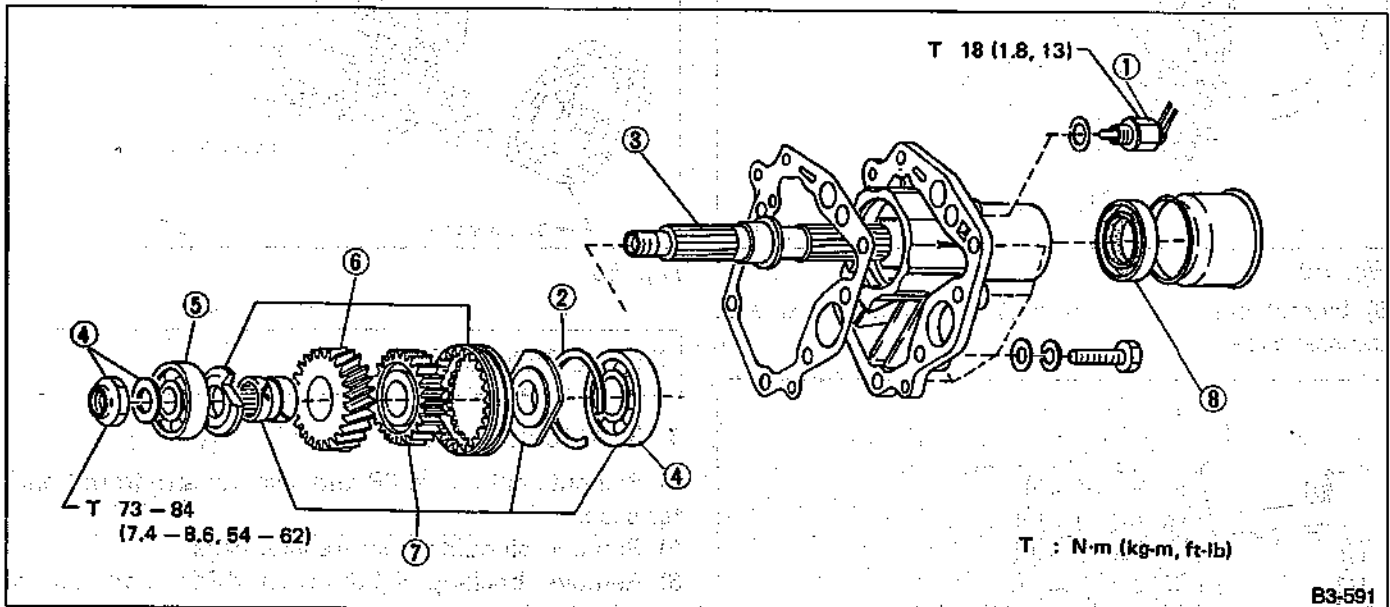


Fig. 55

- 1) Remove 4WD switch ASSY.
Replace aluminum gasket with a new one.
- 2) Using a snap-ring pliers, remove snap ring (Inner-68) from extension.
- 3) Remove rear drive shaft by tapping from the rear with an aluminum bar.
- 4) Put sleeve coupling in drive position, and remove locknut (18 x 10.5) with special tool.

Remove caulking before taking off locknut.

Special tool:

TOP-THIRD DRIVEN GEAR HOLDER (899884100)

- 5) Using special tool, remove ball bearing (20 x 52 x 15).

Special tool:

**REMOVER (899864110)
REPLACER (398517700)**

- 6) Remove 4th gear thrust washer, transfer driven gear and coupling sleeve from rear drive shaft.
- 7) Using special tool, remove following parts from rear drive shaft.
 - Rear shaft driven bushing
 - Transfer synchronizer hub
 - Rear drive spacer
 - Ball bearing (28 x 68 x 18)

Special tool:

**REMOVER (899714110)
TRANSMISSION MAIN SHAFT REMOVER
(899864110)**

- 8) Remove oil seal.

Do not reuse oil seal.

C: ASSEMBLY

1. EXTENSION AND TRANSFER GEAR ASSY

- 1) Install oil seal onto the rear of extension CP using special tool.

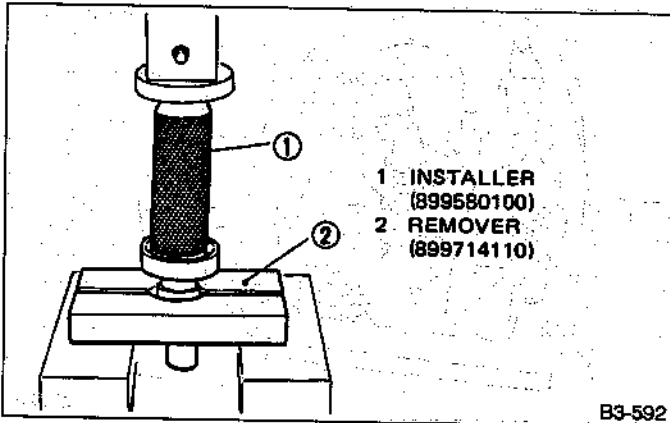
Special tool:

INSTALLER (399513600)

- 2) Install 4WD switch ASSY on extension CP.

Do not forget to install aluminum washer.

- 3) Install ball bearing onto rear drive shaft.

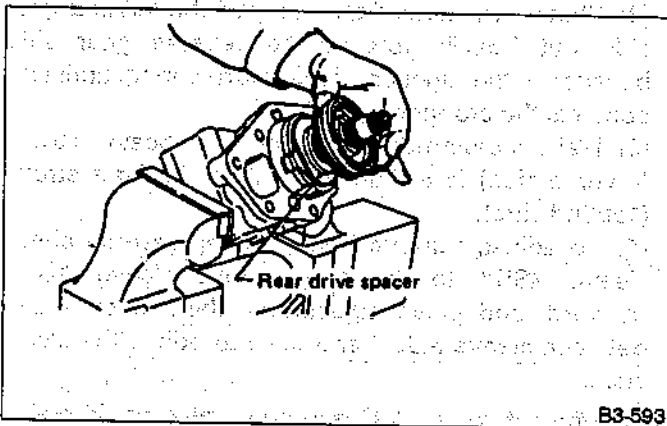


- 1 INSTALLER (899580100)
- 2 REMOVER (899714110)

B3-592

Fig. 56

4) Install rear drive spacer, synchronizer hub and sleeve onto rear drive shaft.



B3-593

Fig. 57

5) Install transfer driven gear bushing onto rear drive shaft with special tool.

- Special tool:
- INSTALLER (899874100)
 - REMOVER (899714110)

6) Install coupling sleeve, transfer driven gear and thrust washer onto rear drive shaft.
7) Install ball bearing onto rear drive shaft with special tool.

- Special tool:
- PRESS ASSY (899754110)
 - REMOVER (899714110)

8) Shift sleeve to the drive position and tighten lock nut with special tool.

Stake the lock nut at four positions after tightening.

- Special tool:
- HOLDER (899884100)
 - SOCKET WRENCH (899988608)

9) Hammer rear drive shaft into extension with a mallet hammer. And fit snap ring to the groove inside extension.

2. TRANSFER CASE

- 1) Install needle bearing race into bore in transfer case. **Be careful not to damage stopper on transfer case.**
- 2) Install back-up light switch ASSY and neutral switch ASSY on transfer case.

Tightening torque:
18 N·m (1.8 kg-m, 13 ft-lb)

a. Some models are not equipped with neutral switch ASSY.

b. Use new aluminum washer.

3) Install oil seal into bore in transfer case using OIL SEAL INSTALLER (498057000).

4) Install oil guide.

Make sure oil guide is secure and tight.

5) Assembling reverse check sleeve ASSY.

(1) Install reverse accent shaft, check cam, return spring and check spring onto reverse check sleeve.

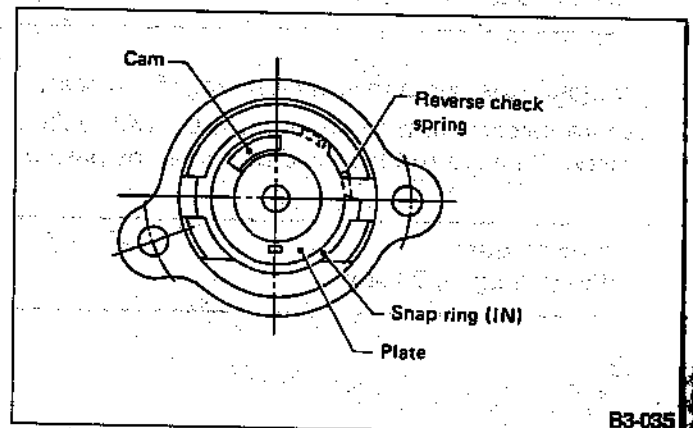
Be sure the bent section of reverse check spring is positioned in the groove in check cam.

(2) Hook the bent section of reverse check spring over reverse check plate.

(3) Rotate cam so that the protrusion of reverse check cam is at the opening in plate.

(4) With cam held in that position, install plate onto reverse check sleeve and hold with snap ring (Inner-28).

(5) Position O-ring (35.4 x 1.5) in groove in sleeve.



B3-035

Fig. 58

a. Make sure the cutout section of reverse accent shaft is aligned with the opening in reverse check sleeve.

b. Spin cam by hand for smooth rotation.

If it does not return properly, replace reverse spring.

c. Move cam and shaft all the way toward plate and release. If cam does not return properly, replace reverse check spring; if shaft does not, check for scratches on the inner surface of sleeve. If sleeve is in good order, replace spring.

d. Select a suitable reverse check plate by referring to "Neutral Position Adjustment".

6) Install reverse check sleeve ASSY onto transfer case and tighten with two bolts & washers.

Tightening torque:

10 N·m (1.0 kg-m, 7 ft-lb)

7) Install shifter arm CP into the partition from the front while inserting selector arm into the opening in sleeve ASSY. Pass shaft through hole in selector arm until its end comes out of the rear of transfer case.

Apply a coat of gear oil to shifter arm CP. Also make sure oil seal [18 x 28 x 7 mm (0.71 x 1.10 x 0.28 in)] is positioned properly.

8) Press oil seal [15 x 25 x 2 mm (0.59 x 0.98 x 0.08 in)] completely into the right boss section of transfer case.

9) Press oil seal [13 x 22 x 6 mm (0.51 x 0.87 x 0.24 in)] completely into bore for transfer shifter rod at rear of transfer case.

10) Insert transfer shifter shaft into the right side of transfer case from inside.

D: INSTALLATION

1) Secure transfer case & shifter ASSY to transmission case with eight bolts.

Tightening torque:

25 N·m (2.5 kg-m, 18 ft-lb)

Be sure gasket is positioned on the rear of the case.

2) Secure selector arm to shifter arm CP with shifter fork screw. Shifter arm CP should be caught by pawl of rod.

Tightening torque:

10 N·m (1.0 kg-m, 7 ft-lb)

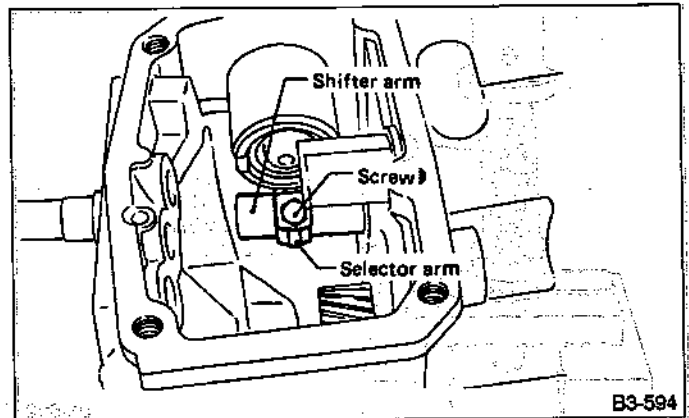


Fig. 59

3) Neutral position adjustment

- (1) Shift gear into 3rd gear position.
- (2) Shifter arm turns lightly toward the 1st/2nd-gear side but heavily toward the reverse gear side because of the function of the return spring, until arm contacts the stopper.
- (3) Make adjustment so that the heavy stroke (reverse side) is a little more than the light stroke (1st/2nd side).
- (4) To adjust, remove bolts holding reverse check sleeve ASSY to the case, move sleeve ASSY outward, and place adjustment shim (0 to 1 ea.) between sleeve ASSY and case to adjust the clearance.

Be careful not to break O-ring when placing shim(s).

Adjustment shim	
Part No.	Thickness mm (in)
32190AA000	0.15 (0.0059)
32190AA010	0.30 (0.0118)

- When shim is removed, the neutral position will move closer to reverse; when shim is added, the neutral position will move closer to 1st gear.
- If shims alone cannot adjust the clearance, replace reverse accent shaft and re-adjust.

Reverse accent shaft		
Part No.	Mark	Remarks
32188AA020	A	Neutral position is closer to 1st gear.
32188AA002	No mark	Standard
32188AA030	C	Neutral position is closer to reverse gear.

4) Reverse check plate adjustment: Shift shifter arm CP to "5th" and then to reverse to see if reverse check mechanism operate properly. Also check to see if arm returns to Neutral when released from the reverse position. If arm does not return prop

erly, replace reverse check plate.

Reverse check plate			
Part No.	No.	Angle θ	Remarks
32189AA000	0	28°	Arm stops closer to "5th".
32189AA010	1	31°	Arm stops closer to "5th".
32189AA020	2	34°	Standard
32189AA030	3	37°	Arm stops closer to reverse.
32189AA040	4	40°	Arm stops closer to reverse.

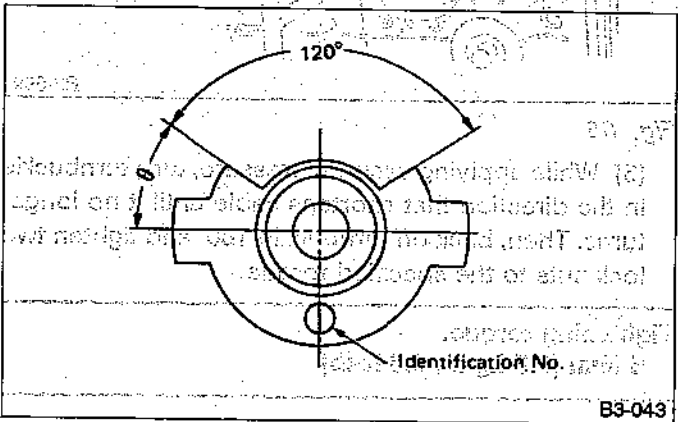


Fig. 60

5) Install ball (7.1438), reverse accent spring, aluminum gasket and plug in that order.
Use new aluminum gasket.

Tightening torque:
10 N·m (1.0 kg-m, 7 ft-lb)

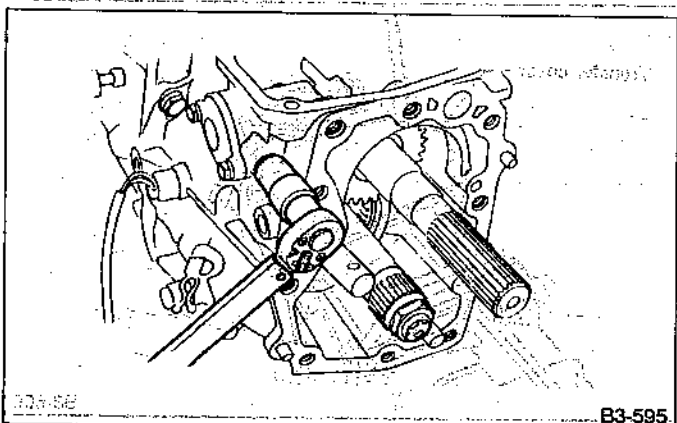


Fig. 61

6) Install extension with transfer gasket and tighten bolts.

Tightening torque:
34 — 40 N·m
(3.5 — 4.1 kg-m, 25 — 30 ft-lb)

While installing, the gears (transfer drive and driven) should engage each other.

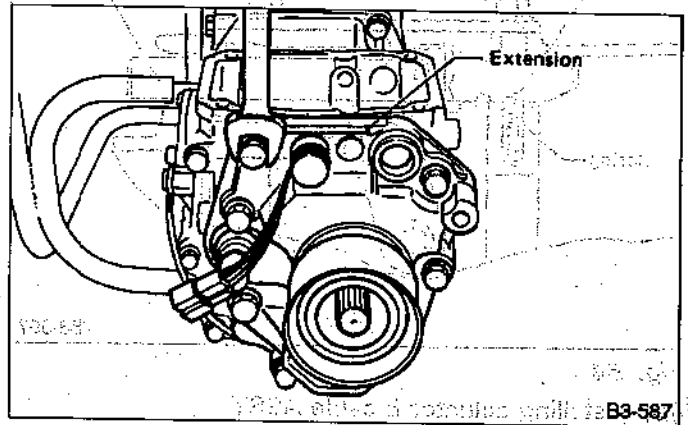


Fig. 62

7) Install transfer shifter fork to coupling sleeve and align the cutout-section of fork with arm of transfer shifter shaft.

Apply a coat of oil to nylon pawl of fork.

8) Install checking ball spring and ball (6.35) in transfer case.

Be careful not to drop ball and spring into transfer case.

9) Installing transfer shifted rod

(1) Insert transfer shifter rod into bore in the upper center of extension with the cutout section facing the front.

(2) Pass it through transfer shifter fork while positioning ball and spring in the hole at the center of transfer case.

(3) Align the hole in transfer shifter fork with that in shifter rod and drive spring pin (5 x 25) into the holes.

a. Be sure each end of spring pin protrudes slightly beyond the holes when installing.

b. Position ball with the cutout section of shifter rod facing down. Be careful not to drop the ball.

c. To avoid scratching oil seal, apply a coat of oil to shifter rod before installing.

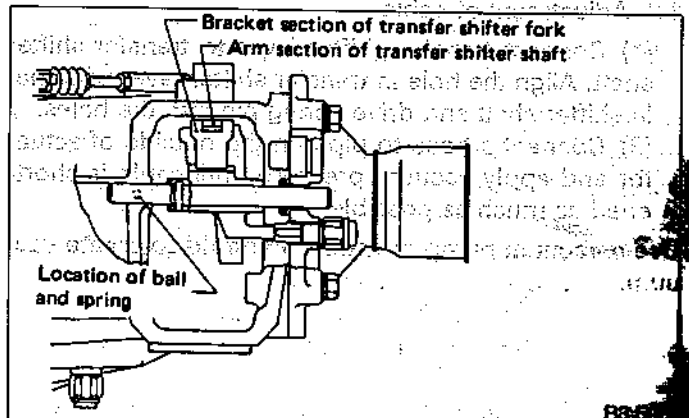


Fig. 63

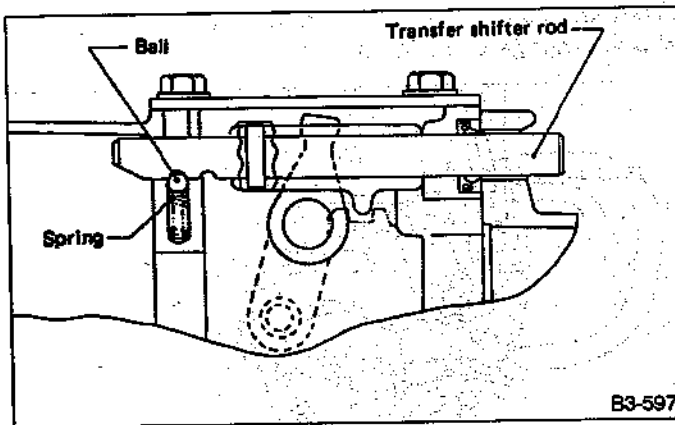


Fig. 64

10) Installing actuator & cable ASSY

- (1) Connect the end of cable and shifter lever with an 8-mm clevis pin and secure with a snap pin.

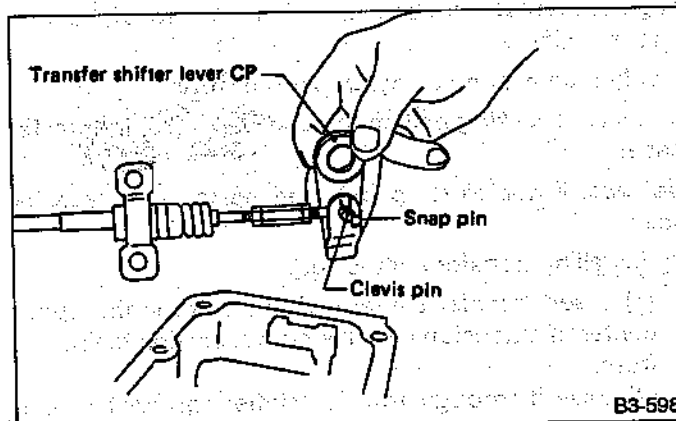


Fig. 65

- (2) Secure actuator to the left side of transmission case with three 8-mm bolts & washers. Secure cable plate to transfer case with two 8-mm bolts & washers. All bolts should be tightened to the specified torque.

Tightening torque:

16 N·m (1.6 kg-m, 12 ft-lb)

11) Adjustment of cable

- (1) Connect transfer shifter lever to transfer shifter shaft. Align the hole in transfer shifter lever with that in shifter shaft and drive spring pin into the holes.
 (2) Connect a hose to pipe on the outside of actuator and apply vacuum pressure until cable is shortened as much as possible.

Use a vacuum pump or intake manifold to create vacuum.

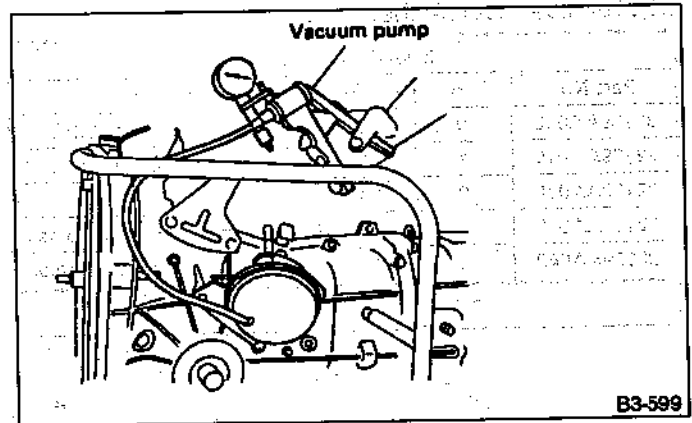


Fig. 66

- (3) While applying vacuum pressure, turn turnbuckle in the direction that shortens cable until it no longer turns. Then, back off turnbuckle 180° and tighten two lock nuts to the specified torque.

Tightening torque:

5 N·m (0.5 kg-m, 3.6 ft-lb)

- (4) Operate actuator to ensure that shifting from front-wheel drive to 4-wheel drive is smooth.

- 12) Install transfer cover with gasket and tighten bolts.

Tightening torque:

15 — 18 N·m (1.5 — 1.8 kg-m, 11 — 13 ft-lb)

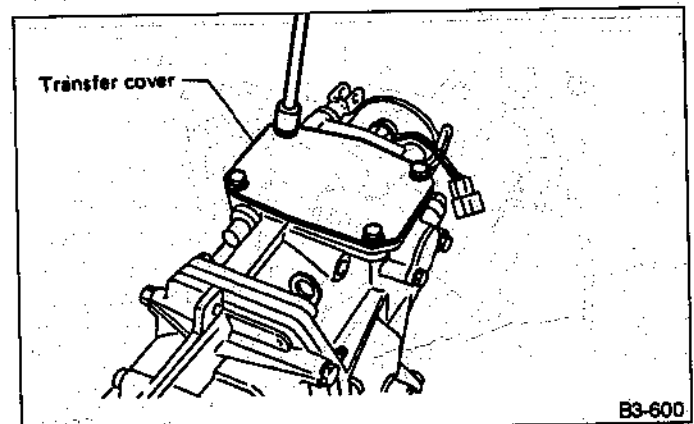


Fig. 67

- 13) Connect transmission cord connectors.

4. Rear Case (FWD)

A: DISASSEMBLY

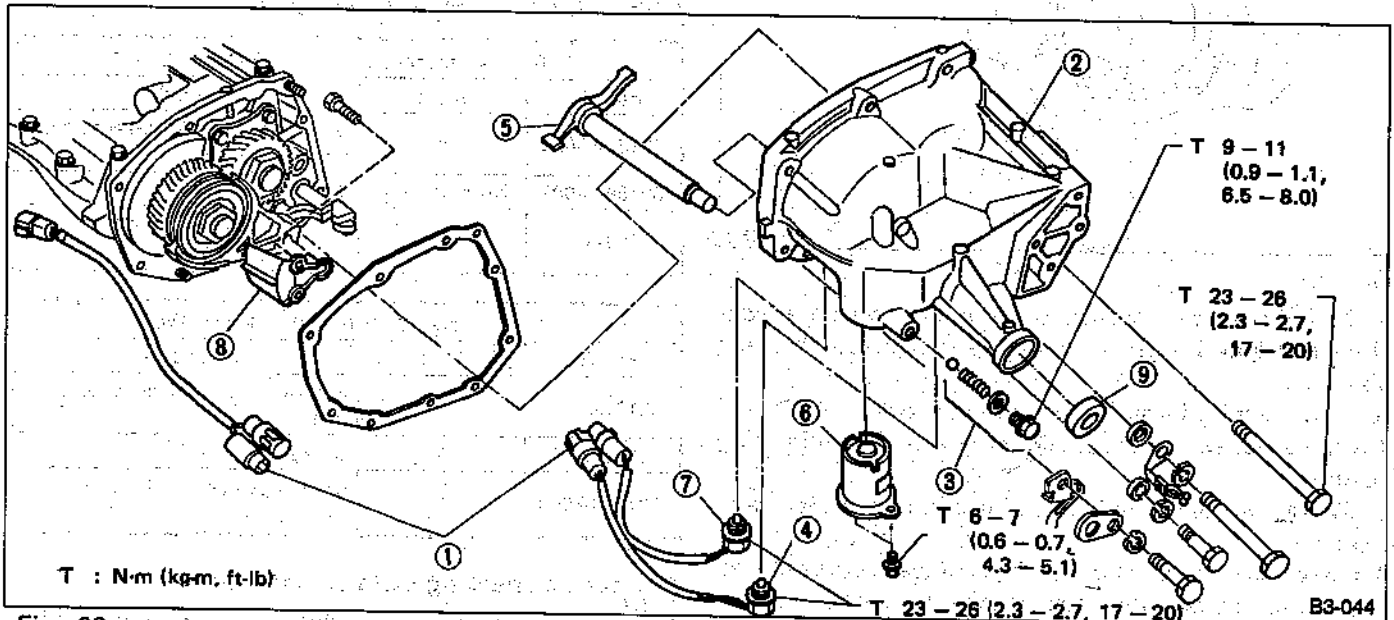


Fig. 68

- 1) Disconnect each connector of transmission cord.
- 2) Remove rear case.
- 3) Remove plug, spring and reverse check ball.
- 4) Remove neutral switch.
- 5) Pull out shifter arm and selector arm.
- 6) Remove reverse checking sleeve.

Procedure for disassembly is as follows:

- Reverse check sleeve ASSY uses an O-ring which should not be scratched.
- Be careful not to break adjustment shim placed between reverse check sleeve ASSY and case.

- (2) Remove reverse checking plate.
- (3) Remove reverse checking spring with cam.
- (4) Remove reverse return spring.
- (5) Remove reverse accent shaft.
- (6) Remove O-ring.
- 7) Remove back-up light switch.
- 8) Remove oil guide.
- 9) Removal of oil seal.
Do not reuse oil seal.

B: ASSEMBLY

Assembly of rear case is in the reverse order of disassembly. Observe the following.

- 1) Assembly of reverse checking sleeve.
 - (1) Install reverse accent shaft, checking cam, return spring and checking spring onto reverse checking sleeve.

Be sure the bent section of reverse checking spring is positioned in the groove in checking cam.

 - (2) Hook the bent section of reverse checking spring over reverse check plate.
 - (3) Rotate cam so that the protrusion of reverse checking cam is at the opening in plate.
 - (4) With cam held in that position, install plate onto reverse checking sleeve and hold with snap ring (Inner-28).
 - (5) Position O-ring (35.4 x 1.5) in groove in sleeve.

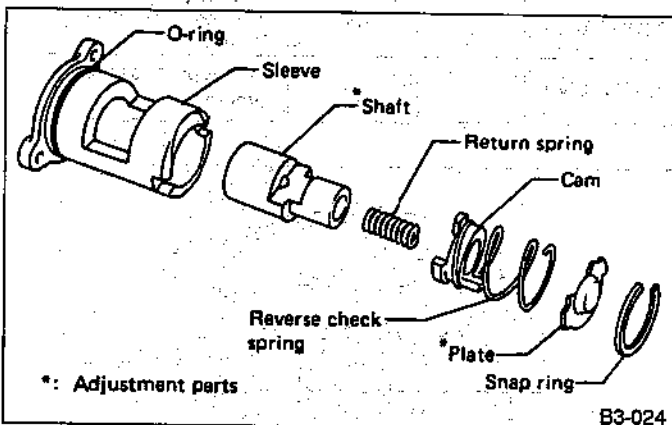


Fig. 69

- (1) Using a standard screwdriver, remove snap ring (inner 28).

Replace snap ring a new one if deformed or weakened.

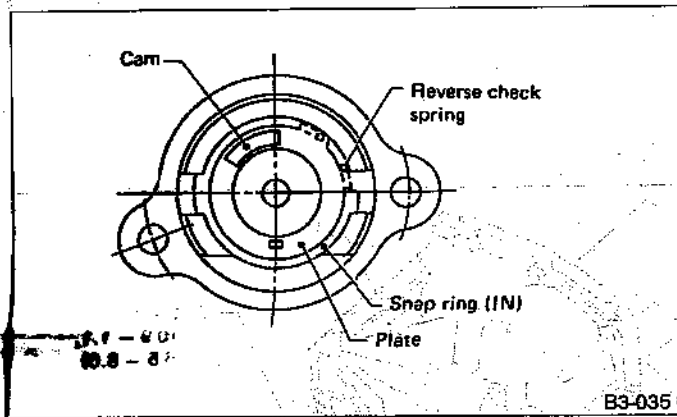


Fig. 70

- a. Make sure the cutout section of reverse accent shaft is aligned with the opening in reverse checking sleeve.
- b. Spin cam by hand for smooth rotation. If it does not return properly, replace reverse checking spring.
- c. Move cam and shaft all the way toward plate and release. If cam does not return properly, replace reverse checking spring; if shaft does not, check for scratches on the inner surface of sleeve. If sleeve is in good order, replace spring.
- d. Select a suitable reverse accent shaft and reverse check plate by referring to "Neutral Position Adjustment."

2) Installation of shifter arm and selector arm.
Install shifter arm into the partition from the front while inserting selector arm into the opening in reverse checking sleeve. Pass shaft through hole in selector arm until its end comes out of the rear of transfer case. Apply a coat of gear oil to shifter arm CP. Also make sure oil seal is positioned properly.

3) Adjustment of neutral position.
After assembling and installing rear case, adjust neutral position.

- (1) Shift gear into 3rd gear position.
- (2) Shifter arm turns lightly toward the 1st/2nd gear side but heavily toward the reverse gear side because of the function of the return spring; until arm contacts the stopper.
- (3) Make adjustment so that the heavy stroke (reverse side) is a little more than the light stroke (1st/2nd side).
- (4) To adjust, remove bolts holding reverse check sleeve ASSY to the case, move sleeve ASSY outward, and place adjustment shim (0 to 1 ea.) between sleeve ASSY and case to adjust the clearance.

Be careful not to break O-ring when placing shim(s).

Adjustment shim	
Part No.	Thickness mm (in)
32190AA000	0.15 (0.0059)
32190AA010	0.30 (0.0118)

- When shim is removed, the neutral position will move closer to reverse; when shim is added, the neutral position will move closer to 1st gear.
- If shims alone cannot adjust the clearance, replace reverse accent shaft and re-adjust.

Reverse accent shaft (2000*2200cc FWD)		
Part No.	Mark	Remarks
32188AA020	A	Neutral position is closer to 1st gear.
32188AA002	No mark or B	Standard
32188AA030	C	Neutral position is closer to reverse gear.

Reverse accent shaft (1600*1800cc FWD)		
Part No.	Mark	Remarks
32188AA040	1	Neutral position is closer to 1st gear.
32188AA011	2	Standard
32188AA050	3	Neutral position is closer to reverse gear.

4) Reverse checking plate adjustment.
After assembling and installing rear case, adjust reverse checking plate.

Shift shifter arm CP to "5th" and then to reverse to see if reverse checking mechanism operates properly. Also check to see if arm returns to Neutral when released from the reverse position. If arm does not return properly, replace reverse checking plate.

Reverse checking plate			
Part No.	No.	Angle θ	Remarks
32189AA000	0	28°	Arm stops closer to "5th".
32189AA010	1	31°	Arm stops closer to "5th".
32189AA020	2	34°	Standard
32189AA030	3	37°	Arm stops closer to reverse.
32189AA040	4	40°	Arm stops closer to reverse.

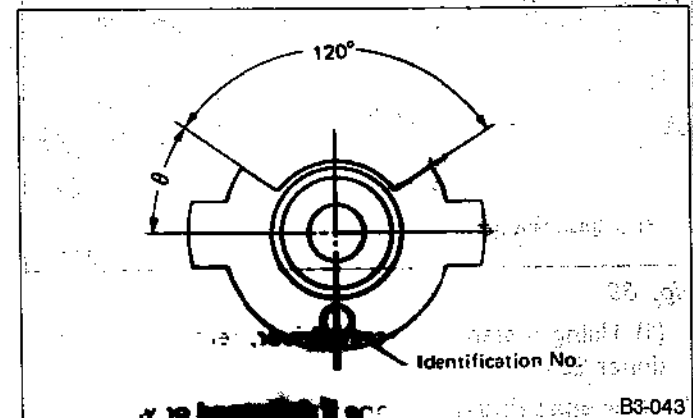
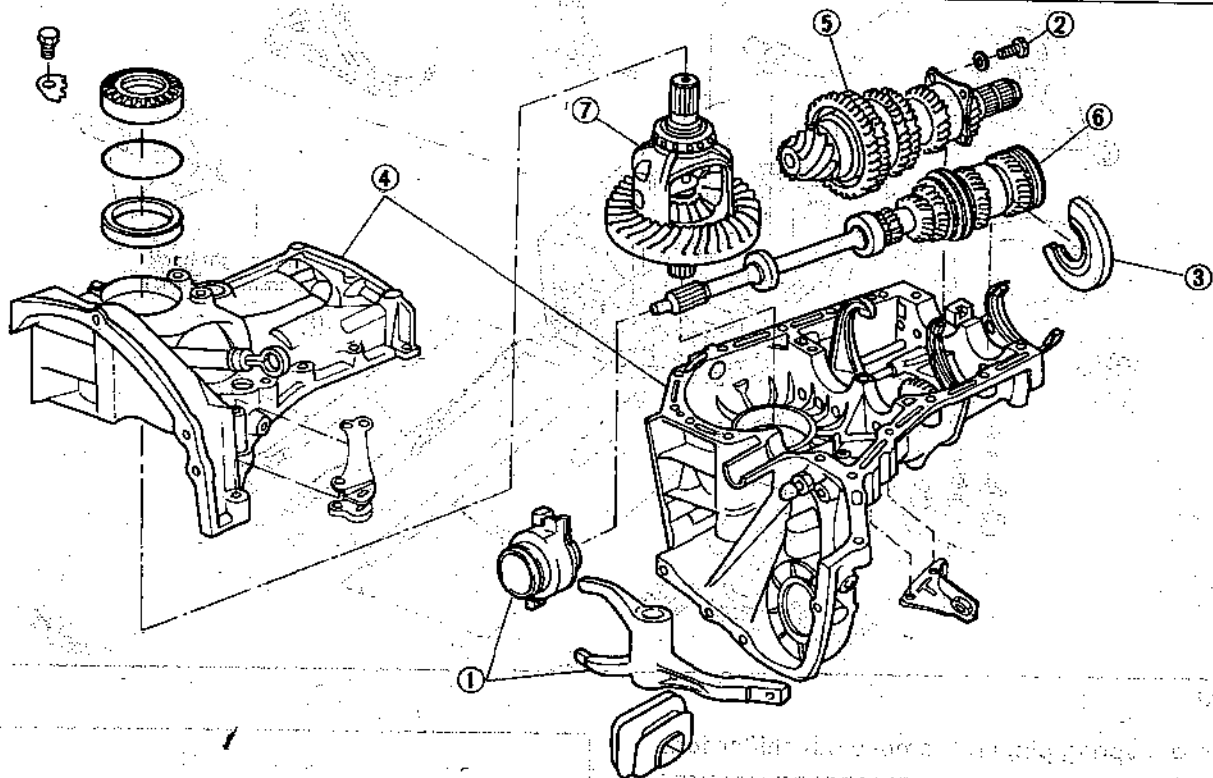


Fig. 71

Transmission Case (4WD Single-range and 2000-2200cc FWD) RT

A: DISASSEMBLY

2. SEPARATION OF TRANSMISSION

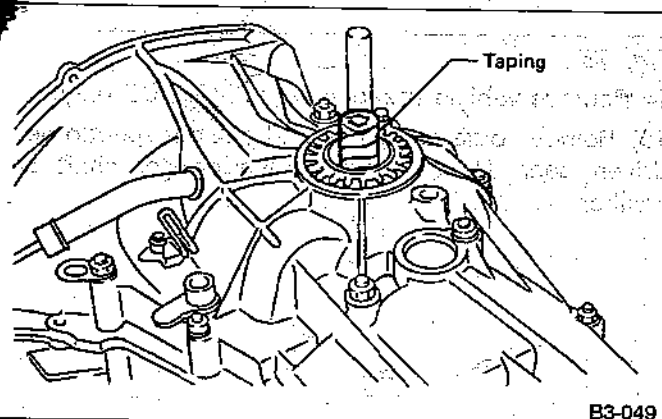


B3-861

Fig. 72

- 1) Remove clutch release lever and bearing. (Refer to 10 clutch.)
- 2) Remove bearing mounting bolts.
- 3) Remove main shaft rear plate.
- 4) Separating transmission case.
- (1) Put vinyl tape around splines of right and left axle drive shafts to prevent damage to oil seals.

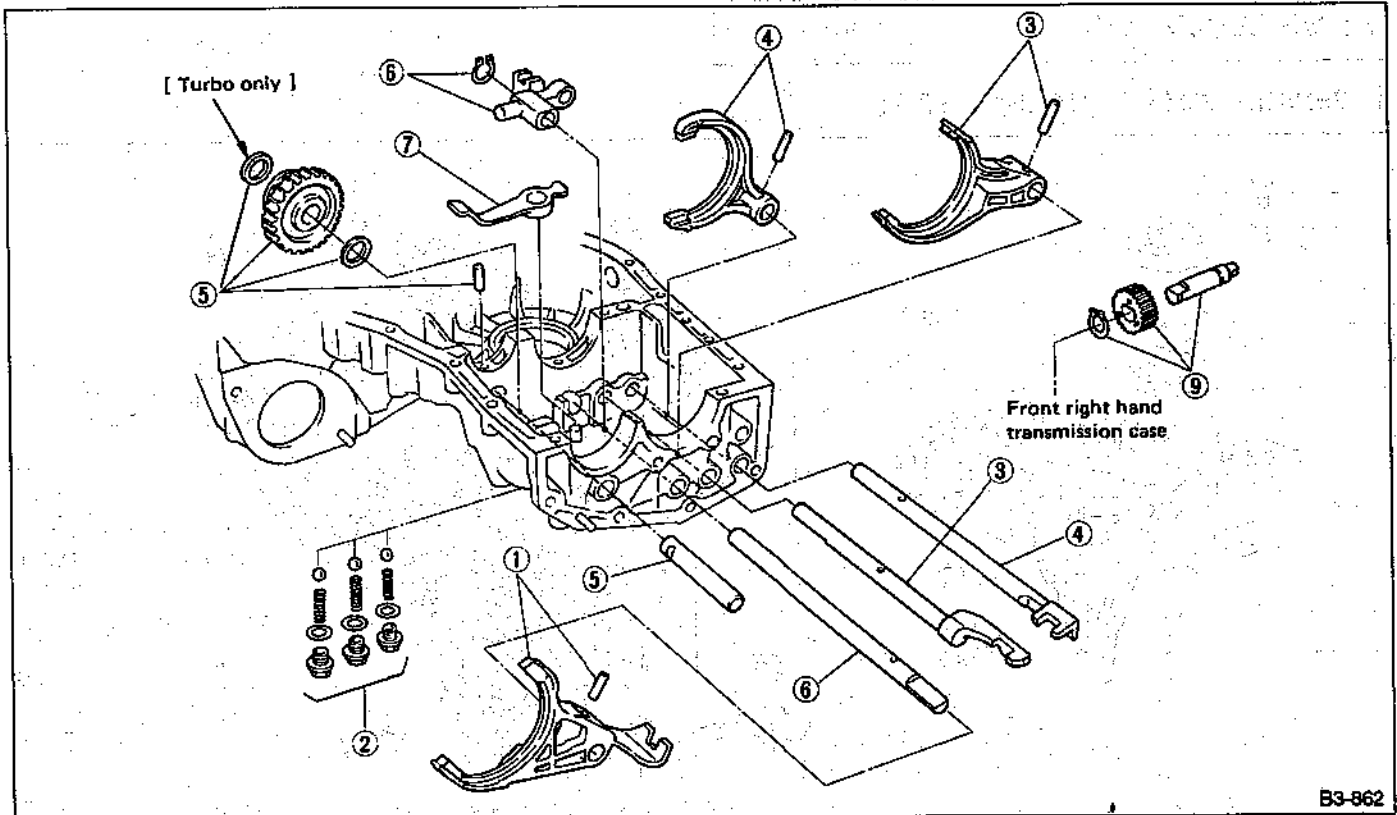
- (2) Separate transmission case into right and left cases by loosening seventeen coupling bolts and nuts.
- 5) Remove drive pinion shaft ASSY from LH transmission case.
Use a hammer handle, etc. to remove if too tight.
- 6) Remove main shaft ASSY.
- 7) Remove differential ASSY.
 - a. Be careful not to confuse right and left roller bearing outer races.
 - b. Be careful not to damage retainer oil seal.



B3-049

Fig. 73

2. TRANSMISSION CASE



B3-862

Fig. 74

1) Drive out spring pin, and remove 5th shifter fork.

Special tool:

STRAIGHT PIN REMOVER 2: 398791700

- 2) Remove plugs, springs and checking balls.
- 3) Drive out spring pin, and pull out 3-4 fork rod and shifter fork.

When removing rod, keep other rods in neutral. Also, when pulling out spring pin, remove it toward inside of case so that it may not hit against case.

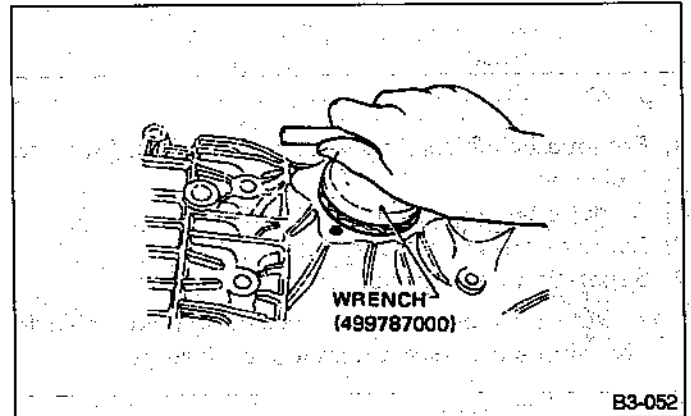
4) Drive out spring pin, and pull out 1-2 fork rod and shifter fork.

5) Pull out straight pin, and remove idler gear shaft, reverse idler gear and washer.

6) Remove outer snap ring, and pull out reverse shifter rod arm from reverse fork rod. Then take out ball, spring and interlock plunger from rod. And then remove rod.

When pulling out reverse shifter rod arm, be careful not to let ball pop out of arm.

- 7) Remove reverse shifter lever.
- 8) Remove differential side retainers.



B3-052

Fig. 75

- 9) Remove vehicle speed sensor 2. (TURBO only)
- 10) Remove outer snap ring and pull out speedometer driven gear. Next, remove speedometer shaft and washer.

B: ASSEMBLY

1. TRANSMISSION CASE

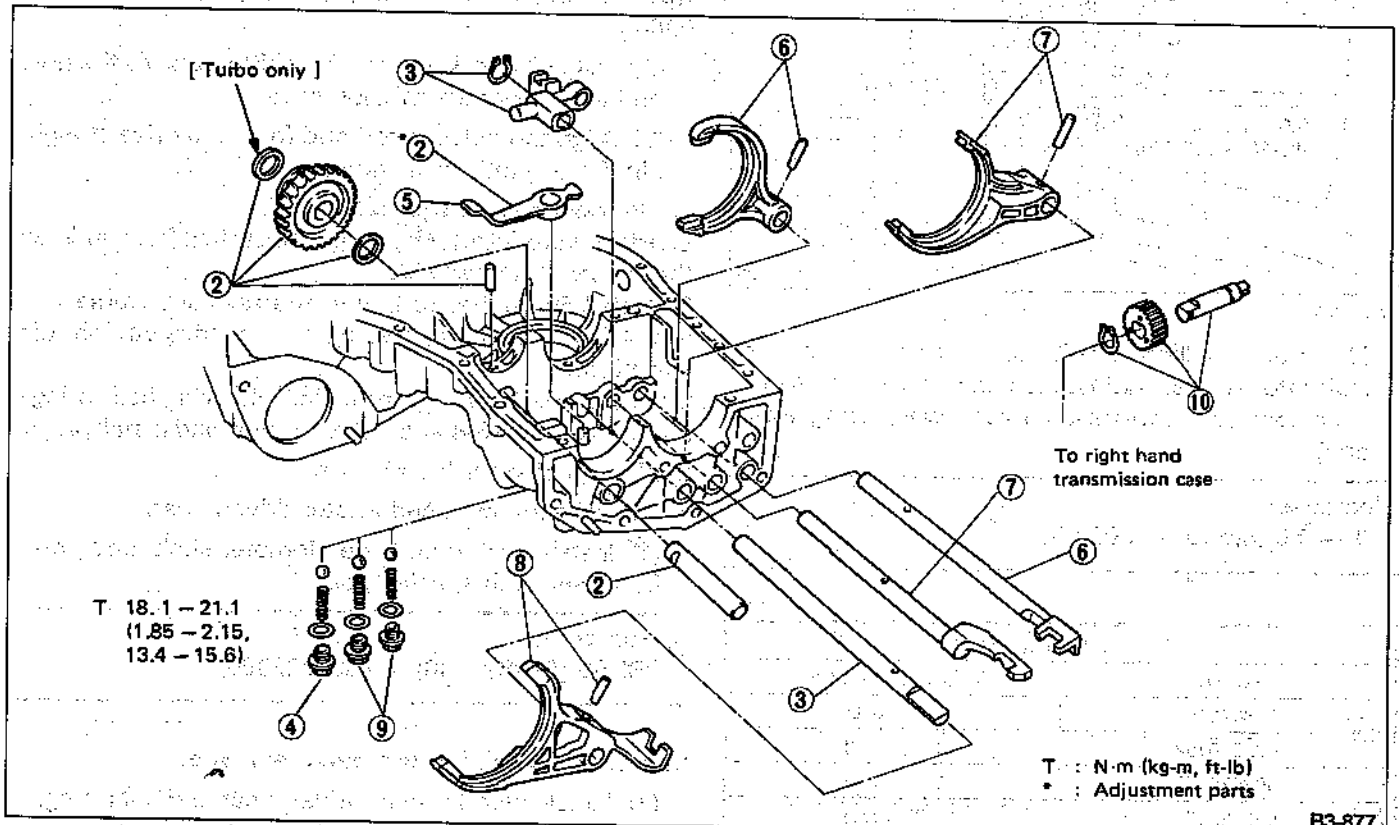


Fig. 76

- 1) Position interlock plungers (5.56 x 19.6), one plunger in hole between 1-2 and 3-4 fork rod holes, and one plunger in hole between 3-4 and reverse fork rod holes.
- 2) Install reverse shifter lever, reverse idler gear and reverse idler gear shaft, and secure with straight pin.

a. Be sure to install reverse idler shaft from the rear side.

b. On turbo model, there is a washer on the front side of reverse idler gear, too.

- 3) Install reverse arm fork spring, ball and interlock plunger (5.56 x 19.6) to reverse fork rod arm. Insert reverse fork rod into hole in reverse fork rod arm, and hold it with outer snap ring using special tool.

Apply grease to plunger to prevent it from falling.

Special tool:

ACCENT BALL INSTALLER (399411700)

- (1) Move reverse shifter rod toward REV side. Adjust clearance between reverse idler gear and transmission case wall, using reverse shifter lever.

Clearance:

6.0 — 7.5 mm (0.236 — 0.295 in)

Reverse shifter lever		
Part No.	No.	Remarks
32820AA000	0	Further from case wall.
32820AA010	—	Standard
32820AA020	2	Closer to case wall.

- 4) Position ball (7.1438), spring and gasket in reverse shifter rod hole, on L.H. transmission case, and tighten checking ball plug.

Replace gasket with a new one.

- 5) Adjustment of reverse idler gear position.

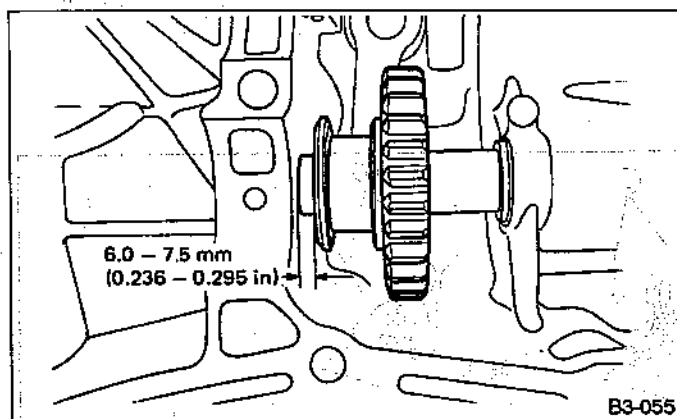


Fig. 77

(2) After installing a suitable reverse shifter lever, shift into Neutral. Adjust clearance between reverse idler gear and transmission case wall, using washer(s).

Clearance:

0 - 0.5 mm (0 - 0.020 in)

Washer (20.5 x 26 x t)	
Part No.	Thickness mm (in)
803020151	0.4 (0.016)
803020152	1.1 (0.043)
803020153	1.5 (0.059)
803020154	1.9 (0.075)
803020155	2.3 (0.091)

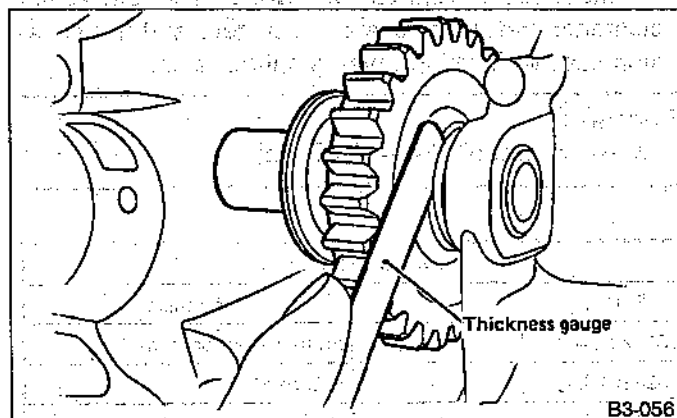


Fig. 78

6) Installation of 1-2 shifter fork and rod.

(1) Install 1-2 fork rod into 1-2 shifter fork via the hole on the rear of transmission case.

(2) Align the holes in rod and fork, and drive straight pin (6 x 22) into these holes using STRAIGHT PIN REMOVER (398791600).

a. Set other rods to Neutral.

b. Make sure interlock plunger (5.56 x 19.6) is on the 3-4 fork rod side.

7) Installation of 3-4 shifter fork and rod.

(1) Install interlock plunger (3 x 11.9) onto 3-4 fork rod.

Apply a coat of grease to plunger to prevent it from falling.

(2) Install 3-4 fork rod into 3-4 shifter fork via the hole on the rear of transmission case.

(3) Align the holes in rod and fork, and drive straight pin (6 x 22) into these holes.

a. Set reverse fork rod to Neutral.

b. Make sure interlock plunger (installed before) is on the reverse fork rod side.

8) Install 5th shifter fork onto the rear of reverse fork rod. Align holes in the two parts and drive straight pin into place.

9) Position balls (7.1438 mm dia.), checking ball springs and gaskets into 3-4 and 1-2 rod holes, and install plugs.

Replace gasket with a new one.

10) Installation of speedometer driven gear.

(1) Install washer and speedometer shaft, and press fit oil seal with special tool.

Special tool:

PRESS (899824100) or (499827000)

Use new oil seal, if it has been removed.

(2) Install speedometer driven gear and snap ring.

(3) Install vehicle speed sensor 2. (TURBO only)

Use new vehicle speed sensor 2, if it has been removed. (TURBO only)

2. COMBINATION OF TRANSMISSION CASE

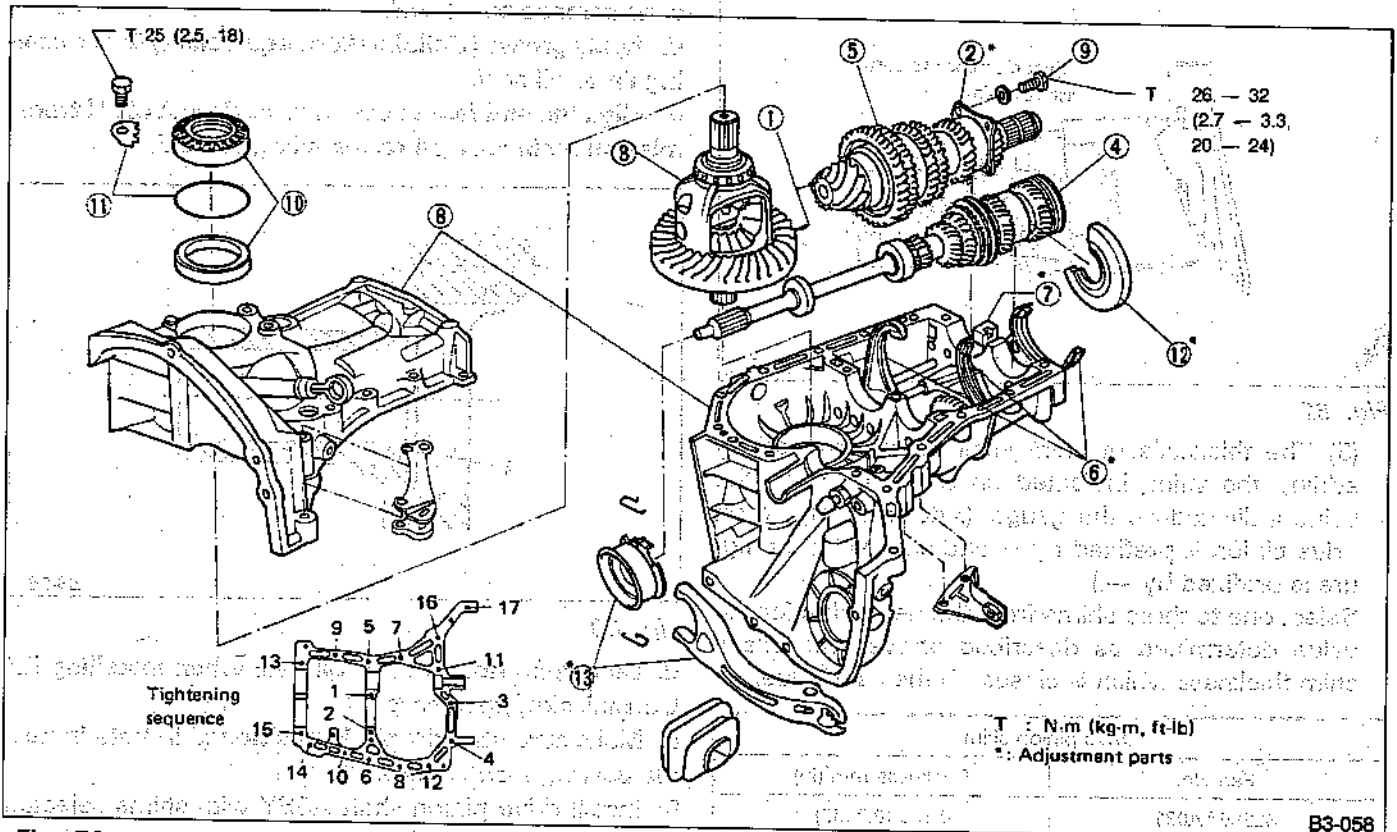


Fig. 79

1) Alignment marks/figures on hypoid gear set
The upper figure on driven pinion is the match number for combining it with crown gear. The lower figure is for shim adjustment. If no lower figure is shown, the value is zero. The figure on crown gear indicates a number for combination with drive pinion.

(2) Inspection and adjustment of GAUGE ASSY (499917500).
a. Loosen the two bolts and adjust so that the scale indicates 0.5 correctly when the plate end and the scale end are on the same level.
b. Tighten two bolts.

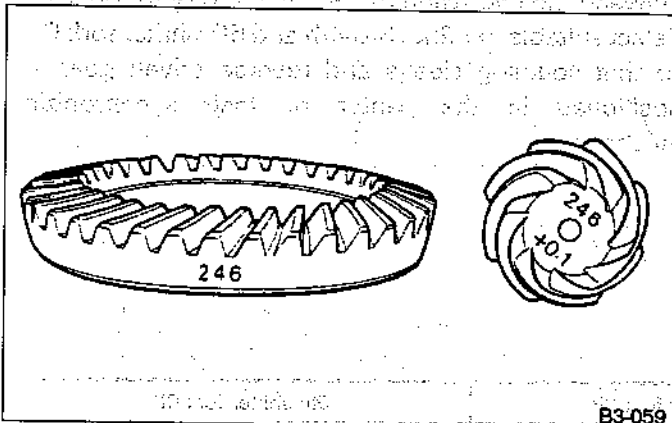


Fig. 80

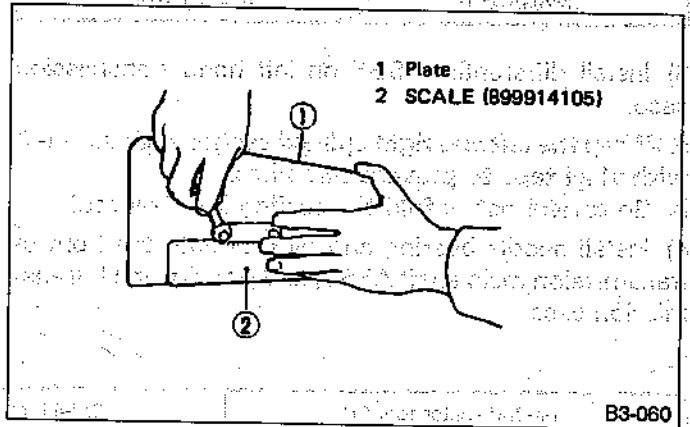


Fig. 81

2) Adjustment of drive pinion shim
(1) Place drive pinion shaft ASSY on right hand transmission main case without shim and tighten bearing mounting bolts.

(3) Position the gauge by inserting the knock pin of gauge into the knock hole in the transmission case.
(4) Slide the drive pinion gauge scale with finger tip and read the value at the point where it matches with the end face of drive pinion.

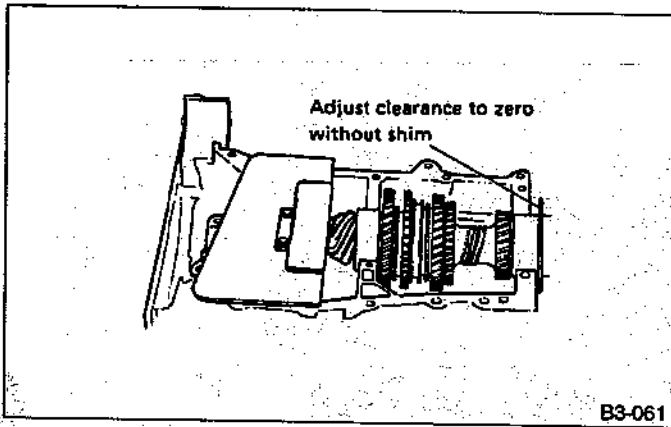


Fig. 82

(5) The thickness of shim shall be determined by adding the value indicated on drive pinion to the value indicated on the gauge. (Add if the figure on drive pinion is prefixed by + and subtract if the figure is prefixed by —.)

Select one to three shims from the next table for the value determined as described above and take a shim thickness which is closest to the said value.

Drive pinion shim	
Part No.	Thickness mm (in)
32295AA031	0.150 (0.0059)
32295AA041	0.175 (0.0069)
32295AA051	0.200 (0.0079)
32295AA061	0.225 (0.0089)
32295AA071	0.250 (0.0099)
32295AA081	0.275 (0.0108)
32295AA091	0.300 (0.0118)
32295AA101	0.500 (0.0197)

3) Install differential ASSY on left hand transmission case.

a. Wrap the left and right splined sections of axle shaft with vinyl tape to prevent scratches.

b. Be careful not to fold the sealing lip of oil seal.

4) Install needle bearing and oil seal onto the front of transmission main shaft ASSY, and position in LH transmission case.

- a. Wrap clutch splined section with vinyl tape to prevent damage to oil seal.
- b. Apply grease (Unilube #2 or equivalent) to the sealing lip of oil seal.
- c. Align the end face of seal with surface A of LH transmission main case when installing oil seal.

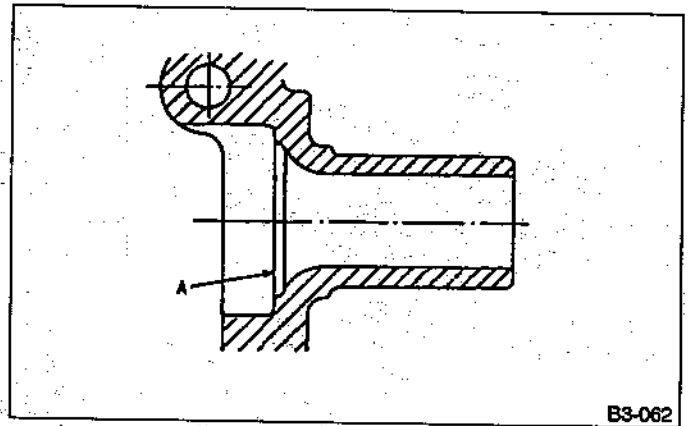


Fig. 83

d. Be careful not to drop oil seal when installing RH transmission main case.

e. Make sure straight pin is positioned in hole in needle bearing's outer race.

5) Install drive pinion shaft ASSY with shims selected before into transmission case.

Ensure that the knock pin of the case is fitted into the hole in the bearing outer race.

6) Selection of suitable 1st-2nd, 3rd-4th and 5th shifter fork CP's.

Set transmission main shaft ASSY and drive pinion shaft ASSY in position (so there is no clearance between the two when moved all the way to the front). Select suitable 1st-2nd, 3rd-4th and 5th shifter fork CP's so that coupling sleeve and reverse driven gear are positioned in the center of their synchronizing mechanisms.

1st-2nd shifter fork CP			3rd-4th shifter fork CP			5th shifter fork CP		
Part No.	No.	Remarks	Part No.	No.	Remarks	Part No.	No.	Remarks
32804AA060	1	Moves 0.2 mm (0.008 in) closer to 1st gear	32810AA060	1	Moves 0.2 mm (0.008 in) closer to 4th gear	32812AA060	1	Moves 0.2 mm (0.008 in) closer to 5th gear
32804AA070	—	Positions in the center	32810AA070	—	Positions in the center	32812AA070	—	Positions in the center
32804AA080	3	Moves 0.2 mm (0.008 in) closer to 2nd gear	32810AA100	3	Moves 0.2 mm (0.008 in) closer to 3rd gear	32812AA100	3	Moves 0.2 mm (0.008 in) further from 5th gear

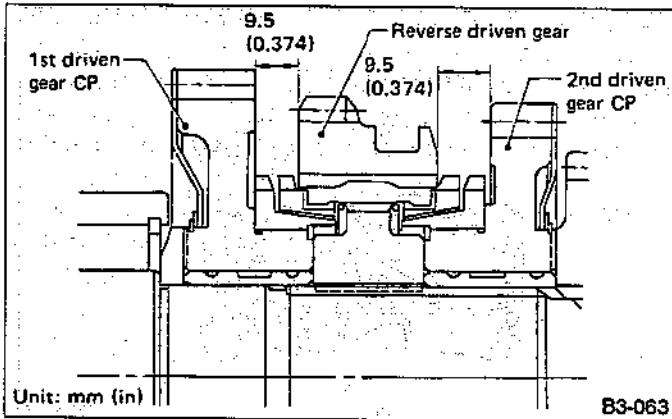


Fig. 84

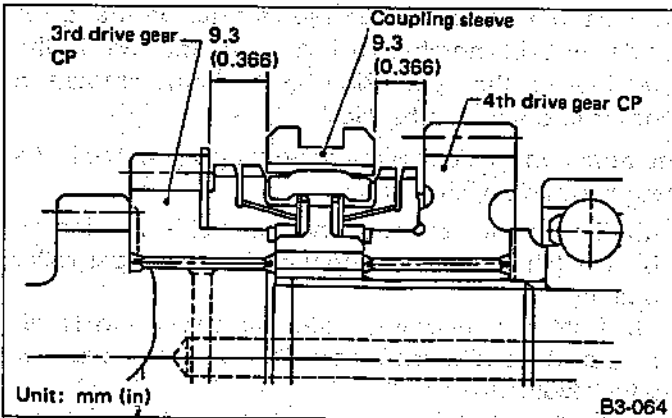


Fig. 85

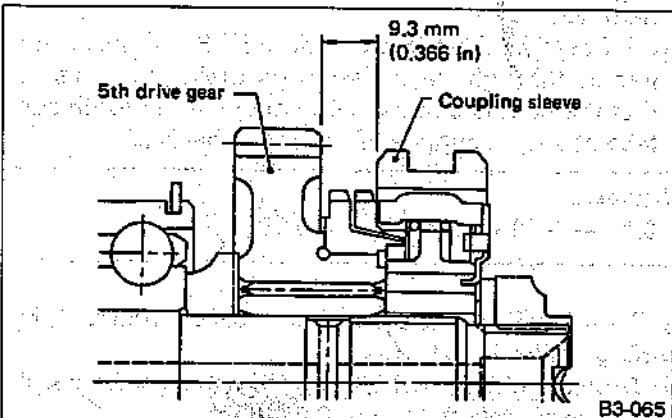


Fig. 86

7) Inspection of rod end clearance.
Measure rod end clearances A and B. If any clearance is not within specifications, replace rod or fork as required.

A: 1st-2nd to 3rd-4th	0.5 — 1.5 mm (0.020 — 0.059 in)
B: 3rd-4th to 5th	0.6 — 1.4 mm (0.024 — 0.055 in)

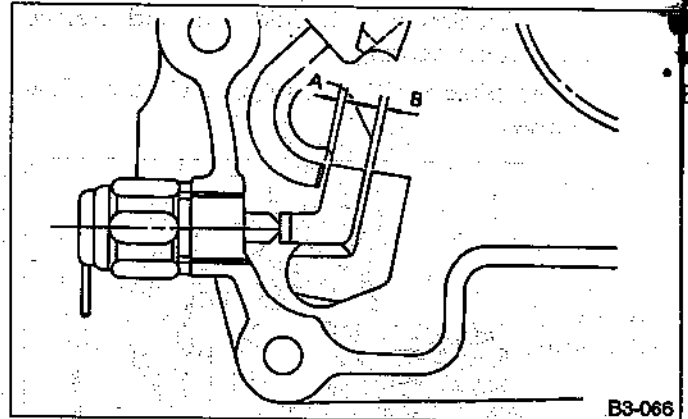


Fig. 87

8) Combination of transmission case.

(1) Wipe off grease, oil and dust on the mating surfaces of transmission cases with white gasoline, and apply liquid gasket, and then put case right hand and left hand together.

Liquid gasket:

Three-bond 1215 or equivalent

(2) Tighten 17 bolts with bracket, clip, etc. in the following sequence.

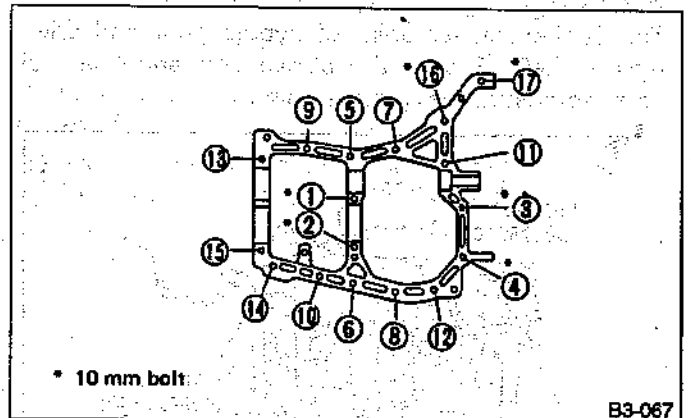


Fig. 88

Tightening torque:

8 mm bolt

23 — 26 N·m (2.3 — 2.7 kg-m, 17 — 20 ft-lb)

10 mm bolt

36 — 42 N·m (3.7 — 4.3 kg-m, 27 — 31 ft-lb)

a. Insert bolts from the bottom and tighten nuts at the top.

b. Put cases together so that drive pinion shim, input shaft holder shim are not caught up in between.

c. Confirm that counter gear and speedometer gear are meshed, and high-low shifter shaft is inserted correctly.

9) Tighten ball bearing attachment bolts.

10) Backlash adjustment of hypoid gear and preload adjustment of roller bearing.

Support drive pinion ASSY with special tool. [Full-time 4WD only]

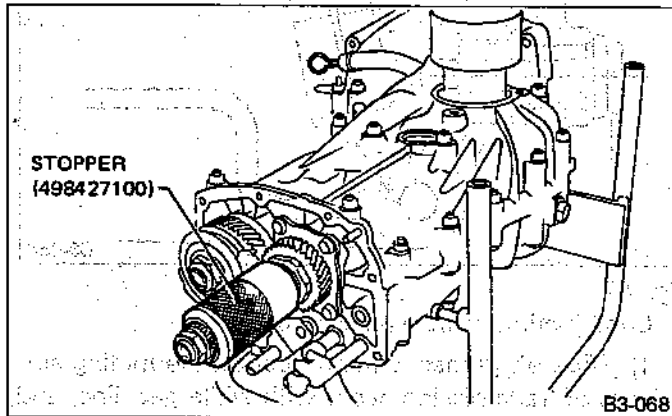


Fig. 89

(1) Place the transmission with case left hand facing downward and put WEIGHT on bearing cup.

(2) Screw retainer ASSY into case left hand from the bottom with WRENCH. Fit HANDLE on the transmission main shaft. Shift gear into 4th or 5th and turn the shaft several times. Screw in the retainer while turning HANDLE until a slight resistance is felt on WRENCH.

This is the contact point of hypoid gear and drive pinion shaft. Repeat the above sequence several times to ensure the contact point.

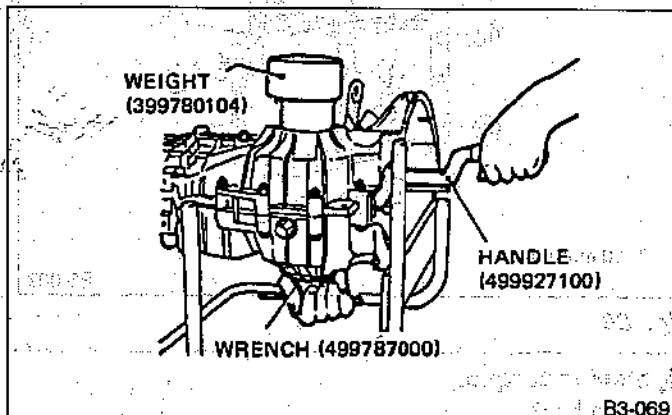


Fig. 90

(3) Remove weight and screw in retainer without O-ring on the upper side and stop at the point where slight resistance is felt.

At this point, the backlash between the hypoid gear and drive pinion shaft is zero.

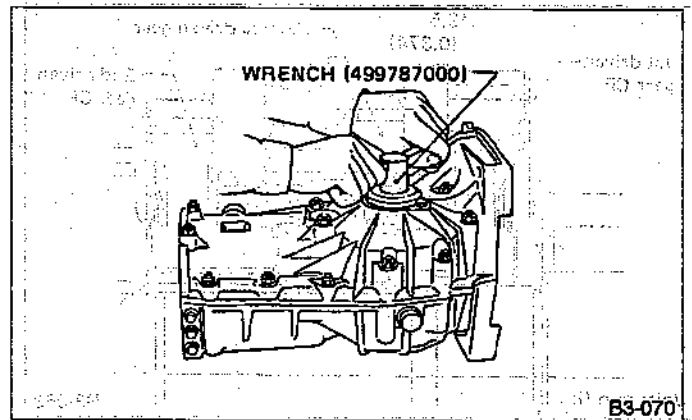


Fig. 91

(4) Fit lock plate. Loosen the retainer on the lower side by 1-1/2 notches of lock plate and turn in the retainer on the upper side by the same amount in order to obtain the backlash.

The notch on the lock plate moves by 1/2 notch if the plate is turned upside down.

(5) Turn in the retainer on the upper side additionally by 1 notch in order to apply preload on taper roller bearing.

(6) Tighten temporarily both the upper and lower lock plates and mark both holder and lock plate for later readjustment.

(7) Turn transmission main shaft dozens of turns while tapping around retainer lightly with plastic hammer.

(8) Set DIAL GAUGE and MAGNET BASE. Insert the needle through transmission oil drain plug hole so that the needle comes in contact with the tooth surface at a right angle and check the backlash.

Backlash:

0.13 — 0.18 mm (0.0051 — 0.0071 in)

a) If backlash outside specified range, adjust it by turning holder in RH case.

b) Turning holder pawl 1/2 rotation changes backlash by approximately 0.04 mm (0.0016 in).

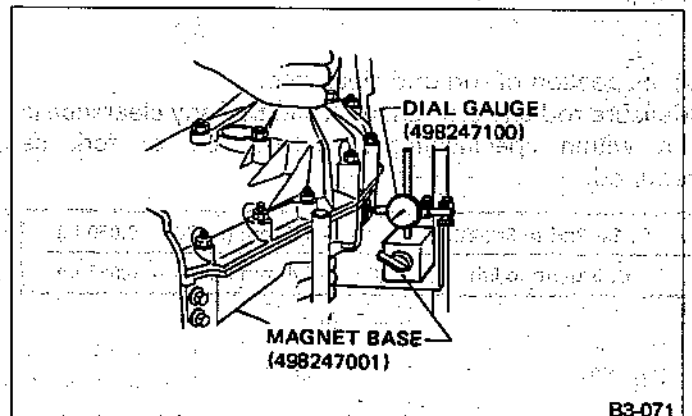


Fig. 92

(9) Check tooth contact of hypoid gear as follows: Apply a uniform thin coat of red lead on both tooth surfaces of 3 or 4 teeth of the hypoid gear. Move the hypoid gear back and forth by turning the transmission main shaft until a definite contact pattern is developed on hypoid gear, and judge whether face contact is correct. If it is incorrect, make the following correction.

- Tooth contact is correct.

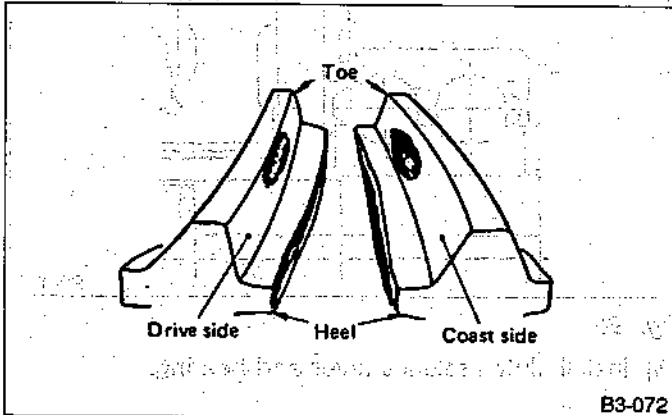


Fig. 93

- Backlash is excessive. To reduce backlash, loosen holder on the upper side (case R.H. side) and turn in the holder on the lower side (case L.H. side) by the same amount.

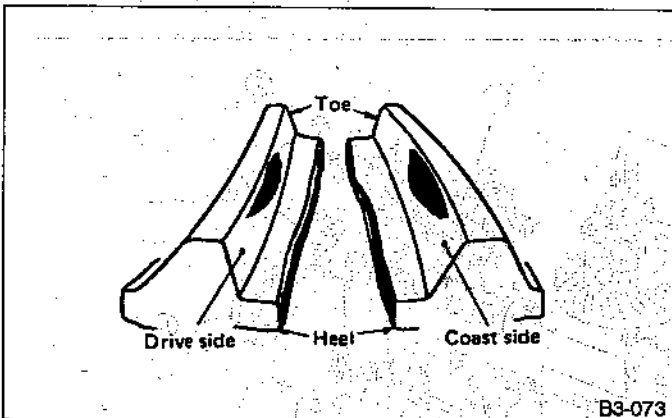


Fig. 94

- Backlash is insufficient. To increase backlash, loosen holder on the lower side (case L.H. side) and turn in the holder on the upper side (case R.H. side) by the same amount.

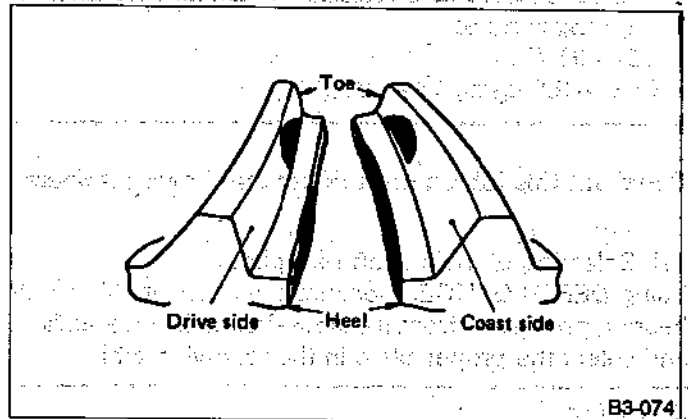


Fig. 95

- The drive pinion shim selected before is too thick. Reduce its thickness.

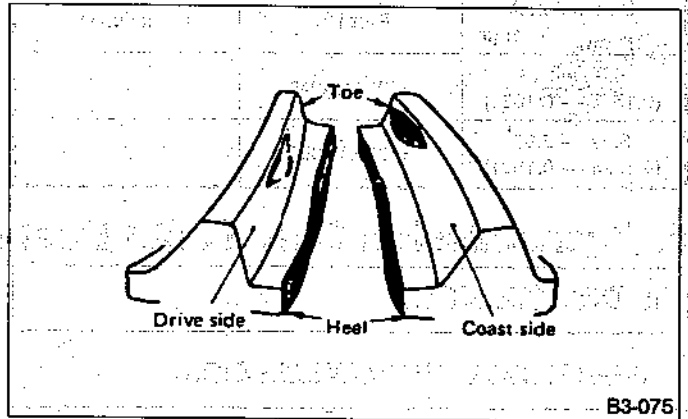


Fig. 96

- The drive pinion shim selected before is too thin. Increase its thickness.

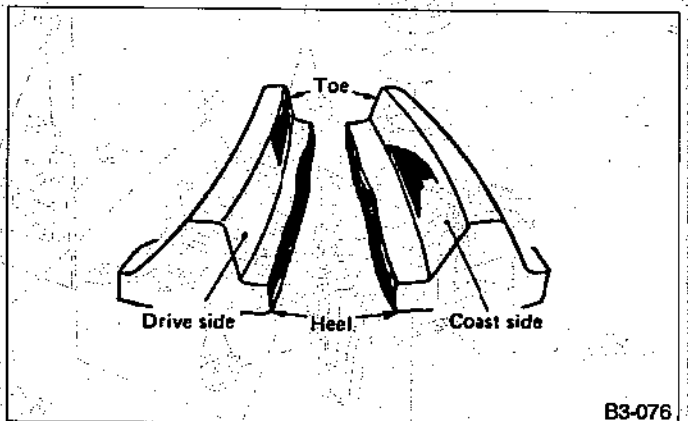


Fig. 97

11) After checking the tooth contact of hypoid gears, remove the lock plate. Then loosen retainer until the O-ring groove appears. Fit O-ring into the groove and tighten retainer into the position where retainer has been tightened in. Tighten lock plate.

Tightening torque:

22 — 27 N·m

(2.2 — 2.8 kg-m, 16 — 20 ft-lb)

Carry out this job on both upper and lower retainers.

12) Selecting of main shaft rear plate.

Using DEPTH GAUGE, measure the amount (A) of ball bearing protrusion from transmission main case surface and select the proper plate in the following table.

Special tool:**DEPTH GAUGE (498147000)**

Dimension A mm (in)	Part No.	Identification
4.0 — 4.13 (0.1575 — 0.1626)	32294AA040	1
3.87 — 3.99 (0.1524 — 0.1571)	32294AA050	2

Before measuring, tap the end of main shaft by the plastic hammer lightly in order to make the clearance zero between the main case surface and the moving flange of bearing.

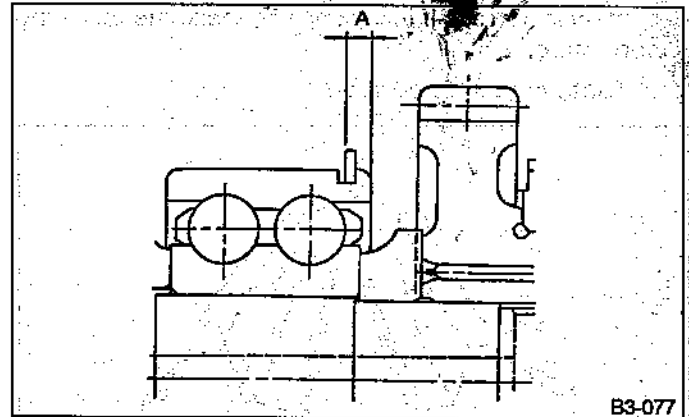


Fig. 98

13) Install clutch release lever and bearing.

6. Transmission Case (4WD Dual-range)

A: DISASSEMBLY

1. SEPARATION OF TRANSMISSION

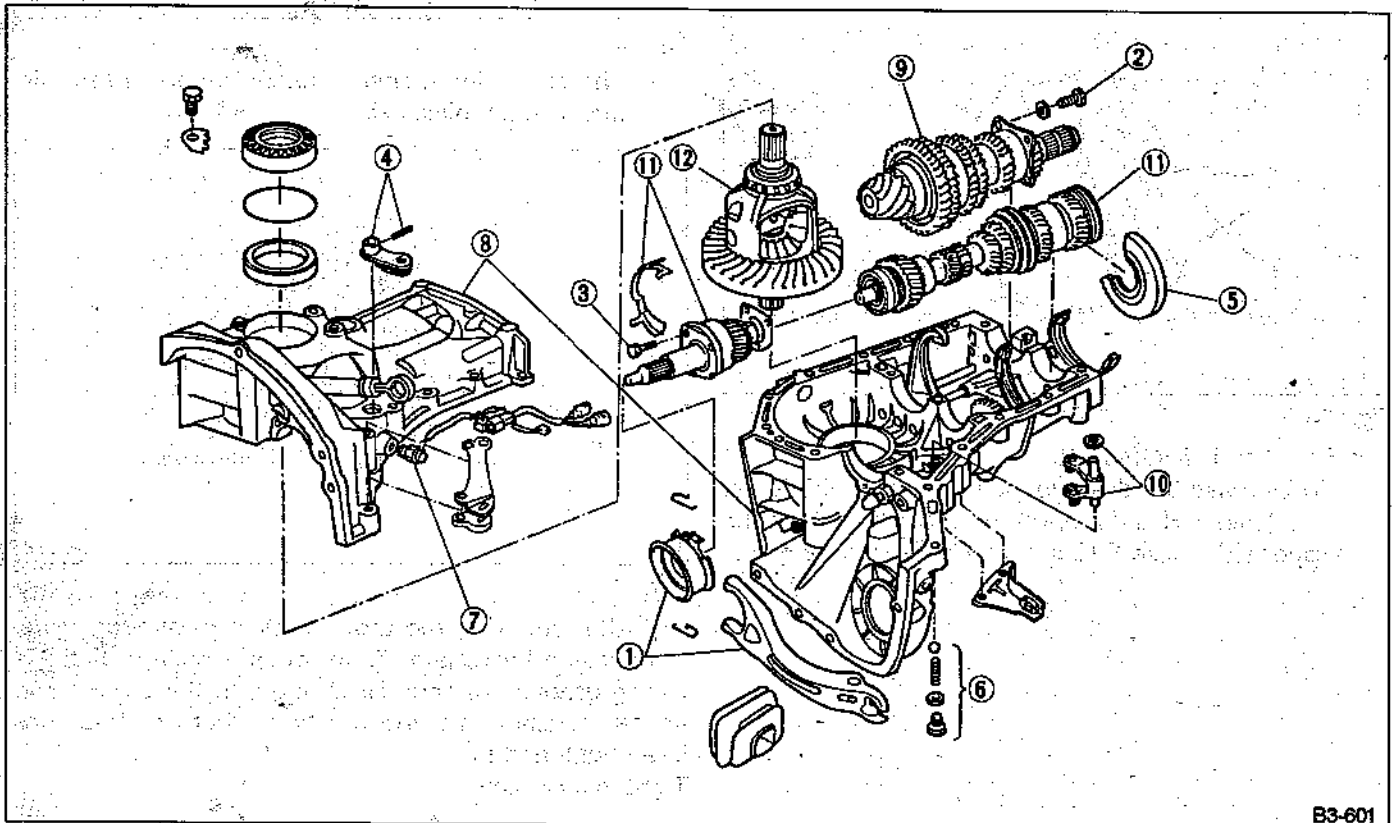


Fig. 99

- 1) Remove clutch release lever and bearing. (Refer to 2-11 clutch.)
- 2) Remove bearing mounting bolts.
- 3) Remove input shaft holder attaching bolts.
- 4) Using special tool, drive out straight pin, and remove high-low shifter lever.

Special tool:
STRAIGHT PIN REMOVER 2 (398791700)

When driving out straight pin (6 x 22), remove it in the direction that it does not butt against transmission case.

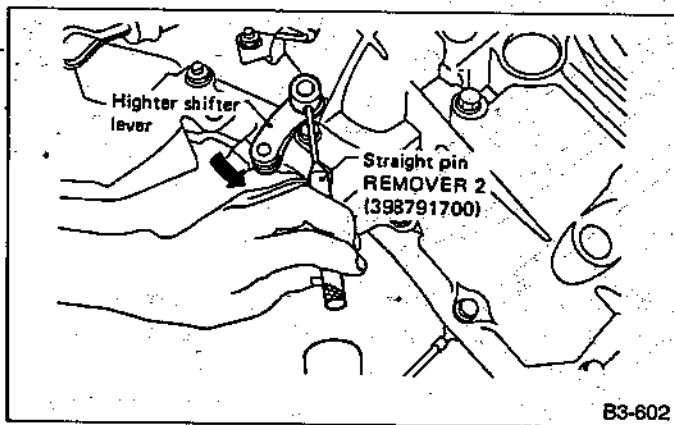


Fig. 100

- 5) Remove main shaft rear plate.
- 6) Remove plug, spring and ball.
- 7) Remove low switch.
- 8) Separating transmission case.

(1) Put vinyl tape around splines of right and left axle drive shafts to prevent damage to oil seals.

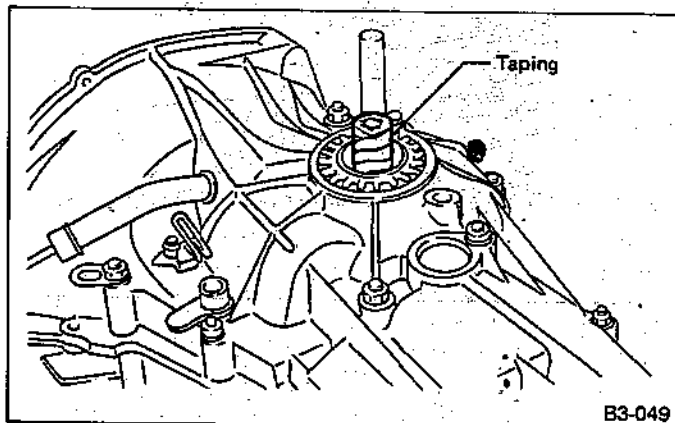


Fig. 101

(2) Separate transmission case into right and left cases by loosening seventeen coupling bolts and nuts.

Be careful of oil seal fitted in RH transmission case at point where shifter shaft projects.

- 9) Remove drive pinion shaft ASSY from LH transmission case.

Use a hammer handle, etc. to remove if too tight.

- 10) Removing high-low shifter fork.
 Raise main shaft ASSY slightly, and remove high-low shifter fork together with high-low shifter shaft and washer.

Be careful not to drop the two high-low shifter pieces.

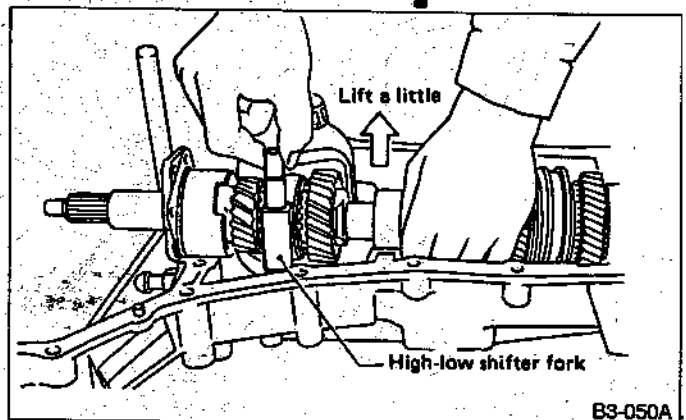


Fig. 102

- 11) Removing transmission main shaft ASSY and input shaft ASSY.

(1) Remove main shaft ASSY and input shaft ASSY. Be careful not to drop input shaft and main shaft as they are separable.

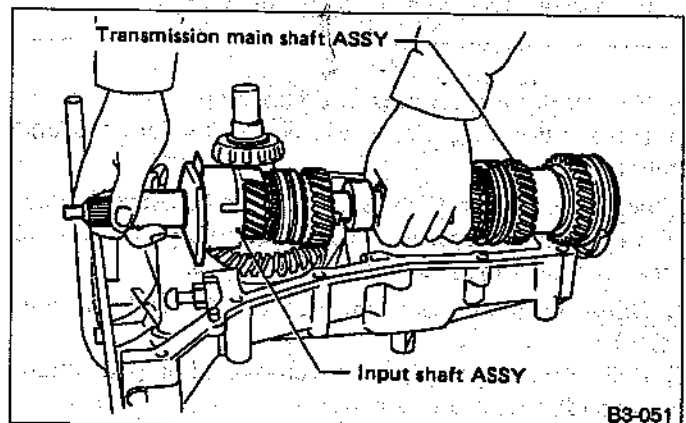
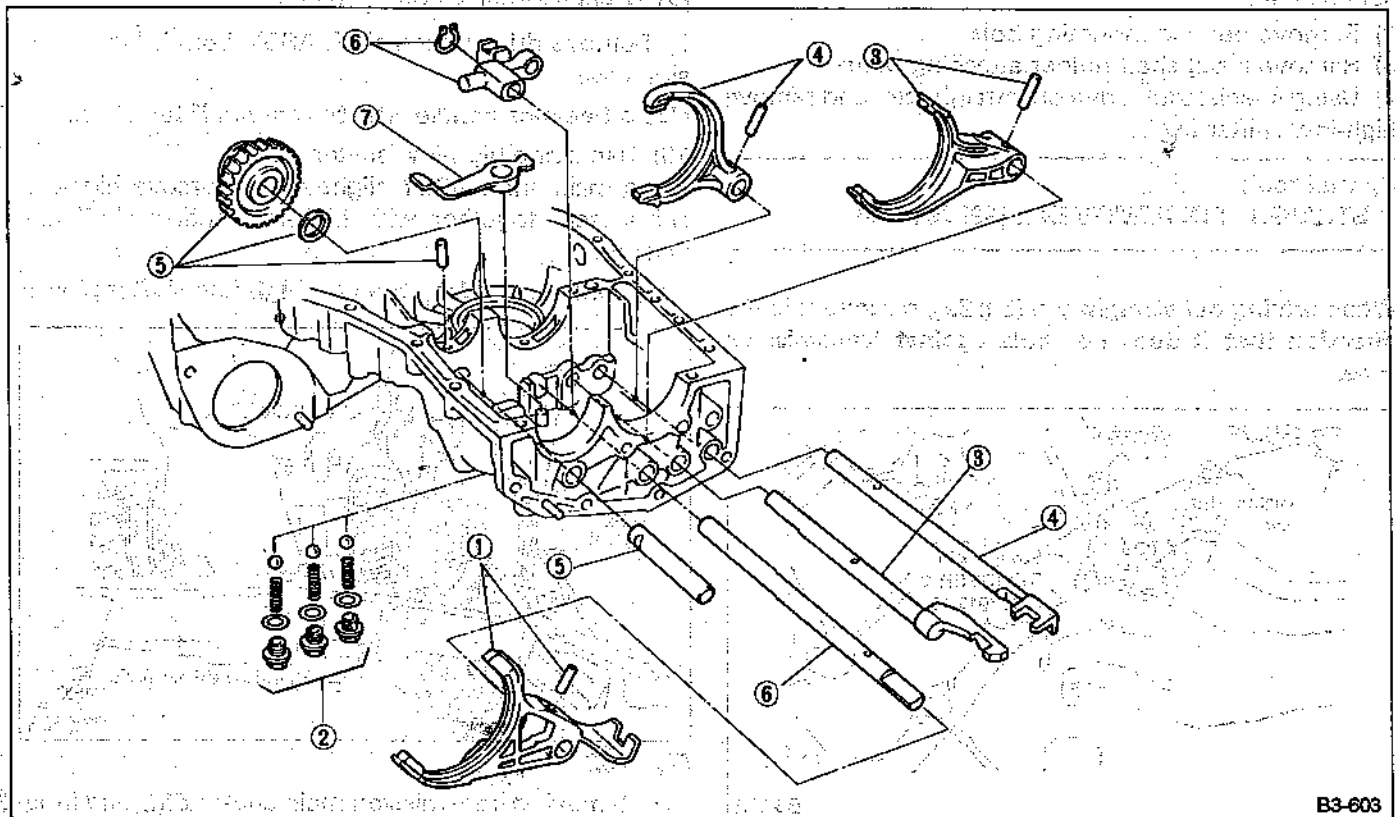


Fig. 103

(2) Separate main shaft ASSY and input shaft ASSY. Make sure that needle bearing is inserted in input shaft. Also, keep high and low balk ring.

- 12) Remove differential ASSY.
 - a. Be careful not to confuse right and left roller bearing outer races.
 - b. Be careful not to damage retainer oil seal.

2. TRANSMISSION CASE (Left-hand)



B3-603

Fig. 104

1) Drive out spring pin, and remove 5th shifter fork.

7) Remove reverse shifter lever.

Special tool:

— STRAIGHT PIN REMOVER 2: 398791700

8) Remove differential side retainers.

2) Remove plugs, springs and checking balls.

3) Drive out spring pin, and pull out 3-4 fork rod and shifter fork.

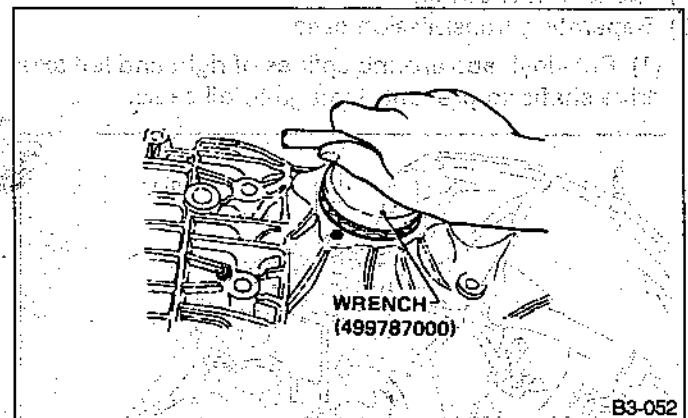
When removing rod, keep other rods in neutral. Also, when pulling out spring pin, remove it toward inside of case so that it may not hit against case.

4) Drive out spring pin, and pull out 1-2 fork-rod and shifter fork.

5) Pull out straight pin, and remove idler gear shaft, reverse idler gear and washer.

6) Remove outer snap ring, and pull out reverse shifter rod arm from reverse fork rod. Then take out ball, spring and interlock plunger from rod. And then remove rod.

When pulling out reverse shifter rod arm, be careful not to let ball pop out of arm.

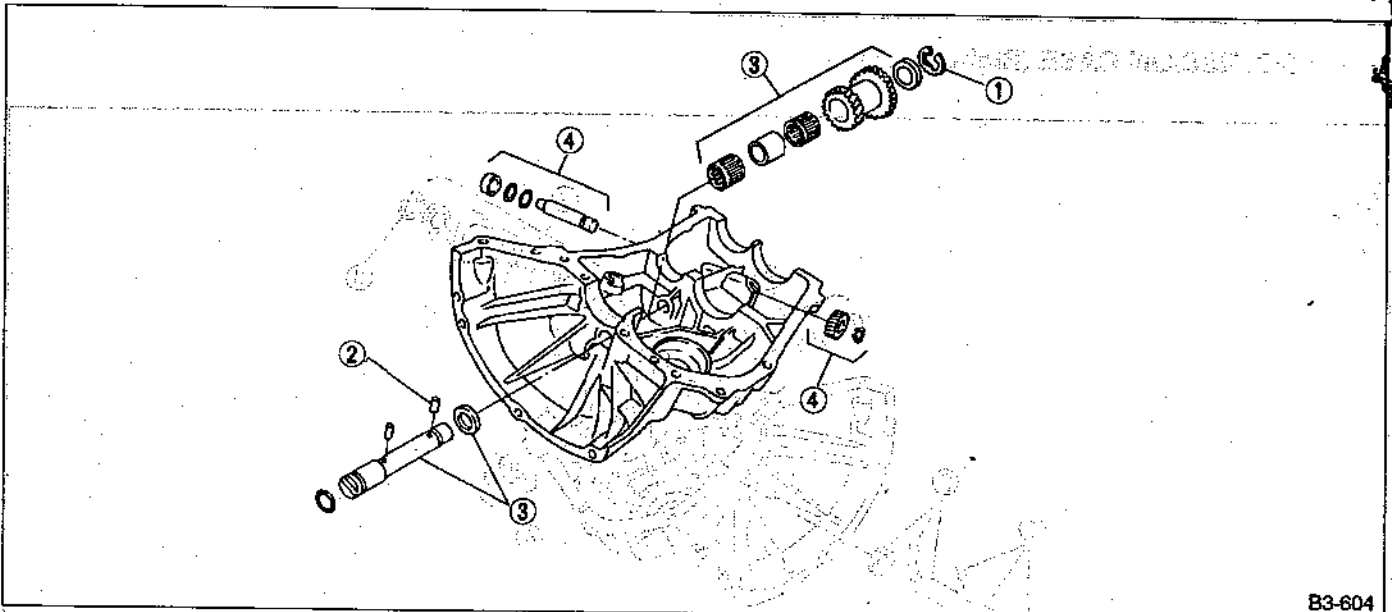


B3-052

Fig. 105

3. TRANSMISSION CASE (Right-hand)

8



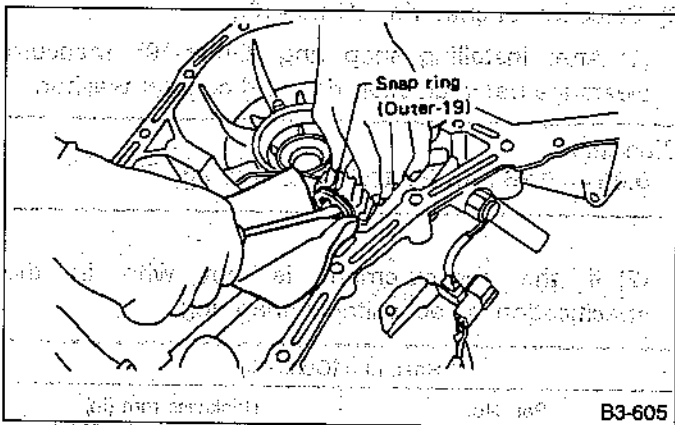
B3-604

Fig. 106

1) Move counter gear shaft until it touches transmission case, and remove snap ring (Outer-19) with a suitable tool.

3) Remove counter shaft from transmission case, taking care not to drop counter gear and two washers.

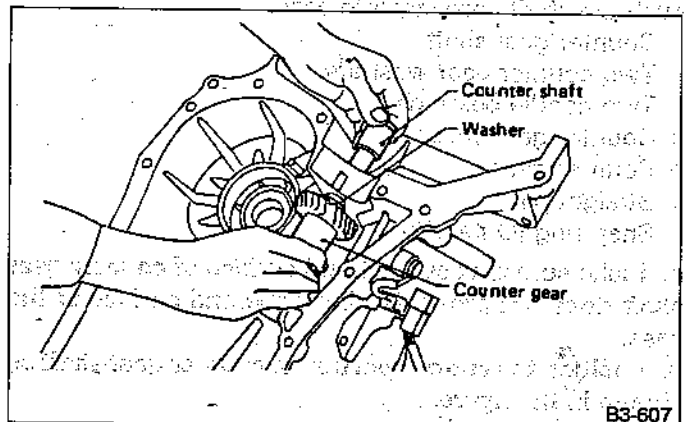
- a. Be careful not to damage O-ring.
- b. Be careful not to drop straight pin on front side.
- b. Be careful not to drop two needle bearings (22 x 28 x 23) and collar contained in counter gear.



B3-605

Fig. 107

2) Slide washer at rear of high-low counter shaft, and remove straight pin from counter shaft.

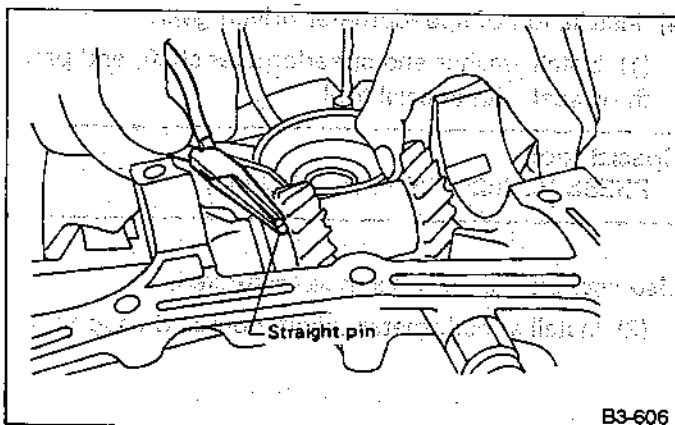


B3-607

Fig. 109

4) Remove outer snap ring and pull out speedometer driven gear. Next, remove speedometer shaft and washer.

5) Remove differential side retainer.



B3-606

Fig. 108

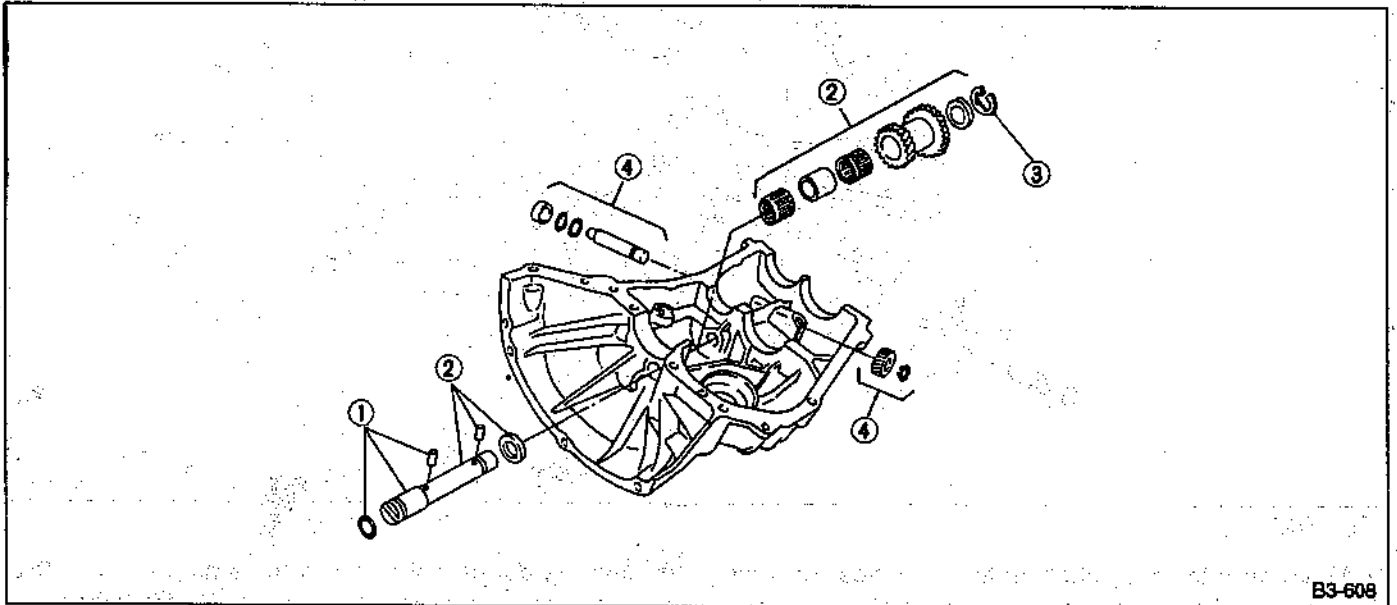
B: ASSEMBLY**1, TRANSMISSION CASE (Right-hand)**

Fig. 110

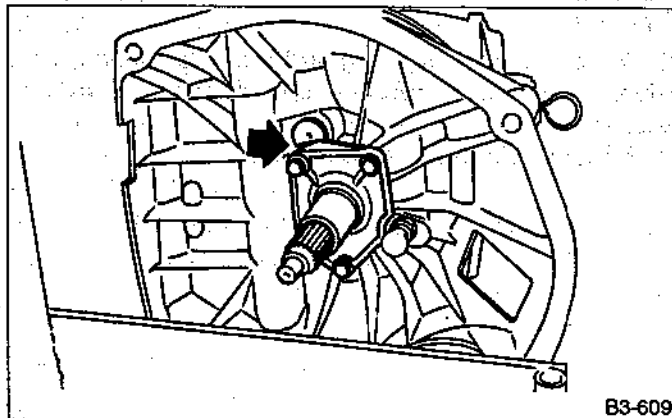
1) Install O-ring and straight pin onto counter gear shaft.

2) Install the following parts in main case (RH), and push the shaft perfectly into case.

- Counter gear shaft
- Two counter gear washers
- Two needle bearings
- Counter gear collar
- Counter gear
- Straight pin
- Snap ring (Outer-19)

a. Make sure that cut-out end surface of counter gear shaft does not protrude above the end surface of the case.

b. Position the cut-out portion of counter gear shaft as shown in the figure.



B3-609

Fig. 111

3) Selection of snap ring (Outer-19).

(1) After installing snap ring (Outer-19), measure clearance between snap ring and counter washer.

Clearance:

0.05 — 0.35 mm (0.0020 — 0.0138 in)

(2) If the measurement is not within the specification, select suitable snap ring.

Snap ring (Outer-19)	
Part No.	Thickness mm (in)
031319000	1.50 (0.0591)
805019010	1.72 (0.0677)

4) Installation of speedometer driven gear.

(1) Install washer and speedometer shaft, and press fit oil seal with special tool.

Special tool:

PRESS (899824100) or (499827000)

Use new oil seal, if it has been removed.

(2) Install speedometer driven gear and snap ring.

2. TRANSMISSION CASE (Left-hand)

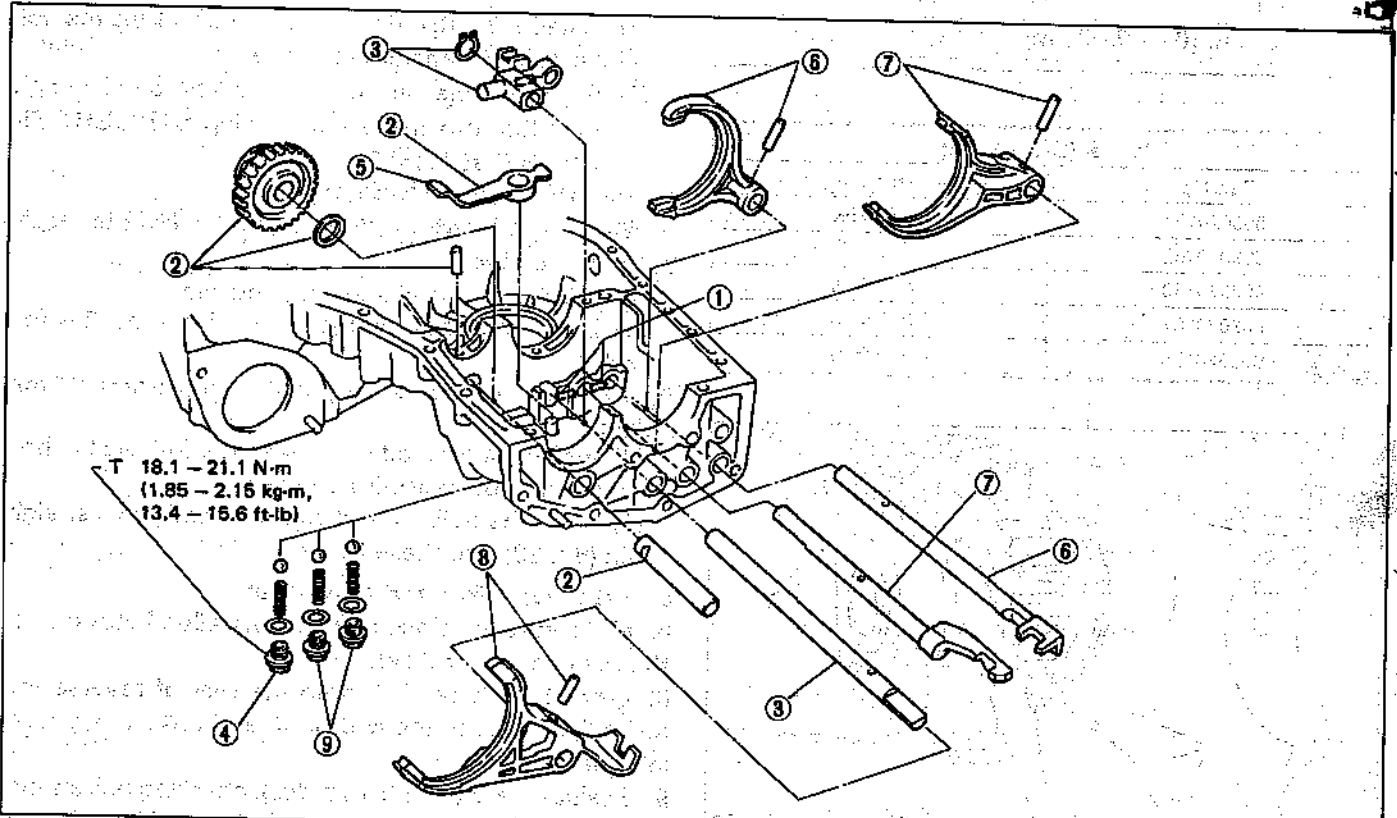


Fig. 112

B3-820

- 1) Position interlock plungers (5.56 x 19.6), one plunger in hole between 1-2 and 3-4 fork rod holes, and one plunger in hole between 3-4 and reverse fork rod holes.
- 2) Install reverse shifter lever, reverse idler gear and reverse idler gear shaft, and secure with straight pin. **Be sure to install reverse idler shaft from the rear side.**
- 3) Install reverse arm fork spring, ball and interlock plunger (5.56 x 19.6) to reverse fork rod arm. Insert reverse fork rod into hole in reverse fork rod arm, and hold it with outer snap ring using special tool.

Apply grease to plunger to prevent it from falling.

Special tool:

ACCENT BALL INSTALLER (399411700)

- 4) Position ball (7.1438), spring and gasket in reverse shifter rod hole, on L.H. transmission case, and tighten checking ball plug.

Replace gasket with a new one.

5) Adjustment of reverse idler gear position.

- (1) Move reverse shifter rod toward REV side. Adjust clearance between reverse idler gear and transmission case wall, using reverse shifter lever.

Clearance:

6.0 - 7.5 mm (0.236 - 0.295 in)

Reverse shifter lever		
Part No.	No.	Remarks
32820AA000	0	Further from case wall.
32820AA010	—	Standard.
32820AA020	2	Closer to case wall.

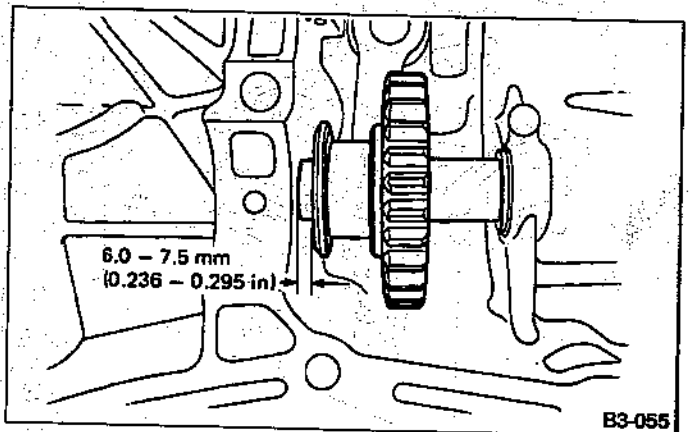


Fig. 113

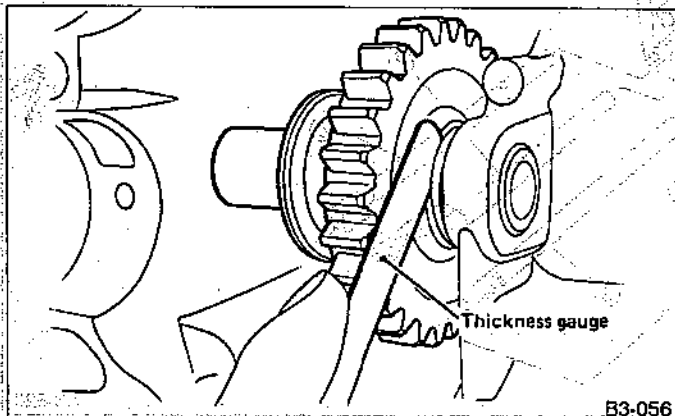
B3-055

- (2) After installing a suitable reverse shifter lever, shift into Neutral. Adjust clearance between reverse idler gear and transmission case wall, using reverse shifter lever(s).

Clearance:

0 — 0.5 mm (0 — 0.020 in)

Washer (20.5 x 26 x t)	
Part No.	Thickness mm (in)
803020151	0.4 (0.016)
803020152	1.1 (0.043)
803020153	1.5 (0.059)
803020154	1.9 (0.075)
803020155	2.3 (0.091)



B3-056

Fig. 114

3. COMBINATION OF TRANSMISSION CASE

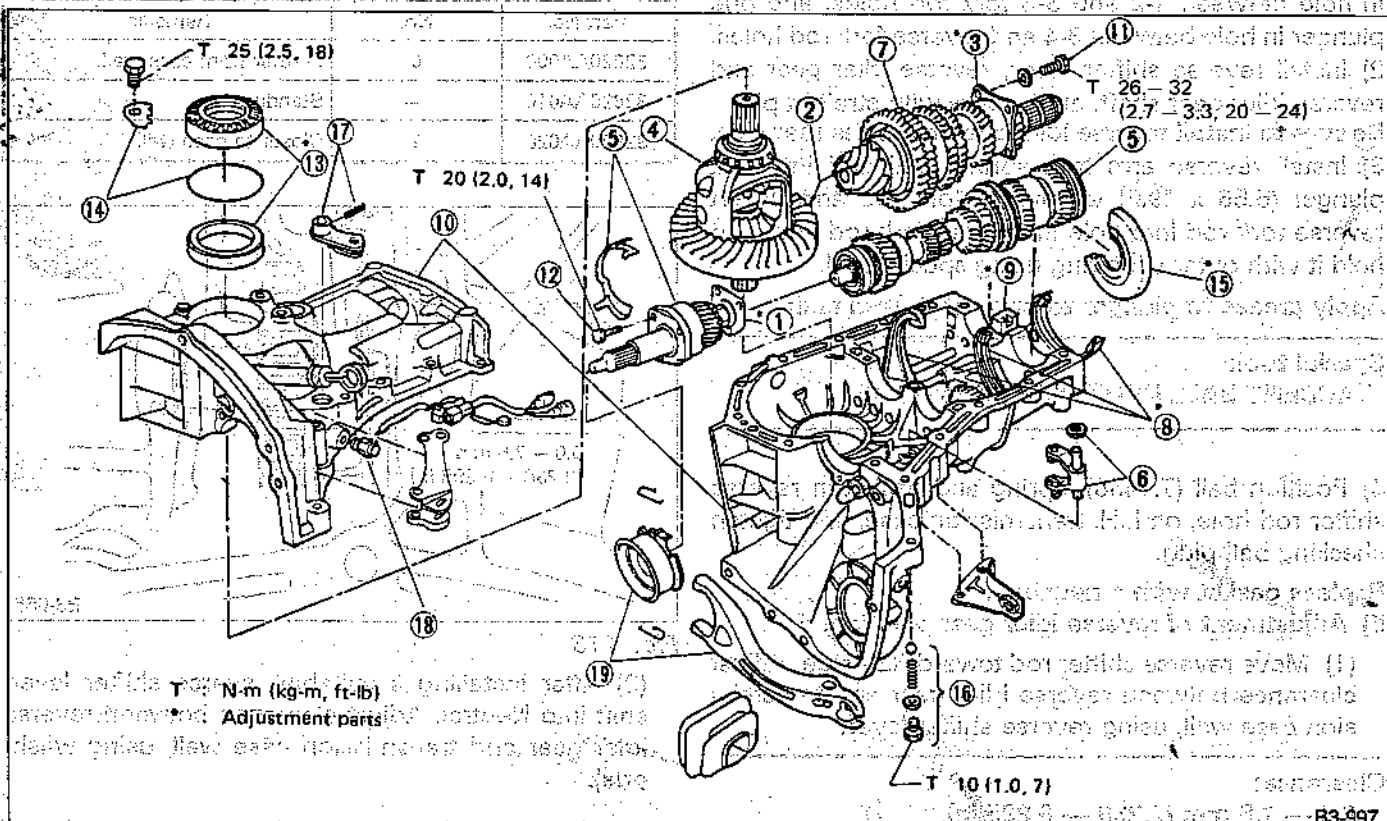


Fig. 115

6) Installation of 1-2 shifter fork and rod.

- (1) Install 1-2 fork rod into 1-2 shifter fork via the hole on the rear of transmission case.
- (2) Align the holes in rod and fork, and drive straight pin (6 x 22) into these holes using STRAIGHT PIN REMOVER (398791600).

a. Set other rods to Neutral.

b. Make sure interlock plunger (5.56 x 19.6) is on the 3-4 fork rod side.

7) Installation of 3-4 shifter fork and rod.

- (1) Install interlock plunger (3 x 11.9) onto 3-4 fork rod.

Apply a coat of grease to plunger to prevent it from falling.

- (2) Install 3-4 fork rod into 3-4 shifter fork via the hole on the rear of transmission case.

- (3) Align the holes in rod and fork, and drive straight pin (6 x 22) into these holes.

a. Set reverse fork rod to Neutral.

b. Make sure interlock plunger (installed before) is on the reverse fork rod side.

- 8) Install 5th shifter fork onto the rear of reverse fork rod. Align holes in the two parts and drive straight pin into place.

- 9) Position balls (7:1438 mm dia.), checking ball springs and gaskets into 3-4 and 1-2 rod holes, and install plugs. Replace gasket with a new one.

1) Adjustment of input shaft holder shim

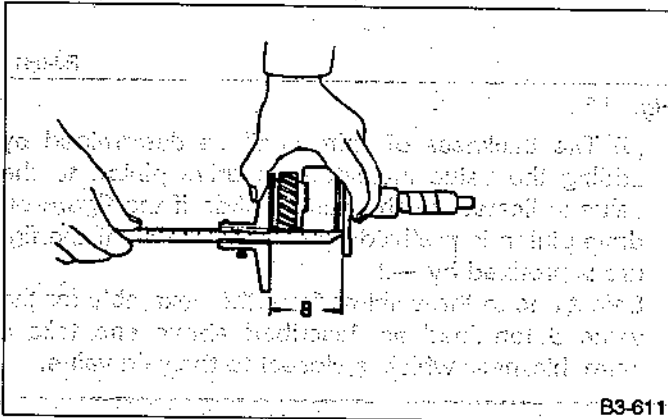
- (1) Place transmission main shaft ASSY and input shaft CP on transmission main case without shim.
- (2) The proper number of shim can be determined as follows:

$$D = A - (B + C)$$

- A: Main case length as shown in the figure.
A = 353 mm (13.90 in)
- B: Input shaft CP length as shown in the figure.
- C: Main shaft ASSY length as shown in the figure.

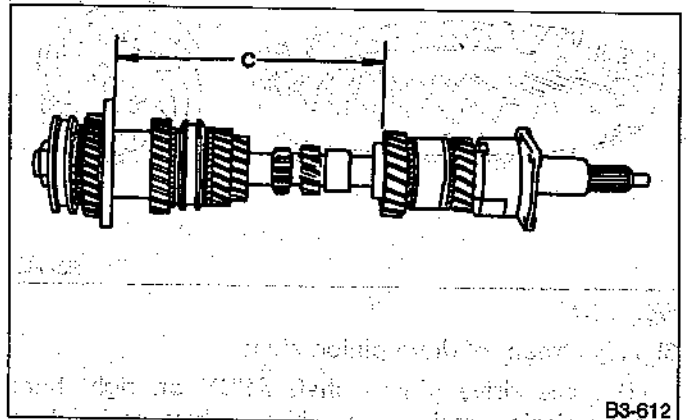
Dimension D mm (in)	No. of shims
52.46 — 53.23 (2.0654 — 2.0957)	—
51.96 — 52.45 (2.0457 — 2.0650)	1
51.34 — 51.95 (2.0213 — 2.0453)	2

The thickness of shim is 0.45 to 0.55 mm (0.0177 to 0.0217 in).



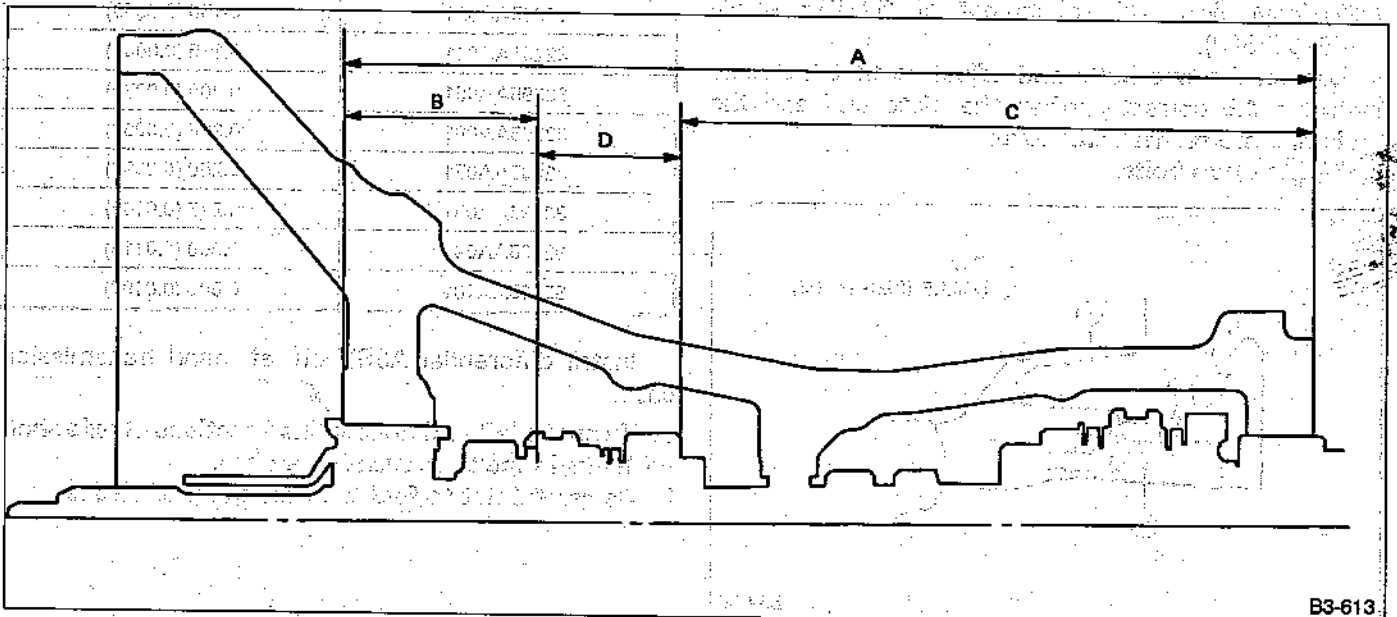
B3-611

Fig. 116



B3-612

Fig. 117



B3-613

Fig. 118

2) Alignment marks/figures on hypoid gear set

The upper figure on driven pinion is the match number for combining it with crown gear. The lower figure is for shim adjustment. If no lower figure is shown, the value is zero. The figure on crown gear indicates a number for combination with drive pinion.

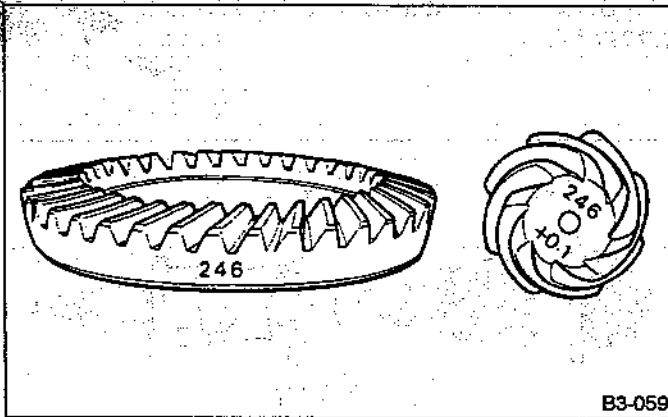


Fig. 119

3) Adjustment of drive pinion shim

(1) Place drive pinion shaft ASSY on right hand transmission main case without shim and tighten bearing mounting bolts.

(2) Inspection and adjustment of GAUGE ASSY (499917500).

a. Loosen the two bolts and adjust so that the scale indicates 0.5 correctly when the plate end and the scale end are on the same level.

b. Tighten two bolts.

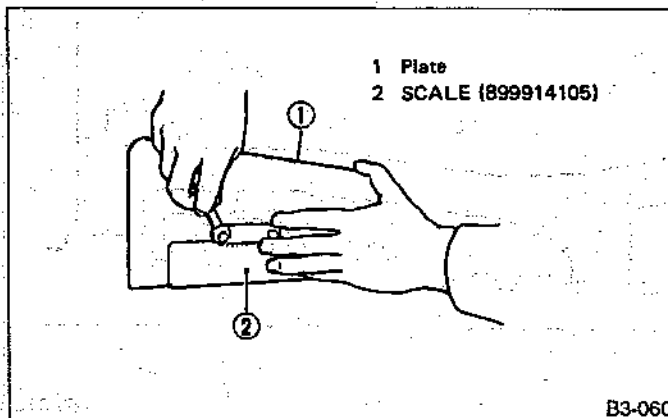


Fig. 120

(3) Position the gauge by inserting the knock pin of gauge into the knock hole in the transmission case.

(4) Slide the drive pinion gauge scale with finger tip and read the value at the point where it matches with the end face of drive pinion.

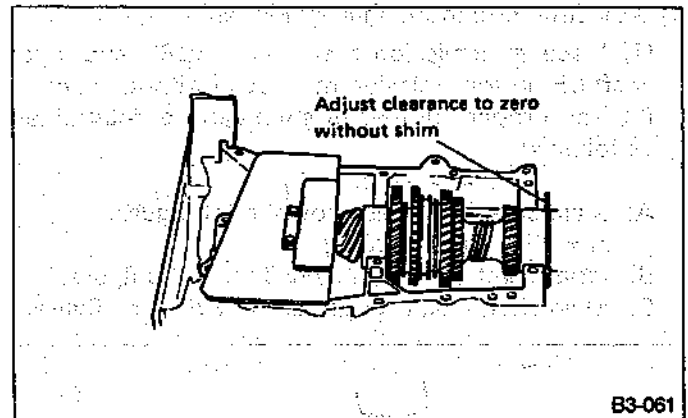


Fig. 121

(5) The thickness of shim shall be determined by adding the value indicated on drive pinion to the value indicated on the gauge. (Add if the figure on drive pinion is prefixed by + and subtract if the figure is prefixed by —.)

Select one to three shims from the next table for the value determined as described above and take a shim thickness which is closest to the said value.

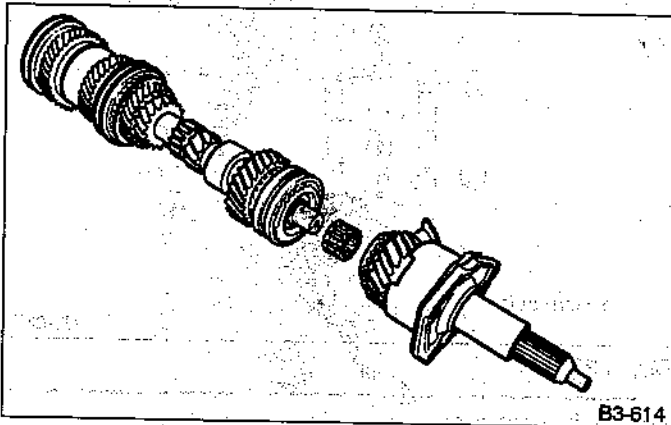
Drive pinion shim	
Part No.	Thickness mm (in)
32295AA031	0.150 (0.0059)
32295AA041	0.175 (0.0069)
32295AA051	0.200 (0.0079)
32295AA061	0.225 (0.0089)
32295AA071	0.250 (0.0098)
32295AA081	0.275 (0.0108)
32295AA091	0.300 (0.0118)
32295AA101	0.500 (0.0197)

4) Install differential ASSY on left hand transmission case.

a. Wrap the left and right splined sections of axle shaft with vinyl tape to prevent scratches.

b. Be careful not to fold the sealing lip of oil seal.

5) Put main shaft ASSY, needle bearing, high-low synchronizer ring, oil guide and input shaft CP together.



B3-614

Fig. 122

a. When installing high-low synchronizer ring, align the ring groove and insert.

b. Be sure to install the input shaft holder shims (0 to 2 sheets) selected before.

6) Transmission main shaft ASSY

(1) Install high-low shifter fork and two high-low shifter pieces as a unit onto high-low shifter sleeve.

(2) Raise transmission main shaft ASSY slightly and turn it 90° over the transmission.

(3) With transmission main shaft ASSY held in that position, insert high-low shifter shaft into hole in LH transmission case.

(4) Install washer onto high-low shifter shaft.

a. Be careful not to separate input shaft CP from main shaft ASSY.

b. Make sure that oil guide is positioned in the groove of main case (LH).

c. Be sure straight pin is positioned in the hole of needle bearing.

d. Apply a coat of gear oil to the nylon tip of fork.

e. Face the cutout section of circlip on the bearing outer race (rear end of main shaft) toward the drive pinion shaft.

7) Install drive pinion shaft ASSY with shims selected before into transmission case.

Ensure that the knock pin of the case is fitted into the hole in the bearing outer race.

8) Selection of suitable 1st-2nd, 3rd-4th and 5th shifter fork CP's.

Set transmission main shaft ASSY and drive pinion shaft ASSY in position (so there is no clearance between the two when moved all the way to the front). Select suitable 1st-2nd, 3rd-4th and 5th shifter fork CP's so that coupling sleeve and reverse driven gear are positioned in the center of their synchronizing mechanisms.

1st-2nd shifter fork CP			3rd-4th shifter fork CP			5th shifter fork CP		
Part No.	No.	Remarks	Part No.	No.	Remarks	Part No.	No.	Remarks
32804AA060	1	Moves 0.2 mm (0.008 in) closer to 1st gear	32810AA060	1	Moves 0.2 mm (0.008 in) closer to 4th gear	32812AA060	1	Moves 0.2 mm (0.008 in) closer to 5th gear
32804AA070	—	Positions in the center	32810AA070	—	Positions in the center	32812AA070	—	Positions in the center
32804AA080	3	Moves 0.2 mm (0.008 in) closer to 2nd gear	32810AA100	3	Moves 0.2 mm (0.008 in) closer to 3rd gear	32812AA100	3	Moves 0.2 mm (0.008 in) further from 5th gear

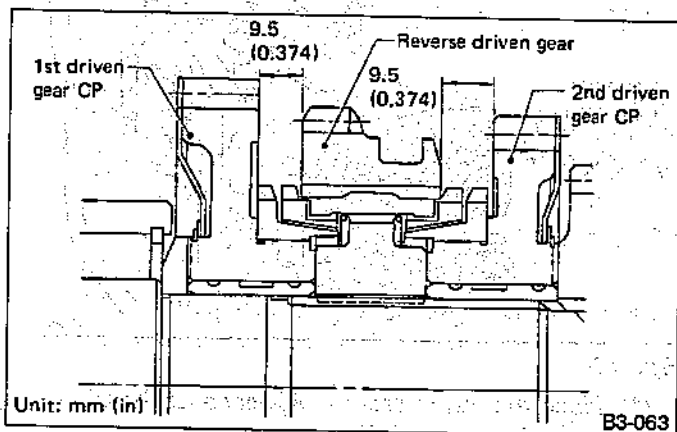


Fig. 123

B3-063

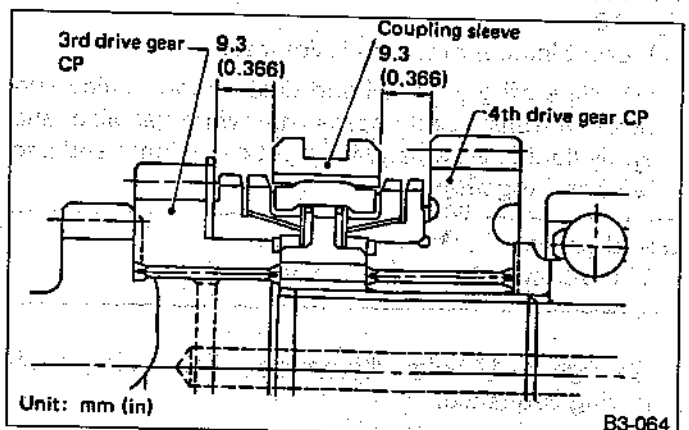


Fig. 124

B3-064

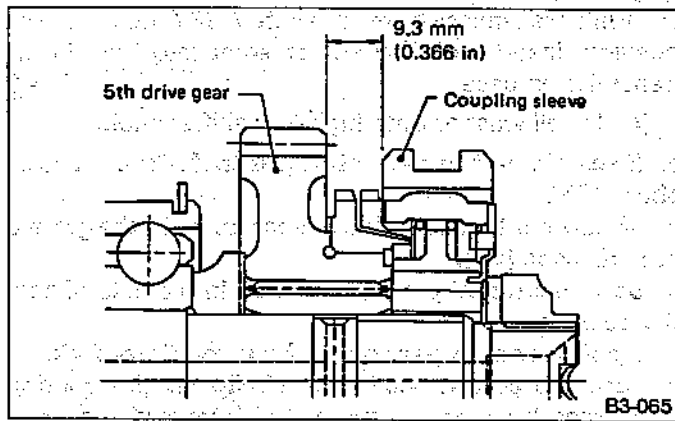


Fig. 125

9) Inspection of rod end clearance. Measure rod end clearances A and B. If any clearance is not within specifications, replace rod or fork as required.

A: 1st-2nd to 3rd-4th	0.5 — 1.5 mm (0.020 — 0.059 in)
B: 3rd-4th to 5th	0.6 — 1.4 mm (0.024 — 0.055 in)

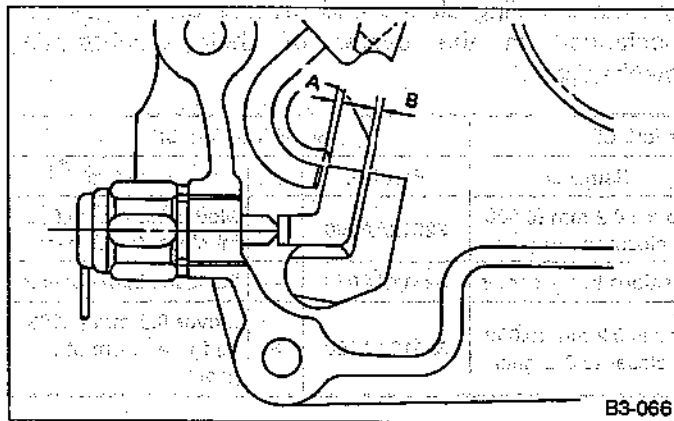


Fig. 126

10) Combination of transmission case.

(1) Wipe off grease, oil and dust on the mating surfaces of transmission cases with white gasoline, and apply liquid gasket, and then put case right hand and left hand together.

Liquid gasket:

Three-bond 1215 or equivalent

(2) Tighten 17 bolts with bracket, clip, etc. in the following sequence.

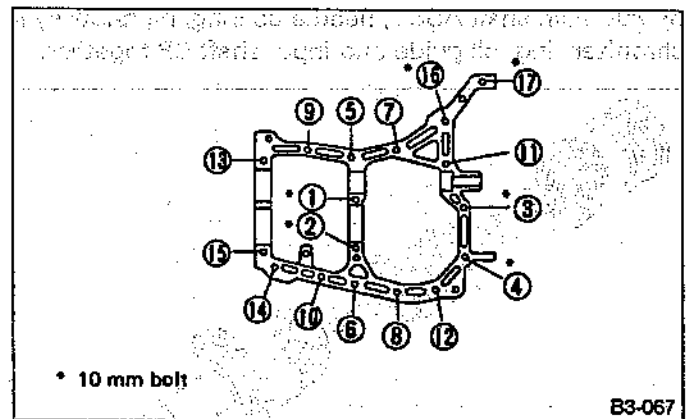


Fig. 127

Tightening torque:

8 mm bolt

23 — 26 N·m (2.3 — 2.7 kg-m, 17 — 20 ft-lb)

10 mm bolt

36 — 42 N·m (3.7 — 4.3 kg-m, 27 — 31 ft-lb)

a. Insert bolts from the bottom and tighten nuts at the top.

b. Put cases together so that drive pinion shim and input shaft holder shim are not caught up in between.

c. Confirm that counter gear and speedometer gear are meshed, and high-low shifter shaft is inserted perfectly.

11) Tighten ball bearing attachment bolts.

12) Install input shaft holder attaching bolts.

13) Backlash adjustment of hypoid gear and preload adjustment of roller bearing.

Support drive pinion ASSY with special tool. [Full-time 4WD only]

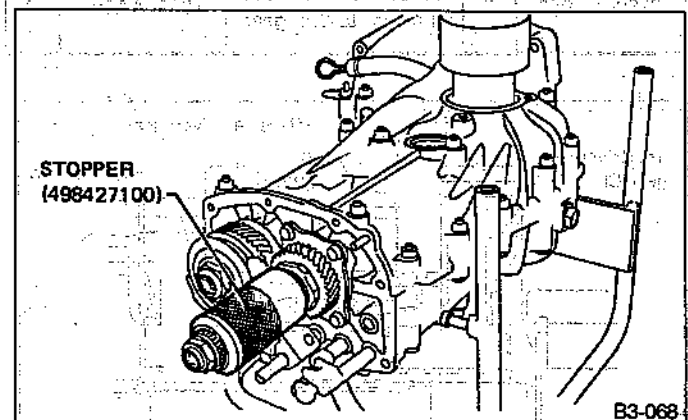


Fig. 128

(1) Place the transmission with case left hand facing downward and put WEIGHT on bearing cup.

(2) Screw retainer ASSY into case left hand from the bottom with WRENCH. Fit HANDLE on the transmission main shaft. Shift gear into 4th or 5th and turn the shaft several times. Screw in the retainer while turn

ing HANDLE until a slight resistance is felt on WRENCH.

This is the contact point of hypoid gear and drive pinion shaft. Repeat the above sequence several times to ensure the contact point.

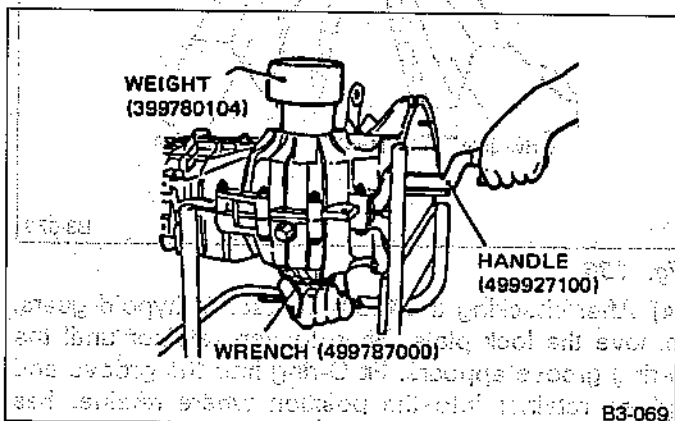


Fig. 129

(3) Remove weight and screw in retainer without O-ring on the upper side and stop at the point where slight resistance is felt.

At this point, the backlash between the hypoid gear and drive pinion shaft is zero.

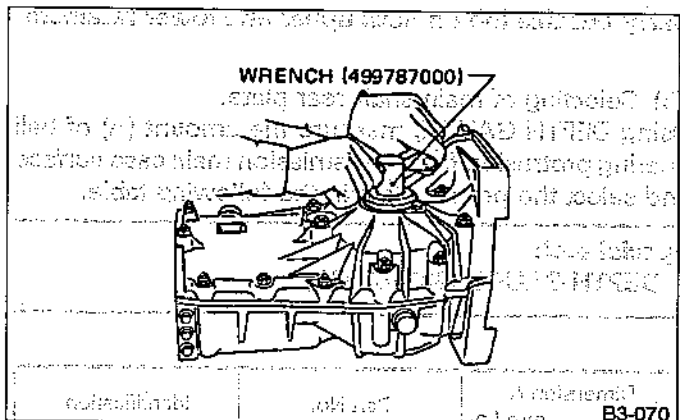


Fig. 130

(4) Fit lock plate. Loosen the retainer on the lower side by 1-1/2 notches of lock plate and turn in the retainer on the upper side by the same amount in order to obtain the backlash.

The notch on the lock plate moves by 1/2 notch if the plate is turned upside down.

(5) Turn in the retainer on the upper side additionally by 1 notch in order to apply preload on taper roller bearing.

(6) Tighten temporarily both the upper and lower lock plates and mark both holder and lock plate for later readjustment.

(7) Turn transmission main shaft dozens of turns while tapping around retainer lightly with plastic hammer.

(8) Set DIAL GAUGE and MAGNET BASE. Insert the needle through transmission oil drain plug hole so that the needle comes in contact with the tooth surface at a right angle and check the backlash.

Backlash:

0.13 — 0.18 mm (0.0051 — 0.0071 in)

a) If backlash outside specified range, adjust it by turning holder in RH case.

b) Turning holder pawl 1/2 rotation changes backlash by approximately 0.04 mm (0.0016 in).

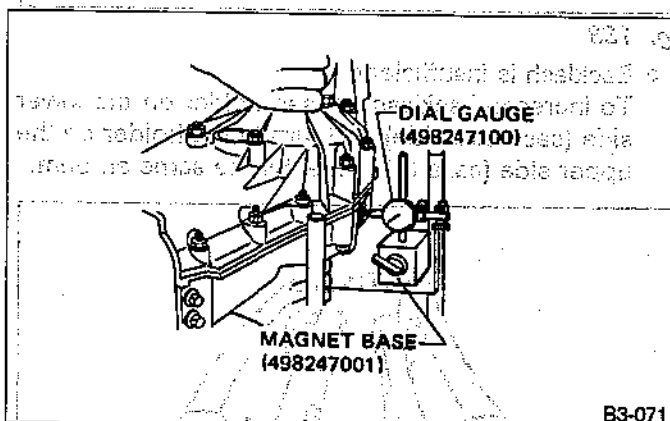


Fig. 131

(9) Check tooth contact of hypoid gear as follows: Apply a uniform thin coat of red lead on both tooth surfaces of 3 or 4 teeth of the hypoid gear. Move the hypoid gear back and forth by turning the transmission main shaft until a definite contact pattern is developed on hypoid gear, and judge whether face contact is correct. If it is incorrect, make the following correction.

- Tooth contact is correct.

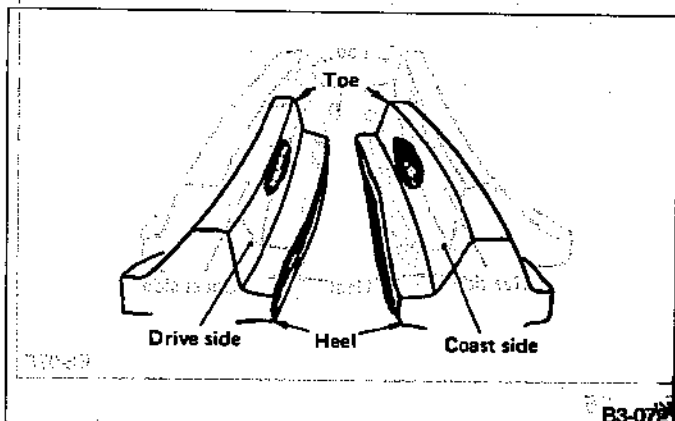


Fig. 132

- Backlash is excessive.

To reduce backlash, loosen holder on the upper side (case R.H. side) and turn in the holder on the lower side (case L.H. side) by the same amount.

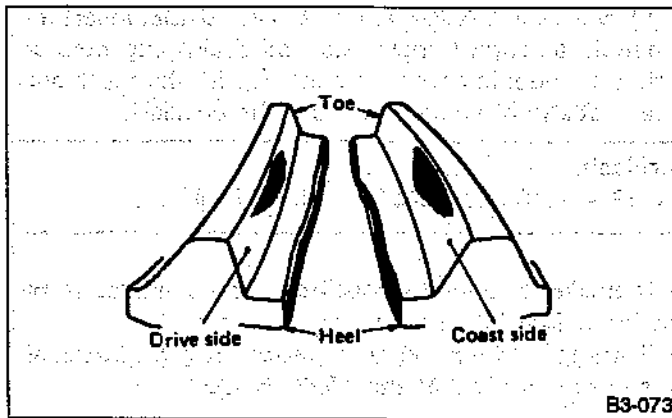


Fig. 133

- Backlash is insufficient.
To increase backlash, loosen holder on the lower side (case L.H. side) and turn in the holder on the upper side (case R.H. side) by the same amount.

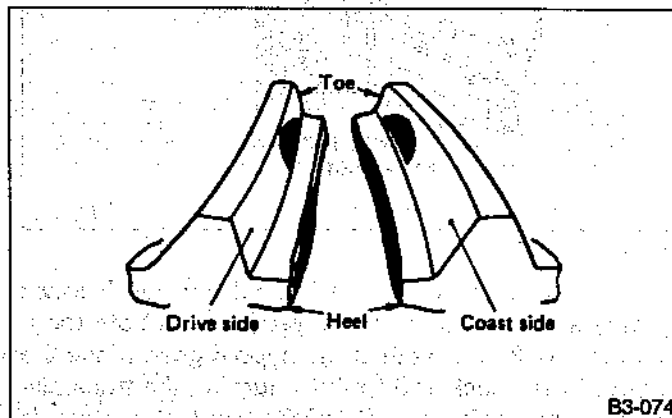


Fig. 134

- The drive pinion shim selected before is too thick.
Reduce its thickness.

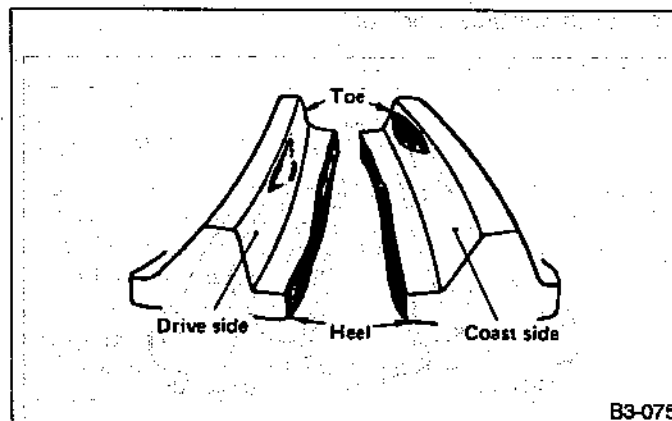


Fig. 135

- The drive pinion shim selected before is too thin.
Increase its thickness.

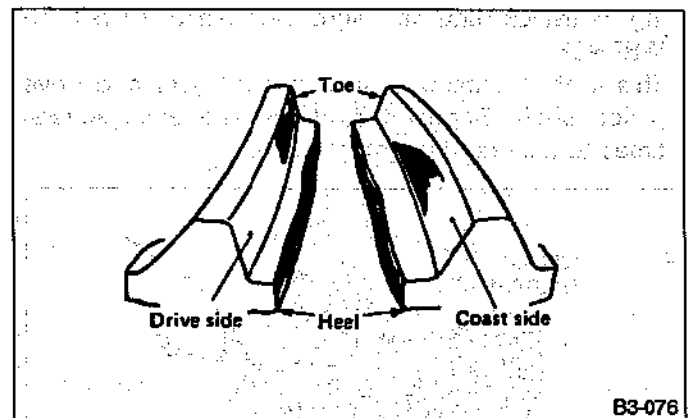


Fig. 136

- 14) After checking the tooth contact of hypoid gears, remove the lock plate. Then loosen retainer until the O-ring groove appears. Fit O-ring into the groove and tighten retainer into the position where retainer has been tightened in.
Tighten lock plate.

Tightening torque:

22 — 27 N·m

(2.2 — 2.8 kg-m, 16 — 20 ft-lb)

Carry out this job on both upper and lower retainers.

- 15) Selecting of main shaft rear plate.
Using DEPTH GAUGE, measure the amount (A) of ball bearing protrusion from transmission main case surface and select the proper plate in the following table.

Special tool:**DEPTH GAUGE (498147000)**

Dimension A mm (in)	Part No.	Identification
4.0 — 4.13 (0.1575 — 0.1626)	32294AA040	1
3.87 — 3.99 (0.1524 — 0.1571)	32294AA050	2

Before measuring, tap the end of main shaft by the plastic hammer lightly in order to make the clearance zero between the main case surface and the moving flange of bearing.

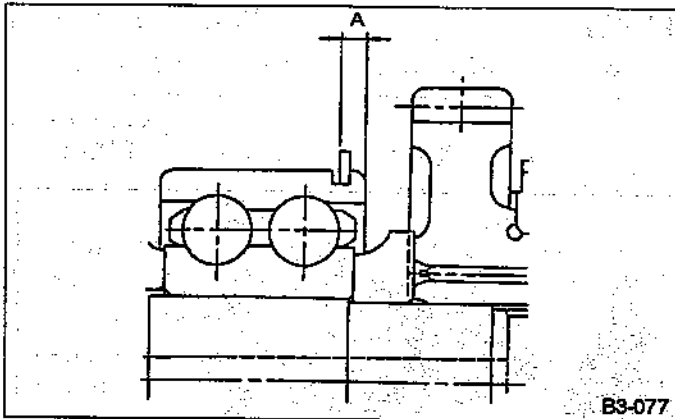


Fig. 137

- 16) Install ball, checking ball spring and gasket in transmission case and tighten plug.
- 17) Install high-low shifter lever CP onto high-low shifter shaft extending from RH transmission case, and secure with straight pin (6 x 22).
- Pay attention to the direction of high-low shifter lever CP when installing.**
- 18) Install low switch.
- 19) Install clutch release lever and bearing.

Snap ring (Outer-25)	
Part No.	Thickness mm (in)
805025058	2.37 (0.0933)
805025051	2.42 (0.0953)
805025052	2.47 (0.0972)
805025053	2.52 (0.0992)
805025054	2.57 (0.1012)
805025055	2.62 (0.1031)
805025056	2.67 (0.1051)
805025057	2.72 (0.1071)

- 4th needle bearing inner race
- 3rd drive gear CP
- 3rd-4th synchronizing

Special tool:
**TRANSMISSION MAIN SHAFT
 REMOVER (899864100)**
REMOVER (899714110)

Replace sleeve and hub with new ones. Do not attempt to disassemble because they must engage at a specified point. If they should be disassemble, mark engagement point on splines beforehand.

Special tool:
SNAP RING PRESS (499757002)
SNAP RING GUIDE (499757001)

B: ASSEMBLY

- 1) Assemble sleeve & hub ASSY for 3rd-4th, 5th and high-low synchronizing.

14. Main Shaft ASSY (4WD Single-range and 2000-2200cc FWD)

A: DISASSEMBLY

- 1) Put vinyl tape around main shaft splines to protect oil seal from damage. Then pull out oil seal and needle bearing by hand.
- 2) Remove locknut.

Remove caulking before taking off locknut.

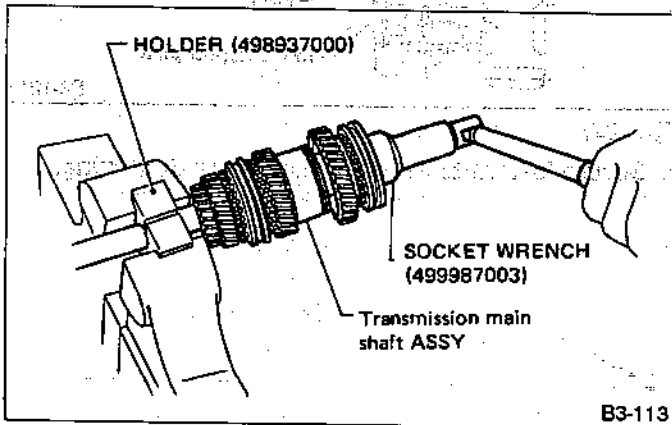


Fig. 236

- 3) Remove insert stopper plate, sleeve and hub ASSY No. 2, balk ring, 5th drive gear CP, and needle bearing (32 x 36 x 25.7).

- 4) Using special tool and a press, remove:

- 5th needle bearing inner race
- 5th gear thrust washer
- Ball bearing (25.5 x 65 x 31)
- 4th gear thrust washer
- 4th drive gear CP
- Sleeve and hub assembly
- Balk ring
- 4th needle bearing

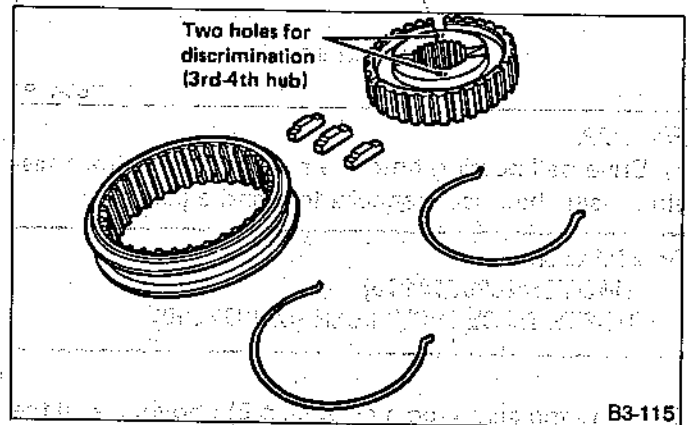


Fig. 237

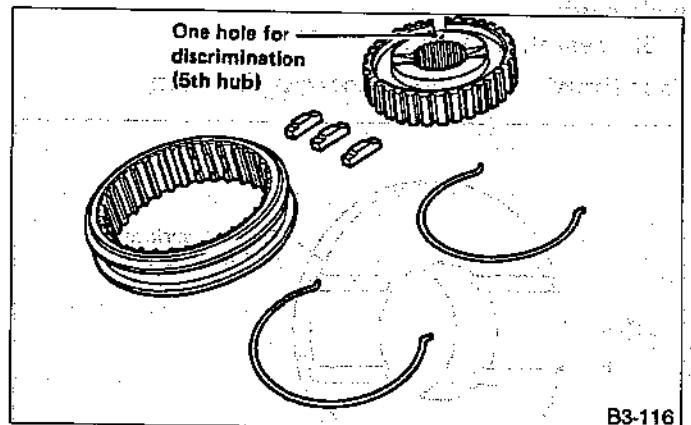


Fig. 238

Position open ends of spring 120° apart.

- 2) Install 3rd drive gear CP, balk ring, and sleeve & hub ASSY for 3rd-4th needle bearing (32 x 36 x 25.7) on transmission main shaft.

Align groove in balk ring with shifting insert.

- 3) Install 4th needle bearing race onto transmission main shaft using special tool and a press.

Special tool:

REMOVER (8997141100)
INSTALLER (499877000)

4) Install balk ring, needle bearing (32 x 30 x 25.7), 4th drive gear CP and 4th gear thrust washer to transmission main shaft.

Face thrust washer in the correct direction.

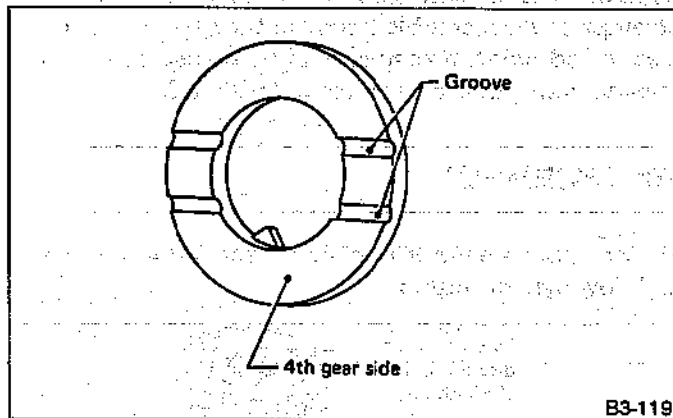


Fig. 239

5) Drive ball bearing onto the rear section of transmission main shaft using special tool and a press.

Special tool:

REMOVER (899714110)
4TH-5TH RACE INSTALLER (499877000)

6) Using the same tools as in step 5) above, install the following parts onto the rear section of transmission main shaft.

- 5th gear thrust washer

Face thrust washer in the correct direction.

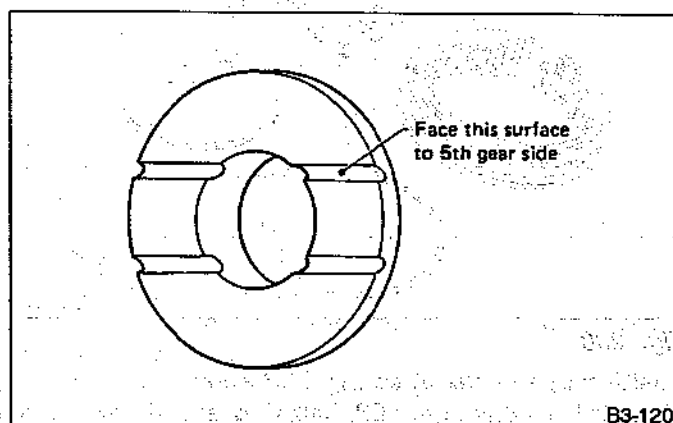


Fig. 240

- 5th needle bearing race

7) Install the following parts to the rear section of transmission main shaft.

- Needle bearing (32 x 36 x 25.7)
- 5th drive gear

- Balk ring
- Sleeve & hub ASSY
- Insert stopper plate
- Lock washer (22 x 38 x 2)
- Tighten lock nuts (22 x 13) to the specified torque using special tool.

Special tool:

SOCKET WRENCH (499987003)
TRANSMISSION MAIN SHAFT HOLDER (498937000)

- Align groove in balk ring with shifting insert.
- Be sure to fit pawl of insert stopper plate into 4 mm (0.16 in) dia. hole in the boss section of synchronizer hub.

Tightening torque:

112 — 124 N·m (11.4 — 12.6 kg-m, 82 — 91 ft-lb)

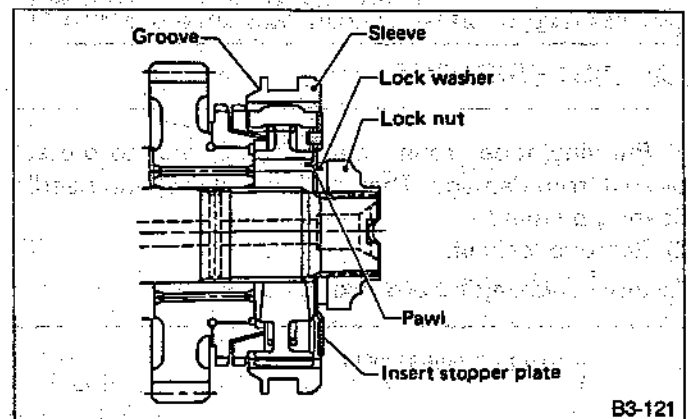


Fig. 241

- Secure lock nuts in two places after tightening.

16. Center Differential (Full-time 4WD)

A: DISASSEMBLY

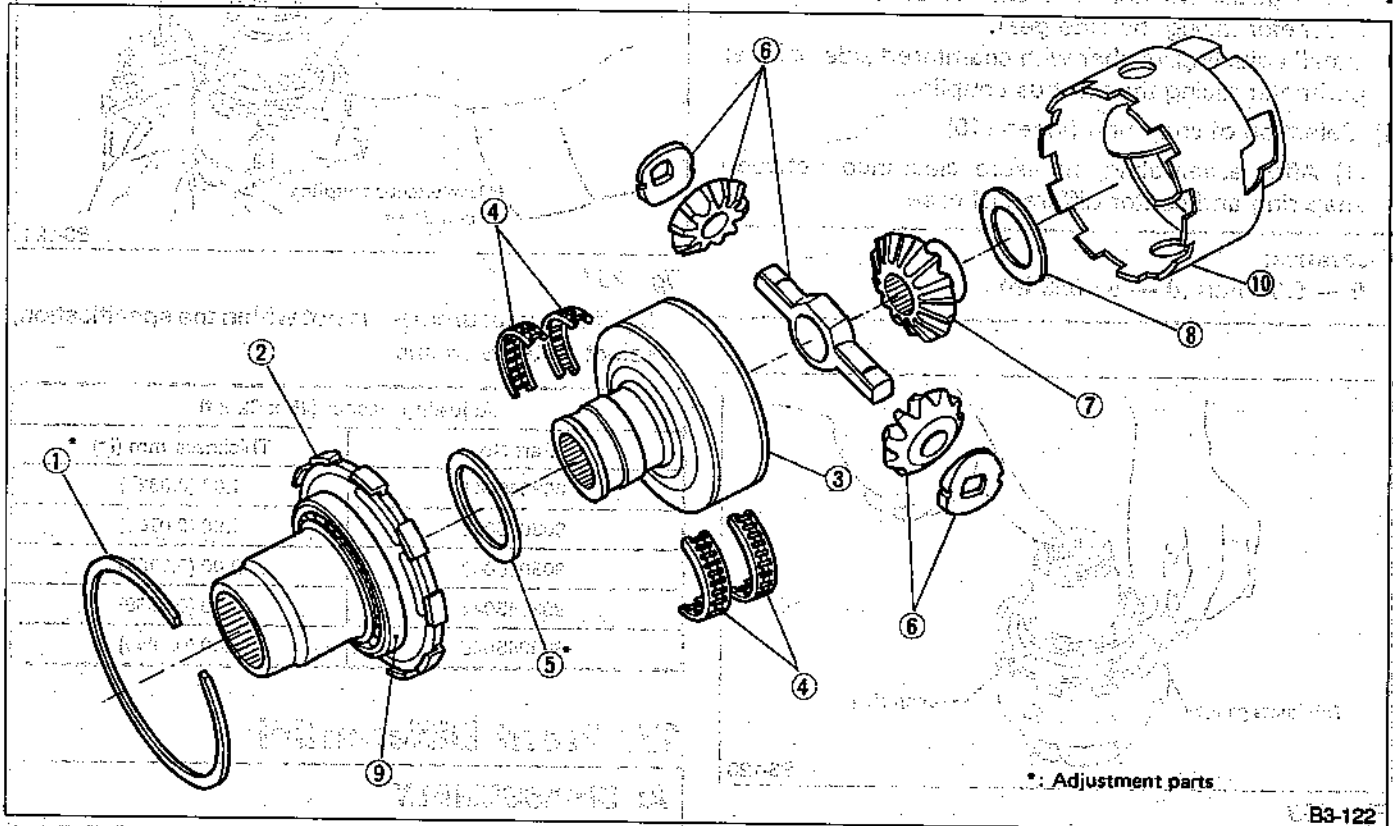


Fig. 251

- 1) Remove snap ring (inner-110) using flat bladed screw driver.
- 2) Remove center differential cover.
- 3) Remove viscous coupling.
- 4) Remove needle bearings.
- 5) Remove adjusting washer (45 x 62 x t).
- 6) Remove pinion shaft, bevel pinions and retainers.
- 7) Remove side gear.
- 8) Remove thrust washer.
- 9) Remove ball bearing.

Do not reuse roller bearing.

Special tool:

REMOVER (498077300)

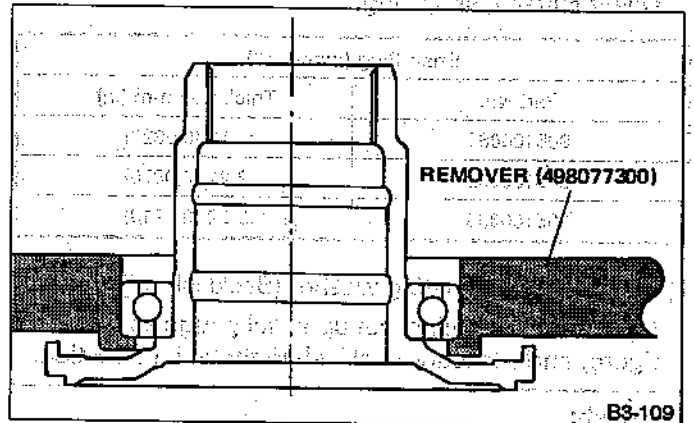


Fig. 252

B: ASSEMBLY

Assembly is in the reverse order of disassembly. Observe following;

- When assembling needle bearing (35 x 42 x press-fit the bearing together with a new viscous coupling washer using special tool.

- 10) Remove viscous coupling washer using pliers.
- Do not remove the washer except when replacing needle bearing in viscous coupling, because the washer must not be reused after removal.**

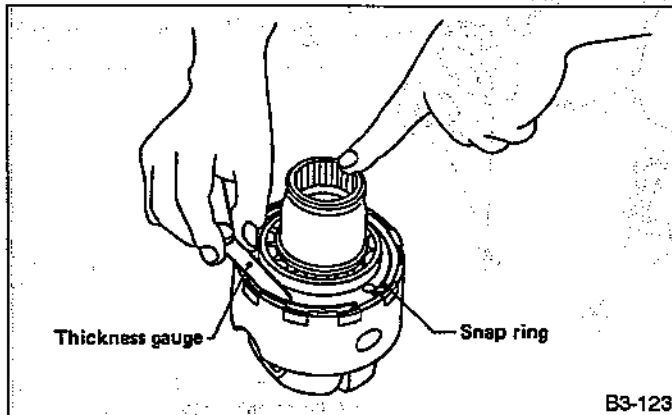
- 11) Take out needle bearing (35 x 42 x 12).

Special tool:
INSTALLER SET (499547300)

- Install thrust washer with chamfered side of inner perimeter facing the side gear.
- Install adjusting washer with chamfered side of inner perimeter facing the viscous coupling.

- 1) Selection of snap ring (Inner-110)
 (1) After assembling, measure clearance between snap ring and center differential case.

Clearance:
 0 — 0.15 mm (0 — 0.0059 in)



B3-123

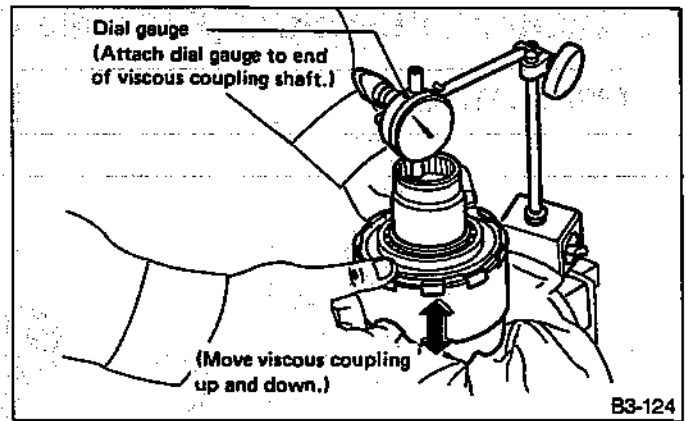
Fig. 253

- (2) If the measurement is not within the specification, select suitable snap ring.

Snap Ring (Inner-110)	
Part No.	Thickness mm (in)
805100061	2.10 (0.0827)
805100062	2.21 (0.0870)
805100063	2.32 (0.0913)

- 2) Selection of adjusting washer (Backlash adjustment)
 (1) After assembling, set up a dial gauge as shown in figure, and measure backlash in the axial direction.

Backlash:
 0.62 — 0.86 mm (0.0244 — 0.0339 in)



B3-124

Fig. 254

- (2) If the measurement is not within the specification, select suitable washer.

Adjusting washer (45 x 62 x t)	
Part No.	Thickness mm (in)
803045041	1.60 (0.0630)
803045042	1.80 (0.0709)
803045043	2.00 (0.0787)
803045044	2.20 (0.0866)
803045045	2.40 (0.0945)

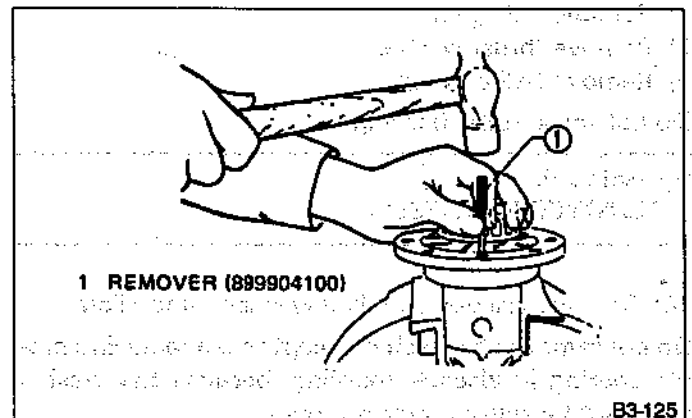
17. Front Differential

A: DISASSEMBLY

- 1) Remove right and left snap rings from differential, and then remove two axle drive shafts.

During reassembly, reinstall each axle drive shaft in the same place from which it was removed.

- 2) Loosen twelve bolts and remove hypoid drive gear.
 3) Drive out straight pin from differential ASSY toward crown gear.



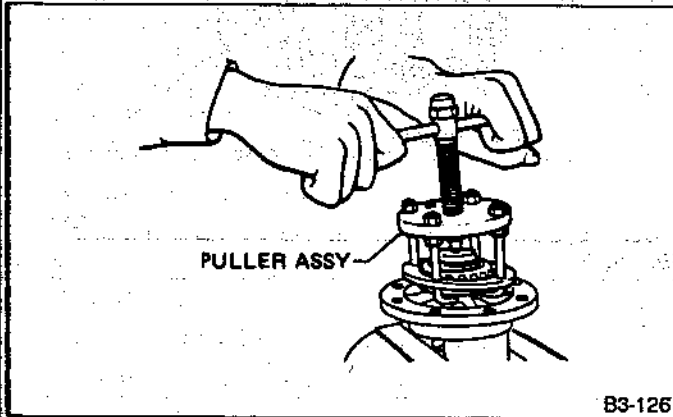
B3-125

Fig. 255

- 4) Pull out pinion shaft, and remove differential bevel pinion and gear and washer.
 5) Remove roller bearing.

Special tool:

[1600•1800cc FWD] PULLER ASSY (899524100)
 [Others] PULLER ASSY (399527700)



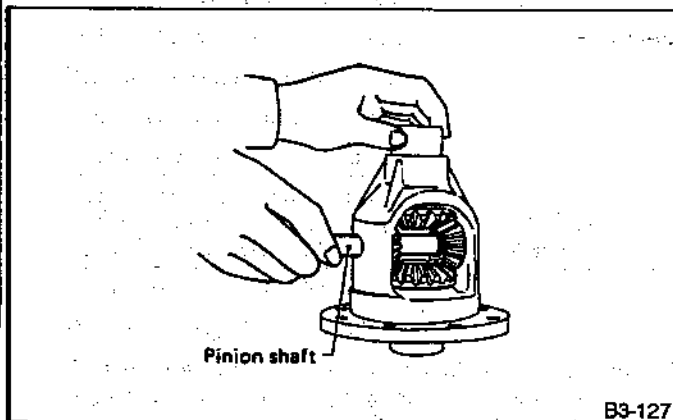
B3-126

Fig. 256

B: ASSEMBLY

1) Install bevel gear and bevel pinion together with washers, and insert pinion shaft.

Face the chamfered side of washer toward gear.



B3-127

Fig. 257

2) Measure backlash between bevel gear and pinion. If it is not within specifications, install a suitable washer to adjust it.

Standard backlash:

0.13 — 0.18 mm (0.0051 — 0.0071 in)

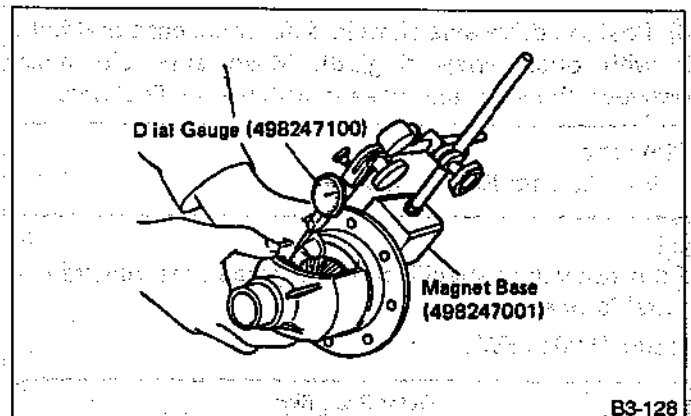
Be sure the pinion gear tooth contacts adjacent gear teeth during measurement.

•1600•1800cc FWD

Washer (35.1 x 45 x t mm)	
Part No.	Thickness mm (in)
803135011	0.925 — 0.950 (0.0364 — 0.0374)
803135012	0.950 — 0.975 (0.0374 — 0.0384)
803135013	0.975 — 1.000 (0.0384 — 0.0394)
803135014	1.000 — 1.025 (0.0394 — 0.0404)
803135015	1.025 — 1.050 (0.0404 — 0.0413)

•Others

Washer (38.1 x 50 x t)	
Part No.	Thickness mm (in)
803038021	0.925 — 0.950 (0.0364 — 0.0374)
803038022	0.975 — 1.000 (0.0384 — 0.0394)
803038023	1.025 — 1.050 (0.0404 — 0.0413)



B3-128

Fig. 258

3) Align pinion shaft and differential case at their holes, and drive straight pin into holes from the crown gear side, using STRAIGHT PIN REMOVER.

Lock straight pin after installing.

4) Install roller bearing (40 x 80 x 19.75) to differential case.

Be careful because roller bearing outer races are used as a set.

Special tool:

[1600•1800cc FWD]

- ① INSTALLER (399790110)
- ② SEAT (399520105)

[Others]

- ① INSTALLER (499277100)
- ② ADAPTER (398497701)

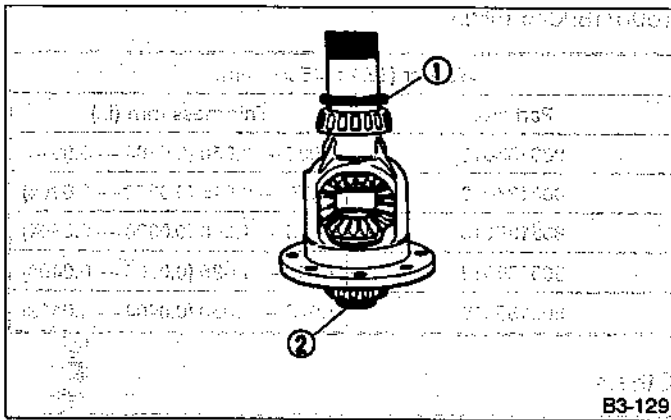


Fig. 259

5) Install crown gear to differential case using twelve bolts.

Tightening torque:

57 — 67 N·m (5.8 — 6.8 kg-m, 42 — 49 ft-lb)

6) Position drive axle shaft in differential case and hold it with outer snap ring(28). Make sure clearance between the shaft and case is within specifications.

Clearance:

0 — 0.2 mm (0 — 0.008 in)

If it is not within specifications, replace snap ring with a suitable one.

•1600•1800cc FWD

Outer Snap Ring	
Part No.	Thickness mm (in)
805026010	1.05 (0.0413)
031526000	1.20 (0.0472)

•Others

Outer Snap Ring	
Part No.	Thickness mm (in)
805028011	1.05 (0.0413)
805028012	1.20 (0.0472)

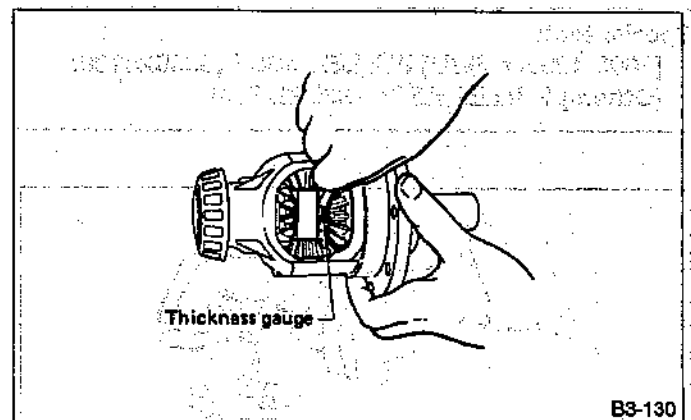
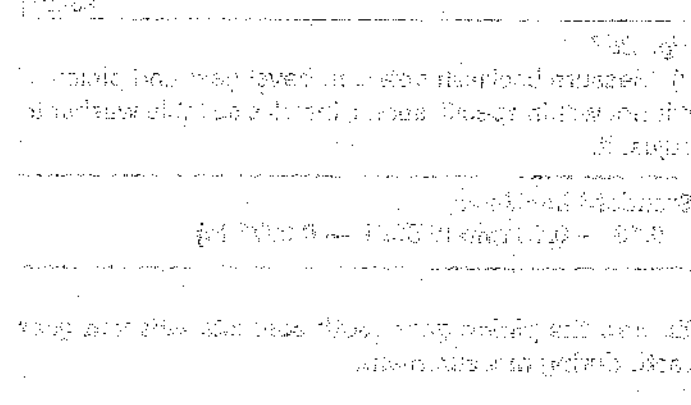
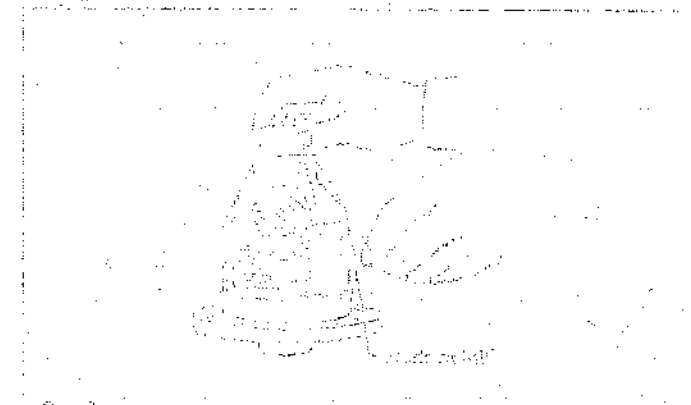
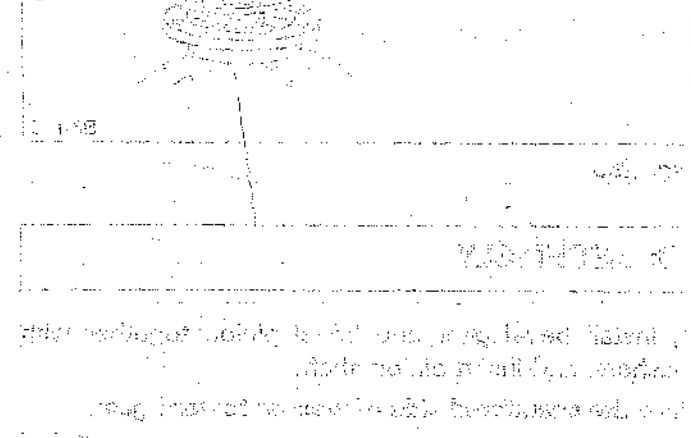


Fig. 260



T TROUBLESHOOTING

Condition and possible cause	Corrective action
<p>1. Gears are difficult to intermesh: The cause for difficulty in shifting gears can be classified into two kinds: one is malfunction of the gear shift system and the other is malfunction of the transmission. However, if the operation is heavy and engagement of the gears is difficult, defective clutch disengagement may also be responsible. Check whether the clutch is correctly functioning, before checking the gear shift system and transmission.</p>	
(a) Worn, damaged or burred chamfer of internal spline of sleeve and reverse driven gear.	Replace.
(b) Worn, damaged or burred chamfer of spline of gears.	Replace.
(c) Worn or scratched bushings.	Replace.
(d) Incorrect contact between synchronizer ring and gear cone or wear.	Correct or replace.
<p>2. Gear slips out.</p>	
(1) Gear slips out when coasting on rough road.	
(2) Gear slips out during acceleration.	
(a) Defective pitching stopper adjustment.	Adjust.
(b) Loose engine mounting bolts.	Tighten or replace.
(c) Worn fork shifter, broken shifter fork rail spring.	Replace.
(d) Worn or damaged ball bearing.	Replace.
(e) Excessive clearance between splines of synchronizer hub and synchronizer sleeve.	Replace.
(f) Worn tooth step of synchronizer hub (responsible for slip-out of 3rd gear).	Replace.
(g) Worn 1st driven gear, needle bearing and race.	Replace.
(h) Worn 2nd driven gear, needle bearing and race.	Replace.
(i) Worn 3rd drive gear and bushing.	Replace.
(j) Worn 4th drive gear and bushing.	Replace.
(k) Worn reverse idler gear and bushing.	Replace.
<p>3. Unusual noise from transmission. If an unusual noise is heard when the car is parked with its engine idling and if the noise ceases when the clutch is disengaged, it may be considered that the noise comes from the transmission.</p>	
(a) Insufficient or improper lubrication.	Lubricate or replace with specified oil.
(b) Worn or damaged gears and bearings.	Replace.
(NOTE) If the trouble is only wear of the tooth surfaces, merely a high roaring noise will occur at high speeds, but if any part is broken, rhythmical knocking sound will be heard even at low speeds.	
<p>4. Broken differential (case, gear, bearing, etc.) Abnormal noise will develop and finally it will become impossible to continue to run due to broken pieces obstructing the gear revolution.</p>	
(a) Insufficient or improper oil.	Disassemble differential and replace broken components and at the same time check other components for any trouble, and replace if necessary.
(b) Use of vehicle under severe conditions such as excessive load and improper use of clutch.	Readjust bearing preload and backlash and face contact of gears.
(c) Improper adjustment of taper roller bearing.	
(d) Improper adjustment of drive pinion and crown gear.	
(e) Excessive backlash due to worn differential side gear, washer or differential pinion.	Add recommended oil to specified level. Do not use vehicle under severe operating conditions.
(f) Loose crown gear clamping bolts.	

Condition and possible cause	Corrective action
<p>5. Differential and hypoid gear noises. Troubles of the differential and hypoid gear always appear as noise problems. Therefore noise is the first indication of the trouble. However noises from the engine, muffler, tire, exhaust gas, bearing, body, etc. are easily mistaken for the differential noise. Pay special attention to the hypoid gear noise because it is easily confused with other gear noises. There are following four kinds of noises.</p> <p>(1) Gear noise when driving: If noise increases as vehicle speed increases it may be due to insufficient gear oil, incorrect gear engagement, damaged gears, etc.</p> <p>(2) Gear noise when coasting: Damaged gears due to maladjusted bearings and incorrect shim adjustment.</p> <p>(3) Bearing noise when driving or when coasting: Cracked, broken or damaged bearings.</p> <p>(4) Noise which mainly occurs when turning: Unusual noise from differential side gear, differential pinion, differential pinion shaft, etc.</p>	
(a) Insufficient oil	Lubricate.
(b) Improper adjustment of crown gear and drive pinion.	Check tooth contact.
(c) Worn teeth of crown gear and drive pinion.	Replace in a set. Readjust bearing preload.
(d) Loose roller bearing.	Readjust crown gear to drive pinion backlash and check tooth contact.
(e) Distorted crown gear or differential case.	Replace.
(f) Worn washer and differential pinion shaft.	Replace.

TRANSMISSION CONTROL SYSTEM

3-3

SUBARU®

1992

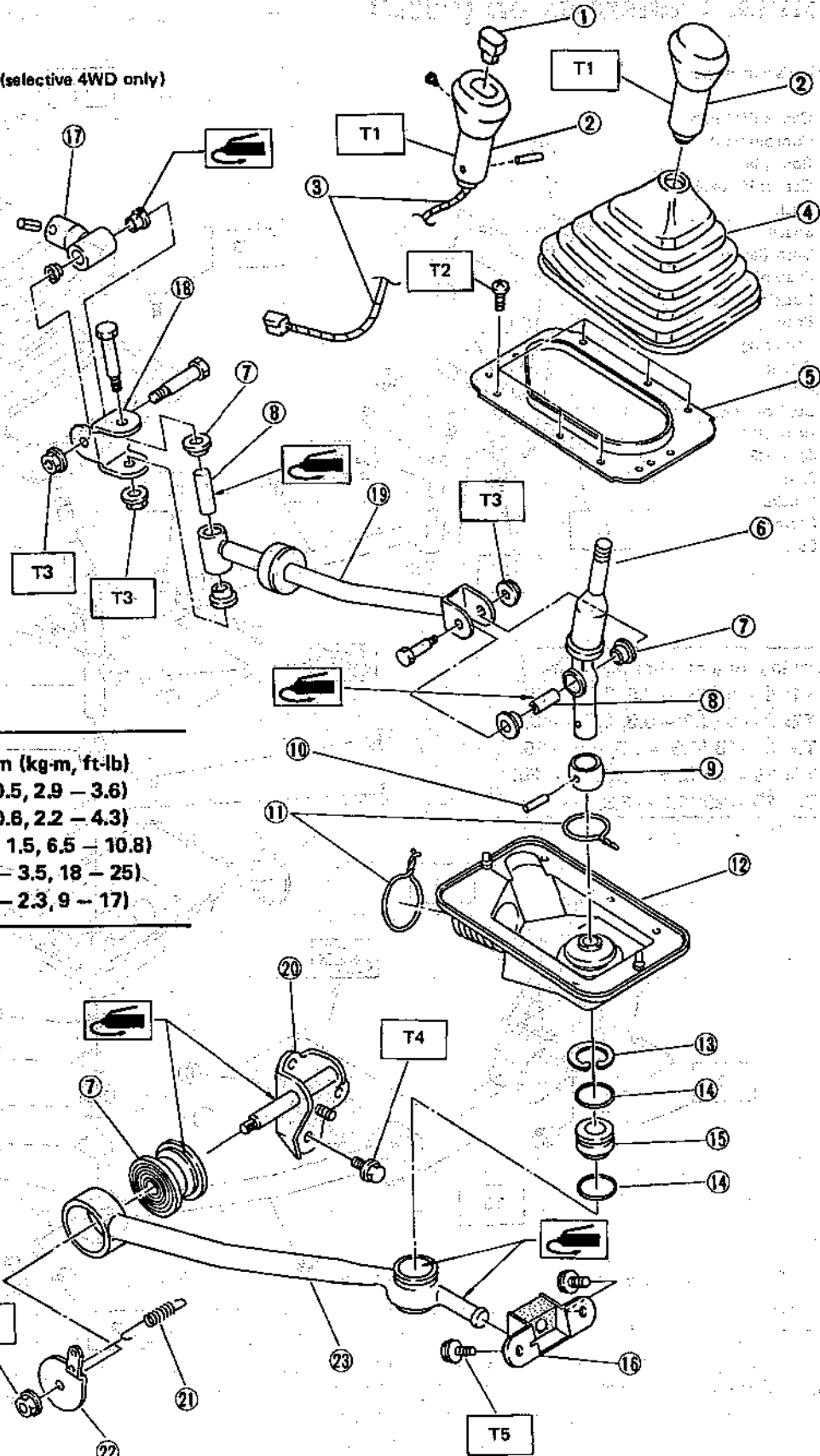
SERVICE MANUAL

	Page
M MECHANISM AND FUNCTION	2
4WD Shift Mechanism (Selective 4WD)	2
C COMPONENT PARTS	3
1. Manual Transmission (FWD)	3
2. Manual Transmission (4WD)	4
3. Drive Select Lever	5
4. Automatic Transmission	6
W SERVICE PROCEDURE	7
1. Manual Transmission (FWD)	7
2. Manual Transmission (4WD)	10
3. Drive Select Lever	14
4. Automatic Transmission	16



2. Manual Transmission (4WD)

- 1 FWD/4WD selector switch (selective 4WD only)
- 2 Gear shift knob
- 3 Selector switch cable
- 4 Console boot
- 5 Boot plate
- 6 Gear shift lever CP
- 7 Bush
- 8 Spacer
- 9 Bush (lever)
- 10 Snap pin
- 11* Locking wire
- 12 Boot
- 13 Snap ring
- 14* O-ring
- 15 Bush
- 16 Cushion rubber
- 17 Boss CP
- 18 Joint CP
- 19 Rod
- 20 Bracket
- 21 Spring
- 22 Dynamic damper
- 23 Stay
- *: Replacement parts



Tightening torque: N·m (kg·m, ft·lb)

T1: 4 - 6 (0.4 - 0.5, 2.9 - 3.6)

T2: 3 - 6 (0.3 - 0.6, 2.2 - 4.3)

T3: 9 - 15 (0.9 - 1.5, 6.5 - 10.8)

T4: 25 - 34 (2.5 - 3.5, 18 - 25)

T5: 13 - 23 (1.3 - 2.3, 9 - 17)

Fig. 3

- 5) Install the rear console box.
- 6) Tighten the screws to install rear and front console box.
- 7) Install the console cover and the boot.
- 8) Install the gearshift knob.
- 9) Mount the cushion rubber on the body.

Tightening torque:

9 — 15 N·m (0.9 — 1.5 kg-m, 6.5 — 10.8 ft-lb)

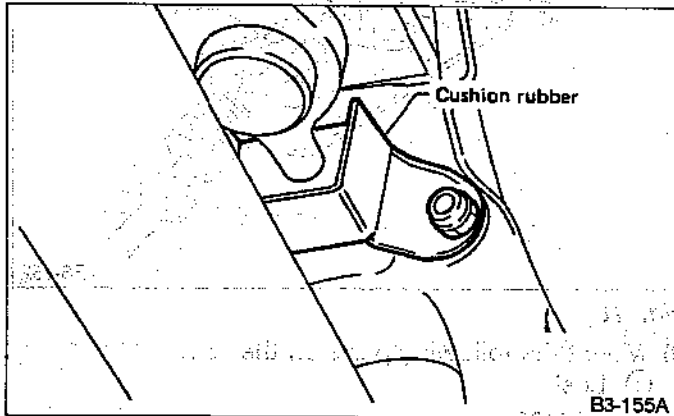


Fig. 20

- 10) Connect the rod to the joint CP.

Tightening torque:

9 — 15 N·m (0.9 — 1.5 kg-m, 6.5 — 10.8 ft-lb)

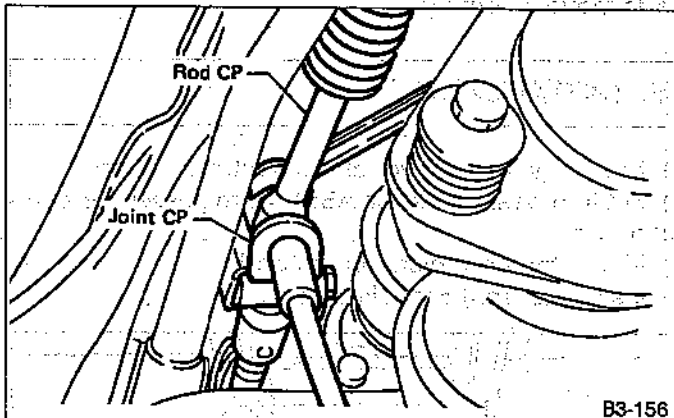


Fig. 21

- 11) Connect the stay CP to the bracket CP.

Tightening torque:

9 — 15 N·m (0.9 — 1.5 kg-m, 6.5 — 10.8 ft-lb)

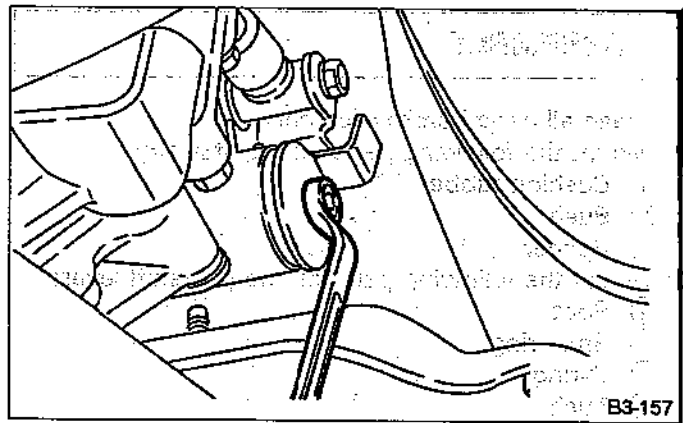


Fig. 22

2. Manual Transmission (4WD)**A: REMOVAL**

- 1) Remove the drive selector lever knob. (Dual-range 4WD model only)

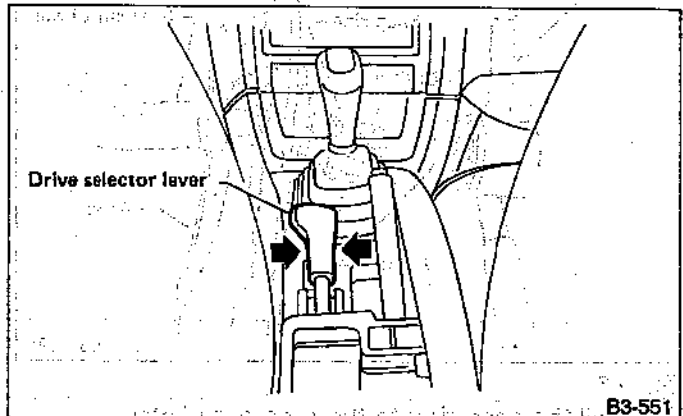


Fig. 23

- 2) Remove the console cover.

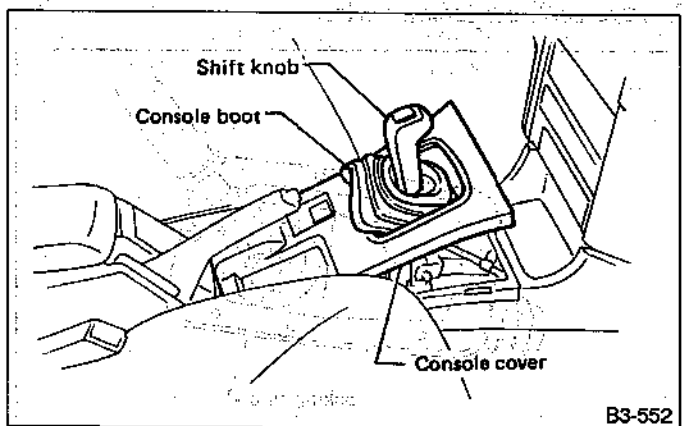


Fig. 24

- 3) Remove drive selector lever ASSY. (Dual-range 4WD model only)

Refer to "Chapter 3-3: Dual range lever [W2E0]".

- 4) Remove the rear and front console boxes.
- 5) Disconnect the 4WD switch connector.

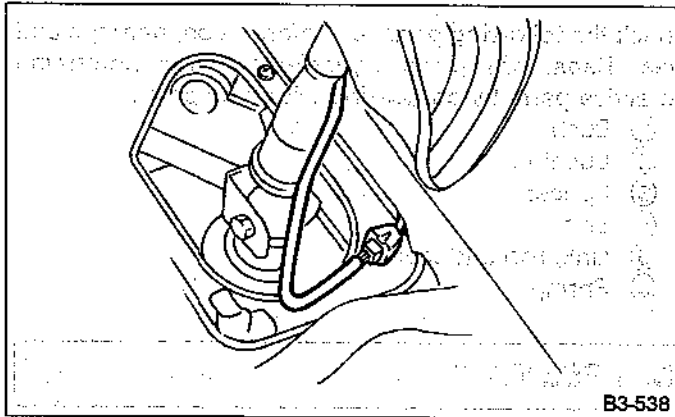


Fig. 25

- 6) Remove the gearshift lever knob, and console boot.
- 7) Remove the boot plate from the body.

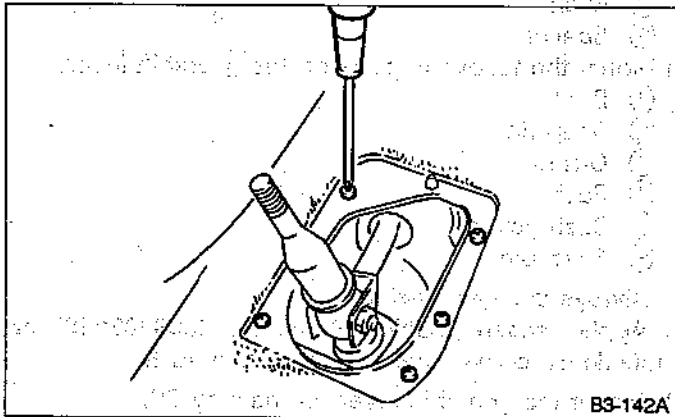


Fig. 26

- 8) Remove the gearshift lever ASSY from the transmission.
 - (1) Remove the spring between the joint CP and the bracket CP.

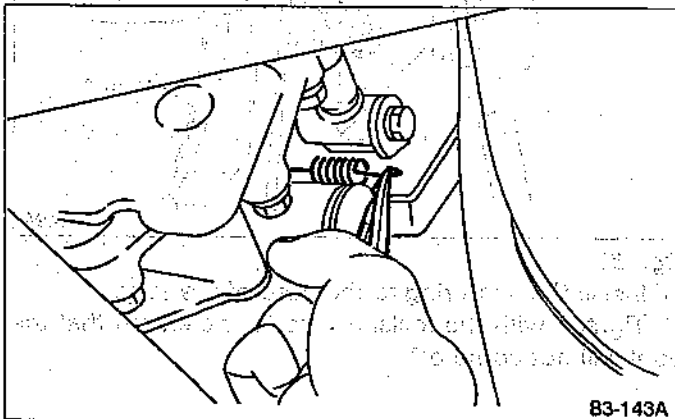


Fig. 27

- (2) Remove the stay from the bracket CP.
- (3) Remove the rod from the joint CP.

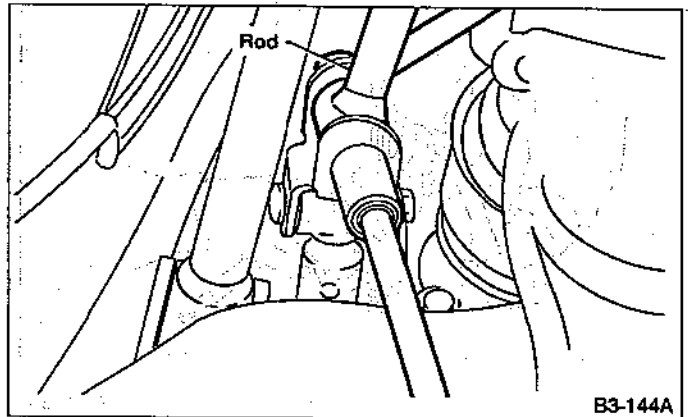


Fig. 28

- 9) Remove the cushion rubber from the body.
- 10) Remove the gearshift lever.

B: DISASSEMBLY

- 1) Remove the cushion rubber from the stay CP.
- 2) Remove the bolt to the take off rod CP from the gearshift lever.
- 3) Disconnect the locking wire.
- 4) Remove the rod CP from the gearshift lever.

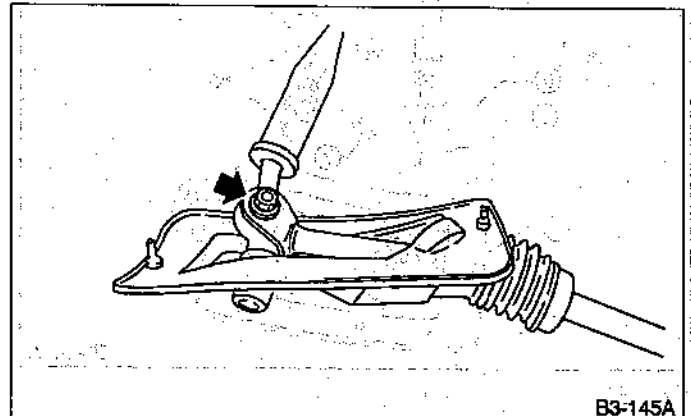
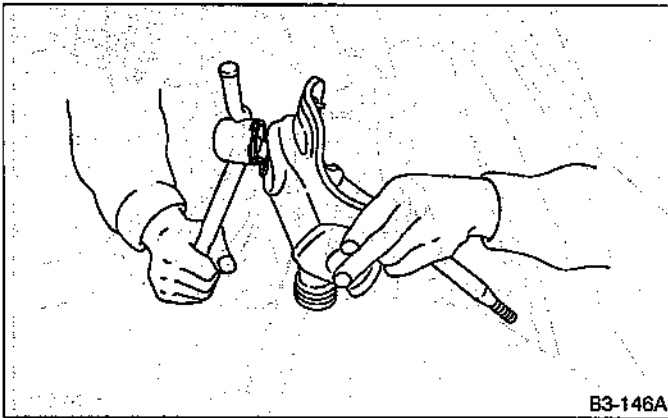


Fig. 29

- 5) Remove the boot.
- 6) Disconnect the snap ring.
- 7) Remove the gearshift lever from the stay CP.
- 8) Disconnect spring pin and bush from gearshift lever CP.
- 9) Remove boot from gearshift CP.

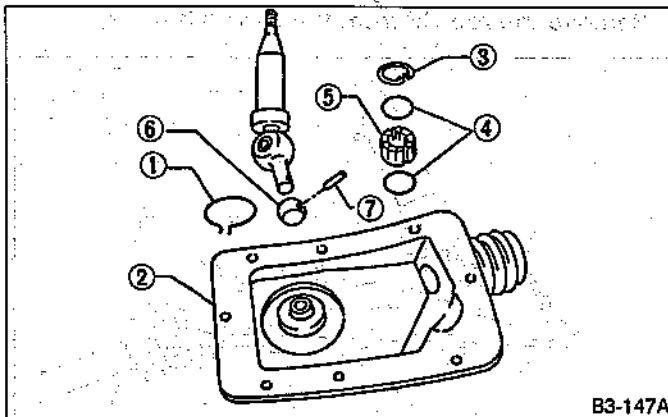


B3-146A

Fig. 30

10) Remove the following parts from the gearshift lever.

- ① Locking wire
- ② Boot
- ③ Snap ring
- ④ O-ring
- ⑤ Bush
- ⑥ Bush (lever)
- ⑦ Spring pin

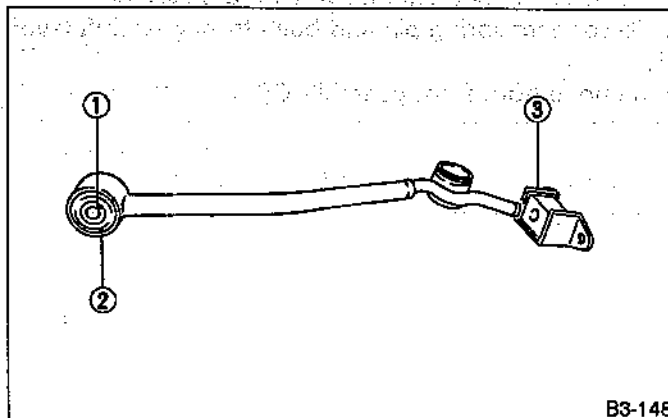


B3-147A

Fig. 31

11) Remove the following parts from the stay CP:

- ① Spacer
- ② Bush
- ③ Cushion rubber



B3-148

Fig. 32

C: INSPECTION

Check the following parts for deformation, damage and wear. Repair or replace any defective parts. Determine defective parts by comparing with new parts.

- ① Bush
- ② Cushion
- ③ Spacer
- ④ Boot
- ⑤ Link, rod and lever
- ⑥ Spring

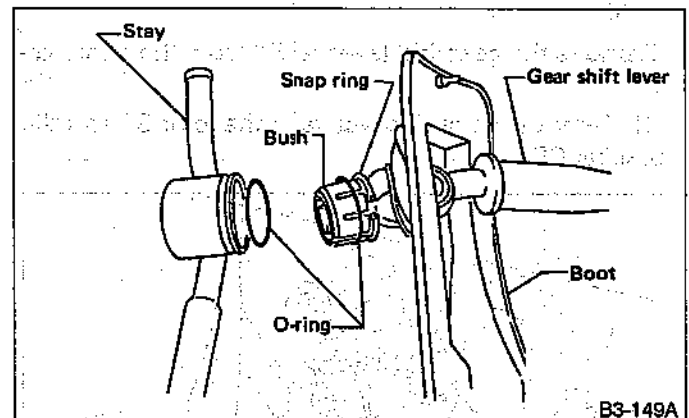
D: ASSEMBLY

- 1) Clean all parts before assembly.
- 2) Mount the following parts on the stay CP:
 - ① Cushion rubber
 - ② Bush
 - ③ Spacer
- 3) Mount the following parts on the gearshift lever:
 - ① Boot
 - ② Snap ring
 - ③ O-ring
 - ④ Bush
 - ⑤ Bush (lever)
 - ⑥ Snap pin

a. Always use new O-rings.

b. Apply grease [SUNLIGHT No. 2 (003602010) or equivalent] to the inner surface of the bush.

- 4) Mount the gearshift lever on the stay CP.



B3-149A

Fig. 33

- 5) Install the snap ring to the case of the stay.
- 6) Tighten with the locking wire to the extent that the boot will not come off.

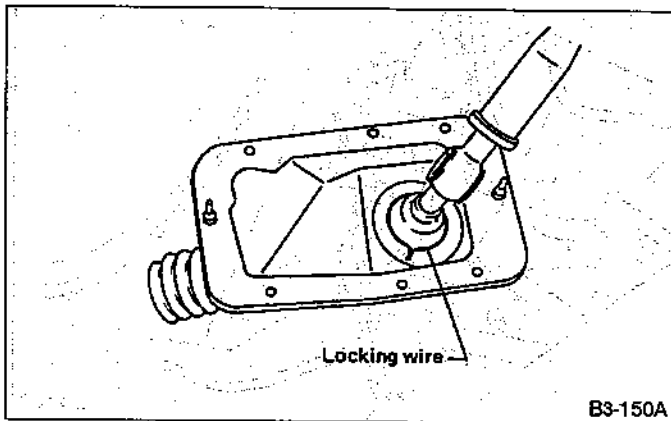


Fig. 34

- 7) Insert the rod into the boot hole.
- 8) Connect the rod to the gearshift lever ASSY.

Tightening torque:

9 — 15 N·m (0.9 — 1.5 kg-m, 6.5 — 10.8 ft-lb)

Locking torque:

2.7 N·m (0.28 kg-m, 2.0 ft-lb)

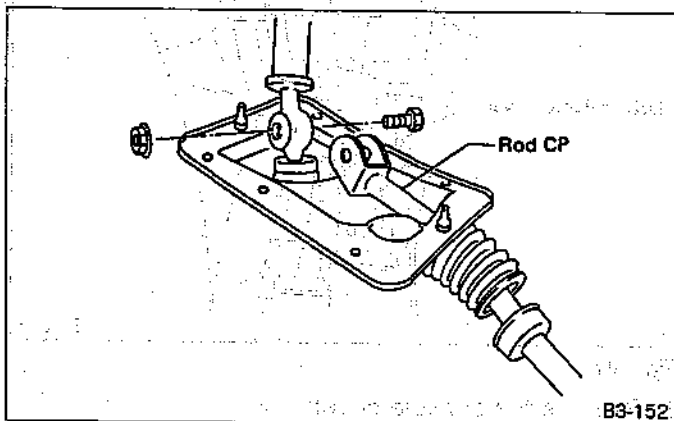


Fig. 35

- 9) Mount the following parts on the rod:

- ① Bush
- ② Spacer

a. Apply grease [SUNLIGHT No. 2 (003602010) or equivalent] to the inner and side surfaces of the bush when installing the spacers.

b. The rod should be installed in the direction shown in the figure below.

- 10) Check that there is no excessive play and that the parts move smoothly.

E: INSTALLATION

- 1) Set the gearshift lever at the neutral position.
- 2) Put into gearshift lever ASSY from passenger compartment.
- 3) Mount the boot plate on the body.
- 4) Install the console boot and gearshift knob on the gearshift lever.
- 5) Connect the 4WD switch connector. (Selective 4WD model only).

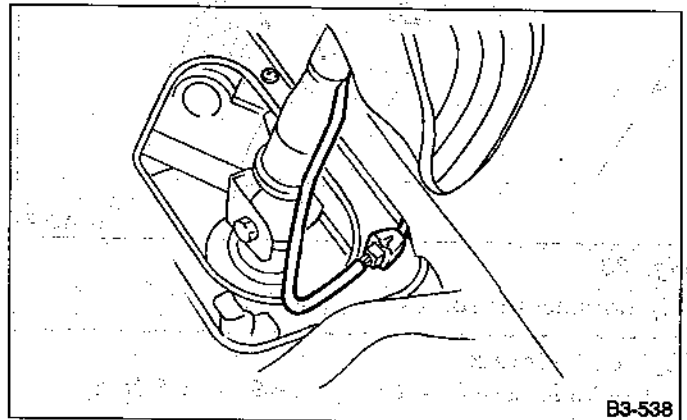


Fig. 36

- 6) Install the front and rear console boxes.
- 7) Install drive selector lever ASSY. (Dual-range 4WD model only)

Refer to "Chapter 3-3 [W3B0]".

- 8) Install the console cover.
- 9) Install the drive selector lever knob. (Dual-range 4WD model only)

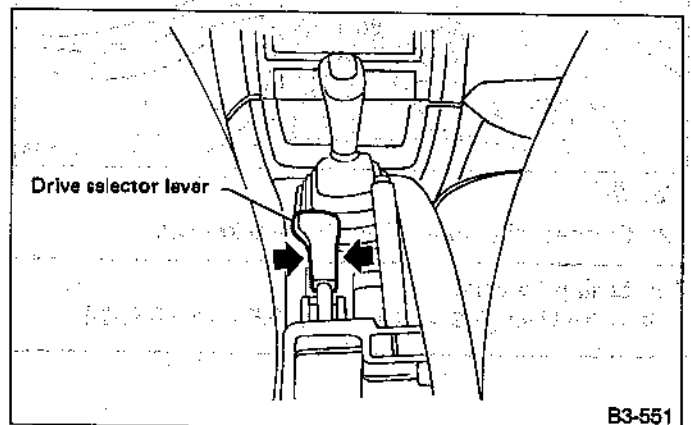


Fig. 37

10) Mount the cushion rubber on the body.

Tightening torque:

9 — 15 N·m (0.9 — 1.5 kg-m, 6.5 — 10.8 ft-lb)

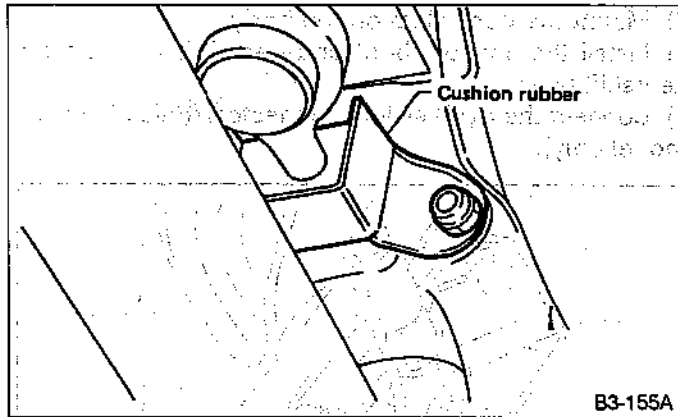


Fig. 38

11) Connect the rod to the joint CP.

Tightening torque:

9 — 15 N·m (0.9 — 1.5 kg-m, 6.5 — 10.8 ft-lb)

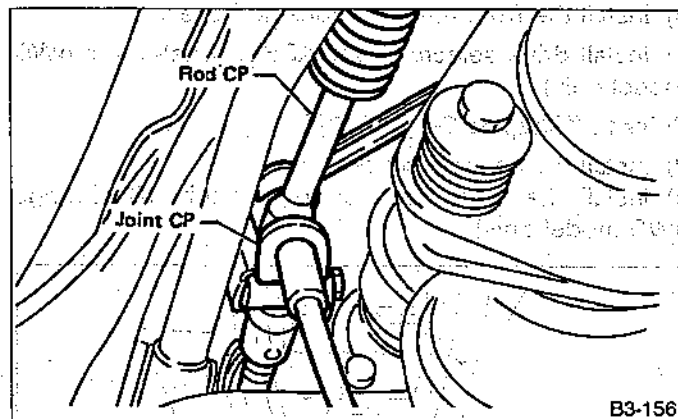


Fig. 39

12) Connect the stay CP to the bracket CP.

Tightening torque:

9 — 15 N·m (0.9 — 1.5 kg-m, 6.5 — 10.8 ft-lb)

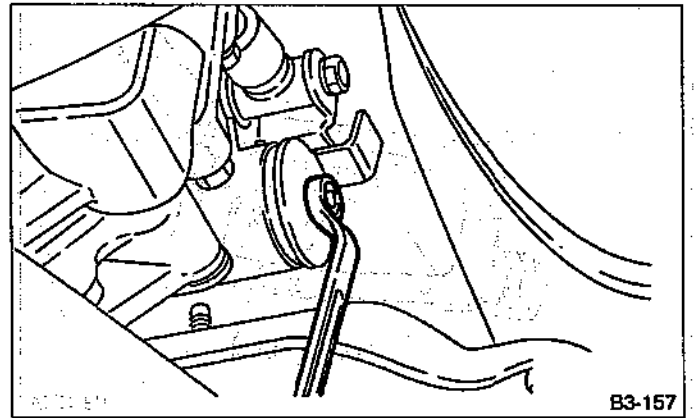


Fig. 40

3. Drive Select Lever

A: REMOVAL

1) Remove the drive select lever knob.

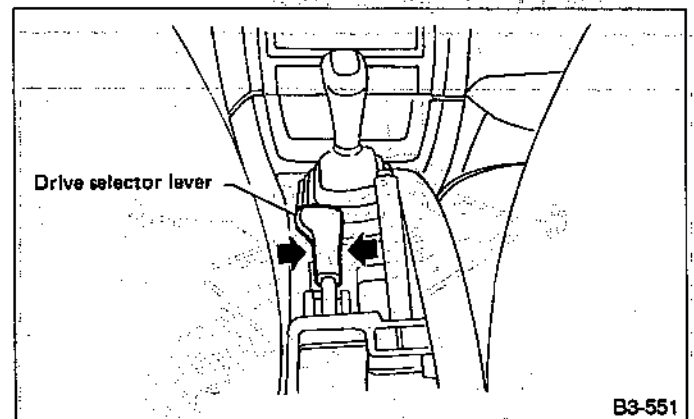


Fig. 41

2) Remove the console cover.

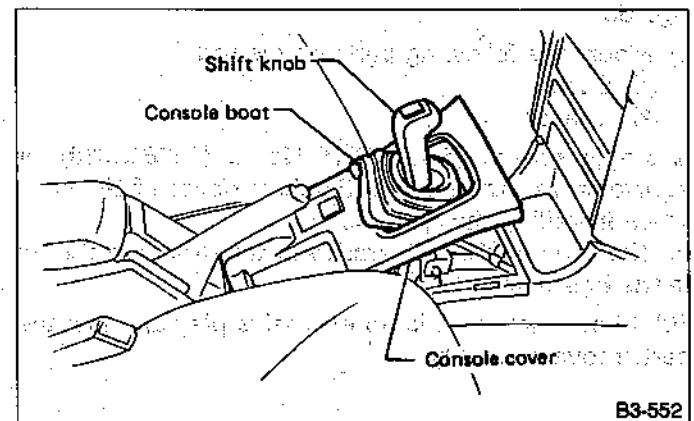


Fig. 42

3) Remove the bolt installing drive select lever ASSY on body.

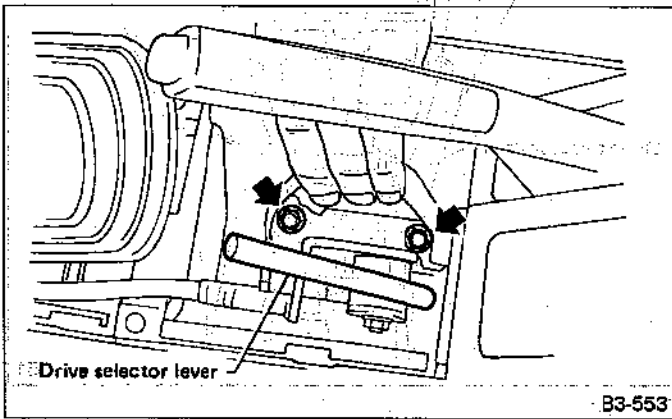


Fig. 43

4) Disconnect cable CP from drive select lever ASSY.
 (1) Remove snap pin connecting the cable to lever ASSY.

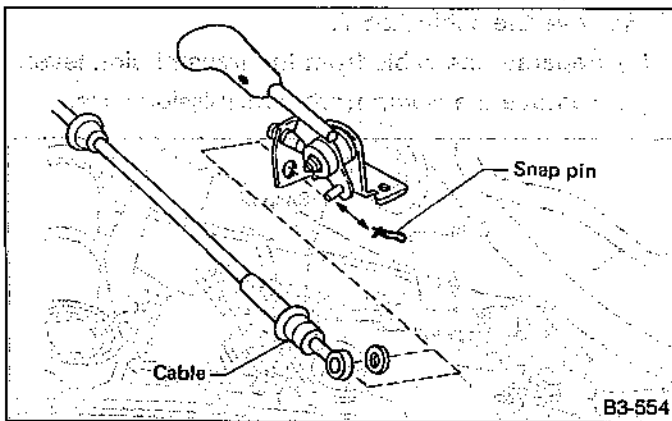


Fig. 44

(2) Remove snap pin connecting the cable to transmission case.

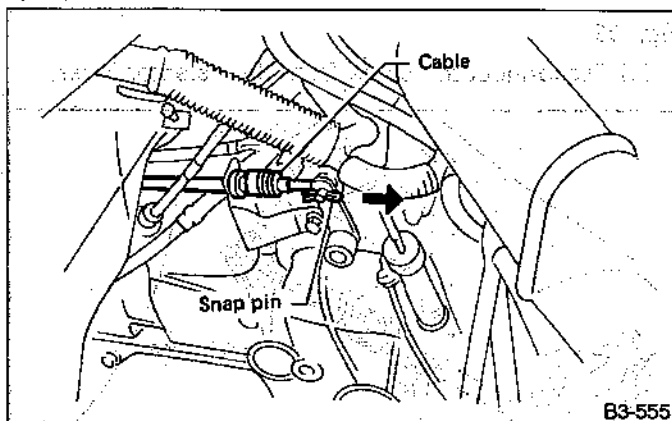


Fig. 45

(3) Remove cable CP from the under side of vehicle.

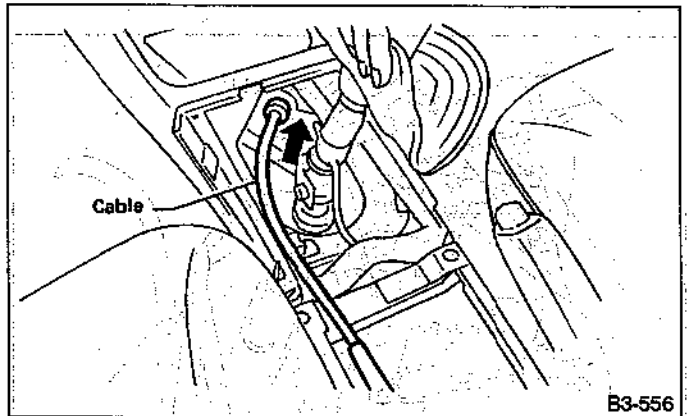


Fig. 46

B: INSTALLATION

1) Insert cable CP into the boot hole from the under side of vehicle.

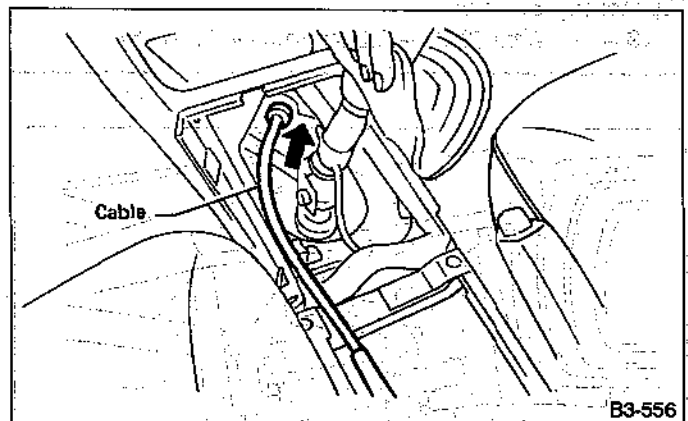


Fig. 47

2) Connect cable CP on drive select lever ASSY, and install snap pin.

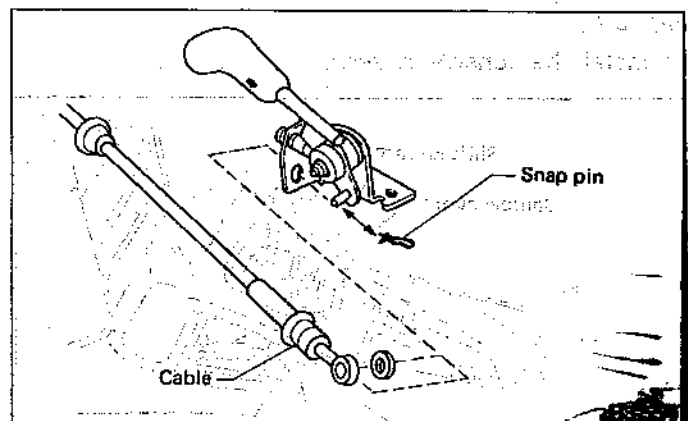


Fig. 48

3) Connect cable CP on transmission case, and install snap pin.

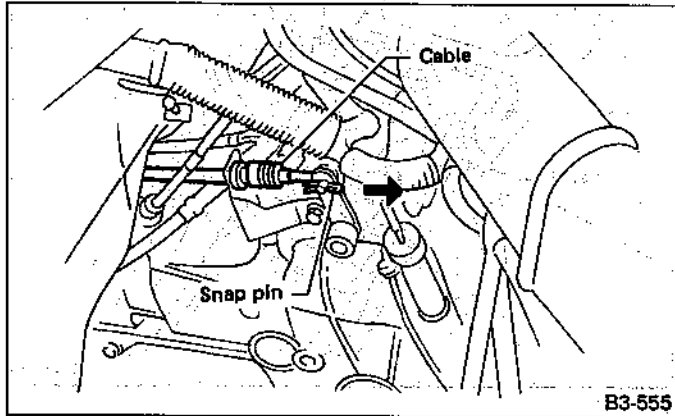


Fig. 49

Apply grease [SUNLIGHT 2 (P/N 003602010)] to parts which connect the cable.

4) Install drive select lever ASSY on body.

Tightening torque:

13 — 23 N·m (1.3 — 2.3 kg-m, 9 — 17 ft-lb)

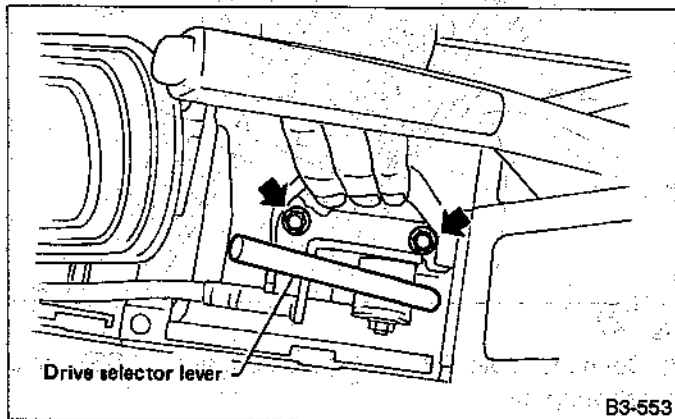


Fig. 50

5) Install the console cover.

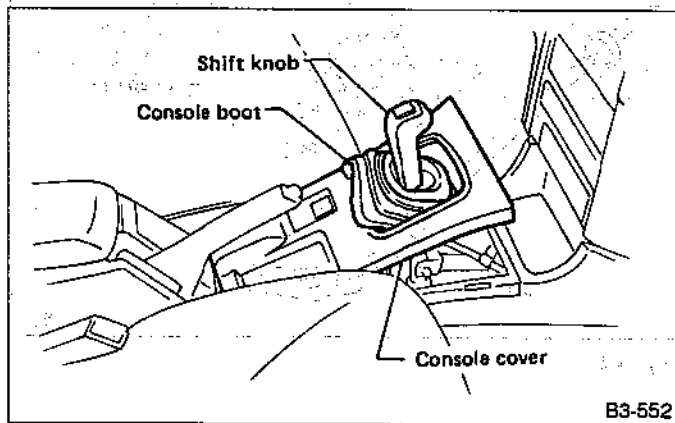


Fig. 51

6) Install the drive select lever knob.

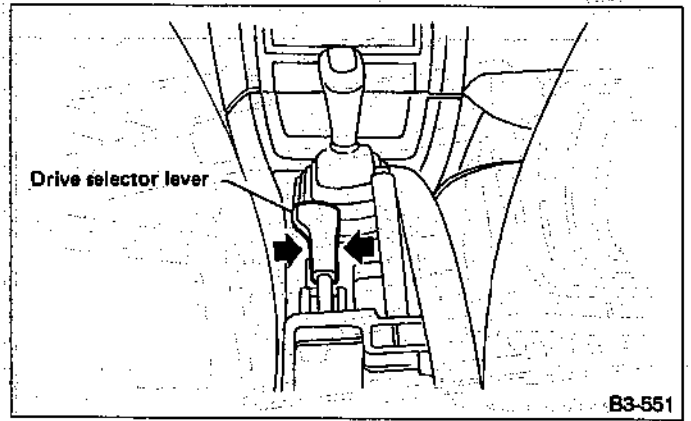


Fig. 52

4. Automatic Transmission

A: REMOVAL

1) Remove the cable ASSY.

- (1) Separate the cable from the transmission lever.
- (2) Remove the clamp from transmission case.

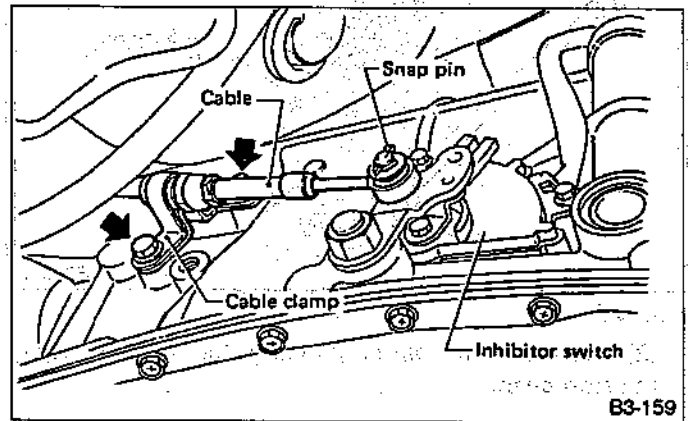


Fig. 53

- (3) Disconnect the cable from the selector lever.

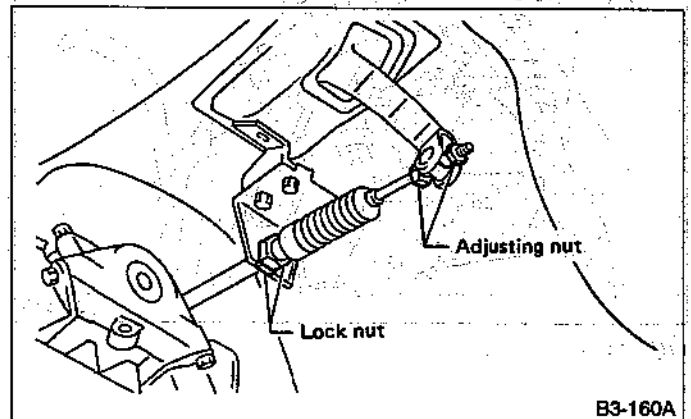


Fig. 54

4WD SYSTEM

3-4

SUBARU®

1992

SERVICE MANUAL

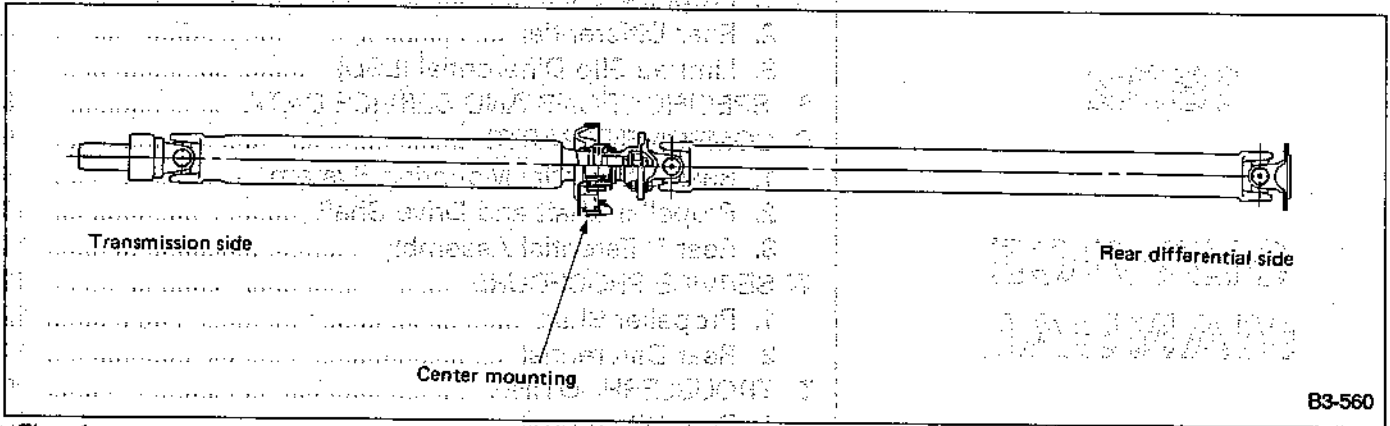
	Page
M MECHANISM AND FUNCTION	2
1. Propeller Shaft	2
2. Rear Differential	3
3. Limited Slip Differential (LSD)	4
S SPECIFICATIONS AND SERVICE DATA	6
C COMPONENT PARTS	9
1. Rear Differential Mounting System	9
2. Propeller Shaft and Drive Shaft	10
3. Rear Differential Assembly	11
W SERVICE PROCEDURE	12
1. Propeller Shaft	12
2. Rear Differential	14
T TROUBLESHOOTING	30
1. Rear Differential	30
2. Propeller Shaft	31



M MECHANISM AND FUNCTION

1. Propeller Shaft

The propeller shaft model utilizes a 2-piece design that is provided with three joints.



B3-560

Fig. 1

2. Rear Differential

A hypoid drive gear with a nominal diameter of 160 mm (6.30 in) is used and the drive pinion shaft is supported on three bearings, the bearing preload being adjusted

by a selective spacer and washer. The drive pinion height is adjusted by selecting washers located at the drive pinion neck using Dummy Shaft and Gauge.

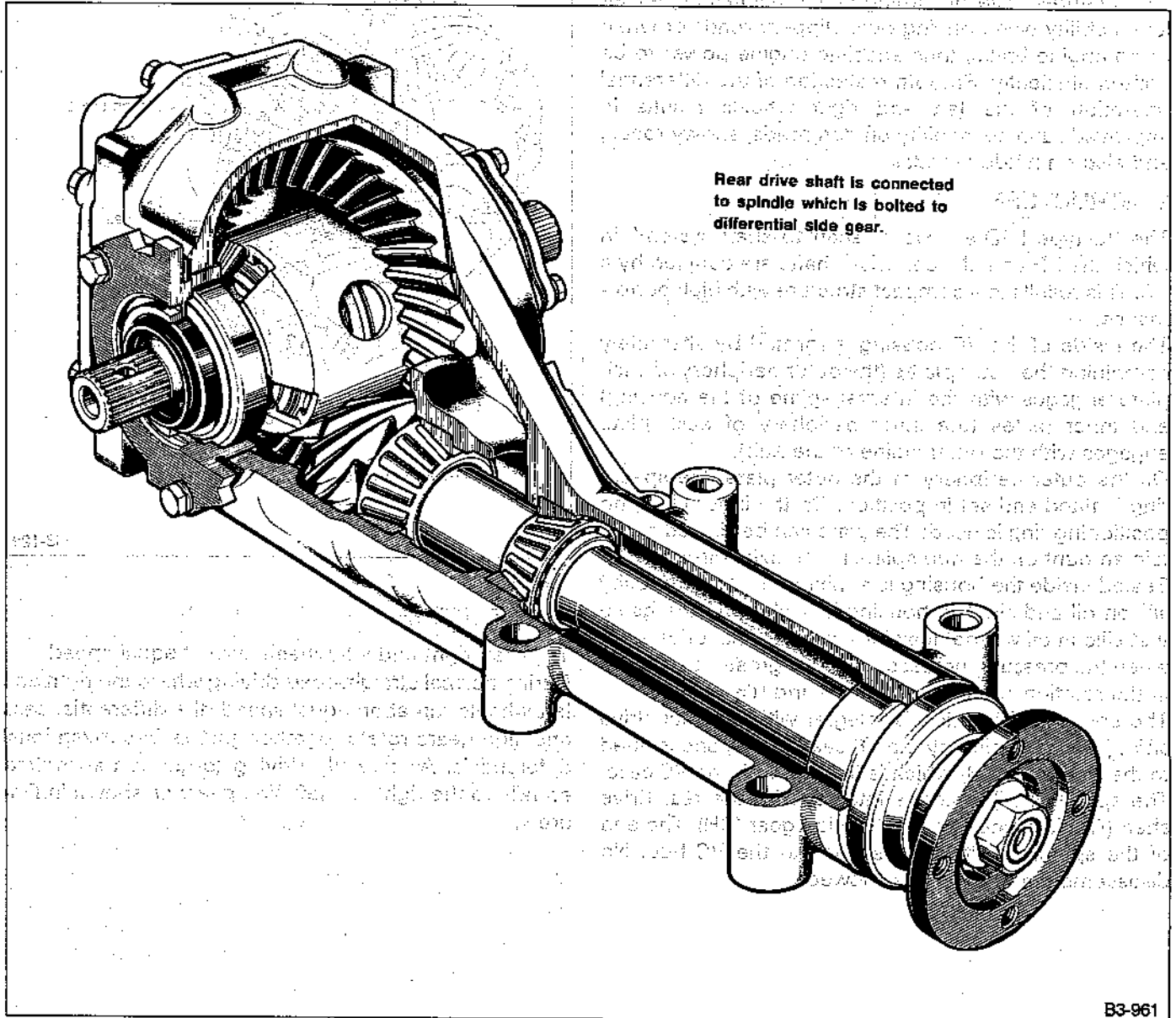


Fig. 2

3. Limited Slip Differential (LSD)

A viscous coupling (VC) type LSD has been adopted so as to ensure safe and smooth transfer of increased power under various driving conditions. This VC type LSD features ease of turning while maintaining excellent stability when driving over slippery roads or when using engine brake, thus enabling engine power to be utilized efficiently. Smooth restriction of the differential operation of the left and right wheels results in improved running stability on bad roads, snowy roads, and also on muddy roads.

1. STRUCTURE

The VC type LSD adopts a "shaft to shaft system" in which the RH and LH rear drive shafts are coupled by a VC. This results in a compact structure with high performance.

The inside of the VC housing is formed by alternately combining the outer plates (the outer periphery of each plate engages with the internal spline of the housing) and inner plates (the inner periphery of each plate engages with the outer spline of the hub).

On the outer periphery of the outer plate, the spacer ring is fitted and set in position. On the inner plate, no positioning ring is used: The plate can be moved a certain amount on the hub spline in the axial direction.

Sealed inside the housing is a mixture of high viscosity silicon oil and air. The housing is sealed by X-rings so that silicon oil will not leak into the rear final drive even when the pressure increases due to a greater difference in the rotation speed between LH and RH wheels.

The spindle (LH) which is integral with the rear drive shaft (LH) is coupled by the VC case spline, and is fitted to the side gear (LH) which is integral with the VC case. The spindle (RH) which is integral with the rear drive shaft (RH) is spline fitted to the side gear (RH). The end of the spindle is fitted by splines to the VC hub. No disassembling of the VC is allowed.

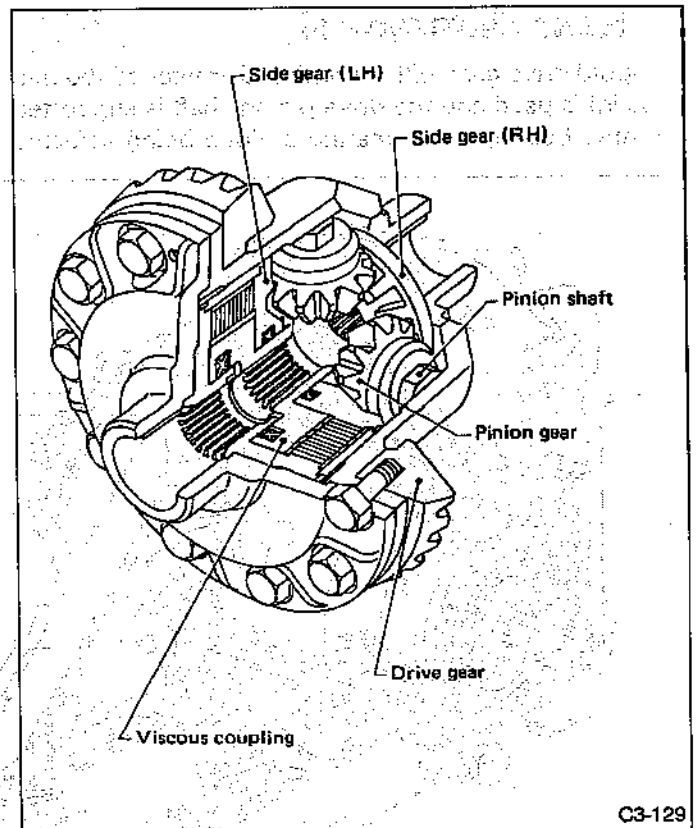


Fig. 3

2. OPERATION

1) When right and left wheels turn at equal speed
During normal straight-road driving where the right and left wheels run at an equal speed, the differential case and side gears rotate together, just as in conventional differentials. As a result, driving torque is transmitted equally to the right and left side gears as shown in Figure 4.

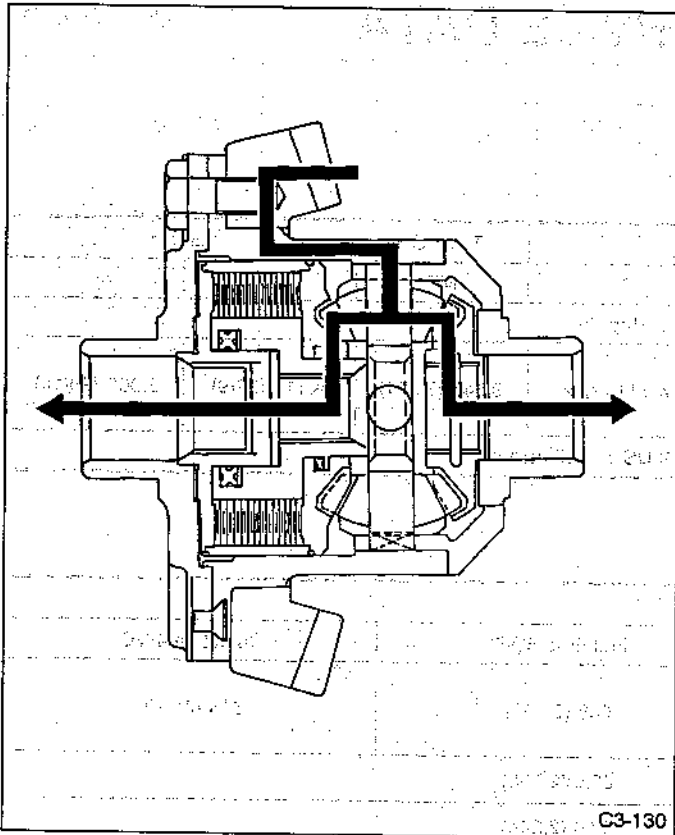


Fig. 4

2) When right and left wheels turn at different speeds. When a speed difference occurs between the right and left wheels, the VC housing and VC hub turn relatively at the same speed difference as that of the rear drive shaft. Because of the shearing force caused in the silicon oil, a differential torque is generated, which controls differential operation (idle rotation). For example, if the left wheel turns idle due to a difference in the road resistance, a speed difference occurs between the right and left wheel. Since the VC is installed between the right and left wheels, a differential torque is generated in the VC corresponding to this speed difference, and this differential torque is transferred from the left wheel to the right wheel. Accordingly, a greater driving force

is transferred to the right wheel which is rotating at a lower speed as shown in Figure 5.

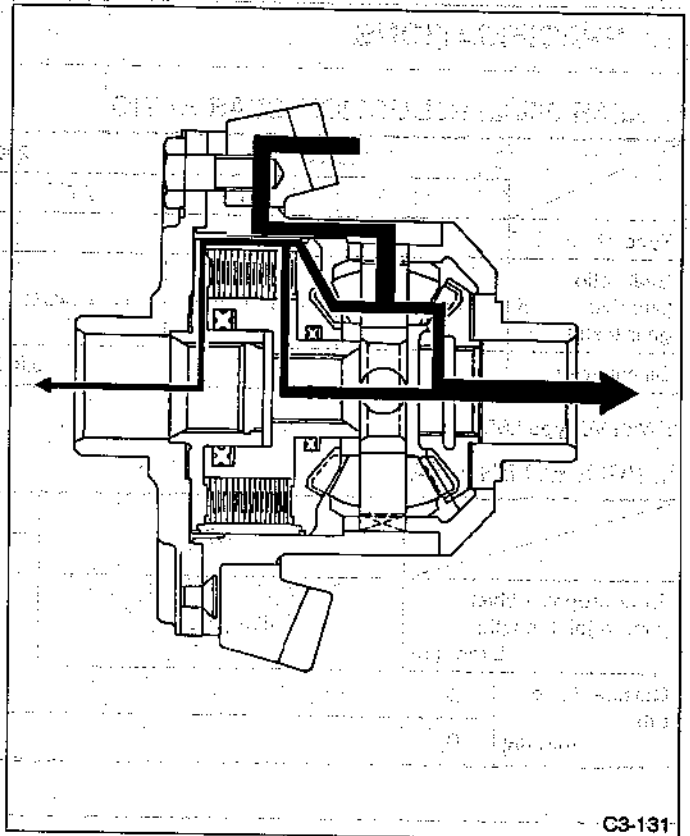


Fig. 5

3. SERVICE PROCEDURES FOR LSD

The component parts of LSD ASSY are not available as piece parts.

Therefore, it is recommended to not disassemble LSD ASSY.

S SPECIFICATIONS AND SERVICE DATA

A: SPECIFICATIONS

1. REAR FINAL REDUCTION GEAR RATIO

	1800cc		2000cc		TURBO*	2200cc	
	AT	MT	AT	MT	MT	AT	MT
Type of gear	Hypoid						
Gear ratio (Number of gear teeth)	4.444 (40/9)	4.111 (37/9)	4.444 (40/9)	4.111 (37/9)	3.545 (39/11)	4.111 (37/9)	3.900 (39/10)
Oil capacity	0.8 ℓ (0.8 US qt, 0.7 Imp qt)						

*: With VC type LSD

2. PROPELLER SHAFT

	AT	MT	
		Full-time 4WD	Selective 4WD
Front propeller shaft joint-to-joint length: L mm (in)	489 (19.25)	548 (21.57)	613 (24.13)
Outside dia. of tube mm (in)	D ₁	63.5 (2.500)	
	D ₂	57.0 (2.244)	

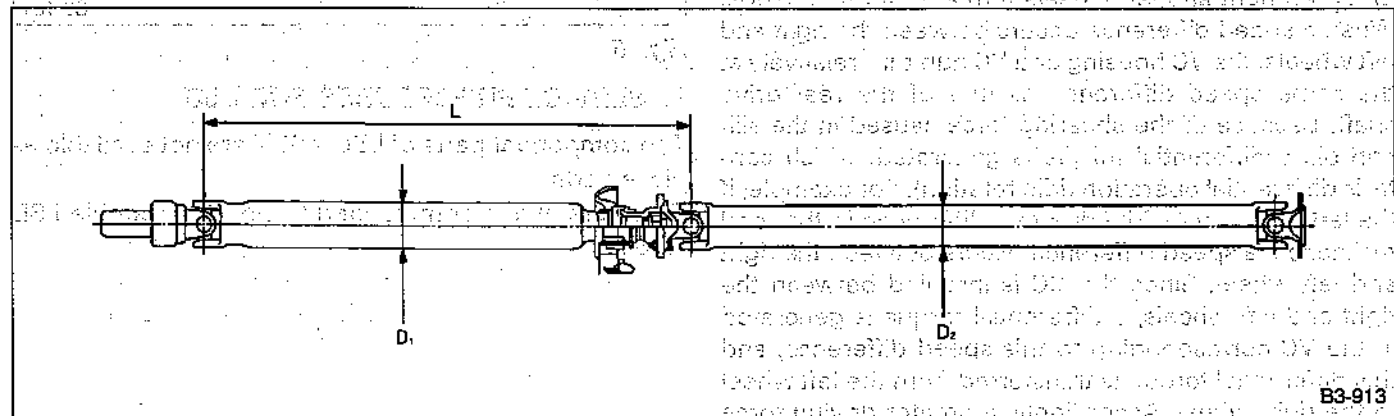


Fig. 6

B3-913

3. DRIVE SHAFT

Type of drive shaft ASSY	SHAFT			
	No. of identification paddings on shaft	Distance between inner and outer boots (L) mm (in)	Diameter (D) mm (in)	
			D ₁	D ₂
82AC-RH	1 (One)	304 (11.97)	21.2 (0.835)	24 (0.94)
82AC-LH		294 (11.57)		21.2 (0.835)
87AC-RH	2 (Two)	277 (10.91)	22.22 (7/8)	25 (0.98)
87AC-LH		267 (10.51)		22.22 (7/8)

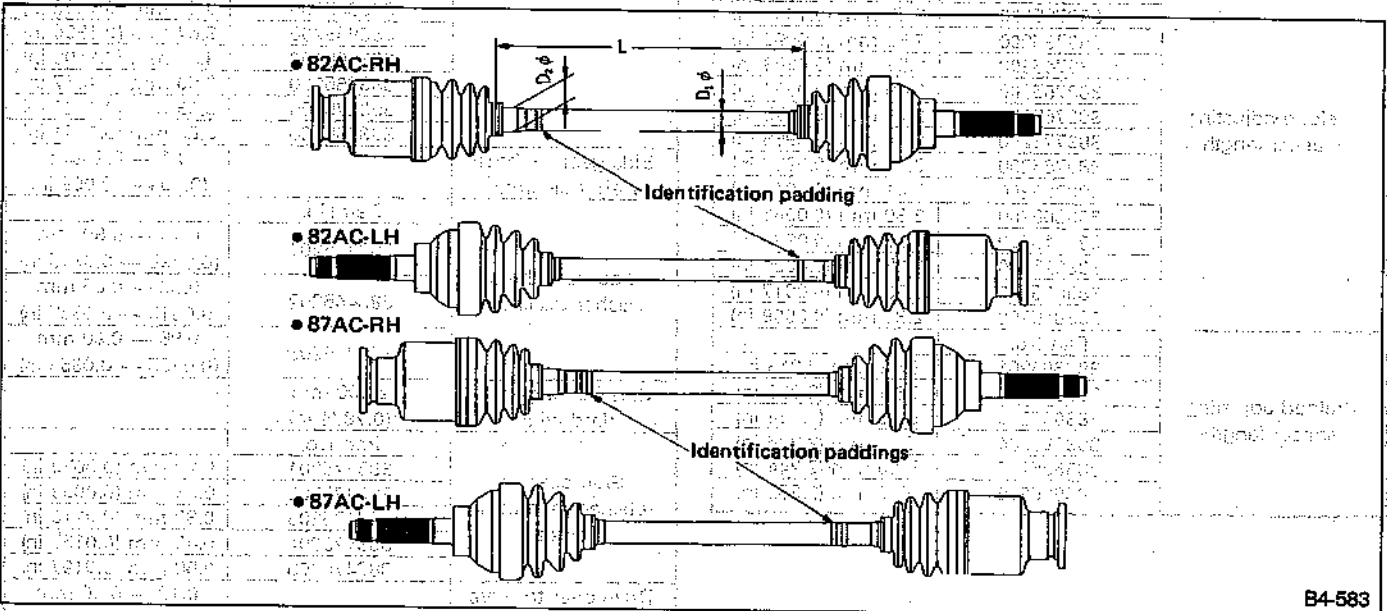


Fig. 7

4. APPLICATION TABLE

	Power unit			
	1800cc	2000cc	2000cc Turbo	2200cc
Drive shaft	82AC-RH 82AC-LH		87AC-RH 87AC-LH	

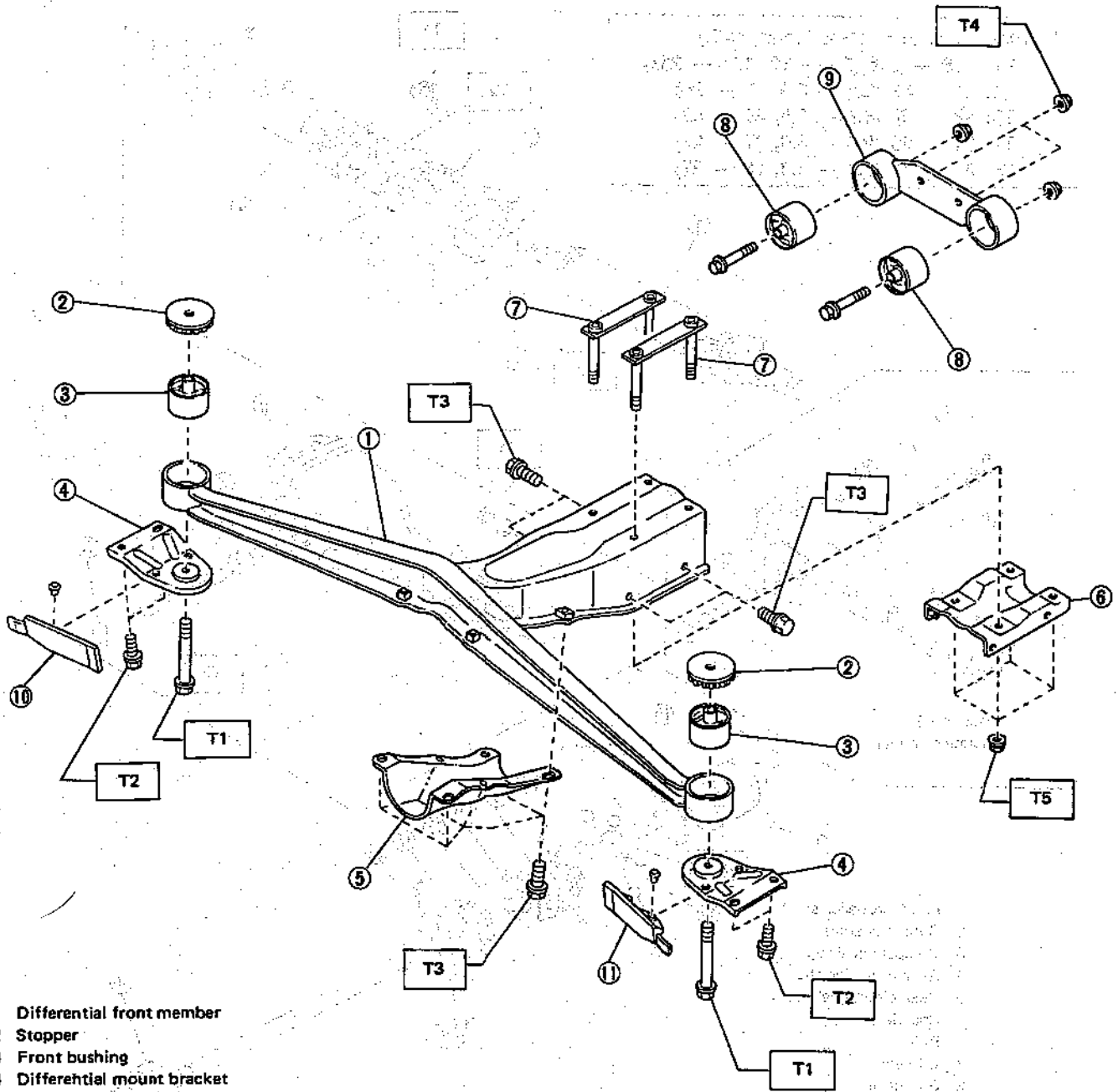
B: SERVICE DATA**Rear differential**

Front & rear bearing preload at companion flange bolt hole	New bearing	19.6 — 28.4 N (2.0 — 2.9 kg, 4.4 — 6.4 lb)
	Used bearing	8.34 — 16.67 N (0.85 — 1.7 kg, 1.87 — 3.75 lb)
Preload adjusting washer length	Part No.	
	383705200	2.59 mm (0.1020 in)
	383715200	2.57 mm (0.1012 in)
	383725200	2.55 mm (0.1004 in)
	383735200	2.53 mm (0.0996 in)
	383745200	2.51 mm (0.0988 in)
	383755200	2.49 mm (0.0980 in)
	383765200	2.47 mm (0.0972 in)
	383775200	2.45 mm (0.0965 in)
	383785200	2.43 mm (0.0957 in)
	383795200	2.41 mm (0.0949 in)
	383805200	2.39 mm (0.0941 in)
	383815200	2.37 mm (0.0933 in)
	383825200	2.35 mm (0.0925 in)
	383835200	2.33 mm (0.0917 in)
Preload adjusting spacer length	Part No.	
	383695201	56.2 mm (2.213 in)
	383695202	56.4 mm (2.220 in)
	383695203	56.6 mm (2.228 in)
	383695204	56.8 mm (2.236 in)
	383695205	57.0 mm (2.244 in)
383695206	57.2 mm (2.252 in)	

Pinion height adjusting washer thickness	Part No.	
	383495200	3.09 mm (0.1217 in)
	383505200	3.12 mm (0.1228 in)
	383515200	3.15 mm (0.1240 in)
	383525200	3.18 mm (0.1252 in)
	383535200	3.21 mm (0.1264 in)
	383545200	3.24 mm (0.1276 in)
	383555200	3.27 mm (0.1287 in)
	383565200	3.30 mm (0.1299 in)
	383575200	3.33 mm (0.1311 in)
	383585200	3.36 mm (0.1323 in)
	383595200	3.39 mm (0.1335 in)
	383605200	3.42 mm (0.1346 in)
	383615200	3.45 mm (0.1358 in)
	383625200	3.48 mm (0.1370 in)
	383635200	3.51 mm (0.1382 in)
	383645200	3.54 mm (0.1394 in)
	38365200	3.57 mm (0.1406 in)
383665200	3.60 mm (0.1417 in)	
383675200	3.63 mm (0.1429 in)	
383685200	3.66 mm (0.1441 in)	
Side gear to thrust washer clearance		0.1 — 0.2 mm (0.004 — 0.008 in)
Side gear thrust washer thickness	Part No.	
	383445201	0.75 — 0.80 mm (0.0295 — 0.0315 in)
	383445202	0.80 — 0.85 mm (0.0315 — 0.0335 in)
	383445203	0.85 — 0.90 mm (0.0335 — 0.0354 in)
Side bearing standard width		20.00 mm (0.7874 in)
Side bearing retainer shim thickness	Part No.	
	383475201	0.20 mm (0.0079 in)
	383475202	0.25 mm (0.0098 in)
	383475203	0.30 mm (0.0118 in)
	383475204	0.40 mm (0.0157 in)
383475205	0.50 mm (0.0197 in)	
Drive gear to drive pinion backlash		0.10 — 0.20 mm (0.0039 — 0.0079 in)
Drive gear runout on its back surface	Limit	0.05 mm (0.0020 in)
Oil capacity		0.8 ℓ (0.8 US qt, 0.7 Imp qt)

C COMPONENT PARTS

1. Rear Differential Mounting System



- 1 Differential front member
- 2 Stopper
- 3 Front bushing
- 4 Differential mount bracket
- 5 Differential mount front cover
- 6 Differential mount lower cover
- 7 Plate
- 8 Rear bushing
- 9 Differential rear member
- 10 Protector (RH)
- 11 Protector (LH)

Tightening torque: N-m (kg-m, ft-lb)

T1: 88 - 108 (9 - 11, 65 - 80)

T2: 25 - 40 (2.5 - 4.1, 18 - 30)

T3: 59 - 78 (6 - 8, 43 - 58)

T4: 69 - 88 (7 - 9, 51 - 65)

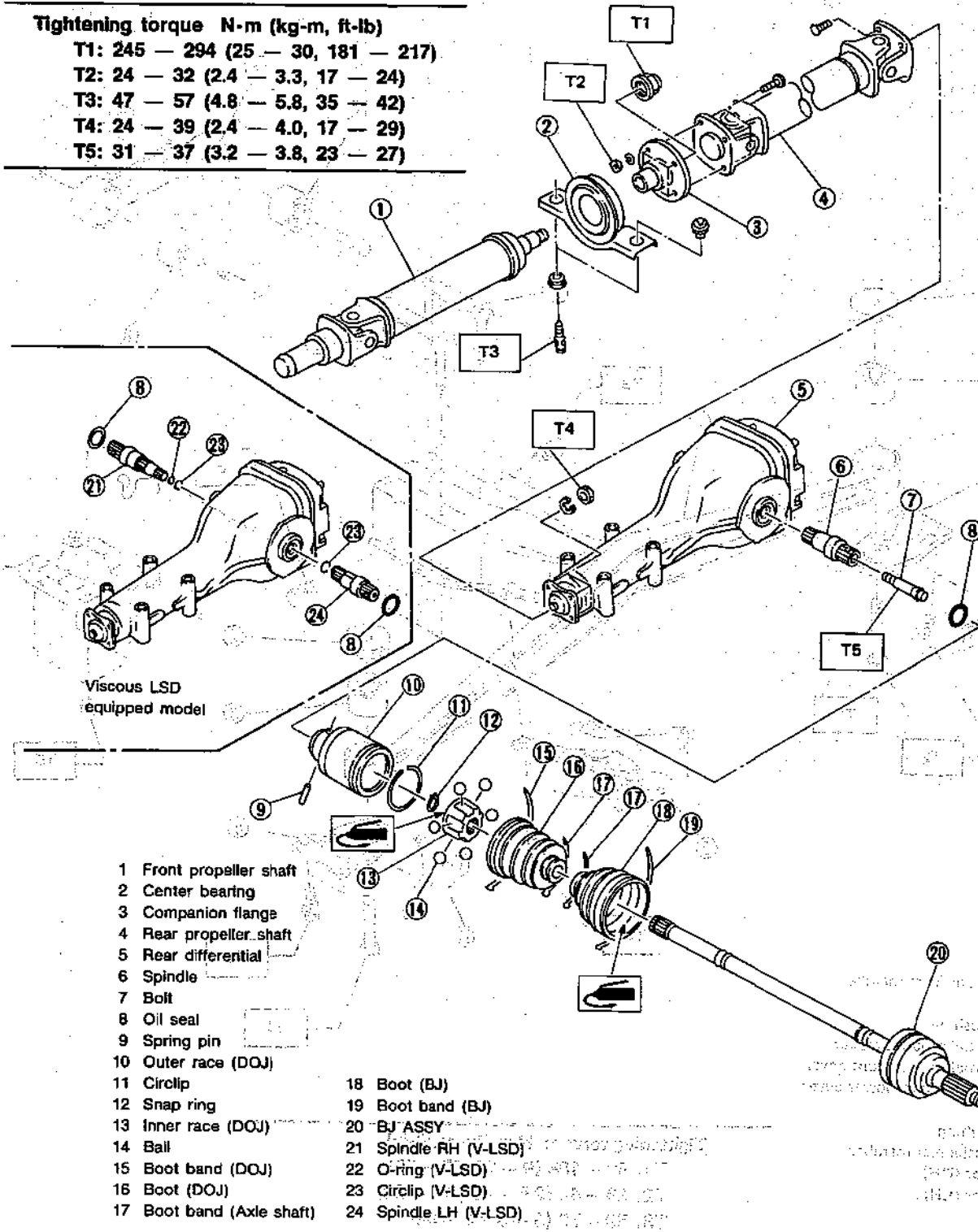
T5: 56 - 72 (5.7 - 7.3, 41 - 53)

Fig. 8

83-185

2. Propeller Shaft and Drive Shaft

Tightening torque N-m (kg-m, ft-lb)	
T1:	245 — 294 (25 — 30, 181 — 217)
T2:	24 — 32 (2.4 — 3.3, 17 — 24)
T3:	47 — 57 (4.8 — 5.8, 35 — 42)
T4:	24 — 39 (2.4 — 4.0, 17 — 29)
T5:	31 — 37 (3.2 — 3.8, 23 — 27)



- 1 Front propeller shaft
- 2 Center bearing
- 3 Companion flange
- 4 Rear propeller shaft
- 5 Rear differential
- 6 Spindle
- 7 Bolt
- 8 Oil seal
- 9 Spring pin
- 10 Outer race (DOJ)
- 11 Circlip
- 12 Snap ring
- 13 Inner race (DOJ)
- 14 Ball
- 15 Boot band (DOJ)
- 16 Boot (DOJ)
- 17 Boot band (Axle shaft)
- 18 Boot (BJ)
- 19 Boot band (BJ)
- 20 BJ ASSY
- 21 Spindle RH (V-LSD)
- 22 O-ring (V-LSD)
- 23 Circlip (V-LSD)
- 24 Spindle LH (V-LSD)

B3-914

Fig. 9

3. Rear Differential Assembly

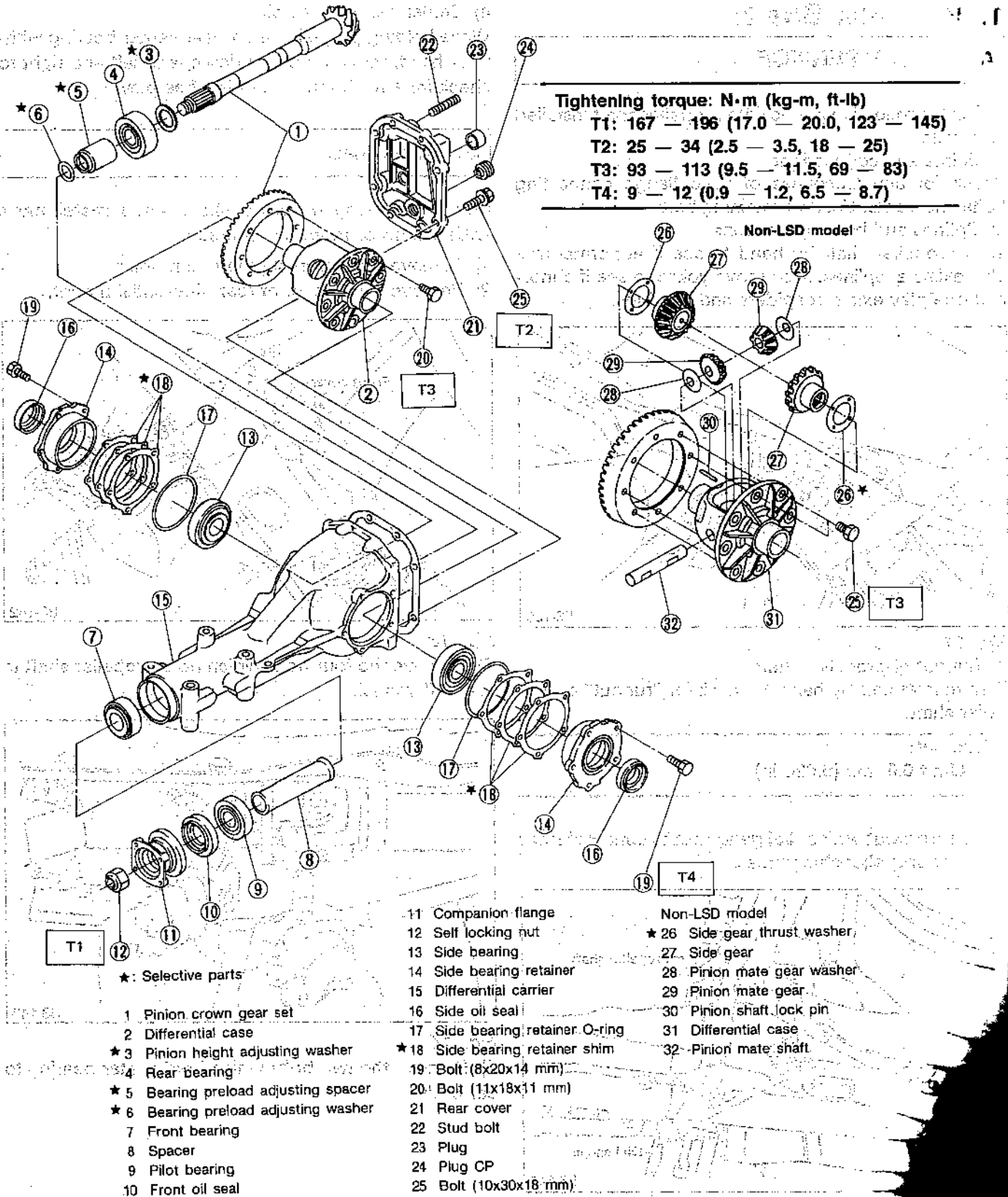


Fig. 10

W SERVICE PROCEDURE

1. Propeller Shaft

A: ON-CAR SERVICE

Check the following points with propeller shaft installed in vehicle.

1) Joints and connections

Check for any looseness of yoke flange connecting bolts and center bearing retaining bolts.

2) Splines and bearing locations

Turn propeller shaft by hand to see if abnormal free play exists at splines. Also move yokes to see if abnormal free play exists at spiders and bearings.

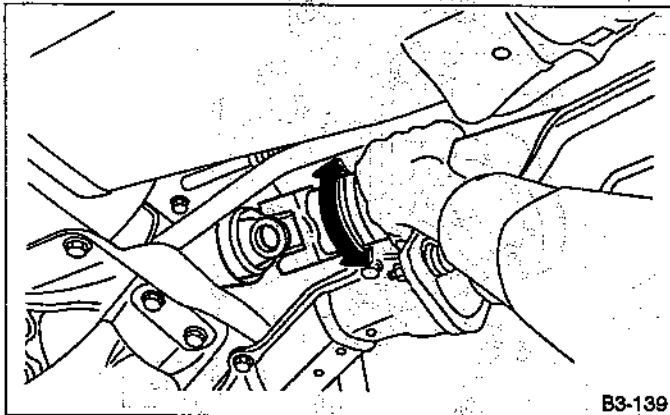


Fig. 11

3) Runout of propeller shaft

Turn rear wheels by hand to check for "runout" of propeller shaft.

Run out:

Limit 0.6 mm (0.024 in)

Measure runout with a dial gauge at the center of front and rear propeller shaft tubes.

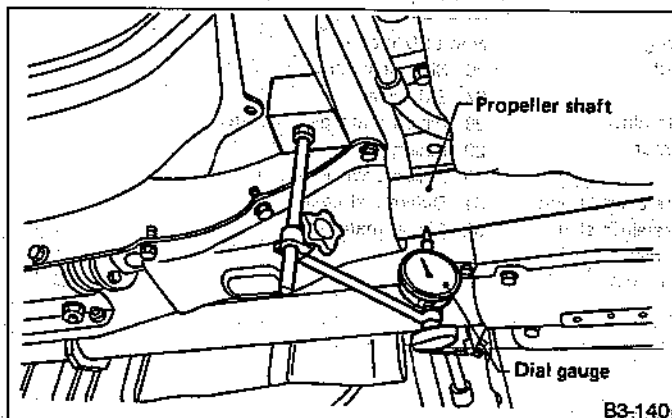


Fig. 12

4) Center bearing free play

While holding propeller shaft near center bearing with your hand, move it up and down, and left and right to check for any abnormal bearing free play.

B: REMOVAL

Before removing propeller shaft, wrap metal parts with a cloth or rubbered material.

1) Remove rear exhaust pipe and muffler.

2) Remove front cover of rear differential mount.

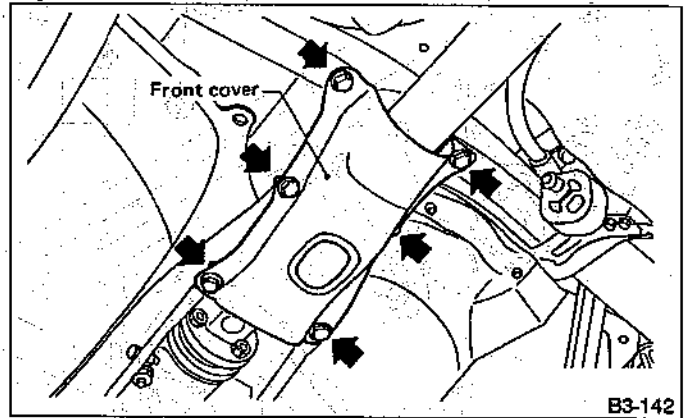


Fig. 13

3) Remove the four bolts which hold propeller shaft to rear differential.

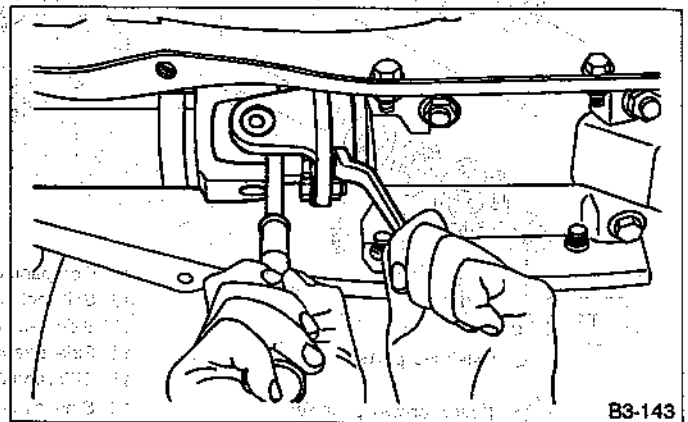


Fig. 14

4) Remove the two bolts which hold center bearing to car body.

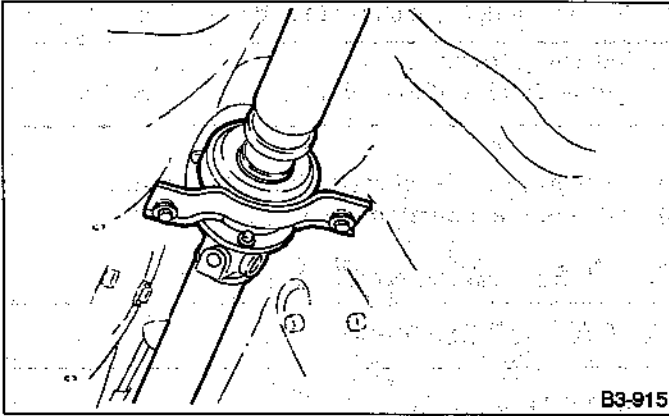


Fig. 15

5) Remove propeller shaft from transmission.

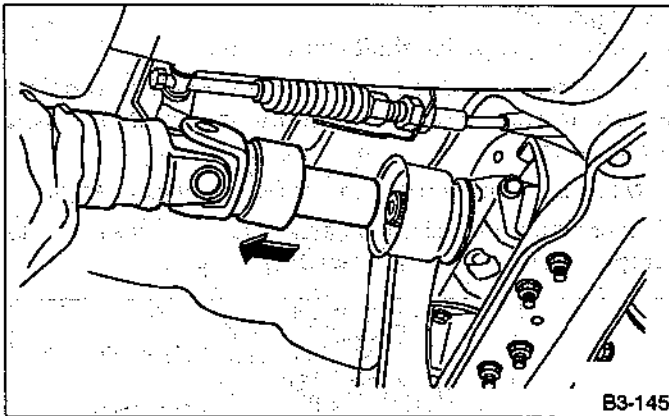


Fig. 16

- a. Be sure to use an empty oil can to catch oil flowing out when removing propeller shaft.
- b. Be sure not to damage oil seals and the frictional surface of sleeve yoke.
- c. Be sure to plug the opening in transmission after removal of propeller shaft.

C: DISASSEMBLY

Before removing center bearing, check its condition. If it does not operate smoothly or if there is any free play or leakage, remove as follows:

1) Put aligning marks on affected parts.

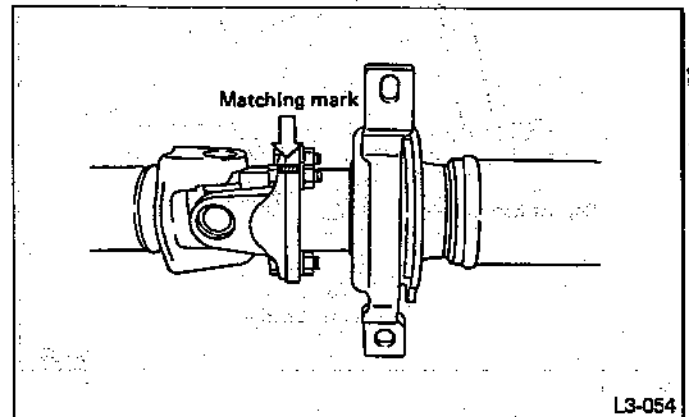


Fig. 17

- 2) Remove bolts which hold front propeller shaft to rear propeller shaft.
 - 3) Place companion flange in a vise and remove stake nut.
- Be sure not to hold propeller shaft pipe portion in the vise.

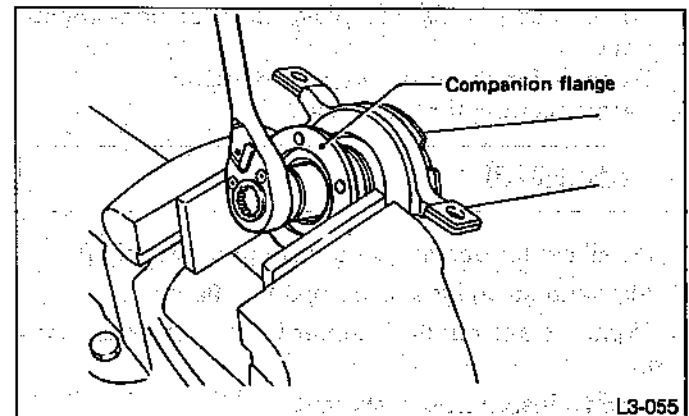


Fig. 18

- 4) Drive out companion flange with a puller or press. Before disassembling, put alignment mark on affected parts.
- 5) Lightly tap the head of front propeller shaft with a copper hammer until center bearing is removed. Be careful not to damage the thread portion.

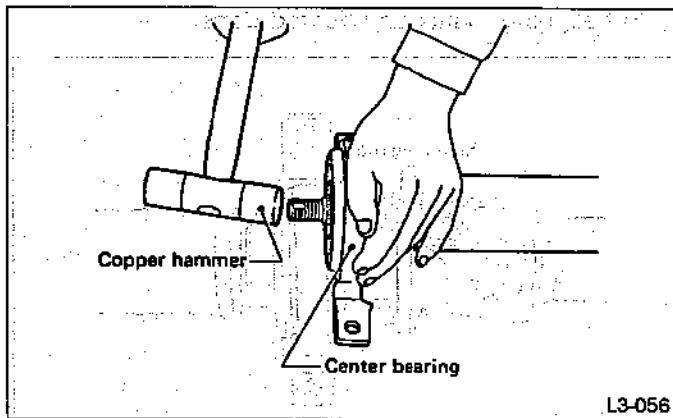


Fig. 19

D: INSPECTION

Do not disassemble propeller shaft. Check the following and replace if necessary.

- 1) Tube surfaces for dents or cracks
- 2) Splines for deformation or abnormal wear
- 3) Joints for non-smooth operation or abnormal noise
- 4) Center bearing for free play, noise or non-smooth operation
- 5) Oil seals for abnormal wear or damage
- 6) Center bearing for breakage

E: ASSEMBLY

- 1) Install center bearing onto front propeller shaft.
- 2) Align marks and install companion flange.
- 3) Tighten stake nut until center bearing is set in position.

Be sure to install new stake nut.

Tightening torque:

245 — 294 N·m (25 — 30 kg-m, 181 — 217 ft-lb)

Stake the nut after tightening.

- 4) Align marks and connect front and rear propeller shafts.

Tightening torque:

24 — 32 N·m (2.4 — 3.3 kg-m, 17 — 24 ft-lb)

F: INSTALLATION

- 1) Insert sleeve yoke into transmission and attach center bearing to car body.

Tightening torque:

47 — 57 N·m (4.8 — 5.8 kg-m, 35 — 42 ft-lb)

- 2) Connect flange yoke and rear differential.

Tightening torque:

24 — 39 N·m (2.4 — 4.0 kg-m, 17 — 29 ft-lb)

- 3) Install front cover of rear differential mount.
- 4) Install rear exhaust pipe and muffler.

2. Rear Differential**A: ON-CAR SERVICE****1. FRONT OIL SEAL**

- 1) Drain gear oil.
- 2) Jack up rear wheels and support the vehicle body with rigid racks.
- 3) Remove propeller shaft from body.

Wrap metal parts with a cloth or rubbered material to prevent it from damage by interference with adjacent metal parts.

- 4) Measure turning resistance of companion flange.

Measure turning resistance after making sure that the companion flange turns smoothly.

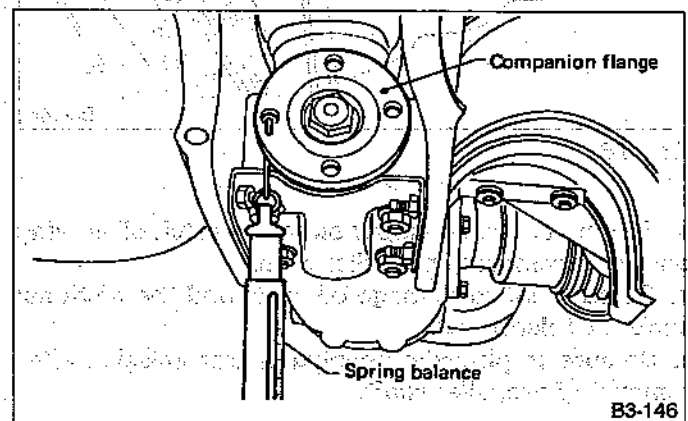


Fig. 20

- 5) Remove self-locking nut while holding companion flange with FLANGE WRENCH:

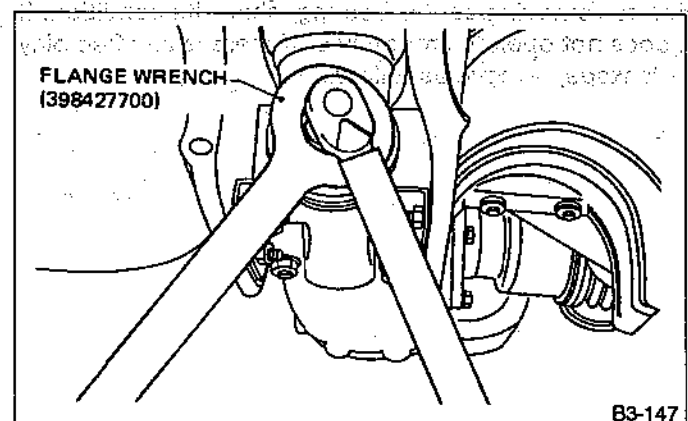


Fig. 21

- 6) Extract companion flange with a puller.
- 7) Remove oil seal.

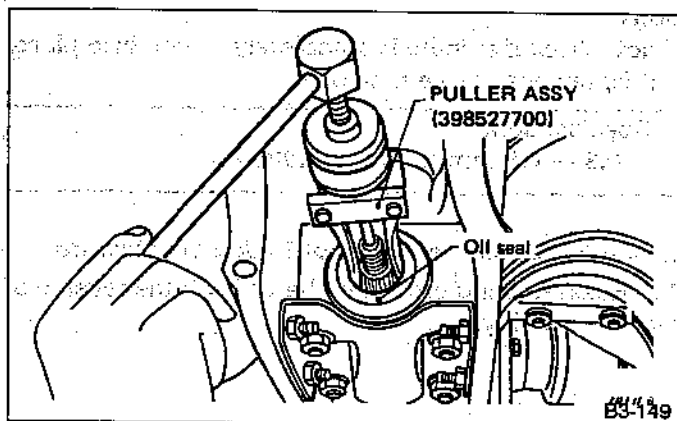


Fig. 22

- 8) Fit a new oil seal.

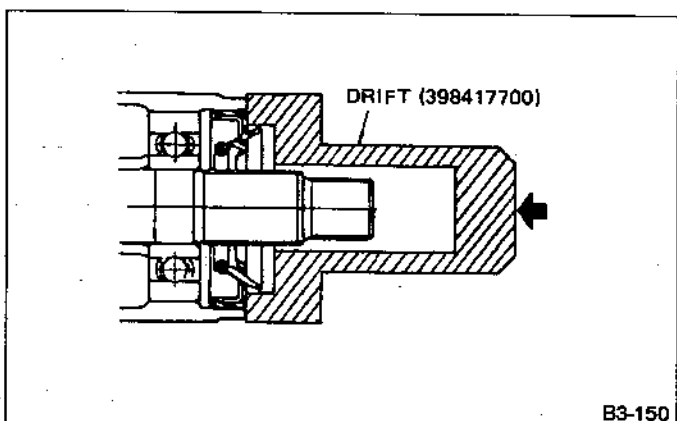


Fig. 23

- 9) Install companion flange.
- 10) Tighten self-locking nut within the specified torque range so that the turning resistance of companion flange becomes the same as that before replacing oil seal.

Torque (Drive pinion nut):

167 — 196 N·m

(17.0 — 20.0 kg-m, 123 — 145 ft-lb)

- 11) Reassembling procedure hereafter is the reverse of the disassembling.

2. SIDE OIL SEAL

- 1) Loosen both wheel nuts.
- 2) Jack up the vehicle and support it with rigid racks.
- 3) Remove wheels.
- 4) Remove bolt connecting lateral link to rear housing.

Do not reuse self locking nut.

- 5) Remove bolt connecting trailing link to rear housing.

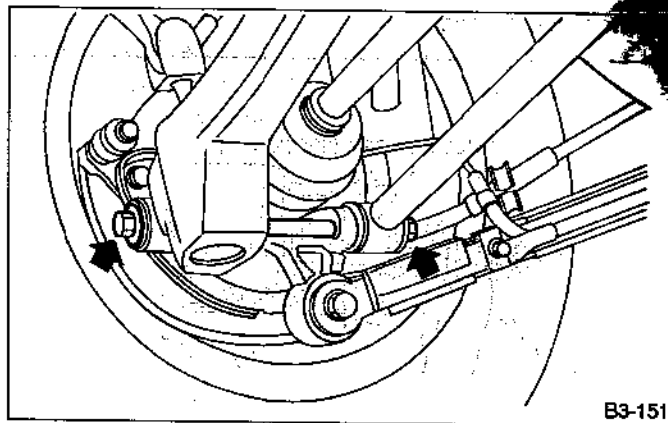
Do not reuse self locking nut.

Fig. 24

- 6) Drive out spring pin from DOJ of rear drive shaft by using 6 mm (0.24 in) diameter steel rod.

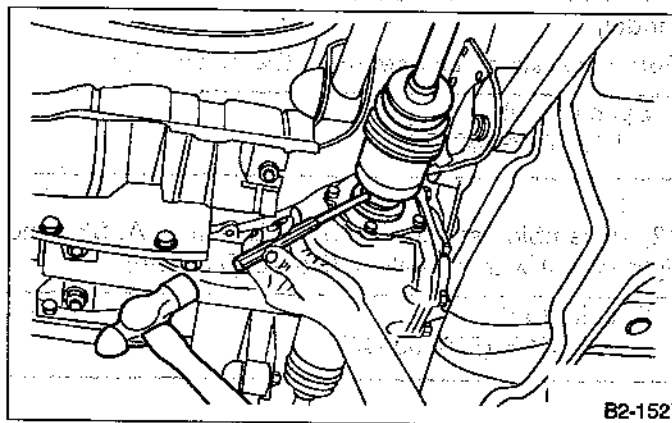


Fig. 25

- 7) Remove the DOJ from rear differential spindle while pushing rear housing outward. Suspend removed drive shaft using a wire.

- 8) Loosen differential spindle set bolt by using WRENCH and remove spindle with packing. (Non-LSD model)

Special tool:

WRENCH (925560000)

- 9) Remove spindle using REMOVER and INSTALLER. (LSD model)

Special tool:

REMOVER (499095500)

INSTALLER (499247300)

10) Remove oil seal.

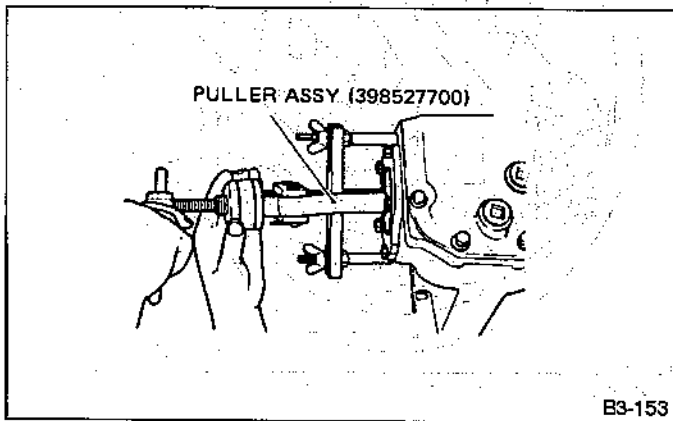


Fig. 26

11) Drive in a new oil seal with DRIFT. (Non-LSD model)

Apply chassis grease between the oil seal lips.

Special tool:

DRIFT (398437700)

12) Assemble spindle into differential ASSY and tighten bolt with WRENCH. (Non-LSD model)

Special tool:

WRENCH (925560000)

13) After assembling circlip on spindle, set spindle into differential and install by hitting it with a plastic hammer. (LSD model)

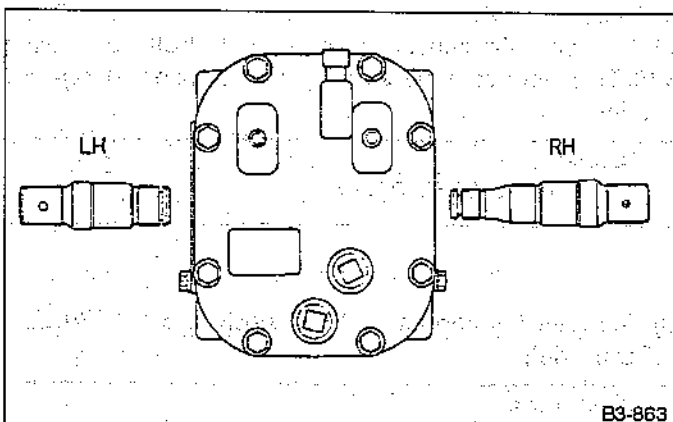


Fig. 27

a. Always use a new circlip.

b. Check that spindle thrust play is within specifications.

If not, check if spindle is completely driven into place. If it is, replace with a new one.

Specifications:

0.3 — 0.5 mm (0.012 — 0.020 in)

c. Check that oil seal lip is not folded over inward.

14) Reassembling procedure hereafter is the reverse of the disassembly.

B: IDENTIFICATION

Using the different rear differential ASSY causes the drive line and tires to "drag" or emit abnormal noise when 4WD is selected.

When replacing a rear differential ASSY, select the correct one according to the following table.

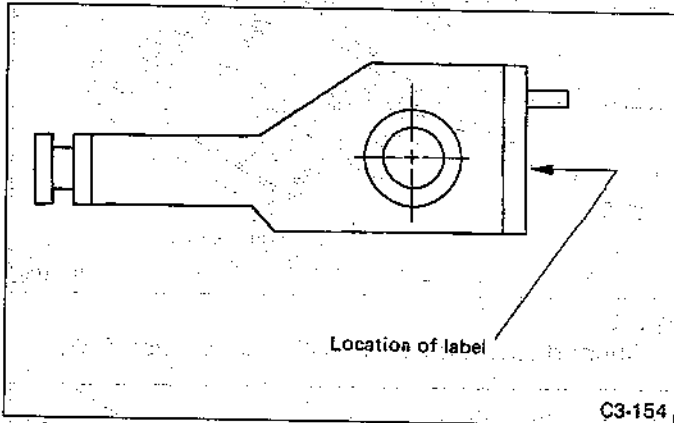


Fig. 28

Gear ratio	Identification mark	Part number	Label stuck on rear differential
3.545	JQ	27011AA230	PART NUMBER 27011AA230 VISCOUS LSD GEAR RATIO 3.545 ● FUJI HEAVY INDUSTRIES LTD. JQ
3.900	W2	27011AA151	PART NUMBER 27011AA151 GEAR RATIO 3.900 ● FUJI HEAVY INDUSTRIES LTD. W2
4.111	W3	27011AA111	PART NUMBER 27011AA111 GEAR RATIO 4.111 ● FUJI HEAVY INDUSTRIES LTD. W3
4.444	W4	27011AA121	PART NUMBER 27011AA121 GEAR RATIO 4.444 ● FUJI HEAVY INDUSTRIES LTD. W4

Fig. 29

C: REMOVAL

- 1) Remove rear exhaust pipe and muffler.
- 2) Remove front cover of rear differential mount.

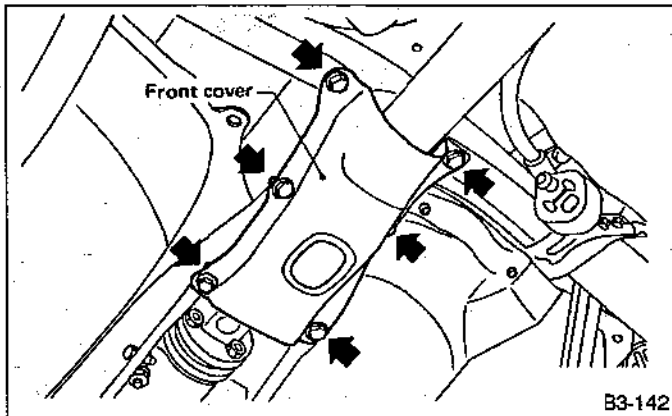


Fig. 30

- 3) Remove propeller shaft.
 - a. Prepare an oil can and cap since the transmission oil flows out from the extension at removing propeller shaft.
 - b. When removing propeller shaft, pay attention not to damage the sliding surfaces of rear drive shaft (extension) spline, oil seal and sleeve yoke.
 - c. Insert the cap into the extension to prevent transmission oil from flowing out immediately after removing the propeller shaft.
- 4) Remove spring pins from DOJ of rear drive shafts.
- 5) Remove heat sealed cover.
- 6) Remove clamps and bracket of parking brake cable.

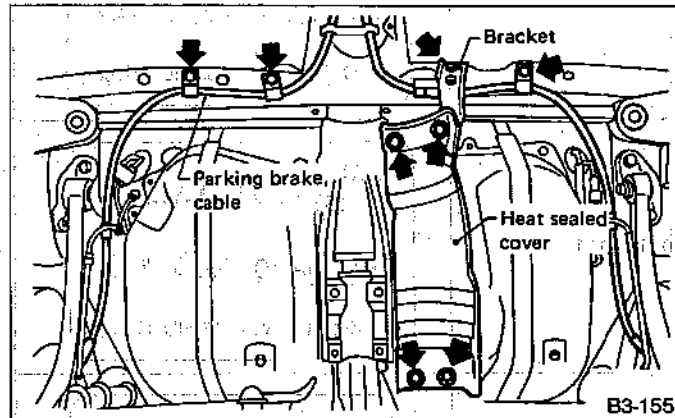


Fig. 31

- 7) Remove lower differential bracket.

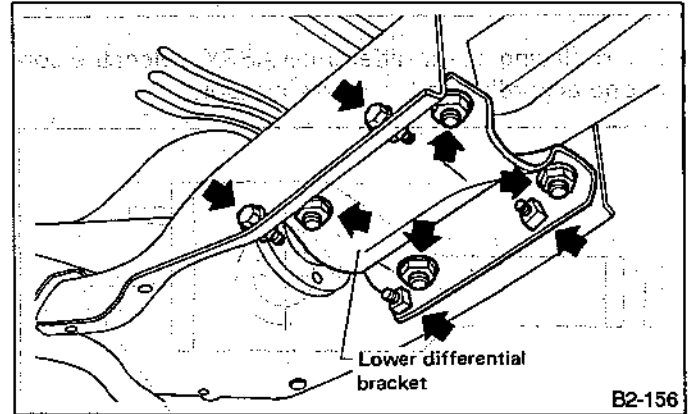


Fig. 32

- 8) Support rear differential with transmission jack.

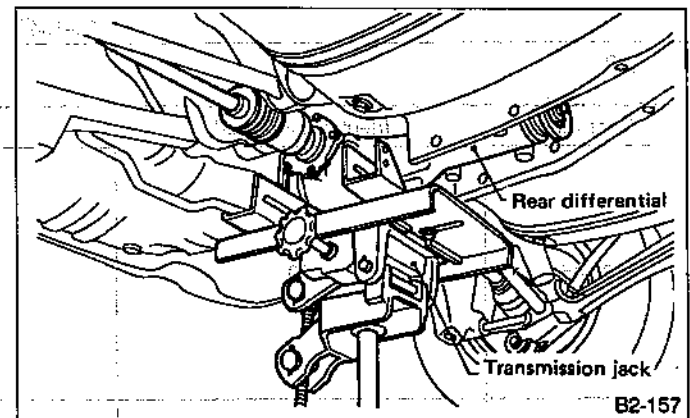


Fig. 33

- 9) Remove self-locking nuts connecting rear differential to rear member.

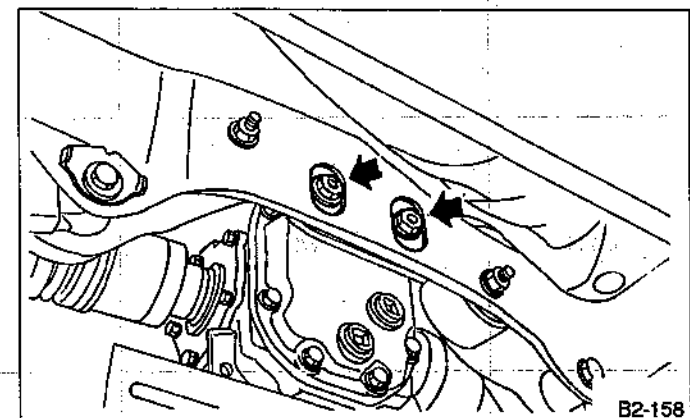


Fig. 34

10) Remove bolts which secure rear differential front member to body.

Loosen bolt ① first, then removal bolts ②.

Support front member with the use of a helper to prevent it from dropping.

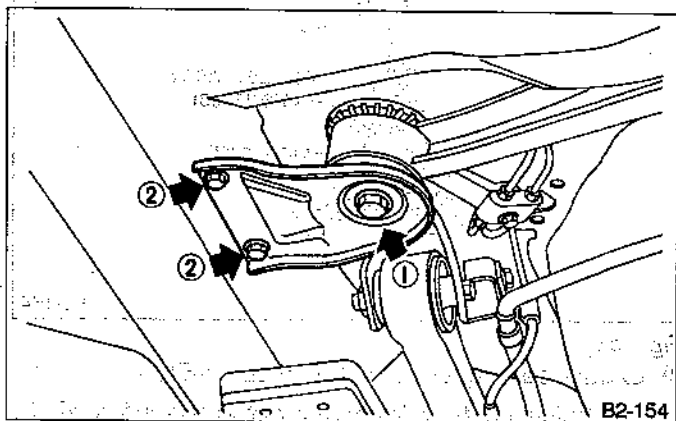


Fig. 35

11) While slowly lowering transmission jack, move rear differential forward and remove bolts from rear member.

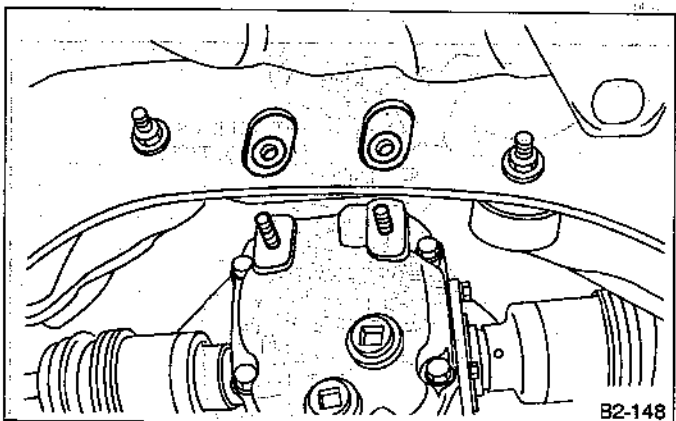


Fig. 36

12) Remove front member from body.

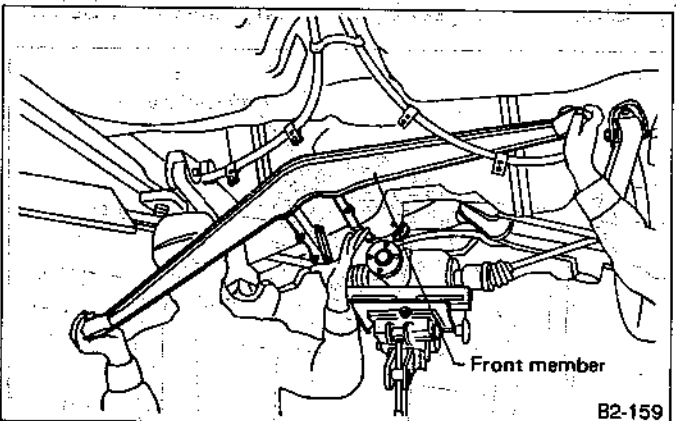


Fig. 37

13) Remove rear drive shaft from rear differential, and remove rear differential from body.

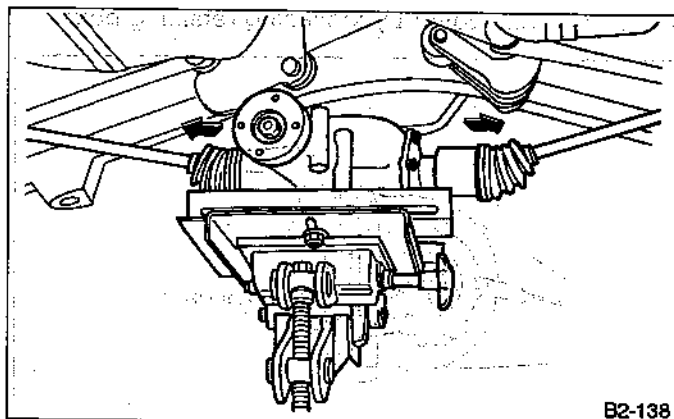


Fig. 38

D: DISASSEMBLY

To detect real cause of trouble, inspect the following items before disassembling. (Refer to "ASSEMBLY" for inspection procedures.)

- Tooth contact of hypoid drive gear and pinion, and backlash
- Runout of drive gear at its back surface
- Turning resistance of drive pinion

1) Set ATTACHMENT on vise and install the differential assembly to Attachment.

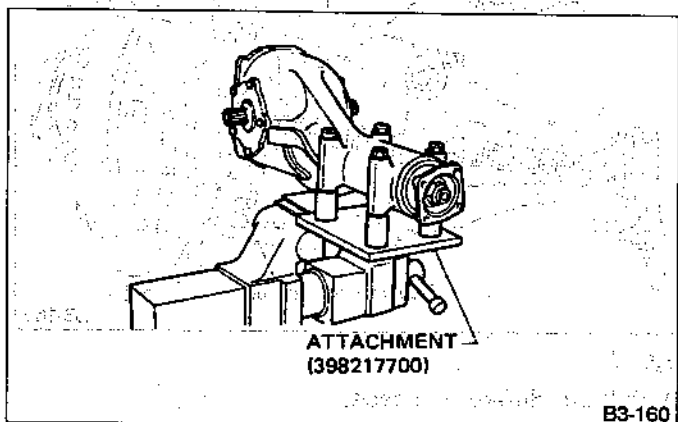


Fig. 39

- 2) Drain gear oil by removing plug.
- 3) Remove spindles with special tool.

Special tool:

- Non-LSD model
WRENCH (925560000)
- LSD model
REMOVER (499095500)
INSTALLER (499247300)

4) Remove rear cover by loosening retaining bolts.

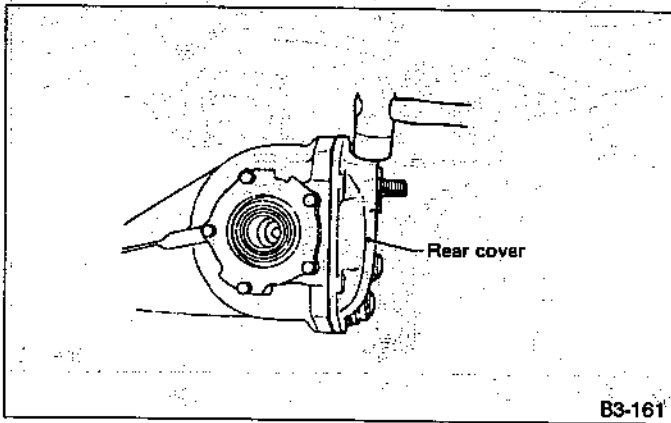


Fig. 40

5) Make right and left side bearing retainers in order to identify them at reassembly. Remove side bearing retainer attaching bolts, set ATTACHMENT to differential case, and extract right and left side bearing retainers with a puller.

Each shim, which is installed to adjust the side bearing preload, should be kept together with its mating retainer.

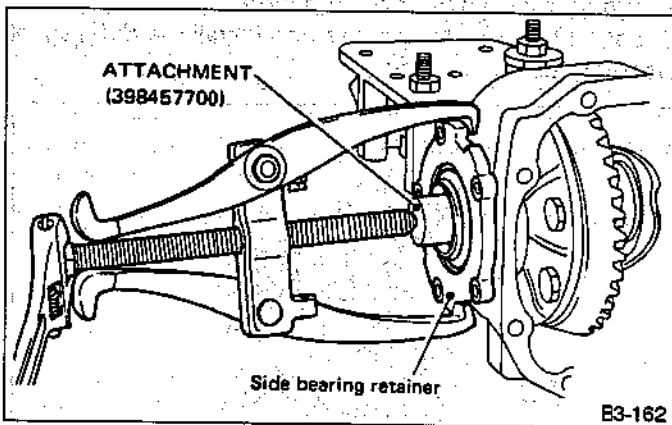


Fig. 41

6) Pull out differential case.

Be careful not to permit the teeth to contact the case.

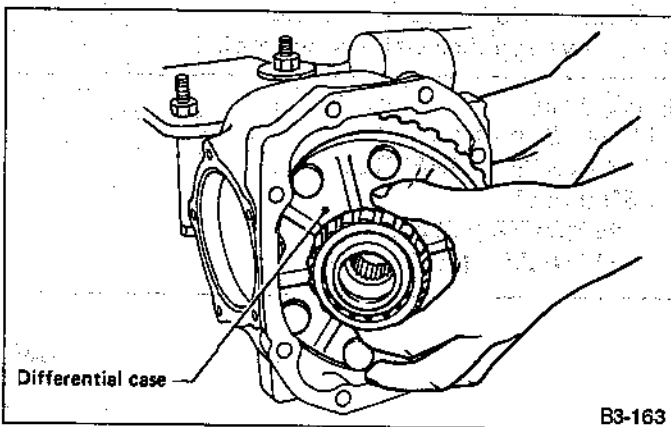


Fig. 42

7) When replacing side bearing, pull bearing cup from side bearing retainer.

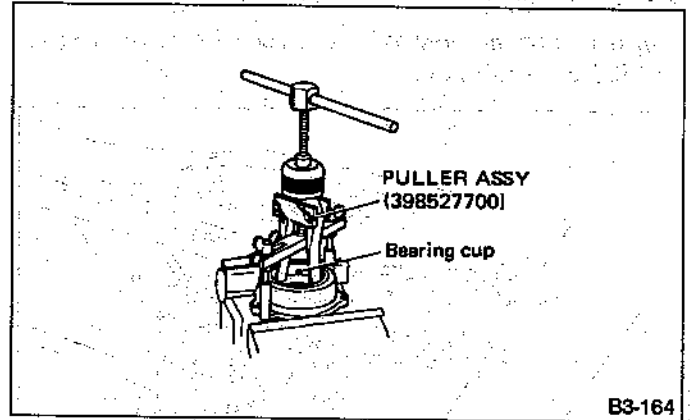


Fig. 43

8) Extract bearing cone with PULLER SET.

a. Set Puller so that its claws catch the edge of the bearing cone.

b. Never mix up the right and left hand bearing cups and cones.

Do not attempt to disassemble the parts unless necessary.

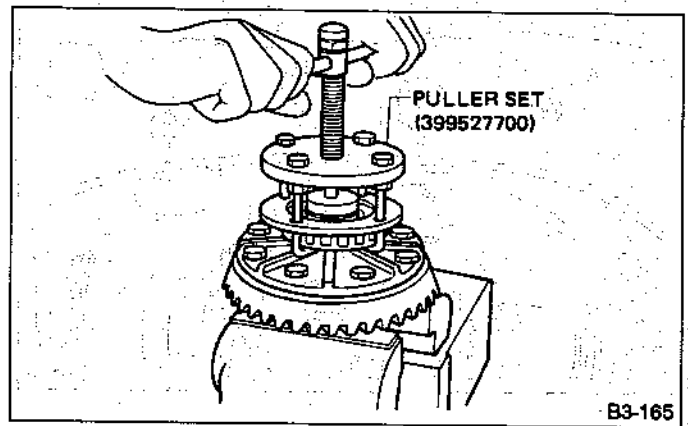


Fig. 44

9) Remove drive gear by loosening drive gear bolts.

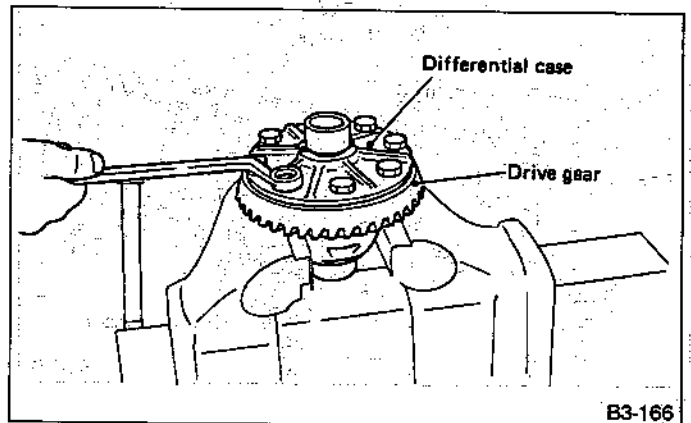
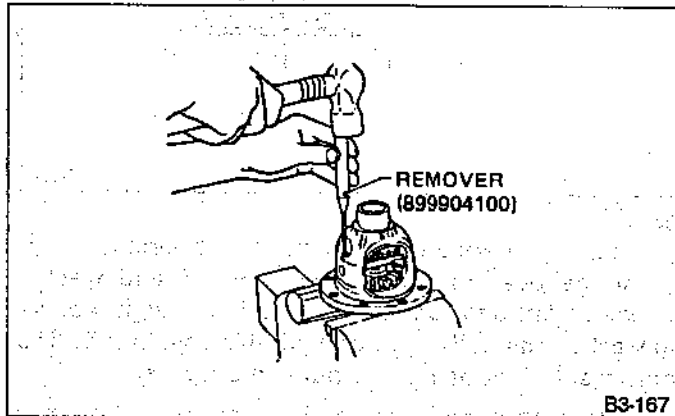


Fig. 45

Further disassembling of viscous LSD ASSY is not allowed.

10) Drive out pinion shaft lock pin from drive gear side. The lock pin is staked at the pin hole end on the differential carrier; do not drive it out forcibly before uns-taking it.



B3-167

Fig. 46

11) Draw out pinion mate shaft and remove pinion mate gears, side gears and thrust washers.

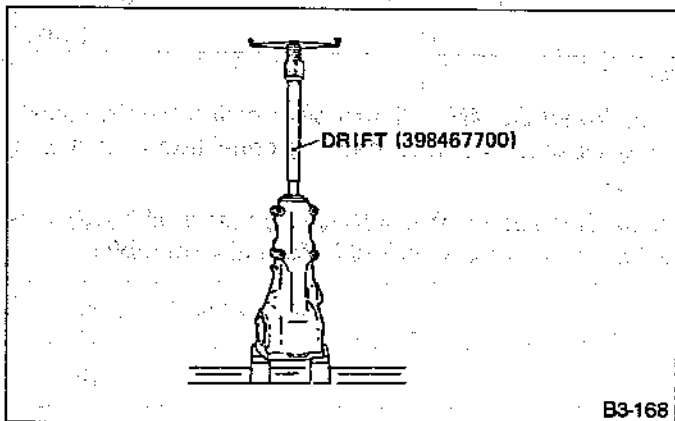
The gears as well as thrust washers should be marked or kept separated left and right, and front and rear.

12) Hold companion flange with FLANGE WRENCH and remove drive pinion nut.

13) Extract the companion flange with a puller.

14) Press the end of drive pinion shaft and extract it together with rear bearing cone, preload adjusting spacer and washer.

Hold the drive pinion so as not to drop it.

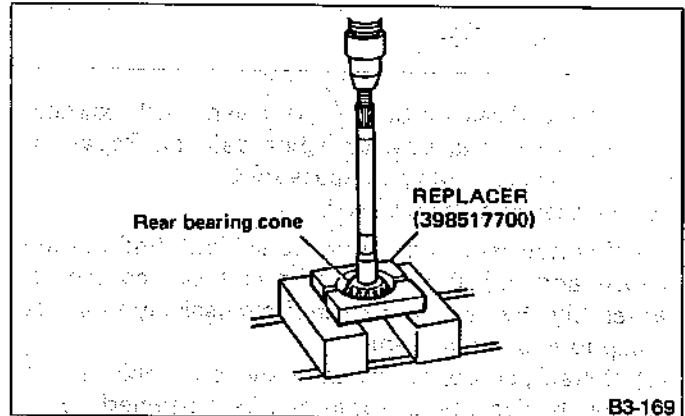


B3-168

Fig. 47

15) Remove rear bearing cone from drive pinion by supporting cone with REPLACER.

Place the replacer so that its center-recessed side faces the pinion gear.

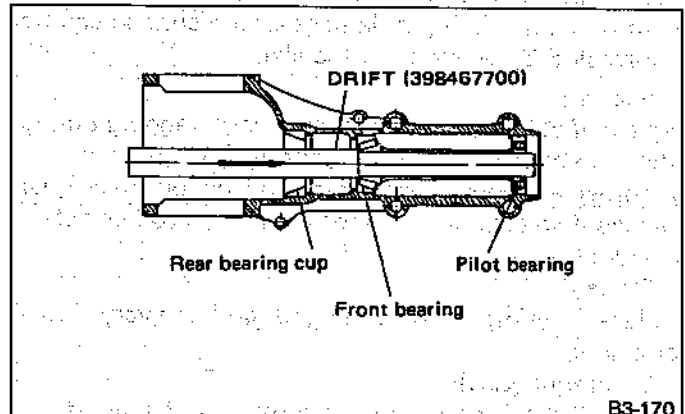


B3-169

Fig. 48

16) Remove front oil seal from differential carrier.

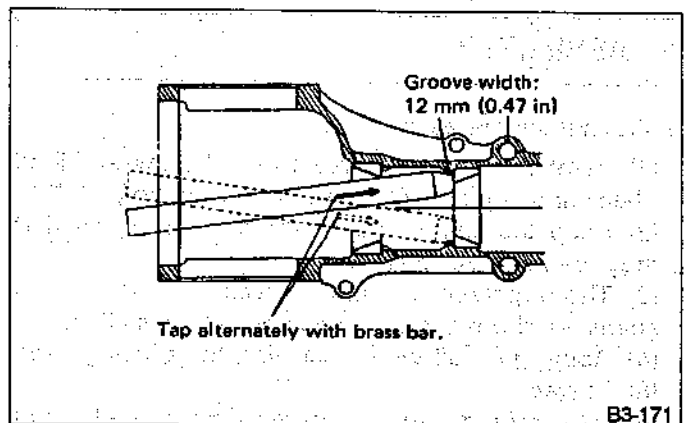
17) Remove pilot bearing together with front bearing cone.



B3-170

Fig. 49

18) When replacing bearings, tap front bearing cup and rear bearing cup in this order out of case by using a brass bar.



B3-171

Fig. 50

E: INSPECTION

Wash all the disassembled parts clean, and examine them for wear, damage, or other defects. Repair or replace defective parts as necessary.

1) Drive gear and drive pinion

(1) If abnormal tooth contact is evident, find out the cause and adjust to give correct tooth contact at assembly. Replace the gear if excessively worn or incapable of adjustment.

(2) If crack, score, or seizure is evident, replace as a set. Slight damage of tooth can be corrected by oil stone or the like.

2) Side gear and pinion mate gear

(1) Replace if crack, score, or other defects are evident on tooth surface.

(2) Replace if thrust washer contacting surface is worn or seized. Slight damage of the surface can be corrected by oil stone or the like.

3) Bearing

Replace if seizure, peeling, wear, rust, dragging during rotation, abnormal noise or other defect is evident.

4) Thrust washers of side gear and pinion mate gear
Replace if seizure, flaw, abnormal wear or other defect is evident.

5) Oil seal

Replace if deformed or damaged, and at every disassembling.

6) Differential carrier

Replace if the bearing bores are worn or damaged.

7) Differential case

Replace if its sliding surfaces are worn or cracked.

8) Companion flange

Replace if the oil seal lip contacting surfaces have flaws.

F: ASSEMBLY

1) Precautions for assembling

(1) Assemble in the reverse order of disassembling. Check and adjust each part during assembly.

(2) Keep the shims and washers in order, so that they are not misinstalled.

(3) Thoroughly clean the surfaces on which the shims, washers and bearings are to be installed.

(4) Apply gear oil when installing the bearings and thrust washers.

(5) Be careful not to mix up the right and left hand cups of the bearings.

(6) Replace the oil seal with new one at every disassembly. Apply chassis grease between the lips (*) when installing the oil seal.

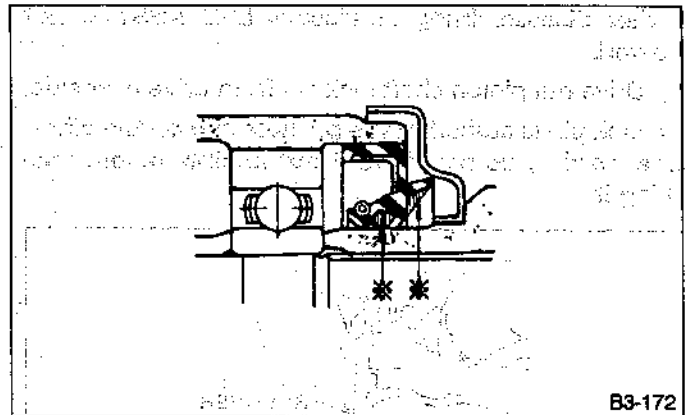


Fig. 51

2) Adjusting preload for front and rear bearings.

Adjust the bearing preload with spacer and washer between front and rear bearings. Pinion height adjusting washer has nothing to do with this adjustment. The adjustment must be carried out without oil seal.

(1) Press front and rear bearing cups into differential carrier.

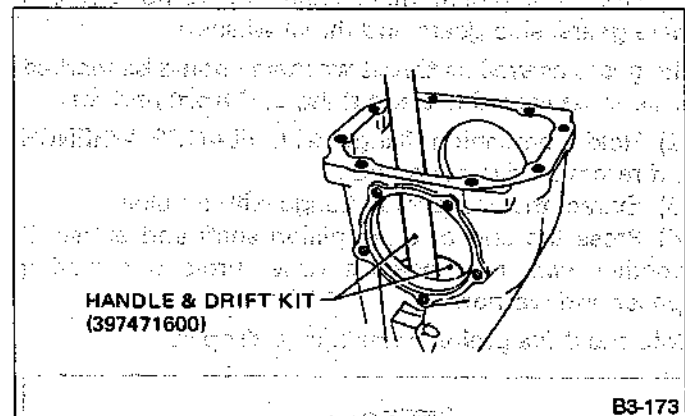


Fig. 52

(2) Insert DUMMY SHAFT with pinion height adjusting washer and rear bearing cone fitted on it into case.

Reuse the used washer if they show normal tooth contact pattern when checked before disassembly.

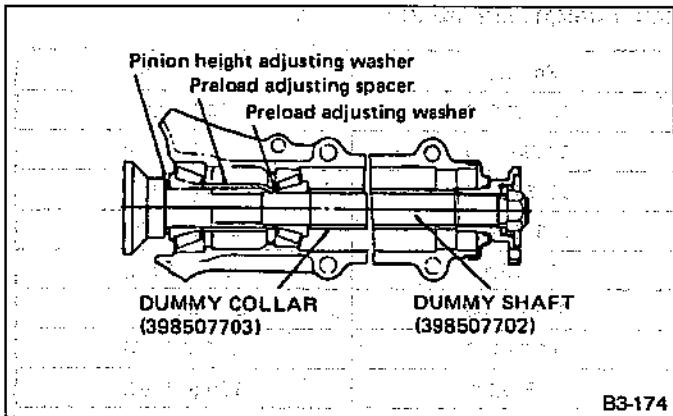


Fig. 53

(3) Then, install preload adjusting spacer and washer, front bearing cone, DUMMY COLLAR, companion flange, washer and drive pinion nut.
 (4) Turn Dummy Shaft with hand to make it seated, and tighten drive pinion nut while measuring the preload with spring balance as shown in the figure. Select preload adjusting washer and spacer so that the specified preload is obtained when nut is tightened to the specified torque.

- a. Be careful not to give excessive preload.
- b. When tightening the drive pinion nut, lock Dummy Shaft with BLOCK as illustrated here.

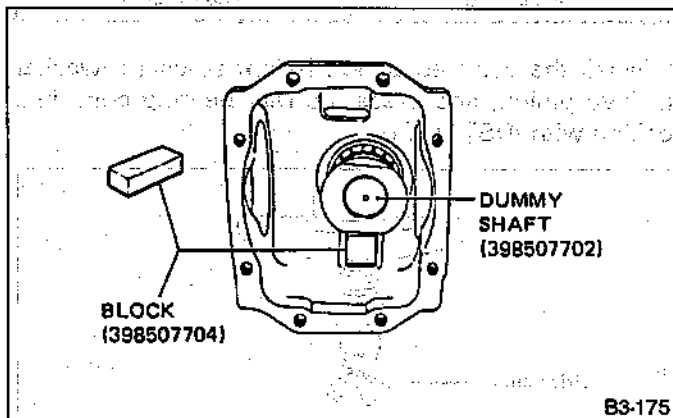


Fig. 54

Torque (Drive pinion nut):
 167 — 196 N·m (17.0 — 20.0 kg·m, 123 — 145 ft·lb)

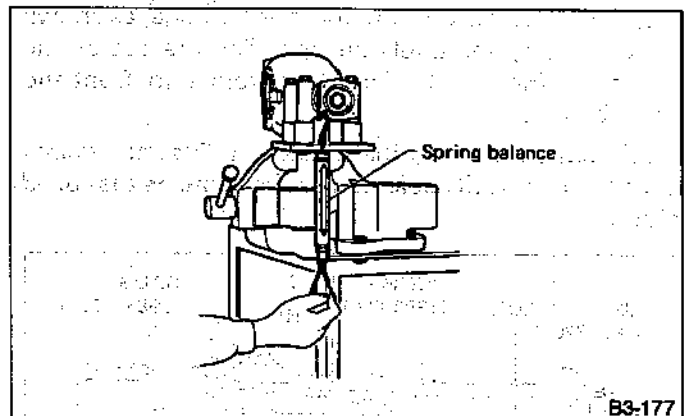


Fig. 55

Front & rear bearing preload	
For new bearing:	19.6 — 28.4 N (2.0 — 2.9 kg, 4.4 — 6.4 lb) at companion flange bolt hole
For used bearing:	8.34 — 16.67 N (0.85 — 1.7 kg, 1.87 — 3.75 lb) at companion flange bolt hole

Preload adjusting washers

Part No.	Length mm (in)
383705200	2.59 (0.1020)
383715200	2.57 (0.1012)
383725200	2.55 (0.1004)
383735200	2.53 (0.0996)
383745200	2.51 (0.0988)
383755200	2.49 (0.0980)
383765200	2.47 (0.0972)
383775200	2.45 (0.0965)
383785200	2.43 (0.0957)
383795200	2.41 (0.0949)
383805200	2.39 (0.0941)
383815200	2.37 (0.0933)
383825200	2.35 (0.0925)
383835200	2.33 (0.0917)
383845200	2.31 (0.0909)

Preload adjusting spacers

Part No.	Length mm (in)
383695201	56.2 (2.213)
383695202	56.4 (2.220)
383695203	56.6 (2.228)
383695204	56.8 (2.236)
383695205	57.0 (2.244)
383695206	57.2 (2.252)

3) Adjusting drive pinion height
 Adjust drive pinion height with washer installed between rear bearing cone and the back of pinion gear.

(1) Install Dummy Shaft, Collar and Gauge, as shown in the figure, and apply the specified preload on the bearings. (Refer to 2.) Adjusting preload for front and rear bearings.

At this time, install a pinion height adjusting washer which is temporarily selected or the same as that used before.

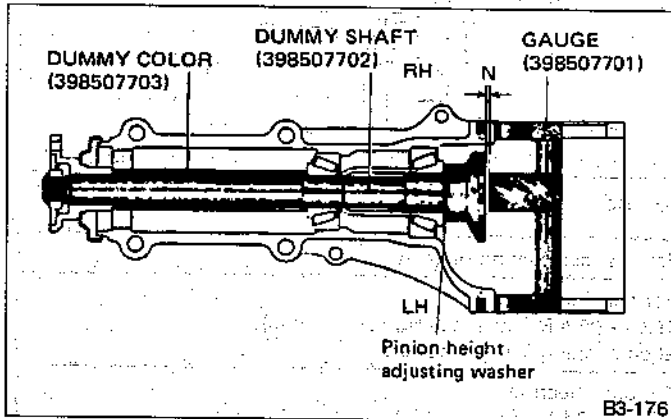


Fig. 56

(2) Measure the clearance N between the end of Gauge and the end surface of Dummy Shaft by using a thickness gauge.

Make sure there is no clearance between the case and Gauge.

(3) Obtain the thickness of pinion height adjusting washer to be inserted from the following formula, and replace the temporarily installed washer with this one.

$$T = T_o + N - (H \times 0.01) - 0.20 \text{ (mm)}$$

where

T = Thickness of pinion height adjusting washer (mm)

T_o = Thickness of washer temporarily inserted (mm)

N = Reading of thickness gauge (mm)

H = Figure marked on drive pinion head

(Example of calculation)

$$T_o = 2.20 + 1.20 = 3.40 \text{ mm}$$

$$N = 0.23 \text{ mm } H = +1$$

$$T = 3.40 + 0.23 - 0.01 - 0.20 = 3.42$$

Result: Thickness = 3.42 mm

Therefore use the washer 383605200.

Pinion height adjusting washers

Part No.	Thickness mm (in)
383495200	3.09 (0.1217)
383505200	3.12 (0.1228)
383515200	3.15 (0.1240)
383525200	3.18 (0.1252)
383535200	3.21 (0.1264)
383545200	3.24 (0.1276)
383555200	3.27 (0.1287)
383565200	3.30 (0.1299)
383575200	3.33 (0.1311)
383585200	3.36 (0.1323)
383595200	3.39 (0.1335)
383605200	3.42 (0.1346)
383615200	3.45 (0.1358)
383625200	3.48 (0.1370)
383635200	3.51 (0.1382)
383645200	3.54 (0.1394)
383655200	3.57 (0.1406)
383665200	3.60 (0.1417)
383675200	3.63 (0.1429)
383685200	3.66 (0.1441)

4) Install the selected pinion height adjusting washer on drive pinion, and press the rear bearing cone into position with INSTALLER.

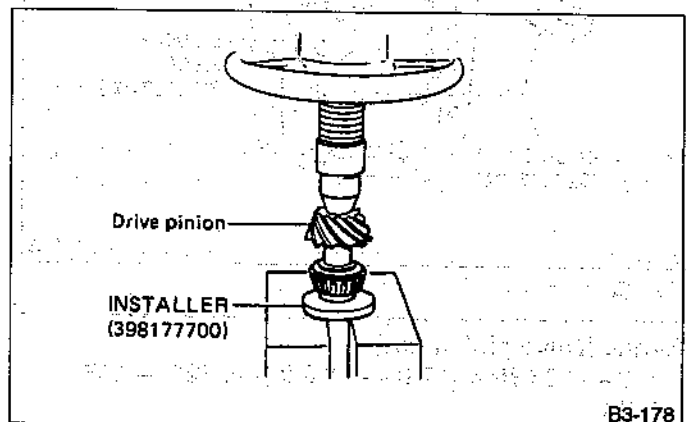


Fig. 57

5) Insert drive pinion into differential carrier, install the previously selected preload adjusting spacer and washer.

6) Press-fit front bearing cone into case.

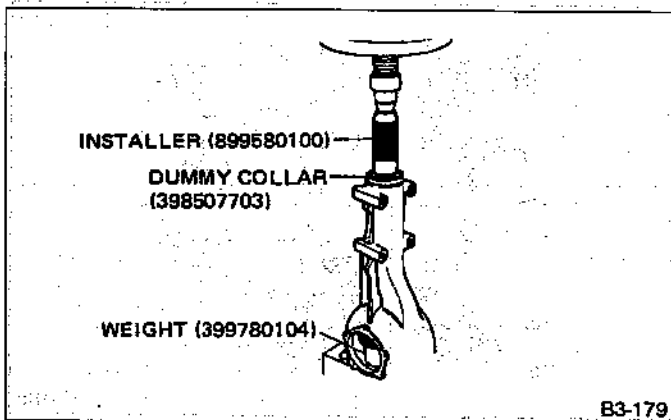


Fig. 58

7) Insert spacer, then press-fit pilot bearing with WEIGHT and INSTALLER.

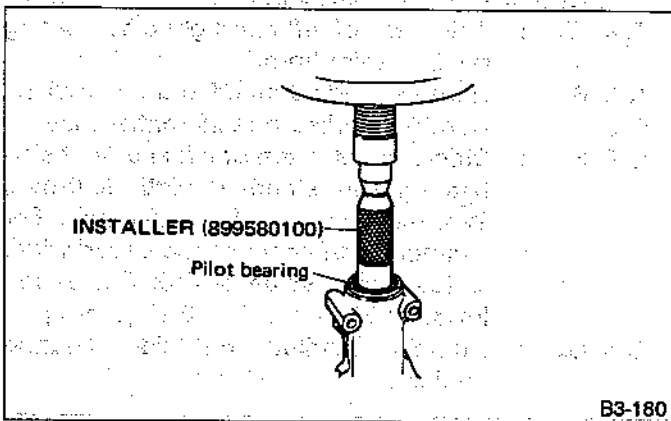


Fig. 59

8) Fit a new oil seal with DRIFT. Apply grease between the oil seal lips. (Refer to 1.) Precautions for assembling.

Special tool:
DRIFT (398417700)

9) Press-fit companion flange with INSTALLER and WEIGHT.

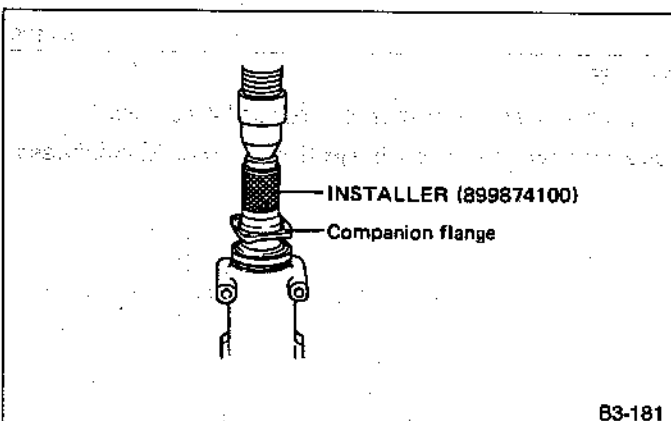


Fig. 60

10) Install self-locking nut with washer.

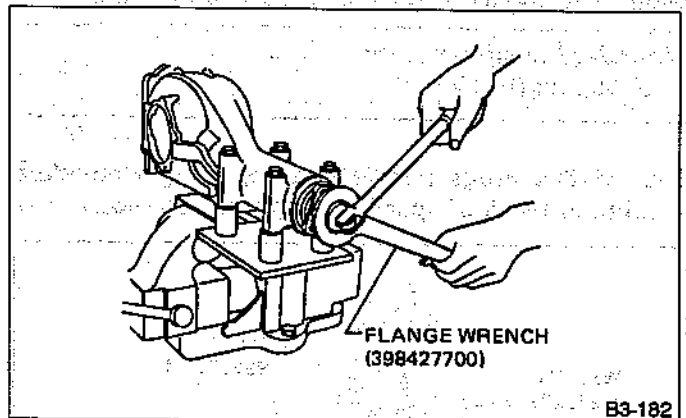


Fig. 61

Torque (Drive pinion nut):

167 — 196 N·m (17.0 — 20.0 kg-m, 123 — 145 ft-lb)

11) Assembling differential case

Install side gears and pinion mate gears, with their thrust washers and pinion mate shaft, into differential case.

Apply gear oil on both sides of the washer and on the side gear shaft before installing.

Insert the pinion mate shaft into the differential case by aligning the lock pin holes.

- (1) Measure the clearance between differential case and the back of side gear.
- (2) Adjust the clearance as specified by selecting side gear thrust washer.

Side gear back clearance:

0.1 — 0.2 mm (0.004 — 0.008 in)

Side gear thrust washers

Part No.	Thickness mm (in)
383445201	0.75 — 0.80 (0.0295 — 0.0315)
383445202	0.80 — 0.85 (0.0315 — 0.0335)
383445203	0.85 — 0.90 (0.0335 — 0.0354)

(3) Check the condition of rotation after applying oil to the gear tooth surfaces and thrust surfaces.

(4) After driving in pinion shaft lock pin, stake the both sides of the hole to prevent pin from falling off.

(5) Install drive gear on differential case.

Torque (Drive gear bolt):

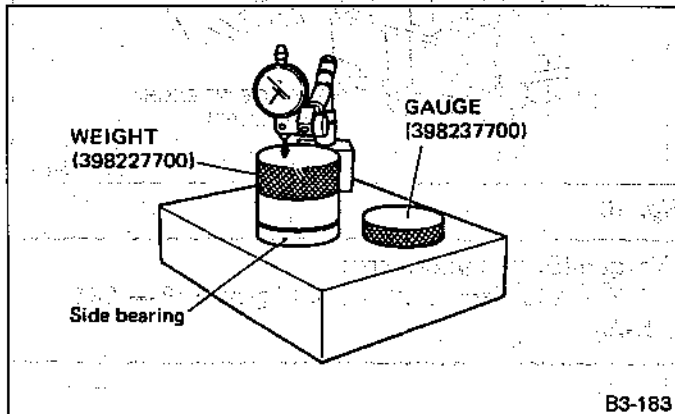
93 — 113 N·m (9.5 — 11.5 kg-m, 69 — 83 ft-lb)

Tighten diagonally while tapping the bolt heads.

12) Before installing side bearing, measure the bearing width by using a dial gauge, WEIGHT and GAUGE.

Standard bearing width:
20.00 mm (0.7874 in)

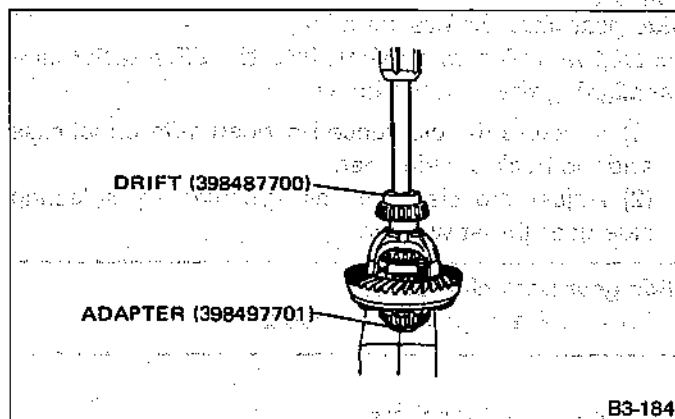
Set the dial gauge needle to zero, using a standard bearing or block of specified height in advance.



B3-183

Fig. 62

13) Press side bearing cone onto differential case with DRIFT and ADAPTER included in PULLER SET (399527700).

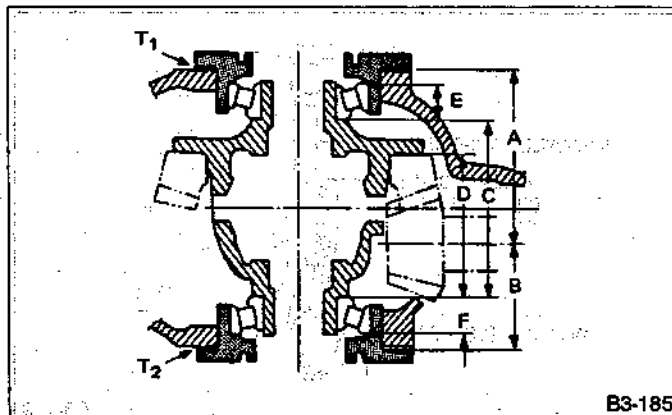


B3-184

Fig. 63

14) Adjusting side bearing retainer shims

- (1) The drive gear backlash and side bearing preload can be determined by the side bearing retainer shim thickness.
- (2) When replacing differential case, differential carrier, side bearing and side bearing retainer, obtain the right and left retainer shim thickness from the following formulas.



B3-185

Fig. 64

$$T_1 \text{ (Left)} = (A + C + G_1 - D) \times 0.01 + 0.76 - E \text{ (mm)}$$

$$T_2 \text{ (Right)} = (B + D + G_2) \times 0.01 + 0.76 - F \text{ (mm)}$$

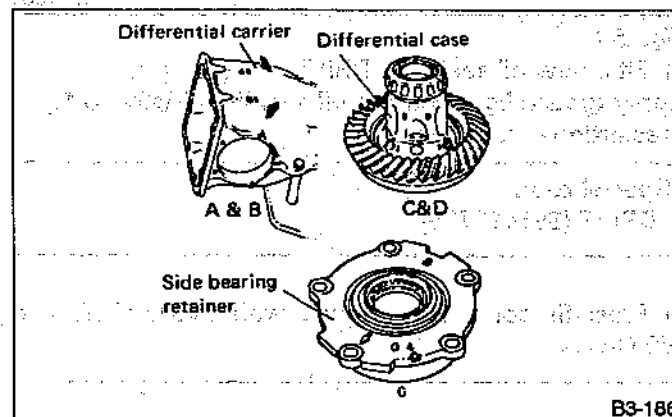
T_1 & T_2 : Thickness of left and right side bearing retainer shim (mm)

A & B : Number marked on differential carrier.

C & D : Number marked on differential case.

E & F : Difference of width of left and right side bearing from standard width 20.0 mm, expressed in a unit of 0.01 mm. For example, if the bearing measured width is 19.89 mm, value of E or F is as follows. $20.00 - 19.89 = 0.11$ (E or F)

G_1 & G_2 : Number marked on side bearing retainer.



B3-186

Fig. 65

If a number is not marked, regard it as zero.

Use several shims to obtain the calculated thickness.

Side bearing retainer shims

Part No.	Thickness mm (in)
383475201	0.20 (0.0079)
383475202	0.25 (0.0098)
383475203	0.30 (0.0118)
383475204	0.40 (0.0157)
383475205	0.50 (0.0197)

Example of calculation

Ex. 1

$$A = 5, B = 5, C = 3, D = 3, G_1 = 4, G_2 = 1, \\ E = 0.10 \text{ mm}, F = 0.15 \text{ mm}$$

Left side

$$T_1 = (A + C + G_1 - D) \times 0.01 + 0.76 - E \\ = (5 + 3 + 4 - 3) \times 0.01 + 0.76 - 0.10 \\ = 0.09 + 0.76 - 0.10 = 0.75 \text{ mm}$$

The correct shims are as follows

Thickness Q'ty

$$0.25 \times 1 = 0.25$$

$$0.50 \times 1 = 0.50$$

$$\text{Total shim thickness} = 0.75 \text{ mm}$$

Right side

$$T_2 = (B + D + G_2) \times 0.01 + 0.76 - F \\ = (5 + 3 + 1) \times 0.01 + 0.76 - 0.15 \\ = 0.09 + 0.76 - 0.15 \\ = 0.70 \text{ mm}$$

The correct shims are as follows

Thickness Q'ty

$$0.20 \times 1 = 0.20$$

$$0.50 \times 1 = 0.50$$

$$\text{Total shim thickness} = 0.70 \text{ mm}$$

Ex. 2

$$A = 2, B = 3, C = 0, D = 3, G_1 = 2, G_2 = 3, \\ E = 0.22 \text{ mm}, F = 0.10 \text{ mm}$$

Left side

$$T_1 = (A + C + G_1 - D) \times 0.01 + 0.76 - E \\ = (2 + 0 + 2 - 3) \times 0.01 + 0.76 - 0.22 \\ = 0.01 + 0.76 - 0.22 \\ = 0.55 \text{ mm}$$

The correct shims are as follows

Thickness Q'ty

$$0.25 \times 1 = 0.25$$

$$0.30 \times 1 = 0.30$$

$$\text{Total shim thickness} = 0.55 \text{ mm}$$

Right side

$$T_2 = (B + D + G_2) \times 0.01 + 0.76 - F \\ = (3 + 3 + 3) \times 0.01 + 0.76 - 0.10 \\ = 0.09 + 0.76 - 0.10 \\ = 0.75 \text{ mm}$$

The correct shims are as follows

Thickness Q'ty

$$0.25 \times 1 = 0.25$$

$$0.50 \times 1 = 0.50$$

$$\text{Total shim thickness} = 0.75 \text{ mm}$$

(3) Install the differential case ASSY into differential carrier in the reverse order of disassembling.

(4) Fit the selected shims and O-ring on side bearing retainer and install them on differential carrier with the arrow mark on the retainer directed as shown in Figure.

Be careful that side bearing cup is not damaged by bearing roller.

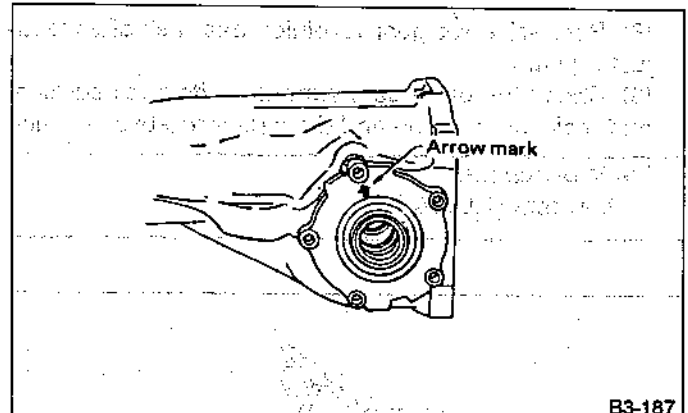


Fig. 66

(5) Tighten side bearing retainer bolts.

On vehicle with LSD, apply a coat of Three Bond 1215 (P/N 004403007) to threads.

Torque (Side bearing retainer):

$$9 - 12 \text{ N}\cdot\text{m} (0.9 - 1.2 \text{ kg}\cdot\text{m}, 6.5 - 8.7 \text{ ft}\cdot\text{lb})$$

(6) Measure the drive gear-to-drive pinion backlash. If the reading is not within the specified range, correct by decreasing the shim thickness on one side and increasing the shim thickness on the other side the same amount. Total shim thickness must be the same to maintain proper preload.

Backlash: 0.10 — 0.20 mm (0.0039 — 0.0079 in)

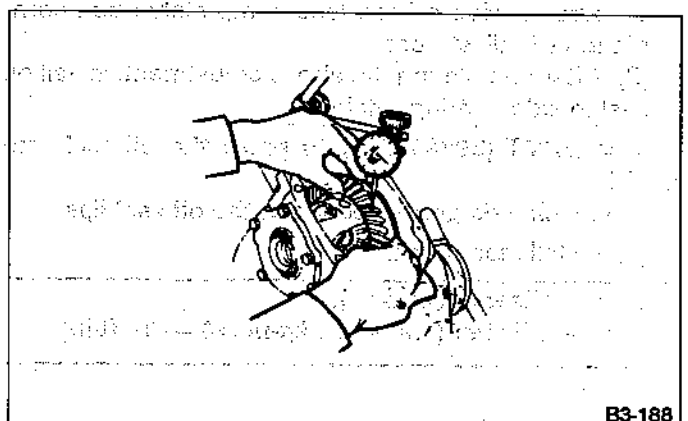


Fig. 67

(7) At the same time, measure the turning resistance of drive pinion. Compared with the resistance when differential case is not installed, if the increase of the resistance is not within the specified range, readjust side bearing retainer shims.

Turning resistance increase:

0.1 — 0.6 N·m (1 — 6 kg-cm, 0.9 — 5.2 in-lb)

(8) Recheck drive gear-to-pinion backlash after readjusting shims.

(9) Check the drive gear runout on its back surface, and make sure pinion and drive gear rotate smoothly.

Limit of runout:

0.05 mm (0.0020 in)

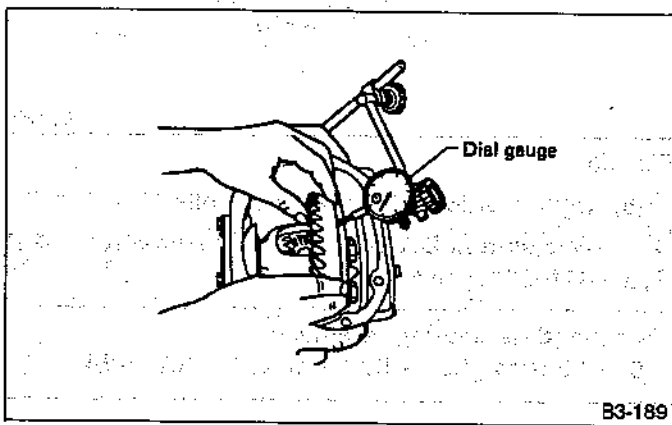


Fig. 68

15) Checking and adjusting tooth contact of drive gear.

(1) Paint evenly both sides of three or four teeth on drive gear with red lead. Check the contact pattern after rotating drive gear several revolutions back and forth until definite contact pattern develops on drive gear.

(2) When the contact pattern is incorrect, readjust according to the instructions given in "Tooth contact pattern".

Be sure to wipe off red lead completely upon completion of adjustment.

(3) After completing the above adjustment, install oil seal in side bearing retainer.

a. Use DRIFT (398437700) to press the oil seal into position.

b. Apply chassis grease between the oil seal lips.

(4) Install rear cover.

Torque (Rear cover bolt):

19 — 25 N·m (1.9 — 2.6 kg-m, 14 — 19 ft-lb)

16) Assemble spindle into differential and tighten bolt with WRENCH. (Non-LSD model)

Special tool:

WRENCH (925560000)

17) After assembling circlip on spindle, set spindle into differential and install by hitting it with a plastic hammer. (LSD model)

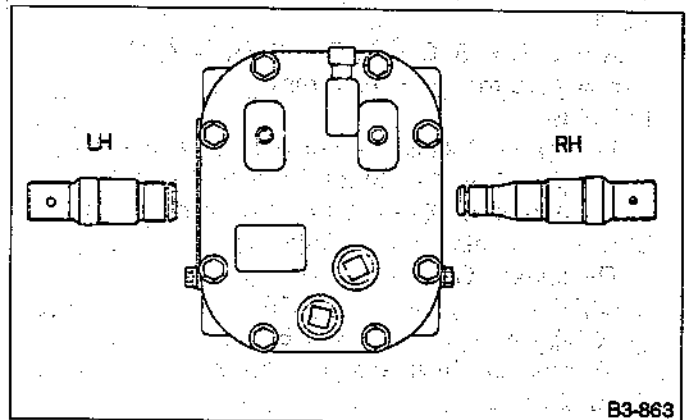


Fig. 69

G: MOUNTING

1) While raising rear differential with a transmission jack, insert rear drive shaft DOJ into differential spindle. Tighten four self-locking nuts at the front and two self-locking nuts at the rear.

2) Position front member on body by passing it under parking brake cable, and secure to rear differential.

3) Install other parts in the reverse order of dismounting.

4) After installation fill differential carrier with gear oil to the upper plug level.

Apply fluid packing to plug.

Fluid packing:

Three-bound 1205 or equivalent

Oil capacity:

0.8 l (0.8 US qt, 0.7 Imp qt)

TOOTH CONTACT PATTERN




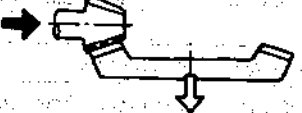
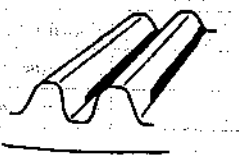
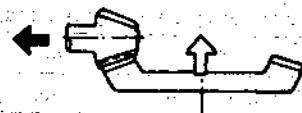




Condition	Contact pattern	Adjustment
<p>Correct tooth contact.</p> <p>Tooth contact pattern slightly shifted towards toe under no load rotation. (When loaded, contact pattern moves toward heel.)</p>		
<p>Face contact</p> <p>Backlash is too large.</p>		 <p>Increase thickness of drive pinion height adjusting washer in order to bring drive pinion closer to drive gear center.</p>
<p>Flank contact</p> <p>Backlash is too small.</p>		 <p>Reduce thickness of drive pinion height adjusting washer in order to move drive pinion away from drive gear.</p>
<p>Toe contact</p>		 <p>Contact area is small. This may cause chipping at toe ends.</p> <p>Adjust as for flank contact.</p>
<p>Heel contact</p>		 <p>Contact area is small. This may cause chipping at heel ends.</p> <p>Adjust as for face contact.</p>

Fig. 70

T TROUBLESHOOTING

1. Rear Differential

Symptom and possible cause	Remedy
Oil leakage	
<ul style="list-style-type: none"> Worn, scratched, or incorrectly seated front or side oil seal. Scored, battered, or excessively worn sliding surface of companion flange. 	Repair or replace.
<ul style="list-style-type: none"> Clogged or damaged air breather. 	Clean, repair or replace.
<ul style="list-style-type: none"> Loose bolts on differential spindle or side retainer, or incorrectly fitted O-ring. 	Tighten bolts to specified torque. Replace O-ring.
<ul style="list-style-type: none"> Loose rear cover attaching bolts or damaged gasket. 	Tighten bolts to specified torque. Replace gasket and apply liquid packing.
<ul style="list-style-type: none"> Loose oil filler or drain plug. 	Retighten and apply liquid packing.
<ul style="list-style-type: none"> Wear, damage or incorrectly fitting for spindle, side retainer and oil seal. 	Repair or replace.
Seizure Seized or damaged parts should be replaced, and also other parts should be thoroughly checked for any defect and should be repaired or replaced as required.	
<ul style="list-style-type: none"> Insufficient backlash for hypoid gear. 	Readjust or replace.
<ul style="list-style-type: none"> Excessive preload for side, rear, or front bearing. 	Readjust or replace.
<ul style="list-style-type: none"> Insufficient or improper oil used. 	Replace seized part and fill with specified oil to specified level.
Damage Damaged parts should be replaced, and also other parts should be thoroughly checked for any defect and should be repaired or replaced as required.	
<ul style="list-style-type: none"> Improper backlash for hypoid gear. 	Replace.
<ul style="list-style-type: none"> Insufficient or excessive preload for side, rear, or front bearing. 	Readjust or replace.
<ul style="list-style-type: none"> Excessive backlash for differential gear. 	Replace gear or thrust washer.
<ul style="list-style-type: none"> Loose bolts and nuts such as drive gear bolt. 	Retighten.
<ul style="list-style-type: none"> Damage due to overloading. 	Replace.
Noises when starting or shifting gears Noises may be caused by differential ASSY, universal joint, wheel bearing, etc. Find out what is actually making noise before disassembly.	
<ul style="list-style-type: none"> Excessive backlash for hypoid gear. 	Readjust.
<ul style="list-style-type: none"> Excessive backlash for differential gear. 	Replace gear or thrust washer.
<ul style="list-style-type: none"> Insufficient preload for front or rear bearing. 	Readjust.
<ul style="list-style-type: none"> Loose drive pinion nut. 	Tighten to specified torque.
<ul style="list-style-type: none"> Loose bolts and nuts such as side bearing retainer attaching bolt. 	Tighten to specified torque.

Trouble and possible cause	Remedy
Noises	
• Damaged thrust washer.	Replace.
• Excessive wear of thrust washer.	Replace.
• Broken gear teeth.	Replace.
• Seized or damaged side bearing.	Replace.
Gear noises	
Since exhaust, engine, muffler, transmission, propeller shaft, wheel bearings, tires, and body are sometimes mistaken for noises from differential ABS , be careful in checking them. Inspection methods to locate noises include coasting, accelerating, cruising, and jacking up all four wheels. Perform these inspections according to condition of trouble. When listening to noises, shift gears into four wheel drive and fourth gear position, trying to pick up only differential noise.	
• Improper tooth contact of hypoid gear.	Readjust or replace hypoid gear set.
• Improper backlash for hypoid gear.	Readjust.
• Scored or chipped teeth of hypoid gear.	Replace hypoid gear set.
• Seized hypoid gear.	Replace hypoid gear set.
• Improper preload for front or rear bearings.	Readjust.
• Seized, scored, or chipped front or rear bearing.	Replace.
• Seized, scored, or chipped side bearing.	Replace.
• Vibrating differential carrier.	Replace.

2. Propeller Shaft

Trouble and possible cause	Remedy
Vibration of propeller shaft	
Vibration is caused by propeller shaft during operation and is transferred to vehicle body. Generally vibration increase in proportion to vehicle speed.	
• Worn or damaged universal joint.	Replace.
• Unbalanced propeller shaft due to bend or dent.	Replace.
• Loose installation of propeller shaft.	Retighten.
• Worn or damaged center bearing and damaged center mounting rubber.	Replace.
Tapping when starting and noise while cruising, caused by propeller shaft.	
• Worn or damaged universal joint.	Replace.
• Worn spline of sleeve yoke.	Replace.
• Loose installation of propeller shaft.	Retighten.
• Loose installation of joint.	Replace.
• Worn or damaged center bearing and damaged center mounting rubber.	Replace.

Vibration while cruising may be caused by an unbalanced tire, improper tire inflation pressure, improper wheel alignment, etc.

